

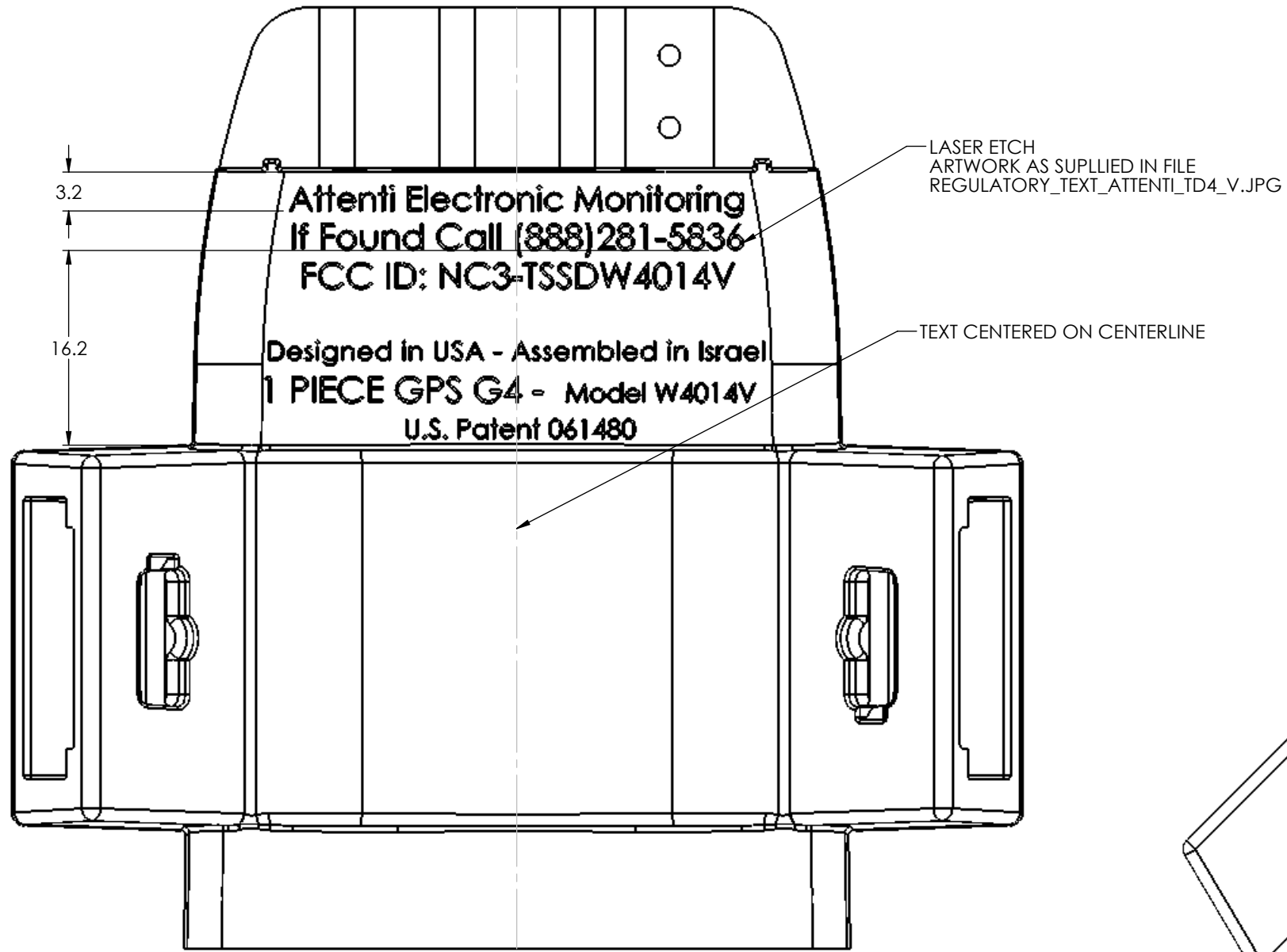

REVISIONS					
ECO	REV.	DESCRIPTION	DATE	BY	APRV
007559	A00	INITIAL RELEASE	1/16/18	GK	NM

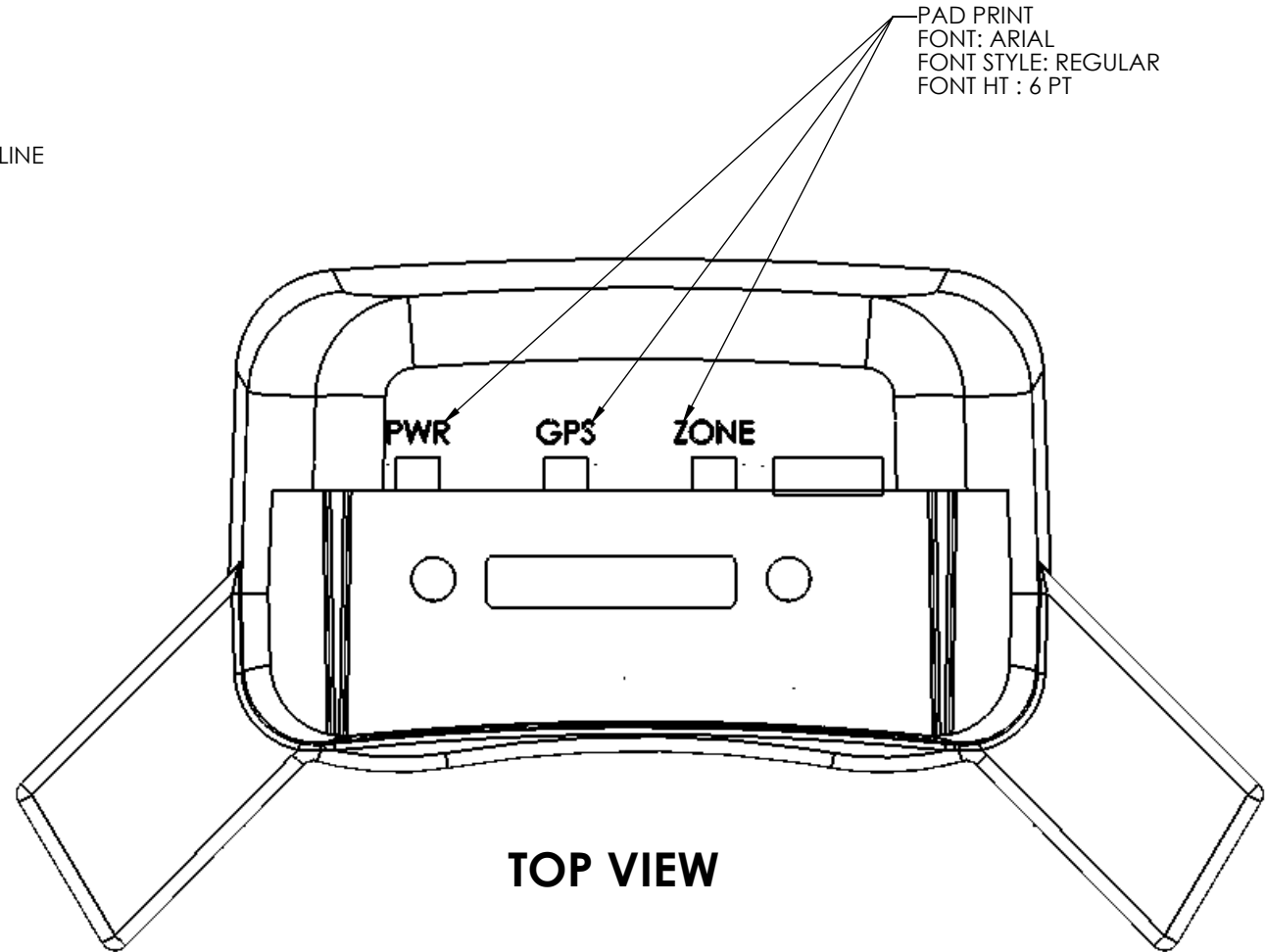

REAR/BACK VIEW



TOP VIEW

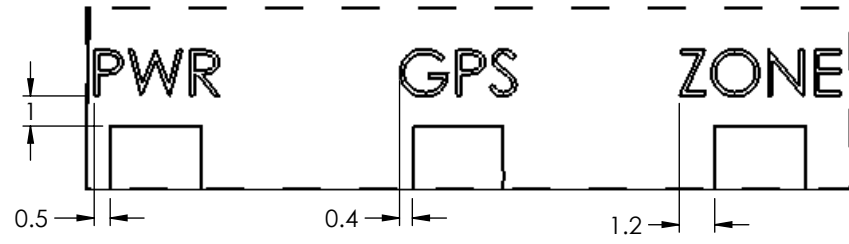

PAD PRINT LOCATIONS

NOTES:

1. LASER ETCH AND PAD PRINTING AS SHOWN ONTO ATTENTI PART NUMBER 32000355.
2. PACKAGING REQUIREMENTS: INDIVIDUALLY BAGGED, DESICCANT IN BOX
3. EACH PART SHALL BE CLEAN, FREE OF OILS AND/OR DEBRIS, AND PACKED IN INDIVIDUAL BAG. SHIPPING BOX SHALL BE MARKED WITH ATTENTI PART NUMBER, REVISION, RAW MATERIAL LOT NUMBER, MANUFACTURE LOT NUMBER, AND DATE OF MANUFACTURE

DIMENSIONS ARE IN MILLIMETERS		NAME	DATE (MM-DD-YY)	
TOLERANCES (UNLESS OTHERWISE SPECIFIED)		DRAWN	G KLETER 01-12-18	
0.5 TO 6 ± 0.1		CHECKED	N MILFI 01-16-18	TITLE: PLASTIC MAIN HOUSING W/ PRINTING FOR 1PIECE G4 CDMA
> 6 TO 30 ± 0.2		PROJECTION: 		
> 30 TO 120 ± 0.3		SYMBOL KEY:		PART. NO. 32000355
> 120 TO 400 ± 0.5		△ REVISION		SIZE DOC. NO.
ANGULAR: ± .5°		○ INSPECTION DIMENSION		B 32480180
MATERIAL	SABIC CYCOLOY C2800 100% VIRGIN	○ ITEM NUMBER (PARTS LIST)		REV
FINISH	MT11000	○ CORRESPONDING NOTE		A00
THIS DOCUMENT IS COPYRIGHTED PROPERTY OF THE ATTENTI COMPANY AND MAY NOT BE REPRODUCED WITHOUT WRITTEN PERMISSION OR USED OR DISCLOSED FOR OTHER THAN AUTHORIZED PURPOSES.		WEIGHT (gr): 40.7		SHEET 1 OF 1
INTERPRET PER ASME Y14.5M-1994				