

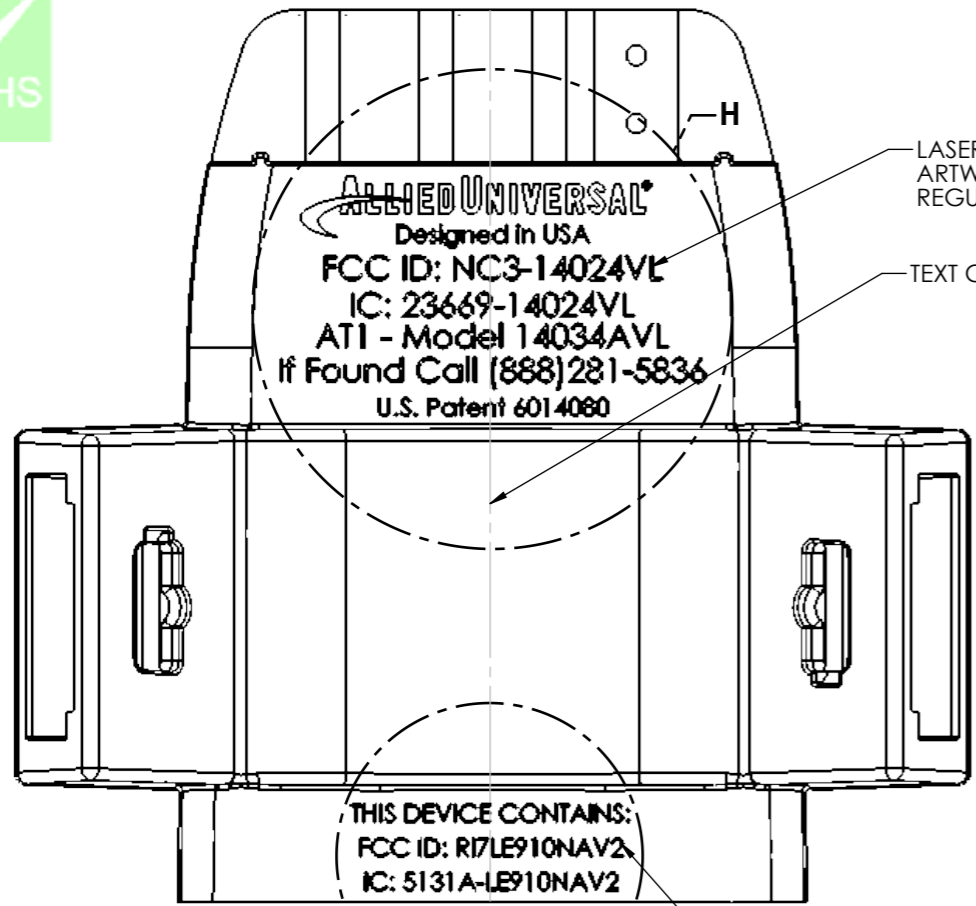

REVISIONS					
ECO	REV.	DESCRIPTION	DATE	BY	APRV
010049	A00	Released for production	04/20/2023	Taras	Ravid

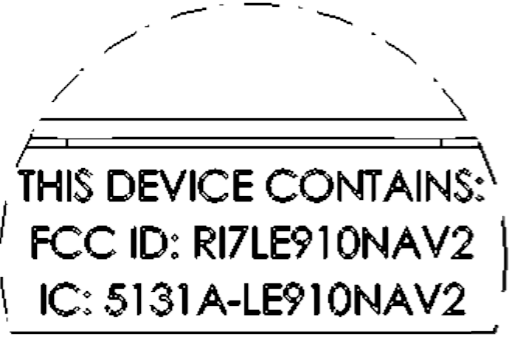

REAR/BACK VIEW



DETAIL G
SCALE 2.5:1

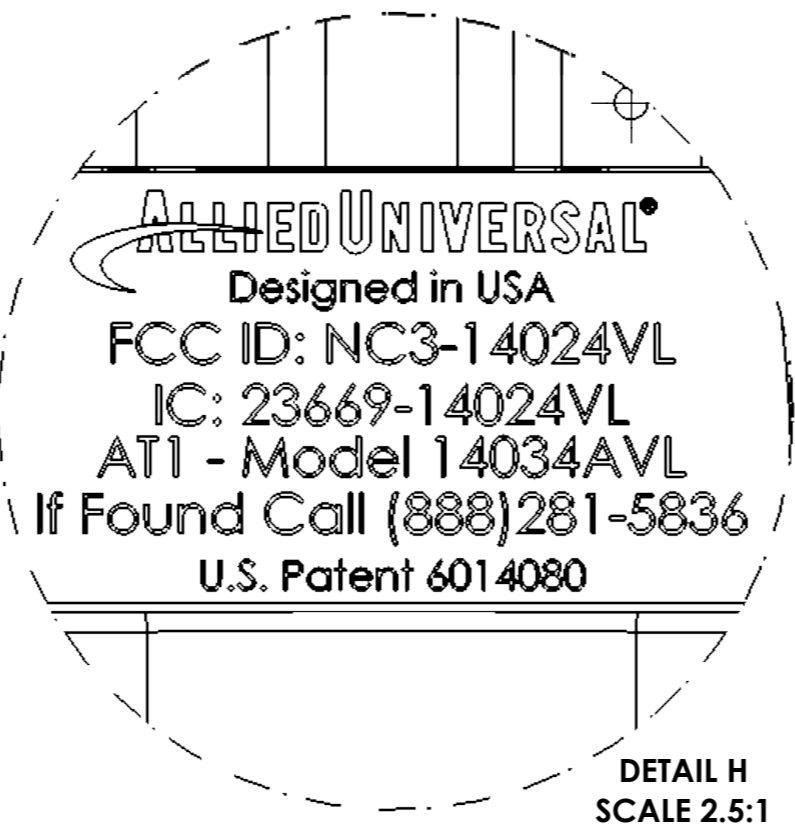

DETAIL H
SCALE 2.5:1

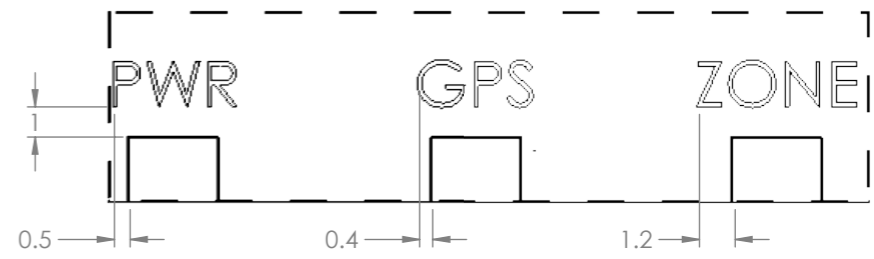

PAD PRINT LOCATIONS

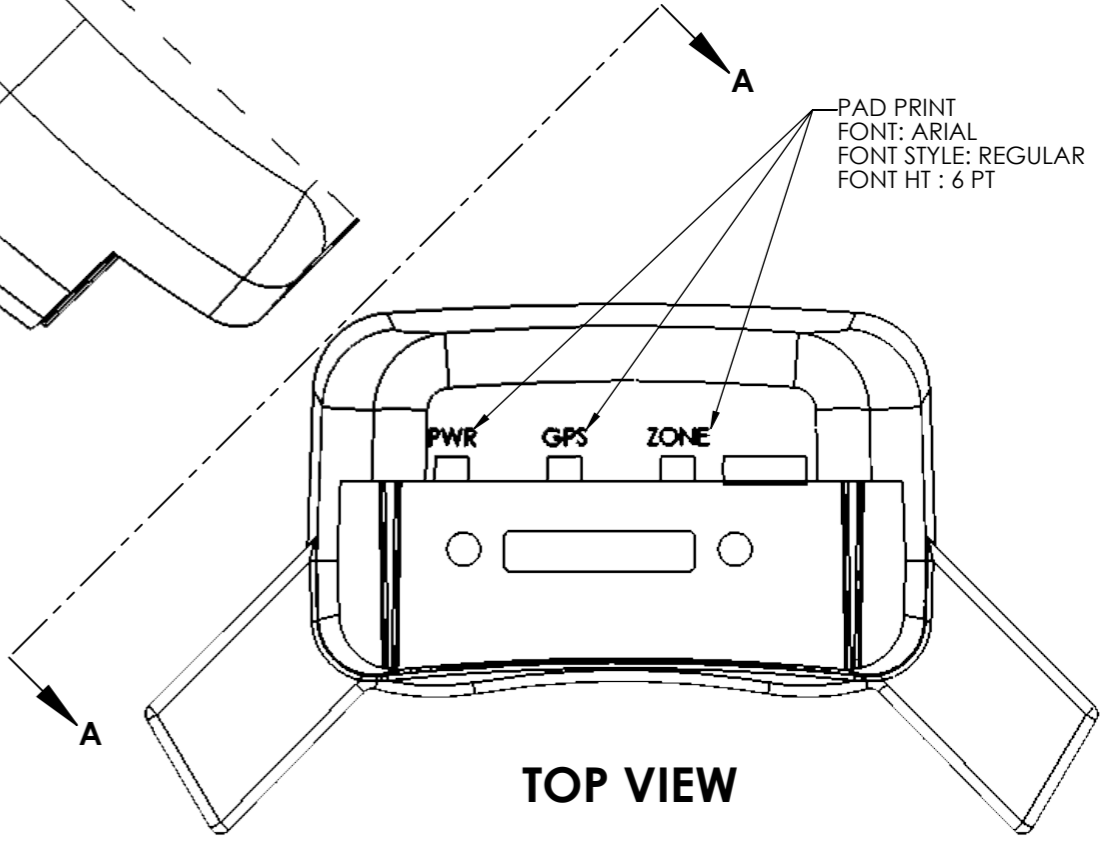

TOP VIEW

- NOTES:
- LASER ETCH AND PAD PRINTING AS SHOWN ONTO PART NUMBER 32000355.
 - PACKAGING REQUIREMENTS: INDIVIDUALLY BAGGED, DESICCANT IN BOX
 - EACH PART SHALL BE CLEAN, FREE OF OILS AND/OR DEBRIS, AND PACKED IN INDIVIDUAL BAG SHIPPING BOX SHALL BE MARKED WITH PART NUMBER, REVISION, RAWMATERIAL LOT NUMBER, MANUFACTURE LOT NUMBER, AND DATE OF MANUFACTURE
 - LARGE TEXT TAHOMA HEIGHT = 5.6 MM
 - SMALL TEXT TAHOMA HEIGHT = 4.3 MM

DIMENSIONS ARE IN MILLIMETERS		NAME	DATE	
TOLERANCES (UNLESS OTHERWISE SPECIFIED)		DRAWN	TarasK 12/03/2023	
0.5 TO 6	± 0.1	CHECKED	RavidMY 12/03/2023	
> 6 TO 30	± 0.2	PROJECTION: 		
> 30 TO 120	± 0.3	SYMBOL KEY: △ REVISION ○ INSPECTION DIMENSION ○ ITEM NUMBER (PARTS LIST) ○ CORRESPONDING NOTE		
> 120 TO 400	± 0.5	INPERPRET PER ASME Y14.5M-1994		
ANGULAR:	± .5°			
MATERIAL	N/A	TITLE: PLASTIC MAIN HOUSING W/ PRINTING FOR 1 PIECE AT1 LTE AT AUS		
FINISH	SEE NOTES	PART. NO. 32001029 SCALE 1.5:1		
THIS DOCUMENT IS COPYRIGHTED PROPERTY OF ALLIED UNIVERSAL ELECTRONIC MONITORING COMPANY AND MAY NOT BE REPRODUCED WITHOUT WRITTEN PERMISSION OR USED OR DISCLOSED FOR OTHER THAN THE COMPANY AUTHORIZED PURPOSES.		SIZE	DOC. NO.	REV
		A3	32001029	A00
		WEIGHT (gr): 40.7		SHEET 1 OF 1