

## Exhibit 2

### Minstrel - 540

**Novatel Wireless Technologies Ltd.**

**FCC ID: NBZRNM6833**

**Engineering Reports**  
(With Test Set-up Photographs)

**Effective Radiated Power  
Spurious Radiation**



# Assessment of Compliance

for

Measurement of Effective Radiated Power (ERP) in  
accordance with the FCC Rules & Regulations Part 2.1046

## Wireless CDPD Modem Minstrel 540

Novatel Wireless Technologies Ltd.

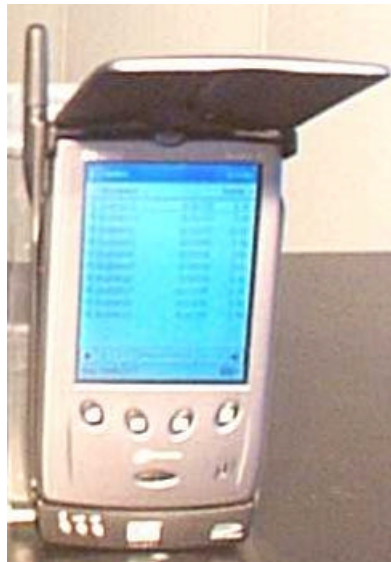

August 2000

NVWB-MINSTREL 540 -3539

51 Spectrum Way Nepean ON K2R 1E6  
Tel: (613) 820-2730 Fax: (613) 820-4161  
email: [info@aprel.com](mailto:info@aprel.com)

## Engineering Report

**Subject:** Measurement of Effective Radiated Power (ERP) in accordance with the FCC Rules & Regulations Part 2.1046

**Equipment:** Wireless CDPD Modem

**Model:** Minstrel 540

**Client:** Novatel Wireless Technologies Ltd.,  
Suite 200  
6715-8<sup>th</sup> Street, N.E.  
Calgary, Alberta  
Canada, T2E 7H7

**Project #:** NVWB-MINSTREL 540-3539

**Prepared By:** APREL Laboratories,  
Regulatory Compliance Division

Approved by:

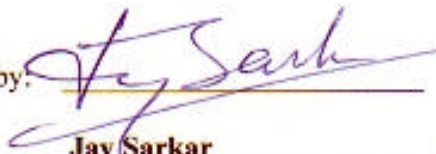

**Jay Sarkar**  
Director, Standards & Certification

Date:

Aug. 18, 2000

Released by:



**Dr. Jack J. Wojcik, P.Eng.**



**FCC ID:** NBZNRM6833  
**Applicant:** Novatel Wireless Technologies Ltd.  
**Equipment:** Wireless CDPD Modem  
**Model:** Minstrel 540  
**Standard:** FCC Rules and Regulations Part 2.1046

### **ENGINEERING SUMMARY**

This report contains the results of the effective radiated power (ERP) measurement performed on a NOVATEL WIRELESS Minstrel 540 wireless CDPD modem. The measurements were carried out in accordance with the FCC Rules and Regulations Part 2.1046. The product was evaluated for ERP when it was set at the maximum power level.

The Minstrel 540 wireless CDPD modem is an attachment for the HP Jornada 540 Series Pocket PC..

Minstrel 540 was tested for ERP at high, middle, and low frequencies with the maximum ERP obtained at channel No.: 991 with the frequency being 824.04 MHz. The test data is presented in this report under the section: Test Results. The measured ERP is 0.316 W.

(The results presented in this report relate only to the sample tested)

## Summary of the Results

Test Description	Page No.	Test Set-up Figure No.	Results Summary
RF Power Output as Radiated Ref. Paragraph 2.1046	8	1	<b>Passed</b>

## INTRODUCTION

### General

This report describes the results of the effective radiated power (ERP) measurement conducted on a Novatel Wireless Minstrel 540 wireless CDPD modem herein referred to as DUI (Device under Investigation)

### Test Facility

The tests were performed for Novatel by APREL Laboratories at APREL's EMI facility located in Nepean, Ontario, Canada. The laboratory operates an (3m and 10m) Open Area Test Site (OATS). The measurement facility is calibrated in accordance with ANSI C63.4-1992.

A description of the measurement facility in accordance with the radiated and AC line conducted test site criteria per ANSI C63.4-1992 is on file with the Federal Communications Commission and is in compliance with the requirements of Section 2.948 of the Commissions rules and regulations.

***APREL's registration number is: 90416***

APREL is accredited by Standard Council of Canada, under PALCAN program (ISO Guide 25). APREL is also accredited by Industry Canada (formerly DOC) and recognised by the Federal Communications Commissions (FCC).

### Standard

The evaluation and analysis were conducted in accordance with FCC Rules and Regulations Parts 2.1046 and the appropriate limits.

### Test Equipment

The test equipment used during the evaluation is listed in Appendix A with calibration due dates.

### Environmental Conditions

Measurements were conducted in open area test site.

- Temperature: 15 °C ± 2
- Relative Humidity: 30 - 50 %

- Air Pressure: 101 kPa  $\pm$  3

## FCC SUBMISSION INFORMATION

**FCC ID:** NBZNRM6833

**Equipment:** Wireless CDPD Modem

**Model:** Minstrel 540

**For:** Certification

**Applicant:** Novatel Wireless Technologies Ltd.  
Suite 200  
6715-8<sup>th</sup> Street, N.E.  
Calgary, Alberta  
Canada, T2E 7H7

**Manufacturer:** Novatel Wireless Technologies Ltd.  
Suite 200  
6715-8<sup>th</sup> Street, N.E.  
Calgary, Alberta  
Canada, T2E 7H7

**Evaluated by:** APREL Laboratories  
51 Spectrum Way  
Nepean, Ontario  
Canada K2R 1E6

## MANUFACTURER'S DATA

<b>FCC ID No:</b>	NBZNRM6833
<b>Equipment Type:</b>	Wireless CDPD Modem
<b>Model:</b>	Minstrel 540
<b>Reference:</b>	FCC Rules and Regulations Parts 2 and Part 22
<b>Manufacturer:</b>	Novatel Wireless Technologies Ltd.
<b>Power Source:</b>	DC Battery
<b>Development Stage of Unit:</b>	Production

## GENERAL SPECIFICATIONS

1. Frequency Range: 824 to 849 MHz (Transmitter)
2. Output Power: 0.316 W ERP
3. Frequency Tolerance: 2.5 ppm
4. Type of Modulation: GMSK
5. Emission Designators(See 47 CFR § 2.201 and §2.202) 28K8FXW
6. Antenna Impedance: 50 Ohms



**TEST RESULTS**

**FOR**

**Effective Radiated Power (ERP)**

**Of**

**Novatel Wireless Minstrel 540 CDPD**

**modem**

***Novatel Wireless***

**Test:** RF Power Output as Radiated (ERP)

**Ref.:** FCC Part 2 paragraph 2.1046

**Criteria:** N/A

**Set-up:** See Figure No. 1.

**Equipment:** See Appendix A.

**Methodology:** RF Power Measurement by Radiated Method (ERP):

Test site: The radiated RF power measurement was taken at APREL Laboratory's open area test site (OATS). This open area test site is calibrated to ANSI C63.4 document and a description of the measurement facility is on file with the Federal Communications Commission and is in compliance with the requirement of Section 2.948 of the Commissions rules and regulations. (FCC File No.: 90416)

The test was set-up as illustrated in Fig.1. The Minstrel 540 was configured to operate at maximum power with carrier **unmodulated**. The equipment under test was placed on a turntable positioned 3 m away from the calibrated receiving antenna, which in turn was connected to the spectrum analyzer.

For each transmitter frequency, the received signal was **maximised** by rotating the turntable and adjusting the height of the receiving antenna. To obtain the actual ERP, the Minstrel 540 was replaced by a vertically polarised half-wave dipole antenna resonant to that frequency and fed by a RF power amplifier and signal generator. The center of the dipole antenna was placed precisely in the same location as the Minstrel 540. It was ensured that the orientation of the rotating table and the height of the receiving antenna were unmoved. The signal generator level was adjusted until the peak reading on the spectrum analyzer was identical to that obtained when the Minstrel 540 was on the turntable. The two signals were matched by superimposing one signal to the other on the spectrum analyzer screen. The output of power amplifier was disconnected from the substitute dipole antenna and connected to a RF power meter. **The effective radiated power was read directly form the power meter.**

**The process was repeated for two more channels.**

**Results:** See Table 1

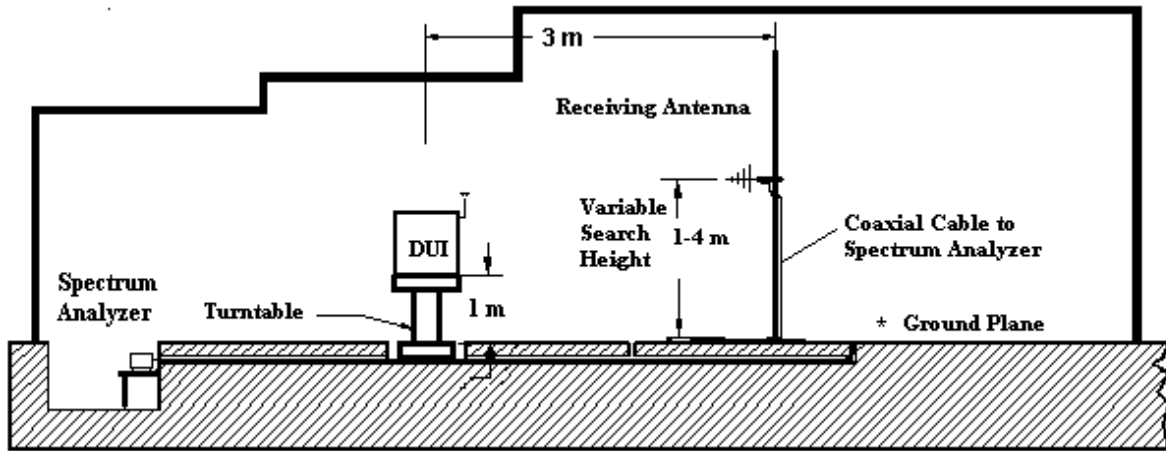

Figure 1.a Test set up for the Radiated Power (ERP) Measurement in OATS (not to scale)



Fig. 1.b APREL's OATS (Open Area Test Site)

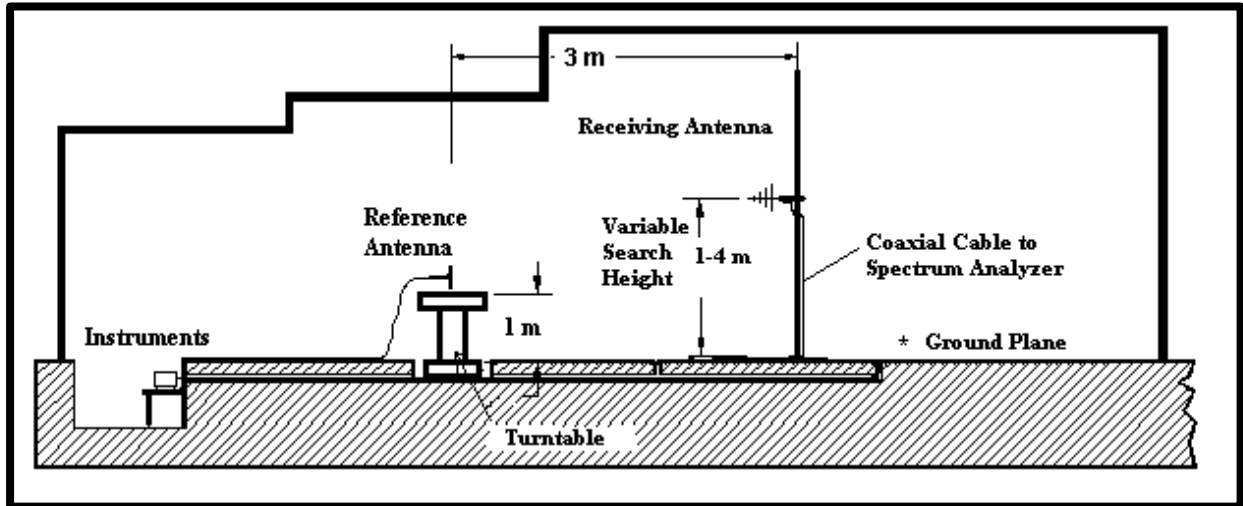

Figure 1.c Test set up for the Radiated Power (ERP) Measurement in OATS (not to scale)  
The DUI is replaced by Reference Dipole Antenna.

**Table 1.**  
**RF Output Power Measurement**  
**ERP**  
**Minstrel 540**

Channel No.	Nominal Transmit Frequency	Measured Output Power ERP	ERP
	(MHz)	(dBm)	(W)
991	824.04	25.0	0.316
367	836.01	24.6	0.288
799	848.97	23.7	0.234

Test Engineer..... *Ku Celia Polina* Date..... *Aug 17, 2000*

# APPENDIX A

## List of Test Equipment

**List of Equipment used**

<b>Description</b>	<b>Manufacturer</b>	<b>Model #</b>	<b>Asset #</b>	<b>Calibration Due Data</b>
Spectrum Analyzer	Anritsu	MS2661C	301330	Dec 10, 2000
Power Meter	Rhode & Schwarz	NRVS	00851	July 21, 2001
20 dB Attenuator	Narda	4779-20	301370	May 18, 2001
Signal Generator	Hewlett-Packard	HP 8662A	100456	Nov 1, 2000
RF Power Amplifier	Amplifier Research	25W100M	100735	Sep 16, 2000
Reference Half wave Dipole	APREL Inc.	D-8355	N/A	June 16, 2001
Log Periodic Antenna	Eaton	ALP-1	100553	July 21, 2001
Turntable with Controller	EMCO	1060-1.241	100506	CNR
Computer Controlled Antenna Position Mast	EMCO	1051-12	100507	CNR
OATS	APREL Inc.	3m & 10m	N/A	N/A

# APPENDIX B

## PHOTOGRAPHS





**Novatel Wireless  
Minstrel 540**

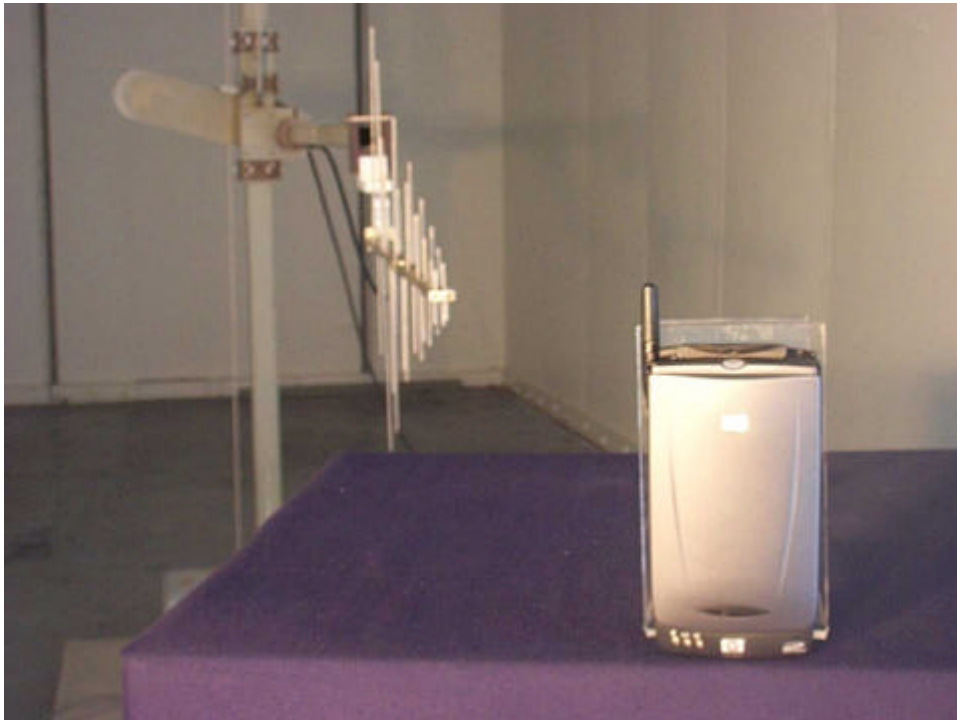

### **ERP Measurements in OATS**



**Reference Dipole Antenna Used for ERP Measurement**



# Assessment of Compliance

for

Measurement of Field Strength of Spurious  
Radiation in Accordance with the  
FCC Rules & Regulations Part 2.1053

**Wireless CDPD Modem  
Minstrel 540**

Novatel Wireless Technologies Ltd.

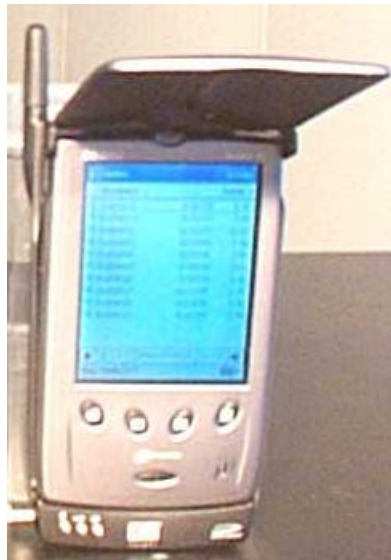

August 2000

NVWB-MINSTREL 540 -3540

51 Spectrum Way Nepean ON K2R 1E6  
Tel: (613) 820-2730 Fax: (613) 820-4161  
email: [info@aprel.com](mailto:info@aprel.com)

## Engineering Report

**Subject:** Measurement of: Field Strength of Spurious Radiation in Accordance with the FCC Rules & Regulations Part 2.1053

**Equipment:** Wireless CDPD Modem

**Model:** Minstrel 540

**Client:** Novatel Wireless Technologies Ltd.,  
Suite 200  
6715-8<sup>th</sup> Street, N.E.  
Calgary, Alberta  
Canada, T2E 7H7

**Project #:** NVWB-MINSTREL 540-3540

**Prepared By:** APREL Laboratories,  
Regulatory Compliance Division

**Approved by:**



**Date:**

Aug. 18, 2000

**Jay Sarkar**  
Director, Standards & Certification

**Released by:**



**Dr. Jack J. Wojcik, P.Eng.**



**FCC ID:** NBZNRM6833  
**Applicant:** Novatel Wireless Technologies Ltd.  
**Equipment:** Wireless CDPD Modem  
**Model:** Minstrel 540  
**Standard:** FCC Rules and Regulations Part 2.1046

### **ENGINEERING SUMMARY**

This report contains the results of Field Strength of Spurious Radiation measurement performed on a Novatel Wireless Minstrel 540 wireless CDPD modem. The measurements were carried out in accordance with the FCC Rules and Regulations Part 2.1053. The product was evaluated for spurious when it was set at the maximum power level.

The Minstrel 540 wireless CDPD modem is an attachment for the HP Jornada 540 Series Pocket PC.

(The results presented in this report relate only to the sample tested)

### Summary of the Results

Test Description	Page No.	Test Set-up Figure No.	Results Summary
Field Strength of Spurious Radiation Ref. Paragraph 2.1053	8	1	<b>Passed</b>

## INTRODUCTION

### General

This report describes the results of the Field Strength of Spurious Radiation measurement conducted on a Novatel Wireless Minstrel 540 CDPD modem herein referred to as DUI (Device Under Investigation).

### Test Facility

The tests were performed for Novatel Wireless by APREL Laboratories at APREL's EMI facility located in Nepean, Ontario, Canada. The laboratory operates an (3m and 10m) Open Area Test Site (OATS). The measurement facility is calibrated in accordance with ANSI C63.4-1992.

A description of the measurement facility in accordance with the radiated and AC line conducted test site criteria per ANSI C63.4-1992 is on file with the Federal Communications Commission and is in compliance with the requirements of Section 2.948 of the Commissions rules and regulations.

***APREL's registration number is 90416***

APREL is accredited by Standard Council of Canada, under PALCAN program (ISO Guide 25). APREL is also accredited by Industry Canada (formerly DOC) and recognised by the Federal Communications Commissions (FCC).

### Standard

The evaluation and analysis were conducted in accordance with FCC Rules and Regulations Parts 2.1053 and the appropriate limits.

### Test Equipment

The test equipment used during the evaluation is listed in Appendix A with calibration due dates.

### Environmental Conditions

Measurements were conducted in open area test site.

- Temperature: 20 °C ± 2
- Relative Humidity: 30 - 50 %
- Air Pressure: 101 kPa ± 3



## FCC SUBMISSION INFORMATION

**FCC ID:** NBZNRM6833

**Equipment:** Wireless CDPD Modem

**Model:** Minstrel 540

**For:** Certification

**Applicant:** Novatel Wireless Technologies Ltd.  
Suite 200  
6715-8<sup>th</sup> Street, N.E.  
Calgary, Alberta  
Canada, T2E 7H7

**Manufacturer:** Novatel Wireless Technologies Ltd.  
Suite 200  
6715-8<sup>th</sup> Street, N.E.  
Calgary, Alberta  
Canada, T2E 7H7

**Evaluated by:** APREL Laboratories  
51 Spectrum Way  
Nepean, Ontario  
Canada K2R 1E6

## MANUFACTURER'S DATA

**FCC ID No:** NBZNRM6833

**Equipment Type:** Wireless CDPD Modem

**Model:** Minstrel 540

**Reference:** FCC Rules and Regulations Parts 2 and Part 22

**Manufacturer:** Novatel Wireless Technologies Ltd.

**Power Source:** DC Battery

**Development Stage of Unit:** Production

## GENERAL SPECIFICATIONS

1. Frequency Range: 824 to 849 MHz (Transmitter)
2. Output Power: 0.316 W ERP
3. Frequency Tolerance: 2.5 ppm
4. Type of Modulation: GMSK
5. Emission Designators(See 47 CFR § 2.201 and §2.202) 28K8FXW
6. Antenna Impedance: 50 Ohms

**TEST RESULTS**

**FOR**

**Field Strength of Spurious Radiation  
Of  
Novatel Wireless Minstrel 540 CDPD  
Modem**

***Novatel Wireless.***

**Test:** Field Strength of Spurious Radiation

**Ref:** FCC Parts 2.1046 and 22.917 (e)

**Criteria:** Emission :  
The permitted maximum level of spurious emission is  $43 + 10 \log (P)$  dB below the unmodulated carrier power of the transmitter (P). This was calculated to be 84.6 dB $\mu$ V/m at 3 meters.

**Set-up:** See Figure 1.a

**Conditions:** Voltage Supply: 7.4/8.4 DC Battery

**Equipment:** See Appendix A.

**Procedure:** The final measurements were taken at APREL Laboratory's open area test site (OATS) measurement facility. This open area test site is calibrated to ANSI C63.4 document and a description of the measurement facility is on file with the Federal Communications Commission and is in compliance with the requirements of Section 2.948 of the Commissions rules and regulations. (FCC Registration No.:90416).

The **Minstrel 540** was configured to operate at maximum power with appropriate modulation. Special software was employed in order that the transmitter was processing data in a normal manner.

Prior to final measurement in the OATS, preliminary radiated spurious emissions were scanned in a shielded enclosure at a distance of 1 m using biconical, log-periodic and horn antennas in order to determine the characteristic frequencies of the field strength of spurious emissions. Based on this information, measurements were performed in the OATS at these characteristic frequencies using calibrated antennas.

All field strength measurements were made with a spectrum analyser and the appropriate calibrated antenna for the frequency range from 9 kHz up to 10<sup>th</sup> harmonics of the transmit frequency (see equipment list for the calibrated antenna used). **The Power of the carrier frequency was also measured in the OATS.**

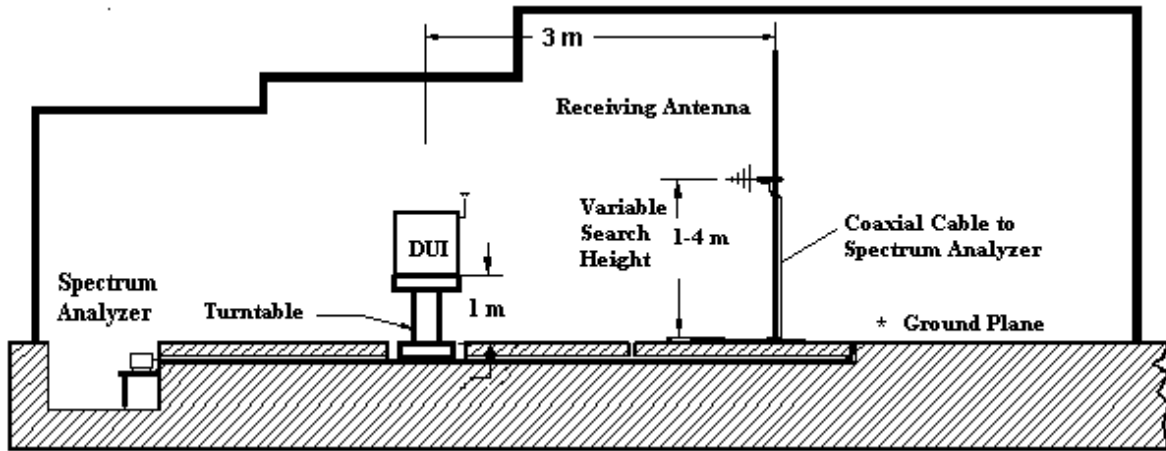

Figure 1.a Test set up for the Field Strength of Spurious Radiation Measurement in OATS  
(Not to scale)



Fig. 1.b APREL's OATS (Open Area Test Site)

The equipment under test was placed on a turntable positioned 3 meters away from the calibrated receiving antenna, which in turn was connected to the spectrum analyzer. For each identified frequency, the received signal was maximized by the positioning of the turntable and the height of the antenna. The process was repeated for both horizontal and vertical polarisation.

Information submitted includes the relative radiated power of each spurious emissions with reference to the calculated 84.6 dBµV/m limit per 22.917(e), assuming all emissions are radiated from half-wave dipole antenna.

Measurements given in the spurious emissions test result tables contain: analyzer reading, correction factor, and final reading. The final field strength level are derived from the analyzer measurement and the correction factor (antenna factor and cable loss) as shown in the following example:

#### Sample Calculation

A. Spectrum analyzer reading

at 1648.08 MHz (2<sup>nd</sup> harmonic) a spurious level of 14.2 dBµV @ 3 meters is measured.

B. Correction factor (antenna factor and cable loss)

Cable loss: 0.5 dB  
 Antenna Factor: 34 dB  
 Total Correction Factor: 0.5 + 34 = 34.5 dB/m

C. Final reading (Field Strength of spurious emission):

$C = A + B$   
 $C = 14.2 \text{ dB}\mu\text{V} + 34.5 \text{ dB}$   
 $C = 48.7 \text{ dB}\mu\text{V/m @ 3 meters}$

D. The criteria level.

The field intensity, which would be produced by the transmitter carrier operating into a half-wave dipole antenna (gain of 1.64), at a distance of 3 m, was calculated using the following formula:

Field Strength of unmodulated carrier (dB $\mu$ V/m) =  $10 \log_{10} (PtG/4\pi r^2) + 146$  dB

Pt is transmitter carrier power, unmodulated

G is gain, 1.64

R is distance, 3 meters

Criteria (reference) level at 3 meters from 0.316 Watt (ERP) into half-wave dipole antenna is 84.6 dB $\mu$ V/m.

E = Margin (spurious emission below the reference level)

$$E = D - C$$

$$E = 84.6 \text{ dB}\mu\text{V/m} - 48.7 \text{ dB}\mu\text{V/m}$$

$$E = 35.9 \text{ dB}\mu\text{V/m}$$

**Results:**      **Passed**      .      **See Tables 1 and 2**



**Table one**  
 Field Strength of Spurious Radiation  
 Transmitter Frequency: 824.04 MHz  
 Antenna Polarization: Vertical  
**Resolution Bandwidth:**  
 10 kHz (below 1 GHz)  
 100 kHz (above 1 GHz)

Frequency (MHz)	Measured Level (dB $\mu$ V)	Correction Factor (dB/m)	Field Strength (dB $\mu$ V/m)	Criteria Level (dB $\mu$ V/m)	Margin (dB)
	"A"	"B"	"C"	"D"	"E"
824.04 1 <sup>st</sup> harmonic (carrier)	93.6	29.9	123.5	-	-
1648.08 2 <sup>nd</sup> harmonic	14.2	34.5	48.7	84.6	35.9
2472.12 3 <sup>rd</sup> harmonic	16.5	35.3	51.8	84.6	32.8
3296.16 4 <sup>th</sup> harmonic	9.5	41.0	50.5	84.6	34.1

Test performed by: Kulcha Pooner

Date: Aug 18, 2000

**Table 2**

Field Strength of Spurious Radiation

Transmitter Frequency: 824.04 MHz

Antenna Polarization: Horizontal

**Resolution Bandwidth:**

10 kHz (below 1 GHz)

100 kHz (above 1 GHz)

Frequency (MHz)	Measured Level (dB $\mu$ V)	Correction Factor (dB/m)	Field Strength (dB $\mu$ V/m)	Criteria Level (dB $\mu$ V/m)	Margin (dB)
	"A"	"B"	"C"	"D"	"E"
824.04 1 <sup>st</sup> harmonic (carrier)	87.6	29.9	117.5	-	-
1648.08 2 <sup>nd</sup> harmonic	17.1	34.5	51.6	84.6	33.0
2472.12 3 <sup>rd</sup> harmonic	5.4	35.3	40.7	84.6	43.9
3296.16 4 <sup>th</sup> harmonic	<3.1	41.0	44.1	84.6	40.5

Test performed by: Kim Alton Pouson

Date: Aug 18, 2000

# APPENDIX A

## List of Test Equipment

### List of Equipment

Description	Range	Manufacturer	Model #	APREL Asset #	Cal. Due Date
Spectrum Analyzer	9 kHz - 3 GHz	Anritsu	MS2661C	301330	Dec 10, 2000
Spectrum Analyzer	9 kHz - 30 GHz	Anritsu	MS2667C	301436	Nov 3, 2000
Biconical Antenna	20 MHz - 200 MHz	Eaton	94455-1	100890	July 21, 2001
Log - Periodic Antenna	200 MHz - 1.0 GHz	Eaton	ALP-1	100761	July 21, 2001
Horn Antenna	1 – 18 GHz	Aprel	AA – 118	100553	March 12, 2001
Anechoic Shielded Room	10 kHz - 10 GHz	APREL Inc.	–	301329	N/A
OATS	30 MHz – 1 GHz	APREL Inc.	3 m & 10 m	N/A	N/A
Mast with the Controller	1 m – 4 m	EMCO	1051 – 12	100507	N/A
Turntable with the Controller	0° - 360°	EMCO	1060 – 1.241	100506	N/A
Notch Filter	820-850 MHz	APREL	NFLT-835	301470	CBT
Attenuator	20 dB	APREL	4779-20	301370	May 18, 2001
Amplifier (LNA)	30-1500 MHz	APREL Inc.	APRLNA-001	301415	June 20, 2001
Microwave Amplifier	2 – 20 GHz	Hewlett-Packard	HP8349B	100952	CBT
Travelling-Wave Tube Amplifier	1.4 – 2.4 GHz	Hughes Aircraft Company	TWTA	100424	CBT

\*CBT stands for Calibrated Before Test

# APPENDIX B

## PHOTOGRAPHS





***Novatel Wireless  
Minstrel 540***

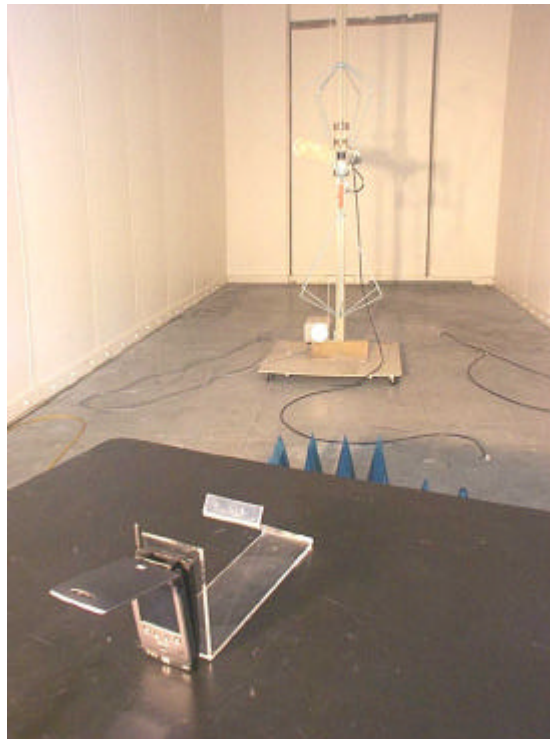

***Spurious Measurements in OATS  
(frequency range: 30 MHz – 200 MHz)***

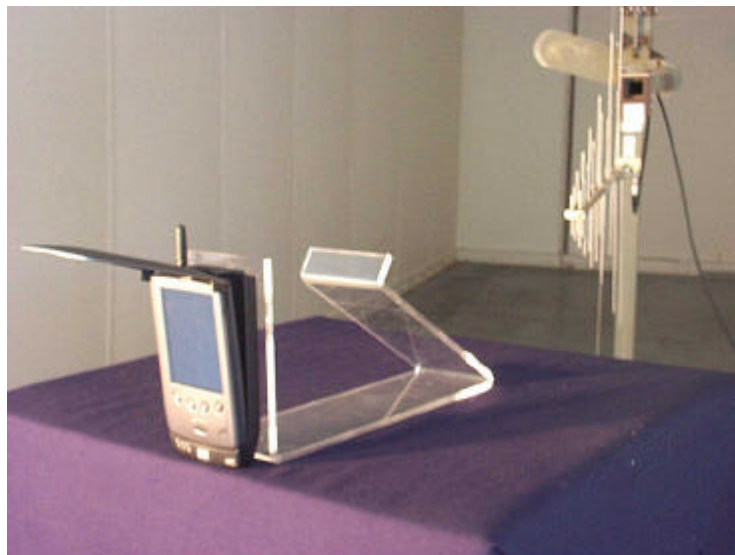

***Spurious Measurements in OATS  
(frequency range: 200 MHz – 1 GHz)***