

Tissue Parameters

850MHz Head liquid:

Recipe:

The following recipe is provided in percentage by weight.

49.46% distilled water
49.46% DGBE
1.0% salt
0.1% bactericide

SAR measurements were made within 24 hours of the measurement of liquid parameters.

Date	Freq. (MHz)	Rel. Perm.	Condy (S/m)
8/9/06	900	41.62	0.985
8/21/06	900	41.36	0.979
9/7/06	900	41.56	0.990
9/11/06	900	41.41	0.982

850MHz Body Liquid:

Recipe:

The following recipe is provided in percentage by weight.

49.8% distilled water
40.6% DGBE
8.9% salt
0.6% HEC
0.1% bactericide

SAR measurements were made within 24 hours of the measurement of liquid parameters.

Date	Freq. (MHz)	Rel. Perm.	Condy (S/m)
8/9/06	824.2	54.79	0.959
8/9/06	836.6	54.6	0.971
8/9/06	848.8	54.51	0.977
8/21/06	824.2	54.86	0.953
8/21/06	836.6	54.69	0.967
8/21/06	848.8	54.6	0.971
9/7/06	824.2	54.92	0.966
9/7/06	836.6	54.71	0.973
9/7/06	848.8	54.60	0.982
9/11/06	824.2	54.85	0.958
9/11/06	836.6	54.69	0.966
9/11/06	848.8	54.54	0.979

1900MHz Head liquid:

Recipe:

The following recipe is provided in percentage by weight.

54.9% distilled water
44.92% DGBE
0.18% salt
0.1% bactericide

SAR measurements were made within 24 hours of the measurement of liquid parameters.

Date	Freq. (MHz)	Rel. Perm.	Condy (S/m)
8/22/06	1900	39.39	1.44
8/25/06	1900	40.16	1.396
9/12/06	1900	40.11	1.412

1900MHz Body Liquid:

Recipe:

The following recipe is provided in percentage by weight.

69.17% distilled water
30.29% DGBE
0.44% salt
0.1% bactericide

SAR measurements were made within 24 hours of the measurement of liquid parameters.

Date	Freq. (MHz)	Rel. Perm.	Condy (S/m)
8/22/06	1850.2	53.21	1.509
8/22/06	1880	52.87	1.544
8/22/06	1909.8	52.51	1.558
8/25/06	1852.4	53.18	1.509
8/25/06	1880	52.82	1.54
8/25/06	1907.6	52.4	1.56
9/12/06	1852.4	53.42	1.551
9/12/06	1880	43.2	1.563
9/12/06	1907.6	53.08	1.559

Environment: 8/9/2006, 8/25/2006 & 9/7/2006 to 9/12/2006

Temperature: 22.0 °C ± 2°C
Humidity: 45% _ 55 %

Test Equipment

Instrument description	Supplier / Manufacturer	Model	Serial No.	Calibration (date)	Calibration Due (date)
Bench top Robot	Mitsubishi supplied by IndexSAR	RV-E2	EA1030108	N/A	N/A
SAM Phantom	Upright shell phantom made by Antenna digitized and mounted by IndexSAR	SAM	03FT26	04/03	N/A
Flat Phantom	IndexSAR	HeadBox_Spout	N/A	N/A	N/A
Software	IndexSAR	SARA2 v2.41 VPM	N/A	N/A	N/A
900 MHz Head Tissue Simulant	Cetecom Inc.	900 Head	N/A	8/9/2006, 8/21/2006, 9/7/2006 & 9/11/2006	N/A
850 MHz Body Tissue Simulant	Cetecom Inc.	850 Body	N/A	8/9/2006, 8/21/2006, 9/7/2006 & 9/11/2006	N/A
1900 MHz Head Tissue Simulant	Cetecom Inc.	1900 Head	N/A	8/22/2006, 8/25/2006 & 9/12/2006	N/A
1900 MHz Body Tissue Simulant	Cetecom Inc.	1900 Body	N/A	8/22/2006, 8/25/2006 & 9/12/2006	N/A
900 MHz Dipole	IndexSAR – IEEE 1528 design	IXD-900	0016	07/20/2006	07/20/2007
1900 MHz Dipole	IndexSAR – IEEE 1528 design	IXD-190	0016	07/20/2006	07/20/2007
Directional coupler	Werlatone	C6529	11249	N/A	N/A
RF Amplifier	Vectawave	VTL5400	N/A	N/A	N/A
SAR Probe	IndexSAR	IXP-030	S/N M0016	9/29/2005	9/29/2006
Dielectric Measurement Kit	IndexSAR	Di-Line	N/A	N/A	N/A

SAR Test Report No:

SAR_NOVAT_010_06002_FCC_850_1900_rev1

Date of Report: 8/28/2006 **Appendix C Calibration Info**

Page 4 of 31

Equipment Calibration/Performance Documents:

Validation Dipoles Performance Measurements:

Pages 5 to 11

SAR Probe Calibration

Pages 12 to 31

Please Note:

(The following pages of Appendix C show calibration documents. These calibration documents are inserted into this appendix. The header information with page numbering scheme is a part of this report and is included on all pages of the report and appendixes. This header is used to track all of the contents of this report.)



Report No. SN0016_090-180-190-245

July 1st 2002
Revised 7/20/2006

INDEXSAR
Validation Dipoles
Type IXD-090, IXD-180, IXD-190 & IXD-245

Performance measurements

S/N: 090-0016
S/N: 180-0016
S/N: 245-0016
S/N: 190-0016

MI Manning

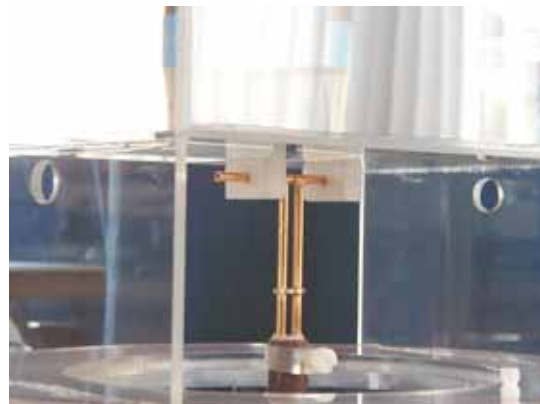

**Indexsar, Oakfield House, Cudworth Lane,
Newdigate, Surrey RH5 5DR. UK.**
Tel: +44 (0) 1306 631233 Fax: +44 (0) 1306 631834
e-mail: enquiries@indexsar.com

1. Measurement Conditions

Measurements were performed using a box-shaped phantom made of PMMA with dimensions designed to meet the accuracy criteria for reasonably-sized phantoms that do not have liquid capacities substantially in excess of the volume of liquid required to fill the Indexsar upright SAM phantoms used for SAR testing of handsets against the ear.

An HP 8753B vector network analyser was used for the return loss measurements. The dipole was placed in a special holder made of low-permittivity, low-loss materials. This holder enables the dipole to be positioned accurately in the centre of the base of the Indexsar box-phantom used for flat-surface testing and validation checks.

The validation dipoles are supplied with special spacers made from a low-permittivity, low-loss foam material. These spacers are fitted to the dipole arms to ensure that, when the dipole is offered up to the phantom surface, the spacing between the dipole and the liquid surface is accurately aligned according to the guidance in the relevant standards documentation. The spacers are rectangular with a central hole equal to the dipole arm diameter and dimensioned so that the longer side can be used to ensure a spacing of 15mm from the liquid in the phantom (for tests at 900MHz and below) and the shorter side can be used for tests at 1800MHz and above to ensure a spacing of 10mm from the liquid in the phantom. The spacers are made on a CNC milling machine with an accuracy of 1/40th mm but they may suffer wear and tear and need to be replaced periodically. The material used is Rohacell, which has a relative permittivity of approx. 1.05 and a negligible loss tangent.

The apparatus supplied by Indexsar for dipole validation tests thus includes:

Balanced dipoles for each frequency required are dimensioned according to the guidelines given in IEEE 1528 [1]. The dipoles are made from semi-rigid 50 ohm co-ax, which is joined by soldering and is gold-plated subsequently. The constructed dipoles are easily deformed, if mis-handled, and periodic checks need to be made of their symmetry.

Rohacell foam spacers designed for presenting the dipoles to 2mm thick PMMA box phantoms. These components also suffer wear and tear and should be replaced when the central hole is a loose-fit on the dipole arms or if the edges are too worn to ensure accurate alignment. The standard spacers are dimensioned for use with 2mm wall thickness (additional spacers are available for 4mm wall thickness).

2. SAR Measurement

SAR validation checks using the dipoles can be performed with the box-phantom located on the SARA2 phantom support base on the SARA2 robot system. Tests may be conducted at a feed power level of 0.25W. However, the actual power level should be recorded and used to normalise the results obtained to the standard input power conditions of 1W (forward power). The results can then be compared with Table 8.1 in [1]. Brain liquids should be used so that measurement results can be compared with the (computed) reference values tabulated in IEEE 1528.

3. Dipole handling

The dipoles are made from standard, copper-sheathed coaxial cable. In assembly, the sections are joined using ordinary soft-soldering. This is necessary to avoid excessive heat input in manufacture, which would destroy the polythene dielectric used for the cable. The consequence of the construction material and the assembly technique is that the dipoles are fragile and can be deformed by rough handling. Conversely, they can be straightened quite easily as described below:

If a dipole is suspected of being deformed, a normal workshop lathe can be used as an alignment jig to restore the symmetry. To do this, the dipole is first placed in the headstock of the lathe (centred on the plastic or brass spacers) and the headstock is rotated by hand (do NOT use the motor). A marker (lathe tool or similar) is brought up close to the end of one dipole arm and then the headstock is rotated by 0.5 rev. to check the opposing arm. If they are not balanced, judicious deformation of the arms can be used to restore the symmetry.

If a dipole has a failed solder joint, the dipole can be fixed down in such a way that the arms are co-linear and the joint re-soldered with a reasonably-powerful electrical soldering iron. Do not use gas soldering irons. After such a repair, electrical tests must be performed as described below.

Please note that, because of their construction, the dipoles are short-circuited for DC signals.

4. Performance Measurement

The dipoles are individually tested at their nominal frequency to ensure that they exhibit a return loss of less than -20dB when used with brain or body liquids.

The dipoles are designed to have low return loss ONLY when presented against a lossy-phantom at the specified distance. If the user has a Vector Network Analyser (VNA) it is best to perform a return loss measurement on a specific dipole when it is in a measurement-location against a box phantom. If this is not the case, the return loss should be measured with the dipole positioned at the specified distance from a suitable container of lossy liquid. The distances specified in the standards are 15mm from the lossy liquid (900MHz and below) and 10mm from the liquid (1500MHz and above). The Indexsar foam spacers (described above) should be used to ensure this condition during measurement.

S11 plots for the dipoles with nominal frequencies of 900MHz, 1800MHz and 2450MHz are shown below.

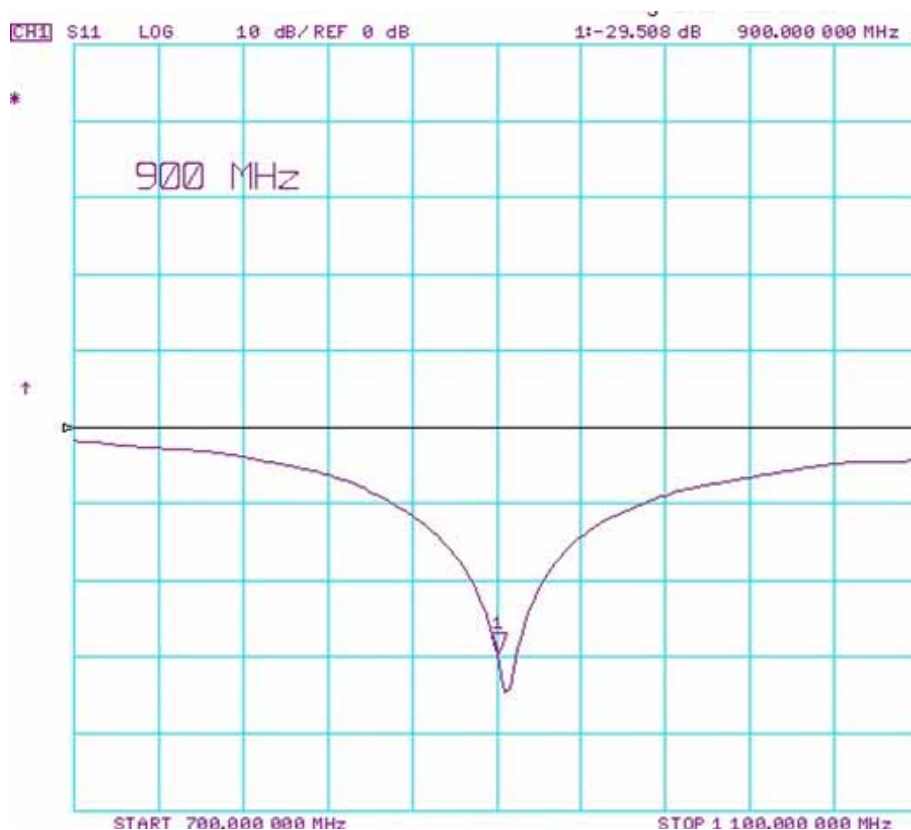

IXD-090

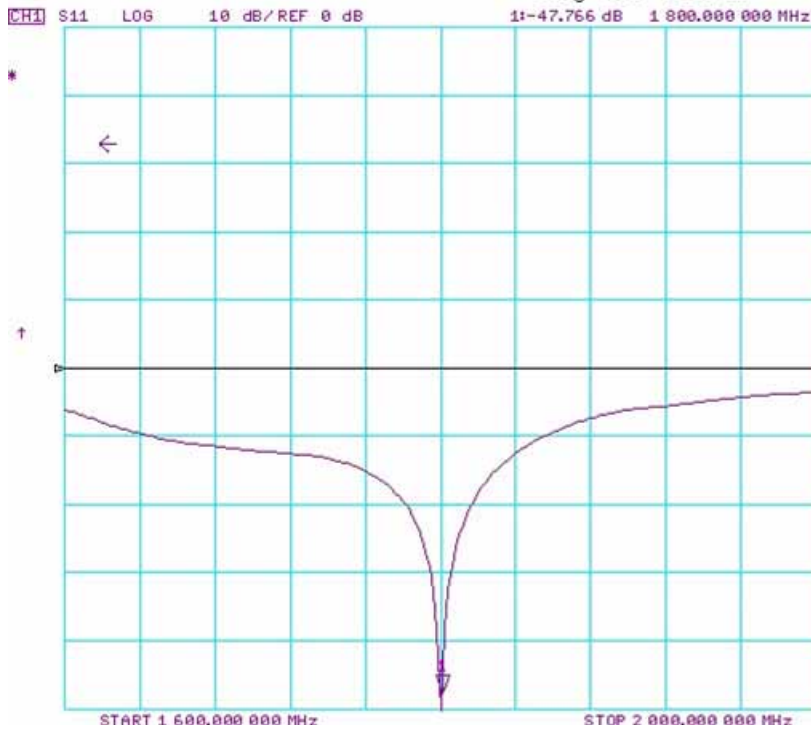

IXD-180

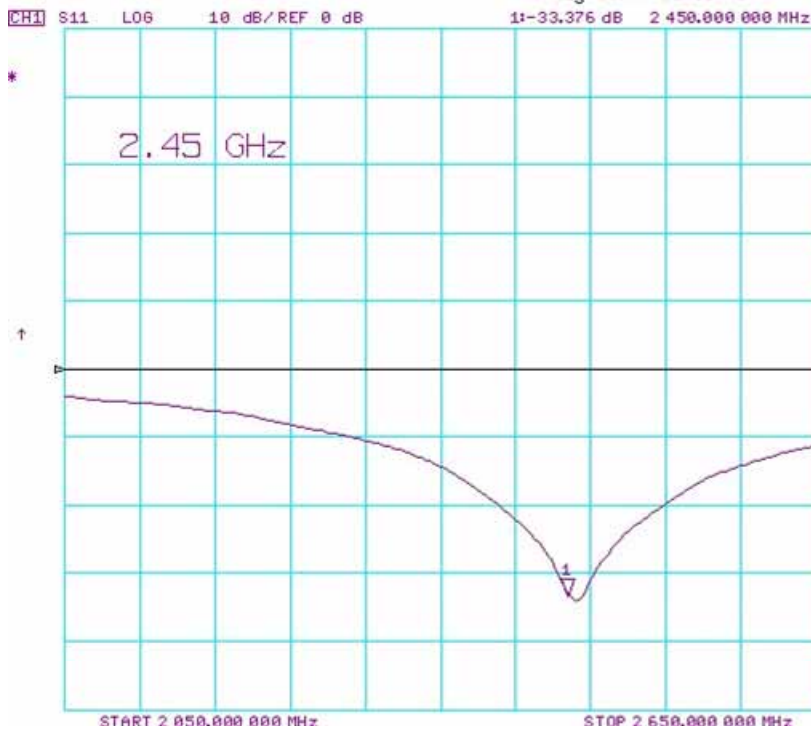

IXD-245

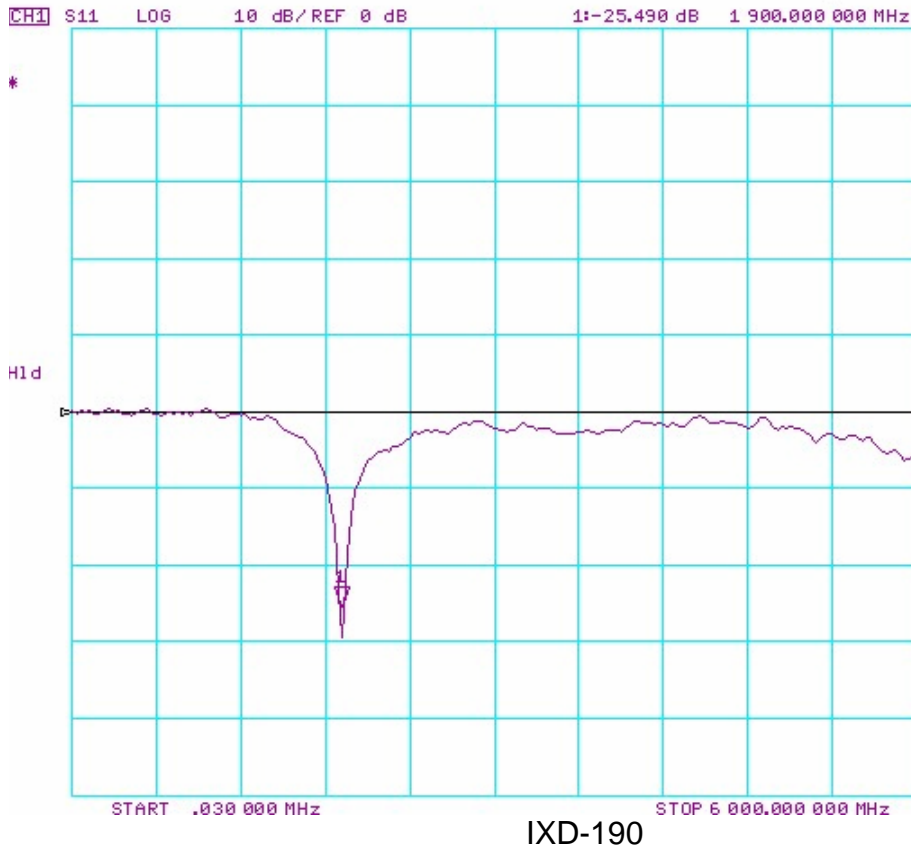

5. Tuning the dipole

The dipole dimensions are based on calculations that assumed specific liquid dielectric properties. If the liquid dielectric properties are somewhat different, the dipole tuning will also vary. A pragmatic way of accounting for variations in liquid properties is to ‘tune’ the dipole (by applying minor variations to its effective length). For this purpose, Indexasar can supply short brass tube lengths to extend the length of the dipole and thus ‘tune’ the dipole. It cannot be made shorter without removing a bit from the arm. An alternative way to tune the dipole is to use copper shielding tape to extend the effective length of the dipole. Do both arms equally.

It should be possible to tune a dipole as described, whilst in place in the measurement position as long as the user has access to a VNA for determining the return loss.

6. Reference

SAR Test Report No:
SAR_NOVAT_010_06002_FCC_850_1900_rev1

Date of Report: 8/28/2006 **Appendix C Calibration Info**

Page 11 of 31

[1] Draft recommended practice for determining the peak spatial-average specific absorption rate (SAR) in the human body due to wireless communications devices: Experimental Techniques.

SAR Test Report No:

SAR_NOVAT_010_06002_FCC_850_1900_rev1

Date of Report: 8/28/2006

Appendix C Calibration Info

Page 12 of 31

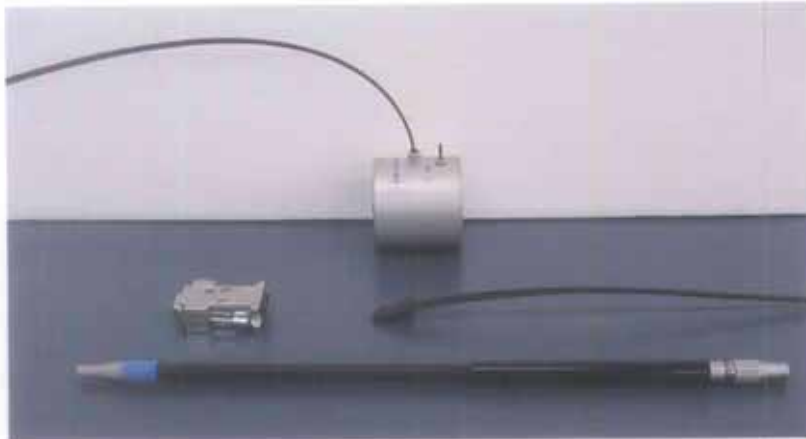
**IMMERSIBLE SAR PROBE****CALIBRATION REPORT****Part Number: IXP – 030****S/N M0016****September 2005**

Indexsar Limited
Oakfield House
Cudworth Lane
Newdigate
Surrey RH5 5BG
Tel: +44 (0) 1306 632 870
Fax: +44 (0) 1306 631 834
e-mail: enquiries@indexsar.com



Indexsar Limited
Oakfield House
Cudworth Lane
Newdigate
Surrey RH5 5BG
Tel: +44 (0) 1306 632 870
Fax: +44 (0) 1306 631 834
e-mail: enquiries@indexsar.com

**Calibration Certificate
Dosimetric E-field Probe**

Type: IXP-030

Manufacturer: IndexSAR, UK

Serial Number: M0016

Place of Calibration: IndexSAR, UK

IndexSAR Limited hereby declares that the IXP-030 Probe named above has been calibrated for conformity to the IEEE 1528 and CENELEC EN 50361 standards on the date shown below.

Date of Initial Calibration: 29th September 2005

The probe named above will require a calibration check on the date shown below.

Next Calibration Date: September 2006

The calibration was carried out using the methods described in the calibration document.
Where applicable, the standards used in the calibration process are traceable to the UK's National Physical Laboratory.

Calibrated By: *A. Binklow*

Approved By: *M. J. Mann*

Please keep this certificate with the calibration document. When the probe is sent for a calibration check, please include the calibration document.

INTRODUCTION

This Report presents measured calibration data for a particular Indexsar SAR probe (S/N M0016) and describes the procedures used for characterisation and calibration.

Indexsar probes are characterised using procedures that, where applicable, follow the recommendations of CENELEC [1] and IEEE [2] standards. The procedures incorporate techniques for probe linearisation, isotropy assessment and determination of liquid factors (conversion factors). Calibrations are determined by comparing probe readings with analytical computations in canonical test geometries (waveguides) using normalised power inputs.

Each step of the calibration procedure and the equipment used is described in the sections below.

CALIBRATION PROCEDURE

1. Objectives

The calibration process comprises three stages

- 1) Determination of the channel sensitivity factors which optimise the probe's overall rotational isotropy in 1800MHz brain fluid
- 2) At each frequency of interest, application of these channel sensitivity factors to model the exponential decay of SAR in a waveguide fluid cell, and hence derive the liquid conversion factors at that frequency
- 3) Determination of the effective tip radius and angular offset of the X channel which together optimise the probe's spherical isotropy in 900MHz brain fluid

2. Probe output

The probe channel output signals are linearised in the manner set out in Refs [1] and [2]. The following equation is utilized for each channel;

$$U_{lin} = U_{op} + U_{op}^2 / DCP \quad (1)$$

where U_{lin} is the linearised signal, U_{op} is the raw output signal in voltage units and DCP is the diode compression potential in similar voltage units.

DCP is determined from fitting equation (1) to measurements of U_{lin} versus source feed power over the full dynamic range of the probe. The DCP is a characteristic of the Schottky diodes used as the sensors. For the IXP-050 probes with CW signals the DCP values are typically 0.10V (or 20 in the voltage units used by Indexsar software, which are V*200).

In turn, measurements of E-field are determined using the following equation (where output voltages are also in units of V*200):

$$E_{liq}^2 \text{ (V/m)} = U_{linx} * \text{Air Factor}_x * \text{Liq Factor}_x + U_{liny} * \text{Air Factor}_y * \text{Liq Factor}_y + U_{linz} * \text{Air Factor}_z * \text{Liq Factor}_z \quad (3)$$

Here, "Air Factor" represents each channel's sensitivity, while "Liq Factor" represents the enhancement in signal level when the probe is immersed in tissue-simulant liquids at each frequency of interest.

3. Selecting channel sensitivity factors to optimise isotropic response

After manufacture, the first stage of the calibration process is to balance the three channels' Air Factor values, thereby optimising the probe's overall axial response ("rotational isotropy").

To do this, an 1800MHz waveguide containing head-fluid simulant is selected. Like all waveguides used during probe calibration, this particular waveguide contains two distinct sections: an air-filled launcher section, and a liquid cell section, separated by a dielectric matching window designed to minimise reflections at the air-liquid interface.

The waveguide stands in an upright position and the liquid cell section is filled with 1800MHz brain fluid to within 10 mm of the open end. The depth of liquid ensures there is negligible radiation from the waveguide open top and that the probe calibration is not influenced by reflections from nearby objects.

During the measurement, a TE₀₁ mode is launched into the waveguide by means of an N-type-to-waveguide adapter. The probe is then lowered vertically into the liquid until the tip is exactly 10mm above the centre of the dielectric window. This particular separation ensures that the probe is operating in a part of the waveguide where boundary corrections are not necessary.

Care must also be taken that the probe tip is centred while rotating.

The exact power applied to the input of the waveguide during this stage of the probe calibration is immaterial since only relative values are of interest while the probe rotates. However, the power must be sufficiently above the noise floor and free from drift.

The dedicated Indexsar calibration software rotates the probe in 10 degree steps about its axis, and at each position, an Indexsar 'Fast' amplifier samples the probe channels 500 times per second for 0.4 s. The raw U_{o/p} data from each sample are packed into 10 bytes and transmitted back to the PC controller via an optical cable. U_{linx}, U_{liny} and U_{linz} are derived from the raw U_{o/p} values and written to an Excel template.

Once data have been collected from a full probe rotation, the Air Factors are adjusted using a special Excel Solver routine to equalise the output from each channel and hence minimise the rotational isotropy. This automated approach to optimisation removes the effect of human bias.

Figure 5 represents the output from each diode sensor as a function of probe rotation angle. The directionality of the orthogonally-arranged sensors can be

checked by analysing the data using dedicated Indexsar software, which displays the data in 3D format, a representative image of which is shown in Figure 3. The left-hand side of this diagram shows the individual channel outputs after linearisation (see above). The program uses these data to balance the channel outputs and then applies an optimisation process, which makes fine adjustments to the channel factors for optimum isotropic response.

4. Determination of Conversion ("Liquid") Factors at each frequency of interest

A lookup table of conversion factors for a probe allows a SAR value to be derived at the measured frequencies, and for either brain or body fluid-simulant.

The method by which the conversion factors are assessed is based on the comparison between measured and analytical rates of decay of SAR with height above a dielectric window. This way, not only can the conversion factors for that frequency/fluid combination be determined, but an allowance can also be made for the scale and range of boundary layer effects.

The theoretical relationship between the SAR at the cross-sectional centre of the lossy waveguide as a function of the longitudinal distance (z) from the dielectric separator is given by Equation 4:

$$SAR(z) = \frac{4(P_f - P_b)}{\rho ab \delta} e^{-2z/\delta} \quad (4)$$

Here, the density ρ is conventionally assumed to be 1000 kg/m^3 , ab is the cross-sectional area of the waveguide, and P_f and P_b are the forward and reflected power inside the lossless section of the waveguide, respectively. The penetration depth δ (which is the reciprocal of the waveguide-mode attenuation coefficient) is a property of the lossy liquid and is given by Equation (5).

$$\delta = \left[\text{Re} \left\{ \sqrt{(\pi / a)^2 + j\omega\mu_0(\sigma + j\omega\epsilon_0\epsilon_r)} \right\} \right]^{-1} \quad (5)$$

where σ is the conductivity of the tissue-simulant liquid in S/m, ϵ_r is its relative permittivity, and ω is the radial frequency (rad/s). Values for σ and ϵ_r are obtained prior to each waveguide test using an Indexsar DiLine measurement kit, which uses the TEM method as recommended in [2]. σ and ϵ_r are both temperature- and fluid-dependent, so are best measured using a sample of the tissue-simulant fluid immediately prior to the actual calibration.

Wherever possible, all DiLine and calibration measurements should be made in the open laboratory at $22 \pm 2.0^\circ\text{C}$; if this is not possible, the values of σ and ϵ_r should reflect the actual temperature. Values employed for calibration are listed in the tables below.

By ensuring the liquid height in the waveguide is at least three penetration depths, reflections at the upper surface of the liquid are negligible. The power absorbed in the liquid is therefore determined solely from the waveguide forward and reflected power.

Different waveguides are used for 835/900MHz, 1800/1900MHz, 2450MHz and 5200/5800MHz measurements. Table A.1 of [1] can be used for designing calibration waveguides with a return loss greater than 20 dB at the most important frequencies used for personal wireless communications, and better than 15dB for frequencies greater than 5GHz. Values for the penetration depth for these specific fixtures and tissue-simulating mixtures are also listed in Table A.1.

According to [1], this calibration technique provides excellent accuracy, with standard uncertainty of less than 3.6% depending on the frequency and medium. The calibration itself is reduced to power measurements traceable to a standard calibration procedure. The practical limitation to the frequency band of 800 to 5800 MHz because of the waveguide size is not severe in the context of compliance testing.

During calibration, the probe is lowered carefully until it is just touching the cross-sectional centre of the dielectric window. 200 samples are then taken and written to an Excel template file before moving the probe vertically upwards. This cycle is repeated 50 times. The vertical separation between readings is determined from practical considerations of the expected SAR decay rate, and range from 1mm steps at low frequency, through 0.5mm at 2450MHz, down to 0.2mm at 5GHz.

Once the data collection is complete, a Solver routine is run which optimises the measured-theoretical fit by varying the conversion factor, and the boundary correction size and range.

5. Measurement of Spherical Isotropy

The setup for measuring the probe's spherical isotropy is shown in Figure 2.

A box phantom containing 900MHz head fluid is irradiated by a vertically-polarised, tuned dipole, mounted to the side of the phantom on the robot's seventh axis. During calibration, the spherical response is generated by rotating the probe about its axis in 20 degree steps and changing the dipole polarisation in 10 degree steps.

By using the VPM technique discussed below, an allowance can also be made for the effect of E-field gradient across the probe's spatial extent. This permits values for the probe's effective tip radius and X-channel angular offset to be modelled until the overall spherical isotropy figure is optimised.

The dipole is connected to a signal generator and amplifier via a directional coupler and power meter. As with the determination of rotational isotropy, the absolute power level is not important as long as it is stable.

The probe is positioned within the fluid so that its sensors are at the same vertical height as the centre of the source dipole. The line joining probe to dipole should be perpendicular to the phantom wall, while the horizontal

separation between the two should be small enough for VPM corrections to be applicable, without encroaching near the boundary layer of the phantom wall. VPM corrections require a knowledge of the fluid skin depth. This is measured during the calibration by recording the E-field strength while systematically moving the probe away from the dipole in 2mm steps over a 20mm range.

VPM (Virtual Probe Miniaturisation)

SAR probes with 3 diode-sensors in an orthogonal arrangement are designed to display an isotropic response when exposed to a uniform field. However, the probes are ordinarily used for measurements in non-uniform fields and isotropy is not assured when the field gradients are significant compared to the dimensions of the tip containing the three orthogonally-arranged dipole sensors.

It becomes increasingly important to assess the effects of field gradients on SAR probe readings when higher frequencies are being used. For Indexsar IXP-050 probes, which are of 5mm tip diameter, field gradient effects are minor at GSM frequencies, but are major above 5GHz. Smaller probes are less affected by field gradients and so probes, which are significantly less than 5mm diameter, would be better for applications above 5GHz.

The IndexSAR report IXS0223 describes theoretical and experimental studies to evaluate the issues associated with the use of probes at arbitrary angles to surfaces and field directions. Based upon these studies, the procedures and uncertainty analyses referred to in P1528 are addressed for the full range of probe presentation angles.

In addition, generalized procedures for correcting for the finite size of immersible SAR probes are developed. Use of these procedures enables application of schemes for virtual probe miniaturization (VPM) – allowing probes of a specific size to be used where physically-smaller probes would otherwise be required.

Given the typical dimensions of 3-channel SAR probes presently available, use of the VPM technique extends the satisfactory measurement range to higher frequencies.

CALIBRATION FACTORS MEASURED FOR PROBE S/N M0016

The probe was calibrated at 835, 900, 1800, 1900, 2450, 5200 and 5800 MHz in liquid samples representing both brain liquid and body fluid at these frequencies. The calibration was for CW signals only, and the axis of the probe was parallel to the direction of propagation of the incident field i.e. end-on to the incident radiation. The axial isotropy of the probe was measured by rotating the probe about its axis in 10 degree steps through 360 degrees in this orientation.

The reference point for the calibration is in the centre of the probe's cross-section at a distance of 1.7 mm from the probe tip in the direction of the probe amplifier. A value of 1.7 mm should be used for the tip to sensor offset distance in the software. The distance of 1.7mm for assembled probes has been confirmed by taking X-ray images of the probe tips (see Figure 8).

SAR Test Report No:

SAR_NOVAT_010_06002_FCC_850_1900_rev1

Date of Report: 8/28/2006

Appendix C Calibration Info

It is important that the diode compression point and air factors used in the software are the same as those quoted in the results tables, as these are used to convert the diode output voltages to a SAR value.

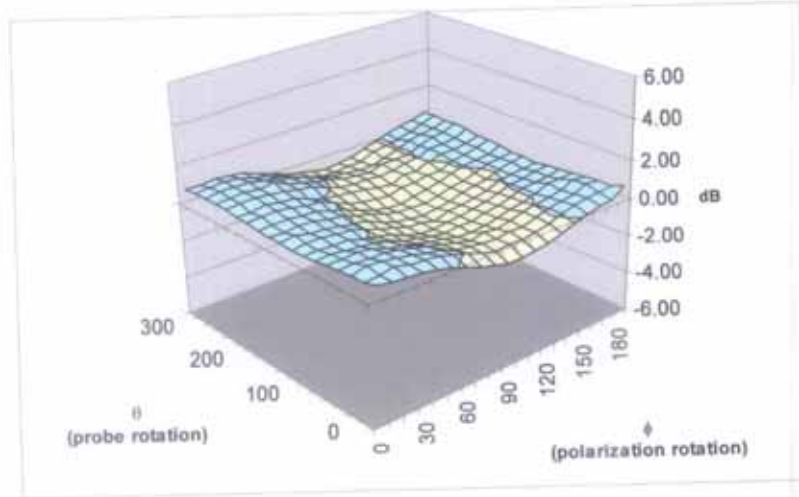

Surface Isotropy diagram of IXP-050 Probe S/N M0016 at 900MHz after VPM (rotational isotropy at side +/-0.07dB, spherical isotropy +/-0.85dB)

Probe tip radius 1.09
X Ch. Angle to red dot -12

Frequency	Head		Body	
	Bdy. Corr. - f(0)	Bdy. Corr. - d(mm)	Bdy. Corr. - f(0)	Bdy. Corr. - d(mm)
835	0.61	1.6	0.91	1.2
900	0.60	1.6	0.85	1.2
1800	1.00	0.9	1.00	1.1
1900	0.61	1.2	1.00	1.1
2450	1.00	0.9	1.00	1.0
5200	1.00	0.7	0.92	1.0
5800	1.00	0.5	1.00	0.9

SUMMARY OF CALIBRATION FACTORS FOR PROBE IXP-050 S/N M0016

Spherical isotropy measured at 900MHz	0.85	(+/-) dB
---------------------------------------	------	----------

	X	Y	Z	
Air Factors	2390	2143	2668	(V*200)
CW DCPs	20	20	20	(V*200)

Freq (MHz)	Axial Isotropy (+/- dB)		SAR ConvF (liq/air)		Notes
	Head	Body	Head	Body	
	835	-	-	0.273	
900	-	-	0.275	0.390	1,2
1800	0.07	-	0.407	0.456	1,2
1900	-	-	0.418	0.473	1,2
2450	-	-	0.433	0.490	1,2
5200	-	-	0.351	0.502	1,2
5800	-	-	0.336	0.459	1,2

Notes	
1)	Calibrations done at 22°C +/-2°C
2)	Waveguide calibration

PROBE SPECIFICATIONS

Indexsar probe M0016, along with its calibration, is compared with CENELEC and IEEE standards recommendations (Refs [1] and [2]) in the Tables below. A listing of relevant specifications is contained in the tables below:

Dimensions	S/N M0016	CENELEC [1]	IEEE [2]
Overall length (mm)	350		
Tip length (mm)	10		
Body diameter (mm)	12		
Tip diameter (mm)	3.1	8	8
Distance from probe tip to dipole centers (mm)	1.7		

Dynamic range	S/N M0016	CENELEC [1]	IEEE [2]
Minimum (W/kg)	0.01	<0.02	0.01
Maximum (W/kg) N.B. only measured to > 100 W/kg on representative probes	>100	>100	100

Isotropy (measured at 900MHz)	S/N M0016	CENELEC [1]	IEEE [2]
Axial rotation with probe normal to source (+/- dB)	0.07 Max (See table above)	0.5	0.25
Spherical isotropy covering all orientations to source (+/- dB)	0.85	1.0	0.50

Construction	Each probe contains three orthogonal dipole sensors arranged on a triangular prism core, protected against static charges by built-in shielding, and covered at the tip by PEEK cylindrical enclosure material. No adhesives are used in the immersed section. Outer case materials are PEEK and heat-shrink sleeving.
Chemical resistance	Tested to be resistant to glycol and alcohol containing simulant liquids but probes should be removed, cleaned and dried when not in use.

REFERENCES

[1] CENELEC, EN 50361, July 2001. Basic Standard for the measurement of specific absorption rate related to human exposure to electromagnetic fields from mobile phones.

[2] IEEE 1528, Recommended practice for determining the spatial-peak specific absorption rate (SAR) in the human body due to wireless communications devices: Experimental techniques.

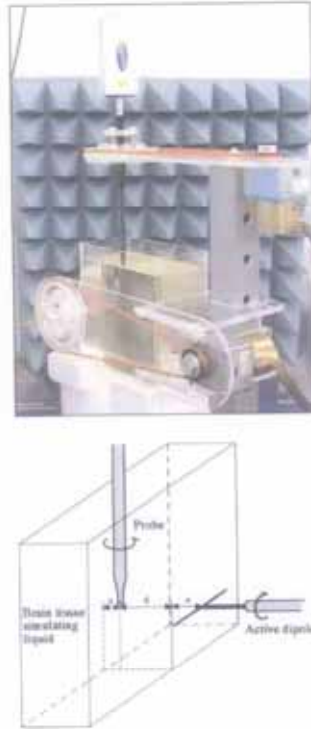

Figure 1. Spherical isotropy jig showing probe, dipole and box filled with simulated brain liquid (see Ref [2], Section A.5.2.1)

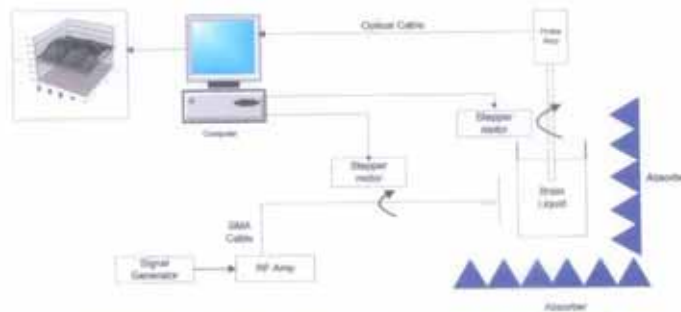

Figure 2. Schematic diagram of the test geometry used for isotropy determination

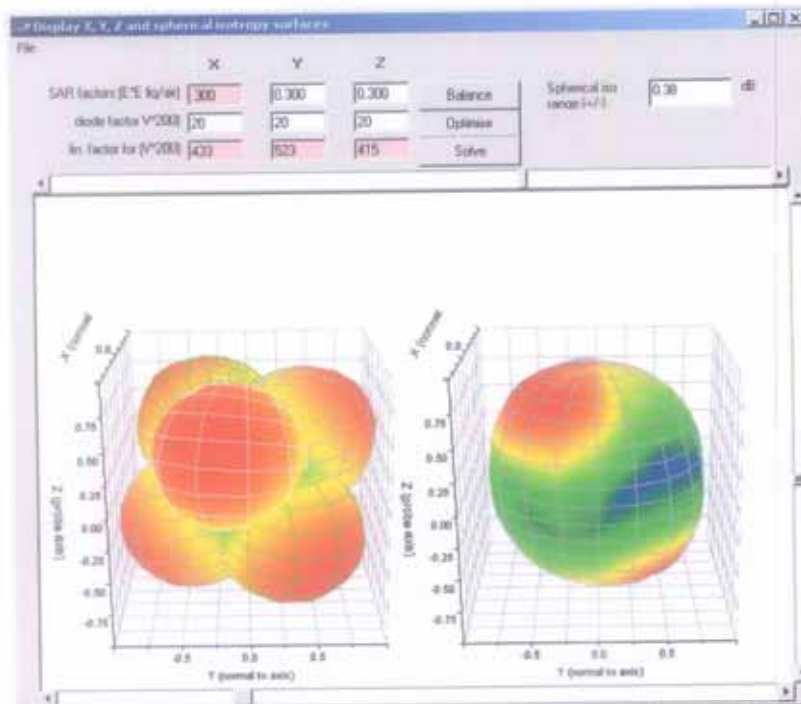

Figure 3. Graphical representation of a probe's response to fields applied from each direction. The diagram on the left shows the individual response characteristics of each of the three channels and the diagram on the right shows the resulting probe sensitivity in each direction. The colour range in the figure images the lowest values as blue and the maximum values as red. For the probe S/N M0016, this range is (+/-) 0.85 dB.

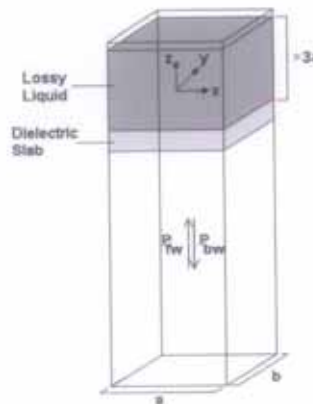

Figure 4. Geometry used for waveguide calibration (after Ref [2], Section A.3.2.2)

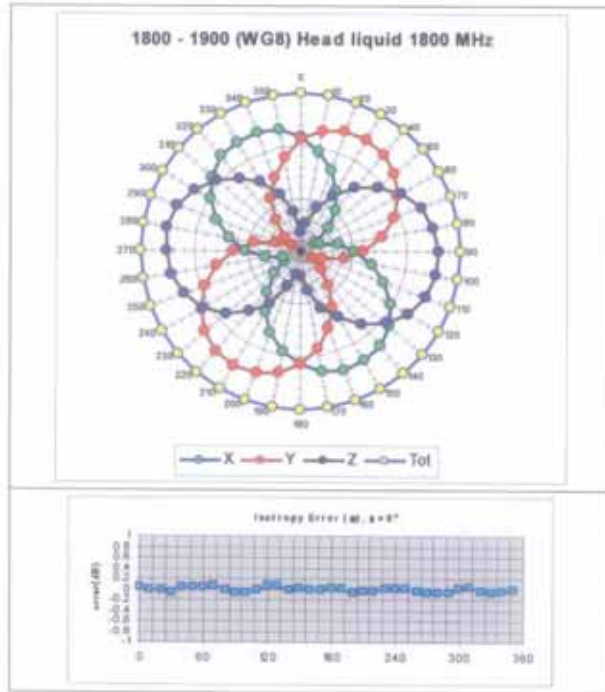

Figure 5. The rotational isotropy of probe S/N M0016 obtained by rotating the probe in a liquid-filled waveguide at 1800 MHz.

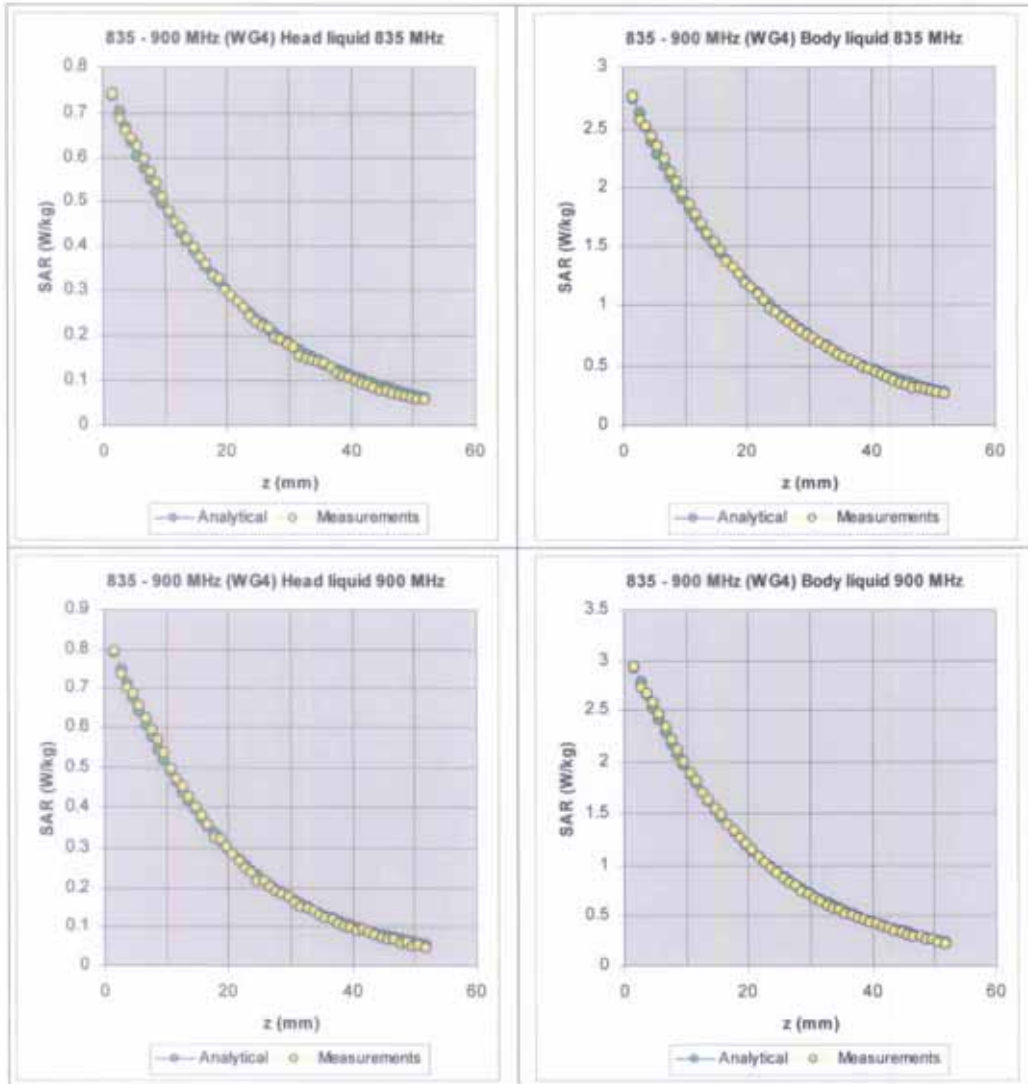
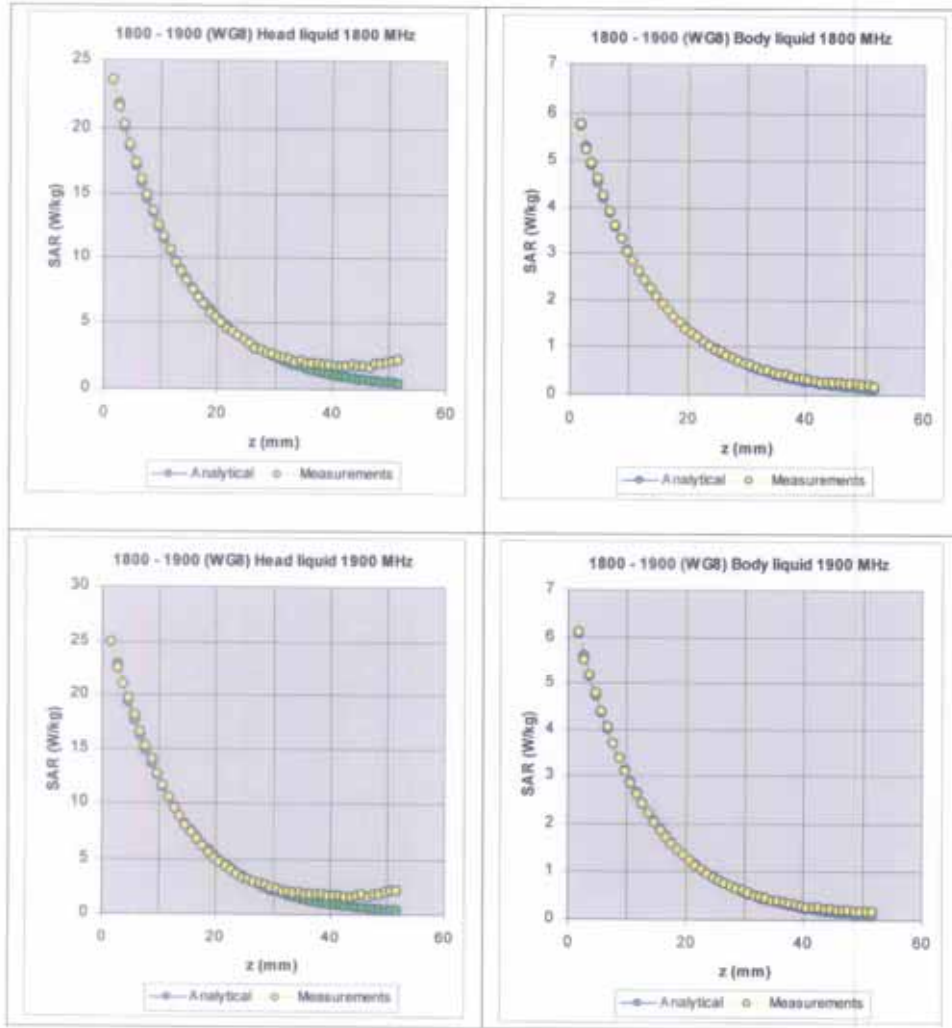
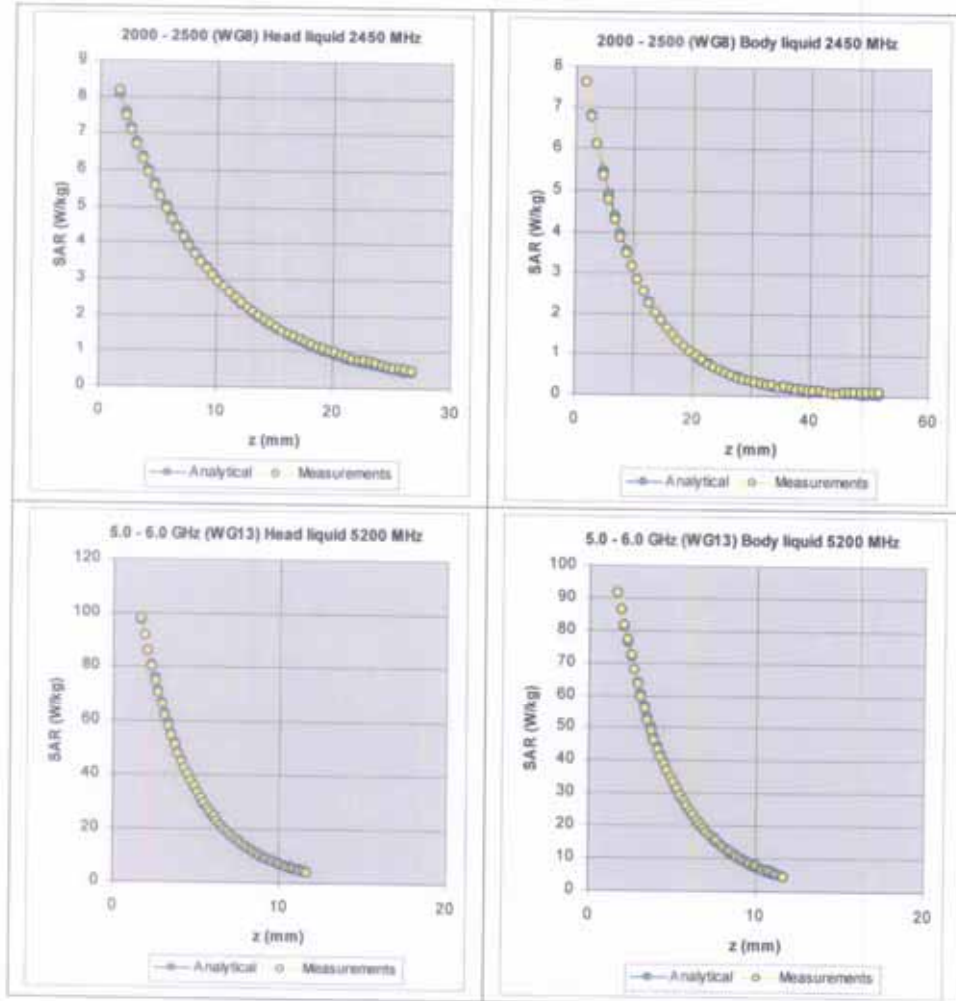

Figure 6. The measured SAR decay function along the centreline of the WG4 waveguide with conversion factors adjusted to fit to the theoretical function for the particular dimension, frequency, power and liquid properties employed.





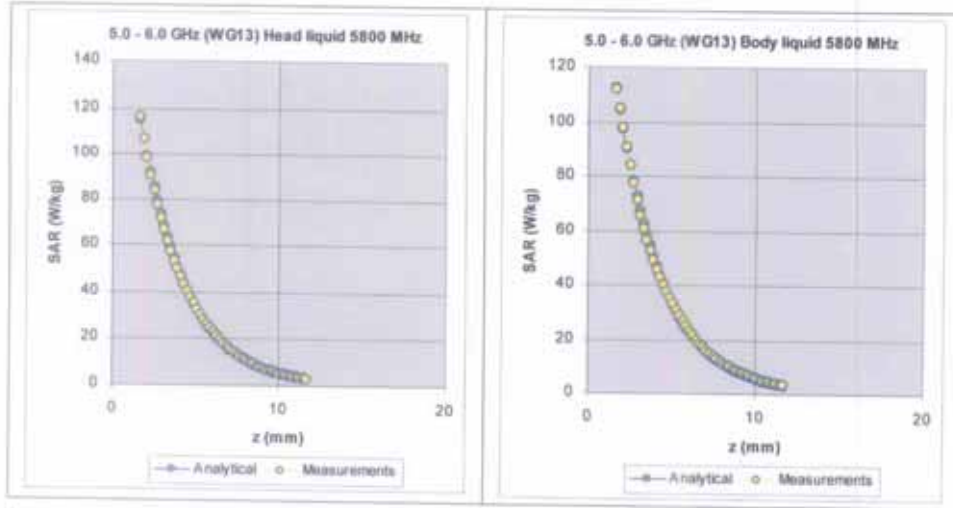

Figure 7. The measured SAR decay function along the centreline of the R22 waveguide with conversion factors adjusted to fit to the theoretical function for the particular dimension, frequency, power and liquid properties employed.

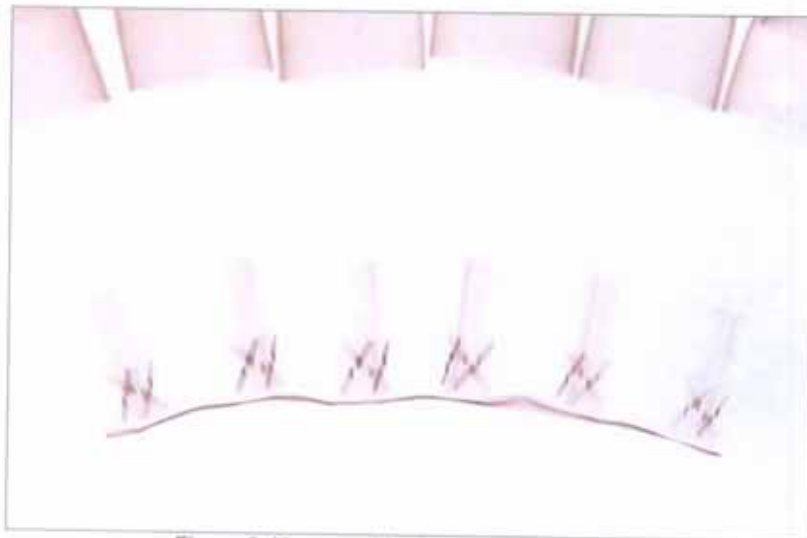

Figure 8: X-ray positive image of 5mm probes

SAR Test Report No:

SAR_NOVAT_010_06002_FCC_850_1900_rev1

Date of Report: 8/28/2006

Appendix C Calibration Info

Page 31 of 31

Table indicating the dielectric parameters of the liquids used for calibrations at each frequency

Liquid used	Relative permittivity (measured)	Conductivity (S/m) (measured)
835 MHz BRAIN	42.64	0.89
835 MHz BODY	56.84	0.94
900 MHz BRAIN	41.87	0.95
900 MHz BODY	56.29	1.01
1800 MHz BRAIN	38.89	1.36
1800 MHz BODY	54.70	1.56
1900 MHz BRAIN	38.44	1.45
1900 MHz BODY	54.34	1.66
2450 MHz BRAIN	39.66	2.02
2450 MHz BODY	54.63	2.18
5200 MHz BRAIN	33.13	5.05
5200 MHz BODY	53.02	5.98
5800 MHz BRAIN	31.70	5.79
5800 MHz BODY	51.21	7.10