



# Partial Test Report

**Test report no.:** 22097768-28470-1

**Date of issue:** 2023-01-24

**Test result:** The test item - **passed** - and complies with below listed standards.

## Applicant

HELLA GmbH & Co. KGaA

## Manufacturer

HELLA GmbH & Co. KGaA

## Test Item

RS5.3A

## RF-Spectrum Testing according to:

### FCC 47 CFR Part 95

Personal radio services,  
Subpart M - The 76-81 GHz Band Radar Service

Tested by  
(name, function, signature)

*Karsten Gerald*  
Lab Manager RF

  
signature

Approved by  
(name, function, signature)

*Andreas Bender*  
Deputy Managing Director

  
signature

<b>Applicant and Test item details</b>	
<b>Applicant</b>	HELLA GmbH & Co. KGaA Rixbecker Strasse 75 59552, Lippstadt, Germany Phone: +49 2941 380 Fax: +49 2941 387133
<b>Manufacturer</b>	HELLA GmbH & Co. KGaA Rixbecker Strasse 75 59552, Lippstadt, Germany
<b>Test item description</b>	Advanced Driver Assistance System
<b>Model/Type reference</b>	RS5.3A
<b>FCC ID</b>	NBG01RS53A
<b>Frequency</b>	76.0 GHz to 77.0 GHz
<b>Antenna</b>	Microstrip patch array
<b>Power supply</b>	9.0 to 18.0 V DC
<b>Temperature range</b>	-40 °C to +85 °C

### Disclaimer and Notes

The content of this test report relates to the mentioned test sample(s) only.  
Without a written permit of IBL-Lab GmbH, this test report shall not be reproduced, except in full.

The last valid version is available at TAMSys®.

Copyright ©: All rights reserved by IBL-Lab GmbH

Within this test report, a  point /  comma is used as a decimal separator.  
If otherwise, a detailed note is added adjoined to its use.

IBL-Lab GmbH does not take test samples. The samples used for testing are provided by the applicant.

Decision rule:

Decision rule based on simple acceptance without guard bands, binary statement, based on mutually agreed uncertainty tolerances with expansion factor k=2 according to ILAC-G8:09/2019

# 1 TABLE OF CONTENTS

1	TABLE OF CONTENTS .....	3
2	GENERAL INFORMATION .....	4
2.1	Administrative details .....	4
2.2	Possible test case verdicts .....	4
2.3	Observations .....	5
2.4	Opinions and interpretations .....	5
2.5	Revision history .....	5
2.6	Further documents .....	5
3	ENVIRONMENTAL & TEST CONDITIONS .....	6
3.1	Environmental conditions .....	6
3.2	Normal and extreme test conditions .....	6
4	TEST STANDARDS AND REFERENCES .....	6
5	EQUIPMENT UNDER TEST (EUT) .....	7
5.1	Product description .....	7
5.2	Description of test item .....	7
5.3	Technical data of test item .....	7
5.4	Additional information .....	7
5.5	Operating conditions .....	8
5.6	Test modes .....	9
5.7	Antenna characteristics .....	10
6	SUMMARY OF TEST RESULTS .....	11
7	TEST RESULTS .....	12
7.1	RF power output (§2.1046 & §95.3367) .....	12
7.2	Modulation characteristics (§2.1047 & KDB 653005 D01 76-81 GHz Radars) .....	17
7.3	Occupied bandwidth (§2.1049 & §95.3379) .....	18
7.4	Field strength of spurious radiation (§2.1053 & §95.3379) .....	23
8	Test Setup Description .....	33
8.1	Semi Anechoic Chamber with Ground Plane .....	34
8.2	Fully Anechoic Chamber .....	36
8.3	Radiated measurements > 18 GHz .....	38
8.4	Radiated measurements > 50 GHz .....	38
8.5	Radiated measurements under extreme conditions .....	38
9	Measurement procedures .....	40
9.1	Radiated spurious emissions from 9 kHz to 30 MHz .....	40
9.2	Radiated spurious emissions from 30 MHz to 1 GHz .....	41
9.3	Radiated spurious emissions from 1 GHz to 18 GHz .....	42
9.4	Radiated spurious emissions above 18 GHz .....	43
10	MEASUREMENT UNCERTAINTIES .....	44

## 2 GENERAL INFORMATION

### 2.1 Administrative details

Testing laboratory	<b>IBL-Lab GmbH</b> Heinrich-Hertz-Allee 7 66386 St. Ingbert / Germany Fon: +49 6894 38938-0 Fax: +49 6894 38938-99 URL: <a href="http://www.ib-lenhardt.de">www.ib-lenhardt.de</a> E-Mail: <a href="mailto:info@ib-lenhardt.de">info@ib-lenhardt.de</a>
Accreditation	<p>The testing laboratory is accredited by Deutsche Akkreditierungsstelle GmbH (DAkKS) in compliance with DIN EN ISO/IEC 17025:2018.</p> <p>Scope of testing and registration number:</p> <ul style="list-style-type: none"> <li>Electronics, EMC, Radio <a href="#">D-PL-21375-01-01</a></li> <li>Electromagnetic Compatibility and Telecommunication (FCC requirements) Testing Laboratory Designation Number <a href="#">D-PL-21375-01-02</a> DE0024</li> <li>Telecommunication (TC) and Electromagnetic Compatibility (EMC) for Canadian Standards <a href="#">D-PL-21375-01-03</a> ISED Company Number 27156 Testing Laboratory CAB Identifier DE0020</li> </ul> <p>Website DAkKS: <a href="https://www.dakks.de/">https://www.dakks.de/</a></p> <p>The Deutsche Akkreditierungsstelle GmbH (DAkKS) is also a signatory to the <a href="#">ILAC Mutual Recognition Arrangement</a></p>
Testing location	<b>IBL-Lab GmbH</b> Heinrich-Hertz-Allee 7 66386 St. Ingbert / Germany
Date of receipt of test samples	2022-09-13
Start – End of tests	2022-10-17 – 2022-10-20

### 2.2 Possible test case verdicts

Test sample meets the requirements	P (PASS)
Test sample does not meet the requirements	F (FAIL)
Test case does not apply to the test sample	N/A (Not applicable)
Test case not performed	N/P (Not performed)

## 2.3 Observations

No additional observations other than the reported observations within this test report have been made.

## 2.4 Opinions and interpretations

No appropriate opinions or interpretations according ISO/IEC 17025:2017 clause 7.8.7 are within this test report.

## 2.5 Revision history

**-0 Initial Version**

**-1 Revision:**

**Chapter 5.4: tested variant added**

**This test report 22097768-28470-1 replaces the previous test report 22097768-28470-0.**

**Utilisation, publication and control of previous report editions is under responsibility of the applicant.**

## 2.6 Further documents

List of further applicable documents belonging to the present test report:

External photographs of EUT: TR-Annex-EP\_22097768-28470-0\_Hella\_RS5.3A\_FCC95M.pdf

Internal photographs of EUT: TR-Annex-IP\_22097768-28470-0\_Hella\_RS5.3A\_FCC95M.pdf

Test setup photographs: TR-Annex-TSP\_22097768-28470-0\_Hella\_RS5.3A\_FCC95M.pdf

### 3 ENVIRONMENTAL & TEST CONDITIONS

#### 3.1 Environmental conditions

Temperature	20°C ± 5°C
Relative humidity	25-75% r.H.
Barometric Pressure	860-1060 mbar
Power supply	230 V AC ± 5%

#### 3.2 Normal and extreme test conditions

	minimum	normal	maximum
Temperature	-/-	20 °C	-/-
Relative humidity	-/-	45 % r.h.	-/-
Power supply	-/-	13.5 V DC	-/-

### 4 TEST STANDARDS AND REFERENCES

Test standard (accredited)	Description
FCC 47 CFR Part 95	Personal radio services, Subpart M - The 76-81 GHz Band Radar Service

Reference	Description
ANSI C63.4-2014	American National Standard for Methods of Measurement of Radio-Noise Emissions from Low-Voltage Electrical and Electronic Equipment in the Range of 9 kHz to 40 GHz
ANSI C63.10-2013	American National Standard of Procedures for Compliance Testing of Unlicensed Wireless Devices
ANSI C63.26-2015	American National Standard for Compliance Testing of Transmitters Used in Licensed Radio Services
KDB 653005 D01, V01, R02	Equipment Authorization Guidance for 76-81 GHz Radar Devices

## 5 EQUIPMENT UNDER TEST (EUT)

### 5.1 Product description

Advanced Driver Assistance System

### 5.2 Description of test item

<b>Model name*</b>	RS5.3A
<b>Serial number*</b>	6D22173002B00000
<b>PCB identifier*</b>	N/A
<b>Hardware status*</b>	C1.0
<b>Software status*</b>	X072

\*: as declared by applicant

### 5.3 Technical data of test item

<b>Operational frequency band*</b>	76.0 GHz to 77.0 GHz
<b>Type of radio transmission*</b>	modulated carrier
<b>Modulation type*</b>	FMCW
<b>Number of channels*</b>	1
<b>Channel bandwidth*</b>	< 1 GHz
<b>Channel spacing*</b>	N/A
<b>Receiver category*</b>	N/A
<b>Receiver bandwidth*</b>	N/A
<b>Duty cycle*</b>	~35%
<b>Antenna*</b>	Microstrip patch array
<b>Antenna gain*</b>	15 dBi
<b>Rated RF output power*</b>	< 50 dBm
<b>Power supply*</b>	9.0 to 18.0 V DC
<b>Temperature range*</b>	-40 °C to +85 °C

\*: as declared by applicant

### 5.4 Additional information

<b>Tested variant</b>	SRR ETH
<b>Model differences</b>	none
<b>Ancillaries tested with</b>	none
<b>Additional equipment used for testing</b>	notebook, special test software and CAN interface for Mode 1 to Mode 6

## 5.5 Operating conditions

Following information is derived from document “RS5.3A technical\_description\_revAJ3\_with\_SBZA-1654610750.pdf”, provided by applicant.

### Chirp Modulation Data

Start of a radar cycle	
Chirp group 5: Antenna	Tx1
Chirp group 5: Chirp center frequency	76.256 GHz or 76.586 GHz or 76.804 GHz (*)
Chirp group 5: Bandwidth	300 MHz
Chirp group 5: No of chirps	256
Chirp group 5: Duration of a single chirp	34 $\mu$ s
Chirp group 2: Antenna	Tx1
Chirp group 2: Chirp center frequency	76.586 GHz
Chirp group 2: Bandwidth	870 MHz
Chirp group 2: No of chirps	16
Chirp group 2: Duration of a single chirp	33 $\mu$ s
Time slot with no emission	12.5 ms
Chirp group 4: Antenna	Tx1 / Tx2 alternating
Chirp group 4: Chirp center frequency	76.481 GHz or 76.679 GHz (*)
Chirp group 4: Bandwidth	720 MHz
Chirp group 4: No of chirps	84 / 84
Chirp group 4: Duration of a single chirp	45 $\mu$ s
Chirp group 6: Antenna	Tx1
Chirp group 6: Chirp center frequency	76.040 GHz
Chirp group 6: Bandwidth	0 MHz (CW)
Chirp group 6: No of chirps	1
Chirp group 6: Duration of a single chirp	236 $\mu$ s
Time slot with no emission	20 ms
End of radar cycle	
Duration of one radar cycle	approx. 50 ms
Duty cycle	approx. 35 %

(\*) Center frequency is changed approx. every two minutes or if interference is detected.

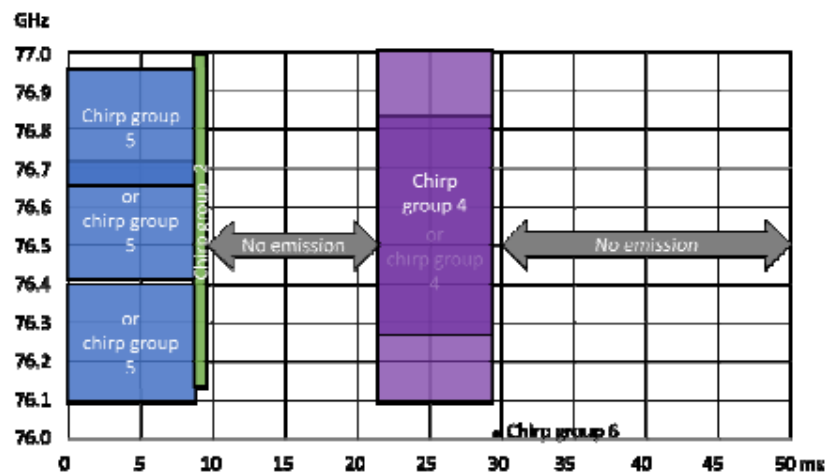

Illustration of time dependent modulation within one radar cycle.



<b>5.6 Test modes</b>	
<b>Mode 0</b>	Normal operation mode as described under chapter 5.5 This mode was used only for testing spurious emissions!
<b>Mode 1</b>	Chirp group 5 low with Chirp group 4 low
<b>Mode 2</b>	Chirp group 5 low with Chirp group 4 high
<b>Mode 3</b>	Chirp group 5 mid with Chirp group 4 low
<b>Mode 4</b>	Chirp group 5 mid with Chirp group 4 high
<b>Mode 5</b>	Chirp group 5 high with Chirp group 4 low
<b>Mode 6</b>	Chirp group 5 high with Chirp group 4 high

## 5.7 Antenna characteristics

### Antenna properties:

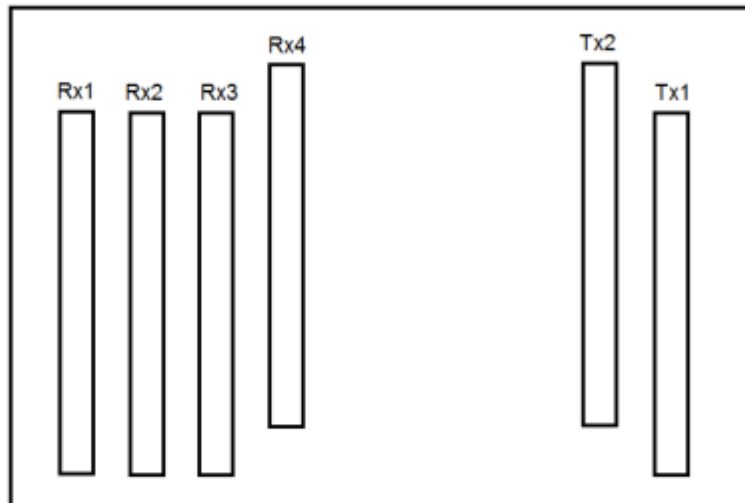
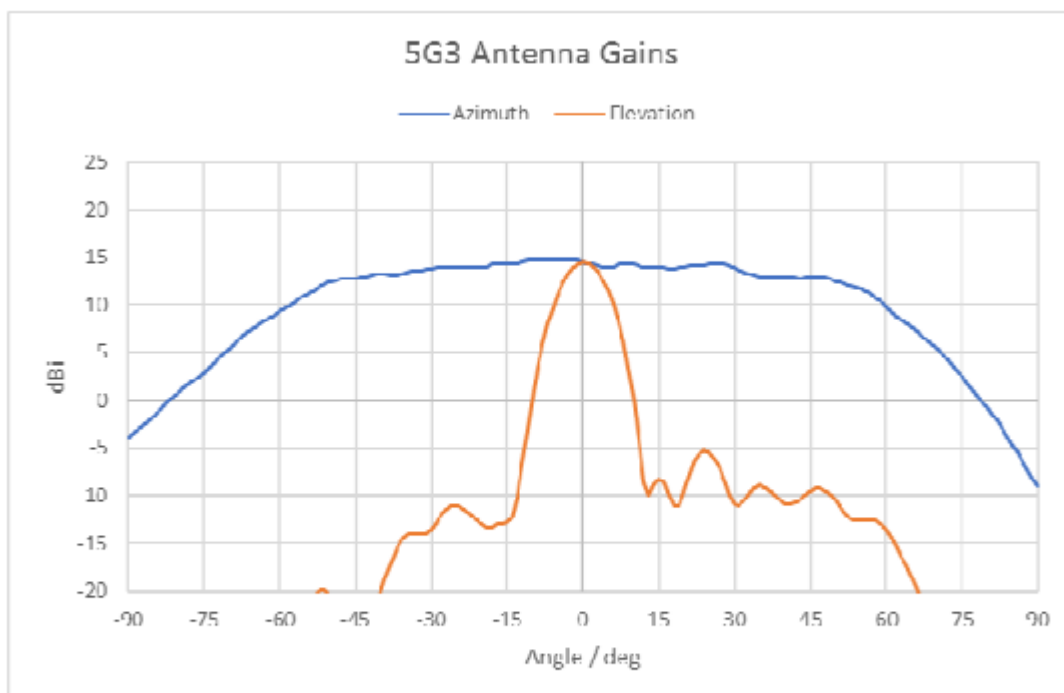

Illustration of Tx and Rx antennas inside the EUT. Each antenna consists of a linear patch array with horizontal polarisation.



Antenna characteristics in azimuth and in elevation. The peak gain is approx. 15 dBi.

## 6 SUMMARY OF TEST RESULTS

### Test specification

FCC 47 CFR Part 95 – Subpart M

Clause	Requirement / Test case	Test Conditions	Result / Remark	Verdict
§2.1046 §95.3367 (a) (b)	RF power output	Nominal	19.93 dBm mean 25.76 dBm peak	P
§2.1047	Modulation characteristics	Nominal	-	P
§2.1049 §95.3379 (b)	Occupied bandwidth	Nominal	955.95 MHz	P
§2.1051	Spurious emissions at antenna terminals	Nominal	see note	N/A
§2.1053 §95.3379 (a)(1) §95.3379 (a)(2) §95.3379 (a)(3)	Field strength of spurious radiation	Nominal	< limit	P
§2.1055 §95.3379 (b)	Frequency stability	-	-	N/P

### Notes

#### FCC's Millimeter Wave Test Procedures:

I. A radiated method of measurements in order to demonstrate compliance with the various regulatory requirements has been chosen in consideration of test equipment availability and the limitations of many external harmonic mixers. A conducted method of measurement could be employed if EUT and mixer waveguides both are accessible and of the same type (WG number) and if waveguide sections and transitions can be found. Another potential problem is that the peak power output may exceed the +20 dBm input power limit of many commercially available mixers. For these reasons a radiated method is preferred.

### Comments and observations

*The present test report documents a partial testing only, based on previous RF-test report evaluated in 12-2021.*

## 7 TEST RESULTS

### 7.1 RF power output (§2.1046 & §95.3367)

#### Description

§2.1046 Measurements required: RF power output.

(a) For transmitters other than single sideband, independent sideband and controlled carrier radiotelephone, power output shall be measured at the RF output terminals when the transmitter is adjusted in accordance with the tune-up procedure to give the values of current and voltage on the circuit elements specified in §2.1033(c)(8). The electrical characteristics of the radio frequency load attached to the output terminals when this test is made shall be stated.

#### Limits

§95.3367 76-81 GHz Band Radar Service radiated power limits

The fundamental radiated emission limits within the 76-81 GHz band are expressed in terms of Equivalent Isotropically Radiated Power (EIRP) and are as follows:

(a) The maximum power (EIRP) within the 76-81 GHz band shall not exceed 50 dBm based on measurements employing a power averaging detector with a 1 MHz Resolution Bandwidth (RBW).

(b) The maximum peak power (EIRP) within the 76-81 GHz band shall not exceed 55 dBm based on measurements employing a peak detector with a 1 MHz RBW.

#### Test procedure

##### Mean Power

##### Method with spectrum analyser

A spectrum analyser with the following settings is used as measuring receiver in the test set-up:

- Start frequency: lower than the lower edge of the operating frequency range.
- Stop frequency: higher than the upper edge of the operating frequency range.
- Resolution bandwidth: 1 MHz.
- Video bandwidth: 3 MHz.
- Detector mode: RMS.
- Display mode: clear write.
- Averaging time: larger than one EUT cycle time.
- Sweep time: averaging time × number of sweep points.

Channel Power function needs to be used to calculate the average power. Boundaries for the calculation needs to be defined. This is typically the operating frequency range.

##### Method with power meter

The power meter shall be connected to the measurement antenna. The frequency correction factor shall be taken into account. The power meter shall be a true RMS power meter. The measurement time shall be equal or longer than the EUT cycle time.

KDB 653005 D01 76-81 GHz Radars v01r02, 4. b)

The maximum fundamental emission power (EIRP) shall be measured using a power averaging (rms) detector with a 1 MHz resolution bandwidth (RBW) and integrated over the full 99% occupied bandwidth (OBW) to obtain the data necessary to demonstrate compliance to the 50 dBm limit.

**Test procedure**

**Peak Power**

*Method with a spectrum analyser*

A spectrum analyser with the following settings is used as measuring receiver in the test set-up:

- Start frequency: lower than the lower edge of the operating frequency range.
- Stop frequency: higher than the upper edge of the operating frequency range.
- Resolution bandwidth: 1 MHz.
- Video bandwidth: 3 MHz.
- Detector mode: Peak detector.
- Display mode: Maxhold.
- Sweep time: EUT cycle time x number of sweep points.
- Measurement is done until trace is stabilised.

The peak power to be considered is the maximum value recorded.

KDB 653005 D01 76-81 GHz Radars v01r02, 4. c)

The maximum peak fundamental emission power (EIRP) measurement shall be performed by sweeping over the transmitted occupied bandwidth using a positive peak power detector with peak hold activated, and a 1 MHz RBW. Power integration is not to be used in performing this measurement. The resultant peak power spectral density (maximum in any 1 MHz) data shall be used to demonstrate compliance to the 55 dBm/MHz limit.

Peak power measurements of swept frequency radar implementations (e.g., high sweep rate FMCW) may require a desensitization correction factor to be applied to the measurement results. See relevant Application Note(s) from the measurement instrumentation vendor for details.

**Test procedure used:** Method with Spectrum Analyzer

**Test setup:** 8.3

**Test results**

EUT mode	Test distance	Radiated Mean Power (EIRP) [dBm]	Radiated Peak Power (EIRP) [dBm]
Mode 1	1 m	17.14	<b>25.76</b>
Mode 2	1 m	19.92	25.66
Mode 3	1 m	<b>19.93</b>	25.67
Mode 4	1 m	19.82	25.72
Mode 5	1 m	19.59	25.62
Mode 6	1 m	19.82	25.71

**Note:** Measurement plots of Peak EIRP see chapter 7.3 Occupied bandwidth

Plot no. 1: Mean Power EIRP, RMS detector / Channel Power, EUT Mode 1



Plot no. 2: Mean Power EIRP, RMS detector / Channel Power, EUT Mode 2



Plot no. 3: Mean Power EIRP, RMS detector / Channel Power, EUT Mode 3



Plot no. 4: Mean Power EIRP, RMS detector / Channel Power, EUT Mode 4



Plot no. 5: Mean Power EIRP, RMS detector / Channel Power, EUT Mode 5



Plot no. 6: Mean Power EIRP, RMS detector / Channel Power, EUT Mode 6





**7.2 Modulation characteristics (§2.1047 & KDB 653005 D01 76-81 GHz Radars)**

**Description**

§2.1047 Modulation characteristics

(d) Other types of equipment. A curve or equivalent data which shows that the equipment will meet the modulation requirements of the rules under which the equipment is to be licensed.

KDB 653005 D01 76-81 GHz Radars v01r02, 3. g)

Concerning the Section 2.1047 modulation characteristics requirement, the following information should be provided:

- 1) Pulsed radar: pulse width and pulse repetition frequency (if PRF is variable, then report maximum and minimum values).
- 2) Non-pulsed radar (e.g., FMCW): modulation type (i.e., sawtooth, sinusoid, triangle, or square wave) and sweep characteristics (sweep bandwidth, sweep rate, sweep time).

**Statement of applicant / manufacturer concerning modulation characteristics of EUT**

See section 5.5

### 7.3 Occupied bandwidth (§2.1049 & §95.3379)

**Description**

§2.1049 Measurements required: Occupied bandwidth.

The occupied bandwidth, that is the frequency bandwidth such that, below its lower and above its upper frequency limits, the mean powers radiated are each equal to 0.5 percent of the total mean power radiated by a given emission shall be measured.

**Limits**

§95.3379 (b)

Fundamental emissions (i.e. 99% emission bandwidth) must be contained within the frequency bands specified in this section during all conditions of operation.

**Test procedure**

ANSI C63.26, 5.4.4

The occupied bandwidth is the frequency bandwidth such that, below its lower and above its upper frequency limits, the mean powers are each equal to 0.5% of the total mean power of the given emission.

The following procedure shall be used for measuring 99% power bandwidth:

- a) The instrument center frequency is set to the nominal EUT channel center frequency. The frequency span for the spectrum analyzer shall be between 1.5 times and 5.0 times the OBW.
- b) The nominal IF filter bandwidth (3 dB RBW) shall be in the range of 1% to 5% of the OBW, and VBW shall be approximately three times the RBW, unless otherwise specified by the applicable requirement.
- c) Set the reference level of the instrument as required, keeping the signal from exceeding the maximum input mixer level for linear operation. In general, the peak of the spectral envelope shall be more than [10 log (OBW/RBW)] below the reference level. Specific guidance is given in 4.1.5.2.  
 Note: Step a) through step c) may require iteration to adjust within the specified tolerances.
- d) Set the detection mode to peak, and the trace mode to max-hold.
- e) If the instrument does not have a 99% OBW function, recover the trace data points and sum directly in linear power terms. Place the recovered amplitude data points, beginning at the lowest frequency, in a running sum until 0.5% of the total is reached. Record that frequency as the lower OBW frequency. Repeat the process until 99.5% of the total is reached and record that frequency as the upper OBW frequency. The 99% power OBW can be determined by computing the difference these two frequencies.
- f) The OBW shall be reported and plot(s) of the measuring instrument display shall be provided with the test report. The frequency and amplitude axis and scale shall be clearly labeled. Tabular data can be reported in addition to the plot(s)

KDB 653005 D01 76-81 GHz Radars v01r02, 4. d)

The occupied bandwidth of the radar device shall be measured, reported, and shown to be fully contained within the designated 76-81 GHz frequency band under normal operating conditions as well as under those extreme ambient temperature and input voltage conditions as described in Section 2.1057.

The OBW measurement of an FMCW radar shall be performed with the transmitter operating in normal mode (i.e., with frequency sweep or step active).

**Note**

Measurements with the peak detector are also suitable to demonstrate compliance of an EUT, as long as the required resolution bandwidth is used, because peak detection will yield amplitudes equal to or greater than amplitudes measured with RMS detector. The measurement data from a spectrum analyser peak detector will represent the worst-case results (see ANSI C63.26, chapter D2: general considerations).

**Test setup:** 8.3, 8.4

Test results				
EUT mode	Test conditions	f <sub>L</sub> [GHz]	f <sub>H</sub> [GHz]	99% OBW [MHz]
Mode 1	Normal	76.027	76.967	939.750
Mode 2	Normal	76.027	76.983	<b>955.951</b>
Mode 3	Normal	76.027	76.967	940.112
Mode 4	Normal	76.027	76.981	954.249
Mode 5	Normal	76.027	76.967	940.008
Mode 6	Normal	76.027	76.982	955.075
see plots for ambient/normal temperature				

Plot no. 7: OBW, Peak detector, Mode 1

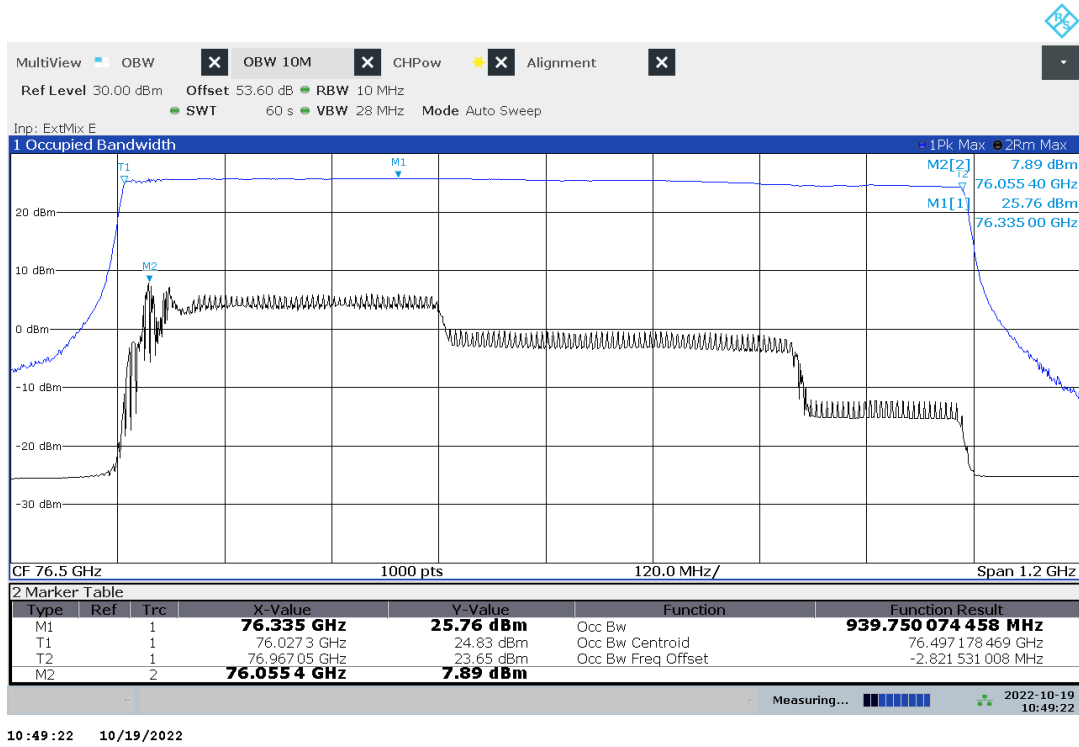

10:49:22 10/19/2022

Plot no. 8: OBW, Peak detector, Mode 2

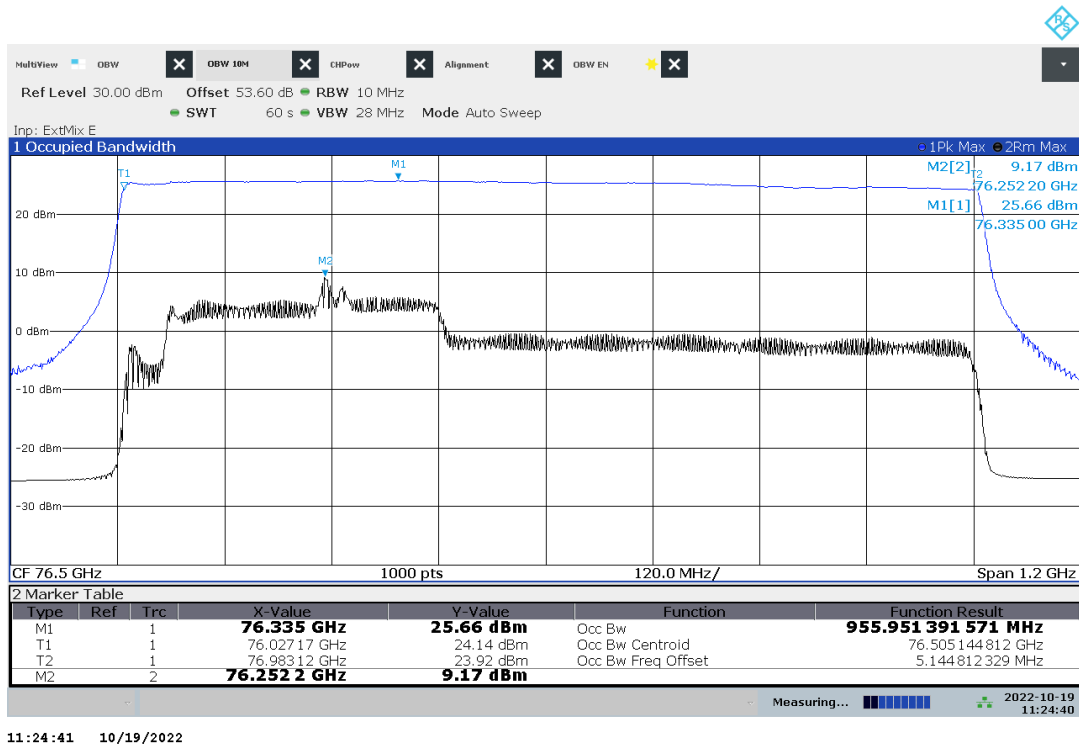

11:24:41 10/19/2022

Plot no. 9: OBW, Peak detector, Mode 3

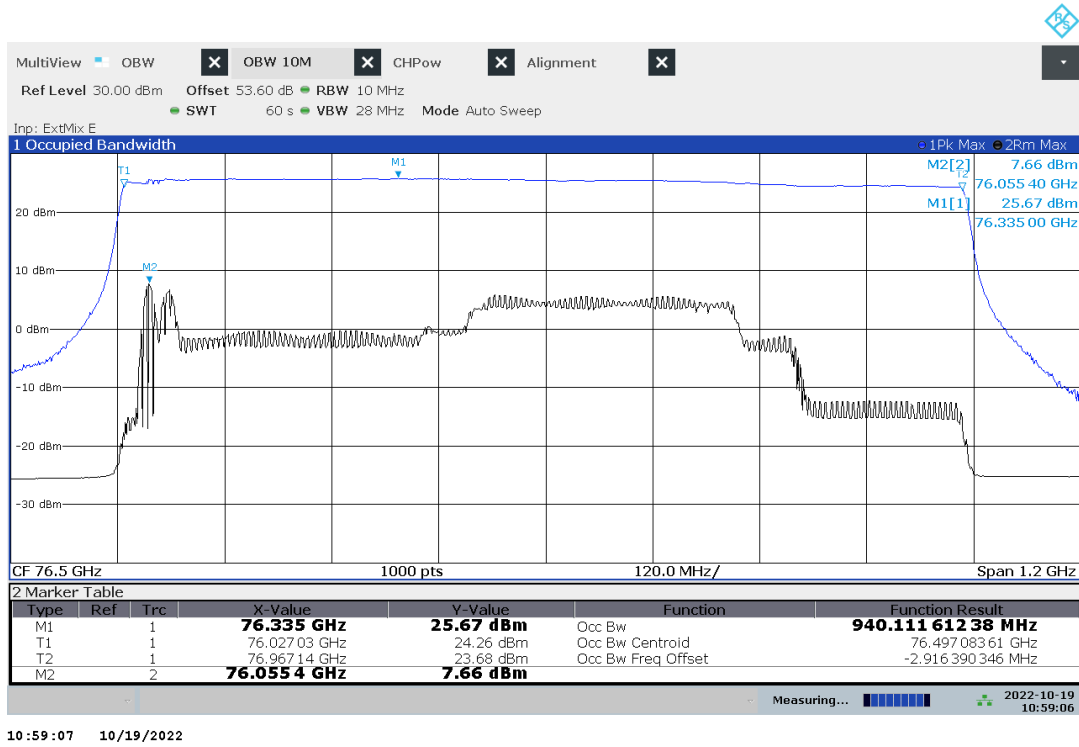

Plot no. 10: OBW, Peak detector, Mode 4



TR no.: 22097768-28470-1

2023-01-24

Plot no. 11: OBW, Peak detector, Mode 5

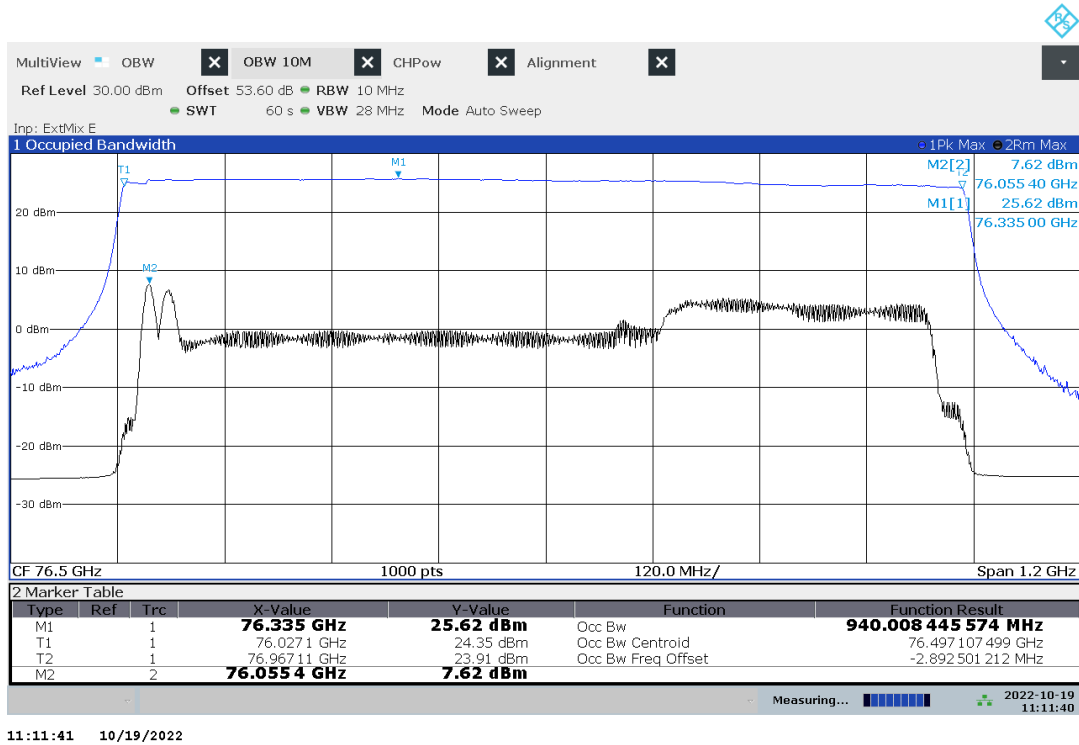

Plot no. 12: OBW, Peak detector, Mode 6

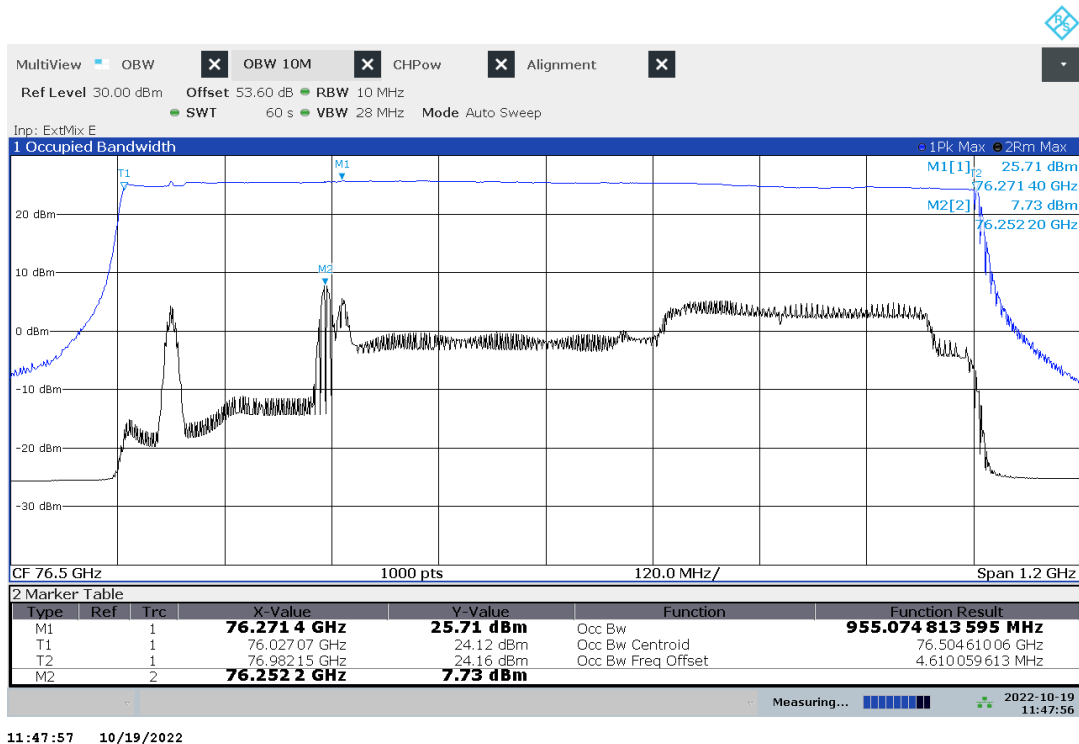

## 7.4 Field strength of spurious radiation (§2.1053 & §95.3379)

### Description

§2.1053 Measurements required: Field strength of spurious radiation.

(a) Measurements shall be made to detect spurious emissions that may be radiated directly from the cabinet, control circuits, power leads, or intermediate circuit elements under normal conditions of installation and operation. Curves or equivalent data shall be supplied showing the magnitude of each harmonic and other spurious emission. For this test, single sideband, independent sideband, and controlled carrier transmitters shall be modulated under the conditions specified in paragraph (c) of §2.1049, as appropriate. For equipment operating on frequencies below 890 MHz, an open field test is normally required, with the measuring instrument antenna located in the far-field at all test frequencies. In the event it is either impractical or impossible to make open field measurements (e.g. a broadcast transmitter installed in a building) measurements will be accepted of the equipment as installed. Such measurements must be accompanied by a description of the site where the measurements were made showing the location of any possible source of reflections which might distort the field strength measurements. Information submitted shall include the relative radiated power of each spurious emission with reference to the rated power output of the transmitter, assuming all emissions are radiated from halfwave dipole antennas.

### Limits

§95.3379 76-81 GHz Band Radar Service unwanted emissions limits.

(a) The power density of any emissions outside the 76-81 GHz band shall consist solely of spurious emissions and shall not exceed the following:

(1) Radiated emissions below 40 GHz shall not exceed the field strength as shown in the following emissions table.

Frequency [MHz]	Field Strength [ $\mu\text{V}/\text{m}$ ] / [dB $\mu\text{V}/\text{m}$ ]	Measurement distance [m]
0.009 – 0.490	2400/F[kHz]	300
0.490 – 1.705	24000/F[kHz]	30
1.705 – 30.0	30.0 / 29.5	30
30 – 88	100 / 40.0	3
88 – 216	150 / 43.5	3
216 – 960	200 / 46.0	3
960 – 40 000	500 / 54.0	3

(2) The power density of radiated emissions outside the 76-81 GHz band above 40.0 GHz shall not exceed the following, based on measurements employing an average detector with a 1 MHz RBW:

Frequency [GHz]	Power Density / EIRP	Measurement distance [m]
40 – 200	600 pW/cm <sup>2</sup> → -1.7 dBm	3
200 – 243	1000 pW/cm <sup>2</sup> → +0.5 dBm	3

### Note

Measurements with the peak detector are also suitable to demonstrate compliance of an EUT, as long as the required resolution bandwidth is used, because peak detection will yield amplitudes equal to or greater than amplitudes measured with RMS detector. The measurement data from a spectrum analyser peak detector will represent the worst-case results (see ANSI C63.26, chapter D2: general considerations).

**Calculation of the far field distance (Rayleigh distance):**

The aperture dimensions of these horn antennas shall be small enough so that the measurement distance in meters is equal to or greater than the Rayleigh distance (i.e.  $R_m = 2D^2 / \lambda$ ), where  $D$  is the largest linear dimension (i.e. width or height) of the antenna aperture in m and  $\lambda$  is the free-space wavelength in meters at the frequency of measurement.

Antenna type	Frequency range [GHz]	D [m]	Highest frequency in use [GHz]	Far field distance $R_m$ [m]
20240-20	18.0 – 26.5	0.0520	26.5	0.478
22240-20	26.5 – 40.0	0.0342	40	0.312
23240-20	33.0 – 50.0	0.0280	50	0.261
24240-20	40.0 – 60.0	0.0230	60	0.212
25240-20	50.0 – 75.0	0.0185	75	0.171
26240-20	60.0 – 90.0	0.0150	90	0.135
27240-20	75.0 – 110	0.0124	110	0.113
28240-20	90.0 – 140	0.0100	140	0.093
29240-20	110 – 170	0.0085	170	0.082
30240-20	140 – 220	0.0068	220	0.068
32240-20	220 – 325	0.00446	243	0.032

**Used test distances**

Up to 18 GHz:	3.00 m
18 – 75 GHz:	0.50 m
75 – 78 GHz:	1.00 m
78 – 110 GHz:	0.50 m
110 – 170 GHz:	0.50 m
In-band / OOB:	1.00 m

**Test setup:** 8.1 – 8.4 (in case of field strength measurements below 40 GHz: test distance correction factor of 20dB/decade is already considered in the plots / test result table)

**Test results**

Channel / Mode	Frequency [GHz]	Detector	Test distance [m]	Level [dB $\mu$ V/dBm]	Limit [dB $\mu$ V/dBm]	Margin [dB]
No critical peaks found. Please refer to plots.						



Plot no. 13: radiated emissions 9 kHz – 30 MHz, loop antenna, mode 0

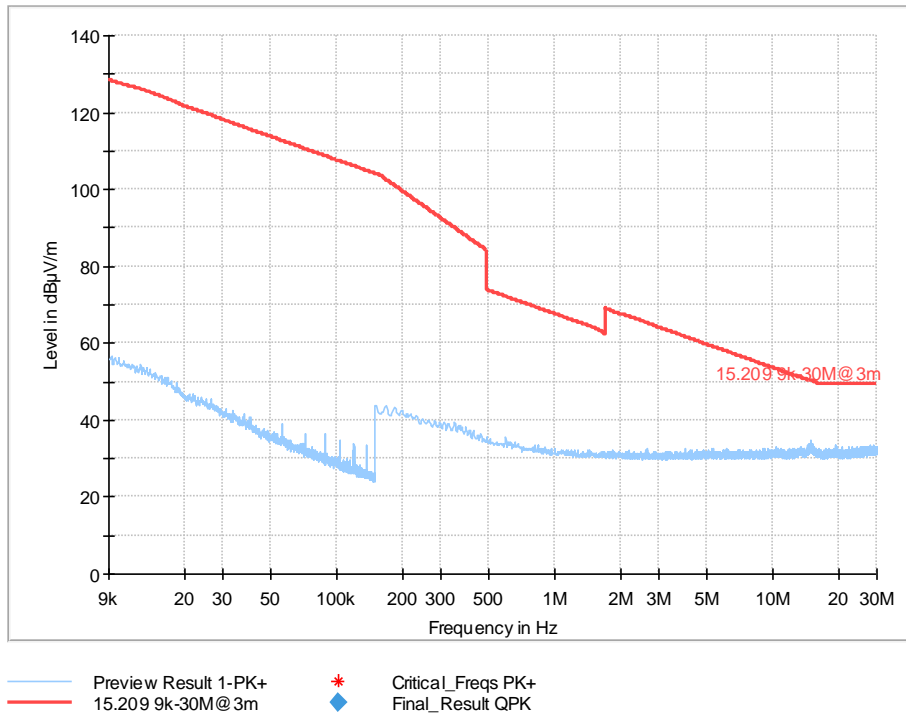

Plot no. 14: radiated emissions 30 MHz – 1 GHz, polarization vertical / horizontal, mode 0

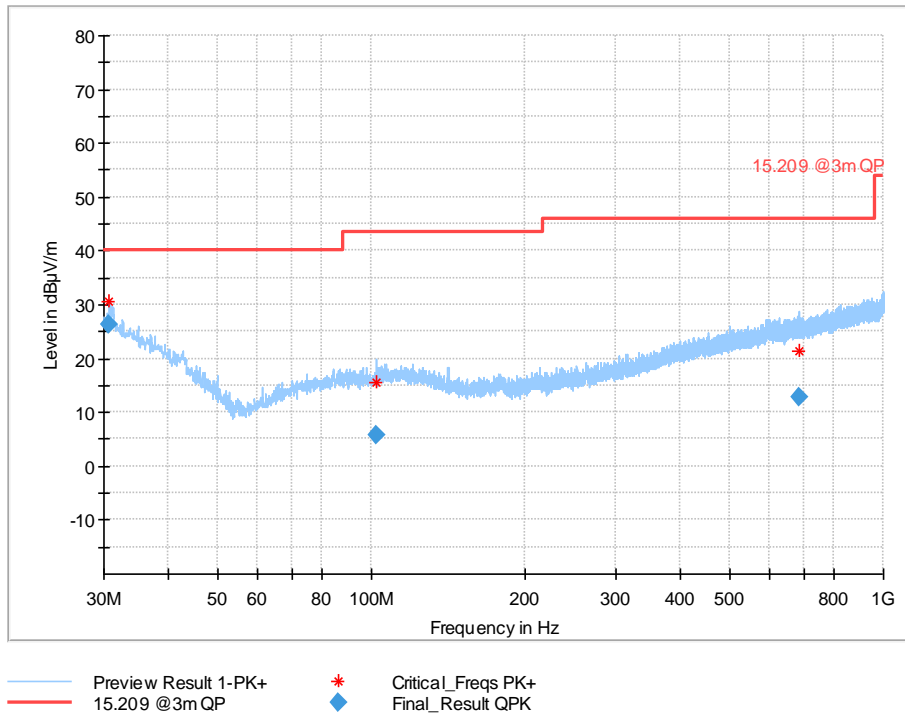

### Final Result

Frequency (MHz)	QuasiPeak (dBµV/m)	Limit (dBµV/m)	Margin (dB)	Meas. Time (ms)	Bandwidth (kHz)	Height (cm)	Pol	Azimuth (deg)
30.773000	26.37	40.00	13.63	100.0	120.000	103.0	V	-20.0
102.335500	5.70	43.50	37.80	100.0	120.000	335.0	H	42.0
686.202000	12.96	46.00	33.04	100.0	120.000	246.0	H	227.0

(continuation of the "Final\_Result" table from column 15 ...)

Frequency (MHz)	Corr. (dB/m)	Comment
30.773000	20.0	-
102.335500	12.3	-
686.202000	20.7	-

Plot no. 15: radiated emissions 1 GHz – 18 GHz, polarization vertical / horizontal, mode 0

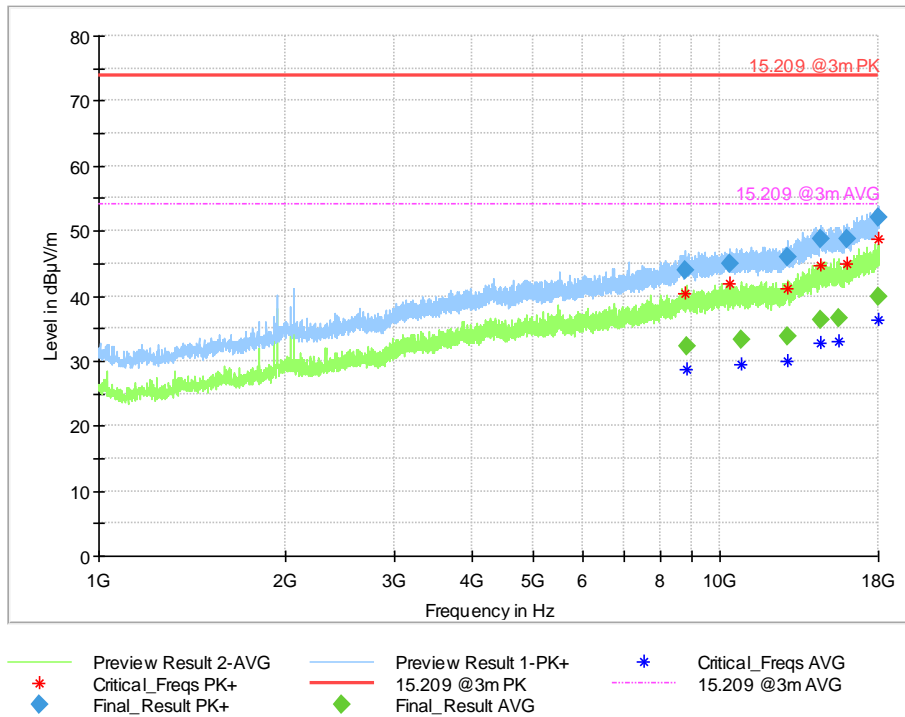

## Final Result

Frequency (MHz)	MaxPeak (dBµV/m)	Average (dBµV/m)	Limit (dBµV/m)	Margin (dB)	Meas. Time (ms)	Bandwidth (kHz)	Height (cm)	Pol
8800.286111	43.96	---	74.00	30.04	100.0	1000.000	150.0	V
8839.938889	---	32.38	54.00	21.62	100.0	1000.000	150.0	V
10370.883333	44.85	---	74.00	29.15	100.0	1000.000	150.0	H
10823.722222	---	33.22	54.00	20.78	100.0	1000.000	150.0	V
12866.480556	---	33.65	54.00	20.35	100.0	1000.000	150.0	H
12872.716667	45.96	---	74.00	28.04	100.0	1000.000	150.0	V
14492.288889	---	36.27	54.00	17.73	100.0	1000.000	150.0	V
14559.000000	48.83	---	74.00	25.17	100.0	1000.000	150.0	V
15518.613889	---	36.58	54.00	17.42	100.0	1000.000	150.0	V
16048.013889	48.72	---	74.00	25.28	100.0	1000.000	150.0	H
17968.444444	---	39.80	54.00	14.20	100.0	1000.000	150.0	V
17974.394444	52.10	---	74.00	21.90	100.0	1000.000	150.0	V

(continuation of the "Final\_Result" table from column 14 ...)

Frequency (MHz)	Azimuth (deg)	Elevation (deg)	Corr. (dB/m)	Comment
8800.286111	148.0	96.0	11.9	-
8839.938889	74.0	70.0	12.1	-
10370.883333	334.0	5.0	15.0	-
10823.722222	132.0	6.0	15.4	-
12866.480556	43.0	25.0	14.9	-
12872.716667	-2.0	62.0	14.9	-
14492.288889	355.0	91.0	17.9	-
14559.000000	259.0	15.0	18.0	-
15518.613889	201.0	101.0	17.8	-
16048.013889	69.0	105.0	17.8	-
17968.444444	209.0	15.0	22.6	-
17974.394444	255.0	6.0	22.6	-

Plot no. 16: radiated emissions 18 GHz – 26.5 GHz, polarization vertical / horizontal, mode 0

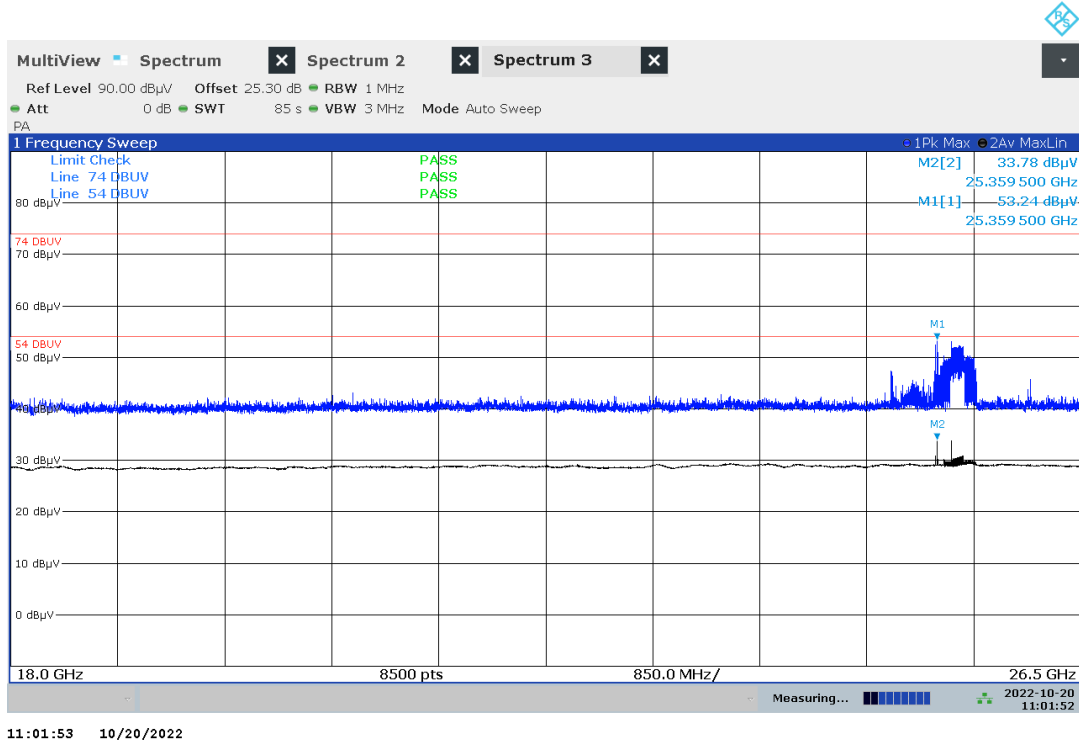

Plot no. 17: radiated emissions 26.5 GHz – 40 GHz, polarization vertical / horizontal, mode 0

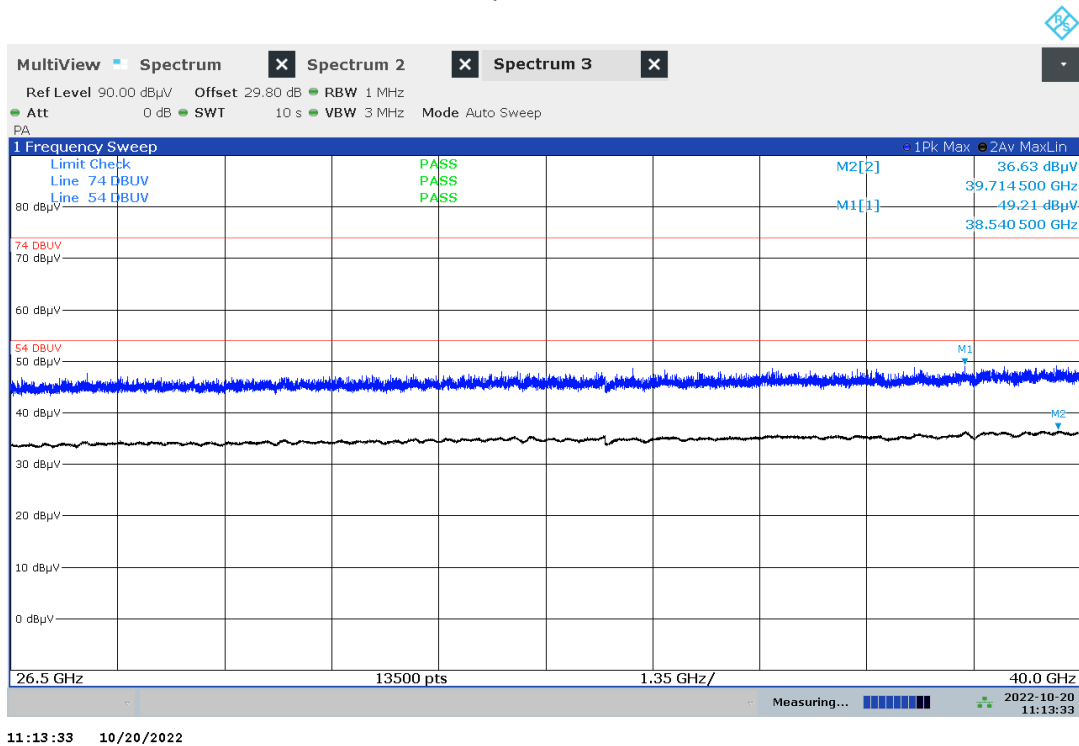

Plot no. 18: radiated emissions 40 GHz – 60 GHz, polarization vertical / horizontal, mode 0

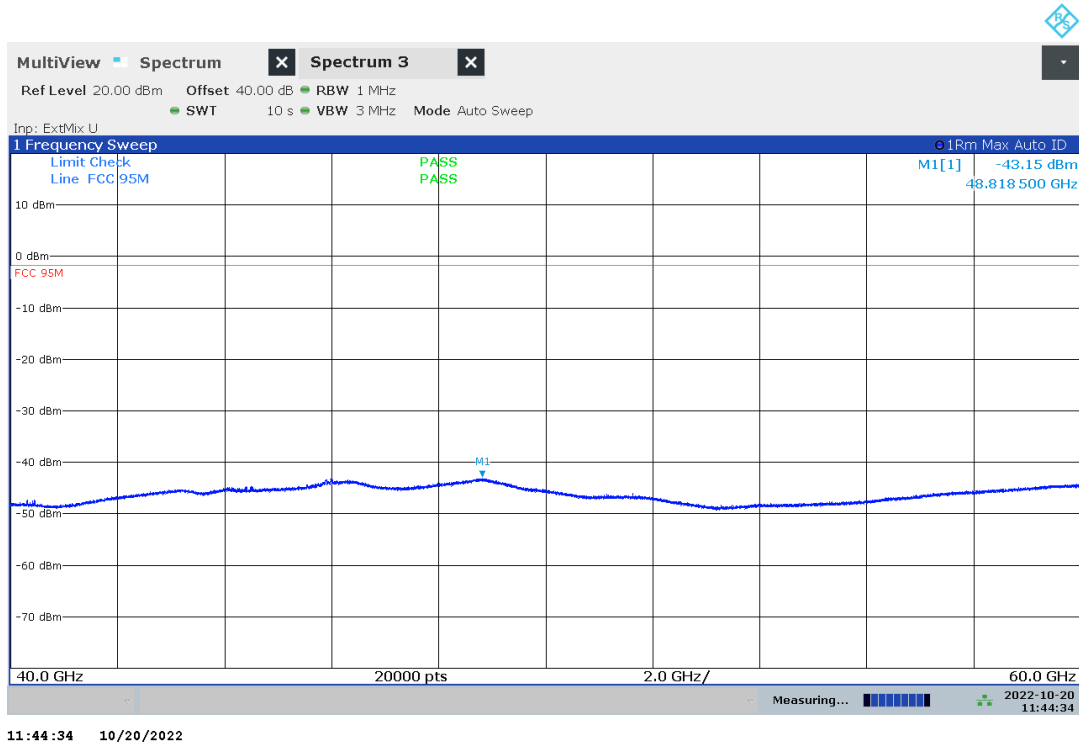

Plot no. 19: radiated emissions 60 GHz – 75 GHz, polarization vertical / horizontal, mode 0

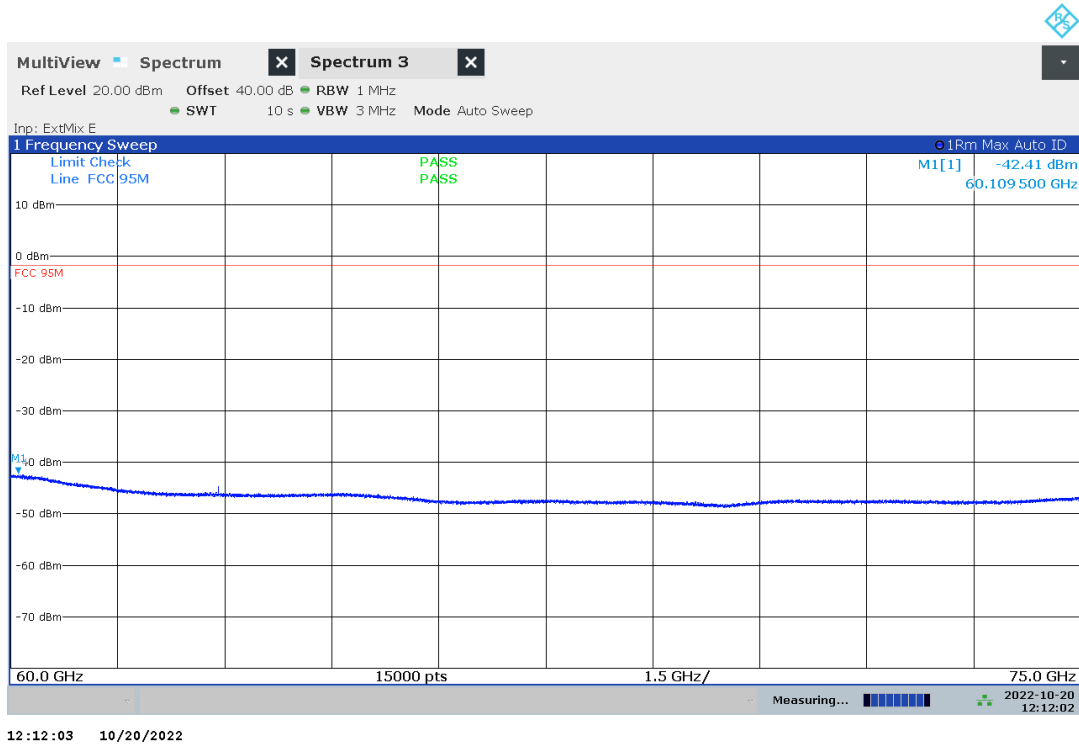

Plot no. 20: radiated emissions 75 GHz – 78 GHz, BEC, polarization aligned with radar sensor, mode 0



Plot no. 21: radiated emissions 78 GHz – 110 GHz, polarization vertical / horizontal, mode 0

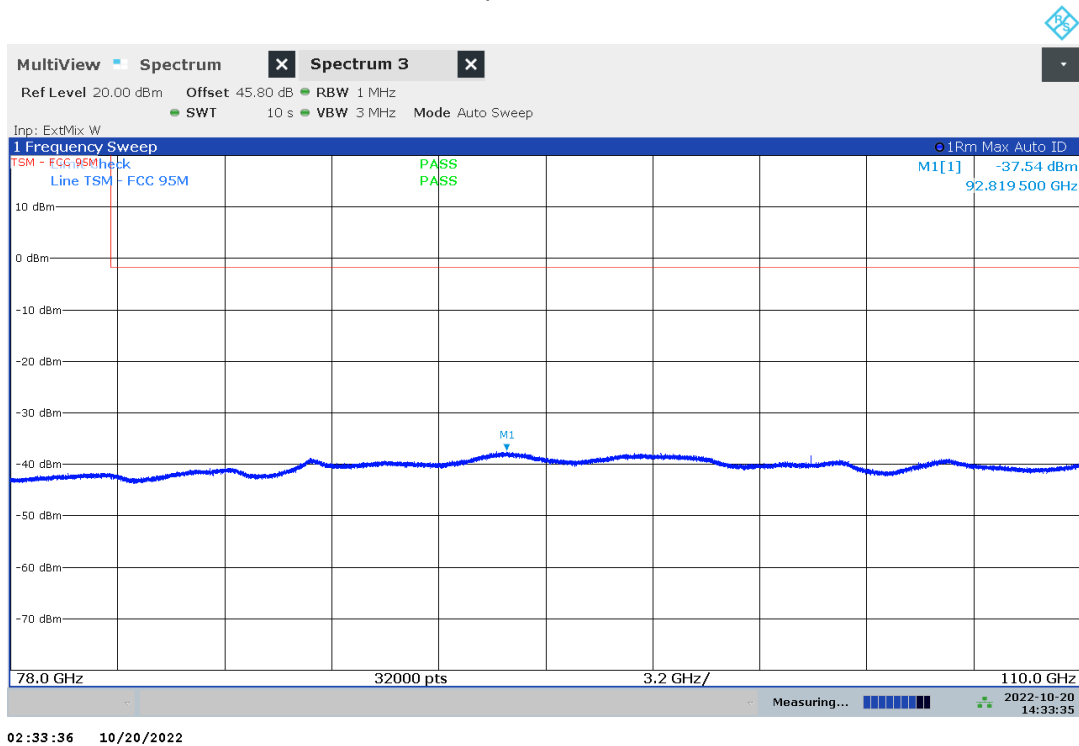

Plot no. 22: radiated emissions 110 GHz – 170 GHz, polarization vertical / horizontal, mode 0

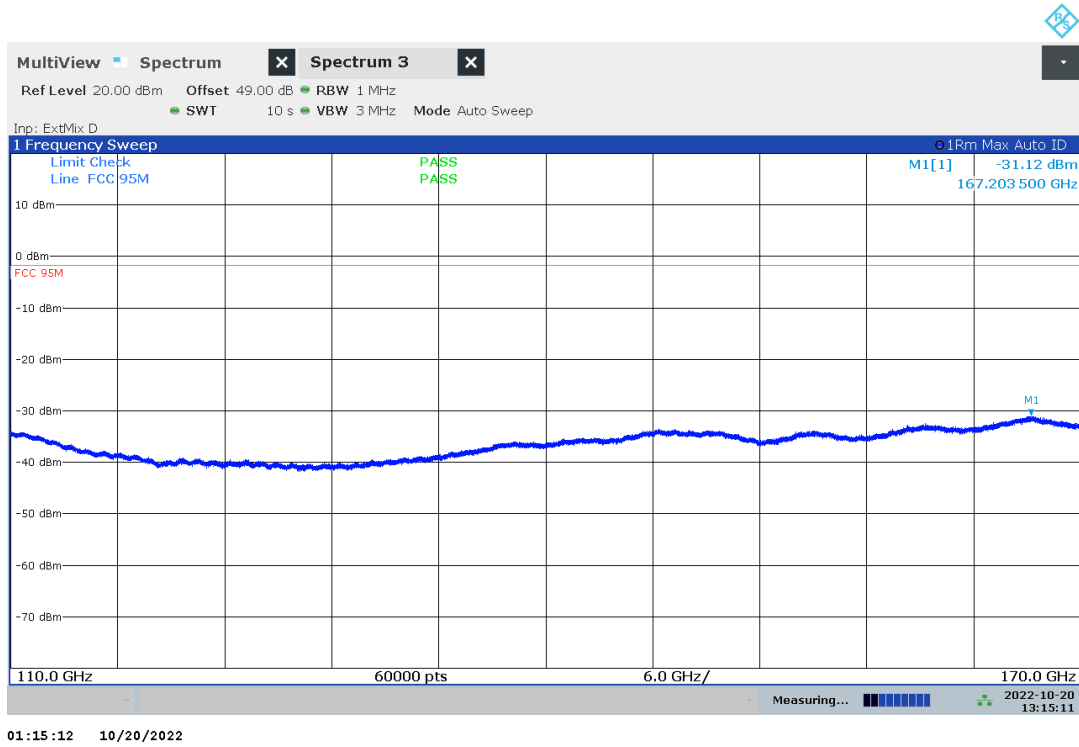

Plot no. 23: radiated emissions 170 GHz – 220 GHz, polarization vertical / horizontal, mode 0

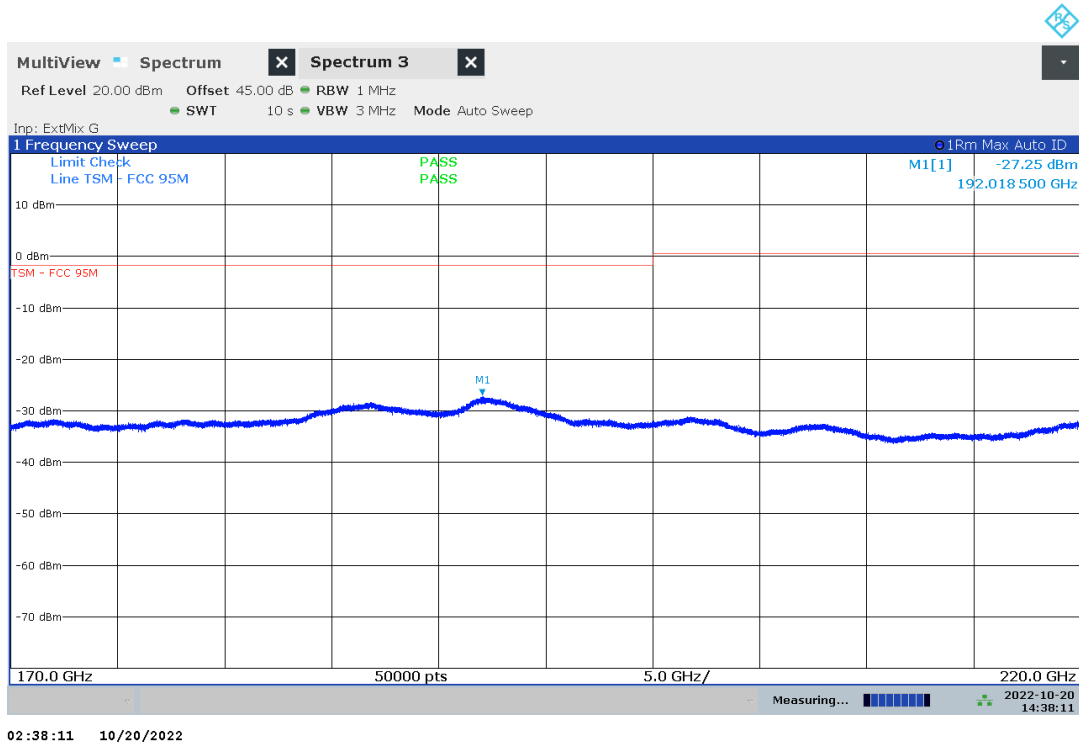

Plot no. 24: radiated emissions 220 GHz – 231 GHz, polarization vertical / horizontal, mode 0

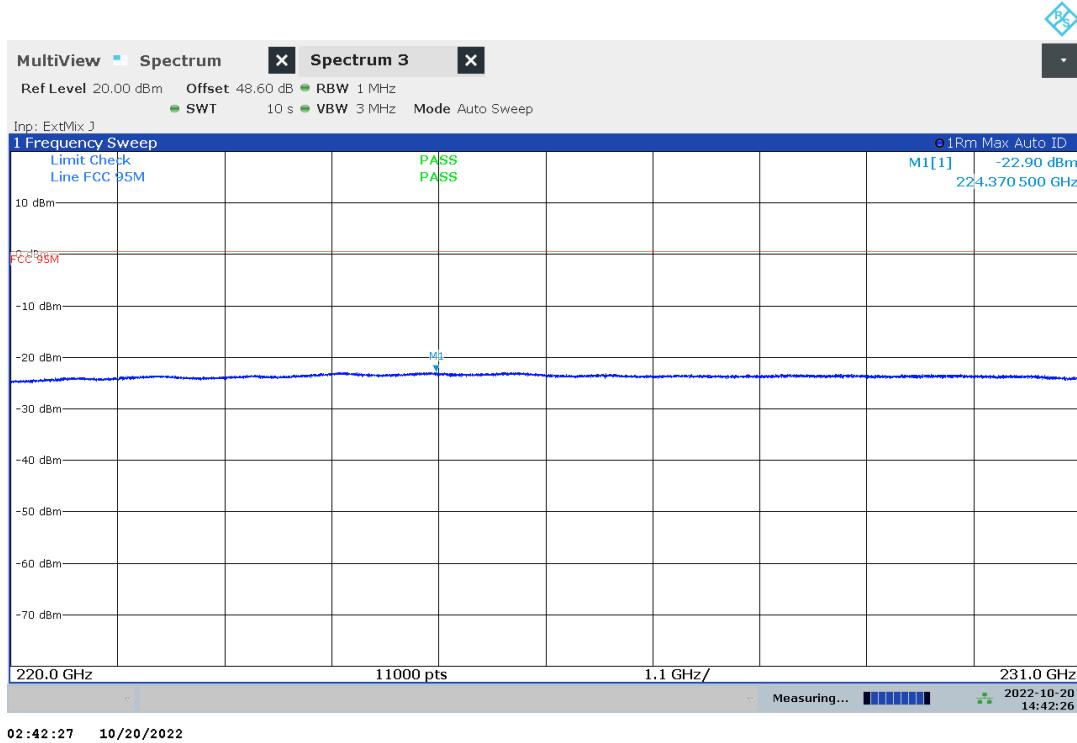



## 8 Test Setup Description

Typically, the calibrations of the test apparatus are commissioned to and performed by an accredited calibration laboratory. The calibration intervals are determined in accordance with the DIN EN ISO/IEC 17025. In addition to the external calibrations, the laboratory executes comparison measurements with other calibrated test systems or effective verifications. Cyclic chamber inspections and range calibrations are performed. Where possible, RF generating and signalling equipment as well as measuring receivers and analysers are connected to an external high-precision 10 MHz reference (GPS-based or rubidium frequency standard).

In order to simplify the identification of the equipment used at some special tests, some items of test equipment and ancillaries can be provided with an identifier or number in the equipment list below (Lab/Item).

### Kind of calibration (abbreviations):

- C = calibrated
- CM = cyclic maintenance
- NR = not required
- L = locked

## 8.1 Semi Anechoic Chamber with Ground Plane

Radiated measurements are performed in vertical and horizontal plane in the frequency range 30 MHz to 1 GHz in a Semi Anechoic Chamber with a metallic ground plane. The EUT is positioned on a non-conductive test table with a height of 0.80 m above the metallic ground plane that covers the whole chamber. The receiving antennas conform to specification ANSI C63.26-2015, American National Standard for Testing Unlicensed Wireless Devices. These antennas can be moved over the height range between 1.0 m and 4.5 m in order to search for maximum field strength emitted from the EUT. The measurement distances between EUT and receiving antennas are indicated in the test setups for the various frequency ranges. For each measurement, the EUT is rotated in all three axes until the maximum field strength is received. The wanted and unwanted emissions are received by a spectrum analyzer where the detector modes and resolution bandwidths over various frequency ranges are set according to requirement ANSI C63.

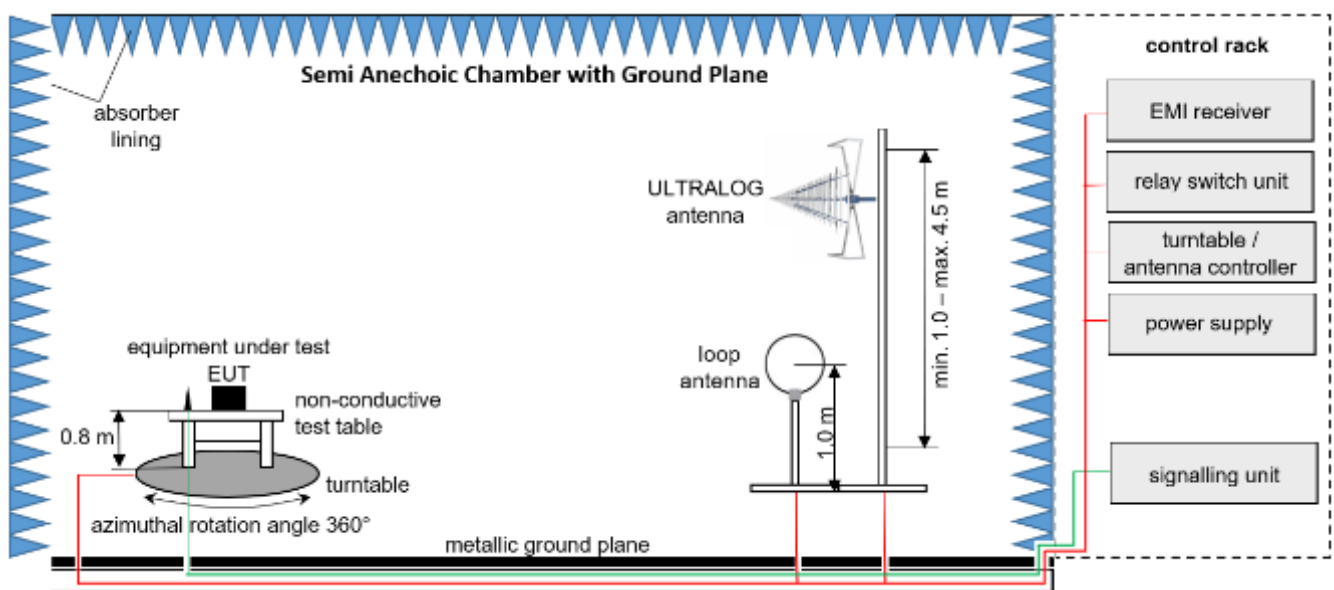

Measurement distance: ULTRALOG antenna at 3 m; loop antenna at 3 m

EMC32 software version: 11.20.00

$$FS = UR + CL + AF$$

(FS-field strength; UR-voltage at the receiver; CL-loss of the cable; AF-antenna factor)

Example calculation:

$$FS [dB\mu V/m] = 12.35 [dB\mu V/m] + 1.90 [dB] + 16.80 [dB/m] = 31.05 [dB\mu V/m] \quad (35.69 \mu V/m)$$

**List of test equipment used:**

No.	Equipment	Manufacturer	Type	Serial No.	IBL No.	Kind of Calibration	Last / Next Calibration
1	Power Supply	Elektro-Automatik GmbH & Co. KG	EA-PSI 9080-40 T	2000230001	LAB000313	NR	–
2	Test table	innco systems GmbH	PT1208-080-RH	-	LAB000306	NR	–
3	Power Supply	Chroma	61604	616040005416	LAB000285	NR	–
4	Positioner	matur GmbH	TD 1.5-10KG		LAB000258	NR	–
5	Compressed Air	Implotex	1-850-30	-	LAB000256	NR	–
6	EMI Test Receiver	Rohde & Schwarz	ESW26	101481	LAB000236	C	2022-07-07 → 12M → 2023-07-07
7	Semi/Fully Anechoic Chamber (SFAC)	Albatross Projects GmbH	Babylon 5 (SAC 5)	20168.PRB	LAB000235	NR	–
8	Measurement Software	Rohde & Schwarz	EMC32 V11.20		LAB000226	NR	–
9	Turntable	matur GmbH	TT2.0-2t	TT2.0-2t/921	LAB000225	NR	–
10	Antenna Mast	matur GmbH	CAM4.0-P	CAM4.0-P/316	LAB000224	NR	–
11	Antenna Mast	matur GmbH	BAM4.5-P	BAM4.5-P/272	LAB000223	NR	–
12	Controller	matur GmbH	FCU 3.0	10082	LAB000222	NR	–
13	Power Supply	Elektro-Automatik GmbH & Co. KG	EA-PS 2042-10 B	2878350292	LAB000191	NR	–
14	Pre-Amplifier	Schwarzbeck Mess-Elektronik OHG	BBV 9718 C	84	LAB000169	NR	–
15	Antenna	Rohde & Schwarz	HF907	102899	LAB000151	C	2020-04-23 → 36M → 2023-04-23
16	Antenna	Rohde & Schwarz	HL562E	102005	LAB000150	C	2020-07-05 → 36M → 2023-07-05
17	Open Switch and Control Platform	Rohde & Schwarz	OSP200 Base Unit 2HU	101748	LAB000149	NR	–
18	Antenna	Rohde & Schwarz	HF907	102898	LAB000124	C	2020-04-23 → 36M → 2023-04-23
19	Antenna	Rohde & Schwarz	HL562E	102001	LAB000123	C	2020-07-05 → 36M → 2023-07-05
20	Antenna	Rohde & Schwarz	HFH2-Z2E - Active Loop Antenna	100954	LAB000108	C	2020-03-25 → 36M → 2023-03-25

## 8.2 Fully Anechoic Chamber

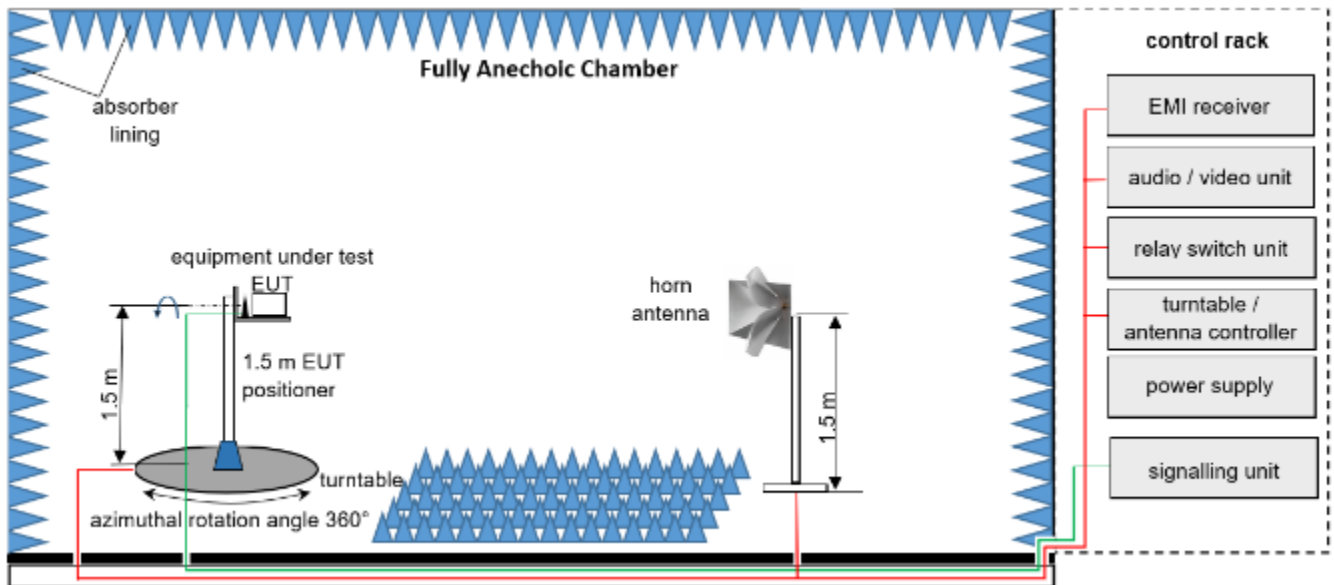

Measurement distance: horn antenna at 3 m  
 EMC32 software version: 11.20.00

$FS = UR + CA + AF$   
 (FS-field strength; UR-voltage at the receiver; CA-loss of the signal path; AF-antenna factor)

Example calculation:

$FS \text{ [dB}\mu\text{V/m]} = 40.0 \text{ [dB}\mu\text{V/m]} + (-35.8) \text{ [dB]} + 32.9 \text{ [dB/m]} = 37.1 \text{ [dB}\mu\text{V/m]} \text{ (} 71.61 \text{ }\mu\text{V/m)}$

**List of test equipment used:**

No.	Equipment	Manufacturer	Type	Serial No.	IBL No.	Kind of Calibration	Last / Next Calibration
1	Power Supply	Elektro-Automatik GmbH & Co. KG	EA-PSI 9080-40 T	2000230001	LAB000313	NR	–
2	Test table	innco systems GmbH	PT1208-080-RH	-	LAB000306	NR	–
3	Power Supply	Chroma	61604	616040005416	LAB000285	NR	–
4	Positioner	maturu GmbH	TD 1.5-10KG		LAB000258	NR	–
5	Compressed Air	Implotex	1-850-30	-	LAB000256	NR	–
6	EMI Test Receiver	Rohde & Schwarz	ESW26	101481	LAB000236	C	2022-07-07 → 12M → 2023-07-07
7	Semi/Fully Anechoic Chamber (SFAC)	Albatross Projects GmbH	Babylon 5 (SAC 5)	20168.PRB	LAB000235	NR	–
8	Measurement Software	Rohde & Schwarz	EMC32 V11.20		LAB000226	NR	–
9	Turntable	maturu GmbH	TT2.0-2t	TT2.0-2t/921	LAB000225	NR	–
10	Antenna Mast	maturu GmbH	CAM4.0-P	CAM4.0-P/316	LAB000224	NR	–
11	Antenna Mast	maturu GmbH	BAM4.5-P	BAM4.5-P/272	LAB000223	NR	–
12	Controller	maturu GmbH	FCU 3.0	10082	LAB000222	NR	–
13	Power Supply	Elektro-Automatik GmbH & Co. KG	EA-PS 2042-10 B	2878350292	LAB000191	NR	–
14	Pre-Amplifier	Schwarzbeck Mess-Elektronik OHG	BBV 9718 C	84	LAB000169	NR	–
15	Antenna	Rohde & Schwarz	HF907	102899	LAB000151	C	2020-04-23 → 36M → 2023-04-23
16	Antenna	Rohde & Schwarz	HL562E	102005	LAB000150	C	2020-07-05 → 36M → 2023-07-05
17	Open Switch and Control Platform	Rohde & Schwarz	OSP200 Base Unit 2HU	101748	LAB000149	NR	–
18	Antenna	Rohde & Schwarz	HF907	102898	LAB000124	C	2020-04-23 → 36M → 2023-04-23
19	Antenna	Rohde & Schwarz	HL562E	102001	LAB000123	C	2020-07-05 → 36M → 2023-07-05
20	Antenna	Rohde & Schwarz	HFH2-Z2E - Active Loop Antenna	100954	LAB000108	C	2020-03-25 → 36M → 2023-03-25

### 8.3 Radiated measurements > 18 GHz

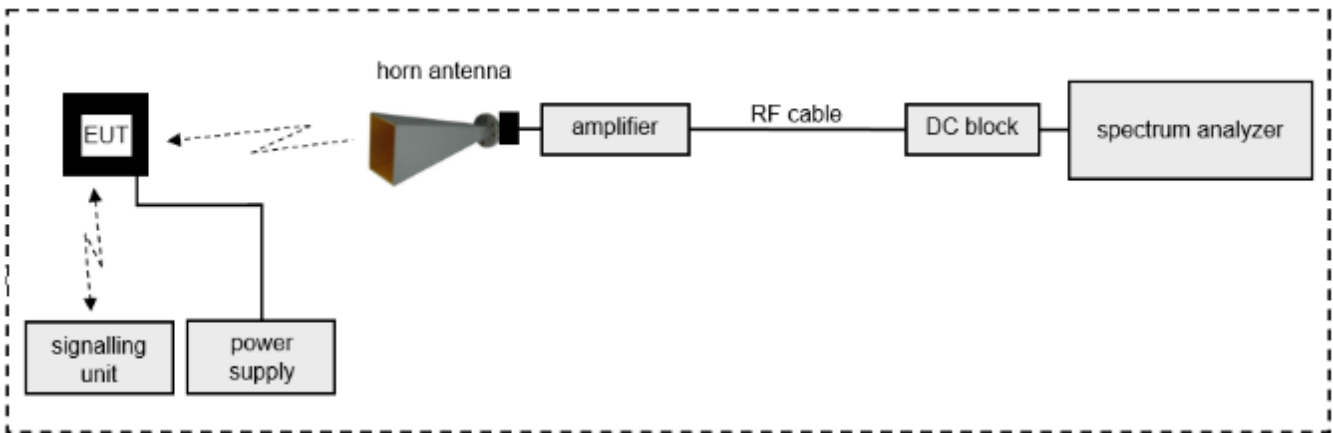

### 8.4 Radiated measurements > 50 GHz

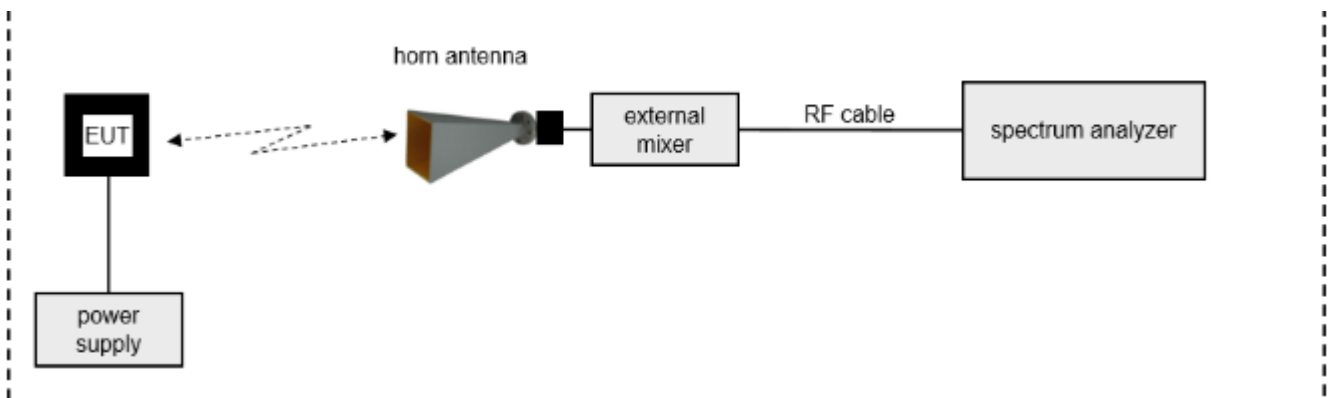

### 8.5 Radiated measurements under extreme conditions

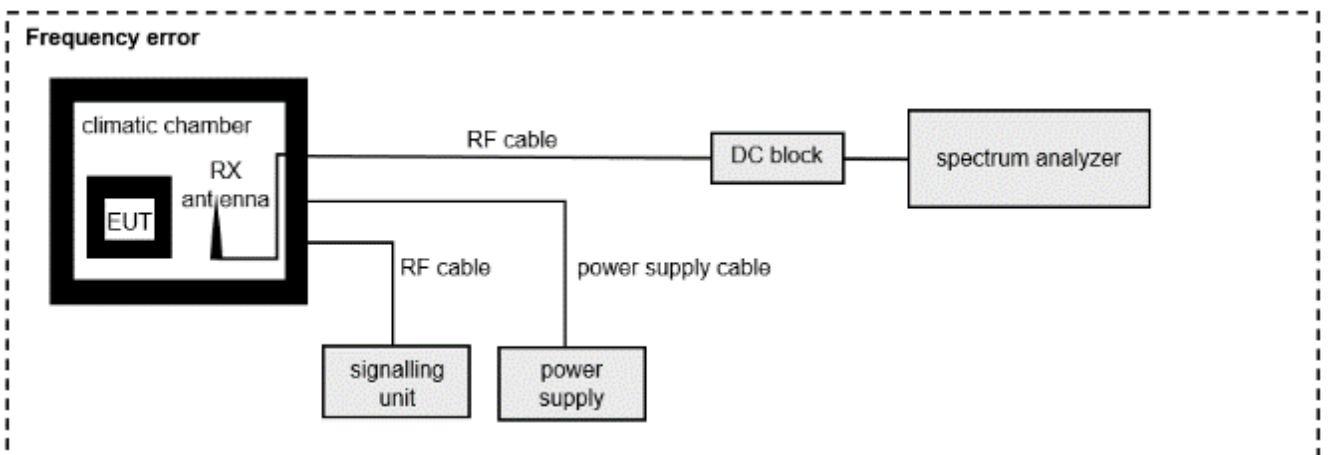

$$\text{ROP} = \text{AV} + \text{D} - \text{G}$$

(ROP-rad. output power; AV-analyzer value; D-free field attenuation of measurement distance; G-antenna gain)

Example calculation:

$$\text{ROP [dBm]} = -54.0 \text{ [dBm]} + 64.0 \text{ [dB]} - 20.0 \text{ [dBi]} = -10 \text{ [dBm]} \text{ (100 } \mu\text{W)}$$

Note: conversion loss of mixer is already included in analyzer value.

**List of test equipment used:**

No.	Equipment	Manufacturer	Type	Serial No.	IBL No.	Kind of Calibration	Last / Next Calibration
1	Test table	innco systems GmbH	PT0707-RH light	–	LAB000303	–	–
2	Spectrum Analyser	Rohde & Schwarz	FSW43	101391	LAB000289	NR	–
3	Power Supply	Elektro-Automatik GmbH & Co. KG	PS 2042-10 B	2878350263	LAB000190	NR	–
4	WG-Coax-Adapter	Flann Microwave Ltd	23373-TF30 UG383/U	273385	LAB000185	CM	2022-09-01 → 12M → 2023-09-01
5	WG-Coax-Adapter	Flann Microwave Ltd	22093-TF30 UG599/U	273263	LAB000183	CM	2022-09-01 → 12M → 2023-09-01
6	WG-Coax-Adapter	Flann Microwave Ltd	20093-TF30 UBR220	273374	LAB000181	CM	2022-09-01 → 12M → 2023-09-01
7	Coaxial Cable	Huber & Suhner	SF101/1.0m	503989/1	LAB000163	CM	2022-05-31 → 12M → 2023-05-31
9	Coaxial Cable	Huber & Suhner	ST18/48"	2276454-01	LAB000157	CM	2022-05-31 → 12M → 2023-05-31
10	Coaxial Cable	Rosenberger	LU7-022-1000	34	LAB000154	NR	–
11	Coaxial Cable	Rosenberger	LU7-022-1000	33	LAB000153	NR	–
12	Antenna	Flann Microwave Ltd	27240-20	273367	LAB000137	CM	2022-09-01 → 12M → 2023-09-01
13	Antenna	Flann Microwave Ltd	25240-20	272860	LAB000133	CM	2022-09-01 → 12M → 2023-09-01
14	Antenna	Flann Microwave Ltd	23240-20	273430	LAB000132	CM	2022-09-01 → 12M → 2023-09-01
15	Antenna	Flann Microwave Ltd	22240-20	270448	LAB000130	C	2020-06-29 → 36M → 2023-06-29
16	Antenna	Flann Microwave Ltd	20240-20	266403	LAB000128	C	2020-06-29 → 36M → 2023-06-29
17	Harmonic Mixer	Rohde & Schwarz	FS-Z110	102000	LAB000114	C	2022-04-14 → 12M → 2023-04-14
18	Harmonic Mixer	Rohde & Schwarz	FS-Z75	102015	LAB000112	C	2022-04-20 → 12M → 2023-04-20
19	Harmonic Mixer	Rohde & Schwarz	FS-Z140	101144	LAB000115	C	2022-03-28 → 12M → 2023-03-28
20	Harmonic Mixer	Rohde & Schwarz	FS-Z090	102020	LAB000113	C	2022-04-05 → 12M → 2023-04-05
21	Spectrum Analyser	Rohde & Schwarz	FSW50	101450	LAB000111	C	2022-07-28 → 12M → 2023-07-28
22	Antenna Mast	Schwarzbeck Mess-Elektronik OHG	AM 9104	99	LAB000109	NR	–

## 9 Measurement procedures

### 9.1 Radiated spurious emissions from 9 kHz to 30 MHz

#### Test setup

- The EUT is set up according to its intended use, as described in the user manual or as defined by the manufacturer.
- In case of floor standing equipment, it is placed in the middle of the turn table.  
In case of tabletop equipment it is placed on a non-conductive table with a height of 80 cm.
- Additional equipment, cables, ... necessary for testing, are positioned like under normal operation.
- Interface cables, e.g. power supply, network, ... are connected to the connection box in the turn table.
- EUT is powered on and set into operation.

#### Pre-scan

- Turntable performs an azimuthal rotation from 0° to 315° in 45° steps.
- For each turntable step the EMI-receiver/spectrum analyser performs a positive-peak/max-hold sweep (=worst-case). Data is transferred to EMI-software and recorded. EMI-software will show the maximum level of all single sweeps as the final result for the pre-scan.

#### Final measurement

- Significant emissions found during the pre-scan will be maximized by the EMI-software by rotating the turntable from 0° to 360°.
- Loop antenna is rotated with special 3D adapter set to find maximum level of emissions.
- Plot of the pre-scan with frequencies of identified emissions including levels, correction factors, turn table position and settings of measuring equipment is recorded.

#### Distance correction (extrapolation)

- When performing measurements on test distances other than defined in the rules, the results shall be extrapolated to the specified distance by conservatively presuming that the field strength decays at 40 dB/decade of distance in the region closer than  $\lambda$  in m divided by  $2\pi$  (i.e.,  $\lambda/2\pi$ ), and at 20 dB/decade of distance beyond that, using the measurement of a single point at the radial angle that produces the maximum emission.

This correction is already included in the limit line of corresponding measurement plots.

Detailed requirements can be found in e.g. ANSI C63.4 / C63.26



## 9.2 Radiated spurious emissions from 30 MHz to 1 GHz

### Test setup

- The EUT is set up according to its intended use, as described in the user manual or as defined by the manufacturer.
- In case of floor standing equipment, it is placed in the middle of the turn table.  
In case of tabletop equipment it is placed on a non-conductive table with a height of 80 cm.
- Additional equipment, cables, ... necessary for testing, are positioned like under normal operation.
- Interface cables, e.g. power supply, network, ... are connected to the connection box in the turn table.
- EUT is powered on and set into operation.

### Pre-scan

- Turntable performs an azimuthal rotation from 0° to 315° in 45° steps.
- Antenna polarisation is changed (H-V / V-H) and antenna height is changed from 1 meter to 4 meters.
- For each turntable step / antenna polarisation / antenna height the EMI-receiver/spectrum analyser performs a positive-peak/max-hold sweep (=worst-case). Data is transferred to EMI-software and recorded. EMI-software will show the maximum level of all single sweeps as the final result for the pre-scan.

### Final measurement

- Significant emissions found during the pre-scan will be maximized by the EMI-software based on evaluated data during the pre-scan by rotating the turntable and changing antenna height and polarisation.
- Final measurement will be performed with measuring equipment settings as defined in the applicable test standards (e.g. ANSI C6.4).
- Plot of the pre-scan with frequencies of identified emissions including levels, correction factors, turn table position, antenna polarisation and settings of measuring equipment is recorded.

### Distance correction (extrapolation)

- When performing measurements on test distances other than defined in the rules, the results shall be extrapolated to the specified distance by conservatively presuming that the field strength decays at 20 dB/decade of distance beyond the region  $\lambda$  in m divided by  $2\pi$  (i.e.,  $\lambda/2\pi$ ), using the measurement of a single point at the radial angle that produces the maximum emission.  
This correction is already included in the corresponding measurement plots.

Detailed requirements can be found in e.g. ANSI C63.4 / C63.26

### 9.3 Radiated spurious emissions from 1 GHz to 18 GHz

#### Test setup

- The EUT is set up according to its intended use, as described in the user manual or as defined by the manufacturer.
- In case of floor standing equipment, it is placed in the middle of the turn table.  
In case of tabletop equipment it is placed on a non-conductive table with a height of 80 cm.
- Additional equipment, cables, ... necessary for testing, are positioned like under normal operation.
- Interface cables, e.g. power supply, network, ... are connected to the connection box in the turn table.
- EUT is powered on and set into operation.

#### Pre-scan

- Turntable performs an azimuthal rotation from 0° to 315° in 45° steps.
- Antenna polarisation is changed (H-V / V-H) and antenna height is changed from 1 meter to 4 meters.
- For each turntable step / antenna polarisation / antenna height the EMI-receiver/spectrum analyser performs a positive-peak/max-hold sweep (=worst-case). Data is transferred to EMI-software and recorded. EMI-software will show the maximum level of all single sweeps as the final result for the pre-scan.

#### Final measurement

- Significant emissions found during the pre-scan will be maximized by the EMI-software based on evaluated data during the pre-scan by rotating the turntable and changing antenna height and polarisation.
- Final measurement will be performed with measuring equipment settings as defined in the applicable test standards (e.g. ANSI C6.4).
- Plot of the pre-scan with frequencies of identified emissions including levels, correction factors, turn table position, antenna polarisation and settings of measuring equipment is recorded.

#### Distance correction (extrapolation)

- When performing measurements on test distances other than defined in the rules, the results shall be extrapolated to the specified distance by conservatively presuming that the field strength decays at 20 dB/decade of distance beyond the region  $\lambda$  in m divided by  $2\pi$  (i.e.,  $\lambda/2\pi$ ), using the measurement of a single point at the radial angle that produces the maximum emission.  
This correction is already included in the corresponding measurement plots.

Detailed requirements can be found in e.g. ANSI C63.4 / C63.26

## 9.4 Radiated spurious emissions above 18 GHz

### Test setup

- The EUT is set up according to its intended use, as described in the user manual or as defined by the manufacturer.
- Additional equipment, cables, ... necessary for testing, are positioned like under normal operation.
- EUT is powered on and set into operation.
- Test distance depends on EUT size and test antenna size (farfield conditions shall be met).

### Pre-scan

- The test antenna is handheld and moved carefully over the EUT to cover the EUT's whole sphere and for different polarizations of the antenna.

### Final measurement

- Significant emissions found during the pre-scan will be maximized, i.e. position and antenna orientation causing the highest emissions with Peak and RMS detector
- Final measurement will be performed with measuring equipment settings as defined in the applicable test standards (e.g. ANSI C63.4 / C63.26).
- Final plot showing measurement data, levels, frequency, measuring time, bandwidth, correction factor, margin to the limit and limit is recorded.

### Note

- In case of measurements with external harmonic mixers (e.g. above 50 GHz) special care is taken to avoid possible overloading of the external mixer's input.
- As external harmonic mixers may generate false images, care is taken to ensure that any emission measured by the spectrum analyzer is indeed radiated from the EUT and not internally generated by the external harmonic mixer. Signal identification feature of spectrum analyzer is used to eliminate/reduce images of the external harmonic mixer.

### Distance correction (extrapolation)

- When performing measurements on test distances other than defined in the rules, the results shall be extrapolated to the specified distance by conservatively presuming that the field strength decays at 20 dB/decade of distance beyond the region  $\lambda$  in m divided by  $2\pi$  (i.e.,  $\lambda/2\pi$ ), using the measurement of a single point at the radial angle that produces the maximum emission.  
This correction is already included in the corresponding measurement plots.

Detailed requirements can be found in e.g. ANSI C63.4 / C63.26

## 10 MEASUREMENT UNCERTAINTIES

Radio frequency	$\leq \pm 10$ ppm
Radiated emission	$\leq \pm 6$ dB
Temperature	$\leq \pm 1$ °C
Humidity	$\leq \pm 5$ %
DC and low frequency voltages	$\leq \pm 3$ %

The indicated expanded measurement uncertainty corresponds to the standard measurement uncertainty for the measurement results multiplied by the coverage factor  $k = 2$ . It was determined in accordance with EA-4/01 m:2013. The true value is located in the corresponding interval with a probability of 95 %.

---

**End of Test Report**

---