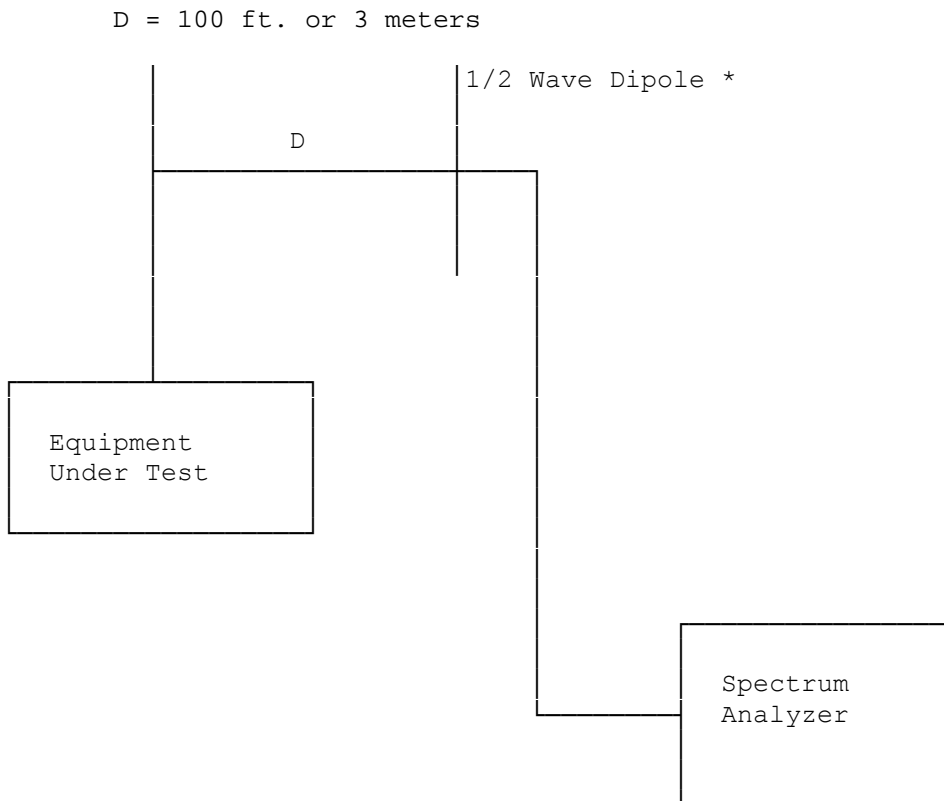

Exhibit 7. Test Set-Up Procedures

BLOCK DIAGRAM #1

Transmitter Radiated Spurious Emissions Test Set Up



See Equipment List for Equipment Specifications

- * 1/2 Wave Dipole 30-1000 MHz
Dual Ridged Guide Antenna or Broadband Log Periodic 1-10 GHz

TEST EQUIPMENT LIST A**SPECTRUM TECHNOLOGY, INC.**

<u>Equipment</u>	<u>Manufacturer</u>	<u>Serial Number</u>	<u>Cal Date/Due Date</u>	
Spectrum Analyzer	Hewlett-Packard 8562A	08562-60062	11/15/00	11/15/01
Amplifier 9 kHz-1300 MHz	Hewlett-Packard 8447F OPT H64	2727A02208	11/15/00	11/15/01
Service Monitor	IFR FM/AM 500A	4103	---	---
Oscilloscope	Kikusui C055060	6132295	---	---
Power Supply	Astron VS35	8601266	---	---
Voltmeter	Fluke 8020A	N2420658	---	---
Multimeter	Fluke 25	3710310	---	---
Wattmeter	Bird 43	56227	---	---
RF Termination	Bird 8135	10004	---	---
Dual Phase LISN 50 ohm/50 uH	STI per MP-4	02	1/10/01	1/10/02
Dual Phase LISN 50 ohm/50 uH	Compliance Design	8012-50R-24-BNC	1/10/01	1/10/02
Audio Generator	Hewlett-Packard 205-AG	8689	---	---
Thermometer	Fluke 52	3965185	---	---
Test Line	Simulator, Teltone TLS-2	none	---	---
Turn Table, RC	EMCO 1060-2M	8912-1415	---	---
Antenna Mast, RC	Compliance Design, Inc.	M100	---	---
Antennas:				
Dipole Set	EMCO Model: 3121C	1335		reference only
Dipole Set	EMCO Model: 3121C	1336		reference only
Bi-Conical	EMCO 3104	3763		reference only
Bi-Conical	EMCO 3104C	9401-4635	01/25/01	1/25/02
Log-Periodic	EMCO 3146	1754	01/25/01	1/25/02
BiConiLog	EMCO 3141	1125	04/28/00	4/28/01
Active Loop	EMCO 6502	9107-2645		reference only

Rev. 01/01

Photos of EUT at OATS facility follow:

