

SMARTIRE HIGH PRESSURE TIRE MONITORING SYSTEM INSTALLATION INSTRUCTIONS

710.0016 13-Mar-04



SmarTire Systems Inc.
Suite 150, 13151 Vanier Place
Richmond, British Columbia
Canada, V6V 2J1
Tel: 1.604.276.9884
Fax: 1.604.276.0864
Email: info@smartire.com
www.smartire.com

SmarTire Europe Limited
Park 34
Didcot, Oxfordshire
United Kingdom, OX11 7WB
Tel: +44.1235.511010
Fax: +44.1235.514640
Email: info@smartire.co.uk
www.smartire.com

Dealer Stamp

FCC NOTICE

This device complies with Part 15 of the FCC Rules. Operation is subject to the following two conditions: (1) this device may not cause harmful interference, and (2) this device must accept any interference received, including interference that may cause undesired operation. This equipment has been tested and found to comply with the limits for a Class B digital device, pursuant to Part 15 of the FCC Rules. These limits are designed to provide reasonable protection against harmful interference in a residential installation. This equipment generates, uses and can radiate radio frequency energy and, if not installed and used in accordance with the instructions, may cause harmful interference to radio communications. However, there is no guarantee that interference will not occur in a particular installation. If this equipment does cause harmful interference to radio or television reception, which can be determined by turning the equipment off and on, the user is encouraged to try to correct the interference by one or more of the following measures: • Reorient or relocate the receiving antenna. • Increase the separation between the equipment and receiver. • Connect the equipment into an outlet on a circuit different from that to which the receiver is connected. • Consult the dealer or an experienced radio/TV technician for help. Changes or modifications to this device without the express approval of SmarTire Systems Inc. may void the user's authority to use this device.

Technical Specifications

	Receiver	Transmitter
Input Supply	10 -18 vDC	
Power Consumption	Normal = 480 mW, Max = 1.90 W	
Weight	454 g, (16.0 oz)	40 g (1.4 oz)
Dimensions	102 x 117 x 38 mm (4.0 x 4.6 x 1.5 in.)	71 x 33 x 16 mm (2.8 x 1.3 x .63 in.)
Operating Temperature	-40 °C to 85 °C (-40 °F x 185 °F)	-40 °C to 125 °C (-40 °F x 257 °F)
Pressure Accuracy		+/- 4.35 PSI (0.3 BAR)
Maximum Cold Inflation Pressure		160 PSI (11.03 Bar)
Maximum Operating Pressure		188 PSI (13.0 Bar)
Battery Life		5 years at 48,000 km/yr (30,000 miles/yr) - approx.

Parts

QTY	Part number	Description	QTY	Part number	Description
1	200.0087	Receiver, Shielded	1	101.1060	Antenna Kit, 60'
1	200.0068	Full Function Display (FFD)	1	101.1040	Antenna Kit, 40'
4	200.0101	Transmitter - Strap Ts-2	1	101.1020	Antenna Kit, 20'
4	264.0115	Strap - Stainless Steel Clamp			
1	260.0157	FFD Cable			
1	260.0158	Power Cable			Note: Antennas purchased as required

Factory Default Pressure Settings

The default pressure settings can be customized to suit the application as required. Use the Full Function Display and follow the SmarTire FFD Manual carefully to change the default settings if required.

Cold Inflation Pressure	125 PSI
Low Pressure Warning	110 PSI
Pressure Deviation Alert	10 PSI
High Temperature Warning	195° F

Warnings

This tire monitoring system does not in any way replace the need for regular maintenance of the tire pressures and tire conditions.

System Installation and Usage

Use of the SmarTire® system requires that it has been properly installed and programmed by qualified personnel according to SmarTire Systems Inc. documentation. This includes the Owner's Manual and any supplementary installation instructions included with system components.

Use of Chemicals

Temporary resealing or reinflation products containing internal sealers or propellants in any tire/wheel assembly may adversely affect the operation of the Sensor/Transmitters.

Reacting to Alerts

When an alert or warning condition is detected, reduce vehicle speed to an appropriate safe level and proceed to a safe stopping location or facility where the tire can be inspected and serviced. The low pressure alert or warning indicates that the air pressure has dropped to a selected minimum.

Installation of Transmitters

1. Slide the stainless steel straps through each of the Transmitters.
2. Dismount tire from wheel.
3. Position strap/Transmitter assembly around wheel at the lowest point of the drop-center. See Figures 1 and 2.
4. The strap transmitter is to be positioned 3" from the worm gear
5. Position the Transmitter at the valve stem opening then pull strap tight. Push in on the worm gear nut to hold the position.
6. Tighten with 5/16" nut driver or screwdriver until Transmitter is secure (35" pounds torque).
7. Cut excess strap leaving 1" past the worm gear.
8. Mount tire being careful not to pinch the Transmitter with the bead of the tire.
9. Balance the tire.
10. Mount the tire on the vehicle.

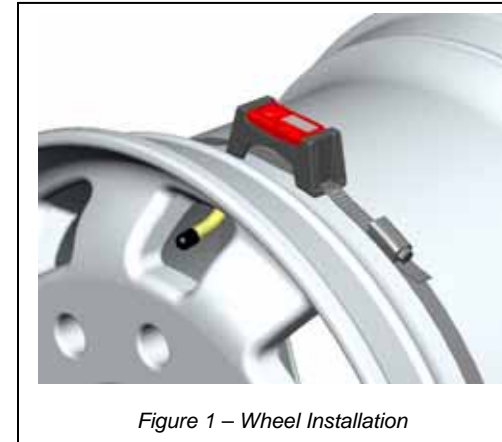

Figure 1 – Wheel Installation

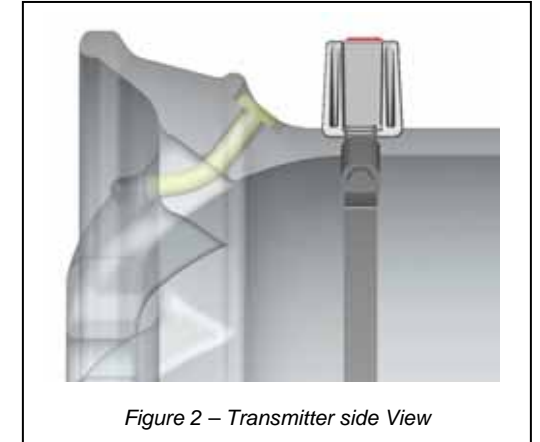

Figure 2 – Transmitter side View

Installation of Receiver and Full Function Display

1. Install the antenna according to instructions in the antenna kit.
2. Find a suitable location for the Receiver and Full Function Display assembly. The Receiver is normally installed behind the dashboard. The Full Function Display is assembled somewhere on or in the dashboard.
3. Wire the system as shown in Figure 5. Plug the Full Function Display into the left plug of the Receiver. Plug the power cable into right side plug.
4. The red wire of the power cable connects to a positive fused connection. The black wire connects to ground.

Note: All connections must be made with the vehicle battery isolated

Testing the System

1. Turn on the ignition switch and verify that the Receiver beeps three times and the FFD turns on.
2. Reduce the air in a tire to 3 PSI below the alert level (15 PSI or 1.03 BAR), and verify that the warning light of the FFD turns on.
3. Re-inflate the tire.
4. Repeat steps 2 and 3 for remaining tire positions.
5. In cases where the settings are not appropriate to the installation, use the FFD manual to program the system to the desired settings.

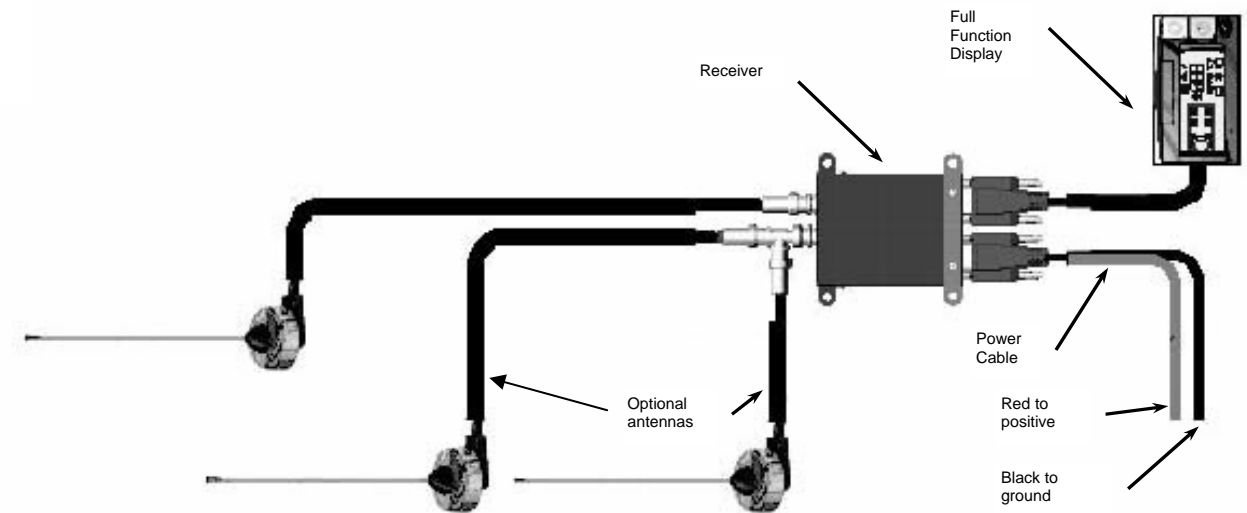

Figure 5 – System wiring