



SCANTER 5502/5602 Radar Systems

Technical & Maintenance Manual

© Terma, Denmark, 2019. Proprietary and intellectual rights of Terma A/S and/or its subsidiaries are involved in the subject-matter of this material and all manufacturing, reproduction, use, disclosure, and sales rights pertaining to such subject-matter are expressly reserved. This material is submitted for a specific purpose as agreed in writing, and the recipient by accepting this material agrees that this material will not be used, copied, or reproduced in whole or in part nor its contents (or any part thereof) revealed in any manner or to any third party, except own staff, to meet the purpose for which it was submitted and subject to the terms of the written agreement.

This document is released for use only if signed by relevant staff or stamped "EDM Release Controlled".

CM:



2019-10-10

605502-HT Rev. C2

Record of changes

Description	Rev	Date
Released.	A	2013-01-18
General update. Removed "ASPECT" chapter.	B	2013-05-28
Index and back updated.	B1	2013-08-22
Added SCANTER 5602. Updated functional description. Updated PSAT calibration procedure. Updated transceiver setup and adjustments. Added ACS-880 motor controller. Added hazardous material information and SW license acknowledgement. Added workaround in connection with corrective maintenance of redundant systems.	C	2016-07-06
Added FCC and ISED/ISDE warning statements. Updated tasks 4 + 5 (replacing External I/O and Interconnection Board).	C1	2019-09-06
Updated section "Microwave Radiation Safety Margins / Marges de sécurité du rayonnement micro-ondes".	C2	2019-10-09



(Intentionally left blank)

1	INTRODUCTION	11
1.1	Purpose and scope	11
1.2	Long-term storage of power supply units	11
1.3	Warnings and safety instructions	12
	1.3.1 Microwave radiation safety margins / Marges de sécurité du rayonnement micro-ondes	13
	1.3.2 FCC Warning Statements	15
	1.3.2.1 FCC Part 15.19(3)	15
	1.3.2.2 FCC Part 15.21	15
	1.3.2.3 FCC Part 15.105(b)	15
	1.3.3 ISED Warning Statements / Déclarations d'avertissement d'ISDE	16
	1.3.3.1 ISED RSS-Gen, Sec 6.8/ ISDE CNR-Gen, Sec 6.8	16
	1.3.3.2 ISED RSS-Gen, Sec 8.4 / CNR-Gen ISDE, Sec 8.4	17
1.4	Restrictions on use of Radio Transmitter	17
	1.4.1 Hazardous material information	17
	1.4.1.1 RoHS compliance	17
	1.4.1.2 Dangerous goods category or HAZCHEM coded materials	17
	1.4.1.3 Specific substance(s) information	17
	1.4.1.4 Other substance(s) information	18
1.5	Technical terms and definitions	18
1.6	Abbreviations and acronyms	22
1.7	Referenced documentation	24
2	SCANTER 5502/5602 Radar Systems	27
2.1	Configurations	28
2.2	Single transceiver system configuration	28
2.3	Redundant transceiver system configuration	29
	2.3.1 Redundant transceiver operation	30
2.4	SCANTER 5502/5602 product technology and features	31
	2.4.1 Doppler-based processing (SCANTER 5602 only)	33
	2.4.2 Physical appearance of SCANTER 5502/5602	34
3	Functional Description	37
3.1	Software-defined functionality	38
3.2	Solid State Power Amplifier (SSPA)	38
	3.2.1 SSPA graceful degradation	39
3.3	Frequency diversity and time diversity	40
3.4	Full coherency	41
3.5	Pulse compression	42
3.6	Power sector transmission	44
3.7	Sub-clutter visibility and Doppler-based processing (SCANTER 5602 only)	44
3.8	Video processing	46
3.9	Static clutter map and blanking	47



3.10	Environment adaptation	48
3.11	Controlling and using the radar	48
3.11.1	Local and remote control	48
3.11.2	Profiles	48
3.11.3	Built-in Test Equipment (BITE)	48
3.11.3.1	BITE - errors/warnings	49
3.11.3.2	BITE status	50
3.11.3.3	BITE measurements	50
3.11.3.4	BITE logging	51
4	Hardware modules	53
4.1	Transceiver building blocks	53
4.2	Dimensions	53
4.2.1	Transceiver block schematic	55
4.2.2	Part numbers, modules	55
4.3	Hardware structure	56
4.3.1	Internal cabling	56
4.4	Modules	57
4.4.1	Solid State Power Amplifier (SSPA)	57
4.4.1.1	SSPA description	57
4.4.1.2	Reliability	60
4.4.2	Waveguide Assy	60
4.4.3	RxTx	62
4.4.4	RxTx Controller	63
4.4.5	Blower Assy	66
4.4.6	Crate Assy incl. Motherboard	66
4.4.7	PC Controller Board	69
4.4.8	Common Platform 4 (CP4) Board	69
4.4.9	Power Supply Unit (PSU)	70
4.4.9.1	Connections	71
4.4.9.2	Block Schematic, Supplies	71
4.4.9.3	Block Schematic, SPI and I2C buses	73
4.4.9.4	Operator's Panel	74
4.4.10	External I/O Board	74
4.4.10.1	Connections	74
4.4.10.2	X1-X4, COM 1-4	75
4.4.10.3	X7, WG Switch	76
4.4.10.4	X8, Motor Communication, COM 0	77
4.4.10.5	X9, Waveguide Switch and Encoder	78
4.4.10.7	X12-X14, LAN 1-3.	81
4.4.10.8	X15-X16, Tx Inhibit / EMCON	82
4.4.10.9	X17, Aux. I/O	83
4.4.10.10	X18-X19, Analogue Video Output 1-2	84

4.4.10.11	X21-X22, Digital Video and Azimuth Output 1-2	84
4.4.10.12	X23-X24, Azimuth Output 1-2	85
4.4.10.13	X25-X28, Trigger Output 1-4	87
4.4.11	Antenna Control Unit (ACU)	87
4.4.11.1	ACU variants	88
4.4.11.2	ACU in installation (simplified)	88
4.4.11.3	Setup of motor controller	88
4.4.11.4	Dimensions, internal wiring, etc.	88
5	Radar Service Tool	89
5.1	Installation	89
5.1.1	System requirements	89
5.1.2	Installing and starting the Radar Service Tool	89
5.2	RST features	89
5.2.1	Authentication	89
5.2.2	Access levels	89
5.2.3	User documentation	90
5.2.4	Parameters and BITE access	90
5.2.5	Tools	90
5.2.6	Situation display	90
5.3	RST screen layout	90
5.3.1	RST keyboard and mouse actions	92
5.3.2	General	92
5.3.3	Adjust text size	93
5.3.4	Situation perspective control	93
5.3.5	RST menu navigation and search	94
5.4	Preferences	95
5.5	Perspectives	95
6	Safety loops / Enabling ACU	99
6.1	Single System	99
6.1.1	Safety loop	99
6.1.2	Warnings from antenna system	100
6.1.3	Enabling ACU	101
6.2	Redundant system	101
6.2.1	Safety loop	101
6.2.2	Warnings from antenna system	102
6.2.3	Enabling ACU	102
6.2.3.1	RxTx A on / RxTx B off	103
6.2.3.2	RxTx A off / RxTx B on	104
6.2.3.3	RxTx A on / RxTx B on	104
7	Maintenance	107



7.1	Preventive maintenance	107
7.1.1	General preventive maintenance	107
7.1.2	Scheduled preventive maintenance	107
7.2	Corrective maintenance	108
7.2.1	ACU with type selector switch	108
7.2.2	ACU without type selector switch	108
7.3	Consumables, spare parts and tools	112
7.3.1	Consumables	112
7.3.1.1	Terma on-site consumables	113
7.3.2	Spare Parts	113
7.3.3	Tools	113
7.3.3.1	Standard Tools	114
7.3.3.2	Terma Tool Kit	114
7.3.4	Cable Marking	116
7.4	Corrective maintenance tasks	118
7.4.1	Task 1: Replace Filters, Transceiver	119
7.4.2	Task 2: Replace Fuse, Mains	120
7.4.3	Task 4: Replace External I/O (A14)	121
7.4.4	Task 5: Replace Interconnection Board (A15)	124
7.4.5	Task 6: Replace PSU (A6)	127
7.4.6	Task 7: Replace Common Platform 4 (A9-A12)	129
7.4.7	Task 8: Replace PC Controller Board (A8)	131
7.4.8	Task 9: Replace Crate Assy (A7)	133
7.4.9	Task 10: Replace Blower Assy (A5)	137
7.4.10	Task 11: Replace RxTx Control (A4)	138
7.4.11	Task 12: Replace RxTx (A3)	141
7.4.12	Task 13: Replace Waveguide Assy (A1)	144
7.4.13	Task 14: Replace SSPA (A2)	146
7.4.14	Task 15: Replace Waveguide, SSPA	148
7.4.15	Task 16: Replace Filter, ACU	149
7.4.16	Task 17: Replace Battery, PC Controller Board (A8)	150
7.4.17	Task 19: Replace Blower Assy, CP4	151
8	Transceiver setup and adjustments	153
8.1	Setting up transceiver redundancy (redundant systems only)	153
8.2	Transceiver redundancy test (redundant systems only)	154
8.3	Radar control	155
8.3.1	Start transceiver - single	156
8.3.2	Stop transceiver - single	157
8.3.3	Start transceivers - redundant	157
8.3.4	How to activate a transceiver (redundant systems only)	158
8.4	Create sectors	158
8.5	Entering HW module information	159



8.6	Backup/Restore	160
8.6.1	Create/Restore backup of configuration data	160
8.7	Antenna correction and range adjustment	162
8.8	Antenna squint calibration	163
8.9	PSAT calibration	164
9	BITE errors and warnings	167
10	List of installation documents	187
11	Annex A - Acknowledgement	189



1 INTRODUCTION

1.1 Purpose and scope

The purpose of this manual is to provide an overview of the SCANTER 5502/5602 Radar Systems. The document includes a functional description of the radar system as well as information on main transceiver hardware components.

In addition, the document serves as a guidance for technical staff in connection with fault isolation and maintenance of the 5502/5602 transceiver. The manual provides the necessary tasks for the preventive and corrective maintenance of the transceiver, including the tools, equipment and re-alignment procedures for the maintenance tasks.

1.2 Long-term storage of power supply units

SCANTER radar electronics must generally be stored and transported under the following conditions:

Packed for transportation and storage - environmental requirements		
Temperature	-40°C to 70°C	IEC 60068-2-1 / 60068-2-2
Humidity	93±3%RH @ 40°	IEC 60068-2-30
IP protection class	Keep dry	-

Two spare part units contain individual power supplies, that require reconditioning during long term(>3 years). These units are:

Terma part no.	Name
386251-xxx	SSPA, Power Supply
386290-xxx	PSU

Due to the use of electrolytic capacitors, the units must be powered for some hours every 3 years in order not to degrade performance and risk damaging the unit when put into use after long-term storage.

It is recommended to mount a power supply spare part in the appropriate radar system and run it for some hours at least every 3 years. This way you ensure that you have a working and healthy spare part.



1.3 Warnings and safety instructions







The figure below outlines basic warnings and safety instructions. For further information and details, refer to doc. no. 970637-HT: “Warnings and Safety Instructions for Terma Radar Antenna Systems”.

WARNING
WARNINGS,
CAUTIONS AND
SAFETY
INSTRUCTIONS

**SAFETY
FIRST**

CAUTION
AUTHORIZED
PERSONNEL
ONLY

WARNING **ACCESSING THE ANTENNA INSTALLATION** **CAUTION**







     

Only access for authorized personnel.

Always use the safety switch to stop transmission and the rotating antenna, before accessing the antenna platform. A rotating antenna may cause injury or even death.

Always wear climbing harness when accessing a radar tower. Observe and follow local safety regulations. Inform the relevant people of the work to be performed.

WARNING **MAINTENANCE OF THE RADAR SYSTEM** **CAUTION**

Never stand in front of an open-ended waveguide or coax from which power may be radiated. The transceiver produces non-ionising electromagnetic radiation. On a non-faulty system, only the antenna radiates. Radiation could be dangerous for the human body and precautions should be taken.

High voltage may be present at several points of the equipment, even with equipment switched off. Observe and follow all electrical safety precautions. These voltages may cause injury or even death.

Antenna, transceiver, computers and instruments must be connected to the same electrical protective ground.

Always use ESD (Electrostatic Sensitive Device) precautionary procedures when handling ESD marked modules. The equipment contains components sensitive to damage by electrostatic discharge. Wrist strap connected to earth bonding point must always be used when handling unshielded electronics. Modules must be stored in static shielding packaging (EIA-541). Module repair must be done on a ESD workstation, by qualified personnel.

Use only non-magnetic tools when working with magnetrons.

In no event, Terma A/S shall be held liable for any direct, indirect, punitive, incidental or consequential damages whatsoever arising out of or connected with the use or misuse of its products.

Radar safety sheet - 970637-0A

Fig. 1.1 Warnings and safety instructions

1.3.1 Microwave radiation safety margins / Marges de sécurité du rayonnement micro-ondes

ENGLISH:

The guidelines¹ for exposure to electromagnetic fields recommend an average permissible power density exposure limit of 10 W/m² at the calculated safety distances summarized below.

Two limits are defined; one for occupational exposure and one for exposure to the general public:

Exposure characteristics	Power density [W/m ²]	Power density [dBm/cm ²]
Occupational (controlled exposure)	50	7
General population (uncontrolled exposure)	10	0

Compliance with the power density exposure limits is documented per Terma document 924000-RC: "Power Density in Proximity to SCANTER Antennas with SCANTER 4000/5000/6000 Series Transceivers".

The safety distances are summarized as follows:

- For all combinations of SCANTER 5000/6000 Series transceivers and SCANTER antennas, the safety limits are met at all distances from the radar antenna rotation center of 5 meters in the horizontal plane and/or more than 1 meter above or below the antenna center in the vertical plane.
- For vertical distances of more than 5 meters below the antenna and/or more than 65 meters range, the power density is at least 10 times below the limit for exposure to the general public.
- For vertical distances of more than 30 meters below the antenna, the power density is at least 100 times below the limit for exposure to the general public for all combinations of transceivers and antennas.

Note: Microwave power is not emitted from any parts of the SCANTER radar systems, but from the antenna.

1. As defined by the following regulatory standards:

- a. ICNIRP Guidelines for limiting exposure to time-varying electric, magnetic and electromagnetic fields, Health Physics, 74 (4), pp. 494-522, 1998.
- b. FCC CFR: Title 47, Part 1.1310.
- c. ISED RSS-102, Sec 4.



FRANCAIS:

Les lignes directrices¹ pour l'exposition aux champs électromagnétiques recommandent une limite d'exposition moyenne admissible de la densité de puissance de 10 W/m² aux distances de sécurité calculées résumées ci-dessous.

Deux limites sont définies; une pour l'exposition professionnelle et l'autre pour l'exposition au grand public:

Caractéristiques d'exposition	Densité de puissance [W/m ²]	Densité de puissance [dBm/cm ²]
Professionnelle (exposition contrôlée)	50	7
Grand public (exposition non-contrôlée)	10	0

Conformité aux limites d'exposition à la densité de puissance est documentée dans le document Terma 924000-RC: "Power Density in Proximity to SCANTER Antennas with SCANTER 4000/5000/6000 Series Transceivers".

Les distances de sécurité se résument comme suit:

- Pour toutes les combinaisons d'émetteurs-récepteurs SCANTER Séries 5000/6000 et d'antennes radar SCANTER, les limites de sécurité se conforment à toutes les distances du centre de rotation de l'antenne de 5 mètres dans le plan horizontal et/ou de plus de 1 mètre au-dessus ou au-dessous du centre de l'antenne dans le plan vertical.
- Pour les distances verticales de plus de 5 mètres au-dessous de l'antenne et/ou de plus de 65 mètres de distance horizontale, la densité de puissance est au moins 10 fois inférieure à la limite d'exposition au grand public.
- Pour les distances verticales de plus de 30 mètres au-dessous de l'antenne, la densité de puissance est au moins 100 fois inférieure à la limite d'exposition du grand public pour toutes les combinaisons d'émetteurs-récepteurs et d'antennes.

Note: Le rayonnement micro-ondes n'est émise par aucune partie des systèmes radar SCANTER que par l'antenne.

1. Comme définies par les normes législatives suivantes:

- a. ICNIRP Guidelines for limiting exposure to time-varying electric, magnetic and electromagnetic fields, Health Physics, 74 (4), pp. 494-522, 1998.
- b. FCC CFR: Title 47, Part 1.1310.
- c. ISED RSS-102, Sec 4.

1.3.2 FCC Warning Statements

IMPORTANT:

The content of this section applies to installations in the United States only.

1.3.2.1 FCC Part 15.19(3)

This device complies with Part 15 of the FCC Rules. Operation is subject to the following two conditions: (1) This device may not cause harmful interference, and (2) this device must accept any interference received, including interference that may cause undesired operation.

1.3.2.2 FCC Part 15.21

CAUTION: Changes or modifications not expressly approved by the party responsible for compliance could void the user's authority to operate the equipment.

1.3.2.3 FCC Part 15.105(b)

NOTE: This equipment has been tested and found to comply with the limits for a Class B digital device, pursuant to Part 15 of the FCC Rules. These limits are designed to provide reasonable protection against harmful interference in a residential installation. This equipment generates, uses and can radiate radio frequency energy and, if not installed and used in accordance with the instructions, may cause harmful interference to radio communications. However, there is no guarantee that interference will not occur in a particular installation. If this equipment does cause harmful interference to radio or television reception, which can be determined by turning the equipment off and on, the user is encouraged to try to correct the interference by one or more of the following measures:

- Reorient or relocate the receiving antenna.
- Increase the separation between the equipment and receiver.
- Connect the equipment into an outlet on a circuit different from that to which the receiver is connected.
- Consult the dealer or an experienced radio/TV technician for help.



1.3.3 ISED Warning Statements / Déclarations d'avertissement d'ISDE

IMPORTANT:

The content of this section applies to installations in Canada only.

Le contenu de cette section s'applique uniquement aux installations au Canada.

1.3.3.1 ISED RSS-Gen, Sec 6.8/ ISDE CNR-Gen, Sec 6.8

ENGLISH:

This radio transmitter - IC: 2628A-SC5000 - has been approved by Innovation, Science and Economic Development Canada to operate with the antenna types listed below, with the maximum permissible gain indicated. Antenna types not included in this list that have a gain greater than the maximum gain indicated for any type listed are strictly prohibited for use with this device.

Antenna type	High Gain (HG)
Length	21'
Max. gain @ antenna flange	≥ 38 dBi
Polarization	Horizontal or circular

FRANCAIS:

Le présent émetteur radio - IC: 2628A-SC5000 - a été approuvé par Innovation, Sciences et Développement économique Canada pour fonctionner avec les types d'antenne énumérés ci-dessous, avec le gain maximal admissible indiqué. Les types d'antenne non inclus dans cette liste et dont le gain est supérieur au gain maximal indiqué pour l'un des types énumérés, sont strictement interdits pour l'exploitation de l'émetteur.

Type d'antenne	High Gain (HG)
Longueur	21'
Gain maximal à la bride d'antenne	≥ 38 dBi
Polarisation	Horizontale ou circulaire

1.3.3.2 ISED RSS-Gen, Sec 8.4 / CNR-Gen ISDE, Sec 8.4

ENGLISH:

This device contains licence-exempt transmitter(s)/receiver(s) that comply with Innovation, Science and Economic Development Canada's licence-exempt RSS(s). Operation is subject to the following two conditions:

1. This device may not cause interference.
2. This device must accept any interference, including interference that may cause undesired operation of the device.

FRANCAIS:

Le présent appareil contient un ou plusieurs émetteurs/recepteurs conformes aux CNR d'Innovation, Sciences et Développement économique Canada applicables aux appareils radio exempts de licence. L'exploitation est autorisée aux deux conditions suivantes:

1. L'appareil ne doit pas produire de brouillage.
2. L'utilisateur de l'appareil doit accepter tout brouillage subi, même si le brouillage est susceptible d'en compromettre le fonctionnement.

1.4 Restrictions on use of Radio Transmitter

The following should be noted:

Restrictions on putting into service and/or requirements for authorization exist for all member states of the European Union.

The radar shall be configured in accordance with local frequency allocation, and authorization for transmission shall be obtained from relevant national authority.

1.4.1 Hazardous material information

1.4.1.1 RoHS compliance

The SCANTER 5502/5602 Transceiver is RoHS compliant, but contains a few components, which are EXEMPT from RoHS compliance until June 2016. These components will be replaced by RoHS-compliant parts before the end of the exemption period.

1.4.1.2 Dangerous goods category or HAZCHEM coded materials

The SCANTER 5502/5602 Transceiver does not contain materials regulated as dangerous goods or HAZCHEM.

1.4.1.3 Specific substance(s) information

The SCANTER 5502/5602 transceiver subsystem does not contain any specific substances.



1.4.1.4 Other substance(s) information

None of the prohibited substances in Annex XIV of EU Regulation (EC) 1907/2006 REACH are present in the SCANTER 5502/5602 Transceiver subsystem in concentrations above the minimum contained in the legislation.

Two NTC resistors in the SCANTER 5502/5602 Transceiver subsystem, each weighing 8 mg, contain lead monoxide in a concentration above the minimum on the latest SVHC Candidate List. There is no exposure risk during transport, installation, operation or servicing.

1.5 Technical terms and definitions

Accuracy	The difference between the average of repeated measurements of the same quantity under identical conditions and the known "true" value, i.e. the difference between the average of the measurements of the range to a fixed reference target and the range value calculated from the geographical coordinates of the reference target and radar sensor.
Antenna	The upper rotating part of the antenna system. The antenna is radiating the RF power and receiving the echoes from the targets. Depending on the antenna type the radiating component can be a slotted waveguide or a horn with belonging reflector.
Antenna System	System consisting of antenna, motor and gear for antenna rotation and, if present, stabilized platform (motors and gears to compensate for roll and pitch on a ship).
Azimuth	The angle between a horizontal reference direction (north or heading) and the horizontal projection of the direction of interest, measured clockwise.
Diplexer	A 3-port device with 1 input and 2 outputs, or 2 inputs and 1 output, all ports with waveguide flanges. The diplexer includes two band pass filters enabling the diplexer to split a two-frequency input signal into two separate signals. The diplexer is often used in Frequency Diversity systems.
Doppler Effect	In radar technology the Doppler Effect is used for speed measurement, among others. The Doppler Effect is the apparent change in frequency or pitch when a moving target is hit by a radar beam. When a target is approaching the radar, the target is "compressing" the beam in front of it resulting in a higher frequency in the echo.

Double Cancellation	<p>A circuit consisting of two cascaded Single Delay Line Cancellers. The frequency response of the Double cancellation circuit improves the filters ability to eliminate DC components of fixed targets and clutter.</p>
Encoder	<p>Unit which provides information about the azimuth i.e. the direction in which the antenna is pointing. For each rotation the encoder sends a number of azimuth count pulses (ACP's), typically 8192 pulses and one azimuth reference pulse (ARP).</p> <p>The encoder is included in a encoder assembly which normally holds one or two encoders.</p>
Extractor	<p>The extractor analyses the incoming video for plot creating plots. Furthermore, it calculates plot properties such as area, intensity, centre of gravity etc.</p>
Frequency Diversity	<p>Frequency Diversity (FD) is a sequential transmission on two different frequencies which after processing increases the signal quality by an increase of the signal-to-noise ratio. The target is hit twice and behaves differently depending upon the frequency of the electromagnetic wave hitting it. Furthermore, if slotted waveguide antennas are used, an additional advantage is achieved, namely the time diversity.</p>
Lack	<p>Lack is a number counting unsuccessful consecutive updates of a track.</p>
Log Compression	<p>In this process, the signal is converted from a 26 bit floating point signal into an 8-bit logarithmic signal.</p>
Mixer	<p>A function of the mixer is to convert frequencies, either up or down. The ideal mixer performs the mathematical multiplication of two input signals. It creates signal components positioned at frequencies equal to the sum and difference of the input signals.</p> <p>For ideal performance, the mixing device must be perfectly linear and there must be no leakage of the input signals to the output port. Typically, either the sum, or the difference frequency is removed with a filter.</p> <p>The term Double Balanced Mixer is used to imply neither of the input terms will appear at the mixer output. In practice, suppression of these input components is never perfect. Odd harmonics of the carrier frequency are present but can be easily filtered out. In a Single Balanced Mixer, both even and odd harmonics are present at the output.</p>
Noise Figure	<p>Noise Figure is defined as the signal-to-noise ratio at the input divided by the signal-to-noise ratio at the output. Noise Figure is expressed in dB.</p>



Parameter	<p>A parameter is a quantity which influences the radar video, the subsequent signal processing, the plot extraction, or the target tracking. Examples are: transmitted power, video sampling rate, video threshold for plot selection, and expected maximum speed of target.</p>
Plot	<p>A radar plot is a group of connected radar cells in which the measured video signal exceeds a defined threshold value and/or fulfils some other discrimination criterion.</p>
Precision	<p>The standard deviation of repeated measurements of the same quantity under identical conditions i.e. the standard deviation of the measurements of the range to a fixed reference target.</p>
Profile	<p>A profile is a set of common operational parameters for the transceiver and the VDT. Profiles are identified by a name. When a specific Profile i.e. Profile Name is chosen by the operator all transceiver and VDT parameters are set according to the profile content.</p>
Pulse Compression	<p>For a simple rectangular pulse, the pulse duration is equal to the reciprocal value of its bandwidth. Improving the radar sensitivity by increasing pulse duration and thereby the transmitted power, will have a negative impact on the range resolution.</p> <p>Pulse compression, also known as pulse coding, is a signal processing technique designed to maximise the sensitivity and resolution of a radar system.</p> <p>By manipulating the amplitude and phase of a pulse, it is possible to increase the pulse bandwidth, while keeping the pulse duration unchanged, or vice versa. By doing so, the increased average transmitted power improves sensitivity while having a high range resolution.</p> <p>The effectiveness of a particular pulse code is often judged by its time-bandwidth product. The time-bandwidth product for a simple rectangular pulse is equal to one. A compressed pulse might have a time-bandwidth product of ten. This means that each compressed radar pulse contains ten times the energy of the simple un-coded pulse of the same resolution. Equivalently, range resolution is ten times finer than an un-coded pulse of the same duration.</p>
Radar Cell	<p>The disc around the radar out to the maximum range is covered by a polar grid. In the present VDT the polar grid consists of 4096 equal azimuth sectors. Each azimuth sector is divided into 4096 range cells of equal range depth. A specific range cell in a specific azimuth sector is called a radar cell.</p>

Radar Cross Section	The Radar Cross Section (abbreviated RCS) is the size and ability of a target to reflect RF energy - this is summarized in a single term, which has the dimension [m ²]. The size of the RCS depends on frequency, antenna polarisation and a lot of characteristics of the target, ex. physical dimensions, aspect angle, coating and material, surface. The RCS can be quite difficult to estimate and is normally determined by measurements and in certain extend experience.
Radial Speed	The true velocity of an airplane is composed of three vectors. The vector, which points directly towards the radar or away from the radar, represents the radial speed of the airplane. Assuming, an airplane is flying around the radar in a circle path, the radial speed will be permanently zero. The produced Doppler frequency is zero and the airplane is not detected.
Resolution	The minimum distance in range or angle between two equally strong radar targets (same radar cross section) which allow the echoes from these targets to be perceived as separate echoes.
Scan	The collection of consecutive sweeps covering one full rotation.
SSI Filter	<p>An SSI filter performs a sweep-to-sweep integration, where a pre-selected number of consecutive sweeps are averaged. Only the amplitude is taken into consideration. The sweeps will contain a number of targets which have the same position from sweep to sweep. The sweeps will also contain noise which is sporadic and the noise spikes will have random positions in the sweep.</p> <p>By making an average of a number of sweeps, the targets will add up and the noise spikes will not (due to the randomized positions).</p>
Staggered PRF	Staggered PRF is mainly used to cope with multiple-time-around echoes. In fact, targets at ranges greater than maximum range appear as echoes of the following pulses at shorter range. It is possible to remove this range ambiguity by changing the PRI during time-on-target. With different PRIs, the target will appear at different ranges. Using a proper logic, it is possible to identify the echo as a second-time-around one, and assign to it the proper range.
Sweep	The radar return of one transmitted pulse as a function of range.
Track	The track of a target is a table holding position, speed, course, etc versus time.



Tracking	Tracking is the process of associating a time series of plots with the physical movement of one physical object (the target) and to derive speed, course etc from this time series.
Track update	A track is updated when a plot from the most recent scan is associated to a tentative or a confirmed track.
Trail	Historic radar echoes, usually presented in a color different from the actual radar echoes and fading away within a user defined time interval.
Waveguide	Hollow metal conductor within which RF energy can be efficiently transmitted.

1.6 Abbreviations and acronyms

Term	Definition
2D	Two-dimensional
A-SMGCS	Advanced Surface Movement Guidance and Control System
ACP	Azimuth Count Pulse
ACU	Antenna Control Unit
ADC	Analog to Digital Converter
ARP	Azimuth Reference Pulse
ASC	Adaptive Sensitivity Control
ATC	Air Traffic Control
BITE	Built-In Test Equipment
CFAR	Constant False Alarm Rate
CNR	Cahier des charges sur les normes radioélectriques
CNR-Gen	Exigences générales relatives à la conformité des appareils de radiocommunication
CP4	Common Platform Board 4
CRP	Chirp Repetition Frequency
EIA	Electronics Industries Alliance
EMC	ElectroMagnetic Compatibility
EMCON	EMission CONtrol
ESD	ElectroStatic Discharge
FCC	Federal Communications Commission

Term	Definition
FD	Frequency Diversity
FPGA	Field Programmable Gate Array
FTP	File Transfer Protocol
HAZCHEM	Hazardous Chemicals
I/O	Input/Output
ICAO	International Civil Aviation Organization
ICNIRP	International Commission on Non-Ionizing Radiation Protection
IEC	International Electrotechnical Commission
IF	Intermediate Frequency
IP	International Protection / Internet Protocol
ISDE	Innovation, Sciences et Développement économique Canada
ISED	Innovation, Science and Economic Development Canada
ISO	International Standardization Organization
Kn	Knots
LAN	Local Area Network
LRU	Line Replaceable Unit
LVDS	Low Voltage Differential Signalling
MDR	Minimum Detectable Range
MDS	Minimum Detectable Signal
MMIC	Monolithic Microwave Integrated Circuit
MTI	Moving Target Indicator
nmi/NM	Nautical Mile
PA	Power Amplifier
PC	Personal Computer
PRF	Pulse Repetition Frequency
PSLR	Peak Sidelobe Level Ratio
RCS	Radar Cross Section
REACH	Registration, Evaluation, Authorisation and Restriction of Chemicals
RF	Radio Frequency
RH	Relative Humidity



Term	Definition
RoHS	Restriction of Hazardous Substances
RPM	Rotations per minute
RS	Recommended Standard
RSS	Radio Standards Specification
RSS-Gen	General Requirements for Compliance of Radio Apparatus
Rx	Receive / Receiver
RxTx	Transceiver
SCM	Static Clutter Map
SMR	Surface Movement Radar
SNR	Signal-to-Noise Ratio
SNTP	Simple Network Time Protocol
SSPA	Solid State Power Amplifier
STC	Sensitivity Time Control
STW	Setting-To-Work
SVHC	Substance of Very High Concern
TCP/IP	Transmission Control Protocol / Internet Protocol
Tx	Transmit / Transmitter
UDP/IP	User Datagram Protocol / Internet Protocol
UL	Underwriters Laboratories
USB	Universal Serial Bus
UV	Ultra Violet
VAC	Voltage Alternating Current
VDC	Voltage Direct Current
WAN	Wide Area Network

1.7 Referenced documentation

605502-DP	SCANTER 5502 Surface Movement Radar, Product Specification
605602-DP	SCANTER 5602 Surface Movement Radar, Product Specification
357641-HO	SCANTER Radar Service Tool, Operator's Manual



262106-HO	Static Map Tool, Operator's Manual
695522-TI	SCANTER 5000/6000 Series Setup And Adjustment
386303-DI	SCANTER 5000 Series Transceiver Control Protocol Data Definition - Service Access Mode
619556-MM	Setup of Frequency Converters
978100-HT	SCANTER Antenna Control Units, Technical and Maintenance Manual
924000-RC	Power Density in Proximity to SCANTER transceivers with High Gain and DBHG+ Antennas
970637-HT	Warnings and Safety Instructions for Terma Radar Antenna Systems
659002-ND	Label, ACU



(Intentionally left blank)

2 SCANTER 5502/5602 Radar Systems

The Terma SCANTER 5502/5602 radar systems are designed to perform airport surveillance, integrated as the primary sensor in an airport Advanced Surface Movement Guidance and Control System (A-SMGCS).

The SCANTER 5502/5602 radar systems (Fig. 2.1 (p. 27)) are X-band, 2D, fully coherent pulse compression radars, based on Solid State Power Amplifier (SSPA) transmitter technology with digital software-defined functionality.

The SCANTER 5502 radar system is tailored for SMR only. The transceiver contains a 50 W SSPA transmitter and delivers normal radar video for the detection of SMR targets.

The SCANTER 5602 radar system is tailored for combined SMR and near-range ATC purposes. The transceiver contains a 200 W SSPA and an extra signal processing board to provide normal radar video as well as Doppler-processed (MTI) video. This allows for detection of SMR targets as well as detection of approaching and departing aircraft up to a range of approx. 5 NM from the radar site.

Novel low-temperature SSPA transmitter technology optimizes the investment, and the long-life transmitter ensures high reliability and availability. The availability is further enhanced with provision of graceful degradation.

A receiver with superior dynamic range provides high resolution in the full range with clear and crisp radar pictures, in all weather conditions.

High-speed sampling is made on IF level, and all subsequent handling of signals, filtering, pulse compression is performed digitally. Advanced range CFAR technique and video processing with intelligent noise reduction provide high definition radar images with no need for further processing.

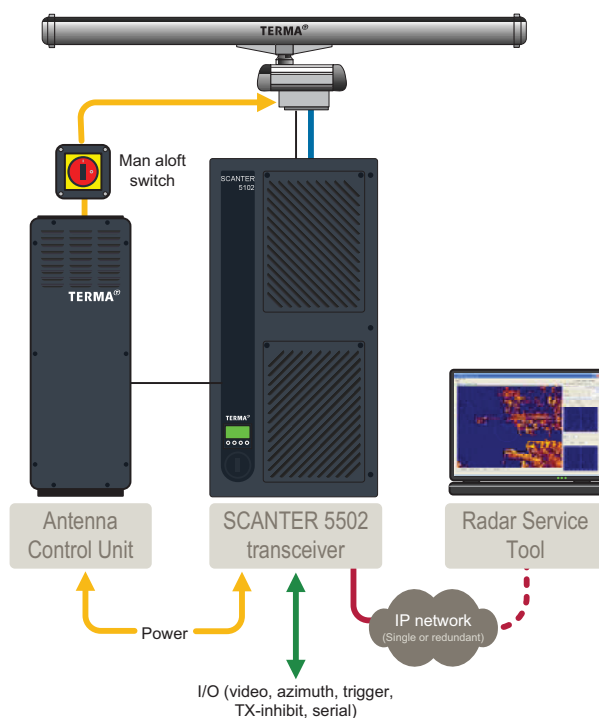

Fig. 2.1 Simplified system components schematics



Communication interface to the transceiver is established via a standard IP network (LAN or WAN), which provides network radar video and control. Conventional digital video is also available.

A temperature-conditioned environmental housing for the transceiver may be supplied for outdoor installation or for use in other harsh environments as add-on feature.

Service information is obtained via the front panel display and/or the IP network.

The SCANTER 5502/5602 SMR are high-end radar systems, in compliance with the EUROCAE and ICAO requirements and recommendations

The SCANTER Service Display (Radar Service Tool) provides access to powerful radar imaging, control, BITE measurements, error handling and fault finding.

2.1 Configurations

The SCANTER 5102/5202 Radar System is available in single and redundant configurations. According to configuration, the SCANTER 5102/5202 consists of the standard components shown in the table below.

Simplified system drawings are shown in the sections below, and further details are available in the applicable installation drawings. Refer to section [1.7 \(p. 24\)](#).

System configurations
High Gain antenna
Fixed turning unit
Transceiver(s), single or redundant
Antenna control unit (ACU)

2.2 Single transceiver system configuration

A complete radar sensor ([Fig. 2.2 \(p. 29\)](#)) system consists of a transceiver, an - Antenna Control Unit (ACU) and an antenna unit. Service Display software handling radar video imaging, control, set-up, BITE, etc. is also included. A PC for running the RST software may be added, either as a rack mounted PC or as a portable solution.

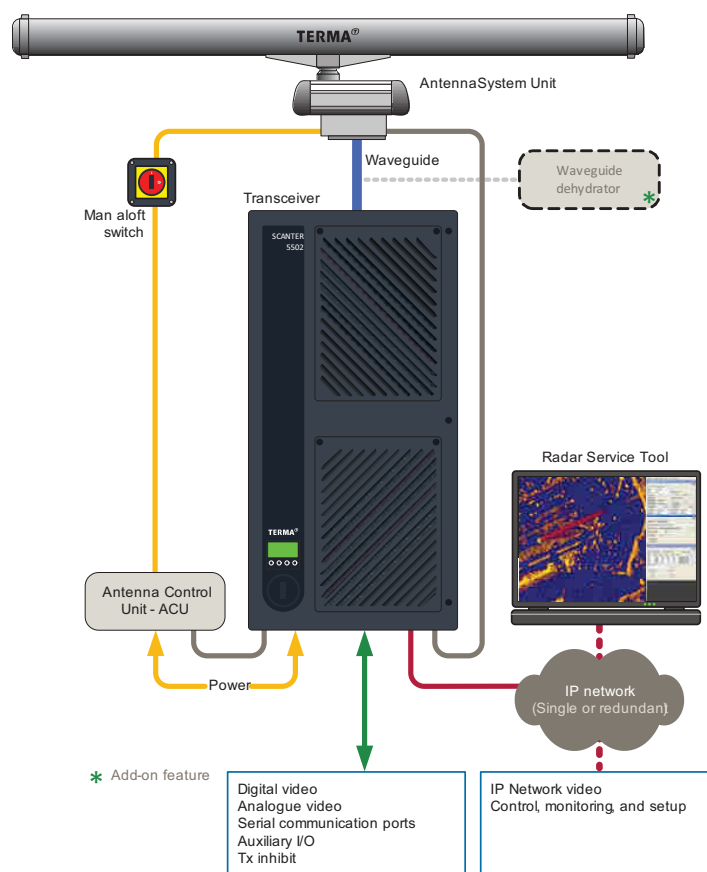

Fig. 2.2 Single transceiver system configuration

The transceiver is a one-box wall-mounted unit and all connections except the waveguide are connected at the bottom of the housing.

IP network video is available as well as IP network transceiver control, monitoring and set-up.

Auxiliary I/O, serial communication ports for mounting external equipment such as MET (weather station) etc. as well as conventional digital video output are available.

Mains power supply to the antenna unit is via an ACU (Antenna Control Unit) controlled by the transceiver. Antenna unit status, encoder signals, and man aloft switch are connected directly to the transceiver.

2.3 Redundant transceiver system configuration

The SCANTER 5502/5602 redundant system configurations (Fig. 2.3 (p. 30)) are fully redundant in respect of all transceiver functions. Features include automatic switch-over (only once) in case of failure, and "graceful degradation" is included in the SSPA transmitter in the transceiver.

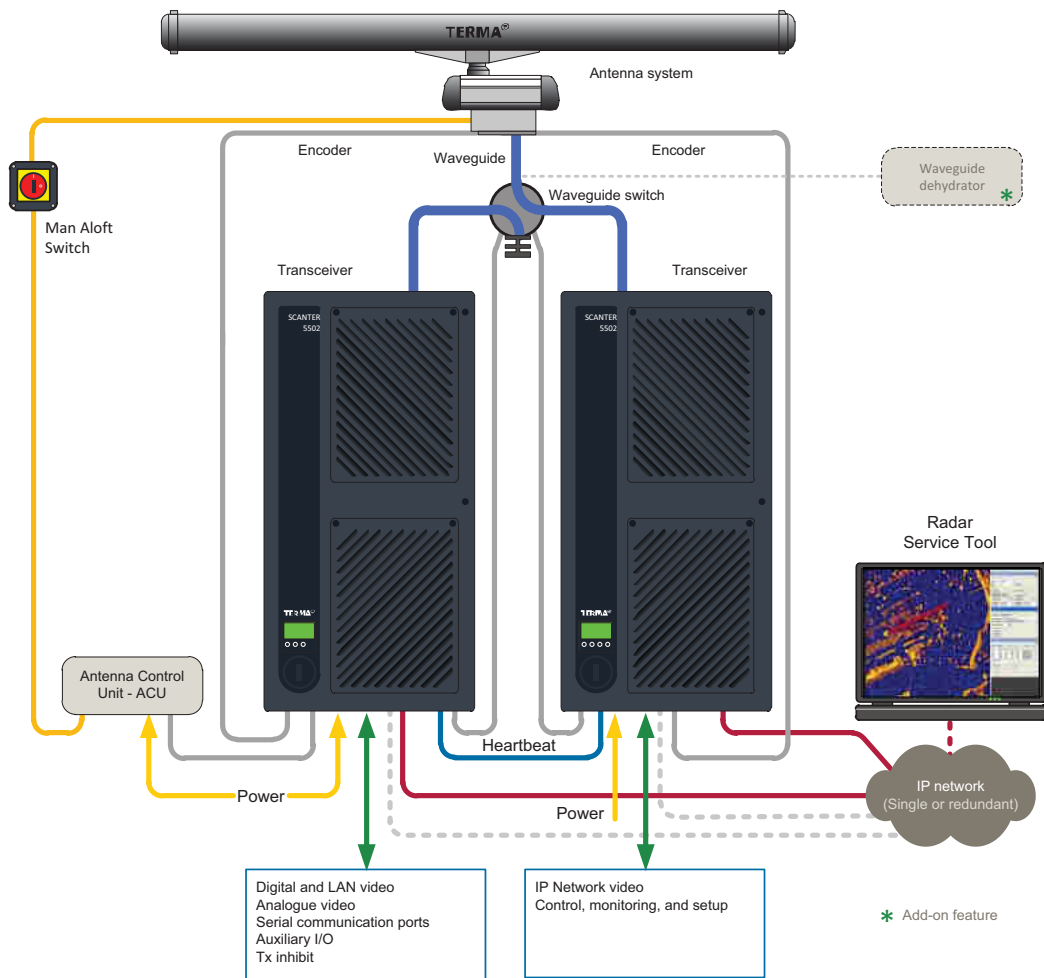

Fig. 2.3 Redundant transceiver system configuration

Waveguide switch and dummy load are installed externally to the transceivers on a metal frame.

2.3.1 Redundant transceiver operation

In a redundant transceiver configuration, most of the parameters are identical in the two transceivers, except for a few site-specific parameters, e.g. IP address. Consequently, any changes to the parameters in one transceiver must also be made in the other transceiver.

Redundancy ensures continuous operation of the radar in case of critical transceiver failure. In a redundant transceiver system, the transceivers communicate a heartbeat signal via a LAN network connection.

Each transceiver has a unique IP address. Thus, setting up redundant system mode must be done for each individual transceiver by connecting the Radar Service Tool (RST) to the transceivers. An instance of the RST client can be run for each transceiver when setting the parameters.

The mains and antenna parameters must be set to “On” and the Tx parameter must be set to “On” for both transceivers. In addition, the same profile must be selected for both transceivers. Any transceiver can be made active by selecting “Force” in the Redundant System Failover parameter.

To prevent a radar transmission stop in case of a critical failure, both the active and passive transceiver in a redundant system must allow for automatic switch-over. This is done by setting the parameter Redundant System Failover to “Enable”. In case of failure on the active transceiver, transmission then automatically changes to the passive transceiver, and the Redundant System Failover enabled in both transceivers is disabled. When the error in the failing transceiver is corrected, failover in both transceivers must be re-enabled manually to allow for automatic switch-over in case of future failures.

For detailed information on setting up transceiver redundancy, see “Setting up transceiver redundancy (redundant systems only)” on page 153.

For detailed information on activating a transceiver, see “How to activate a transceiver (redundant systems only)” on page 158.

Redundant system errors must be critical in order to disable a transceiver. An example of such error is “Noise Figure High Error”. For an overview of “Redundant System Critical Errors”, see “BITE errors and warnings” on page 167.

2.4 SCANTER 5502/5602 product technology and features

Built on the flexible, versatile design and superior price/performance heritage from the previous non-coherent radars, the new generation introduces fully digital signal processing and solid-state technology.

SCANTER 5502/5602 uses fully coherent, pulse compression technology to get superior resolution and radar image quality. The radar transmits chirps with frequency sweeps in different intervals generated by a digital synthesizer. The chirps are up-converted to X-band frequencies, and the output power is generated by a microwave SSPA (Solid State Power Amplifier).

In order to support full frequency diversity, the receiver has two channels receiving the different frequencies. The signals from the two receiver channels are sampled in 14 bits at 400 MHz, yielding a stream of 11.2 Gbit/s of raw data.

This data stream is input to the processing chain, which uses multiple FPGAs (Field Programmable Gate Arrays) in a modular configuration to perform the calculations and data reduction needed to provide crisp and noise free radar images.

All components but the transmitter amplifier and receiver front-end are purely digital. The necessary processing power is added in the form of plug-in CPs - Common Platform processing boards - in order to minimize the number of different LRUs. The CP boards are identical, but are programmed differently, according to desired functions.

Technology and features are listed below.



- Software-defined functionality
- Frequency Diversity and Time Diversity
- Full coherency and pulse compression
- Transmitter power level control in sectors
- Video processing
- Environment adaptation (SCANTER 5602 only)
- Control / Profiles / BITE
- SCM interference
- Doppler-based processing (SCANTER 5602 only)

The necessary processing power is added in the form of plug-in CP4 (Common Platform 4) processing boards. The CP4 boards are electrically identical, but are programmed differently, according to desired functions.

Featuring	
SMR Surface Surveillance, Full Coherence, Frequency and Time Diversity	●
A-SMGCS integration	●
Frequency	
Programmable frequencies within 9.0–9.5 GHz (default frequency interval: 9.0-9.2	●
Up to 16 sub-bands	●
Transmitter	
50 W SSPA: 0-20 kW equivalent pulse power, programmable	●
Receiver	
Digital Sampling on IF, ≥ 140 dB amplitude span of signals handled	●
Range cell size: 3 m	●
Processing	
SCM interference	●
External Interfaces	
Analogue, digital and IP network radar signals	●
Control and monitoring via IP network / serial connection ports	●
Design	
Open architecture, wall/bulkhead mounted, ruggedized housing	●
Maintenance	
Local and remote access to radar video, control and monitoring	●
BITE for fault management and diagnosis	●
Antennas	
18' or 21' High Gain Linear Array, CP, Fan or Inv. Cosec ²	○
Standards	
EuroCAE ED-116:2004, ICAO Doc 9830/AN452, EuroCAE ED-109:2012, IEC 60950-1, 2nd Ed., EN303213-6-1, ITU-R SM.1541-6 Annex 8, ITU-R SM.329-12, Cat. B, IEC 61000, CISPR16-2, IEC 60945:2002, IEC 60529.	●

● Standard feature
○ Add-on (optional) feature

Fig. 2.4 SCANTER 5502 features

	5602
ig	
rface Surveillance, Full Coherence, Frequency and Time Diversity	●
DS integration	●
icy	
imable frequencies within 9.0–9.5 GHz (default frequency interval: 9.0-9.2 GHz)	●
i sub-bands	●
itter	
iSPA: Up to 50 kW equivalent pulse power, programmable	●
r	
ampling on IF, ≥ 140 dB amplitude span of signals handled	●
ell size: 3 m	●
ing	
-based processing	●
erference	●
I Interfaces	
e, digital and IP network radar signals	●
and monitoring via IP network / serial connection ports	●
chitecture, wall/bulkhead mounted, ruggedized housing	●
iance	
id remote access to radar video, control and monitoring	●
fault management and diagnosis	●
is	
High Gain Linear Array, CP, Fan or Inv. Cosec ²	○
ds	
ED-116:2004, ICAO Doc 9830/AN452, EuroCAE ED-109:2012, 50-1, 2nd Ed., EN303213-6-1, ITU-R SM.1541-6 Annex 8, M.329-12, Cat. B, IEC 61000, CISPR16-2, IEC 60945:2002, IEC 60529.	●

Fig. 2.5 SCANTER 5602 features

2.4.1 Doppler-based processing (SCANTER 5602 only)

The Doppler-based processing option allows the transceiver to separate moving targets from background clutter and provides an additional video channel with moving objects. The Doppler processing option includes an additional processing board (CP4 board) in the transceiver.

2.4.2 Physical appearance of SCANTER 5502/5602

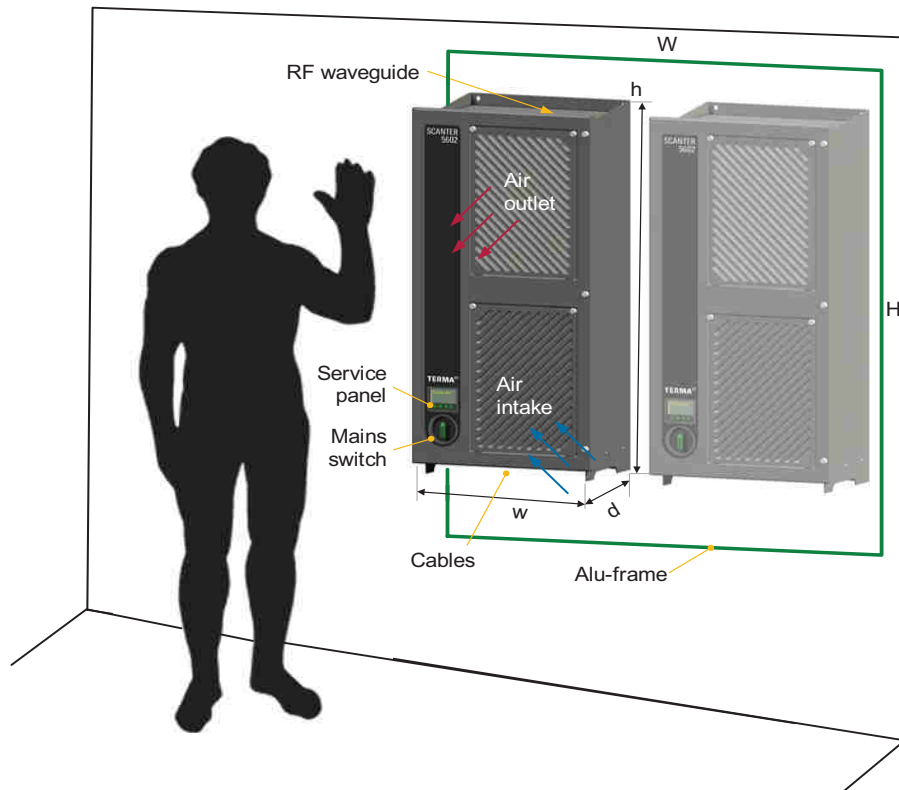

Fig. 2.6 Wall-mounted transceiver dimensions

	Single system
Weight:	≈ 77 kg net. ≈ 120 kg packed for transportation
h x w x d	990 x 497 x 305 mm installed ≈ 610 x 1050 x 660 mm packed for transportation
	Redundant system
Weight:	≈ 165 kg net. ≈ 220 kg packed for transportation
H x W x d	1530 x 1130 x 350 mm installed on alu-frame ≈ 610 x 1300 x 1700 mm packed for transportation

The transceiver contains a number of LRUs - Line Replaceable Units - as illustrated below.

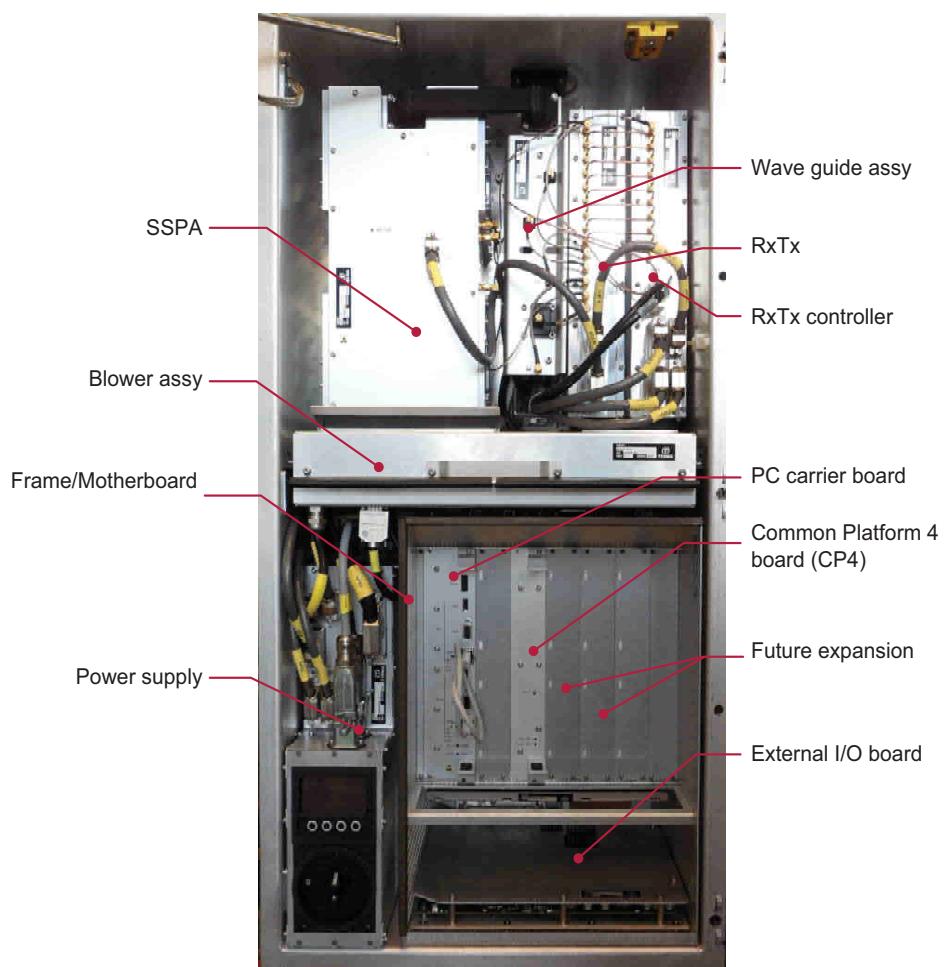

Fig. 2.7 The interior of the SCANTER 5502/5602 transceiver



(Intentionally left blank)

3 Functional Description

The transceiver is the central component in the radar system. See Fig. 3.1 (p. 37). The transceiver is connected to signal distribution through single or redundant IP network(s). Serial communication lines are available, handling easy integration into other sub-systems. The recommended video outputs are digital and IP network formats.

The transceiver utilizes frequency modulation (chirping or frequency sweeping) and pulse compression to increase the range resolution as well as the signal-to-noise ratio. This allows for transmission of long frequency modulated pulses (chirps) with relative low peak power, but still gets a high range resolution and probability of detection.

By the digital frequency synthesis, any frequency within the frequency bands 9000-9200 and 9225-9500 is selectable as required by the application (default frequency interval for SMR systems is 9000-9200). The signal is generated in the radio controller and up-converted in the transmitter. The receiver will automatically tune to the transmitted frequency bands and pass the received signal to the radio controller which will sample the signals and combine the data stream from the two receiver channels.

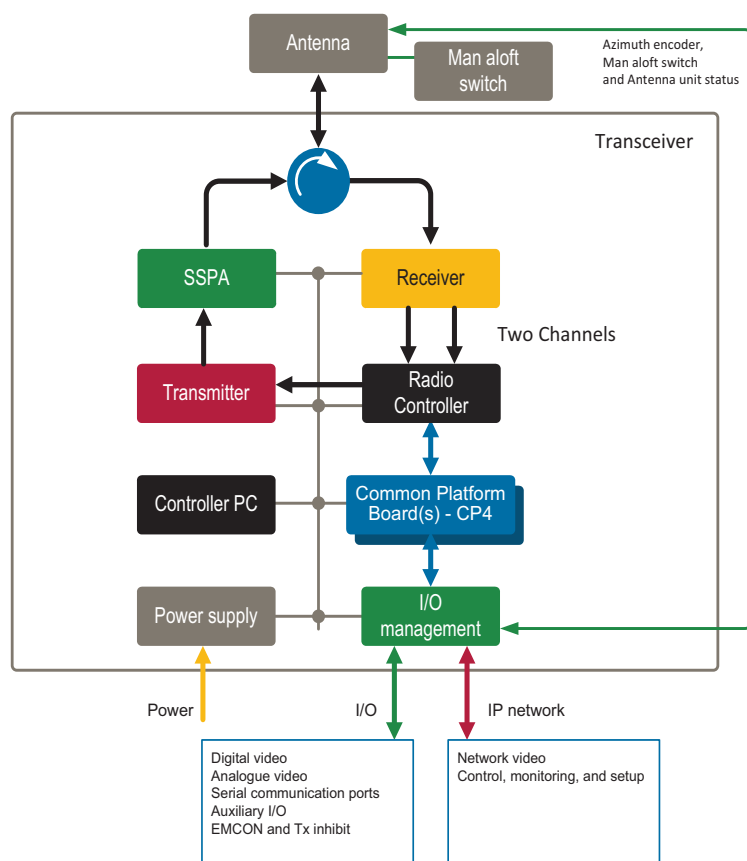

Fig. 3.1 Transceiver block diagram



The receiver has two channels in order to support simultaneous reception of two frequency bands. Optimum signal-to-noise performance is ensured by low noise amplifiers.

In the SCANTER 5502/5602, the processing is done in the digital domain. The chirps are fed directly from the Analog to Digital Converter (ADC) into the IF mixer feeding the Solid State amplifier.

The signal returns are as early as possible converted from the analog domain back to the digital domain, where all processing takes place.

Highly advanced proprietary processing techniques follow, providing normal radar video. Video is converted from linear to logarithmic before making it available for tracking and image presentation.

Integrated BITE functions perform continuous monitoring of the radar during start-up and operation. This includes temperatures, voltages, signal activity, key performance parameters, etc. The receiver noise figure, forward and reverse power are used for performance monitoring.

3.1 **Software-defined functionality**

Multiple types of SCANTER radars utilize identical core software, which enables a high level of testability, ensures deployment flexibility and makes it easy to add new functionality.

A variety of radar signal processing techniques are available. Multiple functions, such as automatic adaptation to weather scenarios etc., are performed simultaneously. This, in combination with the use of multiple, identical and powerful, common platform processing modules, leads to the concept “software-defined functionality”.

The entire processing structure is defined by software and functions relevant for the individual application and are invoked as appropriate. It is also possible to switch between different modes of operation by modifying both the synthesized transmit waveforms and receive signal processing tasks, even on the fly. Additional parallel coherent transmit and receive channels enable video processing (*FiveStepVideo-Passing*).

In summary, the radar transceiver is configured to the application scenario, and adaptation to the environment is highly automated.

3.2 **Solid State Power Amplifier (SSPA)**

The Solid State Power Amplifier (SSPA) modules for the SCANTER 5502/5602 are designed using state-of-the-art MMIC (Monolithic Microwave Integrated Circuit) power transistor amplifiers.

Each Power Amplifier (PA module) consists of 8 power transistors. The PA amplifies the signal to be transmitted and produces 50 watt of microwave power.

The SCANTER 5502 contains one power module, whereas the SCANTER 5602 contains four modules providing 200 W output power.

The power sector mode feature allows the SSPA output power to be adjustable in azimuth sectors.



Fig. 3.2 SSPA modules. 200 W to the left and 50 W to the right

3.2.1 SSPA graceful degradation

Careful integration of several power transistor modules ensures limited SSPA failure in the event of a loss of one or more individual power transistors.

This means that loss of a single or few power transistors will only result in marginal drop of performance. However, the power transistors loss will be reported by the BITE system. It is therefore possible to design a system with a margin allowing for one or more failing power transistor and postpone replacements until it becomes convenient.

The figure illustrates the relation between loss of modules, peak power and free space range performance of the radar.

The free space range performance assumes line of sight from radar to target and excludes any influence from propagation, clutter or precipitation.

[Fig. 3.3 \(p. 40\)](#) shows that at 50% of power transistors in failure, 25% output power remains. However, 70% of the free space range is achievable.

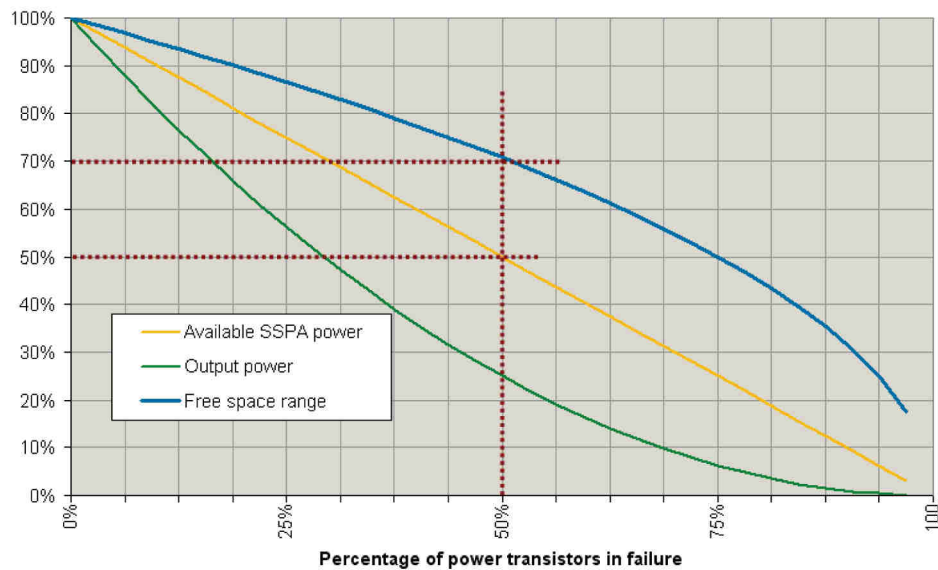

Fig. 3.3 Free space range and power vs. power transistor failure

3.3 Frequency diversity and time diversity

The effect of the Terma SCANTER Frequency and time Diversity processing is to reduce fluctuation of the echoes from desirable targets, and thereby enhancing targets relative to clutter. In combination with full coherence and pulse compression the radar images becomes crisp and clear.

The transceiver operates with Frequency Diversity (FD). FD is sequential transmission on six different frequencies followed by recombination of the echoes from the different frequencies.

Each of the six different base frequencies are frequency modulated with chirps. Three chirp lengths are utilized. A long chirp to increase RF energy for long-range detection, short chirps to ensure high short-range detection, and medium chirps to cover the range between short chirp maximum range and long chirp minimum range.

The frequency diversity enhances detection of very small targets like rubber dinghies, even under special weather and climatic conditions.

The primary advantage of Frequency Diversity operation is that target fluctuations are reduced after integration of signals from independent pulses, removes second time around echoes, and improves interference resilience.

The use of modulated RF and multiple chirps on a slotted waveguide antenna will result in actual beam directions different from the antenna direction (and the apparent bearing of the target). This is illustrated in Fig. 3.4 (p. 41). The beam offset due to frequency is illustrated by colors (yellow and green). This phenomenon is called squint.

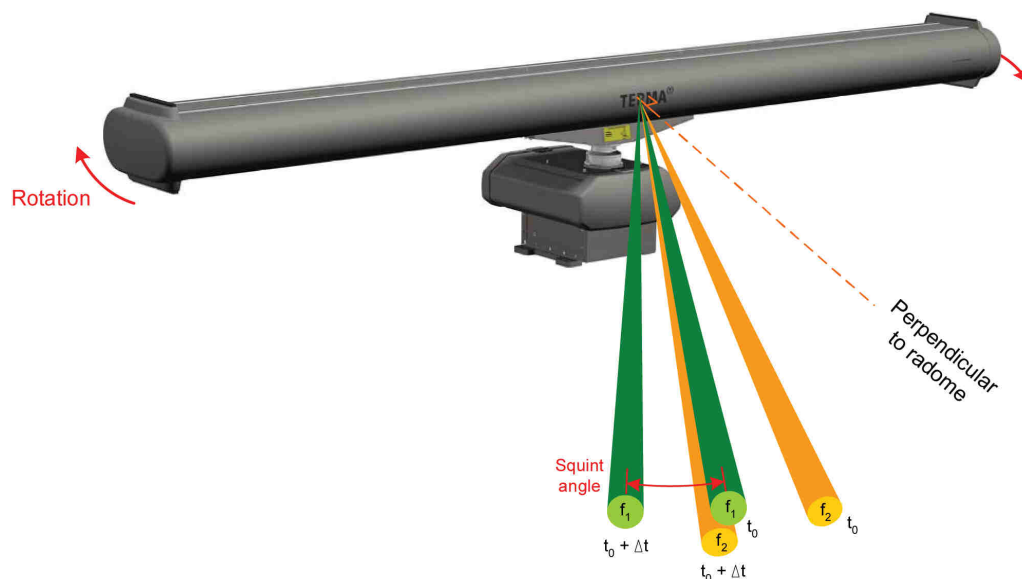

Fig. 3.4 Squint angle

The offset due to transmission timing and rotation (with same frequency component) is shown by indexes (t_0 and $t_0 + \Delta t$). The return signals, corresponding to a given antenna direction (dashed line in the figure), need to be combined and corrected by alignment in range and in azimuth.

The linear array antenna with the SCANTER 5502/5602 will transmit the chirps of the six carrier frequencies in different directions. The targets and clutter will be hit by the independent beams at different times as the beams corresponding to different carrier frequencies are separated by the difference in squint angle.

The additional benefits from correlation, integration, and time delay due to the squint entail additional performance compared to single frequency only.

3.4 Full coherency

SCANTER 5502/5602 is a fully coherent system utilizing amplitude and phase information during transmission and reception. A common, phase stable oscillator is used for transmission and reception. Pulse compression is achieved by comparing a recorded copy of the transmitted chirp with the echo signals returned from targets and clutter. Further, coherency allows the receiver to compare the phases of the received echoes from chirp to chirp and thereby detect if targets are moving or not, utilizing the Doppler shift. Doppler-based processing is available as an option. This improves detection of targets moving radially (moving in range) and with speeds different from clutter.

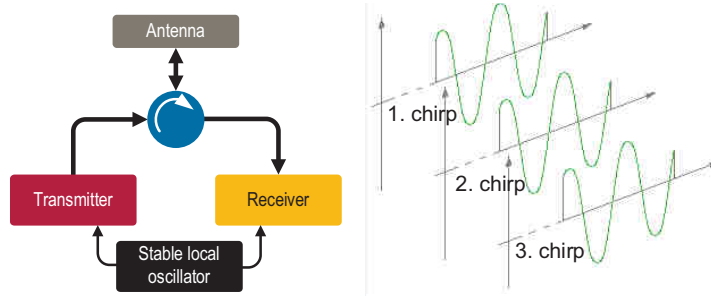

Fig. 3.5 Coherency principle

3.5 Pulse compression

While a magnetron-based radar is capable of transmitting many kilowatts of power, a solid state radar has a much lower peak power. In order to illuminate a target with sufficient energy for detection, it has to transmit much longer pulses. Unless some clever processing is used, this would lead to a significant loss of range resolution. The SCANTER 5502/5602 transceivers utilize frequency modulation (chirping or frequency sweeping) and pulse compression to increase the range resolution as well as the signal-to-noise ratio.

When closely separated targets reflect these chirps, the frequency content of the echoes from different targets at a given time will be different as illustrated in Fig. 3.6 (p. 42).

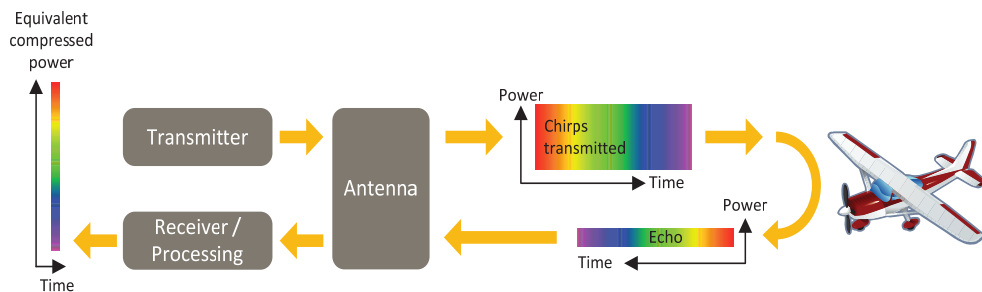

Fig. 3.6 Frequency sweep

Pulse compression is performed in the frequency domain. By pulse compression, the signal-to-noise ratio is improved by the pulse compression gain or a factor, equivalent to the chirp length times the effective bandwidth of the transmitted chirps.

A special feature of the pulse compression technique is that the resulting radar sensitivity to noise is independent of the resolution bandwidth. The resulting SNR is therefore proportional to the transmitted power divided by the overall receiver noise figure. In consequence, the bandwidth is configurable e.g. to minimize the clutter power, having in mind that too fine a resolution will introduce a straddling loss. In other words, the radar sensitivity is determined by the transmitted power (chirp or pulse length), as in normal pulse radar, but the resolution can be selected freely as long as range straddling loss is avoided.

A drawback from the transmission of long chirps is an extended minimum range – the radar is blind during transmission. In order to compensate for this, the radar uses a mixture of short, medium and long chirps.

Because there is a short delay between transmission and reception of an echo from a target close to the antenna, short chirps are used for short ranges. However, since detecting small targets at long distance requires more energy, long chirps are used for long distances while medium chirps are used for covering the intermediate range. See Fig. 3.7 (p. 43).

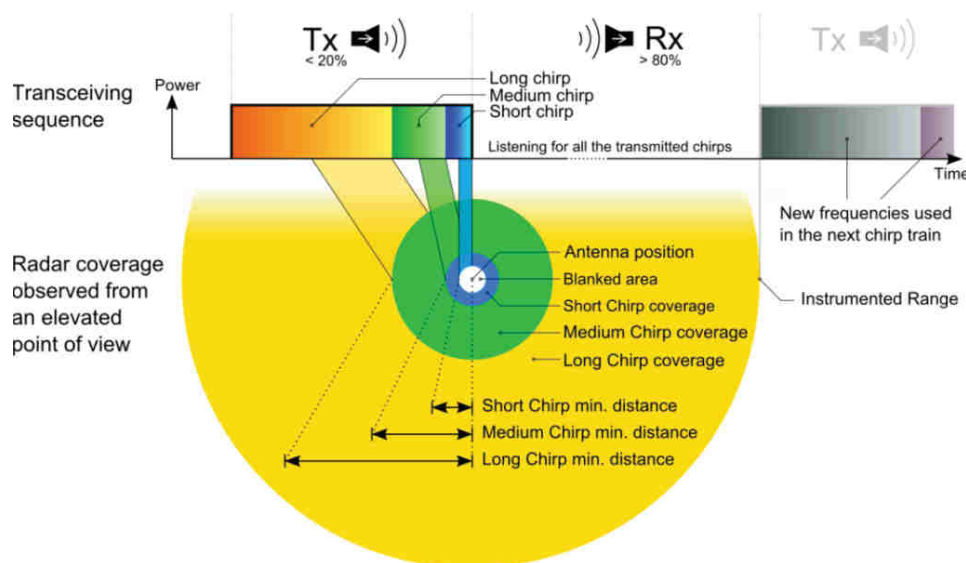

Fig. 3.7 Principle of transmission sequence

Up to 16 sub-frequency bands can be used and the sequence of pulse patterns is fully software defined and can be adapted to the actual situation and the chirp combination (transmission sequence) is defined as part of individual profile set-ups.

By nature, pulse compression will create time side lobes in a radar image. These are imperfections in range, where a target will appear with “artificial” targets before and/or after the actual target. Similar effects, called antenna side lobes, can appear in azimuth.

Side lobes are unwanted, as they will limit the size of a small RCS target that can be detected next to a large RCS target. The ratio between the peak level of the target and the highest time side lobe is called the Peak Side Lobe Ratio (PSLR).

Traditionally this may be a severe limitation in pulse compression radars. However, a new proprietary approach that overcomes this has been developed for the SCANTER 5502/5602 radars. The result is that time side lobes are strongly reduced, in the order of 60 dB below the peak level.

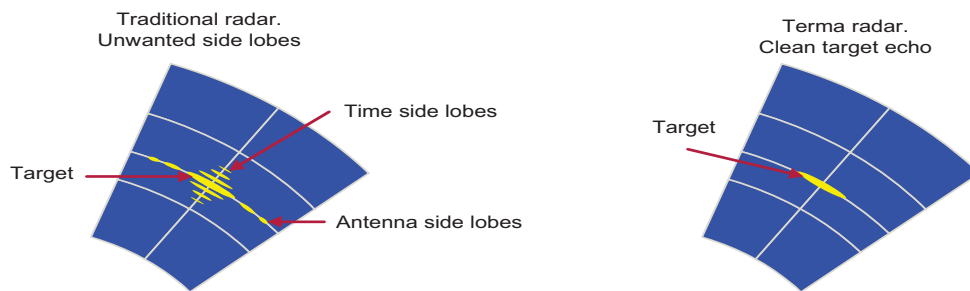

Fig. 3.8 Traditional and Terma SCANTER side lobe behaviour

3.6 Power sector transmission

In order to avoid interference from strong echoes from large stationary targets like buildings or mountains and to reduce the risk of interfering with other X-band systems, a power sector mode is available. This feature allows definition of up to 16 individual user-defined sectors where the transmitted power can be controlled. Each sector is defined as either:

- Prohibit sector
- Transmit sector
- Reduced power sector

The sectors are aligned relative to north. The size of each sector may be chosen freely between 10° and 359° . Each reduced power sector may be given an individual power attenuation.

Prohibit sectors take precedence over transmit sectors.

For the transmit sectors the power may be attenuated by up to 31 dB in each sector, thus providing a mode with low RF emission.

3.7 Sub-clutter visibility and Doppler-based processing (SCANTER 5602 only)

The transceiver supplies two channels at the same time: Normal radar video and Doppler-processed radar video. All targets and clutter will be present in the normal radar channel.

Stationary and near-stationary targets such as earth ground clutter (land, buildings, trees, grass fields, etc.) will have zero or low Doppler shifts, while targets faster radial speed (aircraft, vehicles, etc.) will produce higher Doppler shifts. Therefore, the stationary and near-stationary targets and clutter will be suppressed in the Doppler-processed channel. The enhancement of the moving targets in the Doppler-processed radar video relative to the normal radar video is called sub-clutter visibility.

More specifically, stationary targets and clutter are suppressed by the use of a series of proprietary adaptive MTI filters and correlators. In addition, special proprietary algorithms adapt the MTI filters to the speed of rain clutter, suppressing clutter even when it is moving, all resulting in a clean, crisp display of moving targets only. Below are shown three pictures of an aircraft passing over an area with clutter. The three pictures below display normal radar video, Doppler processed video, and combined video, respectively, on top of a satellite map:



Fig. 3.9 Normal radar video



Fig. 3.10 Doppler-processed (MTI) video

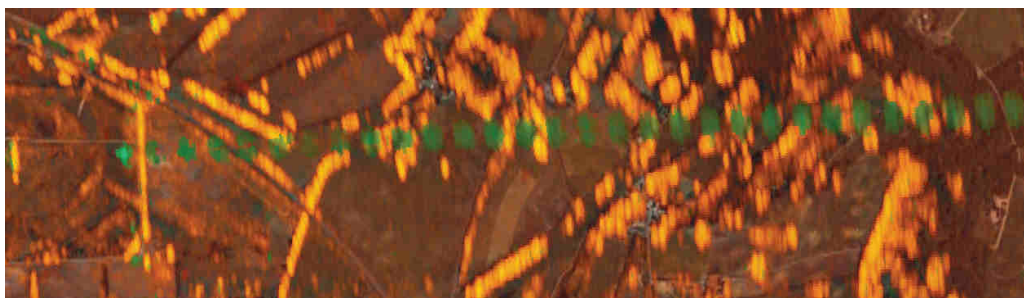

Fig. 3.11 Combined normal radar/MTI video

SMR targets are detected in the normal radar channel, but the Doppler-processed channel can be used to enhance the detection of SMR targets on the ground provided their radial speed is above the suppression threshold. Typically taxiing aircraft and moving cars can be detected in this channel unless they are moving perpendicularly to the line-of-sight from the radar.

3.8 Video processing

After down conversion in the receiver, the signal is sampled with 14 bit at high speed and demodulated. After demodulation pulse compression is performed, followed by interference filtering; these two functionalities are common for SCANTER 5502 and SCANTER 5602.

Five step video processing is then applied in order to have a video output for display and tracking.

Video processing for SCANTER 5502 is shown in Fig. 3.12 (p. 46).

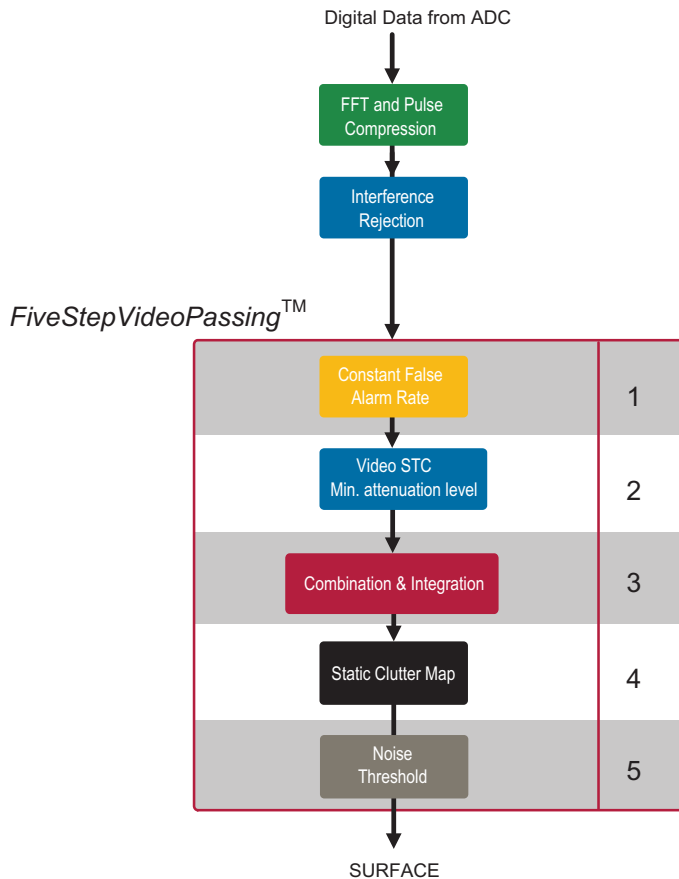

Fig. 3.12 SCANTER 5502 video processing, simplified

The video processing includes CFAR processing and adaptation of the signal amplitude to the dynamic range (Minimum Attenuation Level). Combination and integration are based on algorithms that minimize the loss in order to have optimum sensitivity. A static clutter map makes it possible to suppress static clutter areas. The noise-thresholded video output is converted from linear to logarithmic as part of the processing.

SCANTER 5602 has a surface channel with the same processing as SCANTER 5502. In addition, it has an air channel where MTI processing is applied in order to have sub-clutter visibility. The MTI allows for detection of aircraft, as stationary targets are suppressed from moving targets. The air channel has adaptive clutter processing based on statistics.

The output of the air and surface channels can be merged into each other.

Video processing for SCANTER 5602 is shown in Fig. 3.13 (p. 47).

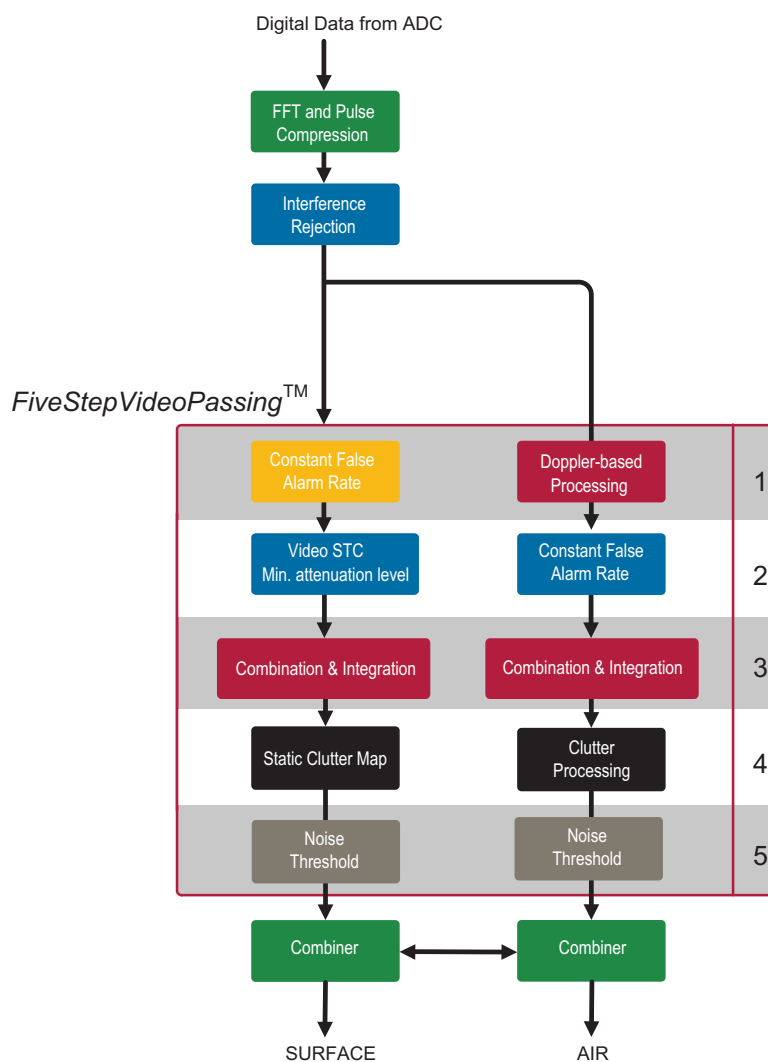

Fig. 3.13 SCANTER 5602 signal processing, simplified

3.9 Static clutter map and blanking

The clutter map provides two-dimensional (range and azimuth) swept video attenuation as well as blanking (on video level) of unwanted stationary targets.

A programming tool, Static Map Tool, running on the Service Display defines two-dimensional swept gain and blanking maps. The map definitions are based on a site map of the individual airport.

For further information on how to use the Static Map Tool, refer to doc. no. 262106-HO.

3.10 Environment adaptation

A false alarm is an erroneous radar target detection caused by clutter, noise or other interfering signals exceeding the detection threshold. In general, it is an indication of the presence of a radar target when there is no valid target.

CFAR – Constant False Alarm Rate – and other adaptation techniques provide automatic adjustments such as false alarm rate. CFAR provides a flat noise floor - also based on proprietary algorithms.

Antenna side lobe suppression is an integral part of the CFAR function.

3.11 Controlling and using the radar

3.11.1 Local and remote control

The radar can be controlled and monitored in several different and parallel ways.

- On the transceiver itself, a display and buttons are mounted, from where IP settings, errors and warnings, etc. can be accessed locally.
- On the Service Display, a software package (RST) connects to the transceiver via an IP network connection. From the software package all parameters, settings, BITE measurements and errors can be accessed. Furthermore, a Plan Position Indicator (PPI) view is included in the RST.
- Via an open IP network protocol, all parameters, settings, BITE measurements and errors can be accessed.

Radar video is available as analog video, digital 8 bit LVDS video and TCP/IP network video.

3.11.2 Profiles

Profiles are predefined parameter sets used to set optimal transceiver performance according to varying weather conditions or specific operational demands. Thus, the 16 available profiles allow the operator to adjust the radar system transmission mode and/or receiver processing in a fast and reliable way.

The profiles eliminate the risk of maladjustment of the radar and reduce the operator need to acquire detailed knowledge about radar characteristics and meaning as such.

At any time, the operator may set a specific radar parameter, e.g. chirp width, to override the definition of the profile.

The profiles are selectable via the Service Display or per remote IP network.

3.11.3 Built-in Test Equipment (BITE)

Continuous status monitoring of a significant number of parameters/signals on each module is performed in real time by the housekeeping system. The status of the parameters/signals is internally assessed to initiate appropriate actions automatically to maintain operation to the extent possible if an error is detected.

The BITE reporting, see Fig. 3.14 (p. 49), clearly describes the actual event or error and relates it to a specific module, i.e. no need for translation of code numbers. The details of these reports will allow identification to the level of the Line Replaceable Unit at fault.

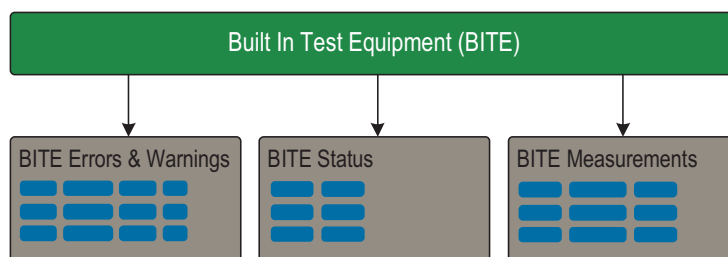

Fig. 3.14 Built-In Test Equipment (BITE)

At power up, the following diagnostic tests are performed:

- Module presence test.
- Data Link test.
- Memory test of all RAM circuits.

The BITE monitors the system during standby and operation and reports the following:

BITE errors/warnings:	Signal activity and processes. Internal supply voltages. Noise figure, internal voltages and temperatures. Forward and reverse power. Status from motor, turning unit and optional inputs providing antenna status.
BITE status:	Displays transceiver components status
BITE measurements:	Temperatures. Internal power supplies. Noise figure, indicative power level.

If parameters exceed specifications, warnings or error messages are automatically issued to the various human user interfaces available i.e. both on the control panel on the front of the transceiver and across the LAN interfaces.

3.11.3.1 BITE - errors/warnings

Errors and warnings are used to report the presence of abnormal conditions detected by the transceiver software and include the following information:



Title:	The title of a BITE error/warning is a short text indicating the abnormal condition and/or the transceiver component to which it applies, e.g. "Main fan", "High temperature", etc.
Description:	The description of a BITE error/warning is a text that can be used to provide the system operator with an understanding of the context of the abnormal condition, e.g. "FPGA High Temperature Fatal Error # SP1" indicates that the core temperature of the first FPGA (SP1) on the processing board in slot 1 has exceeded the allowed maximum rating.
Severity:	<p>The severity of a BITE error/warning is used to indicate the impact of the abnormal condition on transceiver operation.</p> <p>There are four categories of severity and beside that warnings:</p> <p>Fatal error, critical error, redundant system critical error and error.</p> <p>A "fatal error" shuts down the system and a "critical error" stops transmission.</p> <p>A "redundant system critical error" causes a failover in a redundant system. In a single system, an error with his severity is treated as severity "error", but will not cause a transmission stop.</p>
Priority:	The priority of a BITE error is used to indicate the relative importance of an error compared to other errors of the same severity.

3.11.3.2

BITE status

These messages indicate the state of transceiver components or entities of importance to the operational state of the transceiver, e.g. TX Status "On"/"Off".

3.11.3.3

BITE measurements

BITE measurements are used to periodically report a numerical measurement in the transceiver and includes the following information: Title, description and value.

Measured parameters include noise figure, forward and reverse power, temperatures, voltages etc. For each measured parameter, configuration of lower limit, upper limit, maximum update interval and precision are defined.

3.11.3.4 BITE logging

Logging of BITE errors and warnings, BITE status and BITE measurements is performed and data is stored in an allocated area of the hard disc on the PC controller board. See Fig. 3.15 (p. 51).

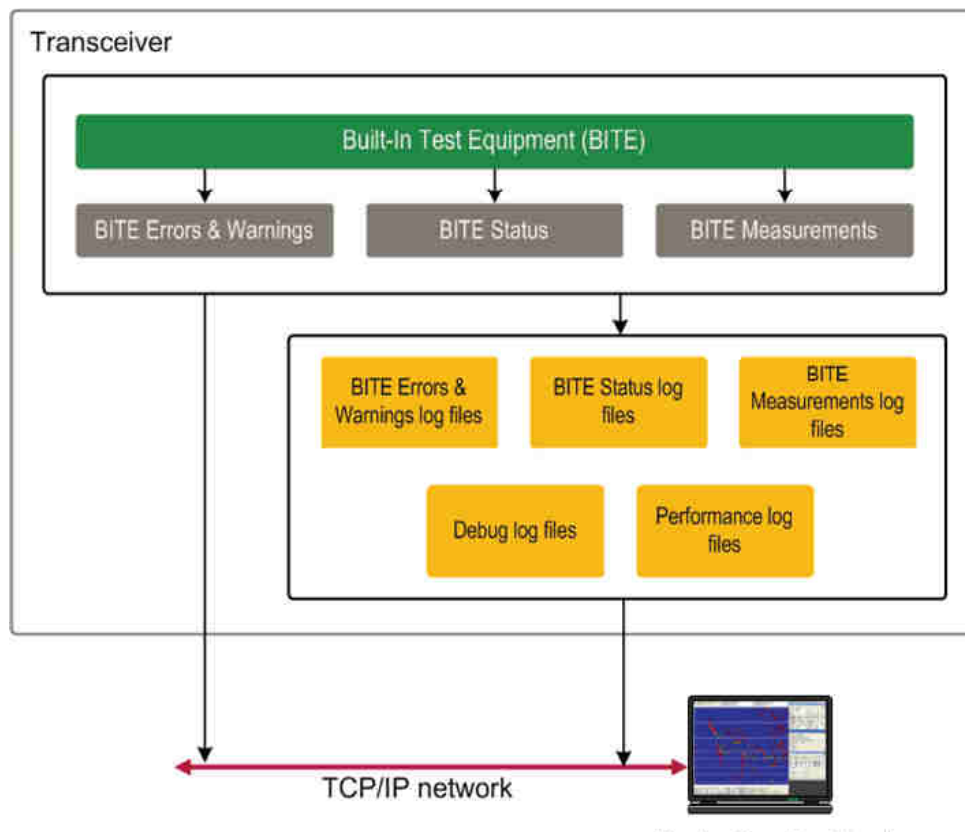

Fig. 3.15 BITE and performance logs

A change log approach is used, meaning that BITE errors, warnings, status and measurements are logged in case of a changed value or a changed state.

Each BITE log and the parameter log store a log file per day. The storage period of log files in these logs can be configured to max. 180 days (default is 90 days).

Furthermore, max. disk size for the three BITE logs can be configured. If the storage period is exceeded, a log file per day will automatically be deleted, starting with the oldest file. If the disk size is exceeded before expiration of the storage period, the oldest log files will be deleted to free space on the disk.

In addition, there is a performance log where performance parameters such as noise figure, forward power, etc. are measured periodically. In this log, files are stored 10 for years (storage period cannot be configured).

Overheating at one or more of the temperature test points will issue a warning or error message and critical overheating will result in automatic shutdown

Automatic shutdown is based on a combination of autonomous HW circuitry and SW-controlled shutdown, based on the BITE system.



The power supply unit includes a mains check functionality (HW) that shuts off the system if the mains input exceeds the specified limits in terms of voltage level and frequency. Furthermore, the unit includes a thermal switch that shuts down in case of a hazardous temperature.

The BITE errors and warnings have a severity property which is used to take action on the BITE errors. One of these actions is to shut down in case of a "Fatal error" e.g. an over-temperature in a unit.

All the BITE and measurements data are remotely available on the proposed maintainer's laptop facility.

True graceful degradation will only be obtained with a redundant system. Some units are based on a design that yields a kind of graceful degradation e.g. the Solid State Power Amplifier with parallel coupled power groups.

The system will, however, be able to run with degraded performance as long as the severity of BITE errors is not "fatal error" or "critical error", as these shut down the system or stops transmission.

4 Hardware modules

4.1 Transceiver building blocks

The transceiver consists of the building blocks shown below, parted up in a radio section and a processing section.

The building blocks are as shown in the following illustration.

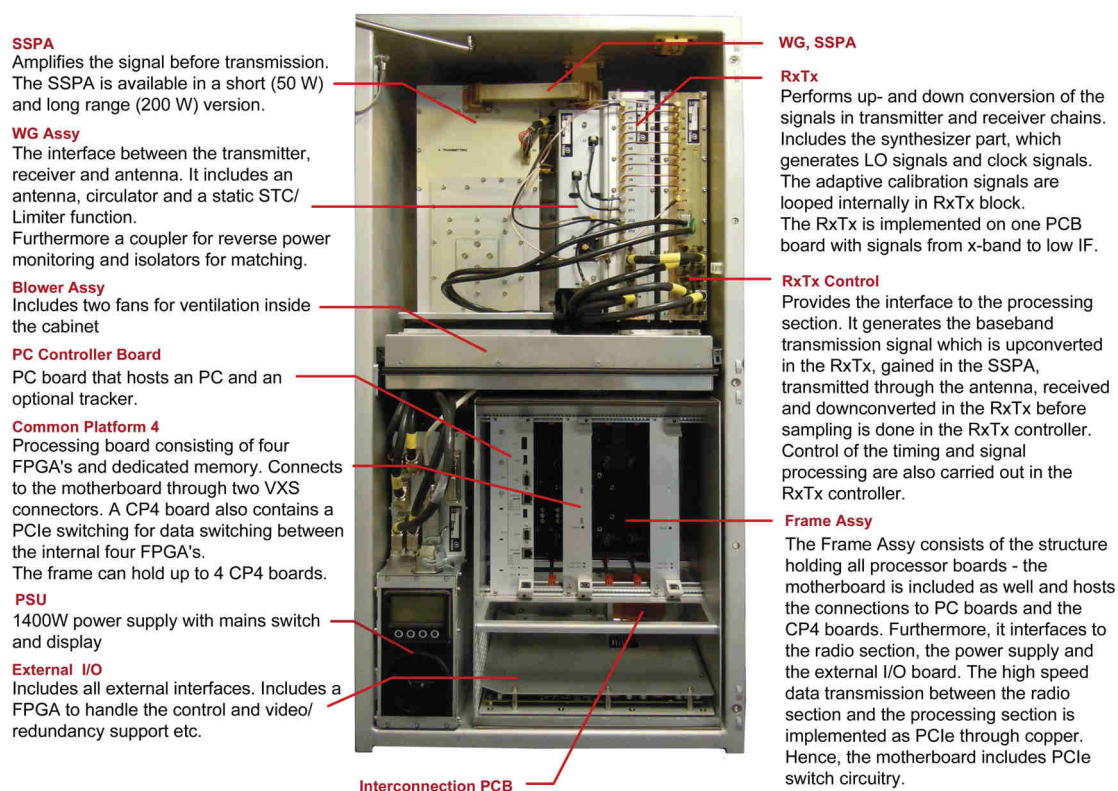

Fig. 4.1 Transceiver building blocks

4.2 Dimensions

The transceiver design and dimensions are outlined below.

All transceiver dimensions can be found in doc. no. 605502-ZD / 605602-ZD.

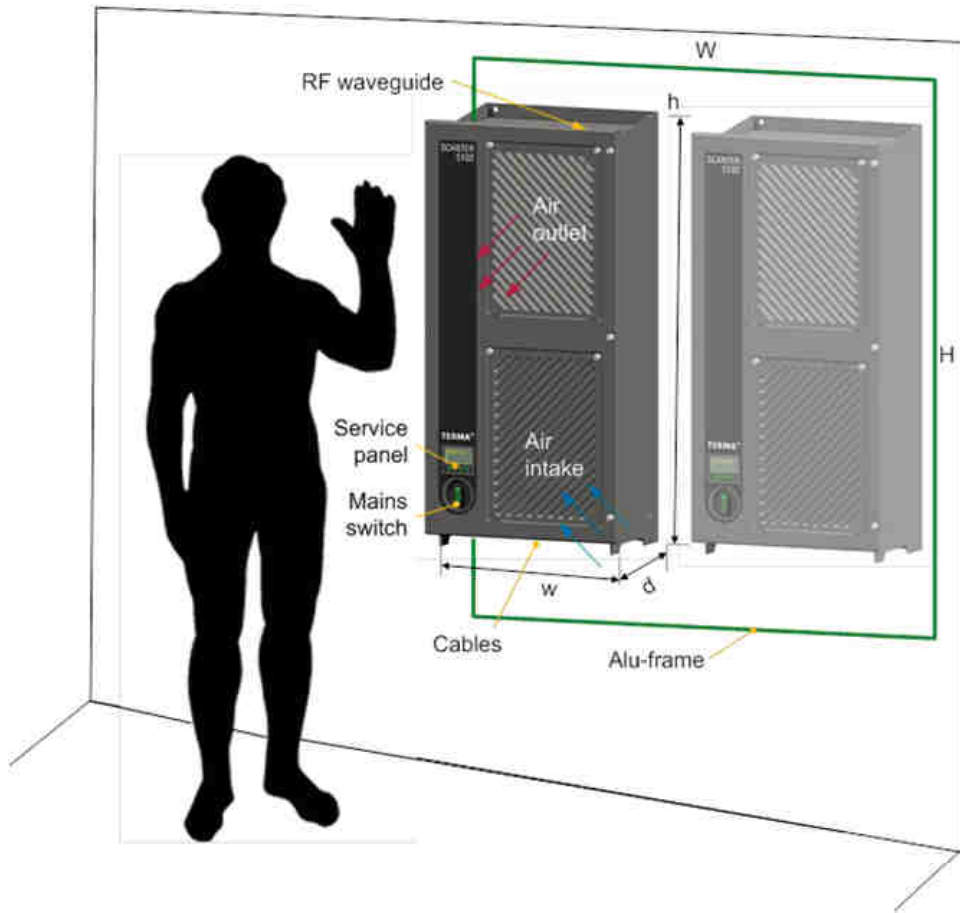

Fig. 4.2 Wall-mounted transceiver dimensions

Weight:	75 kg installed
	115 kg packed for transportation
H x W x D	990 x 497 x 305 mm installed
	~ 610 x 1050 x 660 mm packed for transportation

4.2.1 Transceiver block schematic

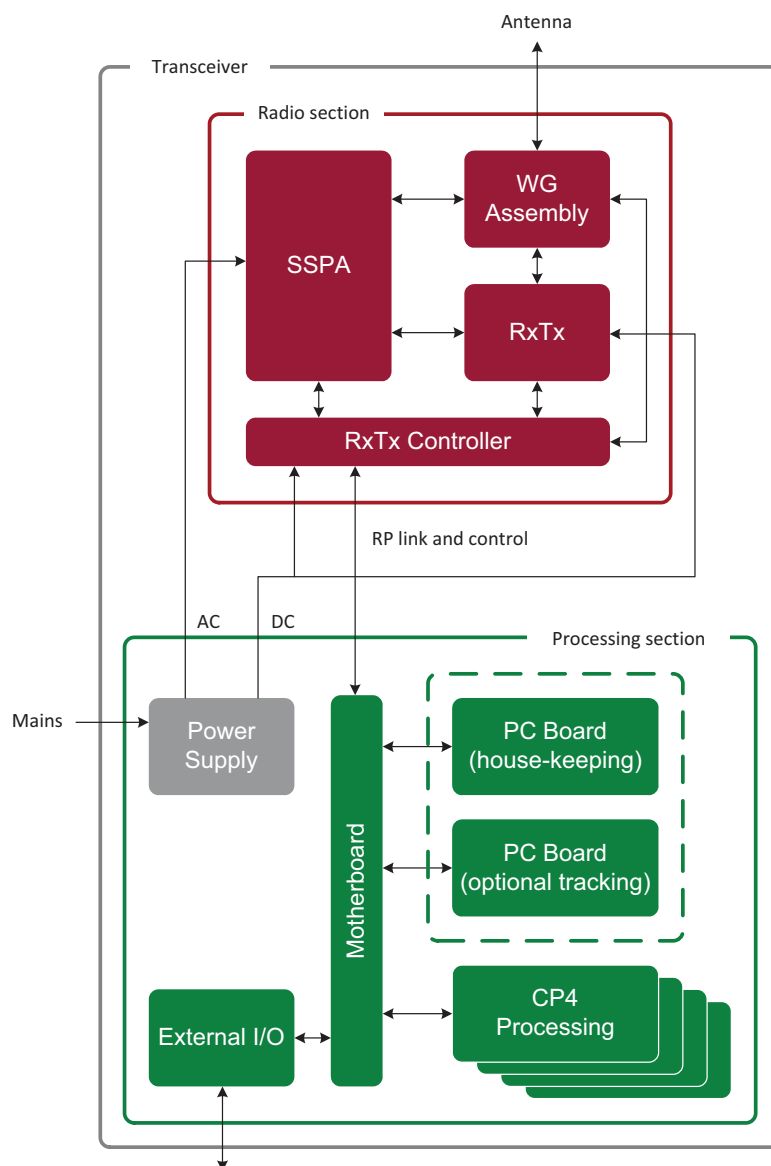

Fig. 4.3 Block schematic

4.2.2 Part numbers, modules

All part numbers for spare parts, consumables and tools are listed in section [7.3 \(p. 112\)](#).



4.3 Hardware structure

4.3.1 Internal cabling

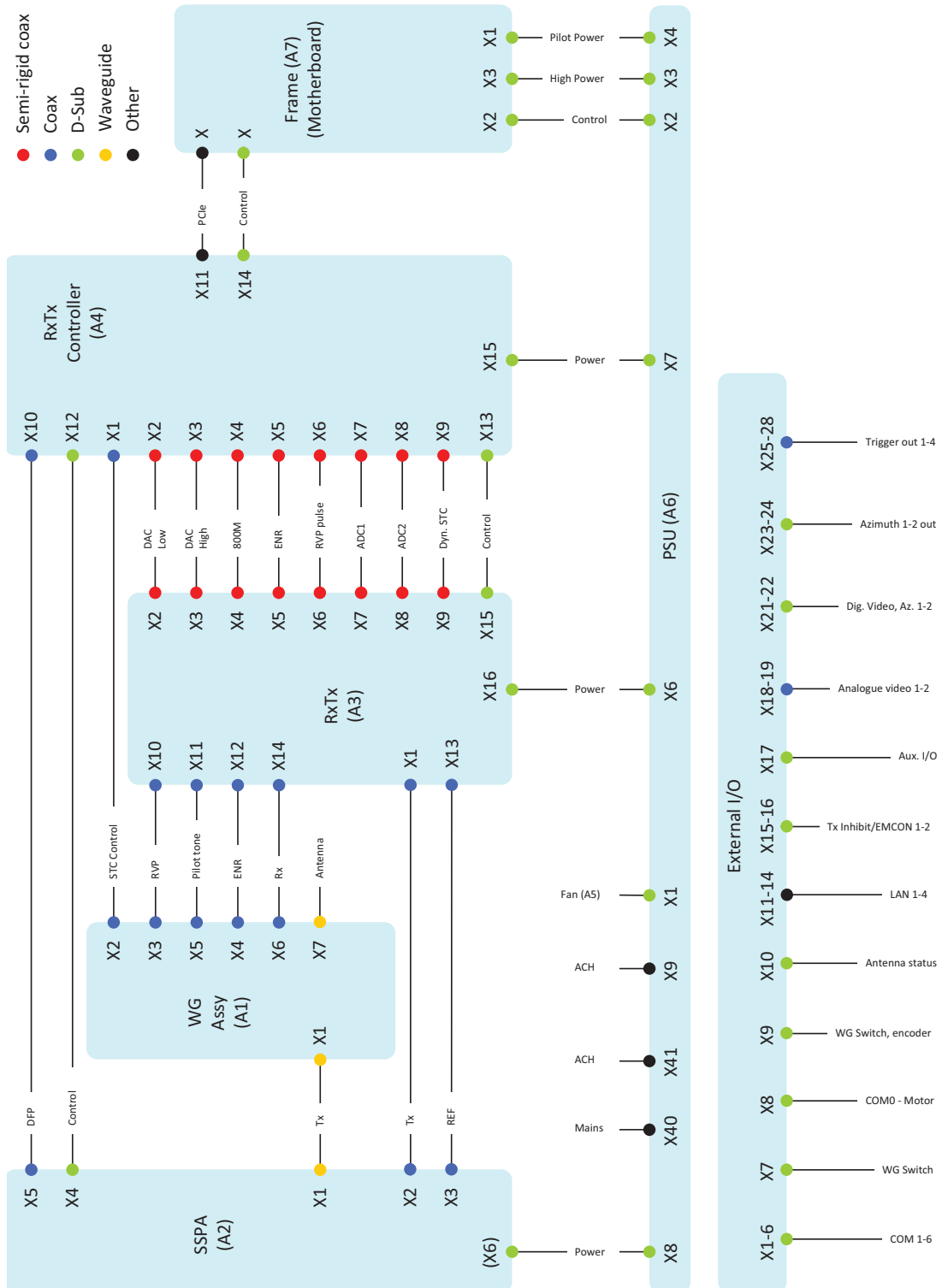

Fig. 4.4 Internal cabling

4.4 Modules

4.4.1 Solid State Power Amplifier (SSPA)

The SSPA (Solid State Power Amplifier) modules for the SCANTER radars are designed on the basis of state-of-the-art MMIC power transistors. See [Fig. 4.5 \(p. 57\)](#).

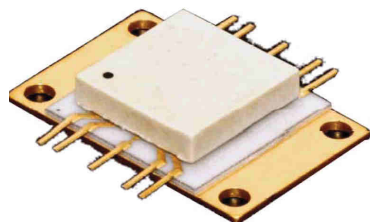

Fig. 4.5 Power transistor

Each power amplifier (PA) module consists of 8 power transistors. The PA amplifies the signal to be transmitted and produces 50 W of microwave power.

The SCANTER 5502 contains one power module, while the SCANTER 5602 contains four modules providing 200 W output power.

The SSPA output power is adjustable in azimuth sectors. The peak output power may be reduced by up to 31 dB.

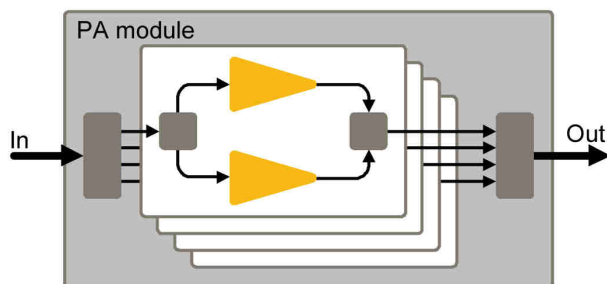

Fig. 4.6 50 W SSPA module

4.4.1.1 SSPA description

The SSPA basically amplifies the pulsed X-band transmission signal from the RxTx to an appropriate power level. The output power level is measured with a logarithmic detector circuit.

The SSPA consists of boards mounted on a common profile. The integrated waveguide power combiner is also integrated in the profile.



Fig. 4.7 SSPA modules - 50 W left and 200 W to the right

Block schematics of the two versions are shown below:

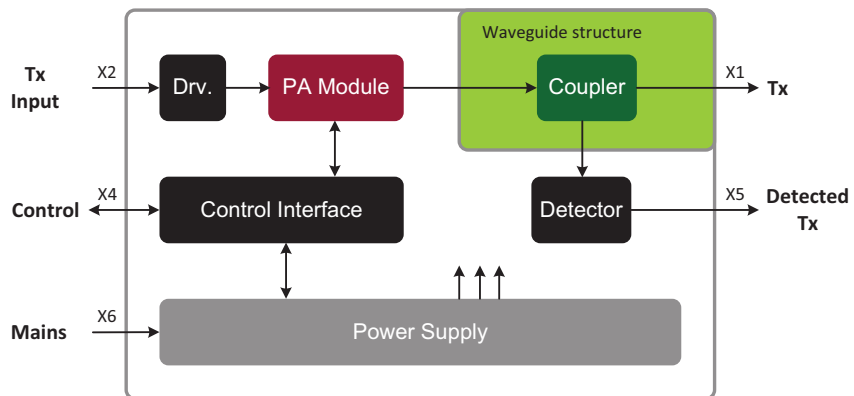

Fig. 4.8 SSPA module block diagram, 50 W

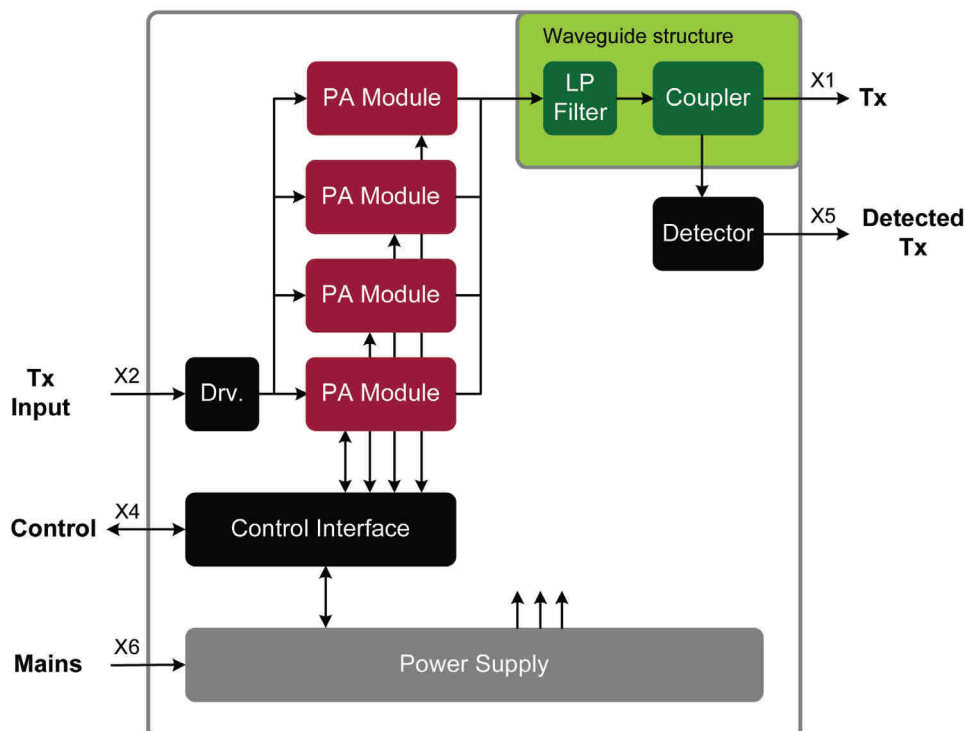

Fig. 4.9 SSPA module, 200 W

Mains from the PSU is connected directly to the SSPA, and an internal power supply in the SSPA is creating all necessary supplies for the module. The local power supply is shown in Fig. 4.10 (p. 59) below. When the safety relay is energized, mains is applied to a filter, rectified and passing a power factor correction before it is applied to three DC/DC converters to generate the final power supplies.

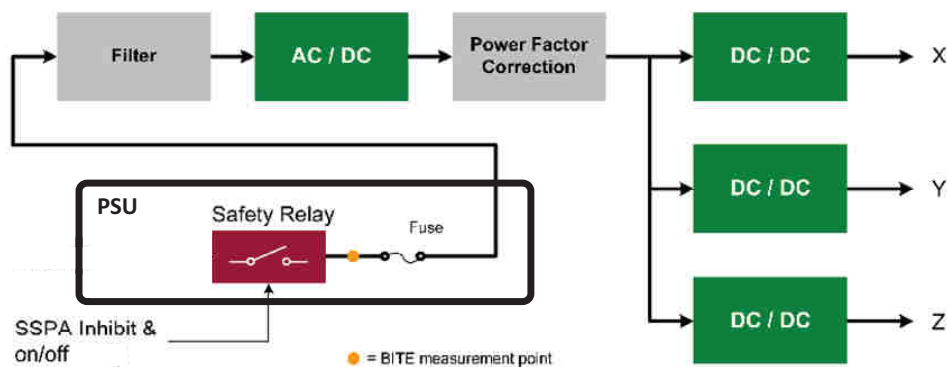

Fig. 4.10 Power Supply, SSPA

A control interface is controlling the output transistors so these are turned on during transmission and turned off during reception. At the same time, the control interface is controlling how many transistors are turned on (and also the phase shift between the transistors); for example, if it is necessary to decrease the power in one or more sectors.

The following information is available:



- Temperature on all PC boards.
- Current consumption on each regulated voltage.
- Voltage level of the most important regulated voltages.
- Status of the negative power supplies on the PA module(s).
- Fault status.

Physical data for the SSPA are as follows:

	SSPA, 50 W
Part number	386255-002
Output peak power	50 W
Power consumption (@ 20% duty cycle)	120 W
Weight	11 kg
Dimensions h x w x d (foot print)	352 x 217 x 189 mm

	SSPA, 200 W
Part number	386250-001
Output peak power	200 W
Power consumption (@ 20% duty cycle)	410 W
Weight	15 kg
Dimensions h x w x d (foot print)	352 x 217 x 249 (227) mm

4.4.1.2 Reliability

There is no need for periodic replacement of Solid State amplifiers as required if using magnetrons or other tube transmitters. In addition, low-voltage power supplies replace the high-voltage supplies needed for magnetron technology. It is therefore commonly assumed that Solid State transmitters are virtually maintenance free and that logistic support is like computer electronics. However, this is not necessarily the case.

Failure mechanisms for high power microwave components are different to those in the computer industry and continuous reliable operation requires dedicated methods during design and operation.

4.4.2 Waveguide Assy

The waveguide assembly is mounted between the SSPA power amplifier and the output flange to the antenna which is located on top of the cabinet. The waveguide assembly includes various test and calibration ports.

Waveguide Assy	Conn.	Function
	X1	Waveguide (SSPA)
	X2	STC Control
	X3	Measurement port
	X4	Test port
	X6	Rx port
	X7	Waveguide (antenna)

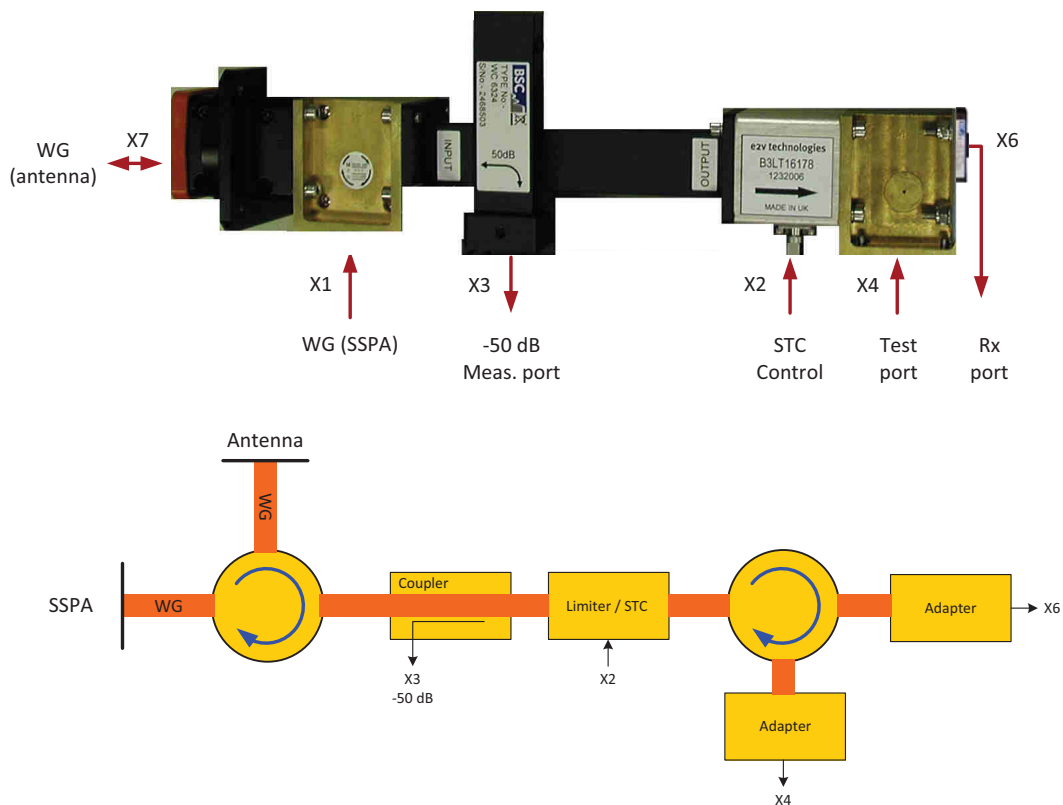

Fig. 4.11 Waveguide assy - block schematic

In the block schematic in Fig. 4.11 (p. 61), the RF signal from the SSPA is applied to a circulator and guided to the antenna.

The received signal from the antenna is applied to the same circulator and guided through a cross coupler where a -50 dB signal is available. After the coupler, the received signal is applied to the Limiter/STC in which attenuation of the signal takes place. The Limiter/STC is able to attenuate the signal with up to 40 dB.

The signal passes a second circulator before it is available for the receiver. Two adapters are mounted on this circulator to change the connections from waveguide flanges to SMA connectors.

4.4.3 RxTx

The RxTx is part of the Radio Section in the transceiver. The RxTx is connected to the RxTx controller and the SSPA. The functionality of the RxTx includes:

- Tx up converter.
- Rx down converter.
- Frequency synthesis circuitry.
- A VCO which provides the local oscillator signals in the Rx and Tx chains.
- A Tx chain attenuator supports TX reduced transmit power in sectors.
- The RxTx provides system clock to the RxTx Controller.
- Measurement system for monitoring noise figure, forward and reverse power.

The position of the RxTx in the system is shown in [Fig. 4.12 \(p. 62\)](#).

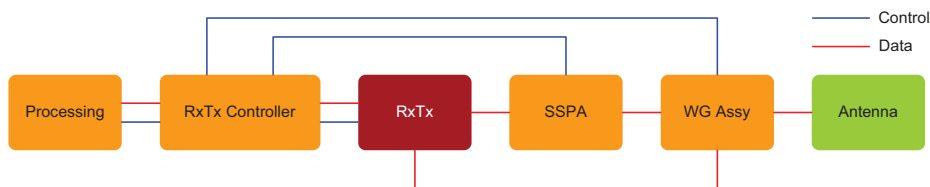



Fig. 4.12 RxTx

RxTx Module	Conn.	Function
	X1	TX out
	X2	Tx input low band
	X3	TX input high band
	X4	800 MHz CTRL
	X5	Noise control
	X6	Rev. Power Env.
	X7	RX ADC1
	X8	RX ADC2
	X9	STC2
	X10	Rev. power in
	X11	Pilot WG
	X12	Noise out
	X13	TX Ref.
	X14	RX in
	X15	Control
	X16	Power

The I/O categories to and from the RxTx are shown in [Fig. 4.13 \(p. 63\)](#).

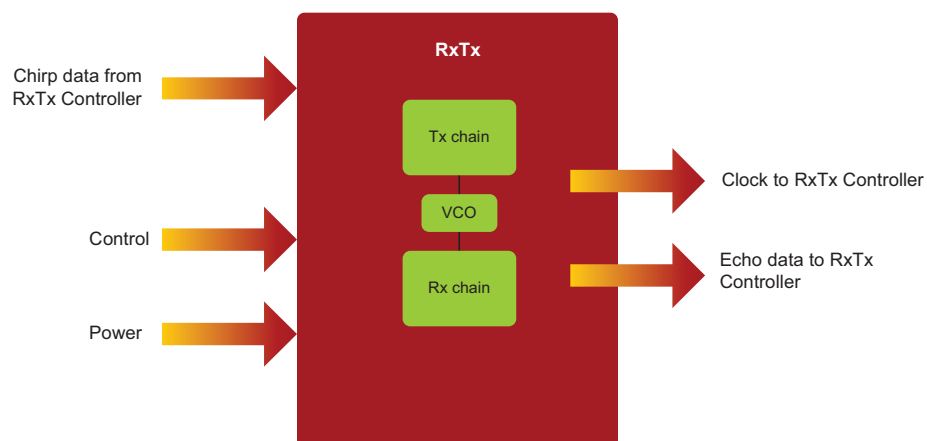

Fig. 4.13 Signal categories to and from RxTx

4.4.4 RxTx Controller

The main tasks of the RxTx controller are:

- Communicate with the processing section via a PCIe interface.
- Generate two channels of chirp signals modulated to a carrier frequency.
- Generate dynamic and static STC.
- Generate a signal for the RxTx noise diode.
- Sample the received radar signal in two channels.
- Sample reverse power.
- Control the RxTx.
- Handle the radar timing sequence and to control the SSPA.

The position of the RxTx controller in the system is shown in [Fig. 4.14 \(p. 64\)](#).

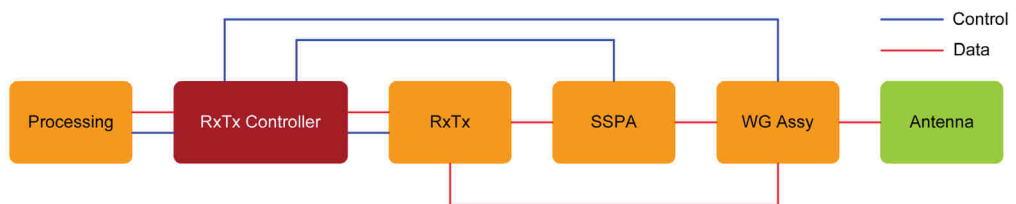
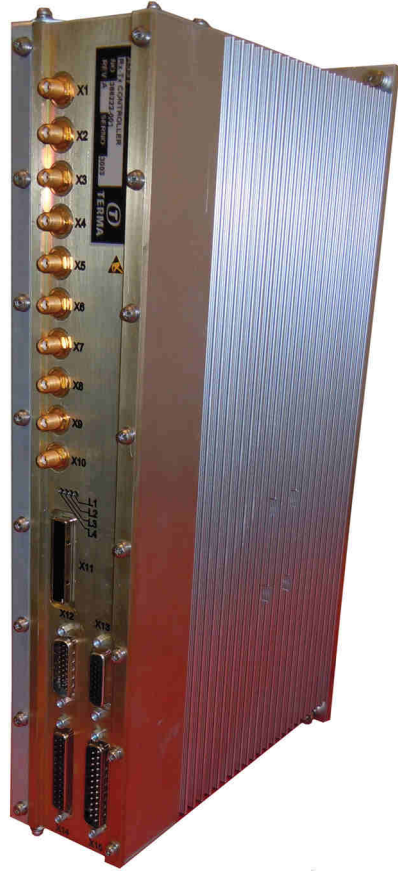

Fig. 4.14 RxTx Controller in the system

RxTx Controller	Conn.	Function
	X1	Static STC output
	X2	Low band
	X3	High band
	X4	Reference Clock
	X5	Noise diode output
	X6	Reverse power input
	X7	Rx echo data input
	X8	Rx echo data input
	X9	Dynamic STC output
	X10	Forward power
	X11	PCIe
	X12	RxTx control
	X13	SSPA control
	X14	Control signals
	X15	Forward power input

The I/O categories to and from the RxTx controller are PCIe, control, power, chirp data to RxTx, echo data from RxTx, transceiver control and transceiver clock as shown in Fig. 4.15 (p. 65).

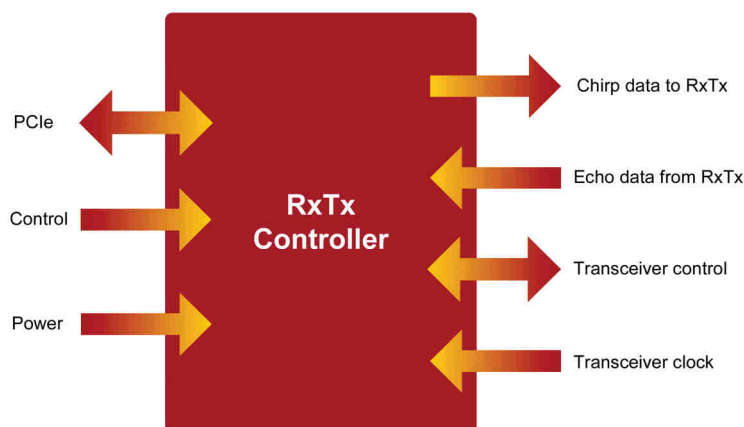

Fig. 4.15 Signal categories to and from RxTx Controller



4.4.5 Blower Assy



Fig. 4.16 Blower assy

4.4.6 Crate Assy incl. Motherboard

The motherboard is a part of the Crate Assy and is one unit - the spare part “Crate Assy” also includes the motherboard.

The motherboard is part of the SCANTER 5502/5602 transceivers processing section. The processing section consists of - besides the motherboard - up to four CP4 processing boards, the External I/O Board, and the PC Controller Board (with up to two PCs on-board).

The motherboard is mounted vertically at the back of the frame. The PC Carrier Board and the CP4 Boards are plug-in modules, mounted in slots in a crate. See [Fig. 4.17 \(p. 67\)](#).

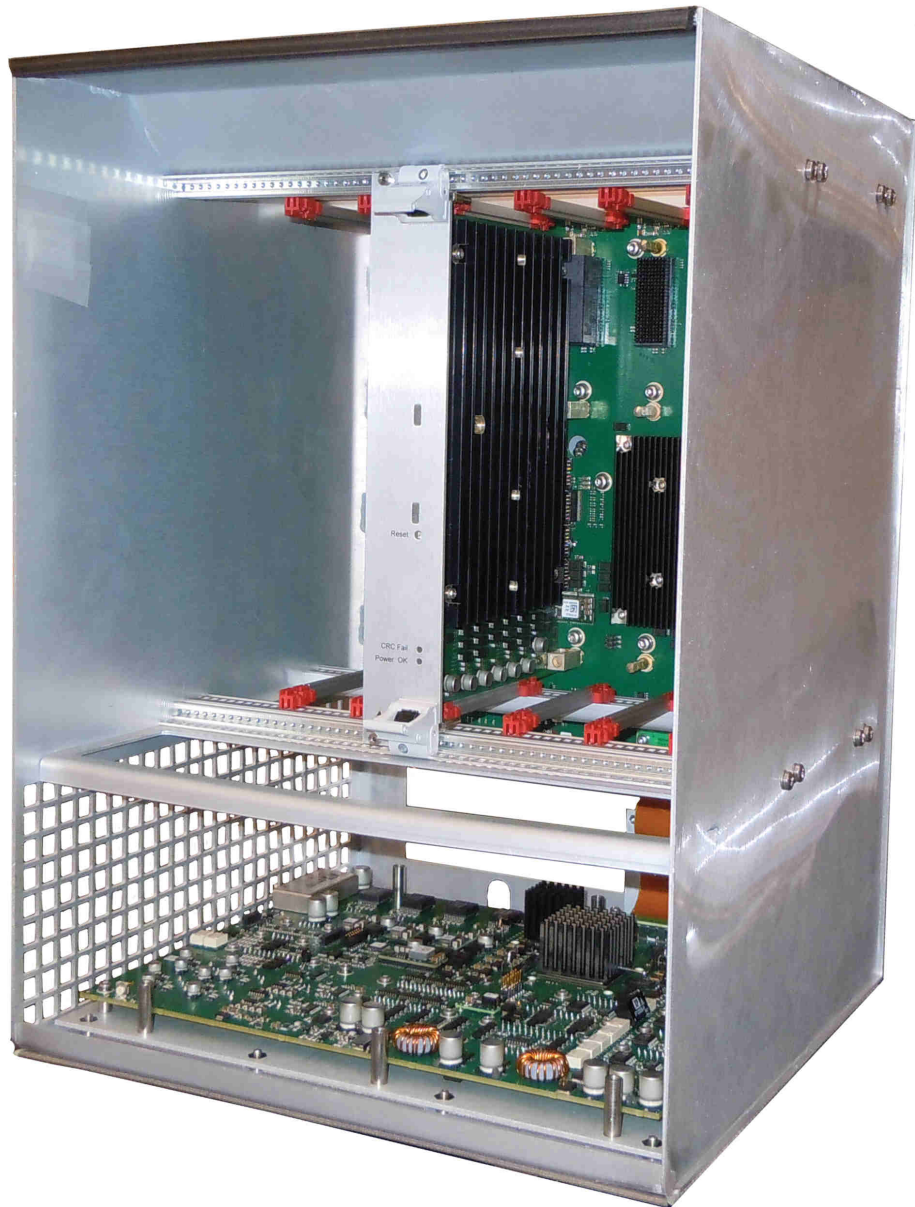

Fig. 4.17 Crate assy, shown with Ext. I/O and a CP4 board

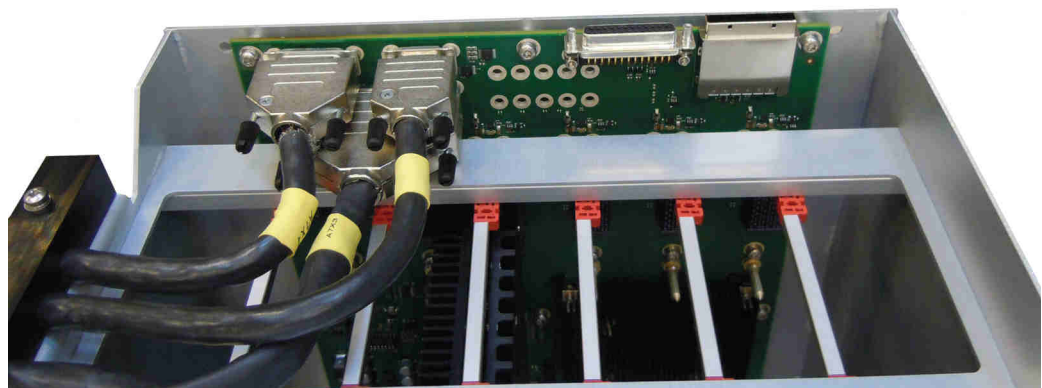

Fig. 4.18 Motherboard and connections shown in crate assy

The block schematic for the motherboard and its peripherals is shown in Fig. 4.19 (p. 68) - the external interfaces are:

- PC Controller board interface (VITA 46.4, PCIe x4 + x4).
- 3 x CP4 interfaces (VITA 46.4, PCIe x8).
- PSU board power (12 V pilot and 12 V).
- PSU board control signals.
- External I/O board power (through Interconnection Board).
- External I/O board control signals (through Interconnection Board).
- External I/O board PCIe x8 (through Interconnection Board).
- RxTx Controller control signals.
- RxTx Controller PCIe x8.
- 1 x USB interface (through Interconnection Board).
- JTAG.

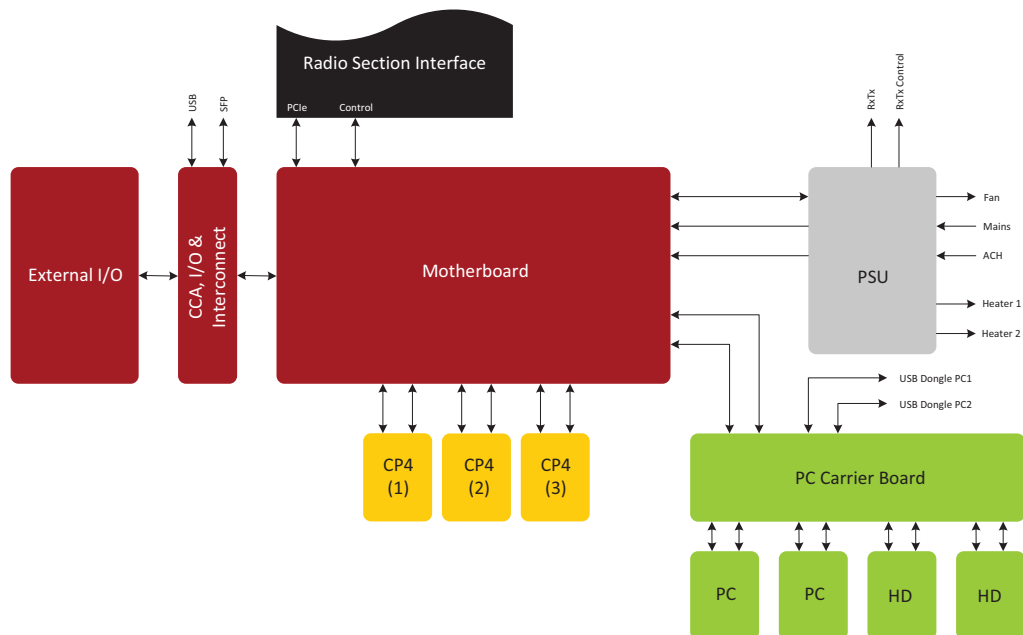

Fig. 4.19 Motherboard and surrounding units

The motherboard uses the VITA 46 keying system. This prevents a plug-in module from being inserted into a wrong slot. The keying system consists of three alignment keys in each slot position. Each key has five different angular positions.

There are six different keying devices for the plug-in modules: five that match each of the allowed angles of the backplane keying pin plus one type which allows the plug-in module keying device to be mated with the backplane pin, no matter the angle (an un-keyed module).

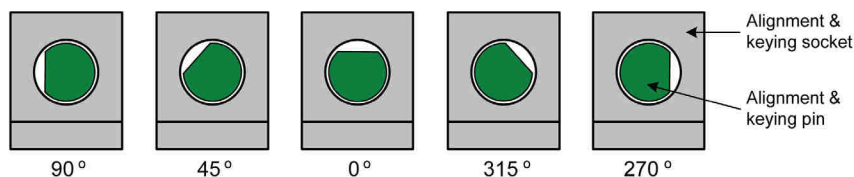

Fig. 4.20 Keying of modules

The PC Controller board has a 315° keying and the CP4 boards have a 0° keying.

4.4.7 PC Controller Board

The PC Controller Board contains two PC Boards, two SSD, two RJ45 connectors for LAN interface, EEPROM, battery holders, JTAG connector, two USB connectors for onboard memory sticks, two USB connectors for keyboard and mouse interface, and two VGA connectors.



Fig. 4.21 PC Controller Board

The PC Controller Board is based on a medium performance processor. It comprises the PCIe root complex, handles the PCIe initialization and uses the PCIe bus to upload new firmware to CP4 boards, External I/O Board, and the RxTx Controller. Furthermore, it also controls the display, the push buttons, the BITE system and initializes the processing in the CP4 boards and RxTx controller.

On the PC Controller Board, a battery takes care of supply to the real time clock on the two PC boards. Battery type is Varta Lithium, size CR 1/2AA. The battery capacity is 950 mAh.

The battery needs to be replaced after 7 years.

4.4.8 Common Platform 4 (CP4) Board

The crate in the transceiver can hold four Common Platform 4 (CP4) boards - the task of the CP4 board is to process the video coming from the RxTx controller and depending on the required processing 1 to 4 boards can be mounted. The boards are connected to the RxTx Controller module with a PCIe bus.

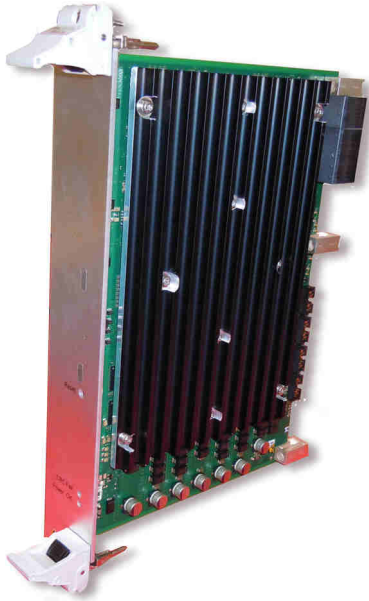

Common Platform 4 Board	Front	Function
	Reset	The cut-out in the middle of the front plate gives access to a reset button.
	Power OK	A green LED on the front tells that power to the board is OK.
	Fail	A red LED indicates that an error has occurred.

The CP4 board consists mainly of four Field Programmable Gate Arrays (FPGA) which take care of all signal processing - each FPGA having its own memories, SDRAM, SRAM and Flash.

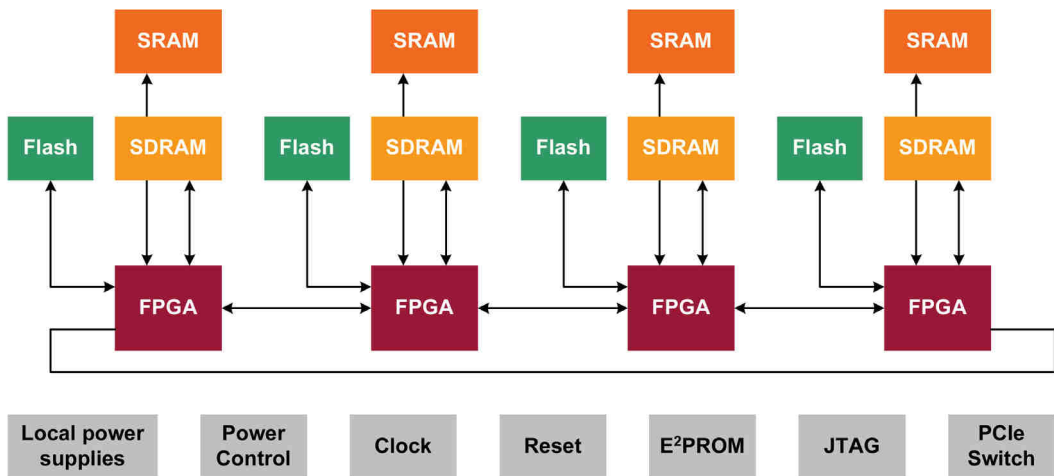

Fig. 4.22 CP4 board, block schematic

The board produces its own local power supplies, based on +12 VDC.

4.4.9 Power Supply Unit (PSU)

The power supply unit, located in lower left corner of the cabinet, supplies all modules in the transceiver - the SSPA is applied and is generating its own local supplies.

Beside the power supplies, the PSU has a local BITE circuit to measure voltages and temperatures and it also holds - on the front - a display, a mains switch, and four push buttons for human interface to the transceiver and for status indication.

4.4.9.1 Connections

Power Supply Unit	Conn.	Function
	X1	Fan and pressure sensor
	X2	Motherboard, control signals
	X3	Motherboard, high power
	X4	Motherboard, pilot power
	X6	RxTx, power
	X7	RxTx Controller, power
	X8	SSPA, AC power
	X9	ACH, AC power (optional) Heater, power (optional)
	X40	Mains, AC power
	X41	ACH, AC power (optional)

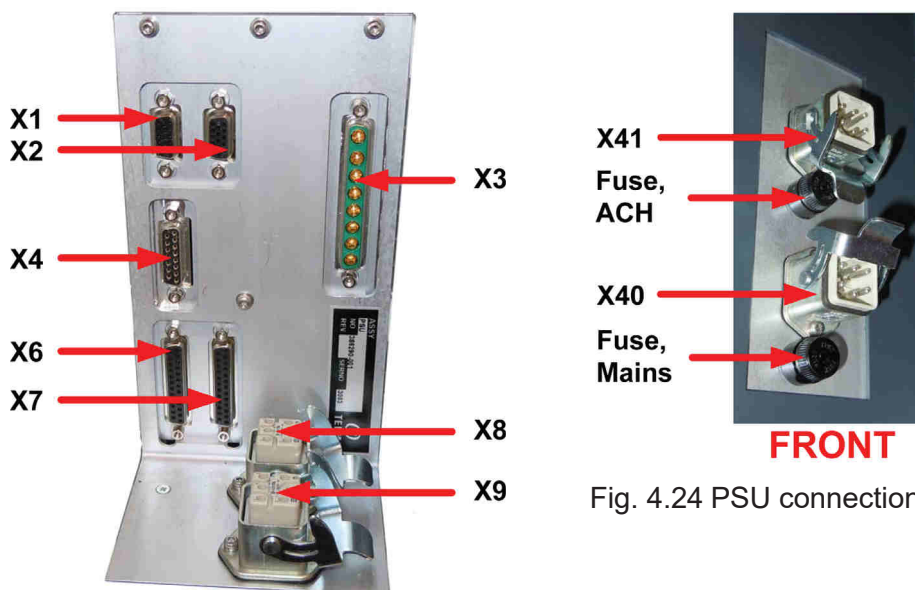

Fig. 4.23 PSU connections, top

Fig. 4.24 PSU connections, bottom

4.4.9.2 Block Schematic, Supplies

Referring to [Fig. 4.25 \(p. 72\)](#), mains is applied - when turning the mains switch on and presuming the fuse is not blown - to a relay controlled by a circuit which is checking the mains supply and the temperature in the PSU. This means, if some limits are exceeded, it will not be possible to turn on the transceiver (if the temperature is below 0° C, the heater will be turned on and in that way ensure temperatures above 0° C).

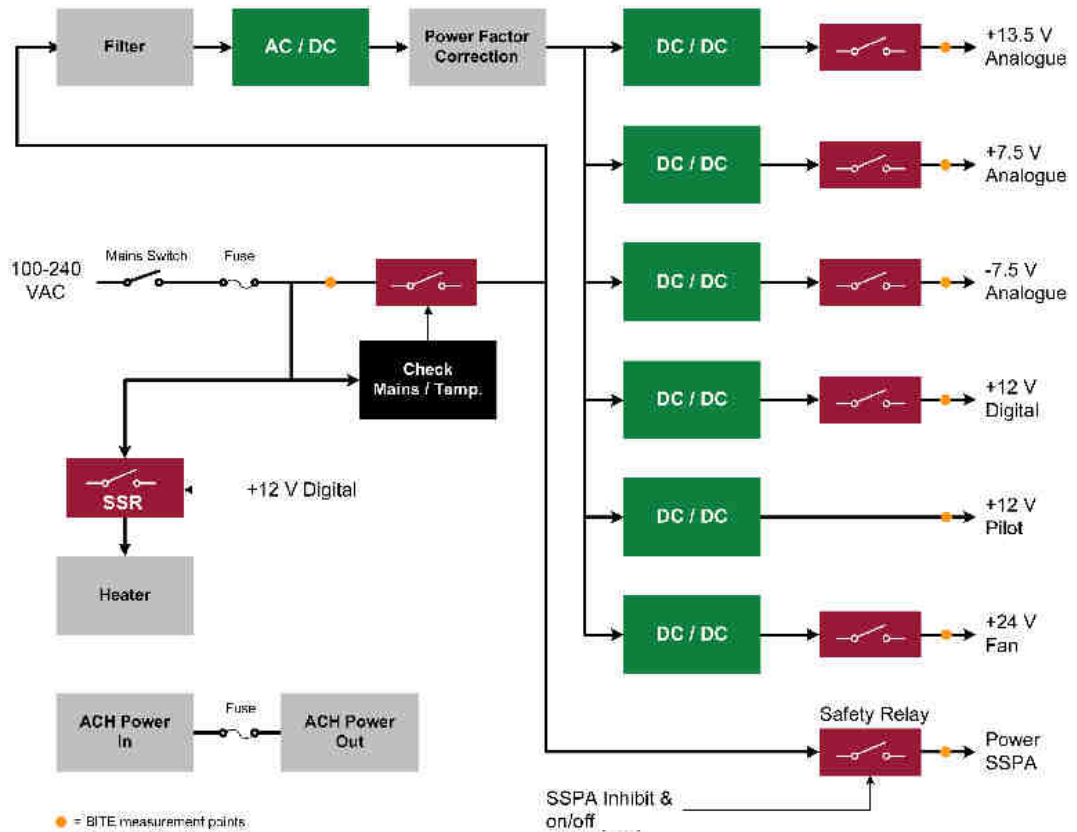

Fig. 4.25 Block schematic, supplies, PSU

The limits are:

Parameter	Minimum	Maximum
Temperature in PSU	0° C/ 32° F	85° C/ 185° F
Mains voltage	90 VAC	264 VAC
Mains frequency [Hz]	47 Hz	63

Not exceeding the above mentioned limits, mains is applied to the SSPA module (which produces its own supplies) and to the mains filter. The filter ensures that no noise is radiated back to mains and at the same time it reduces spikes that may be in the mains supply voltage.

After having passed an AC/DC converter and a Power Factor Correction circuit, a DC voltage is applied six DC/DC converters, which are producing all necessary DC voltages. The voltages will not be present at the connected modules before the relay is energized. Only the +12 V Pilot is available all the time as this supply voltage is used to wake up the display, giving the possibility to start up the transceiver.

The power consumption for each supply voltage (for a fully equipped transceiver, (i.e. two PCs and 5 CP4 modules) is shown in the following table.

Supply voltage	Approx. power [W]
Mains, AC (SSPA module)	450
+13.5 V (RxTx)	47
+12 V (RxTx Control, 5 x CP4, 2 x PC)	420
+7.5 V (RxTx, RxTx Control)	31
-7.5 V (RxTx, RxTx Control)	6
+12 V Pilot (Motherboard, I/O, 2 x PC)	126
+24 V (Fan)	41

4.4.9.3 Block Schematic, SPI and I2C buses

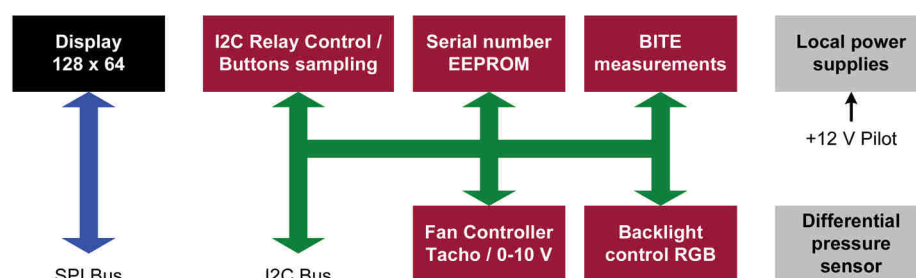

Fig. 4.26 Block schematic, SPI and I2C buses, PSU

Apart from the generation of power supplies, the PSU also includes a processor-based part to take care of the human interface, BITE logic and fan control.

This part produces local supplies based on the +12 V Pilot. Furthermore, there is a circuit to monitor the pressure out of the fan (a differential measurement to monitor the air flow).

An SPI bus controls the 128 x 64 display, while an I2C bus connects functions as BITE measurement, control of the backlight color in the display, detection of activated buttons, fan speed monitoring, and control of relays in the PSU.



4.4.9.4 Operator's Panel

The display has several functions:

Read-out of errors and warnings.

The bottom line of the display dedicates functions to the four software definable keys just below the display.

The backlight of the display tells about transceiver status:

Cold blue backlight indicates that the transceiver is booting.

Red backlight indicates errors or warnings.

Yellow backlight indicates warnings.

Green backlight indicates that everything is running OK.

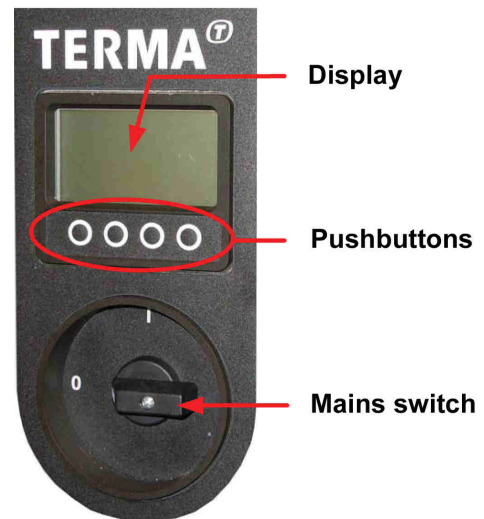

Fig. 4.27 Display and buttons

Each push button is located inside a white ring. The ring has a light green backlight to indicate physical position in darkness.

The functions of the buttons are determined by the text in the display (software defined). Typical functions are “Left” and “Right” to navigate between the menus, and “Select” and “Exit” to navigate up and down in the menu hierarchy.

The mains switch is placed below the four push buttons and is used to switch ON or OFF.

4.4.10 External I/O Board

The External I/O Board handles all communication going to and from the radar. It provides radar video on LAN, digital video, and control and timing signals to external Terma equipment or external third party equipment.

The External I/O Board hosts the connections for all external access to the SCANTER 5502/5602 transceivers. This includes LAN video, digital video, analog video, antenna rotation data, man aloft switch, ACU, GPS, meteorological system and miscellaneous communication interfaces such as RS-485, RS-232, RS422, and LAN.

All connections are accessible at the bottom of the cabinet. The I/O Board is supplied from the motherboard with +12 V Digital and produces itself necessary local supplies.

All inputs and outputs of the I/O Board are controlled by a FPGA with an included UART.

4.4.10.1 Connections

Note: The listed connections are indicative. For latest updates and further details, refer to doc. no. 386300-DI.

External I/O Board	Conn.	Function
	X1-X4	COM 1-4 (COM 1 not connected)
	X7	Waveguide switch
	X8	Motor Communication, COM 0
	X9	Waveguide switch and Encoder
	X10	Antenna status
	X12 - X14	LAN 1-3 (LAN 1 not connected)
	X15 - X16	Tx Inhibit / EMCON
	X17	Aux I/O
	X18 - X19	Analog Video Output
	X21 - X22	Digital Video and Azimuth Output
	X23 - X24	Azimuth Output
	X25 - X28	Trigger Output

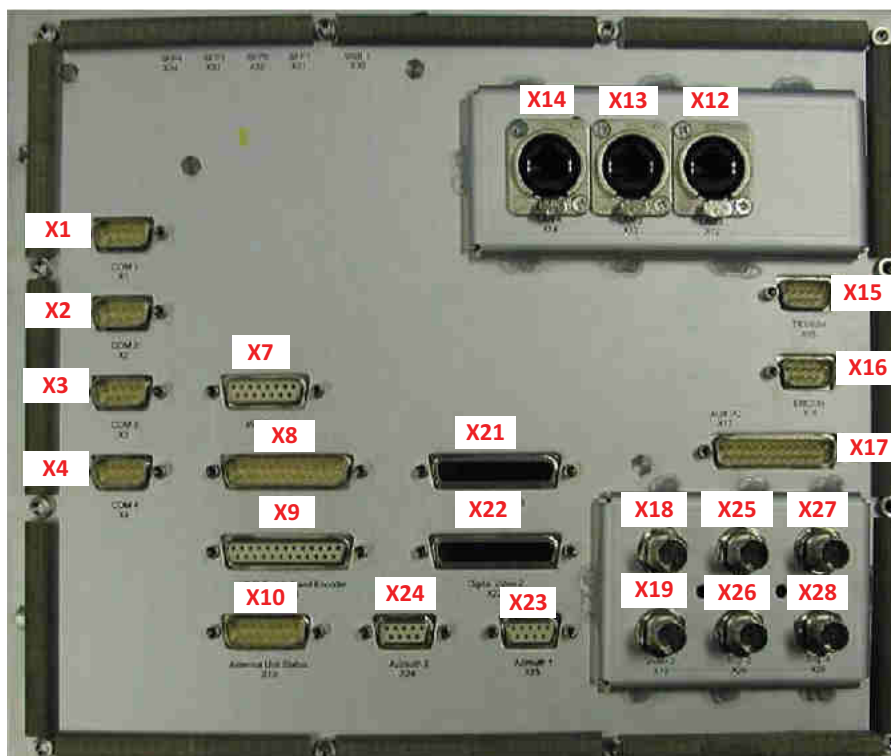

Fig. 4.28 External I/O, connections

4.4.10.2 X1-X4, COM 1-4

The serial communication is galvanic isolated. The protocol can be selected as RS422 or RS232. The default protocol is RS422.



Description	Data or Settings
Communication speed	1200 - 115200 bps
Interface standard	RS422 or RS232, galvanic isolated
Bit Rate	1200, 2400, 4800, 9600, 19200, 38400, 57600 or 115200 baud
Data bits	8
Parity	No, Even or Odd
Stop bits	1 or 2
Connector	D-Sub 9, male

Terminal	Function RS232	Function RS422
1	NC	Transmit data Tx+
2	Transmit data TxD	Transmit data Tx-
3	Receive data RxD	Receive data Rx+
4	NC	Receive data Rx-
5	Return 0 V	Return 0 V
6	NC	NC
7	NC	NC
8	NC	NC
9	NC	NC

4.4.10.3 X7, WG Switch

X7, Waveguide Switch, can be used to control a switch in the antenna or in a redundant configuration. The outputs are short circuit protected (3 Amps.).

Description	Data or Settings
Number of outputs	1
Waveguide switch signal	+28 V \pm 1 V
Tell back signal	+24 V +1/-2 V
Output	Relay output 28 VDC. Pulse 2 sec. Diode protected. Max. 3 A.
Connector	D-Sub 15, female

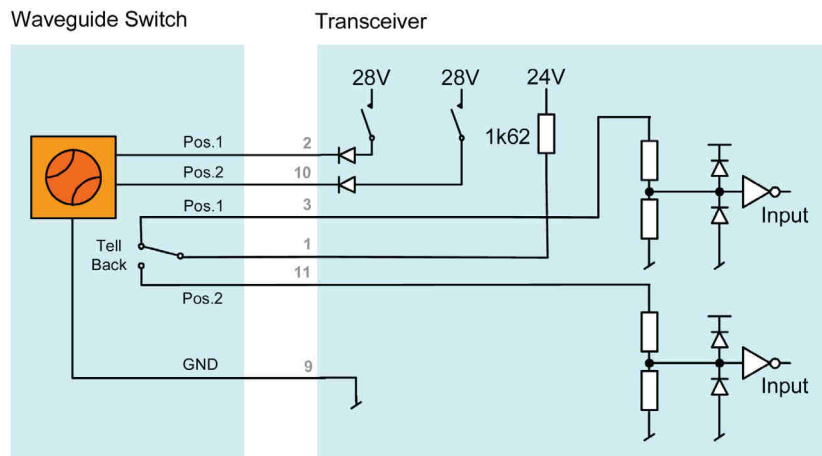

Fig. 4.29 Waveguide switch X7

Terminal	Function	Terminal	Function
1	24 VDC output	9	GND
2	Position 1	10	Position 2
3	Tell back position 1	11	Tell back position 2
4	NC	12	NC
5	NC	13	NC
6	NC	14	NC
7	NC	15	NC
8	NC		

4.4.10.4 X8, Motor Communication, COM 0

X8 includes serial communication to the motor controller, antenna ON signal and the safety loop.

Description	Data or Settings
Communication speed	1200 - 115200 bps
Interface standard	RS485, galvanic isolated
Format	RS485, balanced line, baud 9600, 8 bits, no parity, 2 stop bits $\frac{1}{2}$
Safety loop	External switch
Connector	D-Sub 25, male



Terminal	Function	Terminal	Function
1	+24 VDC	14	ACU fault p. 2 (safety loop)
2	ACU fault p.1 (safety loop)	15	RS485-
3	RS485+	16	NC
4	RS485 common	17	Motor start pin 2
5	Motor start pin 1	18	Motor start pin 4
6	Motor start pin 3	19	NC
7	NC	20	NC
8	NC	21	NC
9	NC	22	NC
10	NC	23	NC
11	NC	24	NC
12	NC	25	NC
13	NC		

4.4.10.5 X9, Waveguide Switch and Encoder

X9 includes more than one function as it interfaces to a waveguide switch and the encoder.

The output for waveguide switch can be used to control the polarization switch in the antenna. The connector includes supply for the encoder (one per transceiver) and the encoder data.

Description	Data or Settings
Waveguide Switch:	
Number of outputs	1
Waveguide switch signal	+28 V \pm 1 V
Tell back signal	+24 V +1/-2 V
Output	Relay output 28 VDC. Pulse 2 sec. Diode protected. Max. 3 A.
Connector	D-Sub 25, female (shared with encoder data)
Encoder:	
Antenna rotation rate	Up to 60 RPM
Pulses per revolution	ACPs: 4096 or 8192, ARP: 1

Description	Data or Settings
Pulse width, ACPs and ARP	> 10 μ s
Format	RS422A, balanced line
Encoder supply	+5 V adjustable. 5-7 VDC, max. 1 A.
Connector	D-Sub 25, female (shared with WG Switch)

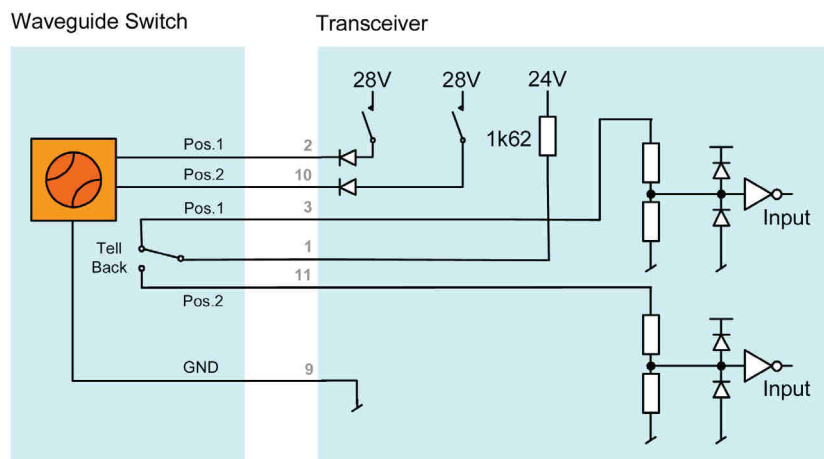

Fig. 4.30 Waveguide switch X9

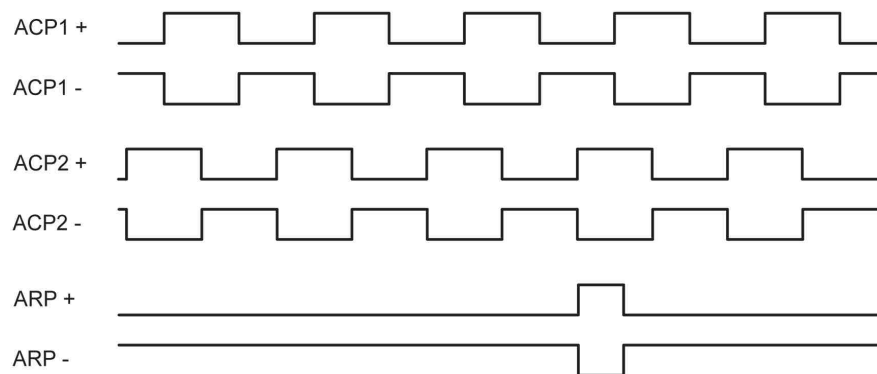
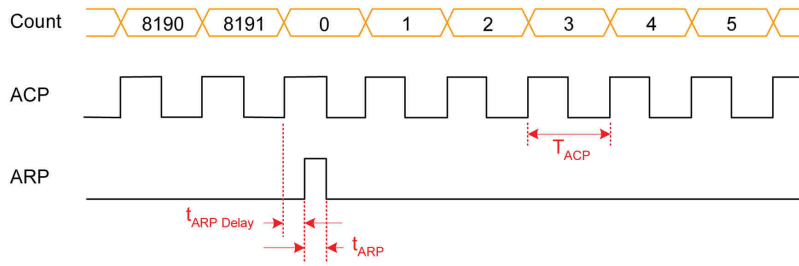

Fig. 4.31 Waveforms measured relative to GND. Antenna rotation CW



$$T_{ACP} = \frac{60}{\text{Antenna RPM} \times \text{Encoder pulses}}$$

$$t_{ARP\ Delay} = 0.25 \times T_{ACP}$$

$$t_{ARP} = 0.25 \times T_{ACP}$$

Fig. 4.32 Azimuth timing

Terminal	Function	Terminal	Function
1	Encoder ACP2+ input	14	Encoder ACP2- input
2	Encoder ARP+ input	15	Encoder ARP- input
3	Power supply for encoder	16	Encoder power return. 0 V
4	Encoder ACP1+ input	17	Encoder ACP1- input
5	NC	18	NC
6	NC	19	NC
7	NC	20	NC
8	NC	21	NC
9	NC	22	Tell back, position 1
10	24 VDC output	23	Tell back, position 2
11	24 VDC output	24	GND
12	Position 1, WG switch	25	GND
13	Position 2, WG switch		

4.4.10.6 X10, Antenna Unit Status

Signals from X10 include motor status, antenna gearbox status and safety loop status. The man aloft switch, which is a part of the safety loop, is included as well.

Description	Data or Settings
Interface	15 mA current loop
Loop resistance	Max. 100 Ohms
Motor temperature warning	External switch - normally closed
Oil level warning	External switch - normally closed
Oil temperature warning	External switch - normally closed
Motor protection (safety loop)	External switch - normally closed
Man aloft switch (safety loop)	External switch - normally closed
Connector	D-Sub 15, male

Terminal	Function	Terminal	Function
1	24 VDC	9	GND
2	Oil temperature warning	10	Motor temperature warning
3	Oil level warning	11	Reserved
4	Motor protection pin 1 (safety loop)	12	Motor protection pin 2 (safety loop)
5	Man aloft switch pin 1 (safety loop)	13	Man aloft switch pin 2 (safety loop)
6	NC	14	NC
7	NC	15	NC
8	NC		

4.4.10.7 X12-X14, LAN 1-3

For video and control interfaces, refer to SCANTER LAN video protocol.

Description	Data or Settings
Interface standard	Ethernet standard IEEE 802.3 10 / 100 / 1000 Base-T
Connector	RJ-45 Jack 8, with or without NEUTRIK NE8MC enclosure

Terminal	Function	Terminal	Function
1	BI_DA+	6	BI_DB-
2	BI_DA-	7	BI_DD+
3	BI_DB+	8	BI_DD-
4	BI_DC+	SHELL	Shield
5	BI_DC-		

4.4.10.8 X15-X16, Tx Inhibit / EMCON

The two Tx Inhibit/EMCON inputs are hardware-controlled inhibit functions of the RF transmitter. Both inputs have a software tell back function.

Description	Data or Settings
Number of inputs	2
Tx Inhibit / EMCON input	External contact to GND. Max. 25 VDC when open. Max. 15 mA when closed.
Connector	D-Sub 9, male

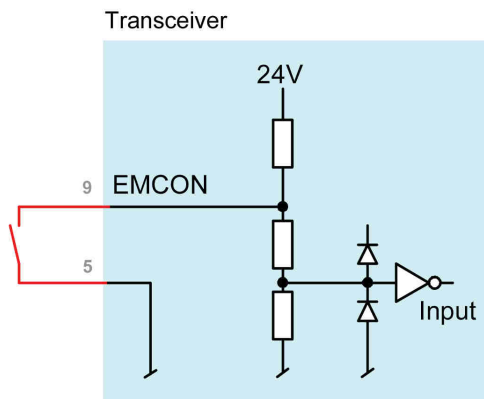

Fig. 4.33 Input circuit for Tx Inhibit

Terminal	Function	Terminal	Function
1	NC	6	NC
2	NC	7	NC
3	NC	8	NC
4	NC	9	Inhibit input
5	GND		

4.4.10.9 X17, Aux. I/O

To control or monitor external equipment, 4 inputs and 1 output are available. The outputs are floating relay contacts.

The inputs sense a short circuit to AUX 0 V.

Description	Data or Settings
AUX input	External contact between AUX IN and AUX 0 V. Max. 25 VDC when open. Max. 15 mA when closed.
AUX output	Neutral contact. Max. 100 V, 1 A, 50 VA.
Connector	D-Sub 25, male

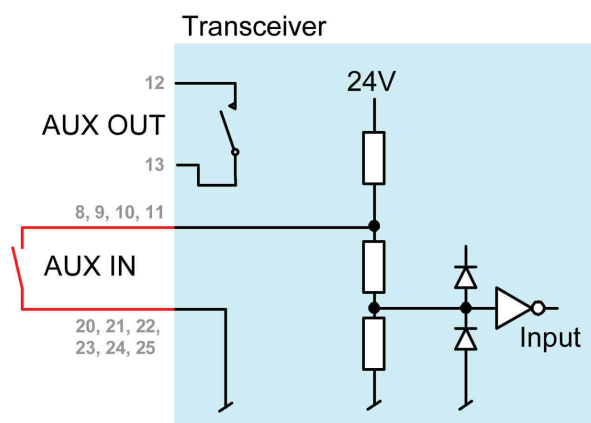

Fig. 4.34 Input circuit, AUX inputs/output

Terminal	Function	Terminal	Function
1	NC	14	NC
2	NC	15	NC
3	NC	16	NC
4	NC	17	NC
5	NC	18	NC
6	NC	19	NC
7	NC	20	AUX 0 V
8	AUX1 IN	21	AUX 0 V
9	AUX2 IN	22	AUX 0 V
10	AUX3 IN	23	AUX 0 V
11	AUX4 IN	24	AUX 0 V



Terminal	Function	Terminal	Function
12	AUX1 OUT	25	AUX 0 V
13	AUX1 OUT		

4.4.10.10 X18-X19, Analogue Video Output 1-2

Description	Data or Settings
Number of outputs	2
Level	0-1 V _{peak} @ 50 Ohm nominal load, DC-level less than 0.05 VDC, or 0-5 V _{peak} @ 75 Ohm nominal load, DC-level less than 0.5 VDC. Levels are individually selectable for each output.
Connector	50 Ohm BNC

4.4.10.11 X21-X22, Digital Video and Azimuth Output 1-2

Description	Data or Settings
Number of outputs	2
Video resolution	8 bits
Format	12 x differential lines: 8 bit data, 1 D_En, 1 clock and 2 status bits EIA-644 (LVDS), max. 50 MHz output data rate
Video type	NR Ch. A, NR Ch. B, MTI selectable
Data rates available	12.5 MHz, 25 MHz and 50 MHz, selectable
Connector	D-Sub 44 HD, female

1	GND	16	GND	31	GND
2	ARP-	17	ARP+	32	GND
3	ACP-	18	ACP+	33	GND
4	Status1-	19	Status1+	34	GND
5	Status0-	20	Status0+	35	GND
6	Data_En-	21	Data_En+	36	GND
7	Clock-	22	Clock+	37	GND
8	Data7-	23	Data7+	38	GND

9	Data6-	24	Data6+	39	GND
10	Data5-	25	Data5+	40	GND
11	Data4-	26	Data4+	41	GND
12	Data3-	27	Data3+	42	GND
13	Data2-	28	Data2+	43	GND
14	Data1-	29	Data1+	44	GND
15	Data0-	30	Data0+		

Digital video timing is shown on the following drawing.

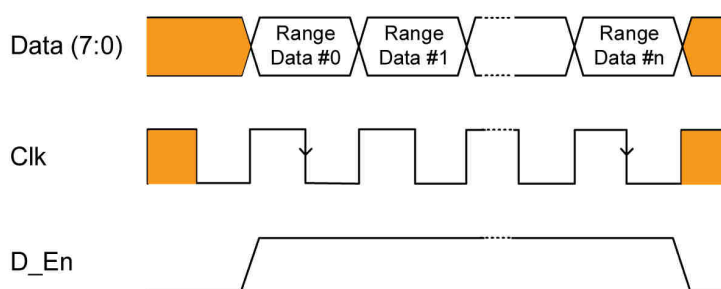

Fig. 4.35 Digital video timing

The leading edge of the D_En (data enable) is adjustable based on the T_0 trigger. The trailing edge coincides with the end of each radar sweep.

Retiming factor, status signals definition:

	Status1	Status0
Retiming factor 1	0	1
Retiming factor 2	1	0
Retiming factor 4	1	1
Retiming factor 8	0	0

4.4.10.12 X23-X24, Azimuth Output 1-2

The output follows the input of the antenna encoder corrected for installation offset and processing delay. The azimuth ACP output delivers 4096 or 8192 pulses per antenna rotation (depending on encoder type used) as well as one ARP pulse for each antenna rotation.



Description	Data or Settings
Number of outputs	2
Antenna rotation rate	As input
Pulses per revolution	4096 or 8192 ACPs and 1 ARP
Azimuth type	Antenna A, Antenna B, selectable
Pulse width, ACP and ARP	>10 μs
Format	2 x balanced lines, RS422
Connector	D-Sub 9, female

Terminal	Function	Terminal	Function
1	ACP+	6	GND
2	ACP-	7	GND
3	ARP+	8	NC
4	ARP-	9	NC
5	NC	SHELL	Shield

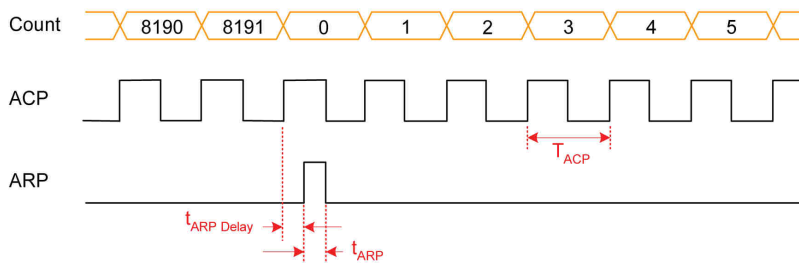

$$T_{ACP} = \frac{60}{\text{Antenna RPM} \times \text{Encoder pulses}}$$

$$t_{ARP\ Delay} = 0.25 \times T_{ACP}$$

$$t_{ARP} = 0.25 \times T_{ACP}$$

Fig. 4.36 Azimuth timing specification

4.4.10.13 X25-X28, Trigger Output 1-4

Description	Data or Settings
Number of outputs	4, each is individually programmable. The output can also be used for RF transmitting status and is programmable with pre-time of 100 μ s in steps of 1 μ s and a post-time of 100 μ s in steps of 1 μ s.
Amplitude	8 V \pm 1 V
Drive capacity	75 Ohms nominal load, max trigger duty cycle is 15%
Trigger point definition	At low-to-high transition
Rise time	< 30 ns (10-90%)
Connector	50 Ohms BNC
Cover Pulse Functionality	The output X25 can further be used as a "Cover Pulse" when configured as such by software set-up. In this case, the pulse can be programmed with a maximum blanking lead time = 1 μ s and a maximum blanking lag time = 500ns. This means the pulse is active during the complete transmit cycle of the radar with a duty cycle of up to 20% (plus lead/lag times). Otherwise, the output specification is unchanged from the above.

4.4.11 Antenna Control Unit (ACU)

The Antenna Control unit (ACU) is used for controlling antennas with a fixed turning unit. The motor controller ABB ACS-880 is intended for use with the SCANTER 5502/5602 transceiver.

The ACU housing is available with different built-in types of frequency inverter drives. The drives are specially selected to optimum performance with the different types of SCANTER antennas, with respect to available power supply and motor power needs.

The ACU can be installed on a wall, either directly or on an optional aluminium frame.

It consists of a drive, a fan, terminals to connect incoming cables (through stuffing tubes at bottom), connectors, cable glands and a safety on/off switch, and space for an optional brake kit.

For further information, including maintenance of the ACU, refer to doc. no. 978100-HT.

4.4.11.1 ACU variants

The cabinet is available with a standard ABB frequency converter and depending on power supply and motor size, four variants are available.

SCANTER antenna type	ACU supply [VAC]	Drive power [kW]	Motor power [kW]	Motor conn.	Motor current [A]	Max. current [A]
High gain	3 x 400	4.0	2.2	Y	6.0	13.6
High gain	3 x 230	4.0	2.2	D	10.4	24.8
High gain	1 x 230 / 3 x 230	7.5	2.2 / 4.0	Δ / Δ	10.4 / 15.7	30.8
High gain	3 x 400	7.5/11.0	4.0/7.5	Y/Y	9.0/15.7	23.0

4.4.11.2 ACU in installation (simplified)

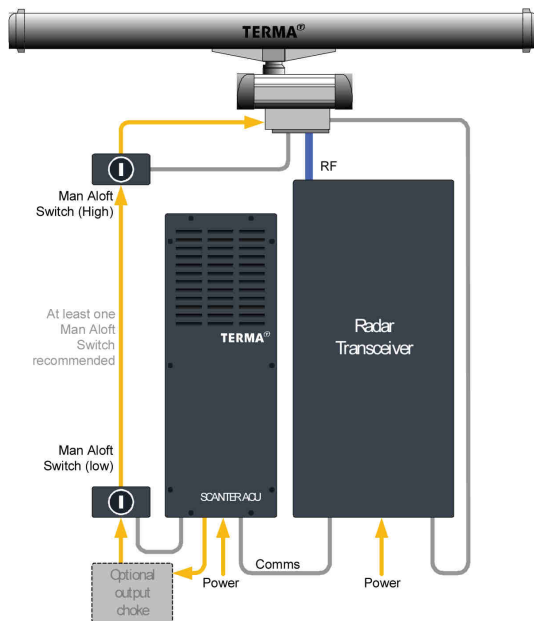

Fig. 4.37 ACU in installation

4.4.11.3 Setup of motor controller

Setup and operation of the ACS-880 motor controller is described in doc. no. 619556-MM.

4.4.11.4 Dimensions, internal wiring, etc.

For dimensions of the ACU, internal cabling, etc., refer to chapter 10 (p. 187)

5 Radar Service Tool

The Radar Service Tool (RST) is a software application used for controlling the radar system, such as parameters and BITE information, and for monitoring radar video, plots and tracks.

The RST runs on a laptop or on a PC connected to the radar LAN.

The Radar Service Tool provides the user with a consistent look and feel across the various features implemented. It supports different perspectives, where each perspective corresponds to a particular arrangement and subset of RST windows (views).

For detailed descriptions of the Radar Service Tool functions, see doc. no. 357641-HO: "SCANTER Radar Service Tool - Operator's Manual".

5.1 Installation

5.1.1 System requirements

The system requirements for the computer running the RST are found in doc. no. 357641-HI: "SCANTER Radar Service Tool".

5.1.2 Installing and starting the Radar Service Tool

Extract the zip file from the CD (357641-NF) to the computer. The startup file rst.exe is located in the directory: "357641-NF-B\rst".

Start the Radar Service Tool by double-clicking the "rst.exe" file. The user may create a shortcut to this file and place it on the desktop.

5.2 RST features

5.2.1 Authentication

The available access administration is:

- Access to the computer is protected by a normal Windows login.

5.2.2 Access levels

To operate or to change parameters in the radar it is necessary to connect to the radar using one of the three access levels available:

- Operational access level.
- Service access level.
- Debug access level.

Operational access level allows the user to change the most commonly used parameters and to operate the radar.



The service access level allows to change most of the parameters, while the debug access level is intended for technicians having intensive and detailed knowledge about the radar system.

5.2.3 User documentation

The RST “DocLib” view contains a list of documents stored on the transceiver, such as technical manuals.

5.2.4 Parameters and BITE access

Access to all necessary parameters is available through the RST.

The Radar Service Tool provides status on radar functions and performance as well as detailed status on all modules in the system. All BITE information available about the modules are shown together with any status or error message issued by the module.

5.2.5 Tools

In addition to live radar video, the RST provides the user with operator’s tools, such as A-Scope, EBL, VRM, continuous zoom, histograms, primary-, secondary- and tracks, plots, maps, etc.

These operator’s tools allow the user to perform a detailed analysis of the system performance. Display of track data is possible by clicking on the individual target, in combination with a right-click menu.

5.2.6 Situation display

The situation display presents live video, A-Scope, EBL, VRM, continuous zoom, histograms, primary-, secondary- and tracks, plots, maps, etc.

These operator tools are available to allow the user to perform more detailed analysis of the system performance. Display of track data is possible by mouse click on the individual target, in combination with a pop-up menu (right mouse click).

The situation display is one of four default perspectives, all described in the following pages.

5.3 RST screen layout

The Radar Service Tool screen layout is shown in [Fig. 5.1 \(p. 91\)](#) with definitions of the different operation areas.

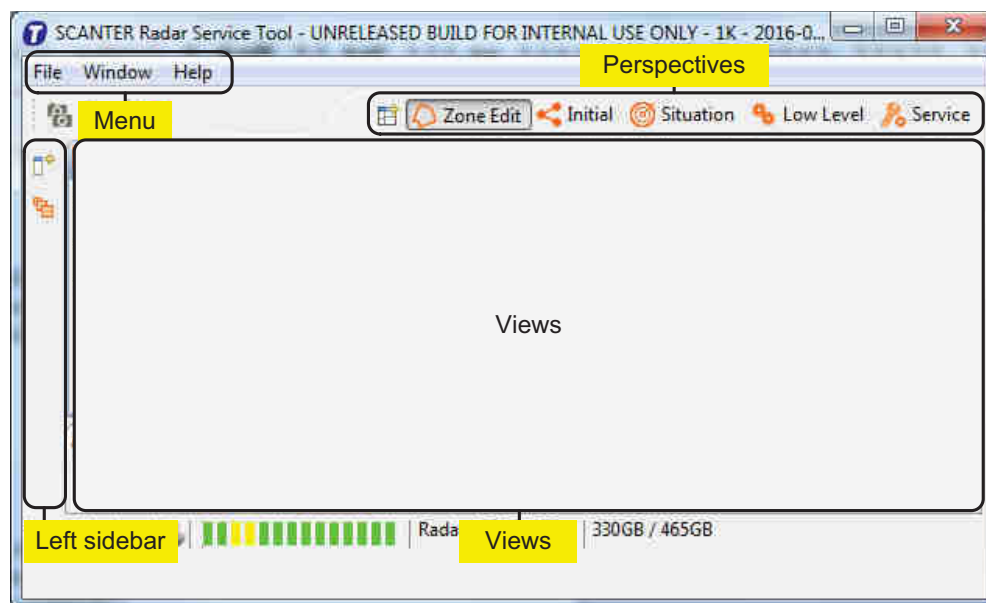

Fig. 5.1 RST - screen layout

In the “Views” area of the screen, it is possible to open interactive views for display and handling of graphical information, e.g. radar video, measurement tools, radar control, parameters, BITE information, etc.

Presentation of these views can be selected and deselected individually.

The five default perspectives are:

- Initial
- Situation
- Low Level
- Service
- Zone Edit

The “Initial” perspective is used to set up a connection to the transceiver and to backup/restore transceiver configuration data.

The “Situation” perspective contains PPI view, zoom, measurements tools, video setup and high-level radar control.

The “Low Level” perspective can be used by technicians to change parameters and to edit profiles, etc.

The “Service” perspective can be used to back up or restore transceiver data, upgrade transceiver software and to have access to documents stored in the transceiver.

The “Zone Edit” perspective contains zone views for creating and editing zones and zone parameters.

The Radar Service Tool menu bar consists of “File”, “Window” and “Help”.

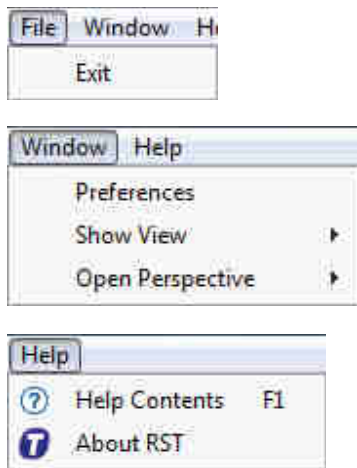

Fig. 5.2 Radar Service Tool - menus and submenus

The "File" menu is used to exit the RST, while the "Help" menu displays the RST software version and provides information on a number of topics as well as a search function. The help topics can also be displayed by pressing the F1 key anywhere in the RST user interface.

In the "Window" menu, the submenu "Preferences" is used to set default colors, units, snapshots storage directory, radar video setting such as decay, sweep, trails history, video gain, etc.

"Show View" and "Open Perspective" are used to activate a view or a perspective.

The left side bar, shown in Fig. 5.1 (p. 91), is used to open fast views. A fast view remains on the monitor as long as it is in focus. It will disappear from the monitor if the operator clicks any place outside the fast view.

5.3.1 RST keyboard and mouse actions

5.3.2 General

General	
Maximize/Restore view	Double left click on view tab
Move view to another docking	Left drag view tab

5.3.3 Adjust text size

Adjust text size	
Parameters view	Ctrl - scroll wheel
Profile Editor view	
Profile Names view	
Errors/Warnings view	
Status/Measurements view	

5.3.4 Situation perspective control

PPI view	
Re-center	Ctrl - right click
Zoom	Scroll wheel
Zoom in	Ctrl - right drag - up - right
Zoom out	Ctrl - right drag - down - left
Reset zoom and re-center to own unit position	Ctrl - right drag - up - left

Zoom view	
Define visible area in PPI view	Right drag

A-Scope view	
Zoom	Scroll wheel
Pan/Adjust VRM circle	Left drag

VRM-Scope view	
Zoom	Scroll wheel
Pan/Adjust EBL angle	Left drag

A-Scope and VRM (Tools view)	
Define EBL angle/VRM circle	Left drag
Freeze EBL/VRM	
Hide EBL/VRM	



Area Masking view	
Press buttons “Delete Mask” or “Create Mask” to start creating a polygon	
Add polygon vertices	Left click
Finish creating polygon	Right click
Delete last vertex while creating a polygon	Ctrl - left click
Abort current polygon creation	Esc

5.3.5 RST menu navigation and search

Use the four buttons at the top to the right of the view to collapse the navigation tree (All parameters) or to expand the tree. See Fig. 5.3 (p. 94). The view can be minimized into a sidebar or maximized.

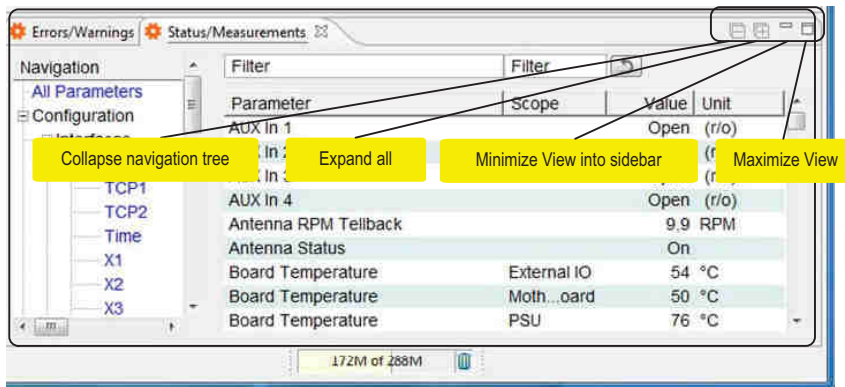

Fig. 5.3 View - control buttons

To search for a parameter, enter the parameter name in the “Parameter filter” or in the “Scope filter” field. See Fig. 5.4 (p. 94). The shown search is sector 11. To change a parameter value, simply click and enter the new value in the relevant field. The “All parameters” in the navigation tree must be selected to enable the search in the entire navigation tree.

In case a parameter cannot be found, pay attention to the log-on access level.

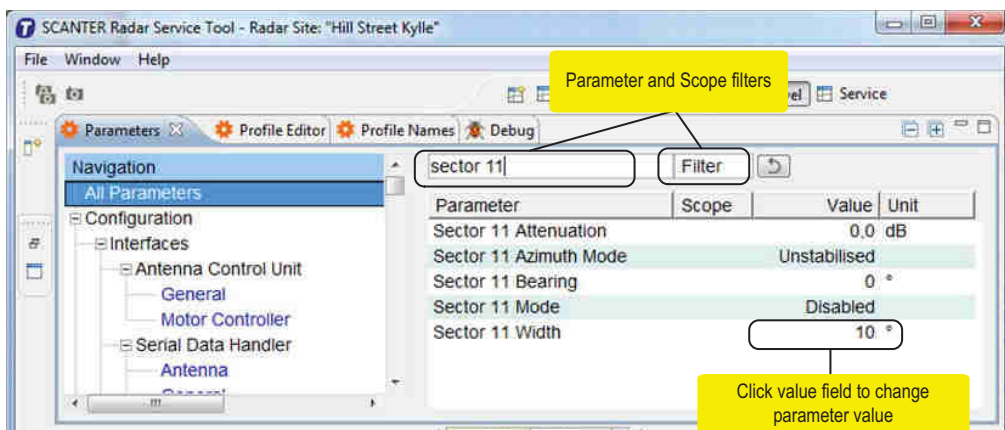

Fig. 5.4 RST - Search filters

5.4 Preferences

In the Preferences menu it is possible individually to change color and fonts. The user can select what unit format to use, specify general settings of the RST, the PPI (radar video, background, trails etc). The following sections describe the usage of the RST Preferences.

Preferences		
Color	General	Help
Perspectives	Plug-ins	RST own unit override
Unit		

Fig. 5.5 RST - Preferences

5.5 Perspectives

When launching the RST program for the first time, there are four default perspectives, each containing a certain number of views. The presentation of these views can be selected and deselected individually.

The “Initial” perspective is used when a connection to the transceiver and its services is established. See [Fig. 5.6 \(p. 95\)](#).

Initial	
Connection Manager	Connection Status

Fig. 5.6 “Initial” perspective - default

The “Situation” perspective can be used by the operator to start the transceiver and transmission, to select profile and to monitor the radar video. Measurement tools are included in this perspective. See [\(p. 95\)](#).

Situation		
PPI	Parameters	Debug
Video Setup	Area Masking	Radar Control
VRM-Scope	Histogram	A-Scope
Zones	Markers	Vectors

“Situation” perspective - default

The “Low Level” perspective provides parameter and profile views for configuring profile content and editing profile names. The Errors/Warnings and Status/Measurements views are used to monitor the health of the transceiver.

See [Fig. 5.7 \(p. 96\)](#).



Low Level		
Parameters	Profile Editor	Profile Names
Debug	Errors/Warnings	Status/Measurements
Recent Errors/Warnings		

Fig. 5.7 “Low Level” perspective - default

The “Service” perspective can be used for transceiver backup/restore and software update. Further, it provides access to the documents/user guides stored in the transceiver (DocLib) and RST log data (Console). See [Fig. 5.8 \(p. 96\)](#).

Service		
Backup/Restore	Software Update	DocLib
Console		

Fig. 5.8 “Service” perspective - default

Any default perspective can be customized by adding or removing views freely selected by the user.

Alternatively, new personal perspectives can be created, which can be stored in the perspectives area.

Views are placed inside the “Views” area, or “minimized” and placed in the sidebar areas (right and left side) of the RST window.

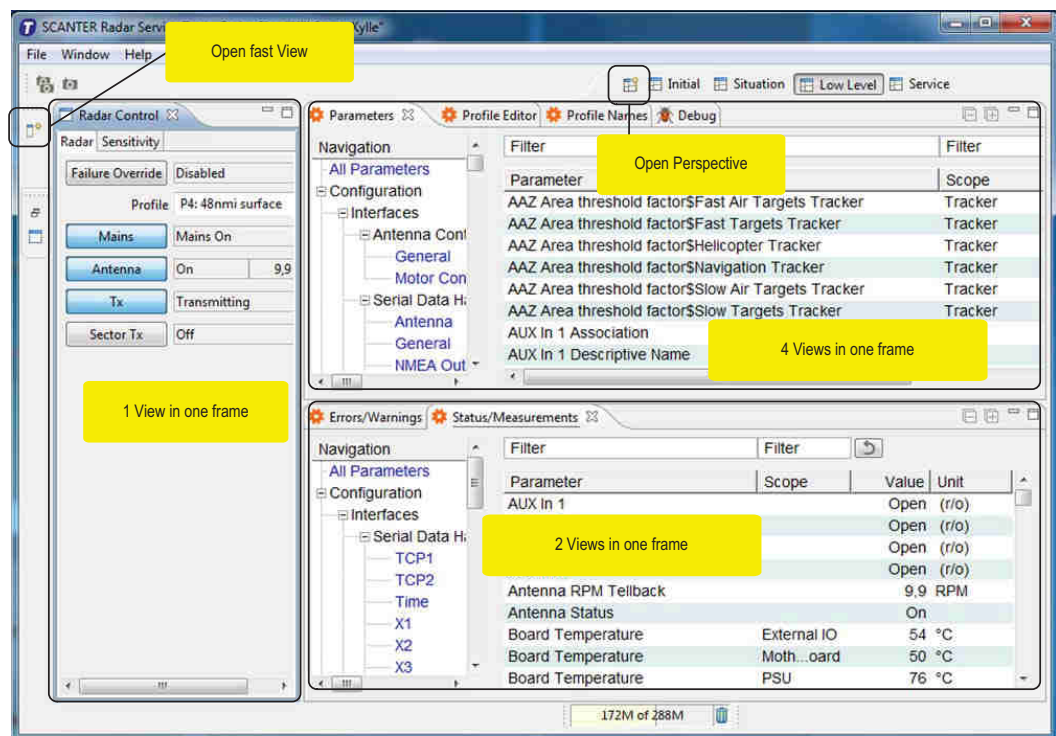

Fig. 5.9 RST - Views

A view can be placed in its own frame, or several views can be placed in the same frame/window. See Fig. 5.9 (p. 97).

To move a view within the view area, select the view tab with the left mouse button while holding down the button. Move the view to another location or inside a frame already containing one or more views.

