

**CFR 47 FCC PART 15 SUBPART C
ISED RSS-210 Issue 10**

TEST REPORT

For

WIRELESS MODULE MODEL NAME: 2.4 GHz RF Module

WIRELESS MODULE MODEL NUMBER: 1602330

REPORT NUMBER: 4791293876-1-RF-1

ISSUE DATE: July 17, 2024

FCC ID: N82-KOHLER055

IC: 4554A-KOHLER055

Prepared for

Kohler Co.

444 Highland Drive, Kohler Wisconsin, 53044 United States

Prepared by

UL Verification Services (Guangzhou) Co., Ltd, Song Shan Lake Branch

Building 10, Innovation Technology Park, No. 1, Li Bin Road, Song Shan Lake Hi-Tech Development Zone Dongguan, 523808, People's Republic of China

Tel: +86 769 22038881

Fax: +86 769 33244054

Website: www.ul.com

Revision History

Rev.	Issue Date	Revisions	Revised By
V0	July 17, 2024	Initial Issue	

Summary of Test Results			
Clause	Test Items	FCC/ISED Rules	Test Results
1	20dB Bandwidth and 99% Occupied Bandwidth	CFR 47 FCC §15.215 (c) ISED RSS-Gen Clause 6.7	Pass
2	Radiated Emission	CFR 47 FCC §15.249 (a)(d)(e) ISED RSS-210 Annex B B.10 CFR 47 FCC §15.205 and §15.209 RSS-GEN Clause 8.9 RSS-GEN Clause 8.10	Pass
3	Conducted Emission Test for AC Power Port	CFR 47 FCC §15.207 RSS-GEN Clause 8.8	Pass
4	Antenna Requirement	CFR 47 FCC §15.203 ISED RSS-Gen Clause 6.8	Pass
<p>Note 1: This test report is only published to and used by the applicant, and it is not for evidence purpose in China.</p> <p>Note 2: The measurement result for the sample received is <Pass> according to < CFR 47 FCC PART 15 SUBPART C, ISED RSS-210 ISSUE 10 > when <Accuracy Method> decision rule is applied.</p>			

CONTENTS

1. ATTESTATION OF TEST RESULTS.....	5
2. TEST METHODOLOGY.....	6
3. FACILITIES AND ACCREDITATION.....	6
4. CALIBRATION AND UNCERTAINTY	7
4.1. <i>MEASURING INSTRUMENT CALIBRATION</i>	<i>7</i>
4.2. <i>MEASUREMENT UNCERTAINTY.....</i>	<i>7</i>
5. EQUIPMENT UNDER TEST	8
5.1. <i>DESCRIPTION OF EUT</i>	<i>8</i>
5.2. <i>CHANNEL LIST</i>	<i>8</i>
5.3. <i>MAXIMUM FIELD STRENGTH</i>	<i>8</i>
5.4. <i>TEST CHANNEL CONFIGURATION.....</i>	<i>8</i>
5.5. <i>THE WORSE CASE POWER SETTING PARAMETER.....</i>	<i>9</i>
5.6. <i>DESCRIPTION OF AVAILABLE ANTENNAS</i>	<i>9</i>
5.7. <i>DESCRIPTION OF TEST SETUP.....</i>	<i>10</i>
6. MEASURING EQUIPMENT AND SOFTWARE USED.....	12
7. ANTENNA PORT TEST RESULTS	14
7.1. <i>20DB BANDWIDTH AND 99% OCCUPIED BANDWIDTH.....</i>	<i>14</i>
7.2. <i>DUTY CYCLE.....</i>	<i>18</i>
8. RADIATED TEST RESULTS.....	20
8.1. <i>RESTRICTED BANDEDGE</i>	<i>30</i>
8.2. <i>SPURIOUS EMISSIONS (1 GHZ ~ 3 GHZ)</i>	<i>33</i>
8.3. <i>SPURIOUS EMISSIONS (3 GHZ ~ 18 GHZ)</i>	<i>39</i>
8.4. <i>SPURIOUS EMISSIONS (9 KHZ ~ 30 MHZ).....</i>	<i>45</i>
8.5. <i>SPURIOUS EMISSIONS (30 MHZ ~ 1 GHZ)</i>	<i>48</i>
8.6. <i>SPURIOUS EMISSIONS (18 GHZ ~ 26 GHZ)</i>	<i>50</i>
9. AC POWER LINE CONDUCTED EMISSION	52
10. ANTENNA REQUIREMENT	55

1. ATTESTATION OF TEST RESULTS

Applicant Information

Company Name: Kohler Co.
 Address: 444 Highland Drive, Kohler Wisconsin, 53044 United States

Manufacturer Information

Company Name: Shanghai Kohler Electronics., Ltd.
 Address: No.1955, Fengxiang Road, Baoshan Area, Shanghai, 200444, PRC

EUT Information

Wireless Module Name: 2.4 GHz RF Module
 Wireless Module Model: 1602330
 Sample Received Date: June 25, 2024
 Sample ID: 7365435
 Date of Tested: June 25, 2024 to July 17, 2024

APPLICABLE STANDARDS	
STANDARD	TEST RESULTS
CFR 47 FCC PART 15 SUBPART C ISED RSS-210 Issue 10	Pass

Prepared By:

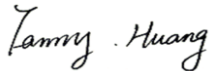

Fanny Huang
 Engineer Project Associate

Checked By:

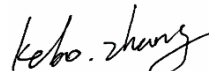

Kebo Zhang
 Senior Project Engineer

Approved By:



Stephen Guo
 Operations Manager

2. TEST METHODOLOGY

The tests documented in this report were performed in accordance with KDB 414788 D01 Radiated Test Site v01r01, FCC CFR 47 Part 2, FCC CFR 47 Part 15, ANSI C63.10-2013, ISED RSS-210 ISSUE 10 and ISED RSS-GEN Issue 5.

3. FACILITIES AND ACCREDITATION

Accreditation Certificate	<p>A2LA (Certificate No.: 4102.01) UL Verification Services (Guangzhou) Co., Ltd. Song Shan Lake Branch. has been assessed and proved to be in compliance with A2LA.</p> <p>FCC (FCC Designation No.: CN1187) UL Verification Services (Guangzhou) Co., Ltd. Song Shan Lake Branch. Has been recognized to perform compliance testing on equipment subject to the Commission's Declaration of Conformity (DoC) and Certification rules</p> <p>ISED (Company No.: 21320) UL Verification Services (Guangzhou) Co., Ltd. Song Shan Lake Branch. has been registered and fully described in a report filed with ISED. The Company Number is 21320 and the test lab Conformity Assessment Body Identifier (CABID) is CN0046.</p> <p>VCCI (Registration No.: G-20192, C-20153, T-20155 and R-20202) UL Verification Services (Guangzhou) Co., Ltd. Song Shan Lake Branch. has been assessed and proved to be in compliance with VCCI, the Membership No. is 3793. Facility Name: Chamber D, the VCCI registration No. is G-20192 and R-20202 Shielding Room B, the VCCI registration No. is C-20153 and T-20155</p>
---------------------------	---

Note 1:

All tests measurement facilities use to collect the measurement data are located at Building 10, Innovation Technology Park, No. 1, Li Bin Road, Song Shan Lake Hi-Tech Development Zone Dongguan, 523808, People's Republic of China.

Note 2:

The test anechoic chamber in UL Verification Services (Guangzhou) Co., Ltd. Song Shan Lake Branch had been calibrated and compared to the open field sites and the test anechoic chamber is shown to be equivalent to or worst case from the open field site.

Note 3:

For below 30 MHz, lab had performed measurements at test anechoic chamber and comparing to measurements obtained on an open field site. And these measurements below 30 MHz had been correlated to measurements performed on an OFS.

4. CALIBRATION AND UNCERTAINTY

4.1. MEASURING INSTRUMENT CALIBRATION

The measuring equipment utilized to perform the tests documented in this report has been calibrated in accordance with the manufacturer's recommendations and is traceable to recognized national standards.

4.2. MEASUREMENT UNCERTAINTY

Where relevant, the following measurement uncertainty levels have been estimated for tests performed on the apparatus:

Test Item	Uncertainty
Radiated Emission (Included Fundamental Emission) (9 kHz ~ 30 MHz)	2.2 dB
Radiated Emission (Included Fundamental Emission) (30 MHz ~ 1 GHz)	4.00 dB
Radiated Emission (Included Fundamental Emission) (1 GHz to 26 GHz)	5.78 dB (1 GHz ~ 18 GHz)
	5.23 dB (18 GHz ~ 26 GHz)
Duty Cycle	±0.028%
DTS and 99% Occupied Bandwidth	±0.0196%
Note: This uncertainty represents an expanded uncertainty expressed at approximately the 95% confidence level using a coverage factor of k=2.	

5. EQUIPMENT UNDER TEST

5.1. DESCRIPTION OF EUT

Wireless Module Name	2.4 GHz RF Module
Wireless Module Model	1602330

Product Description	Operation Frequency	2405 MHz ~ 2470 MHz
	Modulation Type	GFSK
Power supply for the Module	DC 5 V	
Power supply for the Host	AC 120 V, 60 Hz	

5.2. CHANNEL LIST

Channel	Frequency (MHz)	Channel	Frequency (MHz)	Channel	Frequency (MHz)	Channel	Frequency (MHz)
1	2405	2	2422	3	2450	4	2470

5.3. MAXIMUM FIELD STRENGTH

Test Mode	Frequency (MHz)	Channel Number	Maximum Peak field strength (dB μ V/m)	Maximum Average field strength (dB μ V/m)
2.4G SRD	2405 ~ 2470	1-4[4]	96.82	79.99

5.4. TEST CHANNEL CONFIGURATION

Test Mode	Test Channel	Frequency
2.4G SRD	CH 1(Low Channel), CH 3(MID Channel), CH 4(High Channel)	2405 MHz, 2450 MHz, 2470 MHz

5.5. THE WORSE CASE POWER SETTING PARAMETER

The Worse Case Power Setting Parameter under 2405 MHz ~ 2470 MHz Band				
Test Software Version		/		
Modulation Type	Transmit Antenna Number	Test Channel		
		CH 1	CH 3	CH 4
2.4G SRD	1	Default	Default	Default

5.6. DESCRIPTION OF AVAILABLE ANTENNAS

Antenna	Frequency (MHz)	Antenna Type	Maximum Antenna Gain (dBi)
1	2405-2470	Meandered printed inverted-F antenna	2

Test Mode	Transmit and Receive Mode	Description
2.4G SRD	<input checked="" type="checkbox"/> 1TX, 1RX	Antenna 1 can be used as transmitting/receiving antenna.

Note: The value of the antenna gain was declared by customer

5.7. DESCRIPTION OF TEST SETUP

SUPPORT EQUIPMENT

Item	Equipment	Brand Name	Model Name	P/N
1	PC	Lenovo	E42-80	/
2	AC Adaptor	Lenovo	ADLX65YCC3D	Input: AC 100-240V, 1.8A, 50-60Hz Output: DC 20V, 3.25A, 65.0W Max
3	UART	/	/	/

I/O CABLES

Cable No	Port	Connector Type	Cable Type	Cable Length(m)	Remarks
1	USB	/	/	/	/

ACCESSORY

Item	Equipment	Mfr/Brand	Model/Type No.	Specification	Series No.
/	/	/	/	/	/

TEST SETUP

The EUT have the engineer mode inside.

SETUP DIAGRAM FOR TEST

For AC POWER LINE CONDUCTED EMISSION

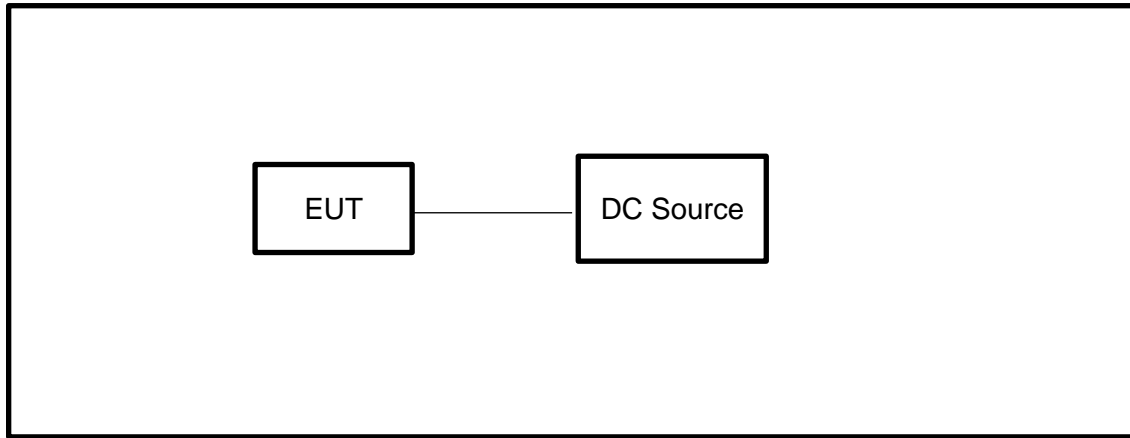

For AC POWER LINE CONDUCTED EMISSION

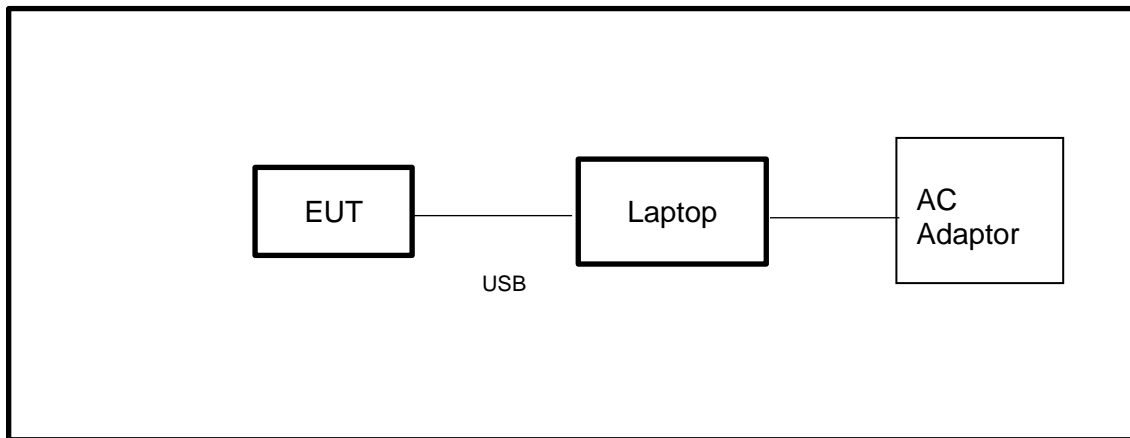

6. MEASURING EQUIPMENT AND SOFTWARE USED

Tonsend RF Test System					
Equipment	Manufacturer	Model No.	Serial No.	Last Cal.	Due. Date
PXA Signal Analyzer	Keysight	N9030A	MY55410512	Oct.12, 2023	Oct.11, 2024
EXA Signal Analyzer	Keysight	N9010B	MY57110124	May 20, 2024	May 19, 2025
Software					
Description	Manufacturer	Name		Version	
Tonsend SRD Test System	Tonsend	JS1120-3 RF Test System		2.6.77.0518	

Radiated Emissions					
Equipment	Manufacturer	Model No.	Serial No.	Last Cal.	Due Date
MXE EMI Receiver	KESIGHT	N9038A	MY56400036	Oct.12, 2023	Oct.11, 2024
Hybrid Log Periodic Antenna	TDK	HLP-3003C	130959	Aug.02, 2021	Aug.01, 2024
Preamplifier	HP	8447D	2944A09099	Oct.12, 2023	Oct.11, 2024
EMI Measurement Receiver	R&S	ESR26	101377	Oct.12, 2023	Oct.11, 2024
Horn Antenna	TDK	HRN-0118	130940	July 20, 2021	July 19, 2024
Preamplifier	TDK	PA-02-0118	TRS-305-00067	Oct.12, 2023	Oct.11, 2024
Horn Antenna	Schwarzbeck	BBHA9170	697	July 20, 2021	July 19, 2024
Preamplifier	TDK	PA-02-2	TRS-307-00003	Oct.12, 2023	Oct.11, 2024
Preamplifier	TDK	PA-02-3	TRS-308-00002	Oct.12, 2023	Oct.11, 2024
Loop antenna	Schwarzbeck	1519B	00008	Dec.14, 2021	Dec.13, 2024
Preamplifier	TDK	PA-02-001-3000	TRS-302-00050	Oct.12, 2023	Oct.11, 2024
High Pass Filter	Wi	WHKX10-2700-3000-18000-40SS	23	Oct.12, 2023	Oct.11, 2024
Band Reject Filter	Wainwright	WRCJV8-2350-2400-2483.5-2533.5-40SS	4	Oct.12, 2023	Oct.11, 2024
Software					
Description	Manufacturer	Name		Version	
Test Software for Radiated Emissions	Farad	EZ-EMC		Ver. UL-3A1	

Conducted Emissions					
Equipment	Manufacturer	Model No.	Serial No.	Last Cal.	Due Date
EMI Test Receiver	R&S	ESR3	101961	Oct.13, 2023	Oct.12, 2024
Two-Line V-Network	R&S	ENV216	101983	Oct.13, 2023	Oct.12, 2024
Artificial Mains Networks	Schwarzbeck	NSLK 8126	8126465	Oct.13, 2023	Oct.12, 2024
Software					
Description		Manufacturer	Name	Version	
Test Software for Conducted Emissions		Farad	EZ-EMC	Ver. UL-3A1	

7. ANTENNA PORT TEST RESULTS

7.1. 20DB BANDWIDTH AND 99% OCCUPIED BANDWIDTH

LIMITS

CFR 47 FCC Part15 (15.249) Subpart C RSS-Gen Issue 5			
Section	Test Item	Limit	Frequency Range (MHz)
CFR 47 FCC §15.215 (c)	20dB Bandwidth	for reporting purposes only	2400-2483.5
ISED RSS-Gen Clause 6.7 Issue 5	99% Occupied Bandwidth	For reporting purposes only.	2400-2483.5

TEST PROCEDURE

Connect the UUT to the spectrum analyzer and use the following settings:

Center Frequency	The center frequency of the channel under test
Detector	Peak
RBW	1% to 5% of the occupied bandwidth
VBW	approximately 3×RBW
Trace	Max hold
Sweep	Auto couple

Allow the trace to stabilize and measure the maximum width of the emission that is constrained by the frequencies associated with the two outermost amplitude points (upper and lower frequencies) that are attenuated by 20 dB/99% relative to the maximum level measured in the fundamental emission.

TEST SETUP

Above 1 GHz

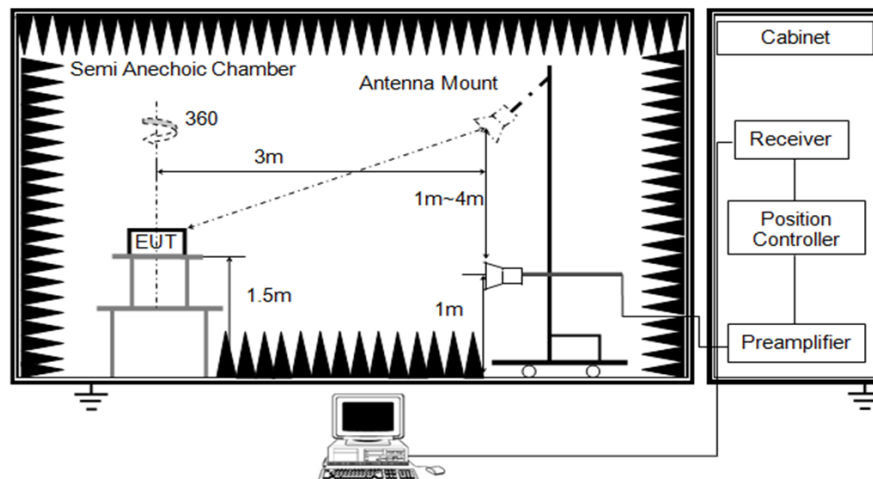

TEST ENVIRONMENT

Temperature	23.8°C	Relative Humidity	55%
Atmosphere Pressure	101kPa	Test Voltage	DC 5 V

TEST RESULTS

Frequency (MHz)	99% Bandwidth (MHz)	20dB Bandwidth (MHz)	Result
2405	2.0485	2.093	PASS

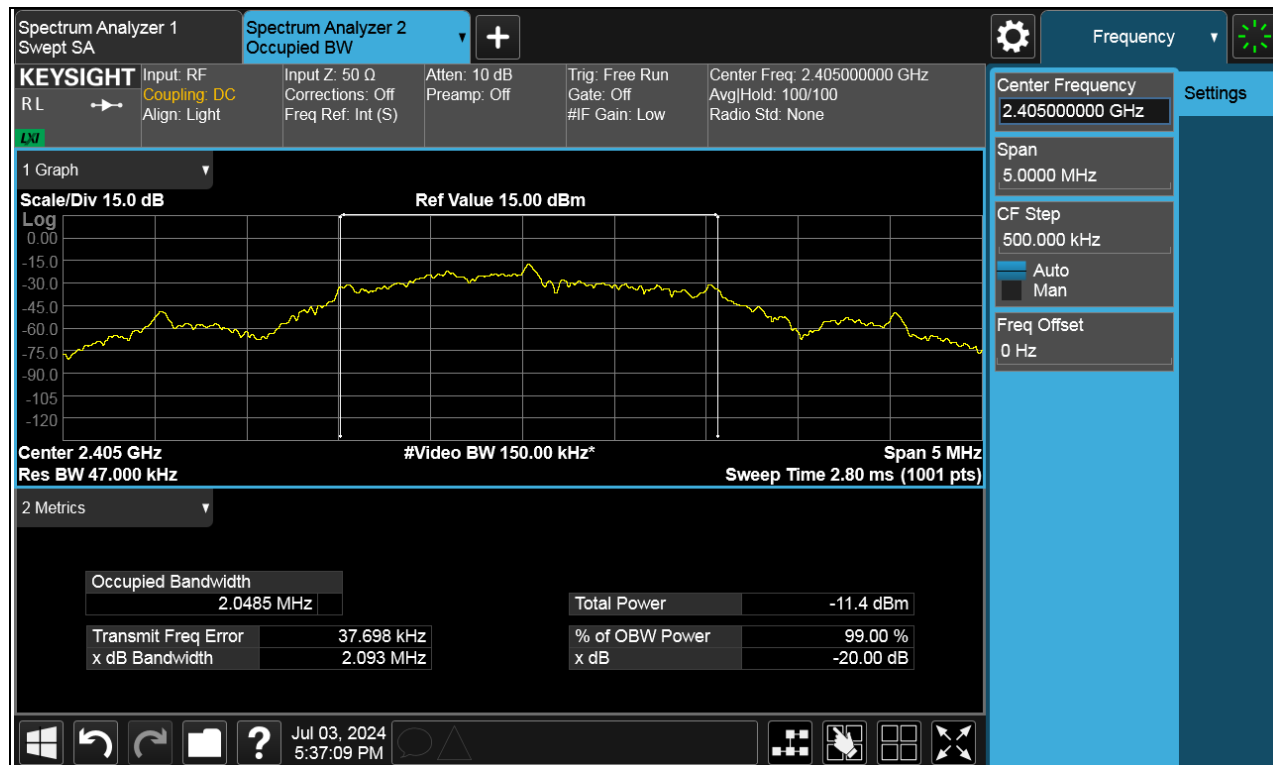

Frequency (MHz)	99% Bandwidth (MHz)	20dB Bandwidth (MHz)	Result
2450	2.0384	2.090	PASS

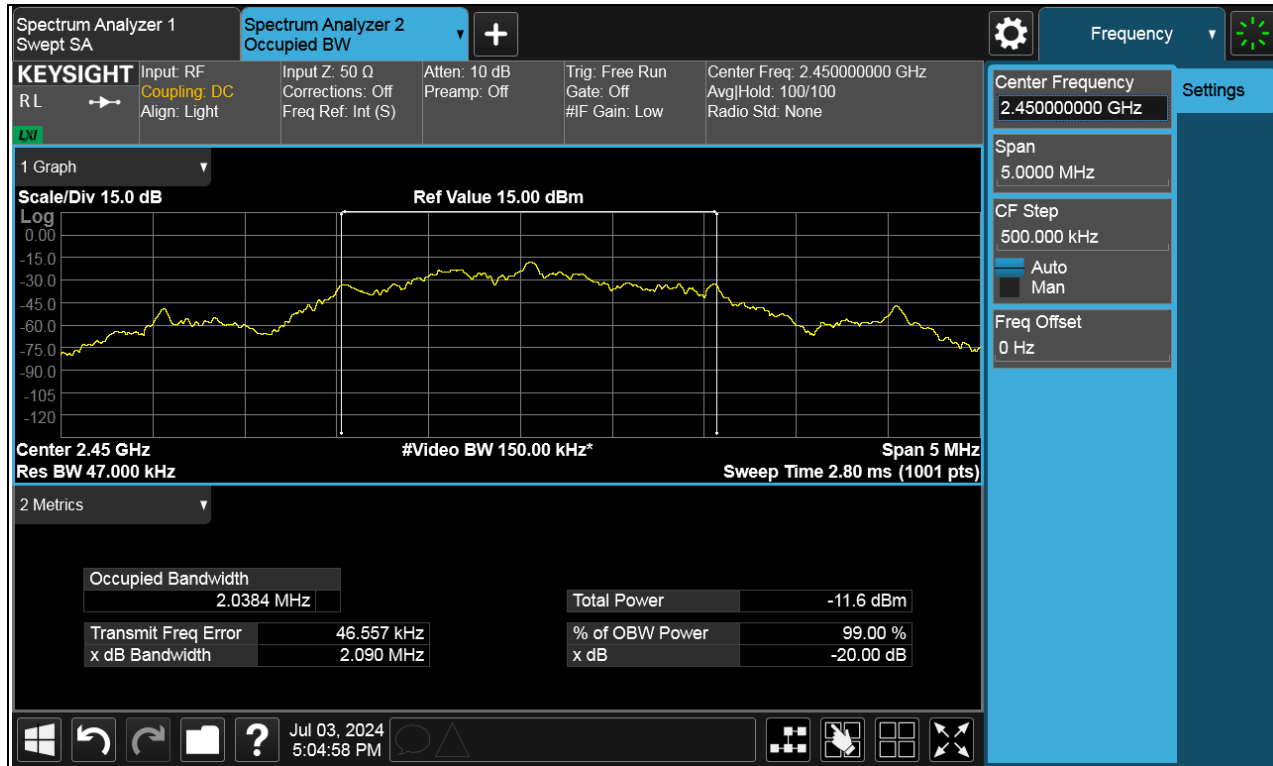

Frequency (MHz)	99% Bandwidth (MHz)	20dB Bandwidth (MHz)	Result
2470	2.0268	2.067	PASS

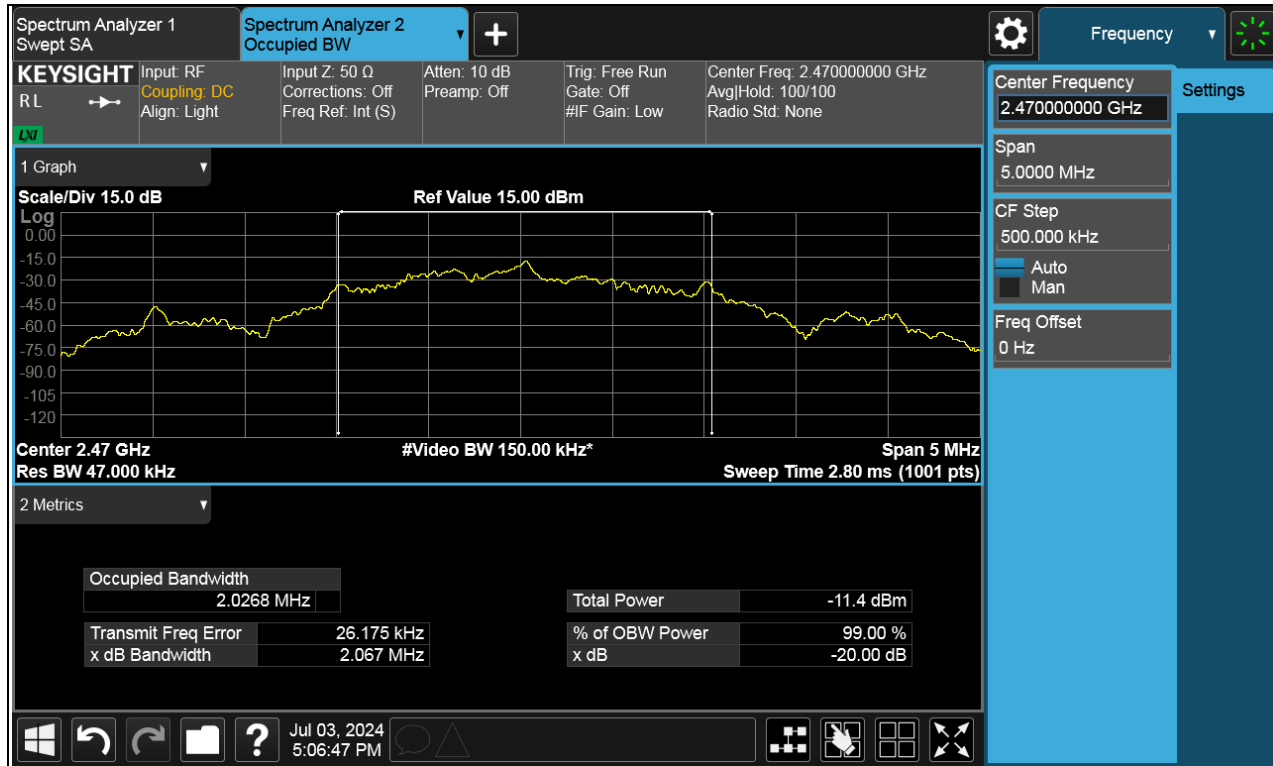

7.2. DUTY CYCLE

LIMITS

None; for reporting purposes only.

TEST PROCEDURE

Refer to ANSI C63.10-2013 clause 11.6 Zero – Span Spectrum Analyzer method.

TEST SETUP

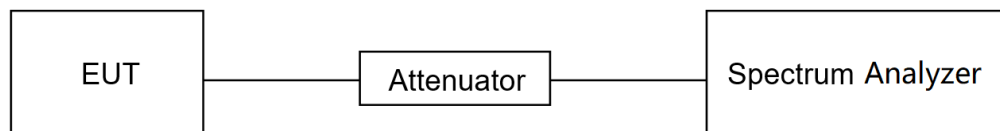

TEST ENVIRONMENT

Temperature	23.8°C	Relative Humidity	55%
Atmosphere Pressure	101kPa	Test Voltage	DC 5 V

TEST RESULTS

Mode	On Time (msec)	Period (msec)	Duty Cycle x (Linear)	Duty Cycle (%)	Duty Cycle Correction Factor (db)
2.4G SRD	0.1469	1.020	0.1440	14.40	-16.83

Note: Duty Cycle Correction Factor=20log(x).
Where: x is Duty Cycle

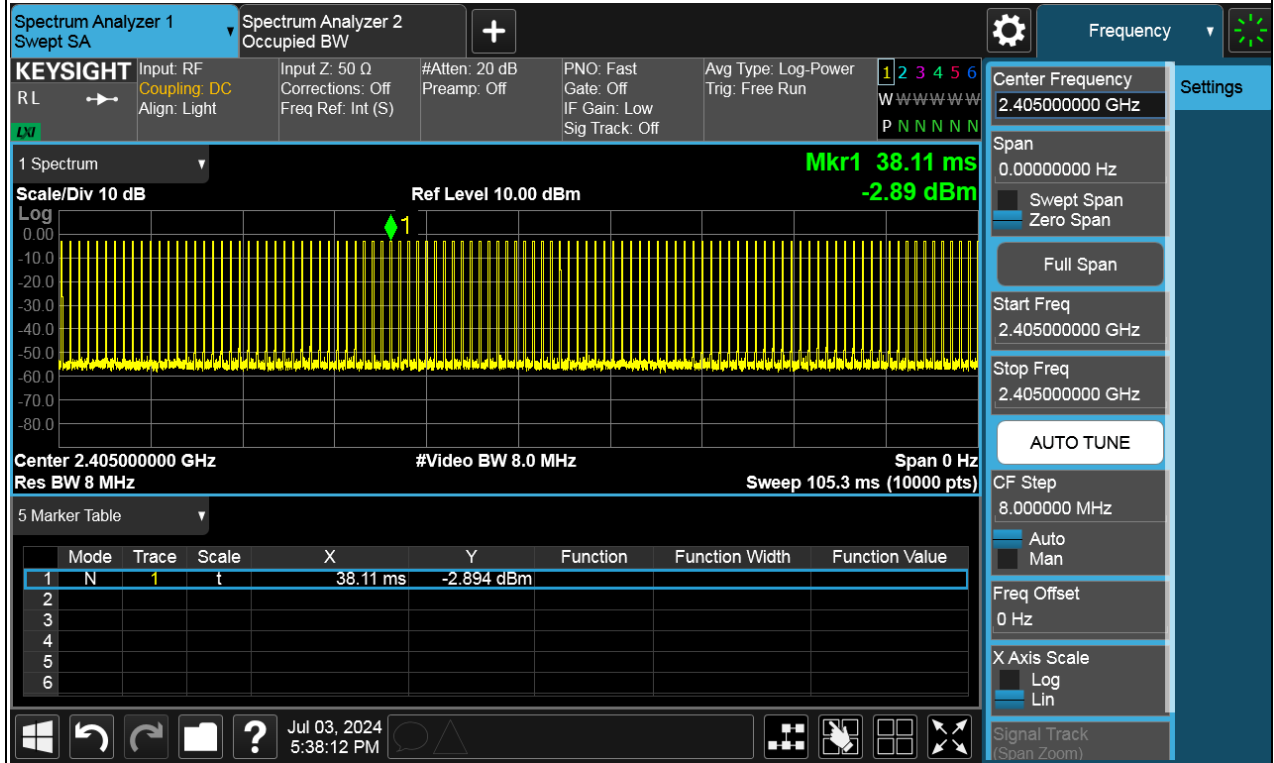
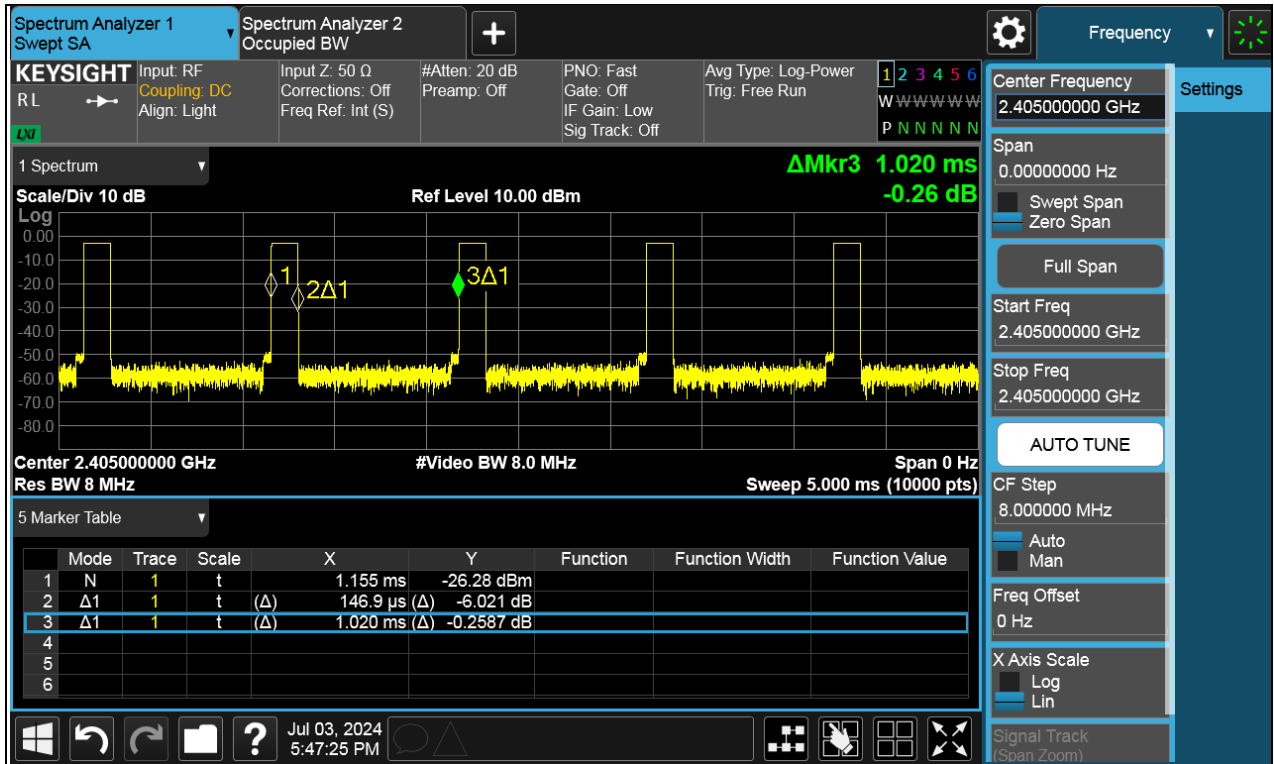

8. RADIATED TEST RESULTS

LIMITS

Please refer to CFR 47 FCC §15.205 and §15.209.

Please refer to ISED RSS-GEN Clause 8.9 and Clause 8.10.

Radiation Disturbance Test Limit for FCC (Class B) (9 kHz ~ 1 GHz)

FCC field strength of emissions from intentional radiators operated within these frequency bands			
Frequency (MHz)	Field strength of Fundamental	Field strength of Harmonics	Distance (m)
902 - 928	50 mV/m (94 dBuV/m)	500 uV/m (54 dBuV/m)	3
2400 – 2483.5	50 mV/m (94 dBuV/m)	500 uV/m (54 dBuV/m)	3
5725 – 5875	50 mV/m (94 dBuV/m)	500 uV/m (54 dBuV/m)	3

The field strength of fundamental and harmonic emissions measured at 3 m shall not exceed the limits in table B2 for ISED.

Table B2 — Field strength limits at various frequencies		
Frequency bands (MHz)	Field strength (mV/m)	
	Fundamental emissions	Harmonic emissions
902-928	50	0.5
2400-2483.5	50	0.5
5725-5875	50	0.5
24000-24250	250	2.5

Emissions radiated outside of the specified frequency bands above 30 MHz			
Frequency Range (MHz)	Field Strength Limit (uV/m) at 3 m	Field Strength Limit (dBuV/m) at 3 m	
		Quasi-Peak	
30 - 88	100	40	
88 - 216	150	43.5	
216 - 960	200	46	
Above 960	500	54	
Above 1000	500	Peak	Average
		74	54

FCC Emissions radiated outside of the specified frequency bands below 30 MHz		
Frequency (MHz)	Field strength (microvolts/meter)	Measurement distance (meters)
0.009-0.490	2400/F(kHz)	300
0.490-1.705	24000/F(kHz)	30
1.705-30.0	30	30

ISED General field strength limits at frequencies below 30 MHz

Table 6 – General field strength limits at frequencies below 30 MHz		
Frequency	Magnetic field strength (H-Field) (µA/m)	Measurement distance (m)
9 - 490 kHz ^{Note 1}	6.37/F (F in kHz)	300
490 - 1705 kHz	63.7/F (F in kHz)	30
1.705 - 30 MHz	0.08	30

Note 1: The emission limits for the ranges 9-90 kHz and 110-490 kHz are based on measurements employing a linear average detector.

ISED Restricted bands please refer to ISED RSS-GEN Clause 8.10

Table 7 – Restricted frequency bands ^{Note 1}		
MHz	MHz	GHz
0.090 - 0.110	149.9 - 150.05	9.0 - 9.2
0.495 - 0.505	158.52475 - 158.52525	9.3 - 9.5
2.1735 - 2.1905	158.7 - 158.9	10.6 - 12.7
3.020 - 3.028	162.0125 - 167.17	13.25 - 13.4
4.125 - 4.128	167.72 - 173.2	14.47 - 14.5
4.17725 - 4.17775	240 - 285	15.35 - 16.2
4.20725 - 4.20775	322 - 335.4	17.7 - 21.4
5.877 - 5.883	399.9 - 410	22.01 - 23.12
6.215 - 6.218	608 - 614	23.6 - 24.0
6.26775 - 6.26825	980 - 1427	31.2 - 31.8
6.31175 - 6.31225	1435 - 1828.5	36.43 - 38.5
8.291 - 8.294	1645.5 - 1646.5	Above 38.0
8.362 - 8.366	1860 - 1710	
8.37625 - 8.38675	1718.8 - 1722.2	
8.41425 - 8.41475	2200 - 2300	
12.29 - 12.293	2310 - 2390	
12.51975 - 12.52025	2483.5 - 2500	
12.57675 - 12.57725	2855 - 2900	
13.36 - 13.41	3280 - 3287	
16.42 - 16.423	3332 - 3339	
16.69475 - 16.69525	3345.8 - 3358	
16.80425 - 16.80475	3500 - 4400	
25.5 - 25.67	4500 - 5150	
37.5 - 38.25	5350 - 5480	
73 - 74.6	7250 - 7750	
74.8 - 75.2	8025 - 8500	
108 - 138		

Note 1: Certain frequency bands listed in table 7 and in bands above 38.6 GHz are designated for licence-exempt applications. These frequency bands and the requirements that apply to related devices are set out in the 200 and 300 series of RSSs.

FCC Restricted bands of operation refer to FCC §15.205 (a):

MHz	MHz	MHz	GHz
0.090-0.110	16.42-16.423	399.9-410	4.5-5.15
¹ 0.495-0.505	16.69475-16.69525	608-614	5.35-5.46
2.1735-2.1905	16.80425-16.80475	960-1240	7.25-7.75
4.125-4.128	25.5-25.67	1300-1427	8.025-8.5
4.17725-4.17775	37.5-38.25	1435-1626.5	9.0-9.2
4.20725-4.20775	73-74.6	1645.5-1646.5	9.3-9.5
6.215-6.218	74.8-75.2	1660-1710	10.6-12.7
6.26775-6.26825	108-121.94	1718.8-1722.2	13.25-13.4
6.31175-6.31225	123-138	2200-2300	14.47-14.5
8.291-8.294	149.9-150.05	2310-2390	15.35-16.2
8.362-8.366	156.52475-156.52525	2483.5-2500	17.7-21.4
8.37625-8.38675	156.7-156.9	2690-2900	22.01-23.12
8.41425-8.41475	162.0125-167.17	3260-3267	23.6-24.0
12.29-12.293	167.72-173.2	3332-3339	31.2-31.8
12.51975-12.52025	240-285	3345.8-3358	36.43-36.5
12.57675-12.57725	322-335.4	3600-4400	(²)
13.36-13.41			

Note: ¹Until February 1, 1999, this restricted band shall be 0.490-0.510 MHz.

²Above 38.6c

TEST PROCEDURE

Below 30 MHz

The setting of the spectrum analyzer

RBW	200 Hz (From 9 kHz to 0.15 MHz)/ 9 kHz (From 0.15 MHz to 30 MHz)
VBW	200 Hz (From 9 kHz to 0.15 MHz)/ 9 kHz (From 0.15 MHz to 30 MHz)
Sweep	Auto

1. The testing follows the guidelines in ANSI C63.10-2013 clause 6.4.
2. The EUT was arranged to its worst case and then turntable (from 0 degree to 360 degrees) to find the maximum reading. A pre-amp and a high pass filter are used for the test in order to get better signal level. Both Horizontal, Face-on and Face-off polarizations of the antenna are set to make the measurement.
3. The EUT was placed on a turntable with 80 cm above ground.
4. The EUT was set 3 meters from the interference receiving antenna, which was mounted on the top of a 1 m height antenna tower.
5. The radiated emission limits are based on measurements employing a CISPR quasi-peak detector except for the frequency bands 9-90 kHz, 110-490 kHz and above 1000 MHz Radiated emission limits in these three bands are based on measurements employing an average detector.
6. For measurement below 1 GHz, the initial step in collecting conducted emission data is a spectrum analyzer peak detector mode pre-scanning the measurement frequency range. Significant peaks are then marked and then Quasi Peak and average detector mode re-measured. If the emission level of the EUT measured by the peak detector is 3 dB lower than the applicable limit, the peak emission level will be reported. Otherwise, the emission measurement will be repeated using the quasi-peak and average detector and reported.
7. Although these tests were performed other than open field site, adequate comparison measurements were confirmed against 30m open field site. Therefore sufficient tests were made to demonstrate that the alternative site produces results that correlate with the ones of tests made in an open field site based on KDB 414788.
8. The limits in CFR 47, Part 15, Subpart C, paragraph 15.209 (a), are identical to those in RSS-GEN Section 8.9, Table 6, since the measurements are performed in terms of magnetic field strength and converted to electric field strength levels (as reported in the table) using the free space impedance of 377Ω . For example, the measurement frequency X kHz resulted in a level of Y dBuV/m, which is equivalent to $Y-51.5 = Z$ dBuA/m, which has the same margin, W dB, to the corresponding RSS-GEN Table 6 limit as it has to be 15.209(a) limit.

Below 1 GHz and above 30 MHz

The setting of the spectrum analyzer

RBW	120 kHz
VBW	300 kHz
Sweep	Auto
Detector	Peak/QP
Trace	Max hold

1. The testing follows the guidelines in ANSI C63.10-2013 clause 6.5.
2. The EUT was arranged to its worst case and then tune the antenna tower (from 1 m to 4 m) and turntable (from 0 degree to 360 degrees) to find the maximum reading. A pre-amp and a high pass filter are used for the test in order to get better signal level. Both horizontal and vertical polarizations of the antenna are set to make the measurement.
3. The EUT was placed on a turntable with 80 cm above ground.
4. The EUT was set 3 meters from the interference receiving antenna, which was mounted on the top of a variable height antenna tower.
5. For measurement below 1 GHz, the initial step in collecting conducted emission data is a spectrum analyzer peak detector mode pre-scanning the measurement frequency range. Significant peaks are then marked and then Quasi Peak detector mode re-measured. If the emission level of the EUT measured by the peak detector is 3 dB lower than the applicable limit, the peak emission level will be reported. Otherwise, the emission measurement will be repeated using the quasi-peak detector and reported.

Above 1 GHz

The setting of the spectrum analyzer

RBW	1 MHz
VBW	3 MHz
Sweep	Auto
Detector	Peak
Trace	Max hold

1. The testing follows the guidelines in ANSI C63.10-2013 clause 6.6.
2. The EUT was arranged to its worst case and then tune the antenna tower (from 1 m to 4 m) and turntable (from 0 degree to 360 degrees) to find the maximum reading. A pre-amp and a high pass filter are used for the test in order to get better signal level. Both horizontal and vertical polarizations of the antenna are set to make the measurement.
3. The EUT was placed on a turntable with 1.5 m above ground.
4. The EUT was set 3 meters from the interference receiving antenna, which was mounted on the top of a variable height antenna tower.
5. For measurement above 1 GHz, the emission measurement will be measured by the peak detector. This peak level, once corrected, must comply with the limit specified in Section 15.209.
6. For measurements above 1 GHz the resolution bandwidth is set to 1 MHz, then the video bandwidth is set to 3 MHz for peak measurements. $AVG\ Result = Peak\ Result + Duty\ Cycle\ Correction\ Factor$. For the + Duty Cycle Correction Factor please refer to clause 7.2. ON TIME AND DUTY CYCLE.

X axis, Y axis, Z axis positions:

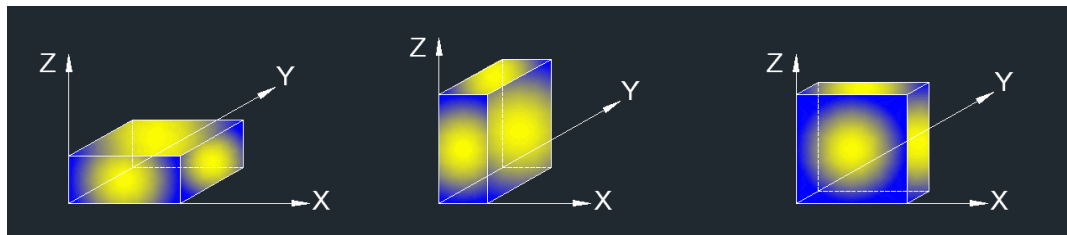

Note: For all radiated test, EUT in each of three orthogonal axis emissions had been tested, but only the worst case (X axis) data recorded in the report.

For Restricted Bandedge and field strength of intentional emission:

Note:

1. Measurement = Reading Level + Correct Factor.
2. If the peak values are less than the average limit of 54 dBuV/m, the average result is deemed to comply with average limit.
3. Peak: Peak detector.
4. AVG Result=Peak Result + Duty Cycle Correction Factor.
5. For the transmitting duration, please refer to clause 7.2.
6. Only the worst data was recorded, if it complies with the limit, the other emissions deemed to comply with the limit.
7. Both horizontal and vertical have been tested, only the worst data was recorded in the report.
8. All modes, channels and antennas have been tested, only the worst data was recorded in the report.

For Radiate Spurious emission (9 kHz ~ 30 MHz):

Note:

1. Measurement = Reading Level + Correct Factor.
2. If the peak values are less than the QP limit, the QP result is deemed to comply with QP limit.
3. All 3 polarizations (Horizontal, Face-on and Face-off) of the loop antenna had been tested, but only the worst data recorded in the report.
4. All modes, channels and antennas have been tested, only the worst data was recorded in the report.

For Radiate Spurious Emission (30 MHz ~ 1 GHz):

Note:

1. Result Level = Read Level + Correct Factor.
2. If the peak values are less than the QP limit, the QP result is deemed to comply with QP limit.
3. All modes, channels and antennas have been tested, only the worst data was recorded in the report.

For Radiate Spurious Emission (1 GHz ~ 3 GHz):

1. Measurement = Reading Level + Correct Factor.
2. If the peak values are less than the average limit of 54 dBuV/m, the average result is deemed to comply with average limit.
3. Peak: Peak detector.
4. AVG Result=Peak Result + Duty Cycle Correction Factor.
5. For the transmitting duration, please refer to clause 7.2.
6. Filter losses were only considered in the spurious frequency bands and the authorized band was not corrected for Band reject filter losses.
7. Proper operation of the transmitter prior to adding the filter to the measurement chain.
8. All modes, channels and antennas have been tested, only the worst data was recorded in the report.

For Radiate Spurious Emission (3 GHz ~ 18 GHz):

Note:

1. Peak Result = Reading Level + Correct Factor.
2. If the peak values are less than the average limit of 54 dBuV/m, the average result is deemed to comply with average limit.
3. Peak: Peak detector.
4. AVG Result=Peak Result + Duty Cycle Correction Factor.
5. For the transmitting duration, please refer to clause 7.2.
6. Filter losses were only considered in the spurious frequency bands and the authorized band was not corrected for High Pass Filter losses.
7. Proper operation of the transmitter prior to adding the filter to the measurement chain.
8. All modes, channels and antennas have been tested, only the worst data was recorded in the report.

For Radiate Spurious emission (18 GHz ~ 26 GHz):

Note:

1. Measurement = Reading Level + Correct Factor.
2. If the peak values are less than the average limit of 54 dBuV/m, the average result is deemed to comply with average limit.
3. Peak: Peak detector.
4. All modes, channels and antennas have been tested, only the worst data was recorded in the report.

TEST SETUP

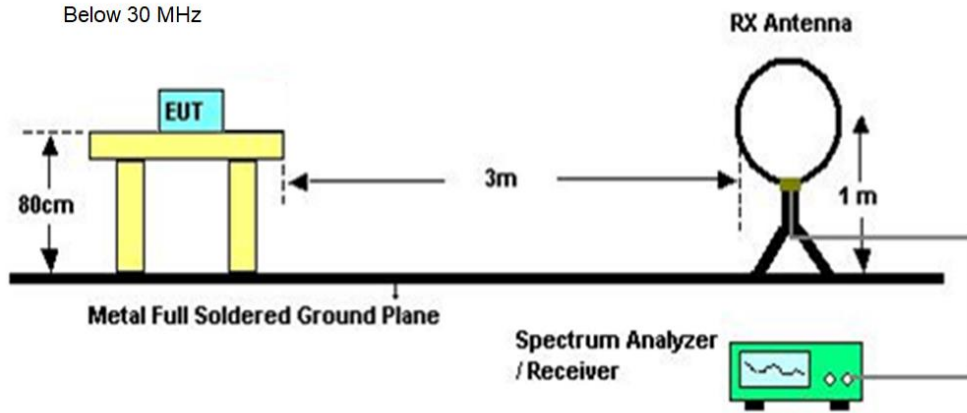

Below 1 GHz and above 30 MHz

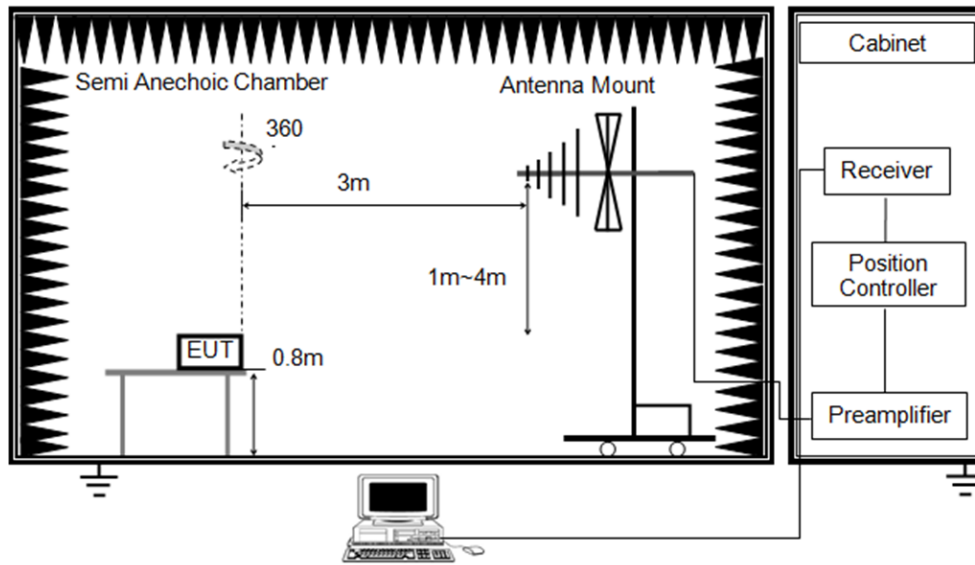

Above 1 GHz

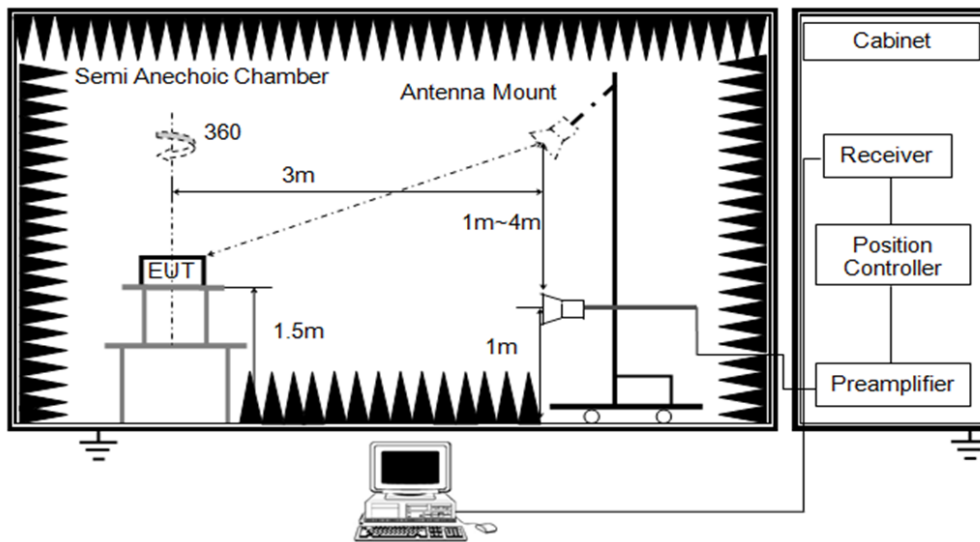

TEST ENVIRONMENT

Temperature	24.5°C	Relative Humidity	56%
Atmosphere Pressure	101kPa	Test Voltage	DC 5 V

TEST RESULTS

8.1. RESTRICTED BANDEGE

Test Mode:	SRD 2.4GHz PK	Frequency(MHz):	2405
Polarity:	Horizontal	Test Voltage:	DC 5 V

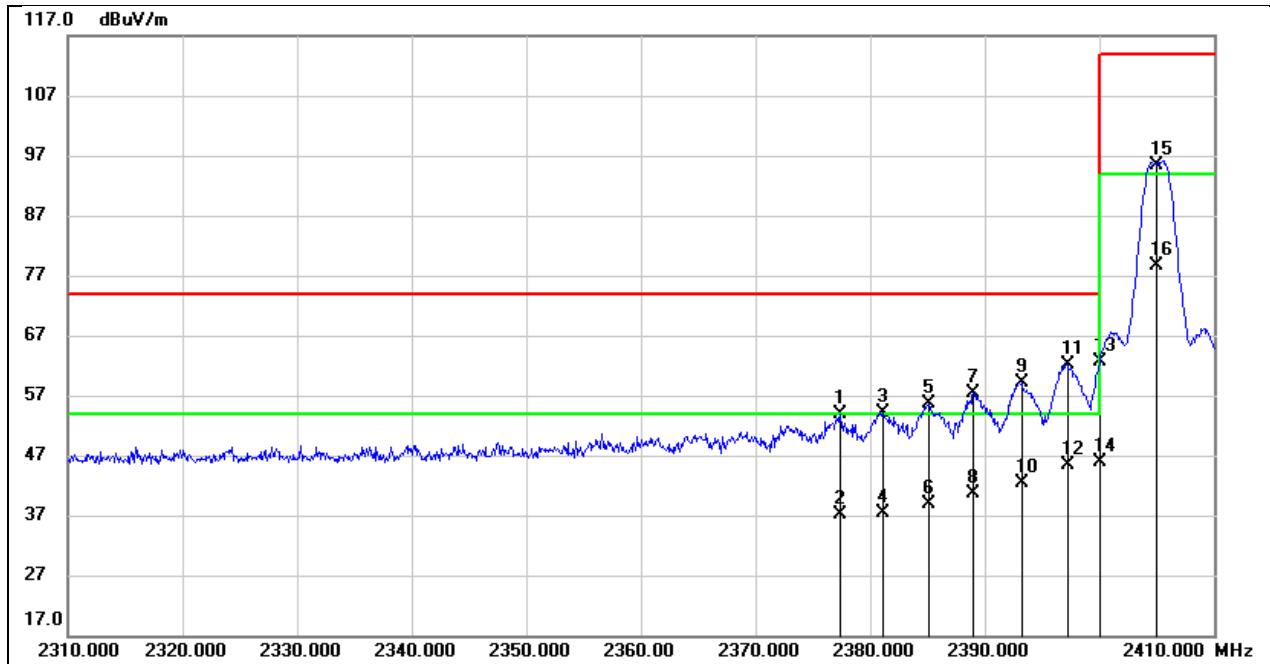

No.	Frequency (MHz)	Reading (dBuV)	Correct (dB/m)	Result (dBuV/m)	Limit (dBuV/m)	Margin (dB)	Remark
1	2377.400	21.11	32.85	53.96	74.00	-20.04	peak
2	2377.400	/	/	37.13	54.00	-16.87	AVG
3	2381.100	21.26	32.88	54.14	74.00	-19.86	peak
4	2381.100	/	/	37.31	54.00	-16.69	AVG
5	2385.100	22.70	32.90	55.60	74.00	-18.40	peak
6	2385.100	/	/	38.77	54.00	-15.23	AVG
7	2389.000	24.56	32.92	57.48	74.00	-16.52	peak
8	2389.000	/	/	40.65	54.00	-13.35	AVG
9	2393.200	26.27	32.94	59.21	74.00	-14.79	peak
10	2393.200	/	/	42.38	54.00	-11.62	AVG
11	2397.200	29.15	32.96	62.11	74.00	-11.89	peak
12	2397.200	/	/	45.28	54.00	-8.72	AVG
13	2400.000	29.75	32.98	62.73	74.00	-11.27	peak
14	2400.000	/	/	45.90	54.00	-8.10	AVG
15	2405.000	62.50	32.97	95.47	114.00	-18.53	peak
16	2405.000	/	/	78.64	94.00	-15.36	AVG

Test Mode:	SRD 2.4GHz PK	Frequency(MHz):	2450
Polarity:	Horizontal	Test Voltage:	DC 5 V

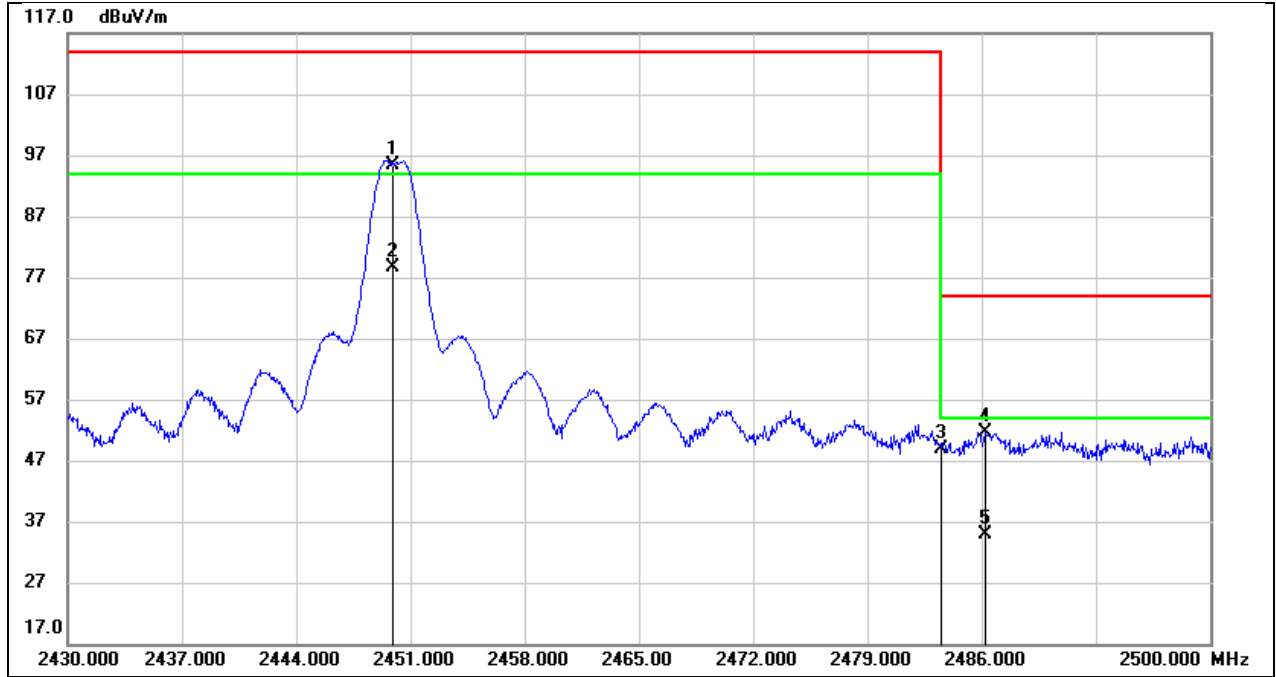

No.	Frequency (MHz)	Reading (dBuV)	Correct (dB/m)	Result (dBuV/m)	Limit (dBuV/m)	Margin (dB)	Remark
1	2450	62.5	32.96	95.46	114	-18.54	peak
2	2450	/	/	78.63	94	-15.37	AVG
3	2483.5	15.93	32.94	48.87	74	-25.13	peak
4	2486.21	18.81	32.93	51.74	74	-22.26	peak
5	2486.21	/	/	34.91	54	-19.09	AVG

Test Mode:	SRD 2.4GHz PK	Frequency(MHz):	2470
Polarity:	Horizontal	Test Voltage:	DC 5 V

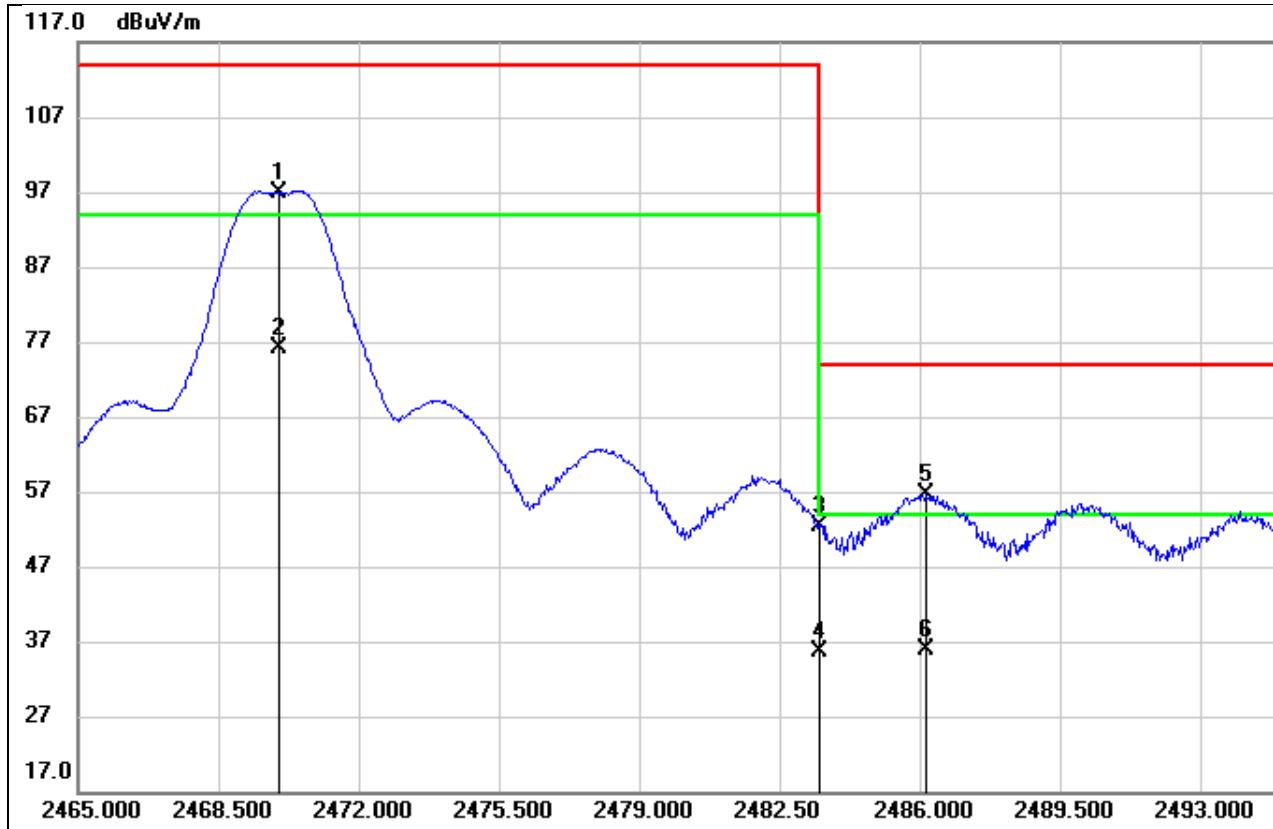

No.	Frequency (MHz)	Reading (dBuV)	Correct (dB/m)	Result (dBuV/m)	Limit (dBuV/m)	Margin (dB)	Remark
1	2470	63.88	32.94	96.82	114	-17.18	peak
2	2470	/	/	79.99	94	-14.01	AVG
3	2483.5	19.53	32.94	52.47	74	-21.53	peak
4	2483.5	/	/	35.64	54	-18.36	AVG
5	2486.14	23.69	32.93	56.62	74	-17.38	peak
6	2486.14	/	/	39.79	54	-14.21	AVG

8.2. SPURIOUS EMISSIONS (1 GHZ ~ 3 GHZ)

Test Mode:	SRD 2.4GHz	Frequency(MHz):	2405
Polarity:	Horizontal	Test Voltage:	DC 5 V

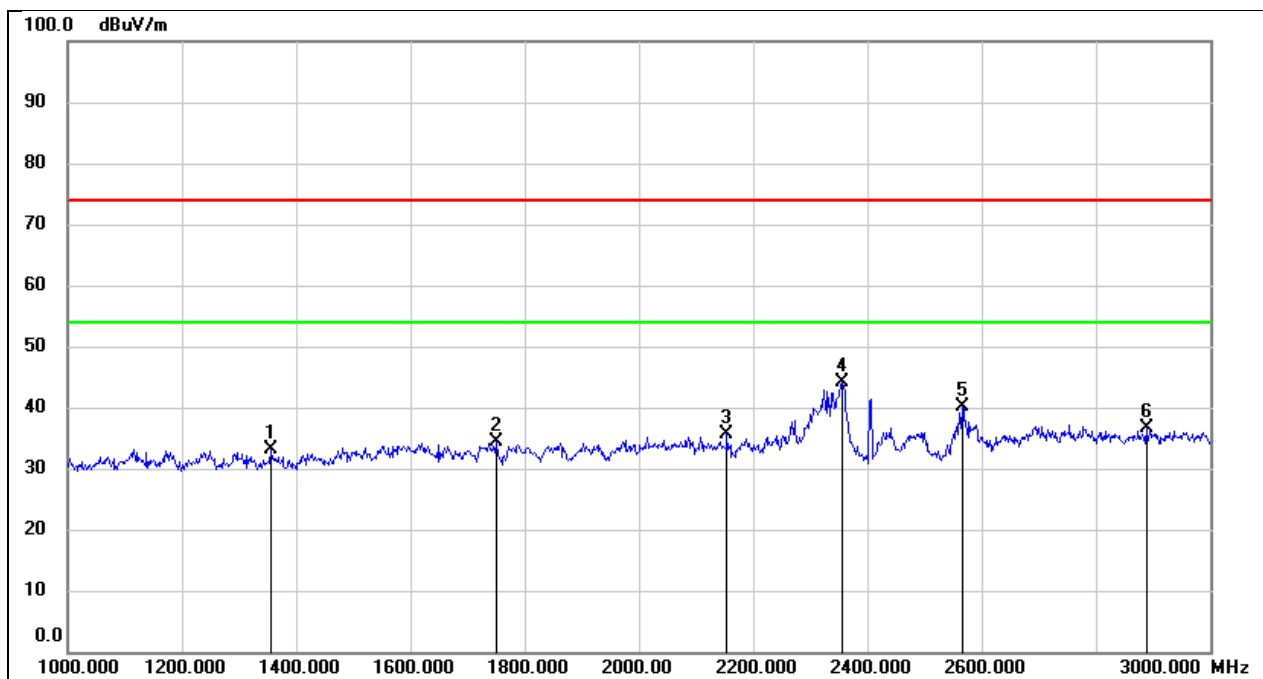

No.	Frequency (MHz)	Reading (dBuV)	Correct (dB/m)	Result (dBuV/m)	Limit (dBuV/m)	Margin (dB)	Remark
1	1356.000	45.55	-12.46	33.09	74.00	-40.91	peak
2	1750.000	44.97	-10.47	34.50	74.00	-39.50	peak
3	2154.000	44.72	-9.16	35.56	74.00	-38.44	peak
4	2356.000	51.79	-7.72	44.07	74.00	-29.93	peak
5	2566.000	47.75	-7.61	40.14	74.00	-33.86	peak
6	2888.000	43.12	-6.40	36.72	74.00	-37.28	peak

Test Mode:	SRD 2.4GHz	Frequency(MHz):	2405
Polarity:	Vertical	Test Voltage:	DC 5 V

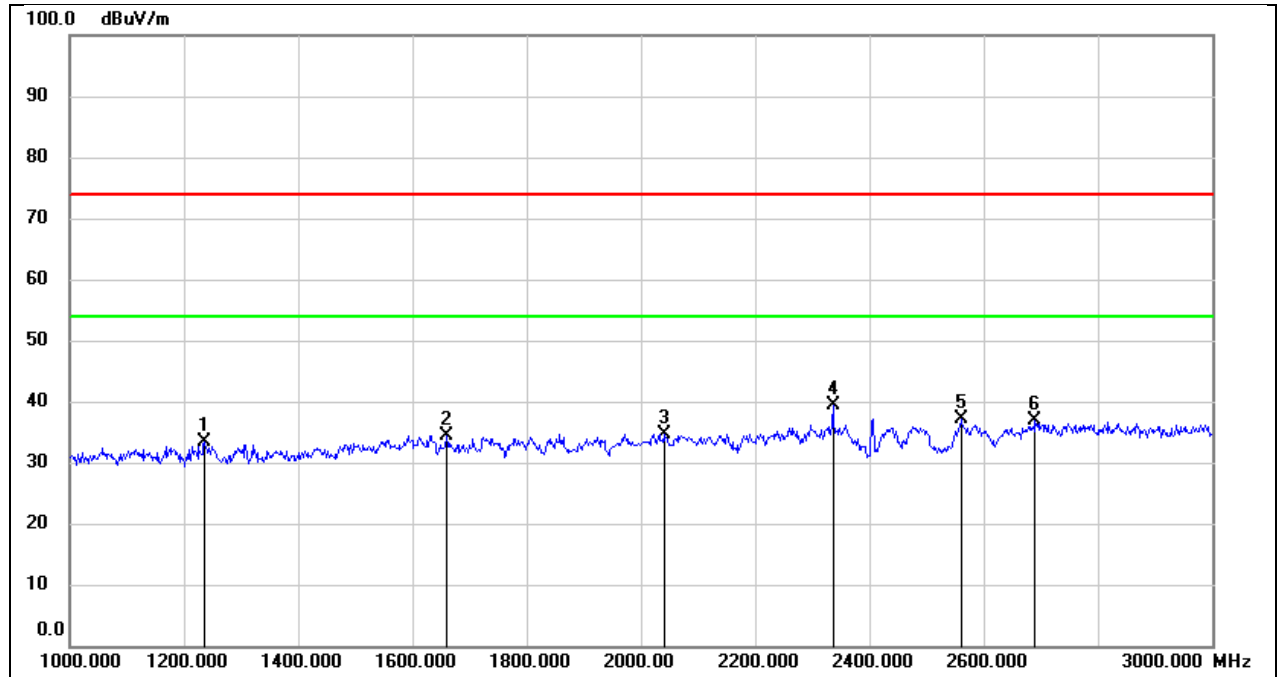

No.	Frequency (MHz)	Reading (dBuV)	Correct (dB/m)	Result (dBuV/m)	Limit (dBuV/m)	Margin (dB)	Remark
1	1236.000	46.09	-12.60	33.49	74.00	-40.51	peak
2	1660.000	45.28	-10.89	34.39	74.00	-39.61	peak
3	2040.000	44.50	-9.87	34.63	74.00	-39.37	peak
4	2336.000	47.29	-7.87	39.42	74.00	-34.58	peak
5	2560.000	44.76	-7.61	37.15	74.00	-36.85	peak
6	2690.000	44.20	-7.29	36.91	74.00	-37.09	peak

Test Mode:	SRD 2.4GHz	Frequency(MHz):	2450
Polarity:	Horizontal	Test Voltage:	DC 5 V

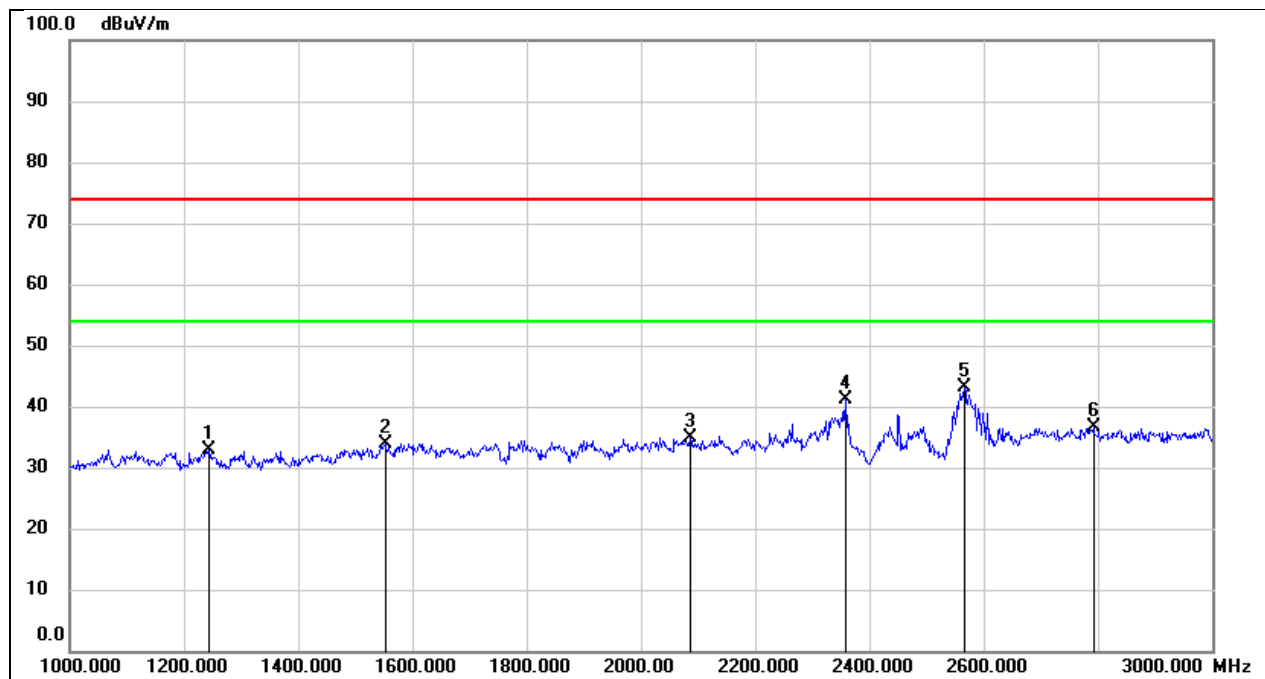

No.	Frequency (MHz)	Reading (dBuV)	Correct (dB/m)	Result (dBuV/m)	Limit (dBuV/m)	Margin (dB)	Remark
1	1244.000	45.42	-12.59	32.83	74.00	-41.17	peak
2	1552.000	45.40	-11.45	33.95	74.00	-40.05	peak
3	2086.000	44.36	-9.58	34.78	74.00	-39.22	peak
4	2358.000	48.80	-7.71	41.09	74.00	-32.91	peak
5	2566.000	50.67	-7.61	43.06	74.00	-30.94	peak
6	2792.000	43.45	-6.84	36.61	74.00	-37.39	peak

Test Mode:	SRD 2.4GHz	Frequency(MHz):	2450
Polarity:	Vertical	Test Voltage:	DC 5 V

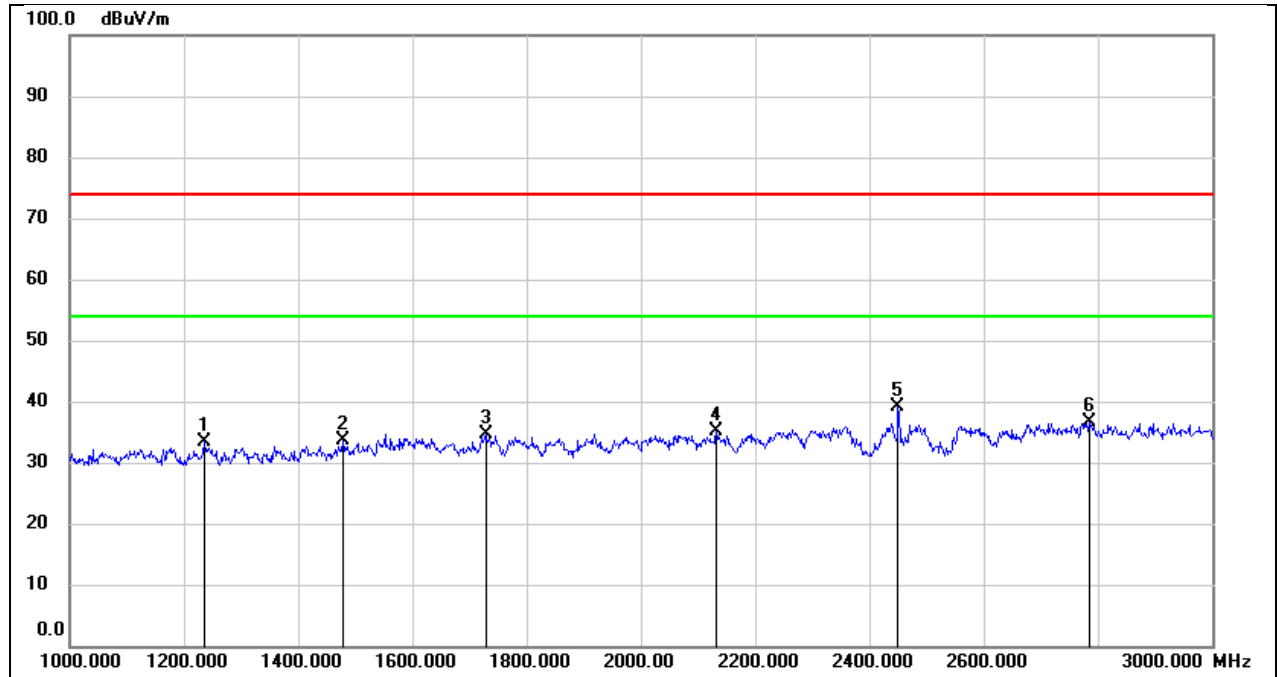

No.	Frequency (MHz)	Reading (dBuV)	Correct (dB/m)	Result (dBuV/m)	Limit (dBuV/m)	Margin (dB)	Remark
1	1236.000	45.98	-12.60	33.38	74.00	-40.62	peak
2	1478.000	45.40	-11.88	33.52	74.00	-40.48	peak
3	1728.000	45.22	-10.57	34.65	74.00	-39.35	peak
4	2132.000	44.48	-9.30	35.18	74.00	-38.82	peak
5	2450.000	46.66	-7.45	39.21	/	/	fundamental
6	2784.000	43.49	-6.87	36.62	74.00	-37.38	peak

Test Mode:	SRD 2.4GHz	Frequency(MHz):	2470
Polarity:	Horizontal	Test Voltage:	DC 5 V

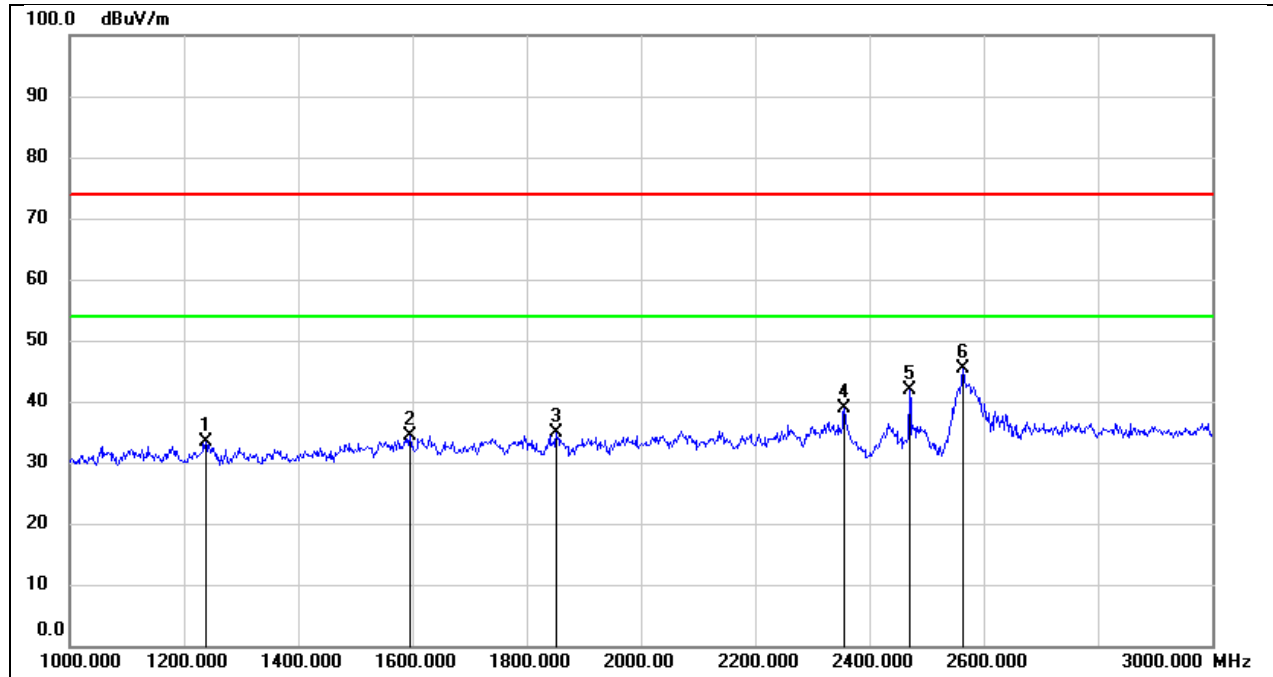

No.	Frequency (MHz)	Reading (dBuV)	Correct (dB/m)	Result (dBuV/m)	Limit (dBuV/m)	Margin (dB)	Remark
1	1238.000	45.96	-12.60	33.36	74.00	-40.64	peak
2	1596.000	45.54	-11.19	34.35	74.00	-39.65	peak
3	1852.000	44.98	-10.21	34.77	74.00	-39.23	peak
4	2356.000	46.52	-7.72	38.80	74.00	-35.20	peak
5	2470.000	49.24	-7.47	41.77	/	/	fundamental
6	2564.000	52.93	-7.62	45.31	74.00	-28.69	peak

Test Mode:	SRD 2.4GHz	Frequency(MHz):	2470
Polarity:	Vertical	Test Voltage:	DC 5 V

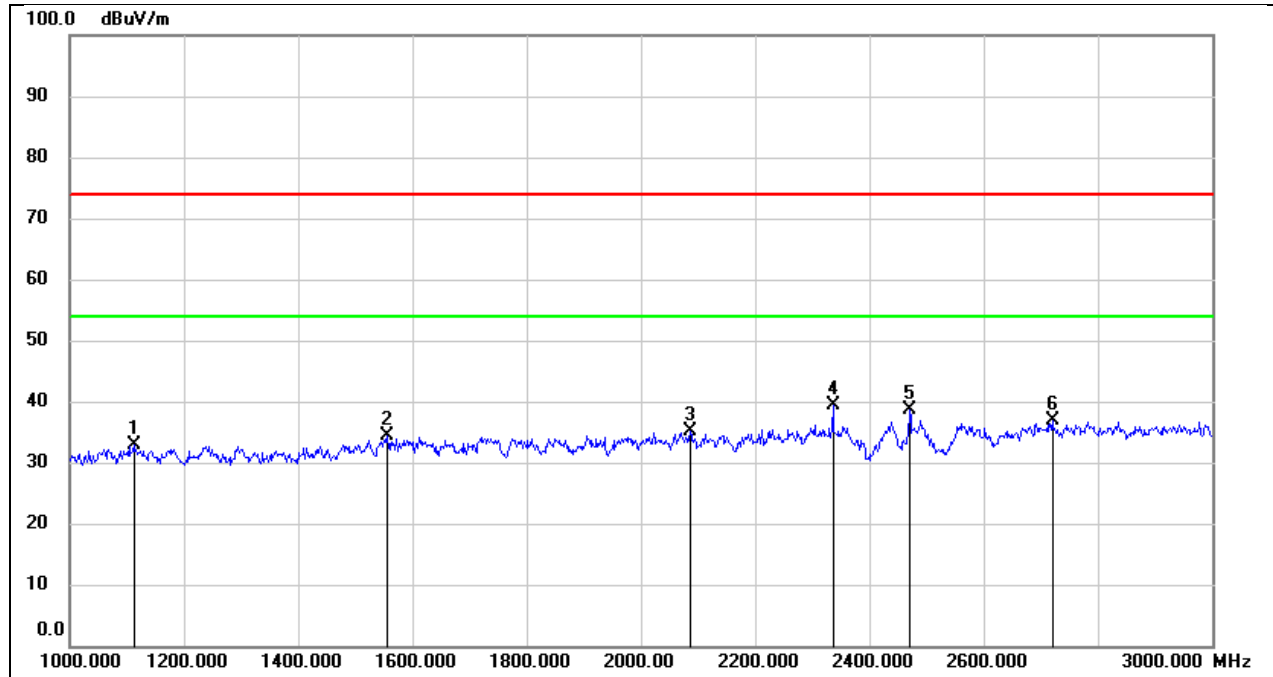

No.	Frequency (MHz)	Reading (dBuV)	Correct (dB/m)	Result (dBuV/m)	Limit (dBuV/m)	Margin (dB)	Remark
1	1112.000	46.34	-13.42	32.92	74.00	-41.08	peak
2	1556.000	45.72	-11.43	34.29	74.00	-39.71	peak
3	2086.000	44.76	-9.58	35.18	74.00	-38.82	peak
4	2336.000	47.18	-7.87	39.31	74.00	-34.69	peak
5	2470.000	46.21	-7.47	38.74	/	/	fundamental
6	2720.000	44.13	-7.15	36.98	74.00	-37.02	peak

8.3. SPURIOUS EMISSIONS (3 GHZ ~ 18 GHZ)

Test Mode:	SRD 2.4GHz	Frequency(MHz):	2405
Polarity:	Horizontal	Test Voltage:	DC 5 V

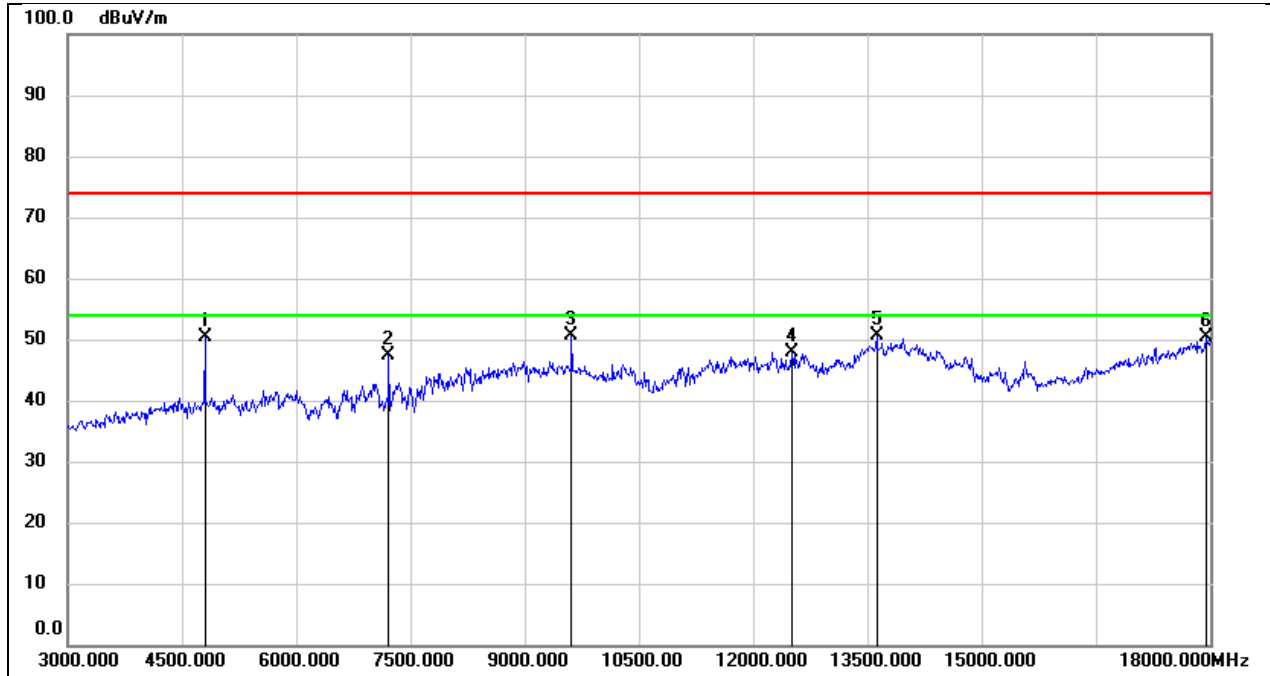

No.	Frequency (MHz)	Reading (dBuV)	Correct (dB/m)	Result (dBuV/m)	Limit (dBuV/m)	Margin (dB)	Remark
1	4800.000	49.82	0.46	50.28	74.00	-23.72	peak
2	7215.000	41.15	6.35	47.50	74.00	-26.50	peak
3	9615.000	39.44	11.10	50.54	74.00	-23.46	peak
4	12510.000	29.29	18.51	47.80	74.00	-26.20	peak
5	13620.000	28.82	21.76	50.58	74.00	-23.42	peak
6	17940.000	23.79	26.61	50.40	74.00	-23.60	peak

Test Mode:	SRD 2.4GHz	Frequency(MHz):	2405
Polarity:	Vertical	Test Voltage:	DC 5 V

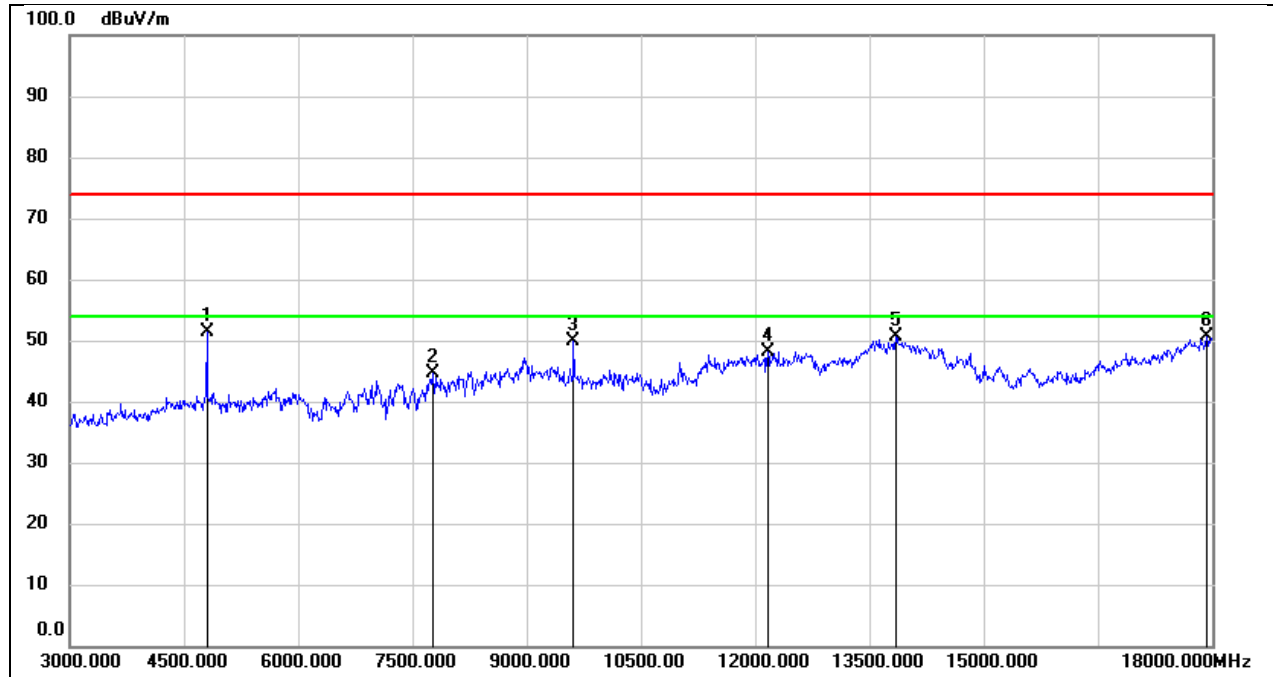

No.	Frequency (MHz)	Reading (dBuV)	Correct (dB/m)	Result (dBuV/m)	Limit (dBuV/m)	Margin (dB)	Remark
1	4800.000	50.86	0.46	51.32	74.00	-22.68	peak
2	7770.000	37.23	7.43	44.66	74.00	-29.34	peak
3	9615.000	38.88	11.10	49.98	74.00	-24.02	peak
4	12165.000	29.90	18.35	48.25	74.00	-25.75	peak
5	13845.000	27.85	22.67	50.52	74.00	-23.48	peak
6	17925.000	23.98	26.55	50.53	74.00	-23.47	peak

Test Mode:	SRD 2.4GHz	Frequency(MHz):	2450
Polarity:	Horizontal	Test Voltage:	DC 5 V

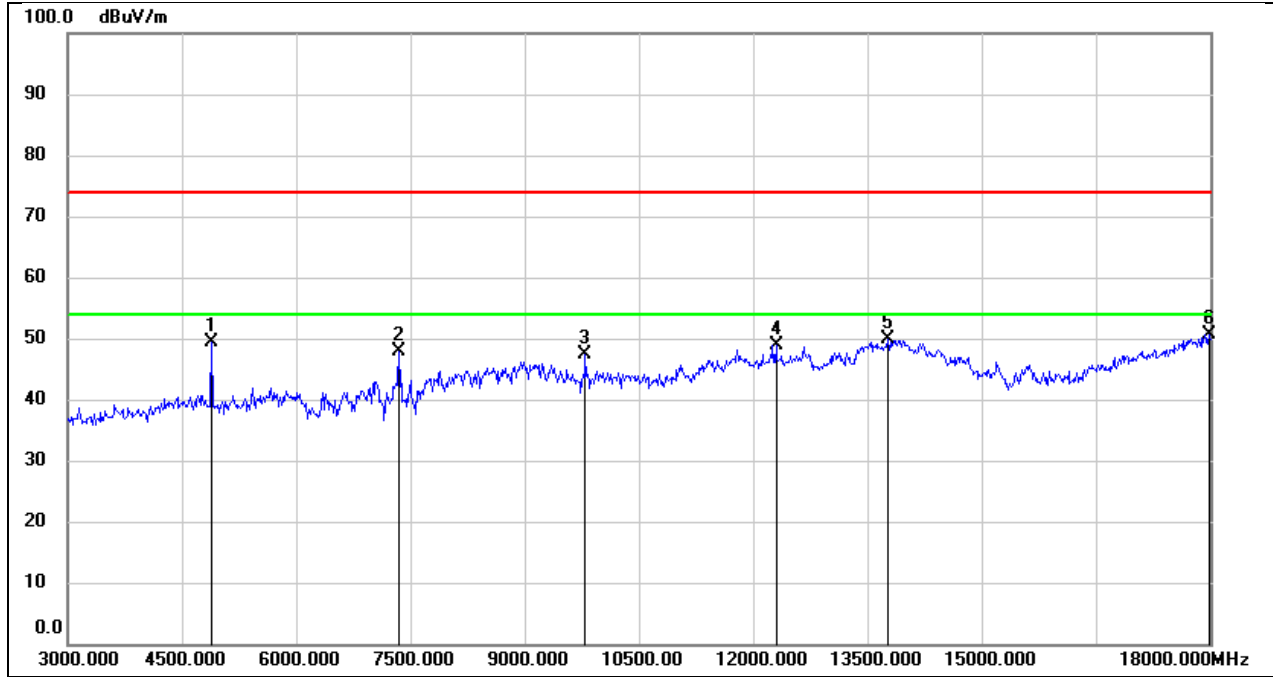

No.	Frequency (MHz)	Reading (dBuV)	Correct (dB/m)	Result (dBuV/m)	Limit (dBuV/m)	Margin (dB)	Remark
1	4890.000	48.71	0.64	49.35	74.00	-24.65	peak
2	7350.000	40.66	7.17	47.83	74.00	-26.17	peak
3	9795.000	35.79	11.51	47.30	74.00	-26.70	peak
4	12300.000	30.28	18.65	48.93	74.00	-25.07	peak
5	13770.000	27.28	22.49	49.77	74.00	-24.23	peak
6	17985.000	23.97	26.77	50.74	74.00	-23.26	peak

Test Mode:	SRD 2.4GHz	Frequency(MHz):	2450
Polarity:	Vertical	Test Voltage:	DC 5 V

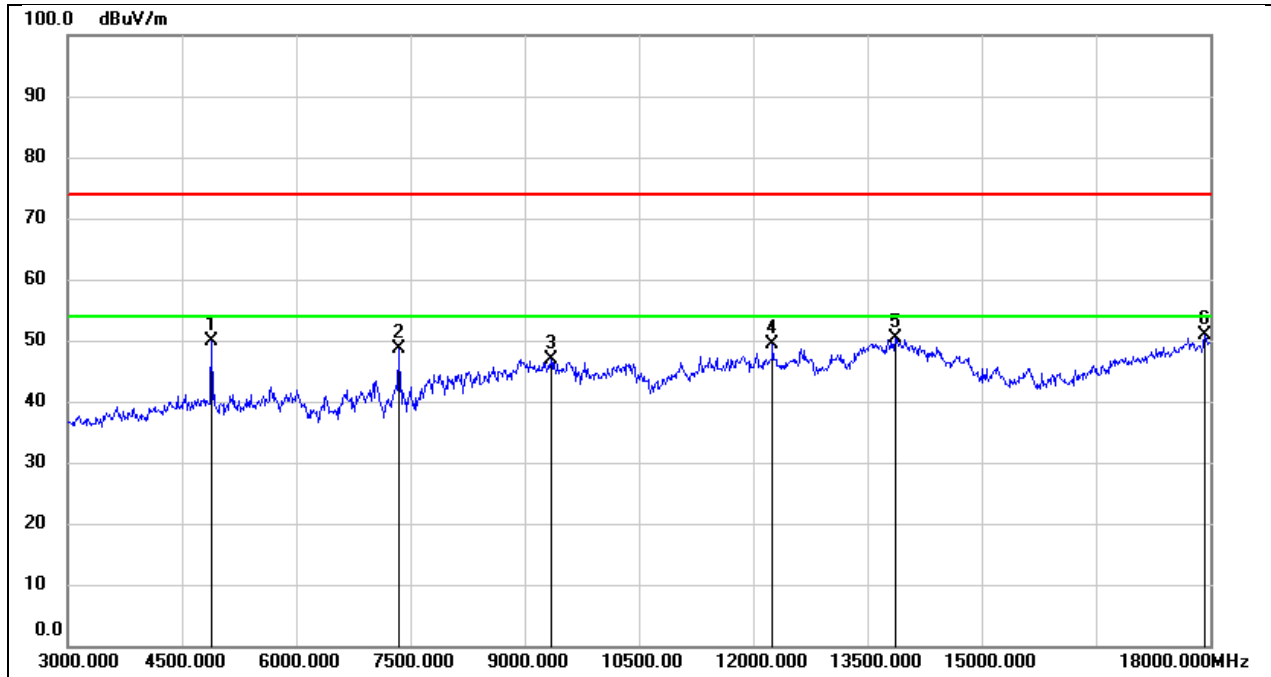

No.	Frequency (MHz)	Reading (dBuV)	Correct (dB/m)	Result (dBuV/m)	Limit (dBuV/m)	Margin (dB)	Remark
1	4890.000	49.30	0.64	49.94	74.00	-24.06	peak
2	7350.000	41.51	7.17	48.68	74.00	-25.32	peak
3	9345.000	36.65	10.32	46.97	74.00	-27.03	peak
4	12255.000	30.93	18.50	49.43	74.00	-24.57	peak
5	13860.000	27.60	22.68	50.28	74.00	-23.72	peak
6	17925.000	24.22	26.55	50.77	74.00	-23.23	peak

Test Mode:	SRD 2.4GHz	Frequency(MHz):	2470
Polarity:	Horizontal	Test Voltage:	DC 5 V

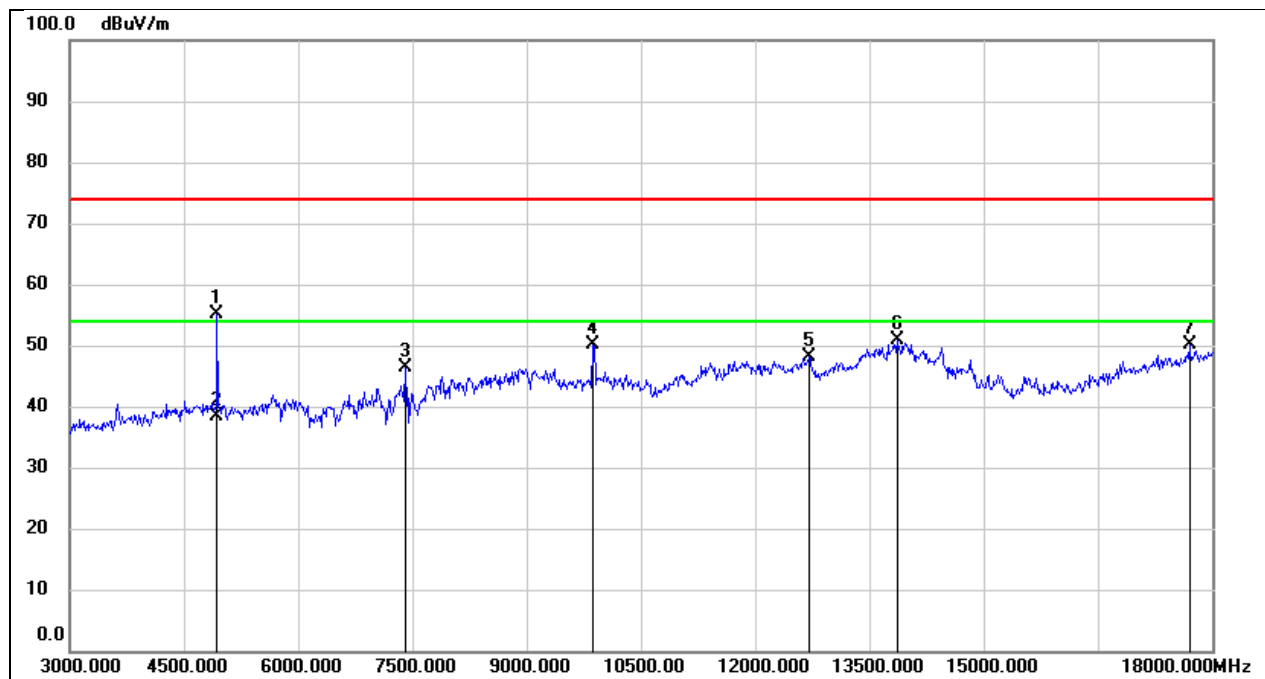

No.	Frequency (MHz)	Reading (dBuV)	Correct (dB/m)	Result (dBuV/m)	Limit (dBuV/m)	Margin (dB)	Remark
1	4935.000	54.39	0.71	55.10	74.00	-18.90	peak
2	4935.000	/	/	38.27	54.00	-15.73	AVG
3	7410.000	39.05	7.43	46.48	74.00	-27.52	peak
4	9870.000	38.22	11.86	50.08	74.00	-23.92	peak
5	12705.000	29.43	18.66	48.09	74.00	-25.91	peak
6	13860.000	28.27	22.68	50.95	74.00	-23.05	peak
7	17700.000	25.04	25.17	50.21	74.00	-23.79	peak

Test Mode:	SRD 2.4GHz	Frequency(MHz):	2470
Polarity:	Vertical	Test Voltage:	DC 5 V

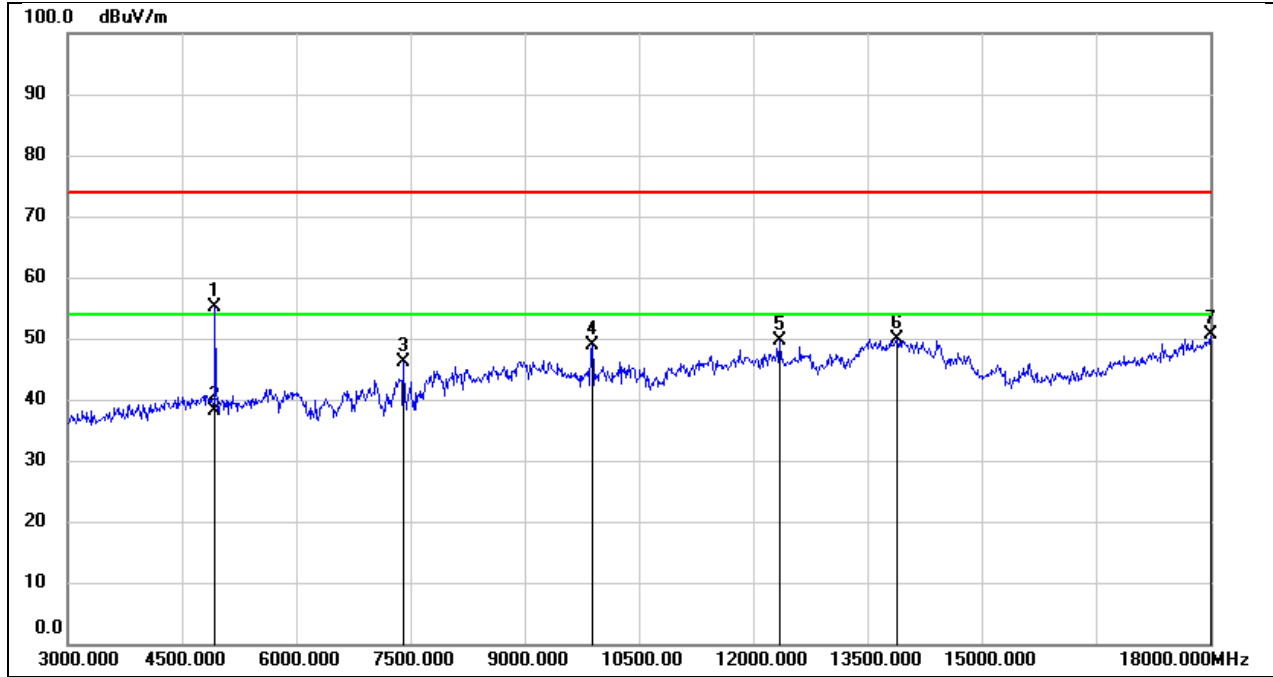

No.	Frequency (MHz)	Reading (dBuV)	Correct (dB/m)	Result (dBuV/m)	Limit (dBuV/m)	Margin (dB)	Remark
1	4935.000	54.30	0.71	55.01	74.00	-18.99	peak
2	4935.000	/	/	38.18	54.00	-15.82	AVG
3	7410.000	38.64	7.43	46.07	74.00	-27.93	peak
4	9885.000	37.08	11.92	49.00	74.00	-25.00	peak
5	12345.000	30.76	18.81	49.57	74.00	-24.43	peak
6	13890.000	27.30	22.69	49.99	74.00	-24.01	peak
7	18000.000	23.80	26.83	50.63	74.00	-23.37	peak

8.4. SPURIOUS EMISSIONS (9 KHZ ~ 30 MHZ)

Test Mode:	SRD 2.4GHz	Frequency(MHz):	2450
Polarity:	Loop Antenna Face On To The EUT	Test Voltage:	DC 5 V

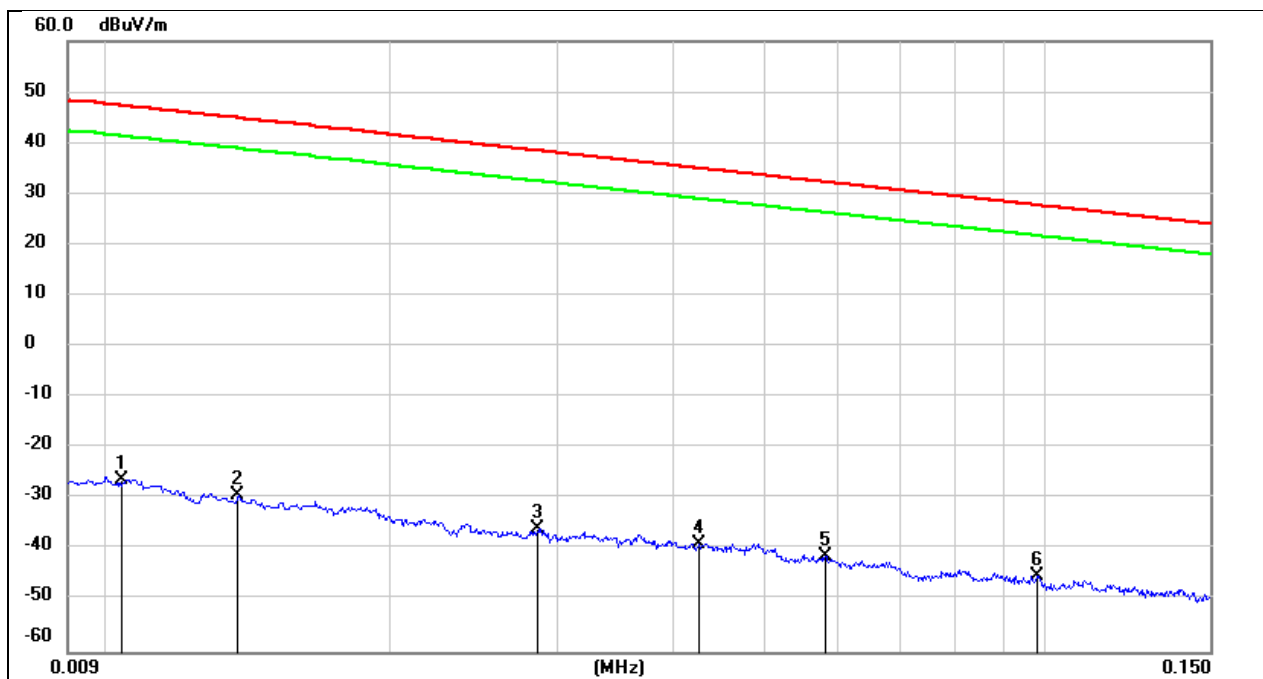

No.	Frequency (MHz)	Reading (dBuV)	Correct (dB/m)	FCC Result (dBuV/m)	FCC Limit (dBuV/m)	ISED Result (dBuA/m)	ISED Limit (dBuA/m)	Margin (dB)	Remark
1	0.0103	75.14	-101.40	-26.26	47.34	-77.76	-4.16	-73.60	peak
2	0.0137	72.22	-101.38	-29.16	44.87	-80.66	-6.63	-74.03	peak
3	0.0286	65.46	-101.38	-35.92	38.47	-87.42	-13.03	-74.39	peak
4	0.0427	62.64	-101.45	-38.81	34.99	-90.31	-16.51	-73.80	peak
5	0.0582	60.26	-101.51	-41.25	32.30	-92.75	-19.20	-73.55	peak
6	0.0981	56.77	-101.78	-45.01	27.77	-96.51	-23.73	-72.78	peak

Test Mode:	SRD 2.4GHz	Frequency(MHz):	2450
Polarity:	Loop Antenna Face On To The EUT	Test Voltage:	DC 5 V

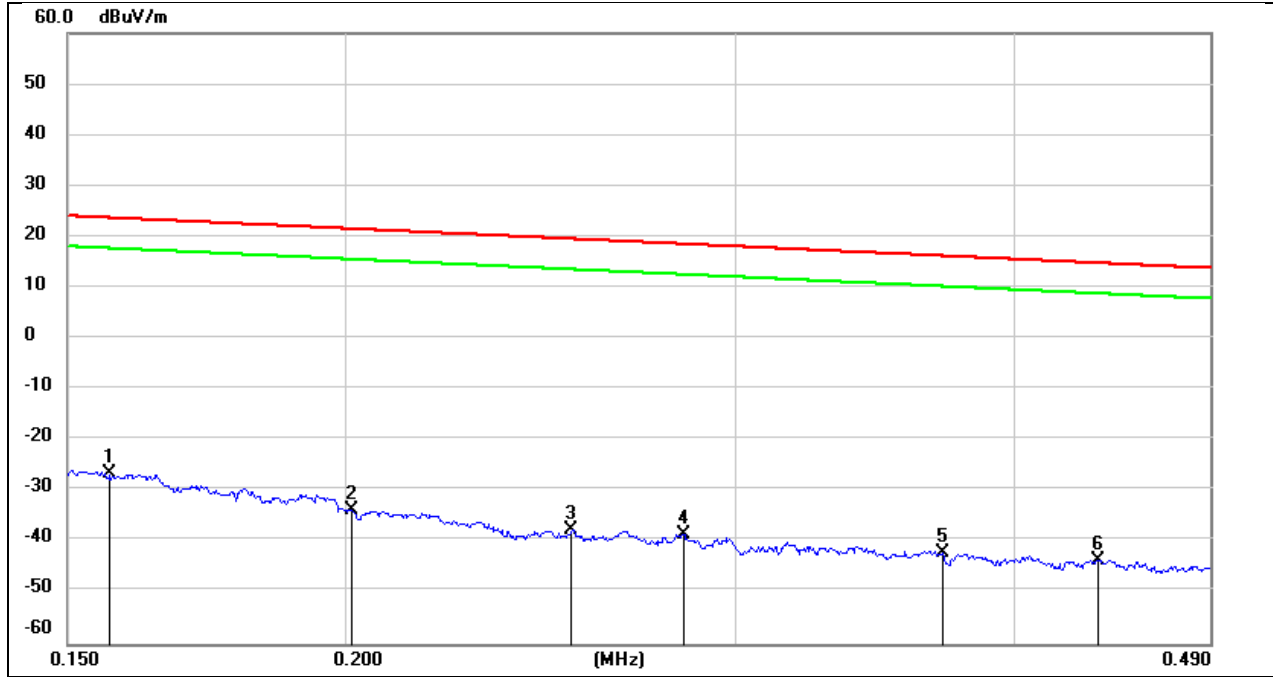

No.	Frequency (MHz)	Reading (dBuV)	Correct (dB/m)	FCC Result (dBuV/m)	FCC Limit (dBuV/m)	ISED Result (dBuA/m)	ISED Limit (dBuA/m)	Margin (dB)	Remark
1	0.1567	74.95	-101.65	-26.70	23.70	-78.20	-27.80	-50.40	peak
2	0.2013	68.06	-101.72	-33.66	21.52	-85.16	-29.98	-55.18	peak
3	0.2530	64.14	-101.80	-37.66	19.54	-89.16	-31.96	-57.20	peak
4	0.2837	63.22	-101.83	-38.61	18.54	-90.11	-32.96	-57.15	peak
5	0.3714	59.78	-101.93	-42.15	16.20	-93.65	-35.30	-58.35	peak
6	0.4364	58.36	-101.99	-43.63	14.80	-95.13	-36.70	-58.43	peak

Test Mode:	SRD 2.4GHz	Frequency(MHz):	2450
Polarity:	Loop Antenna Face On To The EUT	Test Voltage:	DC 5 V

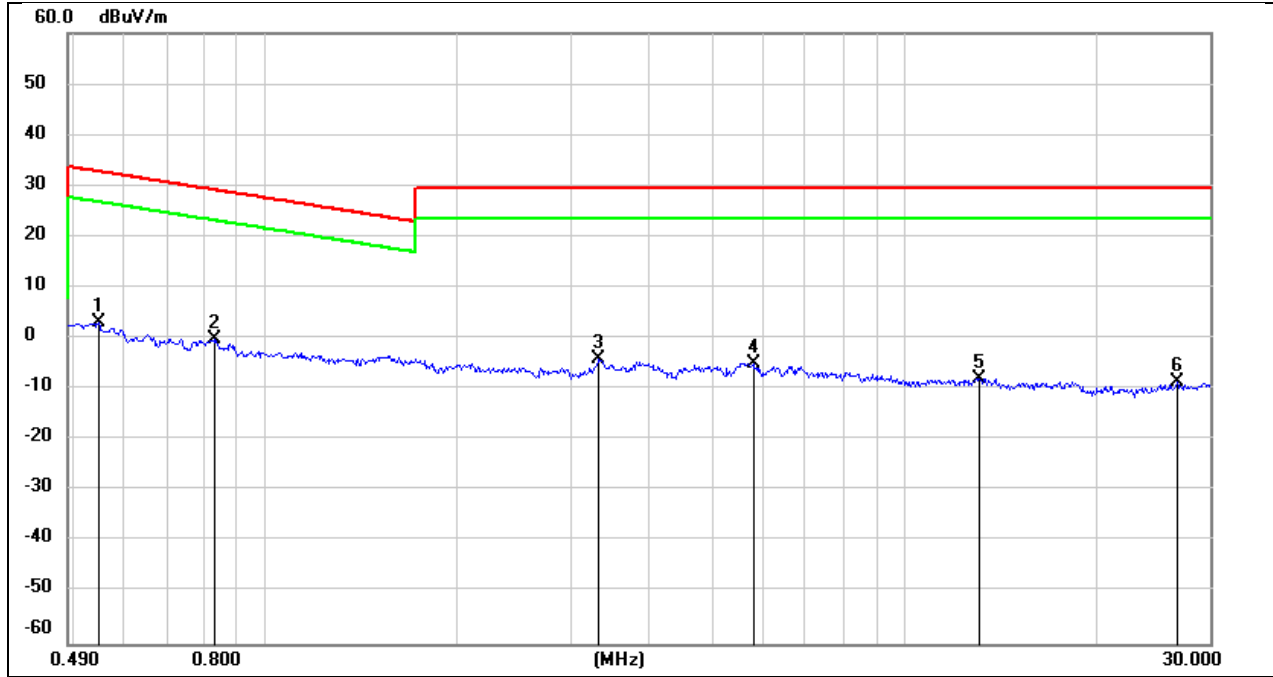

No.	Frequency (MHz)	Reading (dBuV)	Correct (dB/m)	FCC Result (dBuV/m)	FCC Limit (dBuV/m)	ISED Result (dBuA/m)	ISED Limit (dBuA/m)	Margin (dB)	Remark
1	0.5490	65.34	-62.08	3.26	32.81	-48.24	-18.69	-29.55	peak
2	0.8296	61.94	-62.17	-0.23	29.23	-51.73	-22.27	-29.46	peak
3	3.3229	57.39	-61.50	-4.11	29.54	-55.61	-21.96	-33.65	peak
4	5.8018	56.41	-61.38	-4.97	29.54	-56.47	-21.96	-34.51	peak
5	13.0907	53.13	-60.93	-7.80	29.54	-59.30	-21.96	-37.34	peak
6	26.6949	51.71	-60.29	-8.58	29.54	-60.08	-21.96	-38.12	peak

8.5. SPURIOUS EMISSIONS (30 MHz ~ 1 GHz)

Test Mode:	SRD 2.4GHz	Frequency(MHz):	2450
Polarity:	Horizontal	Test Voltage:	DC 5 V

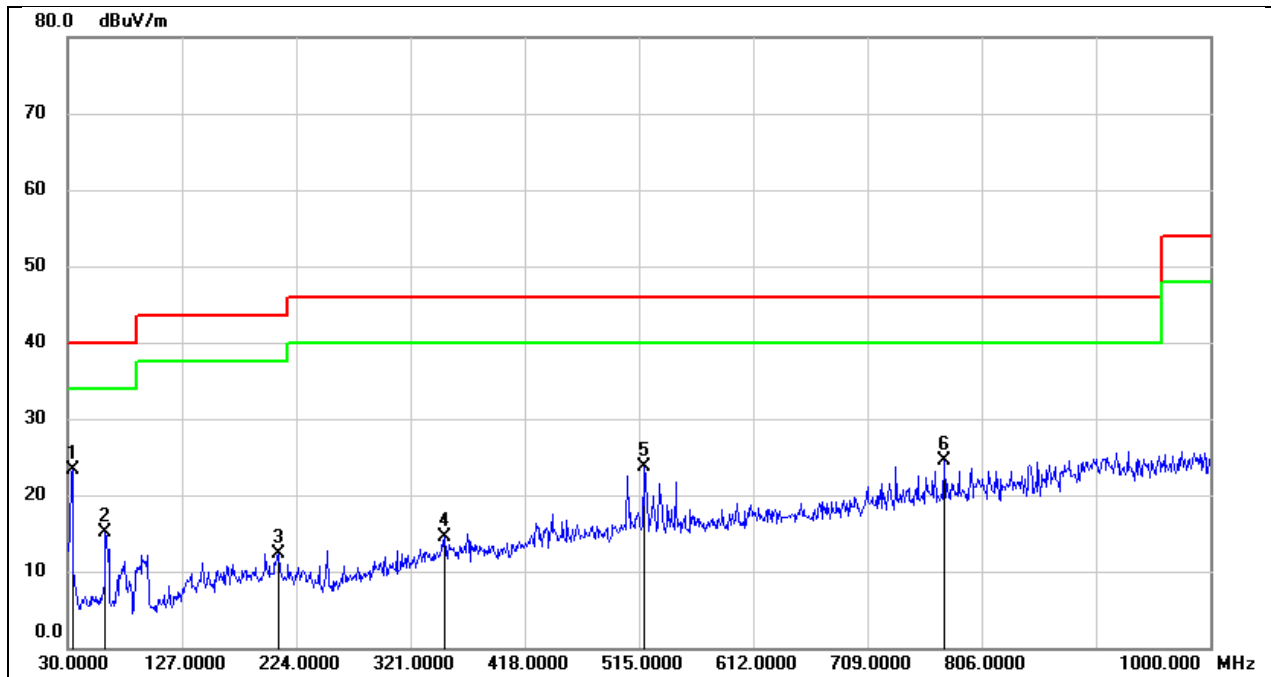

No.	Frequency (MHz)	Reading (dBuV)	Correct (dB/m)	Result (dBuV/m)	Limit (dBuV/m)	Margin (dB)	Remark
1	33.8800	37.91	-14.61	23.30	40.00	-16.70	QP
2	62.0100	30.26	-15.24	15.02	40.00	-24.98	QP
3	208.4800	24.85	-12.53	12.32	43.50	-31.18	QP
4	350.1000	24.06	-9.58	14.48	46.00	-31.52	QP
5	518.8800	31.63	-7.85	23.78	46.00	-22.22	QP
6	773.9900	27.85	-3.33	24.52	46.00	-21.48	QP

Test Mode:	SRD 2.4GHz	Frequency(MHz):	2450
Polarity:	Vertical	Test Voltage:	DC 5 V

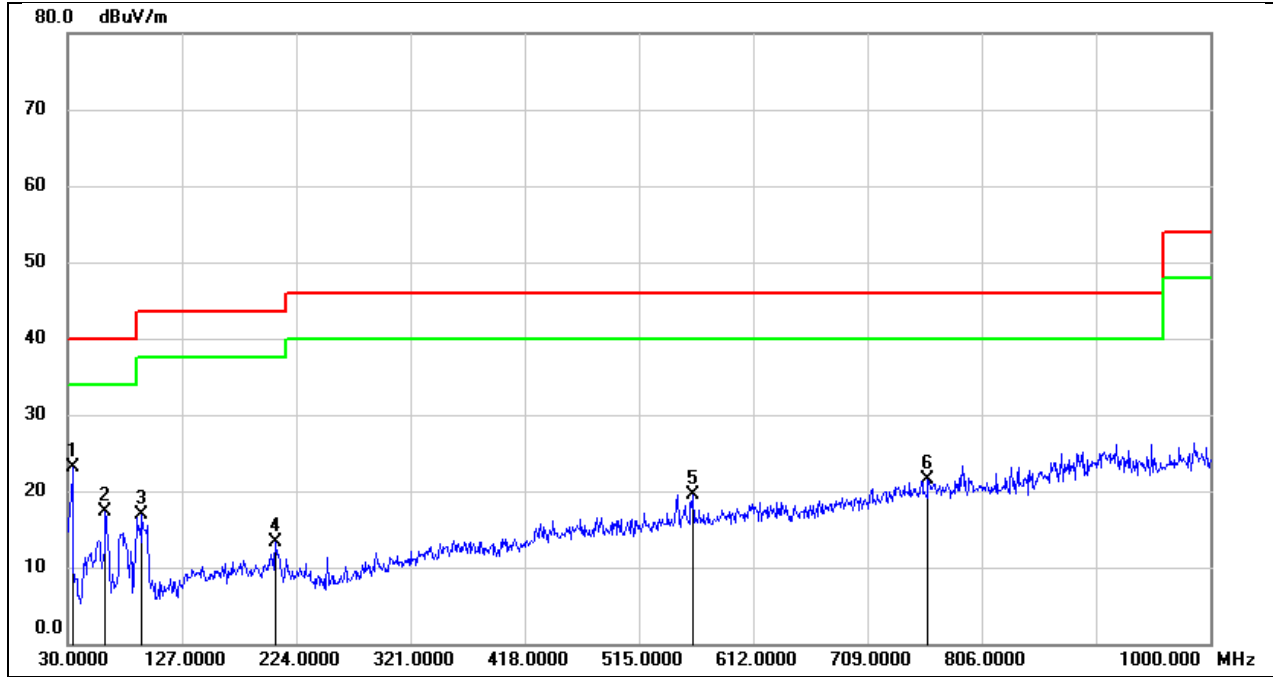

No.	Frequency (MHz)	Reading (dBuV)	Correct (dB/m)	Result (dBuV/m)	Limit (dBuV/m)	Margin (dB)	Remark
1	33.8800	37.77	-14.61	23.16	40.00	-16.84	QP
2	62.0100	32.48	-15.24	17.24	40.00	-22.76	QP
3	93.0500	33.61	-16.71	16.90	43.50	-26.60	QP
4	206.5399	25.82	-12.47	13.35	43.50	-30.15	QP
5	560.5900	26.67	-7.14	19.53	46.00	-26.47	QP
6	760.4099	24.85	-3.37	21.48	46.00	-24.52	QP

8.6. SPURIOUS EMISSIONS (18 GHZ ~ 26 GHZ)

Test Mode:	SRD 2.4GHz	Frequency(MHz):	2450
Polarity:	Horizontal	Test Voltage:	DC 5 V

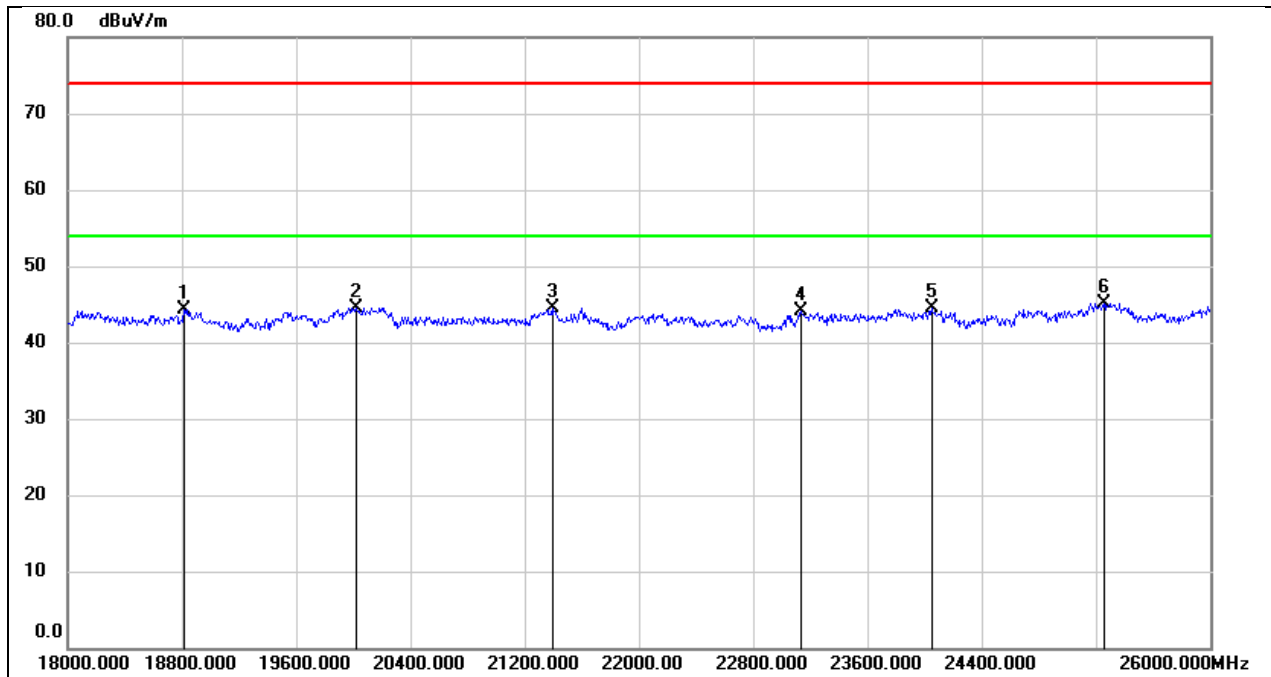

No.	Frequency (MHz)	Reading (dBuV)	Correct (dB/m)	Result (dBuV/m)	Limit (dBuV/m)	Margin (dB)	Remark
1	18816.000	49.71	-5.38	44.33	74.00	-29.67	peak
2	20016.000	50.06	-5.47	44.59	74.00	-29.41	peak
3	21392.000	49.23	-4.72	44.51	74.00	-29.49	peak
4	23136.000	47.43	-3.40	44.03	74.00	-29.97	peak
5	24048.000	47.22	-2.76	44.46	74.00	-29.54	peak
6	25256.000	46.79	-1.67	45.12	74.00	-28.88	peak

Test Mode:	SRD 2.4GHz	Frequency(MHz):	2450
Polarity:	Vertical	Test Voltage:	DC 5 V

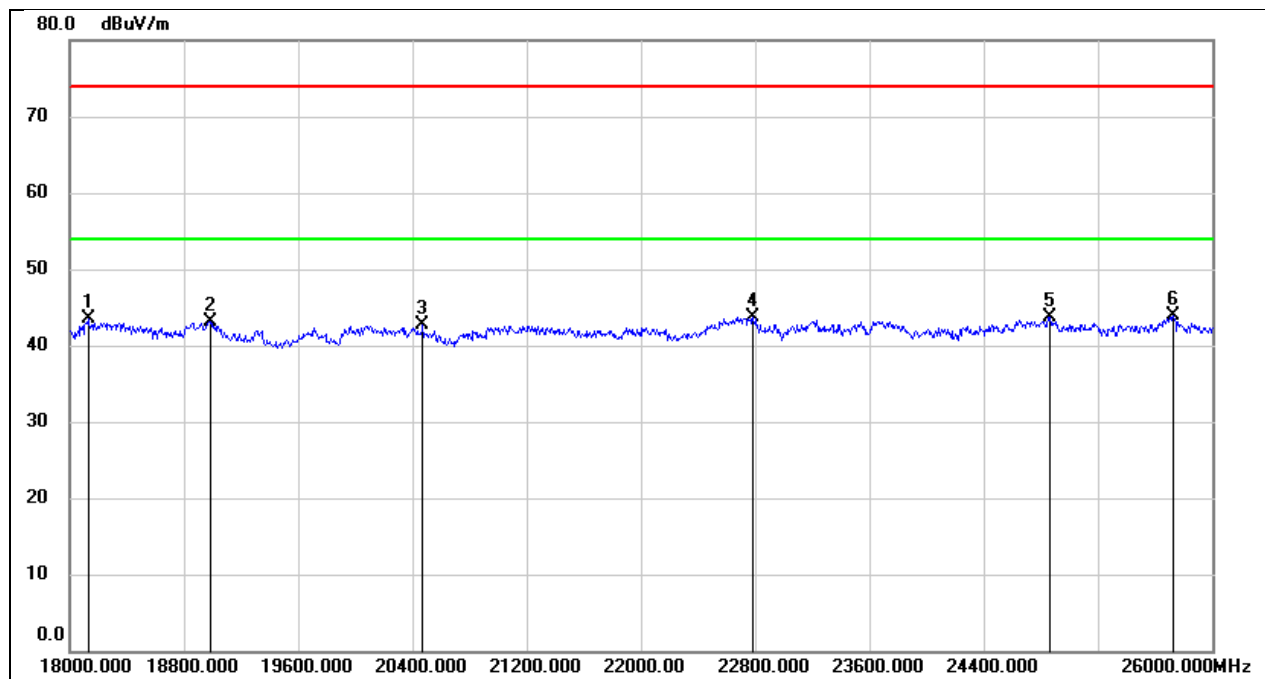

No.	Frequency (MHz)	Reading (dBuV)	Correct (dB/m)	Result (dBuV/m)	Limit (dBuV/m)	Margin (dB)	Remark
1	18128.000	48.94	-5.47	43.47	74.00	-30.53	peak
2	18984.000	48.29	-5.23	43.06	74.00	-30.94	peak
3	20472.000	48.07	-5.39	42.68	74.00	-31.32	peak
4	22784.000	47.27	-3.65	43.62	74.00	-30.38	peak
5	24864.000	46.03	-2.23	43.80	74.00	-30.20	peak
6	25728.000	44.61	-0.72	43.89	74.00	-30.11	peak

9. AC POWER LINE CONDUCTED EMISSION

LIMITS

Please refer to CFR 47 FCC §15.207 (a) and ISED RSS-Gen Clause 8.8

FREQUENCY (MHz)	Quasi-peak	Average
0.15 -0.5	66 - 56 *	56 - 46 *
0.50 -5.0	56.00	46.00
5.0 -30.0	60.00	50.00

TEST PROCEDURE

The EUT is put on a table of non-conducting material that is 80 cm high. The vertical conducting wall of shielding is located 40 cm to the rear of the EUT. The power line of the EUT is connected to the AC mains through a Artificial Mains Network (A.M.N.). A EMI Measurement Receiver (R&S Test Receiver ESR3) is used to test the emissions from both sides of AC line. According to the requirements in Section 6.2 of ANSI C63.10-2013. Conducted emissions from the EUT measured in the frequency range between 0.15 MHz and 30 MHz using CISPR Quasi-Peak and average detector mode. The bandwidth of EMI test receiver is set at 9 kHz.

The arrangement of the equipment is installed to meet the standards and operating in a manner, which tends to maximize its emission characteristics in a normal application.

TEST SETUP

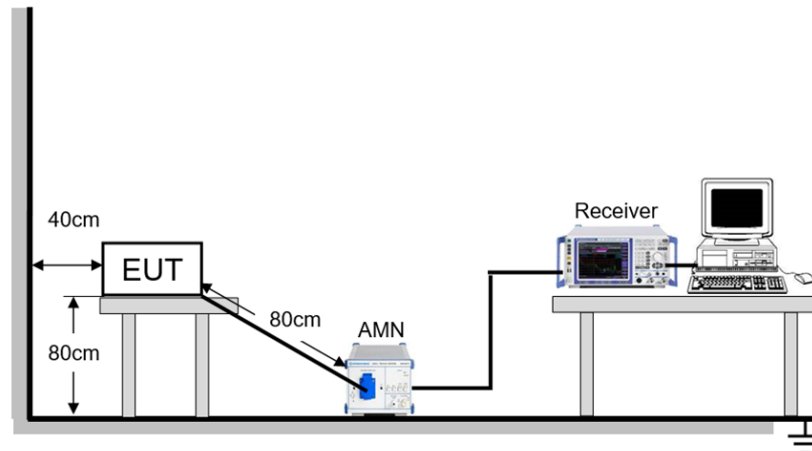

TEST ENVIRONMENT

Temperature	23.1°C	Relative Humidity	61%
Atmosphere Pressure	101kPa	Test Voltage	AC 120 V, 60 Hz

TEST RESULTS

Test Mode:	SRD 2.4GHz	Frequency(MHz):	2450
Line:	Line		

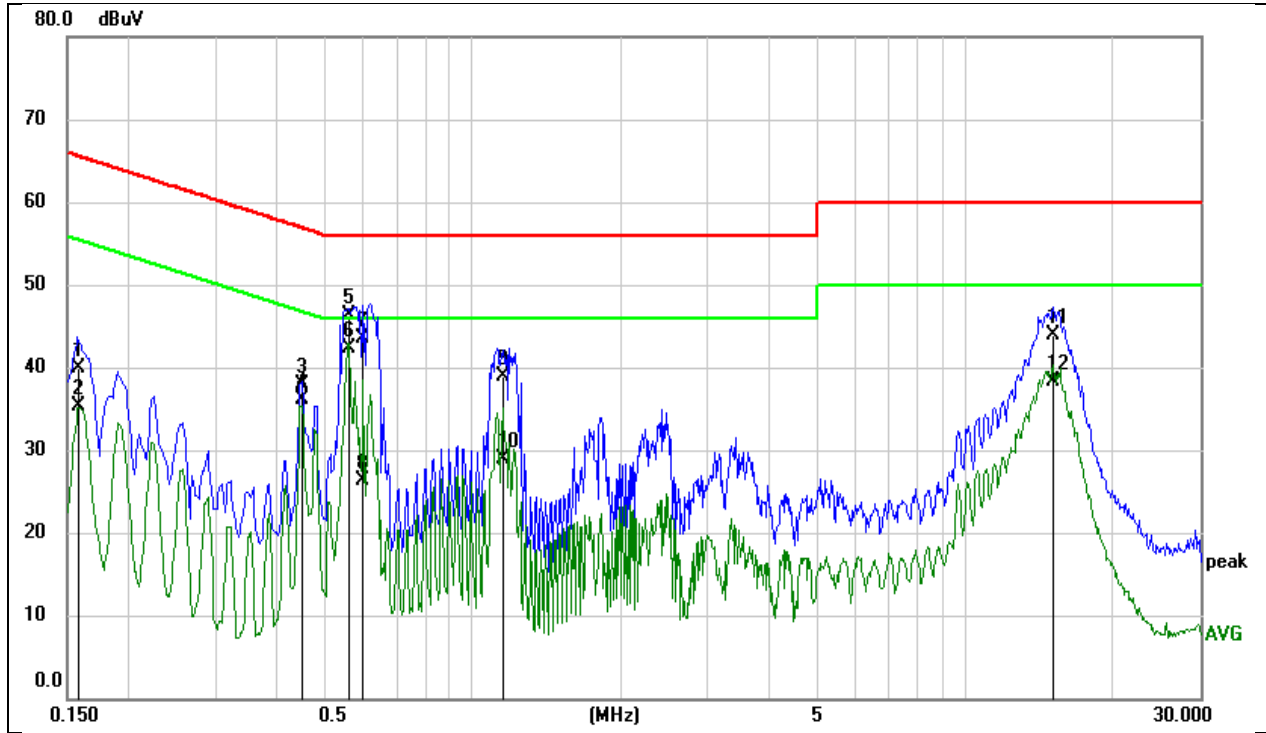

No.	Frequency (MHz)	Reading (dBuV)	Correct (dB)	Result (dBuV)	Limit (dBuV)	Margin (dB)	Remark
1	0.1586	29.53	10.32	39.85	65.54	-25.69	QP
2	0.1586	24.90	10.32	35.22	55.54	-20.32	AVG
3	0.4476	27.67	10.24	37.91	56.92	-19.01	QP
4	0.4476	25.94	10.24	36.18	46.92	-10.74	AVG
5	0.5620	36.01	10.24	46.25	56.00	-9.75	QP
6	0.5620	32.16	10.24	42.40	46.00	-3.60	AVG
7	0.5995	33.29	10.24	43.53	56.00	-12.47	QP
8	0.5995	16.03	10.24	26.27	46.00	-19.73	AVG
9	1.1533	28.86	10.01	38.87	56.00	-17.13	QP
10	1.1533	18.96	10.01	28.97	46.00	-17.03	AVG
11	15.0705	33.32	10.54	43.86	60.00	-16.14	QP
12	15.0705	27.69	10.54	38.23	50.00	-11.77	AVG

Note:

1. Result = Reading + Correct Factor.
2. If QP Result complies with AV limit, AV Result is deemed to comply with AV limit.
3. Test setup: RBW: 200 Hz (9 kHz ~ 150 kHz), 9 kHz (150 kHz ~ 30 MHz).
4. Step size: 80 Hz (0.009 MHz ~ 0.15 MHz), 4 kHz (0.15 MHz ~ 30 MHz), Scan time: auto.

Note: All the modes have been tested, only the worst data was recorded in the report.

Test Mode:	SRD 2.4GHz	Frequency(MHz):	2450
Line:	Neutral		

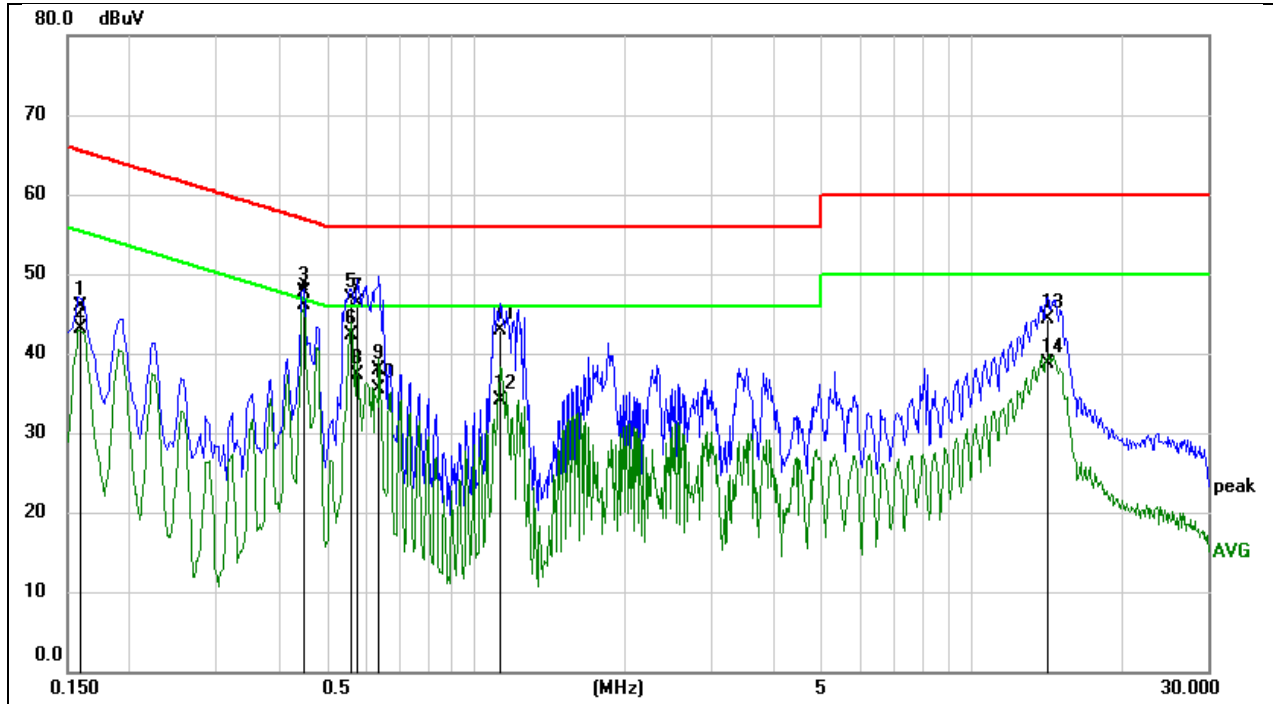

No.	Frequency (MHz)	Reading (dBuV)	Correct (dB)	Result (dBuV)	Limit (dBuV)	Margin (dB)	Remark
1	0.1595	35.69	10.22	45.91	65.49	-19.58	QP
2	0.1595	32.93	10.22	43.15	55.49	-12.34	AVG
3	0.4482	37.63	10.06	47.69	56.91	-9.22	QP
4	0.4482	36.02	10.06	46.08	46.91	-0.83	AVG
5	0.5620	36.88	10.04	46.92	56.00	-9.08	QP
6	0.5620	32.26	10.04	42.30	46.00	-3.70	AVG
7	0.5766	36.36	10.04	46.40	56.00	-9.60	QP
8	0.5766	27.21	10.04	37.25	46.00	-8.75	AVG
9	0.6392	27.83	10.03	37.86	56.00	-18.14	QP
10	0.6392	25.41	10.03	35.44	46.00	-10.56	AVG
11	1.1208	33.08	9.85	42.93	56.00	-13.07	QP
12	1.1208	24.35	9.85	34.20	46.00	-11.80	AVG
13	14.2417	33.69	10.61	44.30	60.00	-15.70	QP
14	14.2417	28.00	10.61	38.61	50.00	-11.39	AVG

Note:

1. Result = Reading + Correct Factor.
2. If QP Result complies with AV limit, AV Result is deemed to comply with AV limit.
3. Test setup: RBW: 200 Hz (9 kHz ~ 150 kHz), 9 kHz (150 kHz ~ 30 MHz).
4. Step size: 80 Hz (0.009 MHz ~ 0.15 MHz), 4 kHz (0.15 MHz ~ 30 MHz), Scan time: auto.

Note: All the modes have been tested, only the worst data was recorded in the report.

10. ANTENNA REQUIREMENT

REQUIREMENT

Please refer to FCC part 15.203

An intentional radiator shall be designed to ensure that no antenna other than that furnished by the responsible party shall be used with the device. The use of a permanently attached antenna or of an antenna that uses a unique coupling to the intentional radiator shall be considered sufficient to comply with the provisions of this section. The manufacturer may design the unit so that a broken antenna can be replaced by the user, but the use of a standard antenna jack or electrical connector is prohibited.

DESCRIPTION

Pass

END OF REPORT