



May 24, 2018

To: SGS North America Inc.
620 Old Peachtree Road
SUITE 100
Suwanee, Georgia
United States

Subject: **FCC Class II Permission Change Request for FCC ID: N82-KOHLER016**

Dear Sir/Madam,

This is to request a Class II Permission Change Request for FCC ID: N82-KOHLER016, originally granted on 01/07/2015

The Major different points under this application is rated power of power supply board from original 37.8W change to 218W, and add water pump. Refer to the appendix in details.

If you have any questions regarding this application, please free to contact me.

Sincerely,

A handwritten signature in black ink that reads "Timothy Stessman". The signature is written in a cursive style with a long horizontal flourish at the end.

Timothy Stessman
Staff Analyst
Kohler Co.

Appendix:

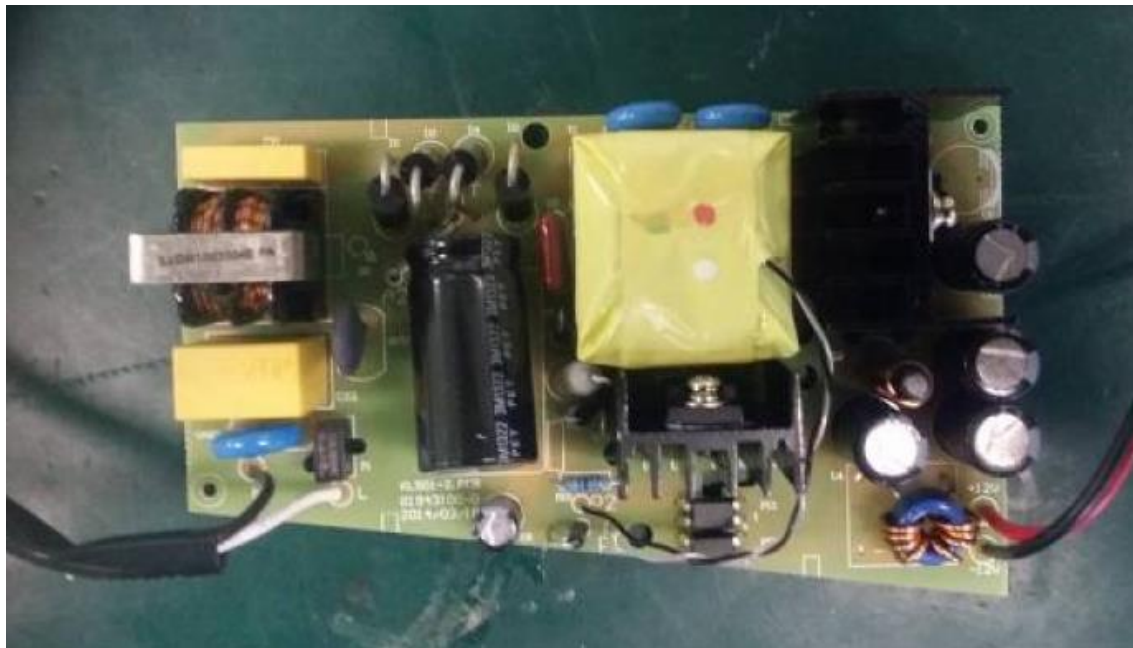

37.8W Power board using in K-5401

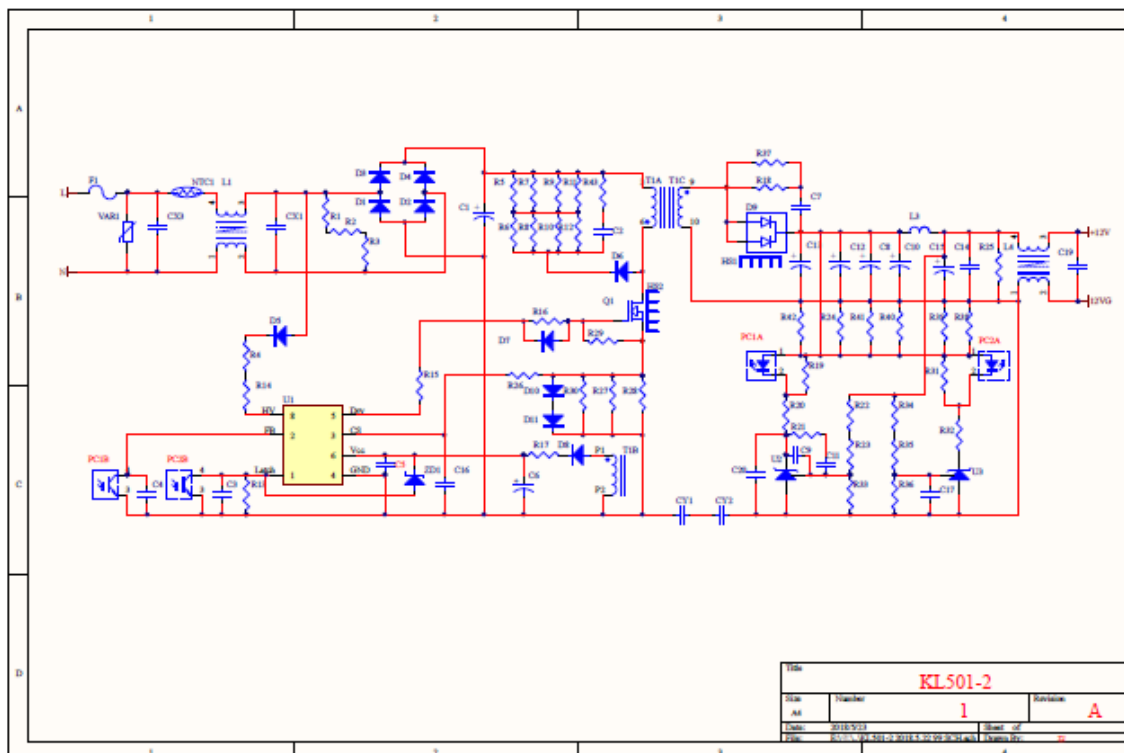

Schematics of 37.8W Power board



218W Power board using in K-5401-PA.

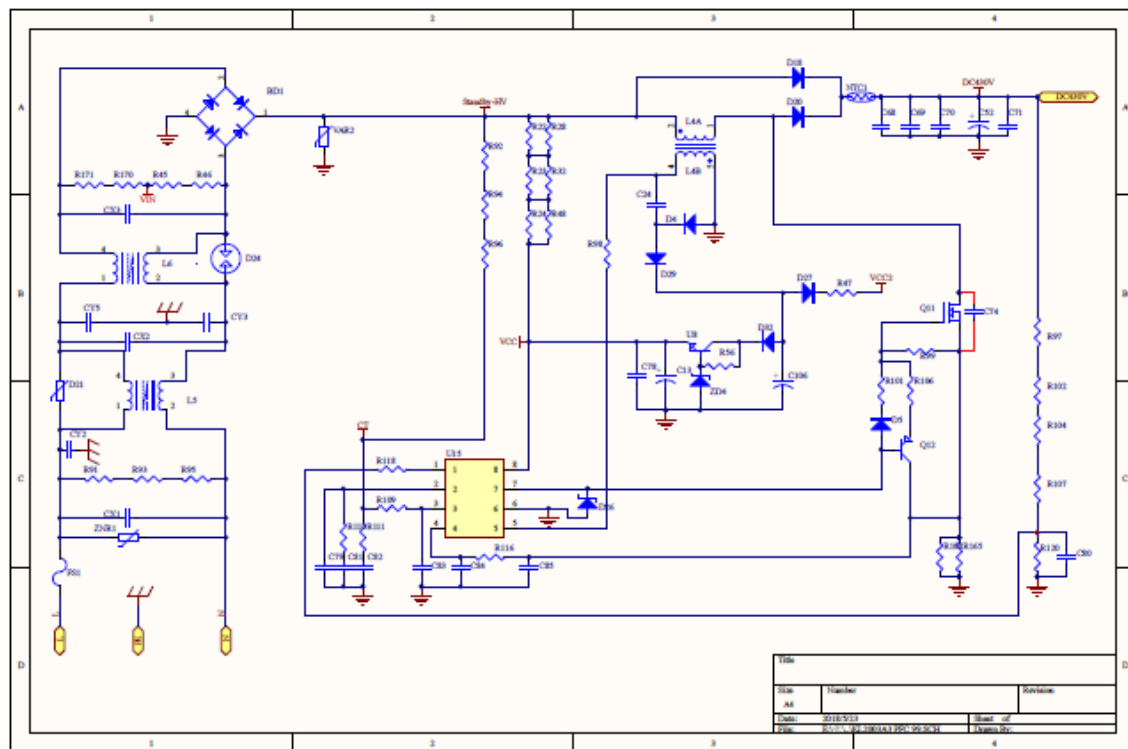

Schematics of 218W Power board

KOHLER



Add water pump.