

DRAWN: MARTIN	DATED: 30NOV2010	COMPANY: ARTCOM	
CHECKED:	DATED:	TITLE: AC601 NURSERY UNIT MAIN (BABY UNIT MAIN)	
QUALITY CONTROL:	DATED:	SCALE:	SIZE: A3
RELEASED:	DATED:	CODE:	DRAWING NO: REV: 0
			SHEET: 1 OF 1

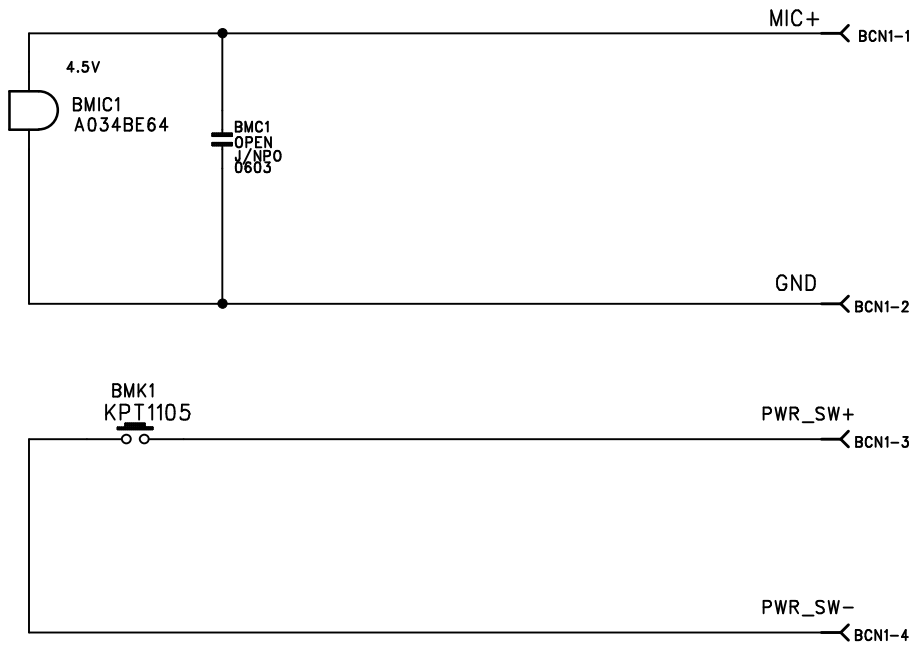

DRAWN: EFFIE	DATED: 30NOV2010	COMPANY: ARTCOM		
CHECKED:	DATED:	TITLE: AC601 NURSERY UNIT(MIC,POWER KEY)		
QUALITY CONTROL:	DATED:	SCALE:	SIZE:	REV: 0
RELEASED:	DATED:	CODE:	DRAWING NO:	SHEET: 1 OF 1

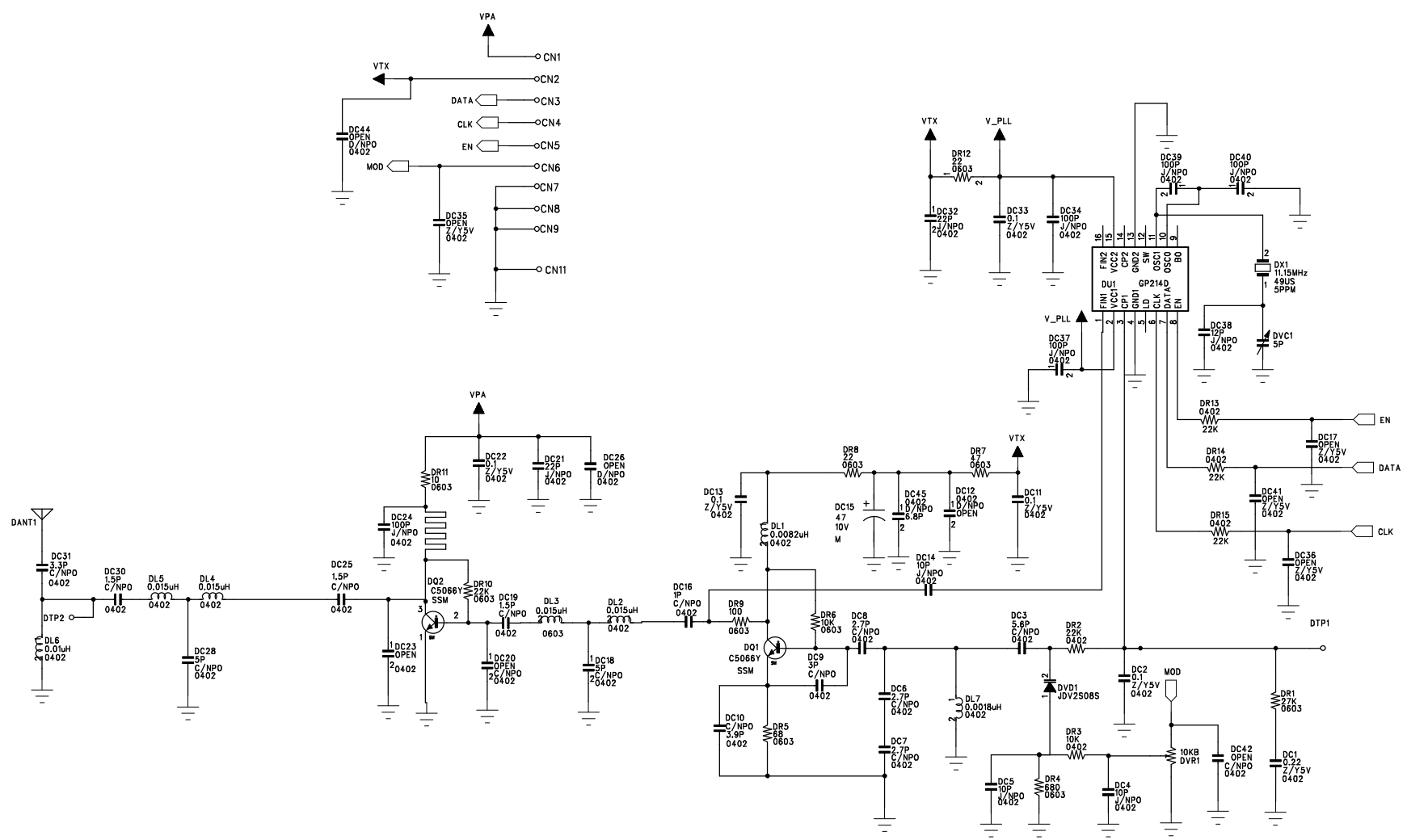

DRAWN: R&D HK	DATED: 30NOV2010	COMPANY: ARTCOM LIMITED
CHECKED:		TITLE: AC601 NURSERY US RF MODULE
QUALITY CONTROL:		PCB FILE: L O O J O O
RELEASED:	DATED:	SCALE: SIZE: A3 REV: 0
CODE:		DRAWING NO: SHEET: 1 OF 1