

mangOH Yellow Platform

- SHEET 1 BLOCK DIAGRAM
- SHEET 2 CF3
- SHEET 3 WIFI/BT, ANTENNA
- SHEET 4 RESET CIRCUITRY, CTRL SWITCH
- SHEET 5 SENSORS, I2C HUB, GPIO EXP
- SHEET 6 SD CARD, SIM,, IOT CONNECTOR
- SHEET 7 AUDIO, USB HUB, NFC, RTC
- SHEET 8 USB CONNECTORS, EXP CONN
- SHEET 9 BUCK CONVERTOR
- SHEET10 PSU, BATTERY CHARGER

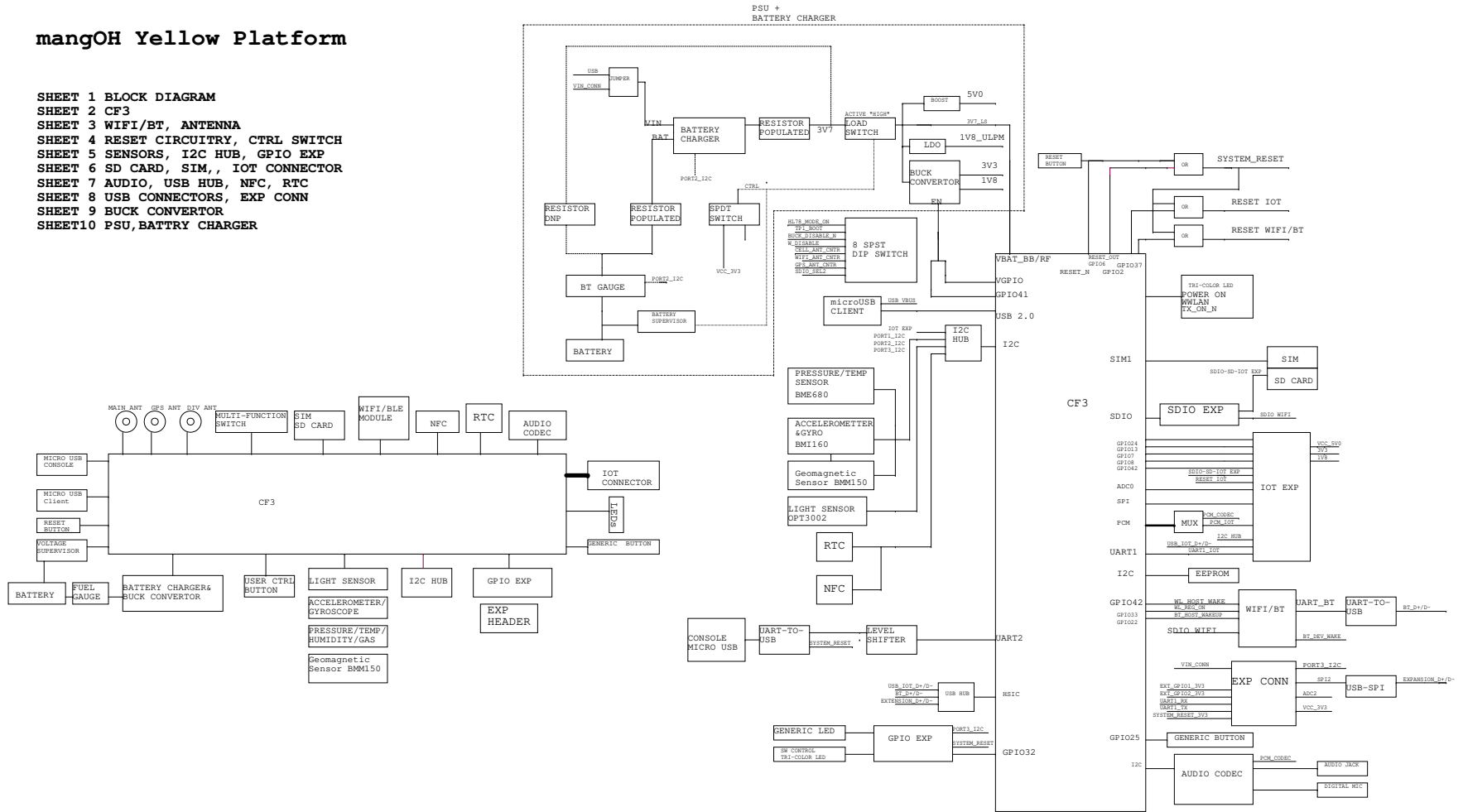

I2C ADDRESS LIST

- U200 EEPROM: 0x50
- U508 ACCE/GYRO: 0x18/68
- U507 BME680: 0x76
- U502 BMM150: 0x10/0x11
- U503 IO EXP: 0x3E
- U506 OPT3002: 0x44
- U505 TCA9546: 0x71 (same as 'red')
- U700 NT3H2211: 0x55 (default - can be changed)
- U701 PCF85063: 0x51
- U1000 BQ25601: 0x6B
- U1002 BQ27426: 0x55
- U703 USB3503A: 08h

PN	Description	REVISION
5303064	PCB, MANGO YELLOW	11
5303066	PCA, MANGO YELLOW	5
2142586	SCHEMATIC, MANGO YELLOW	21

<Variant Name>

This document contains information which is proprietary and confidential to Sierra Wireless Inc. Disclosure to Persons other than the officers, employees, agents or subcontractors of the company or licensee of this document without the prior written permission of Sierra Wireless Inc. is strictly prohibited.

Copyright (C) 2016



SITE
CTO Office

LEAD ENGINEER
Ashish Syal

DOCUMENT NUMBER 2142586	REV/SCH 21	REV/POS 11
PROJECT mangOH Yellow	SIZE Custom	
DATE Friday, July 26, 2019	SHEET 1	OF 10

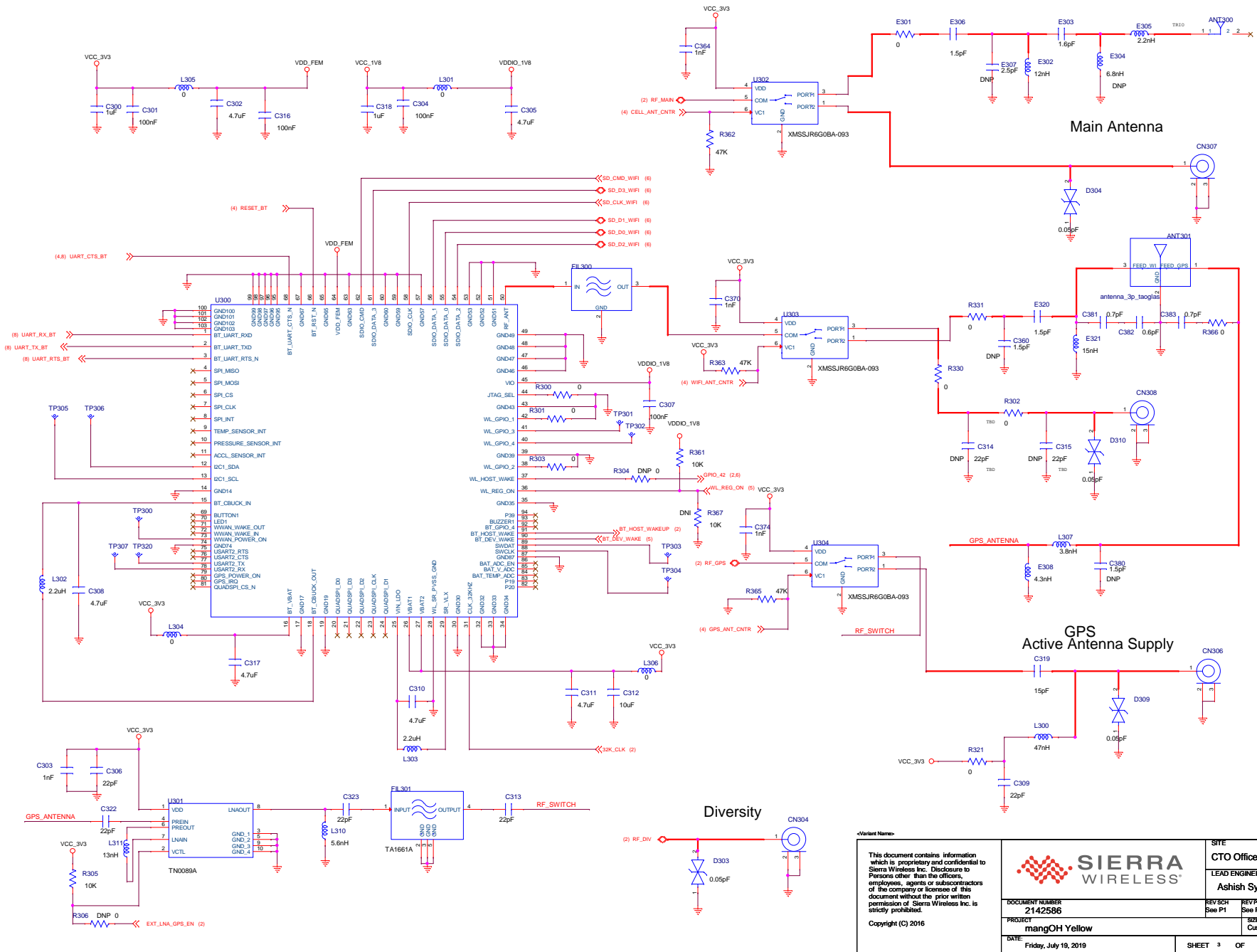

<Variant Name>
 This document contains information which is proprietary and confidential to Sierra Wireless Inc. Disclosure to Persons other than the officers, employees, agents or subcontractors of the company or licensee of this document without the prior written permission of Sierra Wireless Inc. is strictly prohibited.
 Copyright (C) 2016



DOCUMENT NUMBER 2142586	REV SCH See P1	REV PCB See P1
PROJECT mangOH Yellow	SHEET 3 OF 10	

SITE CTO Office
LEAD ENGINEER Ashish Syal
DATE Friday, July 19, 2016

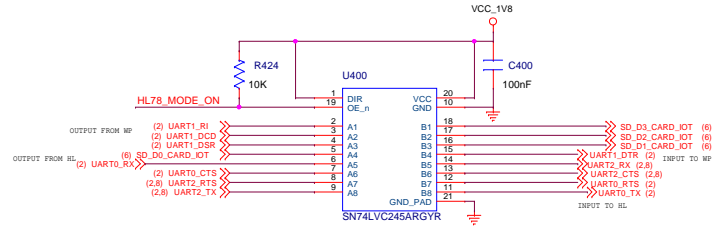
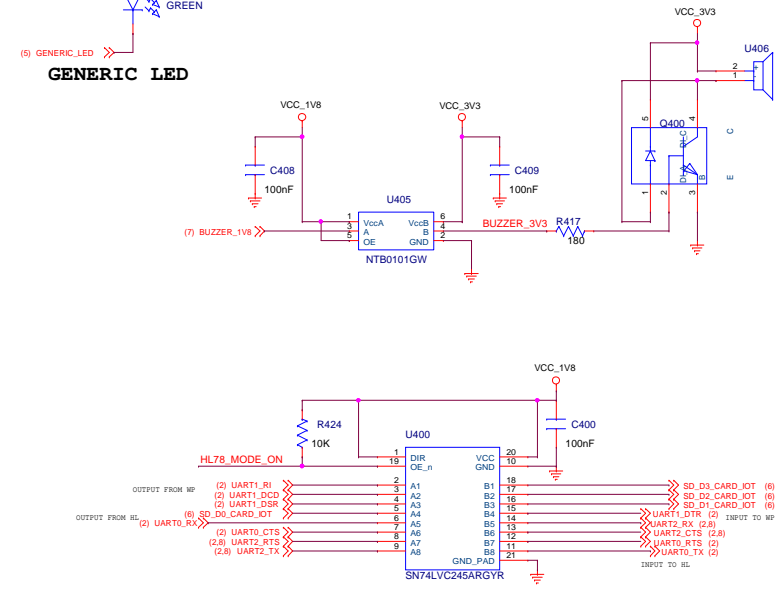
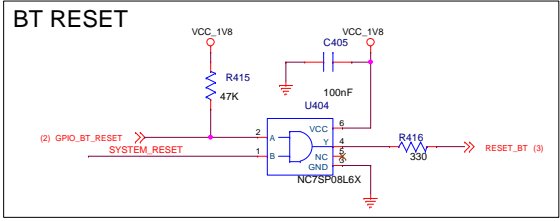
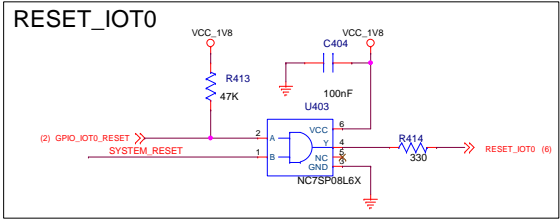
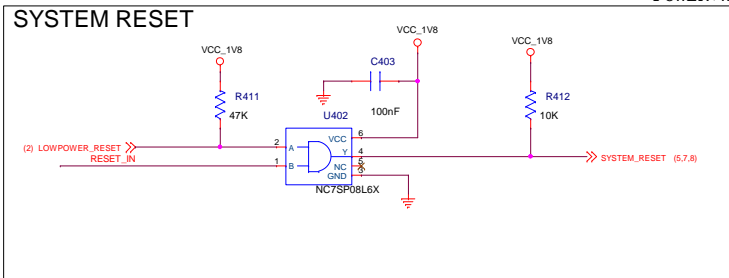
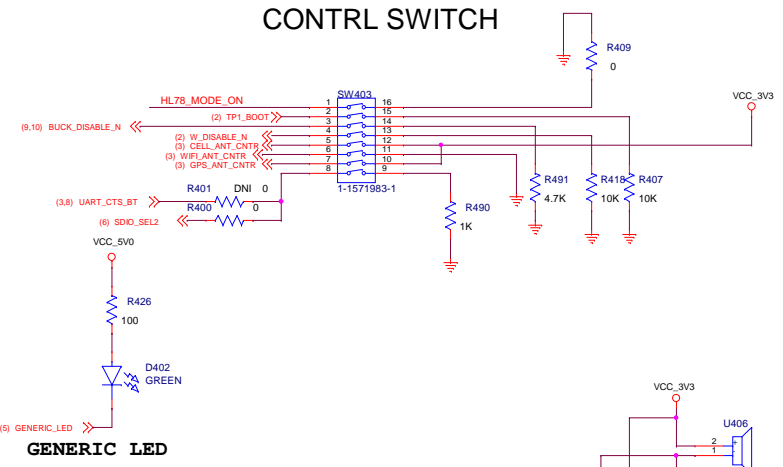
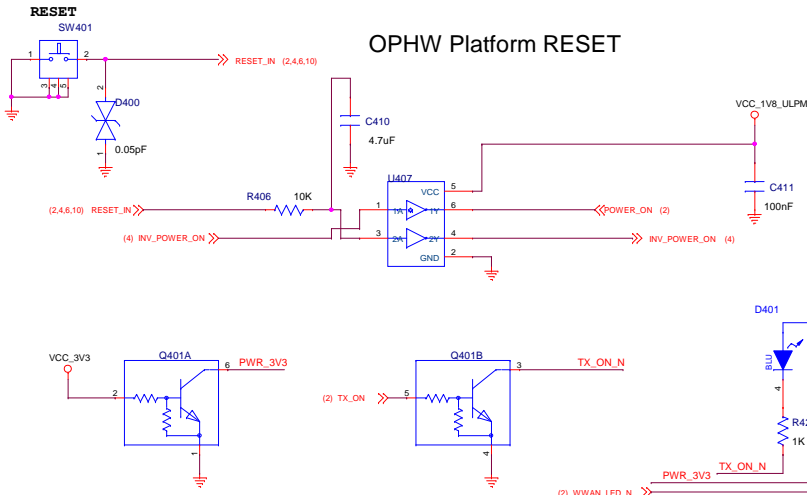

<p><Variant Name></p> <p>This document contains information which is proprietary and confidential to Sierra Wireless Inc. Disclosure to Persons other than the officers, employees, agents or subcontractors of the company or licensee of this document without the prior written permission of Sierra Wireless Inc. is strictly prohibited.</p> <p>Copyright (C) 2016</p>		<p>SITE</p> <p>CTO Office</p> <p>LEAD ENGINEER</p> <p>Ashish Syal</p>	
DOCUMENT NUMBER	2142586	REV SCH	See P1
PROJECT	mangOH Yellow	REV PCB	See P1
DATE	Friday, July 19, 2019	SIZE	C
		SHEET	4 OF 10

GAS, HUMIDITY AND PRESSURE SENSOR

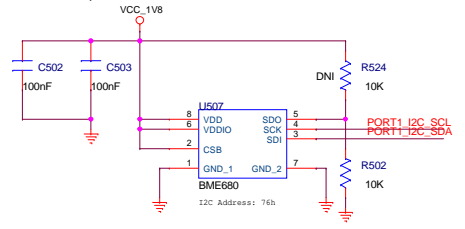

ACCELEROMETER AND GYROSCOPE

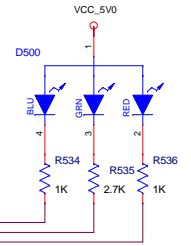
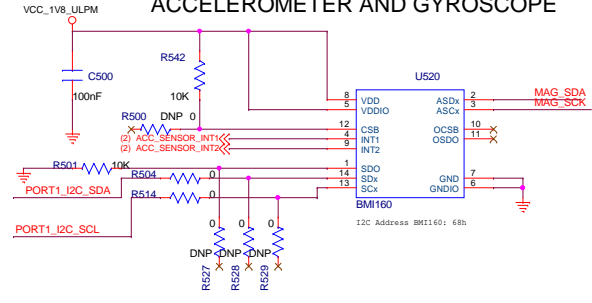

GEOMAGNETIC SENSOR

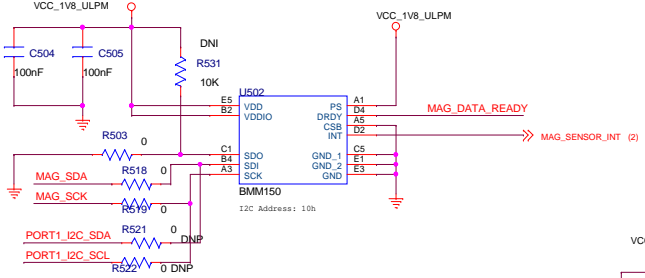

GPIO EXPANDER

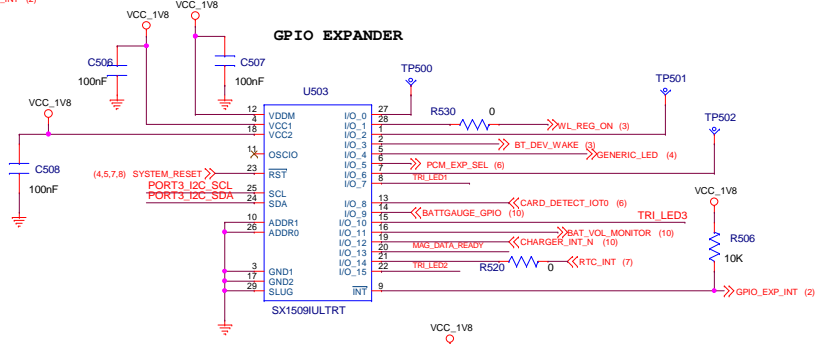

LIGHT SENSOR

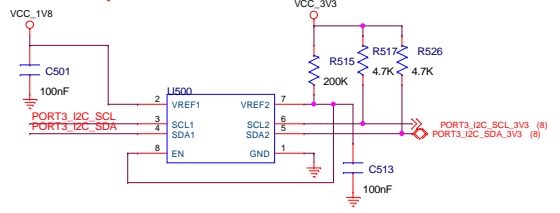
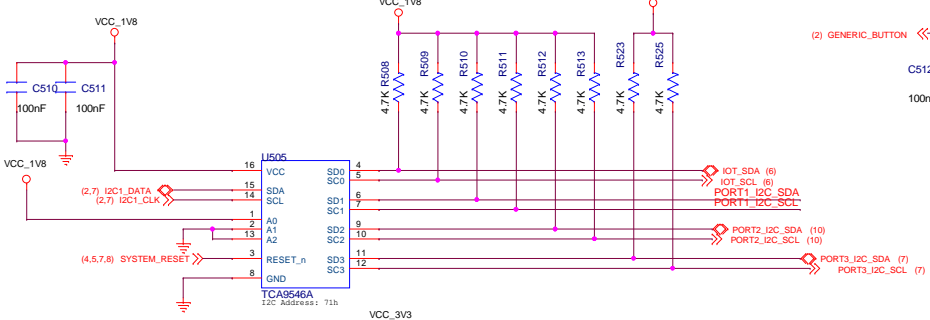
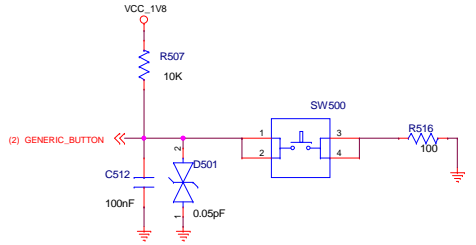
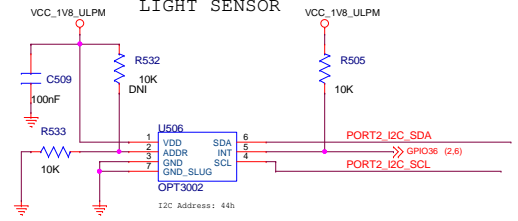

<Variant Name>
 This document contains information which is proprietary and confidential to Sierra Wireless Inc. Disclosure to Persons other than the officers, employees, agents or subcontractors of the company or licensee of this document without the prior written permission of Sierra Wireless Inc. is strictly prohibited.
 Copyright (C) 2016

		SITE	
		CTO Office	
DOCUMENT NUMBER 2142586		LEAD ENGINEER	
		Ashish Syal	
PROJECT		REV SCH	REV PCB
mangOH Yellow		See P1	See P1
DATE:		SIZE	
Friday, July 19, 2019		Custom	
		SHEET	OF
		5	10

SD CONNECTOR

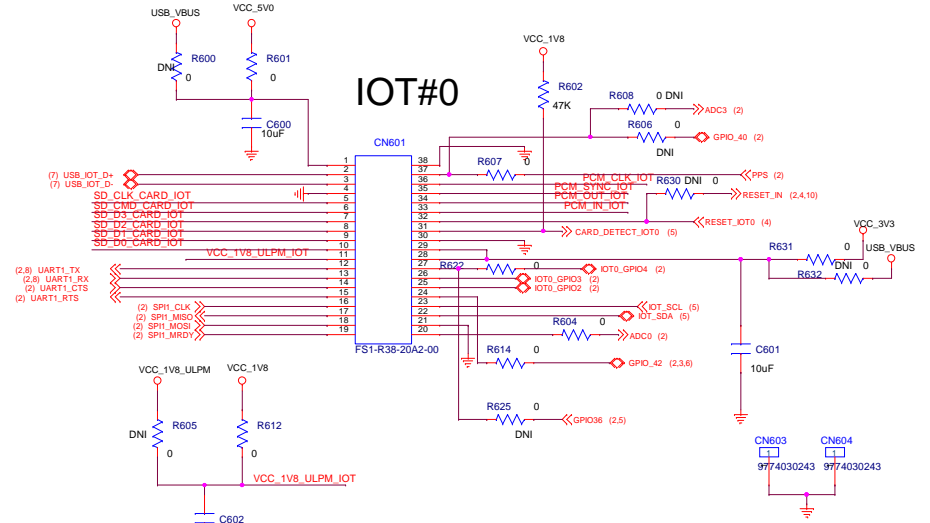
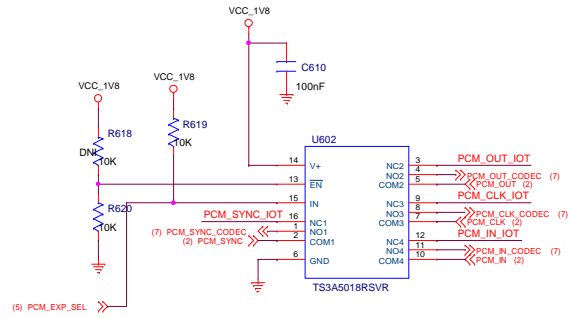

Mounting Holes for the IOT Connector

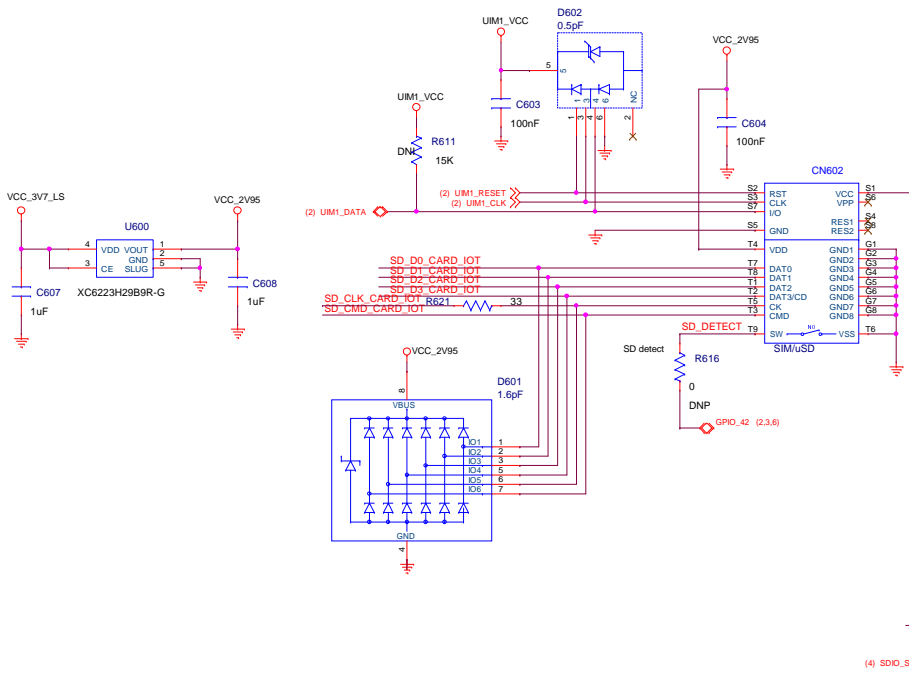
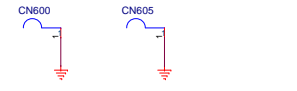

SDIO Expansion

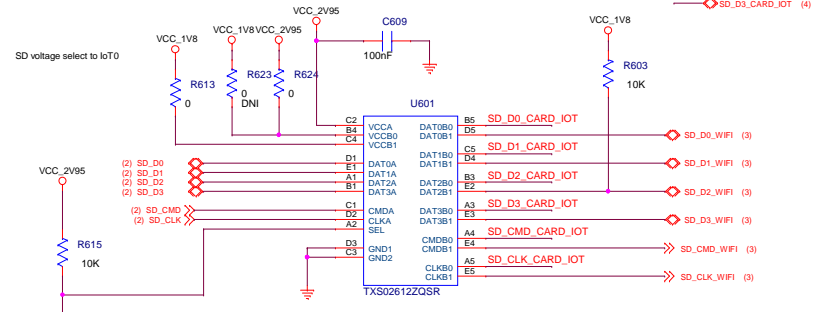

<Variant Name>

This document contains information which is proprietary and confidential to Sierra Wireless Inc. Disclosure to Persons other than the officers, employees, agents or subcontractors of the company or licensee of this document without the prior written permission of Sierra Wireless Inc. is strictly prohibited.
Copyright (C) 2016

		SITE	
		CTO Office	
DOCUMENT NUMBER 2142586		LEAD ENGINEER	
		Ashish Syal	
PROJECT	mangOH Yellow	REV SCH	REV PCB
DATE	Friday, July 19, 2019	See P1	See P1
		SIZE	C
		SHEET	6 OF 10

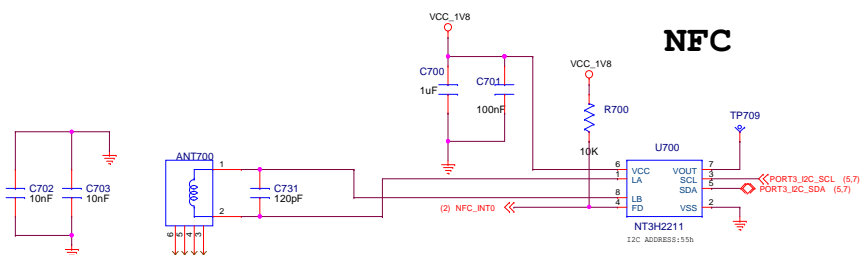

NOTE: REFER TO THE DATA SHEET AND MURATA RECOMMENDATIONS FOR CAPACITOR LAND, MOUNTING AND SLIT AREA

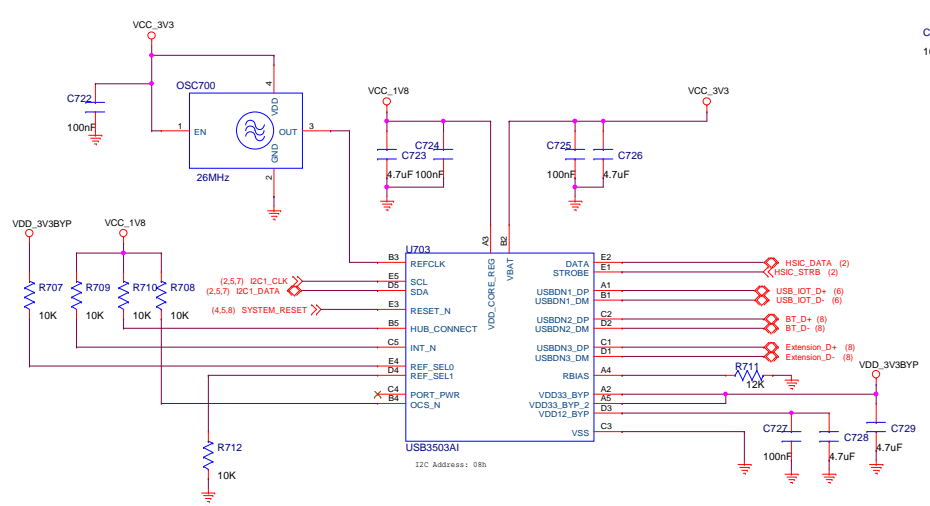
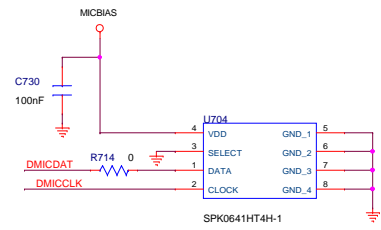
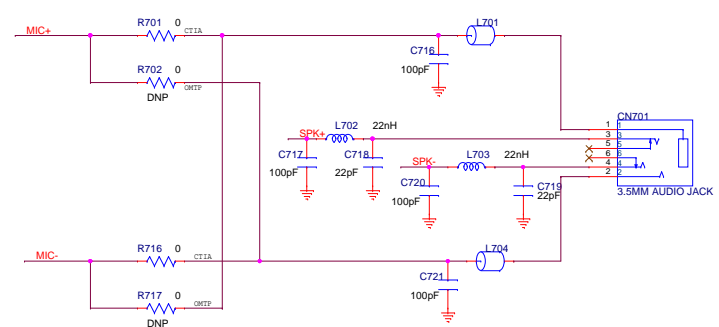
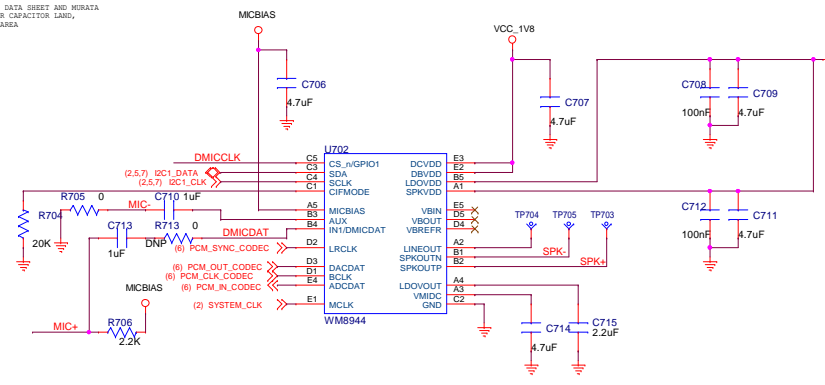
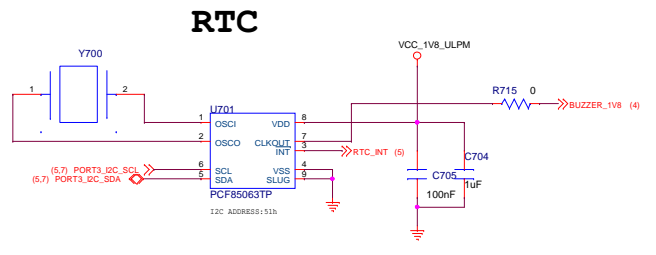

<Variant Name>
 This document contains information which is proprietary and confidential to Sierra Wireless Inc. Disclosure to Persons other than the officers, employees, agents or subcontractors of the company or licensee of this document without the prior written permission of Sierra Wireless Inc. is strictly prohibited.
 Copyright (C) 2016

		SITE	
		CTO Office	
DOCUMENT NUMBER 2142586		REV SCH	REV PCB
		See P1	See P1
PROJECT		SIZE	
mangOH Yellow		C	
DATE		SHEET	
Friday, July 19, 2019		7	OF 10

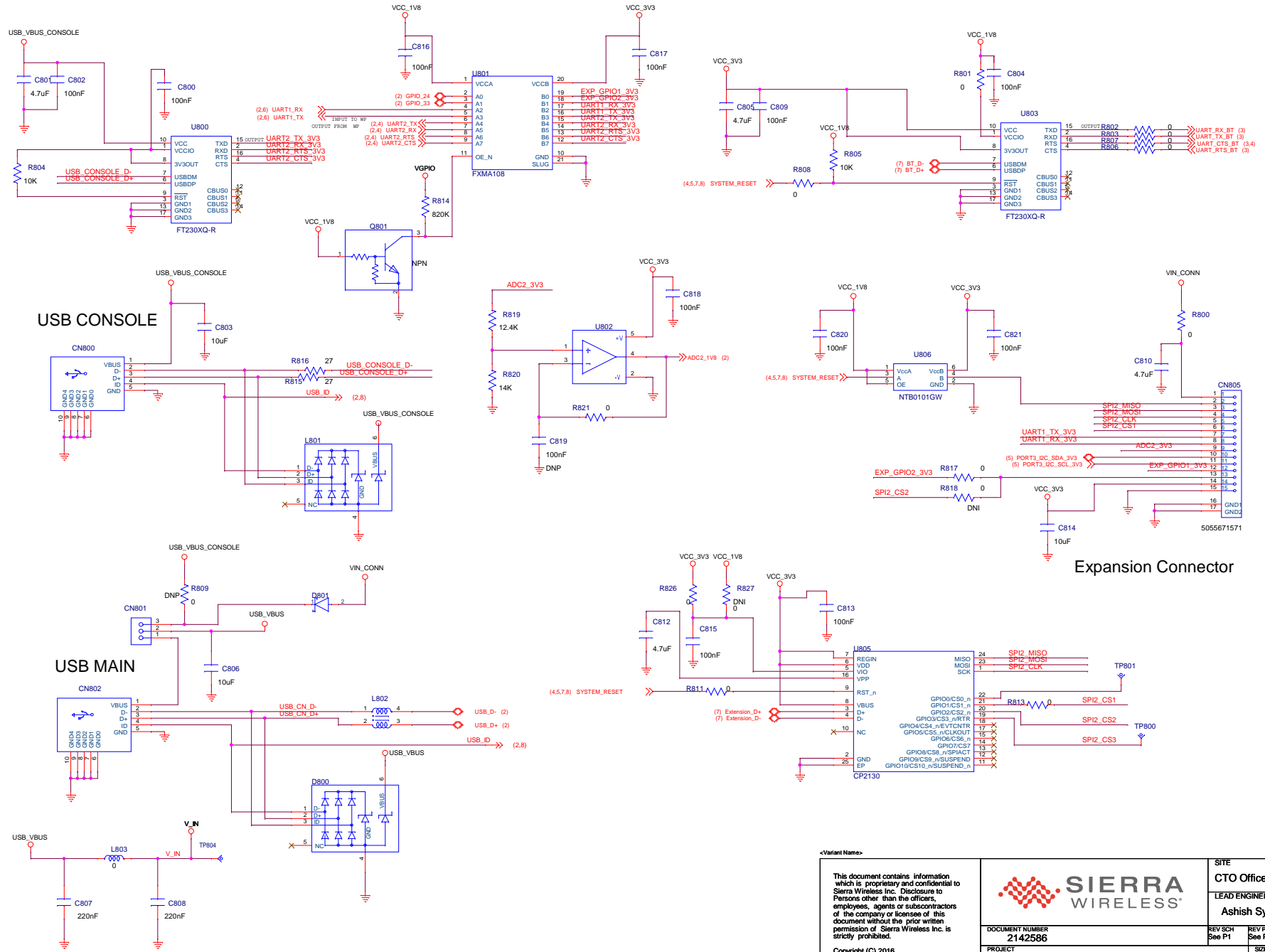

<p><Variant Name></p> <p>This document contains information which is proprietary and confidential to Sierra Wireless Inc. Disclosure to Persons other than the officers, employees, agents or subcontractors of the company or licensee of this document without the prior written permission of Sierra Wireless Inc. is strictly prohibited.</p> <p>Copyright (C) 2016</p>		<p>SIERRA WIRELESS</p>		<p>SITE</p> <p>CTO Office</p> <p>LEAD ENGINEER</p> <p>Ashish Syyal</p>	
<p>DOCUMENT NUMBER</p> <p>2142586</p>		<p>REV SCH</p> <p>See P1</p>		<p>REV PCB</p> <p>See P1</p>	
<p>PROJECT</p> <p>mangOH Yellow</p>		<p>DATE</p> <p>Friday, July 19, 2019</p>		<p>SIZE</p> <p>C</p>	
<p>SHEET 8 OF 10</p>				<p>5055671571</p>	

3V3 and 1V8 Buck

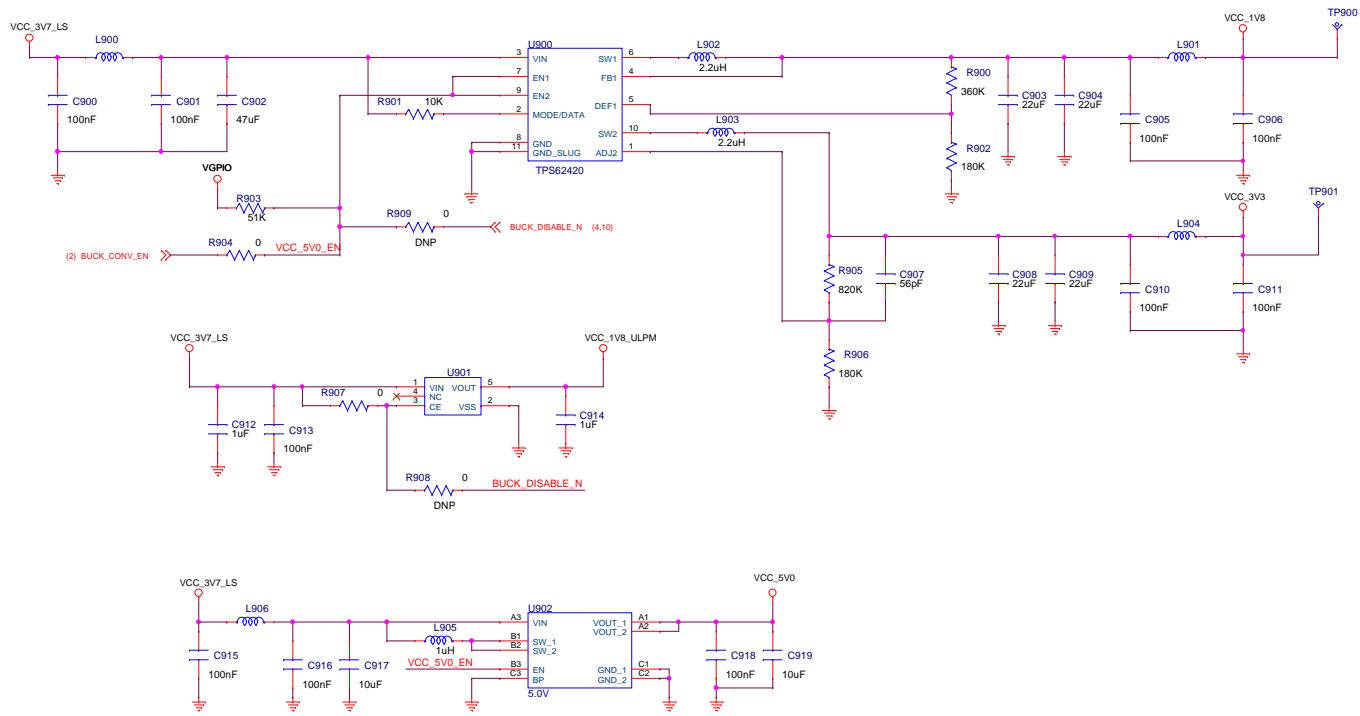

<Variant Name>

This document contains information which is proprietary and confidential to Sierra Wireless Inc. Disclosure to Persons other than the officers, employees, agents or subcontractors of the company or licensee of this document without the prior written permission of Sierra Wireless Inc. is strictly prohibited.
Copyright (C) 2016



SITE
CTO Office
LEAD ENGINEER
Ashish Syal

DOCUMENT NUMBER 2142586	REV SCH See P1	REV PCB See P1
PROJECT mangOH Yellow	SIZE C	
DATE Friday, July 19, 2019	SHEET 9 OF 10	

PSU Front End and 3.7V DC/DC converter

Note:
* For High Reliability systems use the WD feature of BO25601

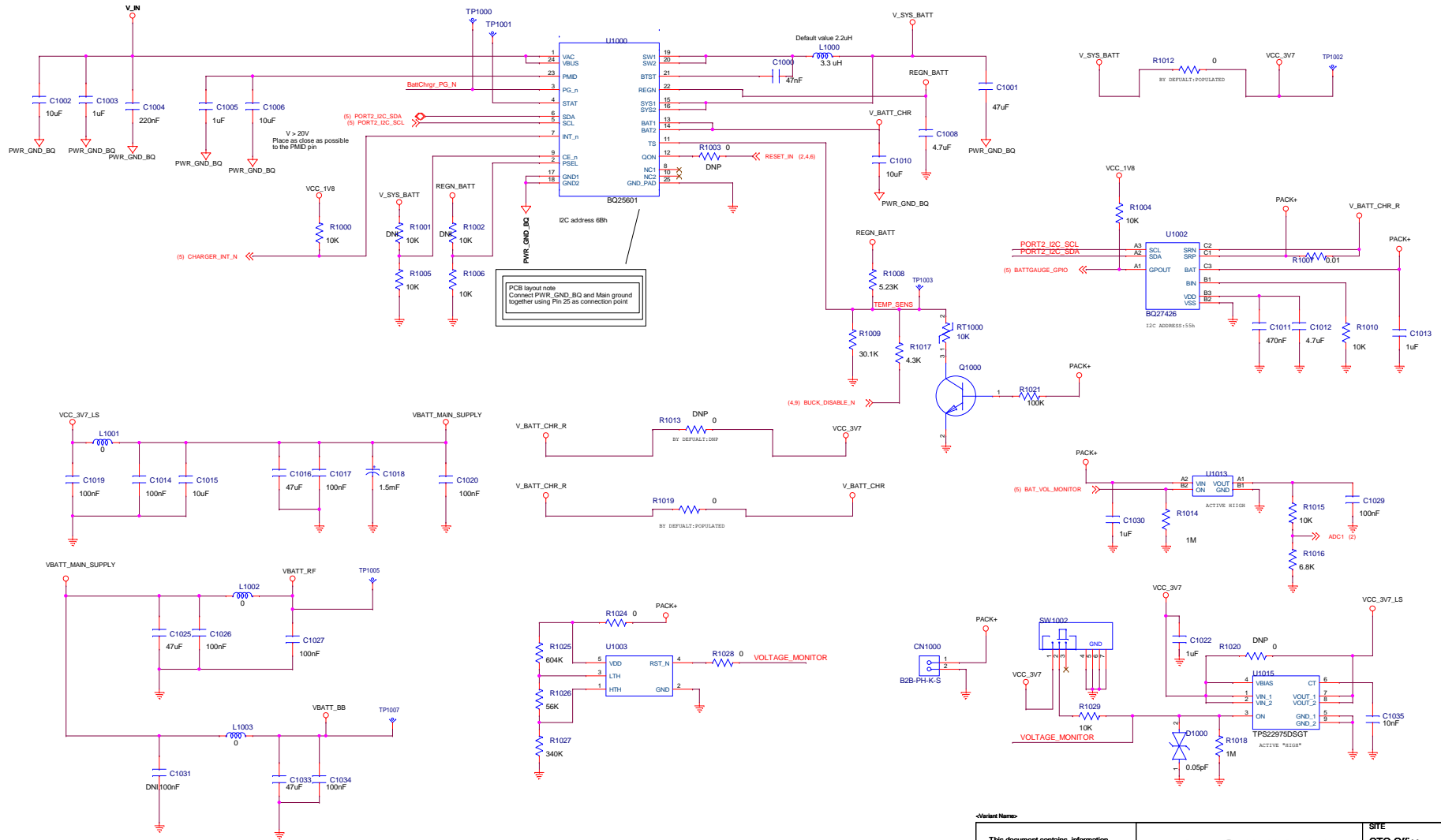

<p>Variant Name:</p> <p>This document contains information which is proprietary and confidential to Sierra Wireless Inc. Disclosure to Persons other than the officers, employees, agents or subcontractors of the company or licensee of this document without the prior written permission of Sierra Wireless Inc. is strictly prohibited.</p> <p>Copyright (C) 2016</p>		<p>SIERRA WIRELESS</p>		<p>SITE CTO Office</p>	
		<p>DOCUMENT NUMBER 2142586</p> <p>PROJECT mangOH Yellow</p> <p>DATE Friday, July 19, 2016</p>		<p>LEAD ENGINEER Ashish Syal</p> <p>REV SCH See P1</p> <p>REV PCB See P1</p> <p>SZ Custom</p>	
				<p>SHEET 10 OF 10</p>	