

# mangOH<sup>®</sup> Yellow

## Hardware Architecture Guide

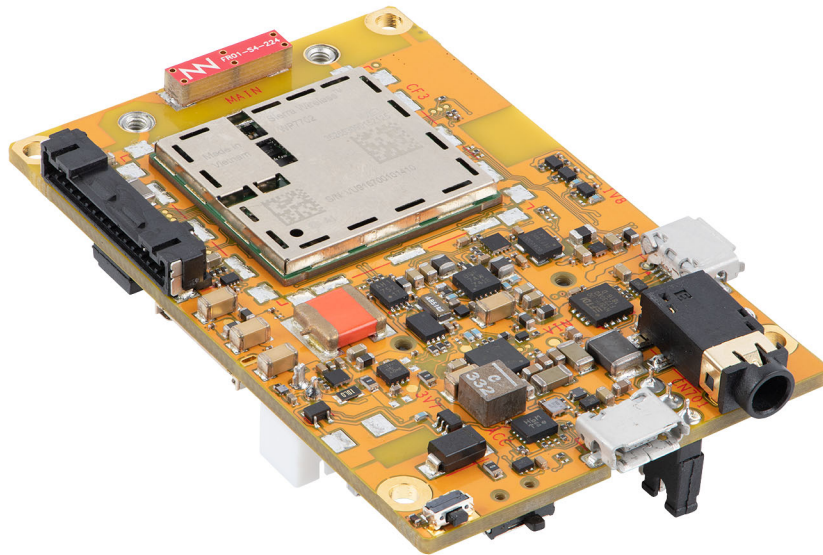

41113116  
Rev 3

## Important Notice

Due to the nature of wireless communications, transmission and reception of data can never be guaranteed. Data may be delayed, corrupted (i.e., have errors) or be totally lost. Although significant delays or losses of data are rare when wireless devices such as the Sierra Wireless modem are used in a normal manner with a well-constructed network, the Sierra Wireless modem should not be used in situations where failure to transmit or receive data could result in damage of any kind to the user or any other party, including but not limited to personal injury, death, or loss of property. Sierra Wireless accepts no responsibility for damages of any kind resulting from delays or errors in data transmitted or received using the Sierra Wireless modem, or for failure of the Sierra Wireless modem to transmit or receive such data.

## Safety and Hazards

Do not operate the Sierra Wireless modem in areas where blasting is in progress, where explosive atmospheres may be present, near medical equipment, near life support equipment, or any equipment which may be susceptible to any form of radio interference. In such areas, the Sierra Wireless modem **MUST BE POWERED OFF**. The Sierra Wireless modem can transmit signals that could interfere with this equipment.

Do not operate the Sierra Wireless modem in any aircraft, whether the aircraft is on the ground or in flight. In aircraft, the Sierra Wireless modem **MUST BE POWERED OFF**. When operating, the Sierra Wireless modem can transmit signals that could interfere with various onboard systems.

---

*Note: Some airlines may permit the use of cellular phones while the aircraft is on the ground and the door is open. Sierra Wireless modems may be used at this time.*

---

The driver or operator of any vehicle should not operate the Sierra Wireless modem while in control of a vehicle. Doing so will detract from the driver or operator's control and operation of that vehicle. In some states and provinces, operating such communications devices while in control of a vehicle is an offence.

## Limitation of Liability

The information in this manual is subject to change without notice and does not represent a commitment on the part of Sierra Wireless. SIERRA WIRELESS AND ITS AFFILIATES SPECIFICALLY DISCLAIM LIABILITY FOR ANY AND ALL DIRECT, INDIRECT, SPECIAL, GENERAL, INCIDENTAL, CONSEQUENTIAL, PUNITIVE OR EXEMPLARY DAMAGES INCLUDING, BUT NOT LIMITED TO, LOSS OF PROFITS OR REVENUE OR ANTICIPATED PROFITS OR REVENUE ARISING OUT OF THE USE OR INABILITY TO USE ANY SIERRA WIRELESS PRODUCT, EVEN IF SIERRA WIRELESS AND/OR ITS AFFILIATES HAS BEEN ADVISED OF THE POSSIBILITY OF SUCH DAMAGES OR THEY ARE FORESEEABLE OR FOR CLAIMS BY ANY THIRD PARTY.

Notwithstanding the foregoing, in no event shall Sierra Wireless and/or its affiliates aggregate liability arising under or in connection with the Sierra Wireless product, regardless of the number of events, occurrences, or claims giving rise to liability, be in excess of the price paid by the purchaser for the Sierra Wireless product.

## Patents

This document contains information which is proprietary to Sierra Wireless Inc. and is licensed pursuant to Creative Commons Attribution 4.0 International License.

## Document details

Title: mangOH Yellow Hardware Architecture Guide

Author: Sierra Wireless

Source: <https://mangoh.io>

## Copyright

© 2020 Sierra Wireless. Licensed under the Creative Commons Attribution 4.0 license, <http://creativecommons.org/licenses/by/4.0/>



## Disclaimer

Indicate any modifications made to the original document.

## Trademarks

mangOH® and the mangOH logo are trademarks of Sierra Wireless.

Other trademarks are the property of their respective owners.

## Revision History

Revision number	Release date	Changes
1	September 2019	Document created
1.01	September 2019	Document formatting adjustments
2	October 2019	Minor formatting corrections Corrected schematic component numbers where needed Added notes to not connect at same time IoT card and Expansion connector device Corrected SW403 Notes (Table 2-1) Added IoT Edge Connector pin drawing and schematic excerpt Updated GPIO Configuration Figure 2-9 Updated 2.4.16 Expansion connector description and table details Updated 2.4.20 UART1 Updated Expansion Connector Configuration Figure 2-26 Removed Regulatory Compliance chapter
3	June 2020	Changed mangOH™ to mangOH® Updated <a href="#">mangOH Yellow Hardware Architecture (Default)</a> figure Updated <a href="#">Wi-Fi+BT Module</a> (clarified 802.11n support)

# Contents

<b>Introduction</b> .....	<b>6</b>
<b>Hardware</b> .....	<b>7</b>
mangOH Yellow Hardware Overview .....	7
mangOH Yellow Hardware Architecture .....	10
Hardware Component Connections .....	11
MUXing .....	18
CF3 Module Signals .....	19
ADC .....	19
Audio (Analog and PCM) .....	19
CF3 GPIOs .....	20
GPIO Expander .....	22
HSIC (USB/Ethernet) .....	23
I2C1 .....	23
Light Sensor .....	24
Accelerator/Gyroscope .....	25
Gas/Humidity/Pressure/Temperature Sensor .....	25
Geomagnetic Sensor .....	26
RF .....	26
NFC .....	27
Battery .....	27
RTC .....	27
Buzzer .....	28
Expansion Connector .....	28
SDIO .....	29
SPI1 .....	30
UART0 .....	30
UART1 .....	30
UART2 .....	31
UIM .....	31
USB 2.0 .....	31

---

Wi-Fi+BT Module . . . . .	32
Wi-Fi RF . . . . .	33
Bluetooth RF . . . . .	33
IoT Connector Interfaces . . . . .	34
Expansion Connector Interfaces . . . . .	35
Reset Methods. . . . .	36
Power Management. . . . .	37
<b>Signal Name Variations . . . . .</b>	<b>39</b>

# 1: Introduction

The mangOH® Yellow open-source hardware development platform for CF3 modules incorporates several hardware interfaces and a standardized IoT Expansion Card slot for expanded functionality.

This hardware architecture guide describes the mangOH Yellow's architecture and provides details on how to develop applications for CF3 modules.

For the full mangOH Yellow documentation suite, refer to [mangoh.io/mangoh-yellow-resources](https://mangoh.io/mangoh-yellow-resources).

## 2: Hardware

This chapter describes the mangOH Yellow platform's hardware components and interfaces.

### 2.1 mangOH Yellow Hardware Overview

Figure 2-1 provides an overview of the mangOH Yellow's hardware components relative to the CF3 module, and Figure 2-2 on page 8 and Figure 2-3 on page 9 show their physical locations.

For additional details, see the following documents:

- Available at [mangoh.io/mangoh-yellow-resources](http://mangoh.io/mangoh-yellow-resources):
  - mangOH Yellow User Guide—Instructions on setting up the hardware components
- Available at [source.sierrawireless.com](http://source.sierrawireless.com):
  - Sierra Wireless CF3 module-specific Product Technical Specification documents
  - AirPrime Embedded Module Common Flexible Form Factor (CF3) Specification

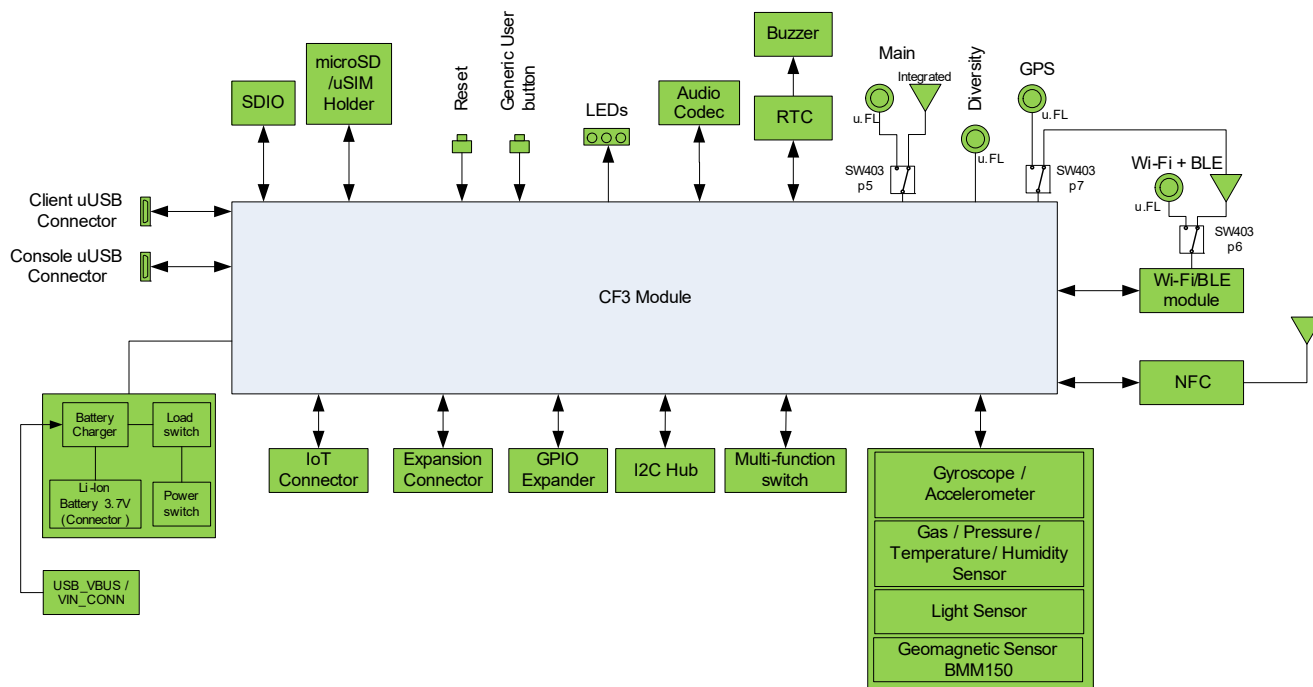

Figure 2-1: mangOH Yellow Hardware Components Overview

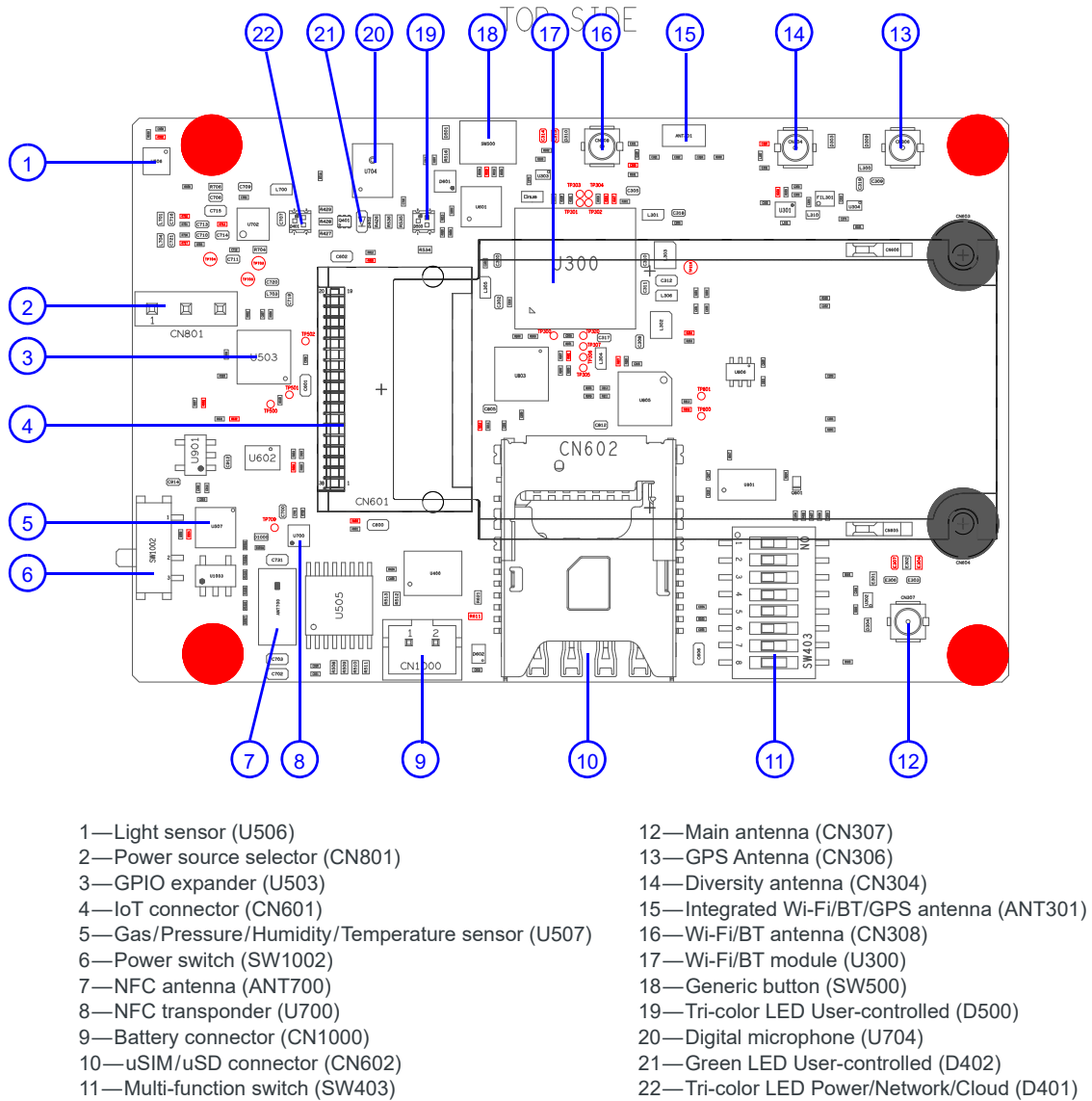
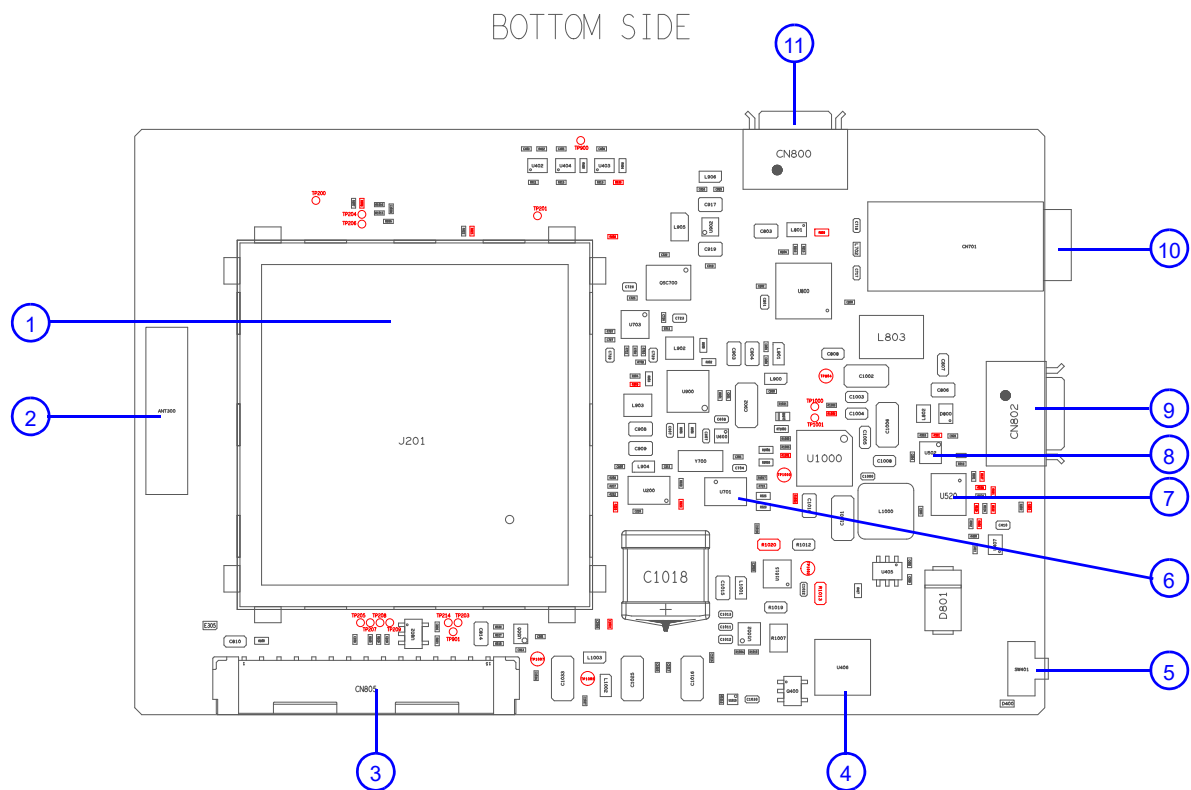

Figure 2-2: mangOH Yellow—Top Side Switches/Connectors

Note: For reference only. For latest schematic, visit [mangoh.io/mangoh-yellow-resources-hardware](http://mangoh.io/mangoh-yellow-resources-hardware).





- |                                    |                                  |
|------------------------------------|----------------------------------|
| 1—CF3 socket (J201)                | 7—Gyroscope/Accelerometer (U520) |
| 2—Integrated main antenna (ANT300) | 8—Geomagnetic sensor (U502)      |
| 3—Expansion connector (CN805)      | 9—Client USB connector (CN802)   |
| 4—Buzzer (U406)                    | 10—3.5 mm audio jack (CN701)     |
| 5—Reset button (SW401)             | 11—Console USB connector (CN800) |
| 6—RTC (U701)                       |                                  |

Figure 2-3: mangOH Yellow—Bottom Side Switches/Connectors

Note: For reference only. For latest schematics, visit [mangoh.io/mangoh-yellow-resources-hardware](http://mangoh.io/mangoh-yellow-resources-hardware).

## 2.2 mangOH Yellow Hardware Architecture

The mangOH Yellow platform provides several hardware components (as shown in [Figure 2-2 on page 8](#) and [Figure 2-3 on page 9](#)), including:

- CF3 module socket
- Wi-Fi+BT module (USI WM-BN-CYW-48)
- Pluggable IoT Connector (socket for IoT Expansion Card)
- Several I/O connectors (SIM, SD, Audio, USB, etc.)
- Expansion Connector

[Figure 2-4](#) illustrates the mangOH Yellow’s default hardware architecture (connectors and signals). The following sections describe these features in greater detail:

- [Hardware Component Connections on page 11](#)—mangOH Yellow hardware components overview.
- [CF3 Module Signals on page 19](#)—CF3 module connections to hardware components.
- [Wi-Fi+BT Module on page 32](#)—Wi-Fi+BT module connections to hardware components.
- [IoT Connector Interfaces on page 34](#)—IoT Expansion Card signal connections to the hardware components.
- [Expansion Connector Interfaces on page 35](#)—Expansion connector signal connections to the hardware components.

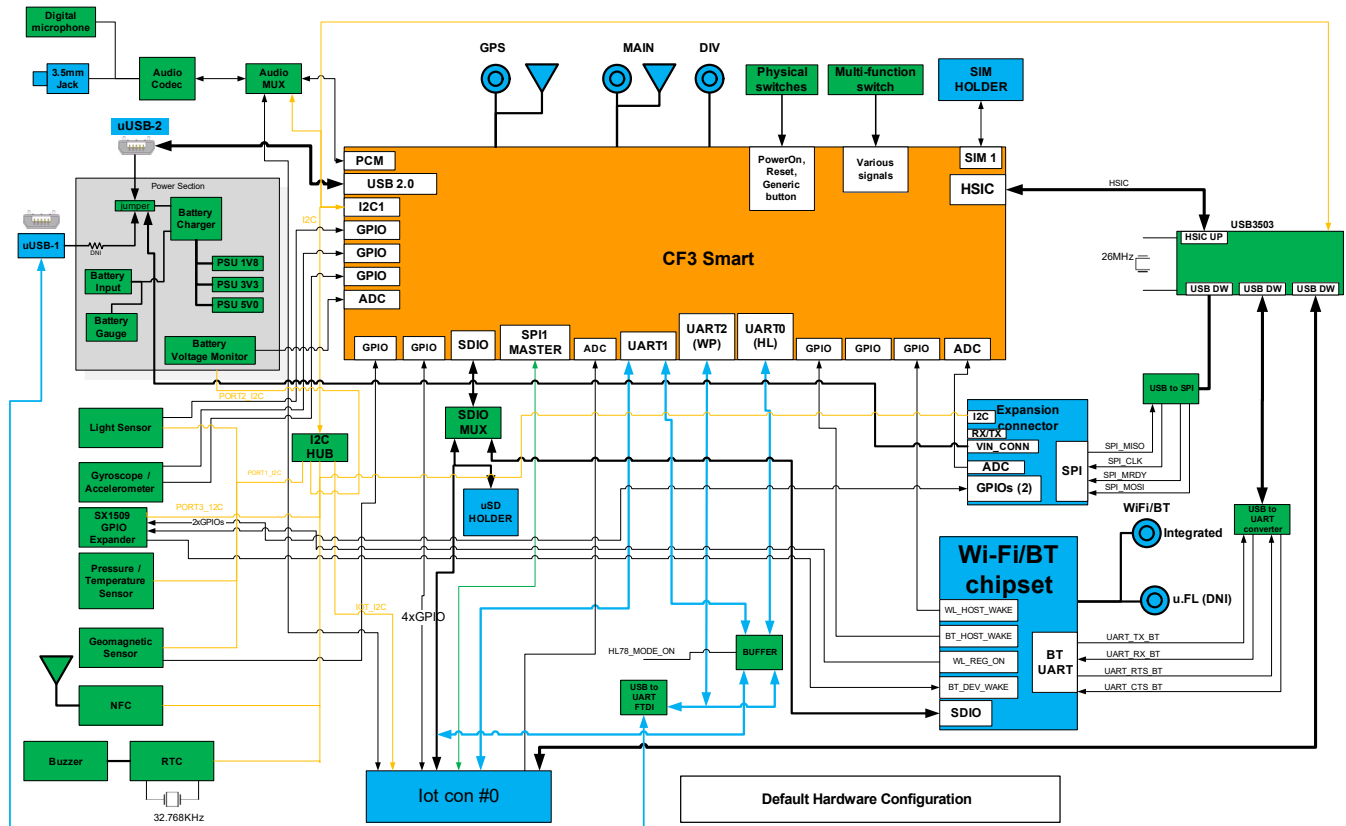

Figure 2-4: mangOH Yellow Hardware Architecture (Default)

## 2.2.1 Hardware Component Connections

Key mangOH Yellow hardware components and their connections to the CF3 module and/or Wi-Fi+BT module are listed in [Table 2-1 on page 11](#).

The mangOH Yellow's default configuration enables specific interfaces when the platform boots. For interface details, see:

- [MUXing on page 18](#)
- [CF3 Module Signals on page 19](#)
- [Wi-Fi+BT Module on page 32](#)
- [IoT Connector Interfaces on page 34](#)
- [Expansion Connector Interfaces on page 35](#)
- [Reset Methods on page 36](#)
- [Power Management on page 37](#)

**Important:** Do not use the UART connections on both an IoT card and a device via the expansion connector to the mangOH Yellow at the same time.

**Table 2-1: mangOH Yellow Hardware Components**

Type and Designator <sup>a</sup>	Description	Signals / Pins	Notes
Modules/Processors/etc.			
CF3 module (J201)	Socket for supported CF3 module (e.g. WP76, HL78, etc.)	For details, see <a href="#">CF3 Module Signals on page 19</a> .	
IOT0 (CN601)	IoT Expansion Card	Connections to multiple CF3 module interfaces.	For details, see <a href="#">IoT Expansion Card on page 16</a> .
Wi-Fi+BT module (U300)	USI Wi-Fi+BT module	For details, see <a href="#">Wi-Fi+BT Module on page 32</a> .	
NFC RFID Transponder (U700)	Integrated NT3H2211 RFID transponder	<ul style="list-style-type: none"> <li>• NFC_INT0 (to CF3)</li> <li>• I2C (via I2C hub to CF3)</li> </ul>	For details, see <a href="#">NFC on page 27</a> .
Card slots			
micro-SIM / micro-SD combination connector tray (CN602)	Micro-SIM holder (bottom socket)	CF3 UIM1 (Pins: 26–29)	Purpose: UIM used to establish mobile network connection. For details, see <a href="#">UIM on page 31</a> .
	Micro-SIM/ microSD holder (top socket)	CF3 SDIO (Pins: 161–166)	Purpose: Provide access to microSD card. For details, see: <ul style="list-style-type: none"> <li>• <a href="#">SDIO on page 29</a></li> <li>• <a href="#">MUXing on page 18</a></li> </ul>

**Table 2-1: mangOH Yellow Hardware Components (Continued)**

Type and Designator <sup>a</sup>	Description	Signals / Pins	Notes
USB-type connectors			
micro-USB (CN802)	Client USB micro-USB connector	<ul style="list-style-type: none"> <li>USB (Pins: 12, 13, 16)</li> <li>Power (if selected)</li> </ul>	Purpose: <ul style="list-style-type: none"> <li>Direct connection to CF3 USB</li> <li>Power supply—Provides power when selected by the Power Supply Selection Jumper (CN801). See mangOH Yellow User Guide for details.</li> </ul> For details, see <a href="#">USB 2.0 on page 31</a> .
micro-USB (CN800)	Console USB micro-USB connector	<ul style="list-style-type: none"> <li>UART2 (Pins: 96–99)</li> <li>Power (if selected)</li> </ul>	<ul style="list-style-type: none"> <li>Purpose: Console— Connects to CF3 module console</li> <li>Power supply—Provides power when selected by the Power Supply Selection Jumper (CN801) if hardware change (register R809 pop/R800 depop) has been performed. See mangOH Yellow User Guide for details.</li> </ul> For details, see <a href="#">UART2 on page 31</a> .
Antennas			
RF Antennas Main (CN307) GNSS (CN306) Diversity (CN304)	u.FL connectors	CF3 RF (Pins: 49 (Main), 38 (GNSS), 31 (Diversity))	For details, see <a href="#">RF on page 26</a> .  <i>Note: Integrated antenna is for Main only. ANT301 can be used for GNSS. No integrated antenna available for diversity.</i>
Integrated Main Antenna (ANT300)	Integrated		
Wi-Fi/BT Antenna (CN308)	u.FL connector	Wi-Fi+BT module RF	For details, see <a href="#">Wi-Fi+BT Module on page 32</a> .
Wi-Fi/BT / GPS Integrated Antenna (ANT301)	Integrated	<ul style="list-style-type: none"> <li>Wi-Fi+BT module RF</li> <li>CF3 Pin 38 (GNSS)</li> </ul>	
NFC Integrated Antenna (ANT700)	Integrated	Connects to NFC RFID Transponder (U700) pins 1 (LA) and 8 (LB)	For details, see <a href="#">NFC on page 27</a> .
Audio connectors			
Audio (CN701)	3.5 mm connector	CF3 digital audio signals (Pins: 30–33)	Purpose: Provide audio capability to CF3 module. Default microphone: Integrated digital microphone. Resistor pop/depop required to configure device to use 3.5 mm connector. For details, see: <ul style="list-style-type: none"> <li><a href="#">Audio (Analog and PCM) on page 19</a></li> <li><a href="#">MUXing on page 18</a></li> </ul>
Microphone (U704)	Integrated SPK0838HT4H-B digital microphone		

**Table 2-1: mangOH Yellow Hardware Components (Continued)**

Type and Designator <sup>a</sup>	Description	Signals / Pins	Notes
Sensors			
Gyroscope/ Accelerometer (U520)	Integrated BMI160 inertial measurement module	I2C Expander signals	Purpose: Provides rotational, linear motion, and gravitational force measurements for use in (for example) gaming, mapping, navigation, drones, and optical image stabilization applications. For details, see <a href="#">Accelerator/Gyroscope on page 25</a> and <a href="#">I2C1 on page 23</a> .
Gas, Pressure, Humidity, Temperature sensor (U507)	Integrated BME680 barometric pressure sensor		Purpose: Provides gas (volatile organic compounds), barometric pressure, altitude, and temperature measurements for use in (for example) GPS navigation, indoor/outdoor navigation, air quality measurement, and weather forecasting applications. For details, see <a href="#">Gas/Humidity/Pressure/Temperature Sensor on page 25</a> and <a href="#">I2C1 on page 23</a> .
Geomagnetic sensor (U502)	Integrated BMM150 3-axis digital geomagnetic sensor		Purpose: Provides geomagnetic measurements that can be combined with the gyroscope/accelerometer readings measurements for the 9-axis inertial sensing needed for use in (for example) GPS navigation, augmented reality, drones, and gaming applications. For details, see <a href="#">Geomagnetic Sensor on page 26</a> and <a href="#">I2C1 on page 23</a> .
Light sensor (U506)	Integrated OPT3002DNPT ambient light sensor		Purpose: Provide ambient light measurements for use in (for example) brightness control systems. For details, see <a href="#">Light Sensor on page 24</a> and <a href="#">I2C1 on page 23</a> .
Other ICs and components			
GPIO expander (U503)	Integrated SX1509 expander	CF3 I2C1 interface	Purpose: Provides additional GPIOs. For details, see: <ul style="list-style-type: none"> <li>• <a href="#">GPIO Expander on page 22</a></li> <li>• <a href="#">I2C1 on page 23</a></li> </ul>
Real-time clock (U701)	Integrated PCF85063TP CMOS Real- time clock/ calendar	CF3 I2C1 interface	Purpose: Low power consumption RTC for use in (for example) mobile equipment and battery-operated device applications. For details, see <a href="#">RTC on page 27</a> and <a href="#">I2C1 on page 23</a> .
Buzzer (U406)	Integrated CMT- 4023S-SMT magnetic buzzer transducer	<ul style="list-style-type: none"> <li>• BUZZER_1V8, provided by RTC (U701)</li> </ul>	For details, see <a href="#">Buzzer on page 28</a> .
Expansion Connector (CN805)	15-pin (male) SMT connector	Connections to multiple CF3 module interfaces.	Purpose: Allows connection of an external device to the mangOH Yellow. Power can be supplied from the device to the Yellow, or from the Yellow to the device. For details, see <a href="#">Expansion Connector Interfaces on page 35</a> and <a href="#">Expansion Connector on page 28</a> .

**Table 2-1: mangOH Yellow Hardware Components (Continued)**

Type and Designator <sup>a</sup>	Description	Signals / Pins	Notes
LEDs			
Tri-color PWR/ Network/Cloud LED (D401)	Tri-color (RGB) LED	Hardware-controlled Visible LED Behavior: <ul style="list-style-type: none"> <li>• Green—Power is on</li> <li>• Yellow—Power on + Cellular radio on</li> <li>• White—Power on + Cellular radio is transmitting/receiving</li> </ul> <i>Note: D401 only appears as Green, Yellow (Green+Red), or White (Green+Red+Blue).</i>	
		Green—VCC_3V3	Purpose: Indicates device is powered on.
		Red—CF3 WWAN_LED_N	Purpose: Indicates cellular radio is on.
		Blue—CF3 TX_ON	Purpose: Indicates CF3 module is transmitting/receiving.
Generic green LED (D402)	Green LED	(GPIO expander) GENERIC_LED	Software-controlled Purpose: User-defined (programmable)
Generic tri-color LED (D500)	Tri-color (RGB) LED	(GPIO expander) Blue—TRI_LED1 Green—TRI_LED2 Red—TRI_LED3	Software-controlled Purpose: User-defined (programmable) <i>Note: All color combinations can be used. (e.g. B, G, R, BG, BR, GR, BGR)</i>

**Table 2-1: mangOH Yellow Hardware Components (Continued)**

Type and Designator <sup>a</sup>	Description	Signals / Pins	Notes
Platform controls			
Multi-function switch (SW403 )	Module signals control	Eight dipswitches:	
		1. HL78_MODE_ON	Module type installed: <ul style="list-style-type: none"> <li>ON—HL78 module installed. (Note: HL78 UART0 signals are carried on the CF3 socket's UIM2 pins.)</li> <li>OFF—WP module installed</li> </ul>
		2. TP1_BOOT	CF3 module's TP1 (boot) signal <ul style="list-style-type: none"> <li>ON—Stop boot process at primary bootloader and enter recovery programming mode</li> <li>OFF—Boot normally</li> </ul>
		3. BUCK_DISABLE_N	Buck converter state, controls which components receive power <ul style="list-style-type: none"> <li>ON—Converter is off. Only CF3 module receives power.</li> <li>OFF—Converter is on. All components receive power.</li> </ul>
		4. W_DISABLE_N	Radio state <ul style="list-style-type: none"> <li>ON—Disable</li> <li>OFF—Enable</li> </ul>
		5. CELL_ANT_CNTR	Main antenna to use <ul style="list-style-type: none"> <li>ON—External (use Main u.FL connector)</li> <li>OFF—Integrated</li> </ul>
		6. WIFI_ANT_CNTR	Wi-Fi antenna to use <ul style="list-style-type: none"> <li>ON—External (use Wi-Fi u.FL connector)</li> <li>OFF—Integrated</li> </ul>
		7. GPS_ANT_CNTR	GPS antenna to use <ul style="list-style-type: none"> <li>ON—External (use GPS u.FL connector)</li> <li>OFF—Integrated</li> </ul>
		8. SDIO_SEL2	SD interface source <ul style="list-style-type: none"> <li>ON—microSD card/loT card</li> <li>OFF—Wi-Fi module</li> </ul>
Power Source Selector (CN801)	3-pin vertical post-terminal strip		Power source selector <ul style="list-style-type: none"> <li>Pins 1/2—Client USB</li> <li>Pins 2/3—Expansion connector (default configuration); Console USB (alternate configuration via resistor R809/R800 pop/depop)</li> </ul>
Reset Button (SW401)	Reset pushbutton	RESET_IN	Purpose:Hardware reset
Generic Button (SW500)	User-defined pushbutton	GENERIC_BUTTON (CF3 GPIO25)	Purpose: User-defined button

**Table 2-1: mangOH Yellow Hardware Components (Continued)**

Type and Designator <sup>a</sup>	Description	Signals / Pins	Notes
Power Switch (SW1002)	Toggle switch		Purpose: Controls board power (ON/OFF), regardless of power source.
Battery Connector (CN1000)	Battery connector	PACK+	Purpose: External battery power supply. For behavior details, see <a href="#">Battery on page 27</a> .

a. Board designators (e.g. CN311, SW401, etc.) are for reference against the published mangOH Yellow schematic. For component locations on the board, see [Figure 2-2 on page 8](#) and [Figure 2-3 on page 9](#).

### 2.2.1.1 IoT Expansion Card

mangOH Yellow includes one IoT connector (CN601) that connects an IoT Expansion Card to the CF3 module’s signals as detailed in [Table 2-2](#).

This slot provides full support for the IoT Expansion Card specification. ([Figure 2-6](#) and [Figure 2-6](#) illustrate the pin positions and configuration.)

By default, specific signals are enabled when the mangOH Yellow boots. For additional information, including default configuration and how to temporarily change it, see [IoT Connector Interfaces on page 34](#).

For detailed specifications, see the Project mangOH IoT Expansion Card Design Specification available at [mangoh.io/iot-card-resources-documentation](http://mangoh.io/iot-card-resources-documentation).

**Important:** Do not use the UART connections on both an IoT card and a device via the expansion connector ([Expansion Connector on page 28](#)) to the mangOH Yellow at the same time.

**Table 2-2: IoT Expansion Card Signal Connections**

IoT Signals	CF3/Other Signal(s)		Notes
	Signal	Mux	
USB (Pins 2, 3)	HSIC (Pins 14, 15)	No	Purpose: Data transfer; application control For details, see <a href="#">HSIC (USB/Ethernet) on page 23</a> .
SDIO (Pins 5–10)	SDIO (Pins 161–166)	Yes	Purpose: Data transfer For details, see: <ul style="list-style-type: none"> <li>• <a href="#">SDIO on page 29</a></li> <li>• <a href="#">MUXing on page 18</a></li> </ul>
UART (Pins 12–15)	UART1 (Pins 3–6)	No	Purpose: Data transfer For details, see <a href="#">UART1 on page 30</a> .
SPI (Pins 16–19)	SPI1 (Pins 51–54)	No	Purpose: Data transfer For details, see <a href="#">SPI1 on page 30</a> .
ADC (Pin 20)	ADC0 (Pin 25)	No	Purpose: General purpose ADC output to host application (e.g. indicate when a sensor has triggered) For details, see <a href="#">ADC on page 19</a> .



**Table 2-2: IoT Expansion Card Signal Connections (Continued)**

IoT Signals	CF3/Other Signal(s)		Notes
	Signal	Mux	
I2C (Pins 22–23)	I2C1 (Pins 1, 66)	Hub	Purpose: Data transfer (standard mode). Higher speeds possible if supported by host application. For details, see <a href="#">I2C1 on page 23</a> .
GPIO_1 (Pin 24)	GPIO42 (Pin 109)	No	Purpose: Customer-defined data communication For details, see <a href="#">CF3 GPIOs on page 20</a> .
GPIO_2 (Pin 25)	SPI1_SRDY (Pin 44)	No	
GPIO_3 (Pin 26)	GPIO7 (Pin 40)	No	
GPIO_4 (Pin 27)	GPIO8 (Pin 41)	No	
n_CARD_DETECT (Pin 31)	I2C via GPIO Expander I/O_8		Purpose: Indicates an IoT card is inserted in the IoT expansion connector (CN601). For details, see <a href="#">GPIO Expander on page 22</a> .
n_RESET (Pin 32)	RESET_IOT0 (via Reset circuitry)	No	Purpose: Reset the IoT card. For details, see <a href="#">Reset Methods on page 36</a> .
PCM (Pins 33–36)	PCM (Pins 33–36)	No	Purpose: Digital audio interface For details, see <a href="#">Audio (Analog and PCM) on page 19</a> .
PPS (Pin 37)	DR_SYNC (Pin 42)	No	Purpose: Clock signal used to manage timing for sensor nodes (or other devices) that are connected to the expansion card. The signal is a stratum 1 clock input from the host application, where the host application operates as a stratum 1 time source connected to GPS (a stratum 0 source).
Power (Pins 1 (5V), 11 (1.8V), 28/29 (3.3V)) Ground (4, 21, 30, 38)	Power	n/a	Default configuration—Receives three power inputs: <ul style="list-style-type: none"> <li>• 5.0V @ 500 mA</li> <li>• 3.3V @ 1 A</li> <li>• 1.8V @ 200 mA</li> </ul> For details, see <a href="#">Power Management on page 37</a> .
Alternate signal functions (require hardware reconfiguration)			
GPIO_4 (Pin 27)	GPIO36 (from light sensor)	No	Input from light sensor
n_RESET (Pin 32)	RESET_N (Pin 11)	No	Purpose: Reset the CF3 module from the IoT card.
PPS (Pin 37)	GPIO40 (Pin 94)	No	Purpose: Customer-defined data communication For details, see <a href="#">CF3 GPIOs on page 20</a> .
PPS (Pin 37)	ADC3 (Pin 108)	No	Purpose: General purpose ADC output to host application (e.g. indicate when a sensor has triggered) For details, see <a href="#">ADC on page 19</a> .



## 2.4 CF3 Module Signals

This section describes how CF3 module signals connect to the platform hardware components (described in [Hardware Component Connections on page 11](#)).

**Important:** CF3 module signal availability depends on the module type—some modules may not implement certain Extension signals from the CF3 specification.

### 2.4.1 ADC

The mangOH Yellow supports four CF3 module ADC (Analog to Digital converter) signal sources (ADC0-ADC3).

The ADC signals connect to the following sources, as shown in [Figure 2-7](#):

- ADC0—IoT Connector 0 (CN1000, slot IOT0), pin 20
- ADC1—Battery Voltage Monitor (BAT\_VOL\_MONITOR)
- ADC2—Expansion connector (CN805), pin 9
- ADC3—IoT Connector 0 (CN1000, slot IOT0), pin 37 (Hardware modification required)

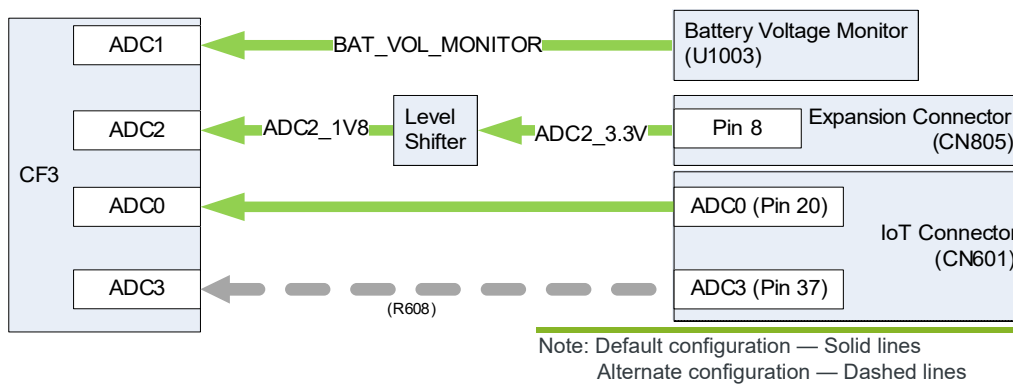

Figure 2-7: ADC Configuration

### 2.4.2 Audio (Analog and PCM)

The mangOH Yellow supports the CF3 module PCM (digital) audio signals. The signals connect via a Mux (analog switch) to the following sources, as shown in [Figure 2-8](#):

- 3.5 mm analog audio jack (Default configuration)
- IoT connector (Alternate configuration)

The audio interface configuration can be modified as described in [Table 2-3](#).

**Table 2-3: Audio Interface Configuration Changes**

Change type	Change effect	Method	Change duration
Software	Switch audio I/O from audio codec to IoT connector (or switch back)	Use the control signal (PCM_EXP_SEL) to switch between the audio I/O sources.	Until device reboots (non-persistent)
Hardware	Select microphone type (digital/analog)	Populate/depopulate resistors: <ul style="list-style-type: none"> <li>Select 3.5mm jack or digital microphone:</li> <li>• R713—(Default) Enables Digital microphone</li> <li>• R714—Enables 3.5 mm jack</li> </ul>	Selected configuration used every time device boots up.

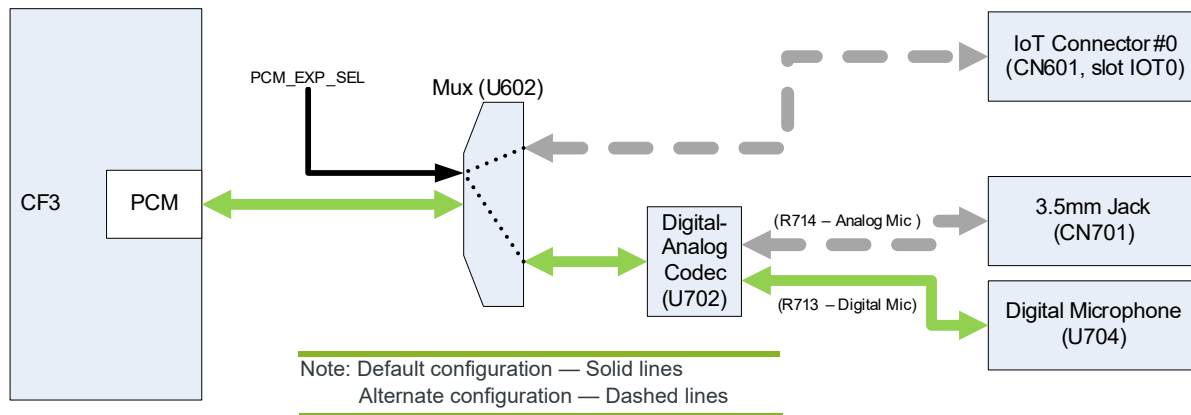

Figure 2-8: Audio Configuration

### 2.4.3 CF3 GPIOs

The mangOH Yellow supports several CF3 module GPIOs, as shown in [Figure 2-9](#).

*Note: The mangOH Yellow uses a GPIO expander for additional I/O functions. See [GPIO Expander on page 22](#).*

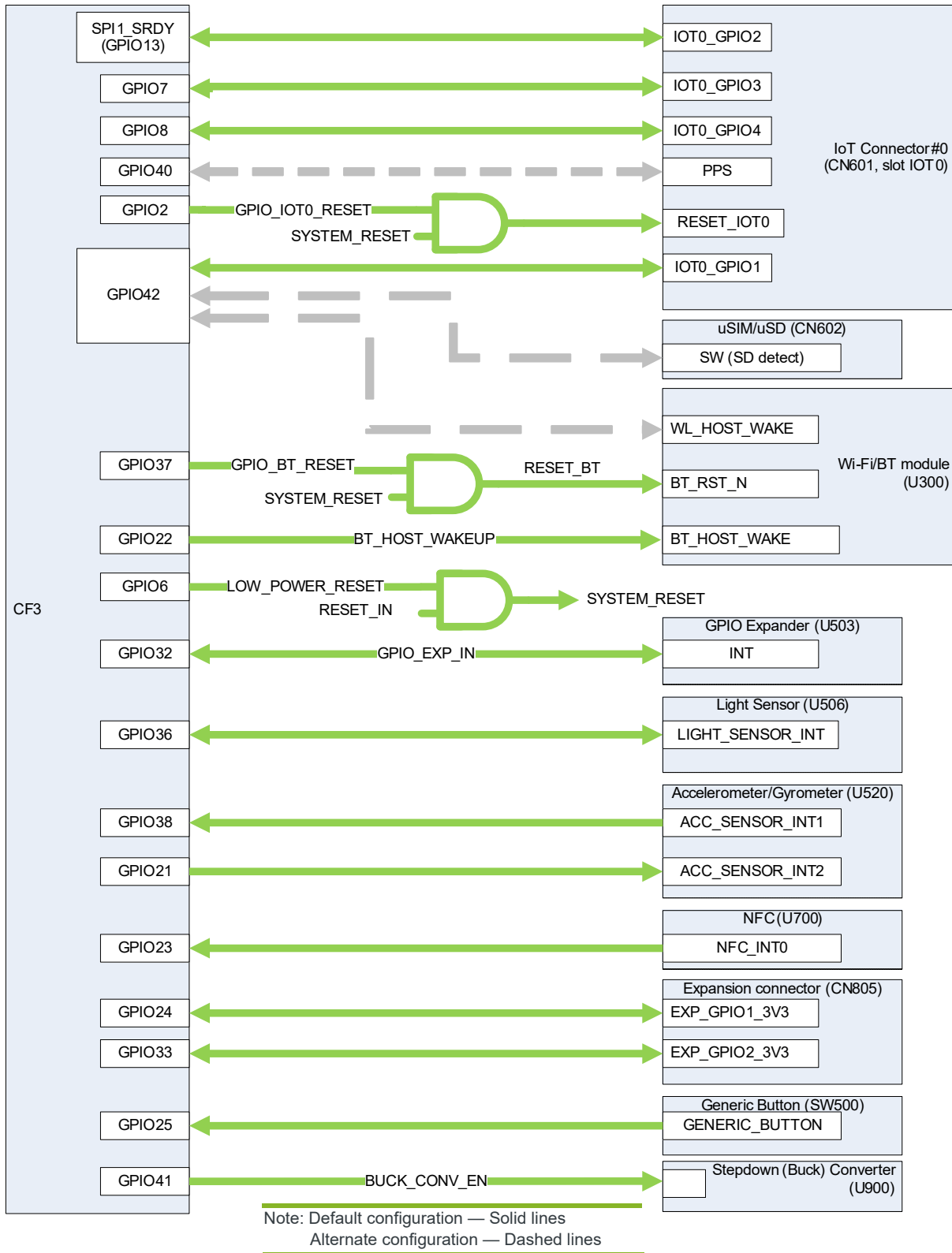

Figure 2-9: GPIO Configuration

## 2.4.4 GPIO Expander

The mangOH Yellow includes one SX1509 16-channel GPIO/PWM expander (U503), as detailed in [Table 2-4](#). The expander provides additional GPIOs (carried over the CF3 module’s I2C1 interface) that are used for internal I/O functions such as driving LEDs, resetting board components, etc.

For detailed specifications, see the mangOH Yellow schematics at [mangoh.io/mangoh-yellow-resources-hardware](http://mangoh.io/mangoh-yellow-resources-hardware).

**Table 2-4: GPIO Expander (U503) Signals**

Pin	Signal Name	Purpose
I/O 0	TP500	Test point
I/O 1	WL_REG_ON	Turn on/off Wi-Fi+BT module’s Wi-Fi radio (U300)
I/O 2	TP501	Test point
I/O 3	BT_DEV_WAKE	Wake BT radio (U300)
I/O_4	GENERIC_LED	Generic green LED control (D402)
I/O_5	PCM_EXP_SEL	Connect PCM interface to IoT0 or to PCM codec (audio) via U602
I/O_6	TP502	Test point
I/O_7	TRI_LED1	Generic tri-color LED (D500) (BLUE) control
I/O_8	CARD_DETECT_IOT0	Indicates whether IoT expansion card is present
I/O_9	BATTGAUGE_GPIO	Signal from battery fuel gauge
I/O_10	TRI_LED3	Generic tri-color LED (D500) (RED) control
I/O_11	BAT_VOL_MONITOR	Signal from battery voltage monitor
I/O_12	CHARGER_INT_N	Interrupt from battery charger
I/O_13	MAG_DATA_READY	Geomagnetic sensor data ready
I/O_14	RTC_INT	Interrupt from real-time clock
I/O_15	TRI_LED2	Generic tri-color LED (D500) (GREEN) control

## 2.4.5 HSIC (USB/Ethernet)

The mangOH Yellow supports the CF3 module's HSIC signals, which connect through a USB hub controller to the following sources, as shown in [Figure 2-10](#):

- IoT Connector 0 (CN601)—USB interface
- Wi-Fi+BT module (U300)—UART interface via USB to UART converter (U803)
- Expansion Connector (CN805)—SPI interface via USB/SPI bridge (U805)

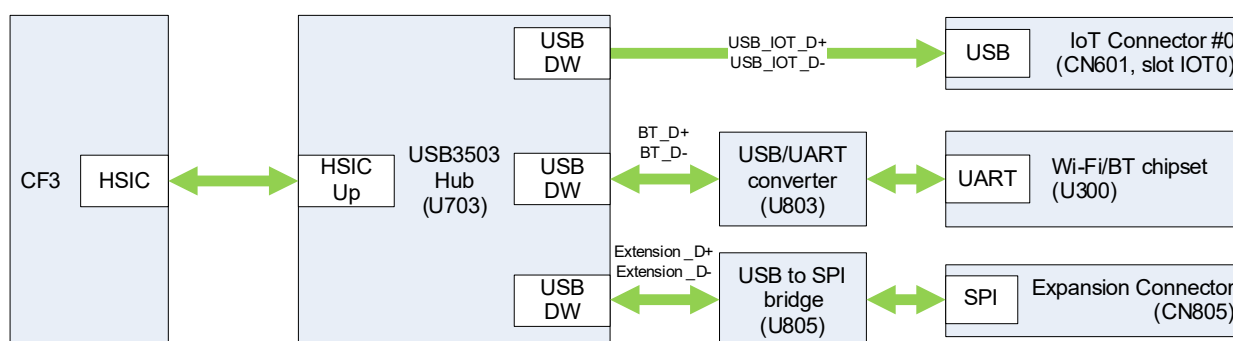

Figure 2-10: HSIC Configuration

## 2.4.6 I2C1

The mangOH Yellow supports CF3 module I2C1 signals, which connect to the following sources (directly or via an I2C expander), as shown in [Figure 2-11](#):

- Direct connection:
  - Audio codec (U702) / 3.5 mm jack (CN701)
- Connection via expander:
  - Gas/Pressure/Humidity/Temperature sensor (U507)
  - Accelerometer/Gyroscope sensor (U520)
  - Geomagnetic Sensor (U502)
  - Light Sensor (U506)
  - Real Time Clock (U701) / Buzzer (U406)
  - NFC (U700)
  - Battery charger (U1000)
  - Battery gauge (U1002)
  - IoT Connector 0 (CN601)
  - Expansion connector (CN805)
  - GPIO/PWM expander (U503)—Used internally on the mangOH Yellow for I/O functions such as driving LEDs, resetting board components, etc. (see [GPIO Expander on page 22](#))
  - For detailed information, refer to mangOH Yellow schematics available at [mangoh.io/mangoh-yellow-resources-hardware](http://mangoh.io/mangoh-yellow-resources-hardware).
- Connection via USB Hub controller (U703):
  - Converts between CF3 HSIC signals and USB signals for the IoT card, Wi-Fi/BT module, and Expansion connector.

All signal sources are enabled by default.

*Note: The mangOH Yellow I2C interface operates in a single-master/multi-slave setup.*

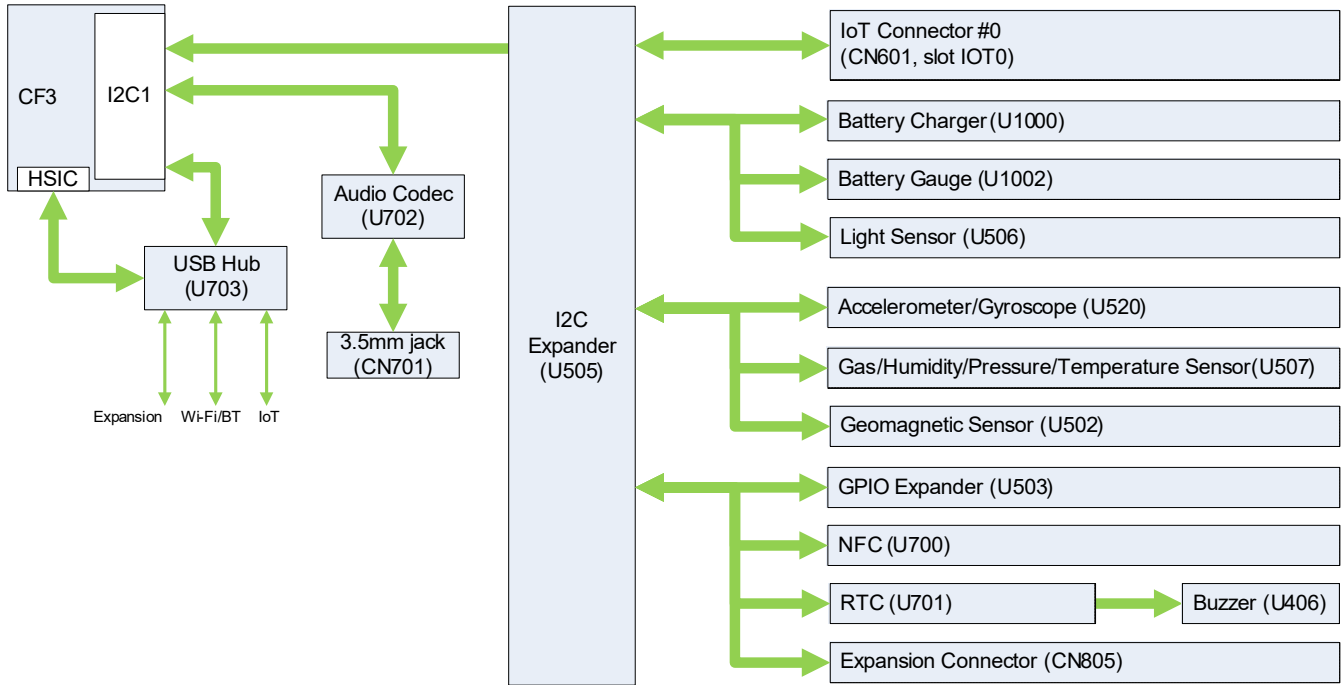

Figure 2-11: I2C1 Configuration

## 2.4.7 Light Sensor

The mangOH Yellow provides a light sensor (U506) that connects to the CF3 module via I2C, as shown in Figure 2-12 and Figure 2-11 on page 24.

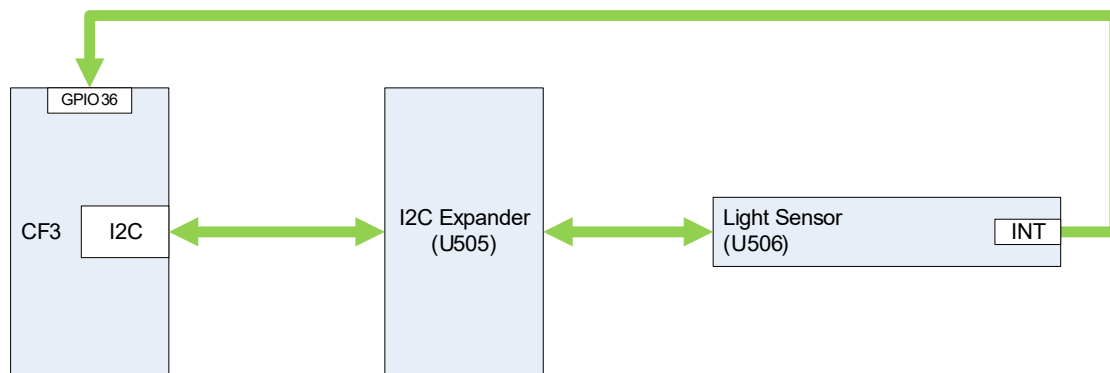

Figure 2-12: Light Sensor Configuration



## 2.4.8 Accelerator/Gyroscope

The mangOH Yellow provides an accelerometer/gyroscope (U520) that connects to the CF3 module via I2C, as shown in [Figure 2-13](#) and [Figure 2-11](#) on page 24.

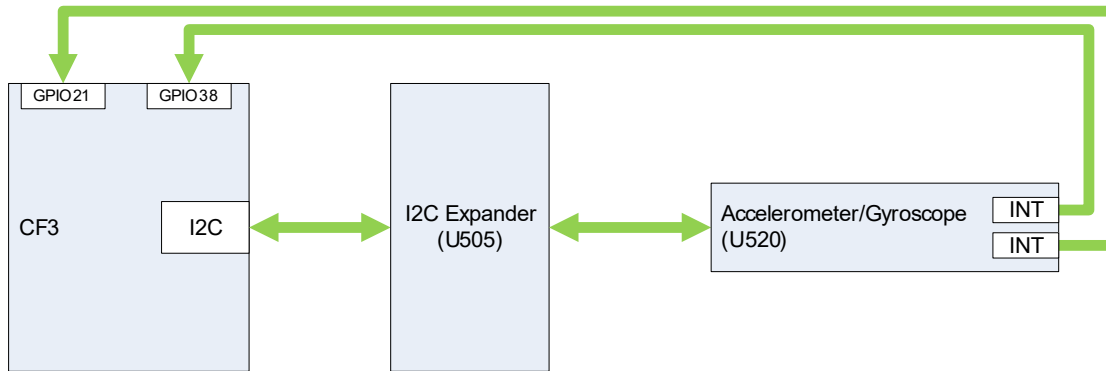

Figure 2-13: Accelerator/Gyroscope Configuration

## 2.4.9 Gas/Humidity/Pressure/Temperature Sensor

The mangOH Yellow provides a gas/humidity/pressure/temperature sensor (U507) that connects to the CF3 module via I2C, as shown in [Figure 2-14](#) and [Figure 2-11](#) on page 24.

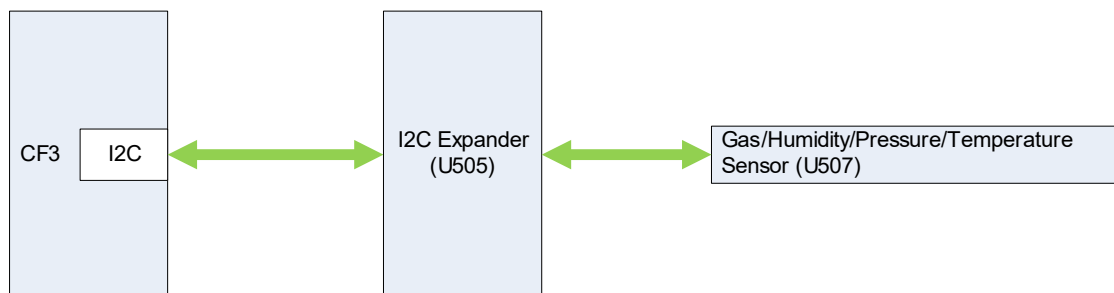

Figure 2-14: Gas/Humidity/Pressure/Temperature Sensor Configuration

## 2.4.10 Geomagnetic Sensor

The mangOH Yellow provides a geomagnetic sensor (U502) that connects to the CF3 module via I2C, as shown in Figure 2-15 and Figure 2-11 on page 24.

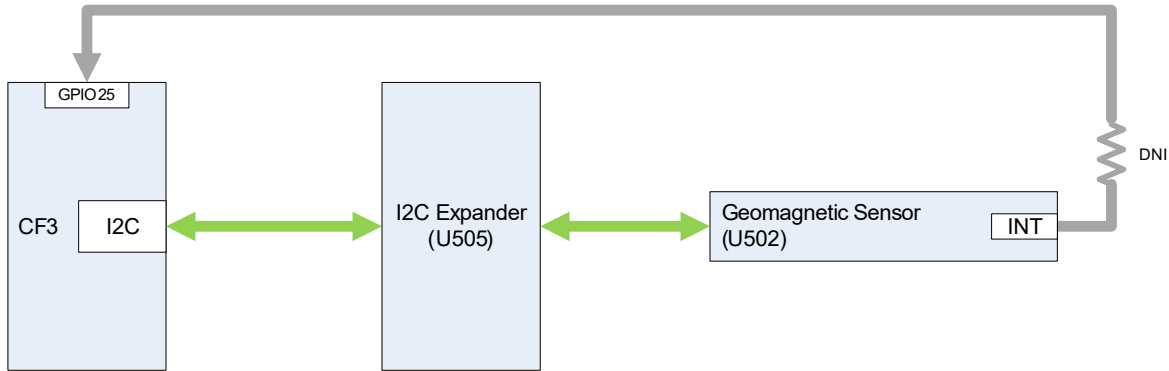

Figure 2-15: Geomagnetic Sensor Configuration

## 2.4.11 RF

The mangOH Yellow provides u.FL antenna connectors and integrated antennas that connect to the CF3 module’s RF signals:

- RF\_MAIN—CN307 (u.FL); ANT300 (Integrated)
- RF\_GPS—CN306 (u.FL); ANT301 (Integrated Wi-Fi/BT + GPS)
- RF\_DIV—CN304 (u.FL)

Power for these signals can be enabled/disabled as described in Table 2-5.

Table 2-5: CF3 RF Interface Configuration Changes

Change type	Change effect	Method	Change duration
Software	Enable/disable RF power for CF3 module	AT command Legato API	
Hardware	Select Main and GPS antennas	SW403: <ul style="list-style-type: none"> <li>• Dip 5—CELL_ANT_CNTR:                             <ul style="list-style-type: none"> <li>• OFF—Integrated (ANT300)</li> <li>• ON—u.FL (CN307)</li> </ul> </li> <li>• Dip 7—GPS_ANT_CNTR:                             <ul style="list-style-type: none"> <li>• OFF—Integrated (ANT301)</li> <li>• ON—u.FL (CN306)</li> </ul> </li> </ul>	mangOH Yellow uses the selected antennas until the dipswitch positions are changed.

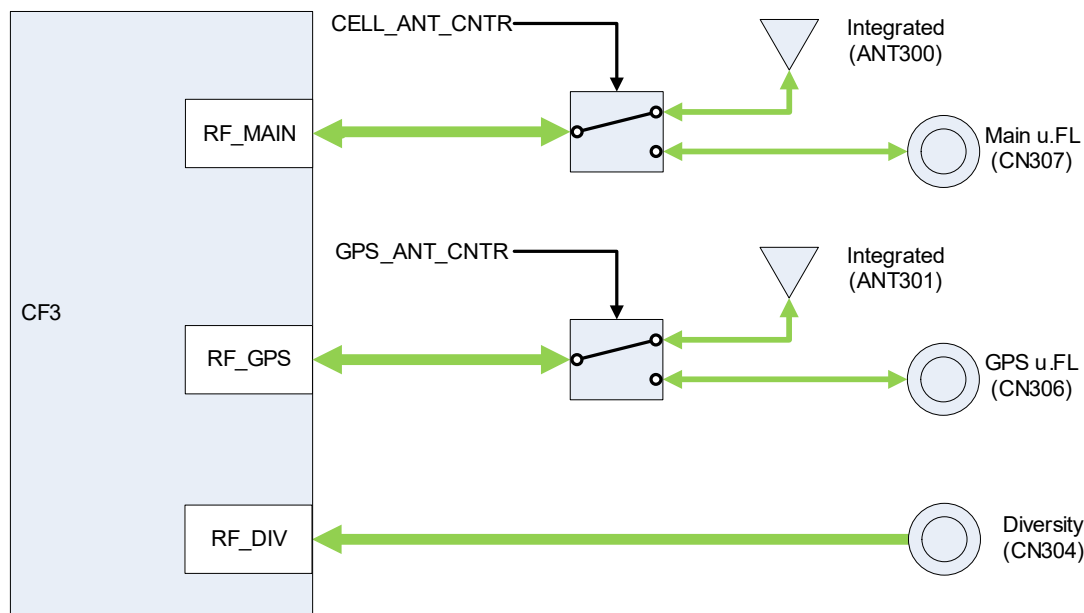

Figure 2-16: CF3 module RF Connections

## 2.4.12 NFC

The mangOH Yellow provides an integrated NTAG I<sup>2</sup>C plus passive tag (U700) and antenna (ANT700) that connect to the CF3 module via I2C, as shown in [Figure 2-11 on page 24](#).

*Note: This is a passive tag. Unlike a reader, it is not an intentional radiator.*

## 2.4.13 Battery

The mangOH Yellow can be powered by an external 3.7 V rechargeable Li-Ion/Li-polymer battery. The battery powers the mangOH Yellow if the selected primary power source is not connected (USB or expansion connector), and recharges automatically if the selected primary power source is connected.

Battery-related components on the mangOH Yellow include:

- External battery connector (CN1000)
- Integrated battery charger (U1000)
- Battery gauge (U1002) that reports the battery's charge level via I2C to the CF3 module
- Voltage supervisor (U1003) that monitors the battery's voltage and, when the voltage level is out of range (<3.1V or >3.6V), will assert RESET\_IN to hold the CF3 module in reset until the battery is sufficiently recharged.

The CF3 module interacts via I2C with both the battery charger and the battery gauge, as shown in [Figure 2-11 on page 24](#).

## 2.4.14 RTC

The mangOH Yellow provides a low power consumption CMOS Real-Time Clock (RTC) (U701) that connects to the CF3 module via I2C, as shown in [Figure 2-11 on page 24](#).

The RTC provides basic functionality (provides clock (year, month, day, weekday, hours, minutes, seconds) and calendar), and includes a clock output signal (CLKOUT) that connects to a buzzer (2.4.15 Buzzer) for user-defined purposes.

## 2.4.15 Buzzer

The mangOH Yellow includes an integrated buzzer (U406) for user-defined use. The buzzer is activated by the RTC clock output signal (CLKOUT).

## 2.4.16 Expansion Connector

The mangOH Yellow provides a 15-pin expansion connector (CN805) that can be used to connect an external device to the mangOH Yellow. The expansion connector includes several pins that connect to the CF3 module's signals as detailed in Table 2-6.

*Note: All signals (pins 2–14) are 3.3 V.*

For additional information, including default configuration and how to temporarily change it, see [Expansion Connector Interfaces on page 35](#).

**Important:** Do not use the UART connections on both the IoT card ([IoT Expansion Card on page 16](#)) and a device via the expansion connector to the mangOH Yellow at the same time.

**Table 2-6: Expansion Connector Signal Connections to CF3 Module**

Expansion Pins	CF3/Other Signal(s)		Notes
	Signal	Mux	
Output Power (Expansion to mangOH Yellow) (Pin 1)	VIN_CONN	n/a	Purpose: Connected device provides power to the mangOH Yellow when Power Supply Selector (CN801) jumper is on pins 2–3. For details, see <a href="#">Power Management on page 37</a> .
Reset (Pin 2)	SYSTEM_RESET via: <ul style="list-style-type: none"> <li>LOWPOWER_RESET (CF3 GPIO6)</li> <li>Reset button (SW401)</li> </ul>	n/a	Purpose: Input from mangOH Yellow to reset the connected device.
SPI (Pins 3–6)	HSIC (Pins 14–15)	No	Purpose: Data transfer; application control. For details, see <a href="#">HSIC (USB/Ethernet) on page 23</a> .
UART (Pins 7–8)	UART1 (Pins 5–6)		Purpose: Data transfer via 2-pin UART interface (Tx/Rx). For details, see <a href="#">UART1 on page 30</a> .
ADC (Pin 9)	ADC2 (Pin 107)	No	Purpose: General purpose ADC output to host application (e.g. indicate when a sensor has triggered). For details, see <a href="#">ADC on page 19</a> .
I2C (Pins 10–11)	I2C1 (Pins 1, 66)	Hub	Purpose: Data transfer (standard mode). Higher speeds possible if supported by host application. For details, see <a href="#">I2C1 on page 23</a> .

**Table 2-6: Expansion Connector Signal Connections to CF3 Module (Continued)**

Expansion Pins	CF3/Other Signal(s)		Notes
	Signal	Mux	
GPIO (Pins 12–13)	GPIO_24 (Pin 150) GPIO_33 (Pin 105)		Purpose: User-defined GPIOs
Input Power (mangOH Yellow to Expansion) (Pin 14)	VCC_3V3	n/a	Purpose: Power provided by mangOH Yellow to connected device.
Ground (Pin 15)	Ground		

## 2.4.17 SDIO

The mangOH Yellow supports the CF3 module SDIO signals, which connect via a MUX (controlled by SW403 pin 8 SDIO\_SEL2) to the following sources, as shown in [Figure 2-17](#):

- Wi-Fi+BT module (U300)
- microSD card connector (CN602)
- IoT card connector (CN601)

If SDIO\_SEL2 is:

- OFF—If a microSD card or IoT card is inserted, use that card as the SDIO slave, otherwise use the Wi-Fi/BT module.
- ON—Use the microSD card or IoT card as the SDIO slave. The Wi-Fi/BT module will not be used.

---

**Important:** Only one card can be inserted (either a microSD card or an IoT card). The SDIO interface will not work if both cards are inserted.

---

The SDIO interface configuration can be modified as detailed in [Table 2-7](#).

**Table 2-7: SDIO Interface Configuration Changes**

Change type	Change effect	Method	Change duration
Hardware	As described above.	SW403 pin 8 SDIO_SEL2	SDIO slave selection occurs during module boot based on the SDIO_SEL2 switch position. If the switch is changed while booted, reboot the module for the change to take effect.

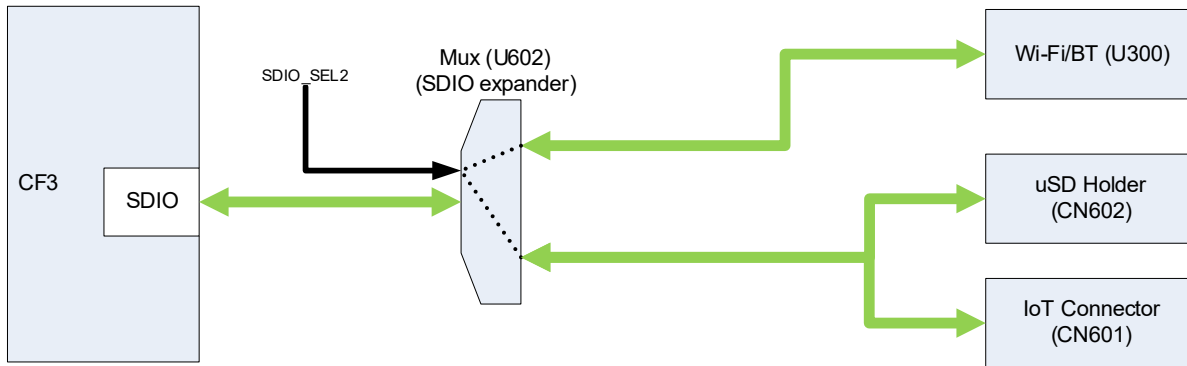

Figure 2-17: SDIO Configuration

## 2.4.18 SPI1

The mangOH Yellow supports the CF3 module's SPI1 signals, which connect to the IoT Connector (CN601) as shown in [Figure 2-18](#).

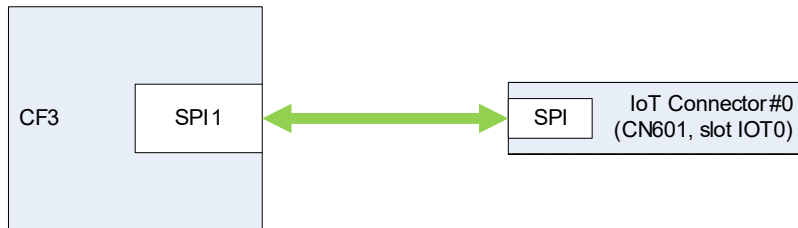

Figure 2-18: SPI1 Configuration

## 2.4.19 UART0

When the mangOH Yellow is in HL78 mode (SW403 pin 1 HL78\_MODE\_ON selected), UART0 is used to connect to the Console USB connector (CN800) as shown in [Figure 2-19](#).

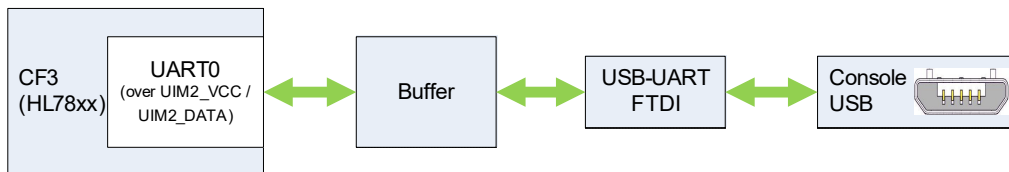

Figure 2-19: UART0 Configuration

## 2.4.20 UART1

The mangOH Yellow supports the CF3 module's UART1 signals, which connect to the IoT Connector (CN601) and Expansion Connector (CN805) as shown in [Figure 2-20](#).

**Important:** Do not use the UART connections on both an IoT card and a device via the expansion connector to the mangOH Yellow at the same time.

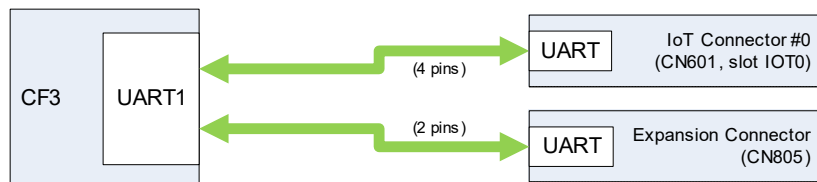

Figure 2-20: UART1 Configuration

## 2.4.21 UART2

The mangOH Yellow supports the CF3 module's UART2 signals, which connect to the Console USB connector (CN800), as shown in [Figure 2-21](#).

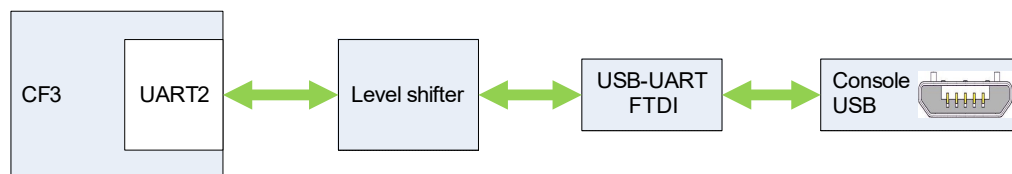

Figure 2-21: UART2 Configuration

## 2.4.22 UIM

The mangOH Yellow supports the CF3 module's UIM1 interface, as shown in [Figure 2-22](#).

---

*Note: Throughout this document, 'UIM' is used to refer to UIM, USIM, SIM, UICC.*

---

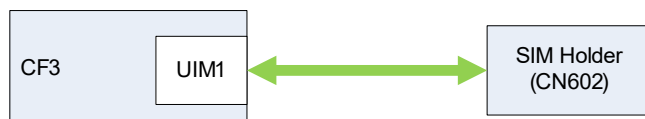

Figure 2-22: UIM1 Interface Configuration

The CF3 module's UIM1 signals connect to the micro-SIM holder (CN602).

---

*Note: The CF3 module's UIM1\_DET signal indicates when a SIM is present in the holder.*

---

## 2.4.23 USB 2.0

The CF3 module's USB signal connects directly to the mangOH Yellow's micro-USB connector (CN802) as shown in [Figure 2-23](#), for control by a connected computer.

---

*Note: The micro-USB connector also acts as a power source, if selected. See [Power Management on page 37](#).*

---

The USB 2.0 interface configuration can be modified as detailed in [Table 2-8](#).

**Table 2-8: USB 2.0 Interface Configuration Methods**

Change type	Change effect	Method	Change duration
Hardware	<ul style="list-style-type: none"> <li>Jumper on CN801 pins 1–2 — Select CF3 Client USB power</li> <li>Jumper on CN801 pins 2–3— Select Expansion Connector power (or CON USB connector, if resistors have been populated/ depopulated)</li> </ul>	Position jumper on CN801 to choose Client USB or Expansion Connector to supply power.  <i>Note: mangOH Yellow ships with USB power connector selected (jumper on pins closest to USB connector).</i>	mangOH Yellow uses the selected power supply until the jumper changes.



Figure 2-23: USB\_2.0 Configuration

## 2.5 Wi-Fi+BT Module

The mangOH Yellow incorporates a Wi-Fi+BT module (USI Wi-Fi+Bluetooth) that provides the following functionality, as show in [Figure 2-24](#):

- RF:
  - Wi-Fi/Bluetooth connections via mangOH Yellow u.FL antenna connector or integrated 2.4 GHz antenna
  - Supports 2.4 GHz Wi-Fi (802.11b/g; 802.11n (HT20 only)) and 2.4 GHz BLE (Bluetooth Low Energy)
- Wi-Fi interface SDIO connection to CF3
- Wi-Fi and BT interface control signals via CF3 module and GPIO Expander GPIOs
- BT UART interface connection to CF3 HSIC interface

*Note: Wi-Fi/BT operating frequency ranges and output power levels are not user-configurable.*



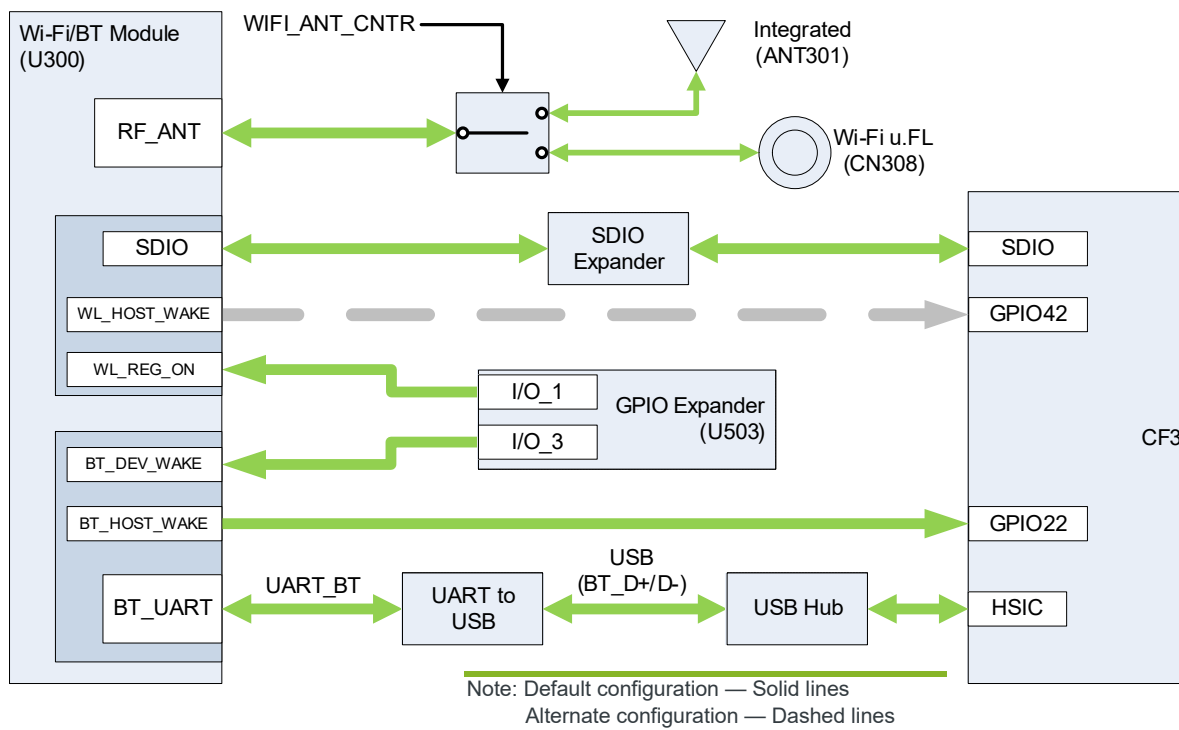

Figure 2-24: Wi-Fi+BT Module Connections

## 2.5.1 Wi-Fi RF

The mangOH Yellow supports 2.4GHz Wi-Fi (802.11b/g; 802.11n (HT20 only)).

For full Wi-Fi 2.4 GHz RF receiver/transmitter specifications, refer to the Cypress CYW43364 datasheet or the WM-BN-CYW-48\_REF1\_Module Datasheet\_V1.1 from USI. (The USI chip is a SIP package that contains the CYW43364 (Wi-Fi) and CYW20719 (Bluetooth) chips.)

## 2.5.2 Bluetooth RF

The mangOH Yellow supports 2.4GHz BLE (Bluetooth Low Energy).

For full Bluetooth 2.4 GHz RF receiver/transmitter specifications, refer to the Cypress CYW20719 datasheet or the WM-BN-CYW-48\_REF1\_Module Datasheet\_V1.1 from USI. (The USI chip is a SIP package that contains the CYW43364 (Wi-Fi) and CYW20719 (Bluetooth) chips.)

## 2.6 IoT Connector Interfaces

The mangOH Yellow provides one IoT Connector (CN601), which supports the signals defined in the Project mangOH IoT Expansion Card Design Specification, as detailed in [Table 2-2 on page 16](#).

The default configuration (enabled signals) for the IoT Connector is shown in [Figure 2-25](#).

The IoT Connector interface configuration can be modified as detailed in [Table 2-9](#).

**Table 2-9: IoT Connector Interface Configuration Changes**

Change type	Change effect	Method	Change duration
Software	Enable/disable identified signal(s) on a specific IoT Connector.	API command	Modifies running configuration until device reboots or another change is made.

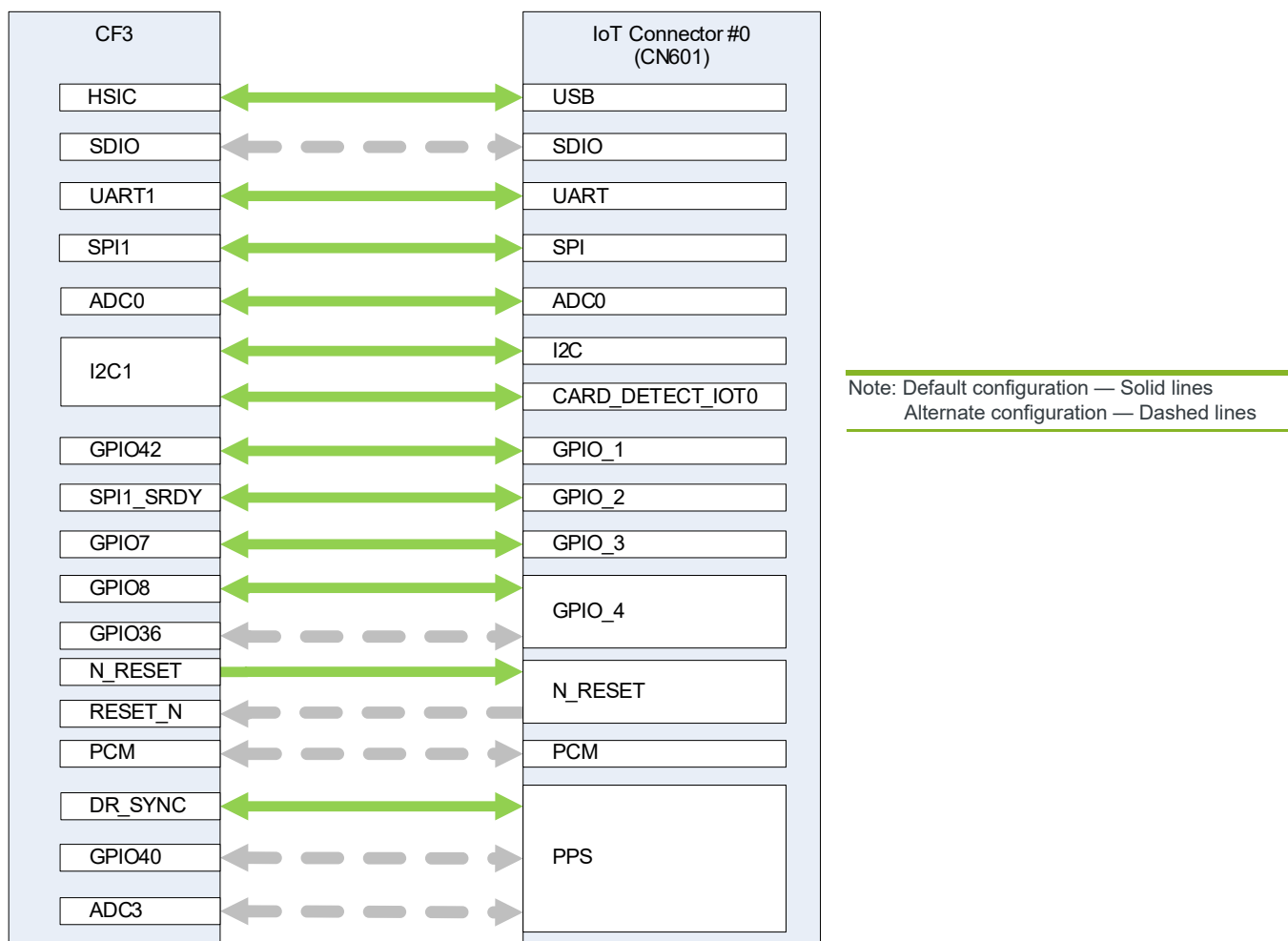

Figure 2-25: IoT Connector Configuration

## 2.7 Expansion Connector Interfaces

The mangOH Yellow provides an expansion connector (CN805), that can be used to connect an external device to the mangOH Yellow. The external device can be powered by the mangOH Yellow, or the mangOH Yellow can be powered by the external device.

The default configuration (enabled signals) for the expansion connector is shown in [Figure 2-26](#).

The Expansion Connector interface configuration can be modified as detailed in [Table 2-10](#).

**Table 2-10: Expansion Connector Interface Configuration Changes**

Change type	Change effect	Method	Change duration
Hardware	<ul style="list-style-type: none"> <li>Jumper on CN801 pins 1–2 — Select CF3 Client USB power</li> <li>Jumper on CN801 pins 2–3— Select Expansion Connector power (or CON USB connector if resistor populated/ depopulated—see next row for details).</li> </ul>	Position jumper on CN801 to choose Client USB or Expansion Connector to supply power.  <i>Note: mangOH Yellow ships with USB power connector selected (jumper on pins closest to USB connector).</i>	mangOH Yellow uses the selected power supply until the jumper changes.
	<ul style="list-style-type: none"> <li>Use CON USB connector for power instead of Expansion Connector.</li> </ul>	Populate R809, depopulate R800	

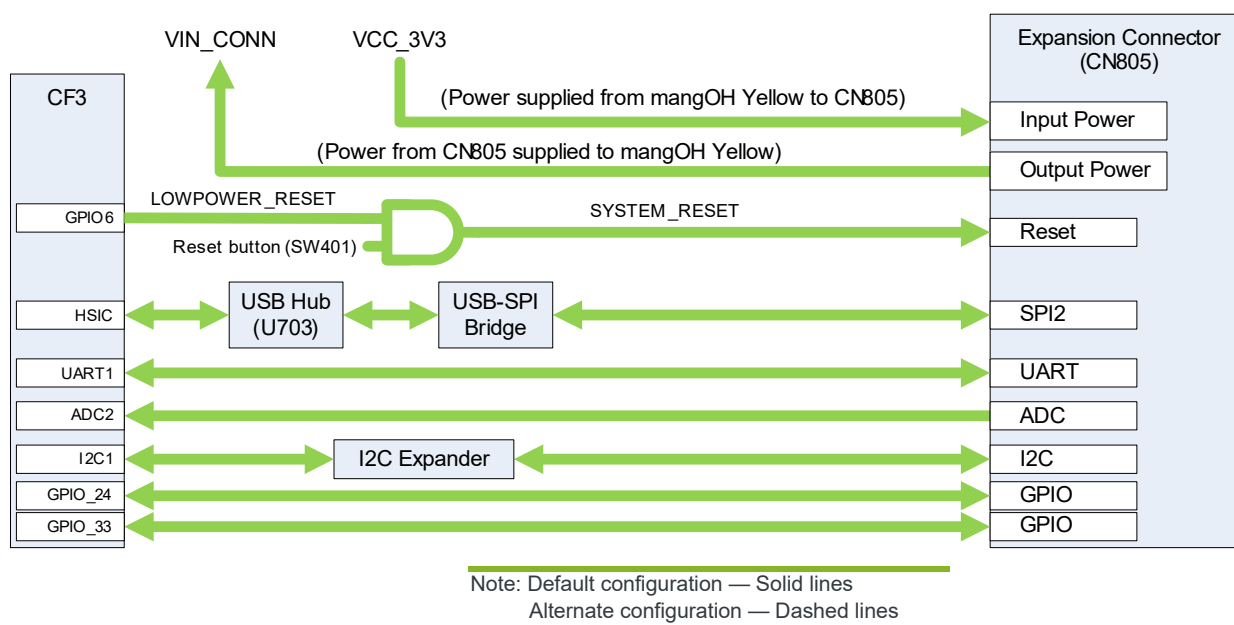

Figure 2-26: Expansion Connector Configuration

## 2.8 Reset Methods

The mangOH Yellow supports hardware and software resets of the entire board or certain components of the board, as shown in [Figure 2-27](#):

**Table 2-11: Reset Methods**

Board Components to Reset	Reset Method
Entire board, including CF3 module (WP or HL)	Press Reset button (SW401) to trigger the module signal RESET_IN. <i>Note: RESET_IN can also be triggered by the IoT connector (CN601) if a hardware modification is made to populate resistor R630. Refer to the mangOH Yellow schematic for details.</i>
All components except CF3 module	Use an API command to trigger the module signal LOWPOWER_RESET.
IOT Expansion Card	Use an API command to trigger the CF3 module signal GPIO_IOT0_RESET.
Wi-Fi+BT module	Wi-Fi Reset—Not currently supported.
	BT Reset—Use an API command to trigger the CF3 module signal GPIO_BT_RESET.

The mangOH Yellow also will switch off automatically if operating under battery power and the battery voltage drops below 3.1V, and will remain off while the battery voltage is < 3.6V.

For detailed specifications showing how full or partial resets are enabled, see the mangOH Yellow schematics available at [mangoh.io/mangoh-yellow-resources-hardware](http://mangoh.io/mangoh-yellow-resources-hardware).

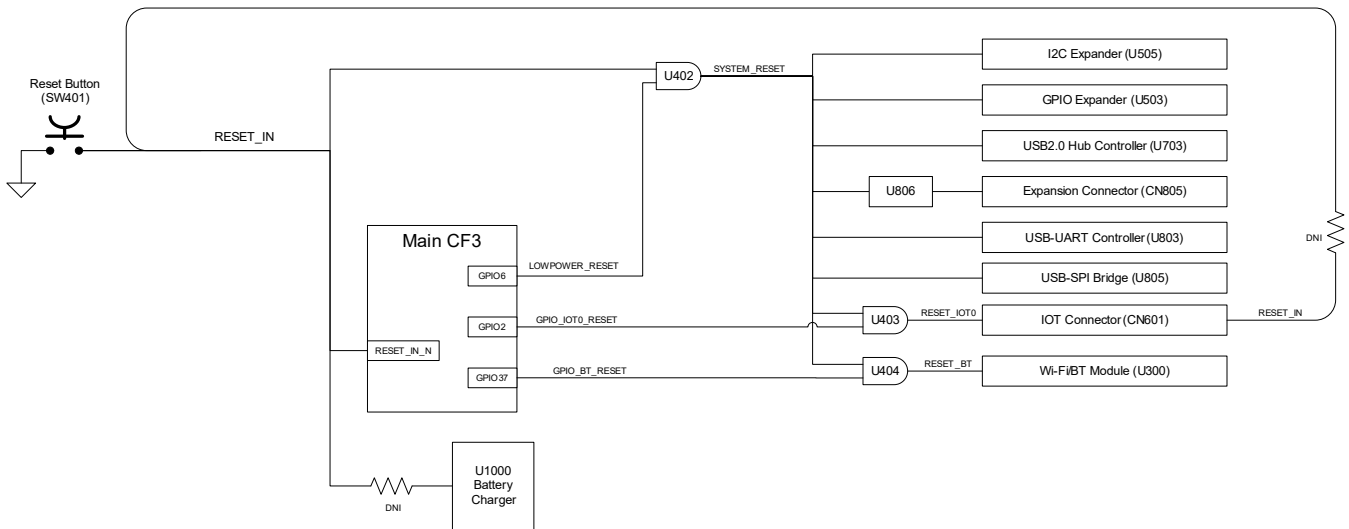

Figure 2-27: Reset Methods

## 2.9 Power Management

The mangOH Yellow has two primary power supplies (the micro-USB Client connector and Expansion connector), and a rechargeable backup battery power supply option. The hardware can also be reconfigured to replace the Expansion connector with the micro-USB Console connector as a primary supply. [Figure 2-28](#) illustrates these power supplies, their voltage/current specifications, and how they supply various components on the mangOH Yellow platform.

**Table 2-12: Power Configuration Changes**

Change type	Change effect	Method	Change duration
Hardware	Change VIN source from expansion connector power pin to micro-USB Console connector.	Populate R809, depopulate R800	Permanent

The power switch is used to turn the mangOH Yellow on/off, regardless of which power supply is being used.

**Table 2-13: Power Switch Options**

Primary power connected	Battery connected	Switch Position (Toward center—ON toward outside—OFF)	Result
No	No	Any	No power to board, switch has no effect.
Yes	No	Center (ON)	Primary power supplied to board.
		Outside (OFF)	Board is off.
Yes	Yes	Center (ON)	Primary power supplied to board. Battery recharges automatically.
		Outside (OFF)	Board is off.
No	Yes	Center (ON)	Battery power supplied to board.
		Outside (OFF)	Board is off.

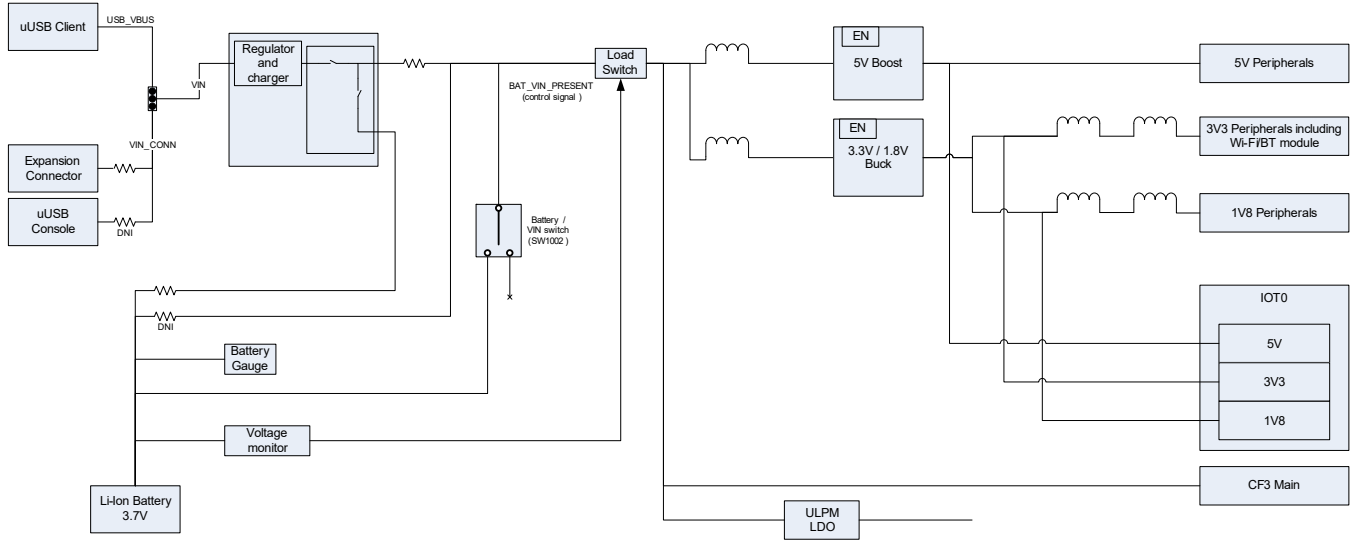

Figure 2-28: Power Management

## 3: Signal Name Variations

The mangOH Yellow schematic (available at [mangoh.io/mangoh-yellow-resources-hardware](http://mangoh.io/mangoh-yellow-resources-hardware)), describes all interfaces supported by the mangOH Yellow.

The following table identifies signal naming differences between the CF3 standard, the mangOH Yellow, and WP7702 modules.

**Table 3-1: Interface Variations**

Pin	CF3	Signal Names	
		mangOH	WP7702 <sup>a</sup>
10	GPIO2	GPIO_IOT0_RESET	GPIO2
11	RESET_N	RESET_IN	RESET_IN_N
16	USB_VBUS	VBATT_BB (alt: USB_VBUS)	USB_VBUS
21	BAT_RTC	BAT_RTC (TP)	Reserved
22	SYSTEM_CLK	SYSTEM_CLK	SYS_CLK
23	SLEEP_CLK	32K_CLK	SLEEP_CLK
29	UIM1_RESET	UIM1_RESET	UIM1_RESET_N
31	RF_DIV	RF_DIV	Reserved
38	RF_GPS	RF_GPS	RF_GNSS
40	GPIO7	IOT0_GPIO3	GPIO7
41	GPIO8	IOT0_GPIO4	GPIO8
42	DR_SYNC	PPS	DR_SYNC
43	EXT_LNA_GPS_EN	EXT_LNA_GPS_EN	EXT_GPS_LNA_EN
44	GPIO13	IOT0_GPIO2	GPIO13
46	RESET_OUT_N	LowPower_RESET	GPIO6 (alt: RESET_OUT_N)
47	TP1 (BOOT)	TP1_BOOT	TP1 (Boot pin)
55	UIM2_VCC	UART0_RX	Reserved
56	UIM2_DATA	UART0_TX	Reserved
57	UIM2_RESET	UART0_CTS	Reserved
58	UIM2_CLK	UART0_RTS	Reserved
59	POWER_ON_N	POWER_ON	POWER_ON_N
61	VBATT_RF1	VBATT_RF	VBAT_RF
62	VBATT_RF2	VBATT_RF	VBAT_RF
63	VBAT_BB1	VBATT_BB	VBAT_BB

**Table 3-1: Interface Variations (Continued)**

Pin	Signal Names		
	CF3	mangOH	WP7702 <sup>a</sup>
64	UIM1_DET	TP203	UIM1_DET
65	UIM2_DET	NC	GPIO4
66	I2C1_DATA	I2C1_DATA_CF3	I2C1_Data
92	GPIO38	ACC_SENSOR_INT1	GPIO38
93	GPIO39	NC	Reserved
94	GPIO40	GPIO_40	GPIO40
95	GPIO41	BUCK_CONV_EN	GPIO41
100	GPIO34	NC	Reserved
101	GPIO35	TP	GPIO35
103	GPIO37	GPIO_BT_RESET	GPIO37
104	GPIO32	GPIO_EXP_INT	GPIO32
105	GPIO33	GPIO_33	GPIO33
106	LED1_N	WWAN_LED_N	WWAN_LED_N
107	ADC2	ADC2_1V8	ADC2
109	GPIO42	GPIO_42	GPIO42
147	GPIO21	ACC_SENSOR_INT2	GPIO21
148	GPIO22	BT_HOST_WAKEUP	GPIO22
149	GPIO23	NFC_INT0	GPIO23
150	GPIO24	GPIO_24	GPIO24
152	SAFE_PWR_REMOVE	PWR_IND	SAFE_POWR_REMOVE
153	GPIO28	ANT_CTL_0	ANT_CNTL0
154	GPIO29	ANT_CTL_1	ANT_CNTL1
155	GPIO30	ANT_CTL_2	ANT_CNTL2
156	GPIO31	ANT_CTL_3	ANT_CNTL3
157	VBATT_RF3	VBATT_RF	VBAT_RF
158	VBATT_BB2	VBATT_BB	VBAT_BB
159	GPIO25	GENERIC_BUTTON (dnp: MAG_SENSOR_INT)	GPIO25
161	SDCC_CMD	SD_CMD	SDIO_CMD
162	SDCC_CLK	SD_CLK	SDIO_CLK
163	SDCC_DATA_3	SD_D3	SDIO_DATA_3
164	SDCC_DATA_2	SD_D2	SDIO_DATA_2



**Table 3-1: Interface Variations (Continued)**

Pin	CF3	Signal Names	
		mangOH	WP7702 <sup>a</sup>
165	SDCC_DATA_1	SD_D1	SDIO_DATA_1
166	SDCC_DATA_0	SD_D0	SDIO_DATA_0

a. For detailed information, refer to the module's Product Technical Specification documents at [source.sierrawireless.com](http://source.sierrawireless.com).