



**FCC OET BULLETIN 65 SUPPLEMENT C
IC RSS-102 ISSUE 2**

SAR EVALUATION REPORT

For

USB WIRELESS MODEM

MODEL: USB306

FCC ID: N7NU306

IC: 2417C-U306

REPORT NUMBER: 09U12651-3A

ISSUE DATE: September 22, 2009

Prepared for

SIERRA WIRELESS, INC

13811 WIRELESS WAY

RICHMOND, BC V6V 3A4 CANADA

Prepared by

COMPLIANCE CERTIFICATION SERVICES

47173 BENICIA STREET

FREMONT, CA 94538, U.S.A.

TEL: (510) 771-1000

FAX: (510) 661-0888



NVLAP LAB CODE 200065-0

Revision History

Rev.	Issue Date	Revisions	Revised By
--	June 22, 2009	Initial Issue	--
A	September 22, 2009	1. Corrected typos in Section 10.4 2. Added note under power table in Section 10.4, page 24.	Sunny Shih

TABLE OF CONTENTS

1. ATTESTATION OF TEST RESULTS	5
2. TEST METHODOLOGY	6
3. FACILITIES AND ACCREDITATION	6
4. CALIBRATION AND UNCERTAINTY	7
4.1. <i>MEASURING INSTRUMENT CALIBRATION</i>	7
4.2. <i>MEASUREMENT UNCERTAINTY</i>	8
5. EQUIPMENT UNDER TEST	9
6. SYSTEM SPECIFICATIONS	10
7. COMPOSITION OF INGREDIENTS FOR TISSUE SIMULATING LIQUIDS	11
8. LIQUID PARAMETERS CHECK	12
8.1. <i>LIQUID CHECK RESULTS FOR 1900 MHZ</i>	13
8.2. <i>LIQUID CHECK RESULTS FOR 835 MHZ</i>	16
9. SYSTEM CHECK	18
9.1. <i>SYSTEM CHECK RESULTS FOR D1900V2</i>	19
9.2. <i>SYSTEM CHECK RESULTS FOR D835V2</i>	19
10. OUTPUT POWER VERIFICATION	20
10.1. <i>GSM</i>	20
10.2. <i>UMTS RELEASE 99</i>	21
10.3. <i>UMTS HSDPA</i>	22
10.4. <i>UMTS Rel 6 HSPA (HSDPA & HSUPA)</i>	23
11. SUMMARY OF TEST RESULTS	25
11.1. <i>UMTS BAND II (1900 MHZ)</i>	25
11.1.1. Horizontal Up.....	25
11.1.2. Horizontal Down	25
11.1.3. Vertical Front	25
11.1.4. Vertical Back.....	25
11.2. <i>GSM1900</i>	26
11.2.1. Horizontal Up.....	26
11.2.2. Horizontal Down	26
11.2.3. Vertical Front	26
11.2.4. Vertical Back.....	26
11.3. <i>UMTS BAND V (850 MHZ)</i>	27
11.3.1. Horizontal Up.....	27

11.3.2.	Horizontal Down	27
11.3.3.	Vertical Front	27
11.3.4.	Vertical Back.....	27
11.4.	GSM850	28
11.4.1.	Horizontal Up.....	28
11.4.2.	Horizontal Down	28
11.4.3.	Vertical Front	28
11.4.4.	Vertical Back.....	28
12.	WORST-CASE SAR TEST PLOTS	29
13.	ATTACHMENTS	31
14.	TEST SETUP PHOTO	32
15.	EUT EXTERNAL PHOTO	34

1. ATTESTATION OF TEST RESULTS

COMPANY NAME: SIERRA WIRELESS, INC
 13811 WIRELESS WAY
 RICHMOND, BC V6V 3A4 CANADA

EUT DESCRIPTION: USB wireless modem

MODEL NUMBER: USB306

DEVICE CATEGORY: Portable

EXPOSURE CATEGORY: General Population/Uncontrolled Exposure

DATE TESTED: June 15 – 19, 2009

THE HIGHEST SAR VALUES:

FCC / IC Rule Parts	Frequency Range [MHz]	The Highest SAR Values (1g_mW/g)	Limit (mW/g)
22H / RSS-132	824 - 849	0.836 (Horizontal down)	1.6
24E / RSS-133	1850 - 1910	1.50 (Horizontal up)	

APPLICABLE STANDARDS AND TEST PROCEDURES:

STANDARDS AND TEST PROCEDURES	TEST RESULTS
<ul style="list-style-type: none"> • FCC OET Bulletin 65 Supplement C and the following specific Test Procedures: <ul style="list-style-type: none"> ○ KDB 941225 D01 SAR test for 3G devices ○ 447498 D01 Mobile Portable RF Exposure v03r03 ○ 447498 D02 SAR Procedures for Dongle Xmtr v01 	Pass
<ul style="list-style-type: none"> • RSS-102 ISSUE 2 	Pass

Compliance Certification Services, Inc. (CCS) tested the above equipment in accordance with the requirements set forth in the above standards. All indications of Pass/Fail in this report are opinions expressed by CCS based on interpretations and/or observations of test results. Measurement Uncertainties were not taken into account and are published for informational purposes only. The test results show that the equipment tested is capable of demonstrating compliance with the requirements as documented in this report.

Note: The results documented in this report apply only to the tested sample, under the conditions and modes of operation as described herein. This document may not be altered or revised in any way unless done so by CCS and all revisions are duly noted in the revisions section. Any alteration of this document not carried out by CCS will constitute fraud and shall nullify the document. This report must not be used by the client to claim product certification, approval, or endorsement by NVLAP, NIST, any agency of the Federal Government, or any agency of any government.

Approved & Released For CCS By:

Tested By:

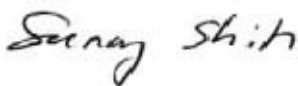

SUNNY SHIH
 ENGINEERING SUPERVISOR
 COMPLIANCE CERTIFICATION SERVICES

CHAO YEN LIN
 EMC ENGINEER
 COMPLIANCE CERTIFICATION SERVICES

2. TEST METHODOLOGY

The tests documented in this report were performed in accordance with FCC OET Bulletin 65 Supplement C, IC RSS 102 Issue 2 and the following specific FCC Test Procedures.

- KDB 941225 D01 SAR test for 3G devices
- 447498 D01 Mobile Portable RF Exposure v03r03
- o447498 D02 SAR Procedures for Dongle Xmtr v01

3. FACILITIES AND ACCREDITATION

The test sites and measurement facilities used to collect data are located at 47173 Benicia Street, Fremont, California, USA.

CCS is accredited by NVLAP, Laboratory Code 200065-0. The full scope of accreditation can be viewed at <http://ts.nist.gov/Standards/scopes/2000650.htm>.

4. CALIBRATION AND UNCERTAINTY

4.1. MEASURING INSTRUMENT CALIBRATION

The measuring equipment utilized to perform the tests documented in this report has been calibrated in accordance with the manufacturer's recommendations, and is traceable to recognized national standards.

Name of Equipment	Manufacturer	Type/Model	Serial No.	Cal. Due date		
				MM	DD	Year
Robot - Six Axes	Stäubli	RX90BL	N/A	N/A		
Robot Remote Control	Stäubli	CS7MB	3403-91535	N/A		
DASY4 Measurement Server	SPEAG	SEUMS001BA	1041	N/A		
Probe Alignment Unit	SPEAG	LB (V2)	261	N/A		
SAM Phantom (SAM1)	SPEAG	QD000P40CA	1185	N/A		
SAM Phantom (SAM2)	SPEAG	QD000P40CA	1050	N/A		
Oval Flat Phantom (ELI 4.0)	SPEAG	QD OVA001 B	1003	N/A		
Electronic Probe kit	HP	85070C	N/A	N/A		
S-Parameter Network Analyzer	Agilent	8753ES-6	MY40001647	11	14	2009
Signal Generator	Agilent	8753ES-6	MY40001647	11	14	2009
E-Field Probe	SPEAG	EX3DV4	3686	3	23	1010
Thermometer	ERTCO	639-1S	1718	5	1	2010
Data Acquisition Electronics	SPEAG	DAE3 V1	427	10	20	2009
System Validation Dipole	SPEAG	D835V2	4d002	6	22	2009
System Validation Dipole	SPEAG	D900V2	108	1	21	2010
System Validation Dipole	SPEAG	D1800V2	294	1	29	2010
System Validation Dipole	SPEAG	D1900V2	5d043	1	29	2010
System Validation Dipole	SPEAG	D2450V2	748	4	14	2010
System Validation Dipole	SPEAG	D5GHzV2	1003	11	21	2009
MXA Signal Analyzer	Agilent	N9020A	US48350984	10	23	2009
ESG Vector Signal Generator	Agilent	E4438C	US44271090	9	17	2010
Power Meter	Giga-tronics	8651A	8651404	1	11	2010
Power Sensor	Giga-tronics	80701A	1834588	1	11	2010
Amplifier	Mini-Circuits	ZVE-8G	90606	N/A		
Amplifier	Mini-Circuits	ZHL-42W	D072701-5	N/A		
Simulating Liquid	CCS	H1900	N/A	Within 24 hrs of first test		
Simulating Liquid	CCS	M1900	N/A	Within 24 hrs of first test		
Simulating Liquid	CCS	H1800	N/A	Within 24 hrs of first test		
Simulating Liquid	CCS	M1800	N/A	Within 24 hrs of first test		
Simulating Liquid	CCS	H1700	N/A	Within 24 hrs of first test		
Simulating Liquid	CCS	M1700	N/A	Within 24 hrs of first test		
Simulating Liquid	CCS	H835	N/A	Within 24 hrs of first test		
Simulating Liquid	CCS	M835	N/A	Within 24 hrs of first test		
Simulating Liquid	CCS	H900	N/A	Within 24 hrs of first test		
Simulating Liquid	CCS	M900	N/A	Within 24 hrs of first test		

4.2. MEASUREMENT UNCERTAINTY

Measurement uncertainty for 300 MHz – 3000 MHz

Uncertainty component	Tol. ($\pm\%$)	Probe Dist.	Div.	Ci (1g)	Ci (10g)	Std. Unc.($\pm\%$)		
						Ui (1g)	Ui(10g)	
Measurement System								
Probe Calibration	4.80	N	1	1	1	4.80	4.80	
Axial Isotropy	4.70	R	1.732	0.707	0.707	1.92	1.92	
Hemispherical Isotropy	9.60	R	1.732	0.707	0.707	3.92	3.92	
Boundary Effects	1.00	R	1.732	1	1	0.58	0.58	
Linearity	4.70	R	1.732	1	1	2.71	2.71	
System Detection Limits	1.00	R	1.732	1	1	0.58	0.58	
Readout Electronics	1.00	N	1	1	1	1.00	1.00	
Response Time	0.80	R	1.732	1	1	0.46	0.46	
Integration Time	2.60	R	1.732	1	1	1.50	1.50	
RF Ambient Conditions - Noise	1.59	R	1.732	1	1	0.92	0.92	
RF Ambient Conditions - Reflections	0.00	R	1.732	1	1	0.00	0.00	
Probe Positioner Mechanical Tolerance	0.40	R	1.732	1	1	0.23	0.23	
Probe Positioning With Respect to Phantom Shell	2.90	R	1.732	1	1	1.67	1.67	
algorithms for max. SAR evaluation	3.90	R	1.732	1	1	2.25	2.25	
Test sample Related								
Test Sample Positioning	1.10	N	1	1	1	1.10	1.10	
Device Holder Uncertainty	3.60	N	1	1	1	3.60	3.60	
Power and SAR Drift Measurement	5.00	R	1.732	1	1	2.89	2.89	
Phantom and Tissue Parameters								
Phantom Uncertainty	4.00	R	1.732	1	1	2.31	2.31	
Liquid Conductivity - Target	5.00	R	1.732	0.64	0.43	1.85	1.24	
Liquid Conductivity - Meas.	8.60	N	1	0.64	0.43	5.50	3.70	
Liquid Permittivity - Target	5.00	R	1.732	0.6	0.49	1.73	1.41	
Liquid Permittivity - Meas.	3.30	N	1	0.6	0.49	1.98	1.62	
Combined Standard Uncertainty						RSS	11.44	10.49
Expanded Uncertainty (95% Confidence Interval)						K=2	22.87	20.98

Notes for table
 1. Tol. - tolerance in influence quantity
 2. N - Nomal
 3. R - Rectangular
 4. Div. - Divisor used to obtain standard uncertainty
 5. Ci - is te sensitivity coefficient

5. EQUIPMENT UNDER TEST

USB Wireless Modem, Model USB306

Network:	UMTS (W-CDMA) 850/1900 GSM850/1900
GPRS Multi-slot class:	(E)GPRS: Class 12
Antenna(s):	Internal

6. SYSTEM SPECIFICATIONS

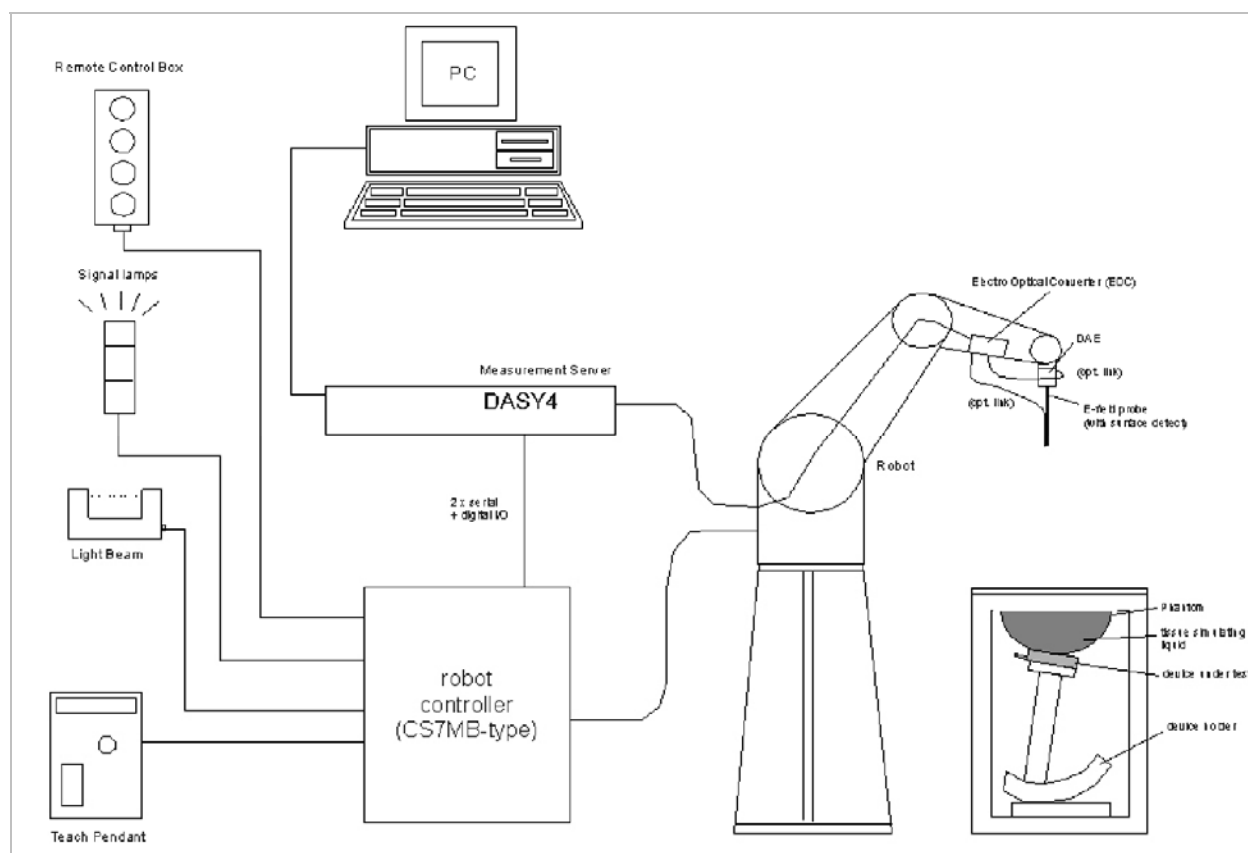

The DASY4 system for performing compliance tests consists of the following items:

- A standard high precision 6-axis robot (Stäubli RX family) with controller, teach pendant and software. An arm extension for accommodating the data acquisition electronics (DAE).
- A dosimetric probe, i.e., an isotropic E-field probe optimized and calibrated for usage in tissue simulating liquid. The probe is equipped with an optical surface detector system.
- A data acquisition electronics (DAE) which performs the signal amplification, signal multiplexing, AD-conversion, offset measurements, mechanical surface detection, collision detection, etc. The unit is battery powered with standard or rechargeable batteries. The signal is optically transmitted to the EOC.
- The function of the measurement server is to perform the time critical tasks such as signal filtering, control of the robot operation and fast movement interrupts.
- A probe alignment unit which improves the (absolute) accuracy of the probe positioning.
- A computer operating Windows 2000 or Windows XP.
- DASY4 software.
- Remote controls with teach pendant and additional circuitry for robot safety such as warning lamps, etc.
- The SAM twin phantom enabling testing left-hand and right-hand usage.
- The device holder for handheld mobile phones.
- Tissue simulating liquid mixed according to the given recipes.
- Validation dipole kits allowing to validate the proper functioning of the system.

7. COMPOSITION OF INGREDIENTS FOR TISSUE SIMULATING LIQUIDS

The following tissue formulations are provided for reference only as some of the parameters have not been thoroughly verified. The composition of ingredients may be modified accordingly to achieve the desired target tissue parameters required for routine SAR evaluation.

Ingredients (% by weight)	Frequency (MHz)									
	450		835		915		1900		2450	
Tissue Type	Head	Body	Head	Body	Head	Body	Head	Body	Head	Body
Water	38.56	51.16	41.45	52.4	41.05	56.0	54.9	40.4	62.7	73.2
Salt (NaCl)	3.95	1.49	1.45	1.4	1.35	0.76	0.18	0.5	0.5	0.04
Sugar	56.32	46.78	56.0	45.0	56.5	41.76	0.0	58.0	0.0	0.0
HEC	0.98	0.52	1.0	1.0	1.0	1.21	0.0	1.0	0.0	0.0
Bactericide	0.19	0.05	0.1	0.1	0.1	0.27	0.0	0.1	0.0	0.0
Triton X-100	0.0	0.0	0.0	0.0	0.0	0.0	0.0	0.0	36.8	0.0
DGBE	0.0	0.0	0.0	0.0	0.0	0.0	44.92	0.0	0.0	26.7
Dielectric Constant	43.42	58.0	42.54	56.1	42.0	56.8	39.9	54.0	39.8	52.5
Conductivity (S/m)	0.85	0.83	0.91	0.95	1.0	1.07	1.42	1.45	1.88	1.78

Salt: 99+% Pure Sodium Chloride

Sugar: 98+% Pure Sucrose

Water: De-ionized, 16 MΩ+ resistivity

HEC: Hydroxyethyl Cellulose

DGBE: 99+% Di(ethylene glycol) butyl ether, [2-(2-butoxyethoxy)ethanol]

Triton X-100 (ultra pure): Polyethylene glycol mono [4-(1,1, 3, 3-tetramethylbutyl)phenyl]ether

8. LIQUID PARAMETERS CHECK

The simulating liquids should be checked at the beginning of a series of SAR measurements to determine if the dielectric parameters are within the tolerances of the specified target values. The relative permittivity and conductivity of the tissue material should be within $\pm 5\%$ of the values given in the table below.

Reference Values of Tissue Dielectric Parameters for Head and Body Phantom (for 150 – 3000 MHz and 5800 MHz)

The head tissue dielectric parameters recommended by the IEEE SCC-34/SC-2 in IEEE Standard 1528 have been incorporated in the following table. These head parameters are derived from planar layer models simulating the highest expected SAR for the dielectric properties and tissue thickness variations in a human head. Other head and body tissue parameters that have not been specified in P1528 are derived from the tissue dielectric parameters computed from the 4-Cole-Cole equations and extrapolated according to the head parameters specified in IEEE Standard 1528.

Target Frequency (MHz)	Head		Body	
	ϵ_r	σ (S/m)	ϵ_r	σ (S/m)
150	52.3	0.76	61.9	0.8
300	45.3	0.87	58.2	0.92
450	43.5	0.87	56.7	0.94
835	41.5	0.9	55.2	0.97
900	41.5	0.97	55	1.05
915	41.5	0.98	55	1.06
1450	40.5	1.2	54	1.3
1610	40.3	1.29	53.8	1.4
1800 – 2000	40	1.4	53.3	1.52
2450	39.2	1.8	52.7	1.95
3000	38.5	2.4	52	2.73
5800	35.3	5.27	48.2	6

(ϵ_r = relative permittivity, σ = conductivity and $\rho = 1000 \text{ kg/m}^3$)

8.1. LIQUID CHECK RESULTS FOR 1900 MHZ

Simulating Liquid Dielectric Parameters for Muscle 1900 MHz

Room Ambient Temperature = 24°C; Relative humidity = 35% Measured by: Chaoyen Lin

f (MHz)	Muscle Liquid Parameters			Measured	Target	Delta (%)	Limit (%)
1900	e'	53.818	Relative Permittivity (ϵ_r):	53.8175	53.3	0.97	± 5
	e"	14.267	Conductivity (σ):	1.50797	1.52	-0.79	± 5

Liquid temperature: 23 deg. C

June 15, 2009 11:44 AM

Frequency	e'	e"
1710000000.	54.4669	13.7425
1720000000.	54.4411	13.8239
1730000000.	54.4444	13.9362
1740000000.	54.4512	13.9708
1750000000.	54.4555	13.9999
1760000000.	54.4003	13.9837
1770000000.	54.3490	13.9571
1780000000.	54.2855	13.9234
1790000000.	54.2039	13.9136
1800000000.	54.1295	13.9724
1810000000.	54.0748	14.0216
1820000000.	53.9792	14.1337
1830000000.	53.9239	14.2177
1840000000.	53.9049	14.3063
1850000000.	53.9135	14.3330
1860000000.	53.9012	14.3307
1870000000.	53.8965	14.3067
1880000000.	53.8989	14.2651
1890000000.	53.8516	14.2479
1900000000.	53.8175	14.2666
1910000000.	53.7310	14.3721

The conductivity (σ) can be given as:

$$\sigma = \omega \epsilon_0 e'' = 2 \pi f \epsilon_0 e''$$

where $f = \text{target } f * 10^6$

$$\epsilon_0 = 8.854 * 10^{-12}$$

Simulating Liquid Dielectric Parameters for Muscle 1900 MHz

Room Ambient Temperature = 24°C; Relative humidity = 40% Measured by: Sunny Shih

f (MHz)	Muscle Liquid Parameters			Measured	Target	Delta (%)	Limit (%)
1900	e'	53.187	Relative Permittivity (ϵ_r):	53.1870	53.3	-0.21	± 5
	e"	14.575	Conductivity (σ):	1.54053	1.52	1.35	± 5

Liquid temperature: 23 deg. C
 June 16, 2009 09:37 AM

Frequency	e'	e"
1710000000.	53.9517	13.9266
1720000000.	53.9352	13.9732
1730000000.	53.9220	14.0651
1740000000.	53.9073	14.1432
1750000000.	53.8876	14.2035
1760000000.	53.8156	14.2344
1770000000.	53.7392	14.2402
1780000000.	53.6833	14.2290
1790000000.	53.6302	14.2234
1800000000.	53.5762	14.2485
1810000000.	53.5197	14.2726
1820000000.	53.4575	14.3170
1830000000.	53.4414	14.3612
1840000000.	53.4118	14.4618
1850000000.	53.3882	14.5497
1860000000.	53.3141	14.5991
1870000000.	53.2517	14.5983
1880000000.	53.2302	14.5681
1890000000.	53.2030	14.5582
1900000000.	53.1870	14.5746
1910000000.	53.1400	14.5873

The conductivity (σ) can be given as:

$$\sigma = \omega \epsilon_0 e'' = 2 \pi f \epsilon_0 e''$$

where $f = \text{target } f * 10^6$

$$\epsilon_0 = 8.854 * 10^{-12}$$

Simulating Liquid Dielectric Parameters for Muscle 1900 MHz

Room Ambient Temperature = 24°C; Relative humidity = 40% Measured by: Chaoyen Lin

f (MHz)	Muscle Liquid Parameters			Measured	Target	Delta (%)	Limit (%)
1900	e'	53.755	Relative Permittivity (ϵ_r):	53.7545	53.3	0.85	± 5
	e''	14.035	Conductivity (σ):	1.48352	1.52	-2.40	± 5

Liquid temperature: 23 deg. C
 June 17, 2009 04:34 PM

Frequency	e'	e''
1710000000.	54.3564	13.5044
1720000000.	54.3457	13.5699
1730000000.	54.3445	13.6568
1740000000.	54.3412	13.7379
1750000000.	54.3408	13.7717
1760000000.	54.2843	13.7725
1770000000.	54.2490	13.7404
1780000000.	54.1877	13.7021
1790000000.	54.1289	13.7028
1800000000.	54.0654	13.7377
1810000000.	53.9925	13.7925
1820000000.	53.9249	13.8507
1830000000.	53.8724	13.9473
1840000000.	53.8681	14.0373
1850000000.	53.8441	14.0866
1860000000.	53.8166	14.1135
1870000000.	53.8015	14.0997
1880000000.	53.8018	14.0534
1890000000.	53.7753	14.0285
1900000000.	53.7545	14.0353
1910000000.	53.6753	14.0718

The conductivity (σ) can be given as:

$$\sigma = \omega \epsilon_0 e'' = 2 \pi f \epsilon_0 e''$$

where $f = \text{target } f * 10^6$

$$\epsilon_0 = 8.854 * 10^{-12}$$

8.2. LIQUID CHECK RESULTS FOR 835 MHZ

Simulating Liquid Dielectric Parameters for Muscle 835 MHz

Room Ambient Temperature = 24°C; Relative humidity = 40%

Measured by: Chaoyen Lin

f (MHz)	Liquid Parameters			Measured	Target	Delta (%)	Limit (%)
835	e'	53.01	Relative Permittivity (ϵ_r):	53.006	55.2	-3.97	± 5
	e''	20.89	Conductivity (σ):	0.970	0.97	0.04	± 5

Liquid temperature: 23 deg. C

June 17, 2009 10:04 PM

Frequency	e'	e''
800000000.	53.4377	21.1333
805000000.	53.3594	21.1160
810000000.	53.2888	21.0683
815000000.	53.2231	21.0475
820000000.	53.1667	21.0182
825000000.	53.1560	20.9897
830000000.	53.0879	20.9376
835000000.	53.0063	20.8910
840000000.	52.9794	20.9019
845000000.	52.9490	20.8704
850000000.	52.9228	20.8483
855000000.	52.8359	20.8055
860000000.	52.7736	20.7973
865000000.	52.7337	20.7596
870000000.	52.6502	20.7173
875000000.	52.6133	20.7112
880000000.	52.5667	20.6771
885000000.	52.5257	20.6833
890000000.	52.4787	20.6708
895000000.	52.4599	20.6478
900000000.	52.4163	20.6395
905000000.	52.3469	20.6155
910000000.	52.2648	20.6225
915000000.	52.1692	20.6042
920000000.	52.1103	20.5722
925000000.	52.0339	20.5322
930000000.	52.0260	20.4963
935000000.	51.9611	20.4426
940000000.	51.9040	20.4066

The conductivity (σ) can be given as:

$$\sigma = \omega \epsilon_0 e'' = 2 \pi f \epsilon_0 e''$$

where $f = \text{target } f * 10^6$

$$\epsilon_0 = 8.854 * 10^{-12}$$

Simulating Liquid Dielectric Parameters for Muscle 835 MHz

Room Ambient Temperature = 24°C; Relative humidity = 40%

Measured by: Chaoyen Lin

f (MHz)	Liquid Parameters			Measured	Target	Delta (%)	Limit (%)
835	e'	53.58	Relative Permittivity (ϵ_r):	53.576	55.2	-2.94	± 5
	e''	20.92	Conductivity (σ):	0.972	0.97	0.17	± 5

Liquid temperature: 23 deg. C
 June 19, 2009 09:10 AM

Frequency	e'	e''
800000000.	54.0514	21.1012
805000000.	53.9562	21.0766
810000000.	53.8908	21.0365
815000000.	53.8237	21.0199
820000000.	53.7634	20.9566
825000000.	53.7168	20.9445
830000000.	53.6438	20.9477
835000000.	53.5760	20.9162
840000000.	53.5094	20.8847
845000000.	53.4763	20.8523
850000000.	53.4449	20.8521
855000000.	53.3874	20.8075
860000000.	53.3508	20.7879
865000000.	53.3279	20.7740
870000000.	53.2859	20.7353
875000000.	53.2588	20.7339
880000000.	53.2382	20.7193
885000000.	53.2069	20.7299
890000000.	53.1842	20.7056
895000000.	53.1475	20.6973
900000000.	53.1297	20.6817
905000000.	53.0705	20.6512
910000000.	53.0148	20.6403
915000000.	52.9273	20.6114
920000000.	52.8960	20.5659
925000000.	52.8476	20.5276
930000000.	52.8044	20.4621
935000000.	52.7324	20.4494
940000000.	52.6874	20.4261
945000000.	52.6554	20.4078
950000000.	52.6326	20.3859

The conductivity (σ) can be given as:

$$\sigma = \omega \epsilon_0 e'' = 2 \pi f \epsilon_0 e''$$

where $f = \text{target } f * 10^6$

$$\epsilon_0 = 8.854 * 10^{-12}$$

9. SYSTEM CHECK

The system performance check is performed prior to any usage of the system in order to guarantee reproducible results. The system performance check verifies that the system operates within its specifications of $\pm 10\%$.

System Performance Check Measurement Conditions

- The measurements were performed in the flat section of the SAM twin phantom filled with Head or Body simulating liquid of the following parameters.
- The DASY4 system with an Isotropic E-Field Probe EX3DV3 was used for the measurements.
- The dipole was mounted on the small tripod so that the dipole feed point was positioned below the center marking of the flat phantom section and the dipole was oriented parallel to the body axis (the long side of the phantom). The standard measuring distance was 10 mm (above 1 GHz) and 15 mm (below 1 GHz) from dipole center to the simulating liquid surface.
- The coarse grid with a grid spacing of 15 mm was aligned with the dipole.
For 5 GHz band - The coarse grid with a grid spacing of 10 mm was aligned with the dipole.
- Special 7x7x7 fine cube was chosen for cube
- Distance between probe sensors and phantom surface was set to 3 mm.
For 5 GHz band - Distance between probe sensors and phantom surface was set to 2.5 mm
- The dipole input power (forward power) was $250 \text{ mW} \pm 3\%$.
- The results are normalized to 1 W input power.

450 to 2450 MHz Reference SAR Values for Body-tissue (From SPEAG)

Dipole Type	Distance	Frequency	SAR (1g)	SAR (10g)	SAR (peak)
	(mm)	(MHz)	[W/kg]	[W/kg]	[W/kg]
D450V2	15	450	5.01	3.36	7.22
D835V2	15	835	9.71	6.38	14.1
D900V2	15	900	11.1	7.17	16.3
D1450V2	10	1450	29.6	16.6	49.8
D1800V2	10	1800	38.5	20.3	67.5
D1900V2	10	1900	39.8	20.8	69.6
D2000V2	10	2000	40.9	21.2	71.5
D2450V2	10	2450	51.2	23.7	97.6

Note: All SAR values normalized to 1 W forward power.

9.1. SYSTEM CHECK RESULTS FOR D1900V2

System Validation Dipole: D1900V2 SN: 5d043

Date: June 15, 2009

Ambient Temperature = 24°C; Relative humidity = 40%

Measured by: Chaoyen Lin

Medium	CW Signal (MHz)	Forward power (mW)	Measured (Normalized to 1 W)		Target	Delta (%)	Tolerance (%)
Body	1900	250	1g SAR:	40.3	39.8	1.26	±10
			10g SAR:	21.0	20.8	0.96	

Date: June 16, 2009

Ambient Temperature = 24°C; Relative humidity = 40%

Measured by: Sunny Shih

Medium	CW Signal (MHz)	Forward power (mW)	Measured (Normalized to 1 W)		Target	Delta (%)	Tolerance (%)
Body	1900	250	1g SAR:	38.3	39.8	-3.77	±10
			10g SAR:	19.9	20.8	-4.33	

Date: June 17, 2009

Ambient Temperature = 24°C; Relative humidity = 40%

Measured by: Chaoyen Lin

Medium	CW Signal (MHz)	Forward power (mW)	Measured (Normalized to 1 W)		Target	Delta (%)	Tolerance (%)
Body	1900	250	1g SAR:	37.6	39.8	-5.53	±10
			10g SAR:	19.8	20.8	-4.81	

9.2. SYSTEM CHECK RESULTS FOR D835V2

System Validation Dipole: D835V2 SN:4d002

Date: June 17, 2009

Ambient Temperature = 24°C; Relative humidity = 40%

Measured by: Chaoyen Lin

Medium	CW Signal (MHz)	Forward power (mW)	Measured (Normalized to 1 W)		Target	Delta (%)	Tolerance (%)
Body	835	250	1g SAR:	9.67	9.71	-0.41	±10
			10g SAR:	6.35	6.38	-0.47	

Date: June 19, 2009

Ambient Temperature = 25°C; Relative humidity = 40%

Measured by: Chaoyen Lin

Medium	CW Signal (MHz)	Forward power (mW)	Measured (Normalized to 1 W)		Target	Delta (%)	Tolerance (%)
Body	835	250	1g SAR:	10.2	9.71	5.05	±10
			10g SAR:	6.68	6.38	4.70	

10. OUTPUT POWER VERIFICATION

10.1. GSM

GPRS (GMSK) - Coding Scheme: MCS4

Band	Ch No.	f (MHz)	Conducted output power (dBm)							
			1 slot	Time Average power	2 slot	Time Average power	3 slot	Time Average power	4 slot	Time Average power
GSM850	128	824.2	31.80	22.80	29.10	23.10	27.20	22.94	25.80	22.80
	190	836.6	31.60	22.60	28.60	22.60	27.10	22.84	25.90	22.90
	251	848.8	31.80	22.80	28.90	22.90	27.00	22.74	25.70	22.70
GSM1900	512	1850.2	29.30	20.30	25.90	19.90	24.20	19.94	23.10	20.10
	661	1880	28.90	19.90	26.10	20.10	24.20	19.94	23.00	20.00
	810	1909.8	28.90	19.90	25.70	19.70	24.00	19.74	22.80	19.80

EGPRS (8PSK) - Coding Scheme: MCS9

Band	Ch No.	f (MHz)	Conducted output power (dBm)							
			1 slot	Time Average power	2 slot	Time Average power	3 slot	Time Average power	4 slot	Time Average power
GSM850	128	824.2	27.10	18.10	27.10	21.10	27.00	22.74	25.70	22.70
	190	836.6	26.80	17.80	27.20	21.20	27.10	22.84	25.80	22.80
	251	848.8	27.00	18.00	27.10	21.10	27.00	22.74	25.60	22.60
GSM1900	512	1850.2	26.10	17.10	26.00	20.00	23.20	18.94	22.10	19.10
	661	1880	26.10	17.10	26.10	20.10	23.00	18.74	22.20	19.20
	810	1909.8	26.20	17.20	26.10	20.10	23.00	18.74	22.10	19.10

10.2. UMTS RELEASE 99

The following tests were completed according to the test requirements outlined in section 5.2 of the 3GPP TS34.121-1 V7.5.0 specification. The EUT supports power Class 3, which has a nominal maximum output power of 24 dBm (+1.7/-3.7). A summary of these settings are illustrated below:

	Mode	Rel99
	Subtest	-
WCDMA General Settings	Loopback Mode	Test Mode 1
	Rel99 RMC	12.2kbps RMC
	HSDPA FRC	Not Applicable
	HSUPA Test	Not Applicable
	Power Control Algorithm	Algorithm2
	β_c	Not Applicable
	β_d	Not Applicable
	β_{ec}	Not Applicable
	β_c/β_d	8/15
	β_{hs}	Not Applicable
	β_{ed}	Not Applicable

Results

Rel 99 (12.2kps RMC)

Band	Mode	UL Ch No.	DL Ch No.	f (MHz)	O/P Power (dBm)
UMTS850 (Band V)	Rel 99 12.2kps RMC	4132	4357	826.4	22.71
		4182	4407	836.4	22.78
		4233	4458	846.6	22.82
UMTS1900 (Band II)	Rel 99 12.2kps RMC	9262	9662	1852.4	21.68
		9400	9800	1880.0	21.78
		9538	9938	1907.6	21.78

10.3. UMTS HSDPA

The following 4 Sub-tests were completed according to Release 5 procedures in section 5.2 of 3GPP TS34.121. A summary of these settings are illustrated below:

	Mode	Rel6 HSDPA	Rel6 HSDPA	Rel6 HSDPA	Rel6 HSDPA
	Subtest	1	2	3	4
WCDMA General Settings	Loopback Mode	Test Mode 1			
	Rel99 RMC	12.2kbps RMC			
	HSDPA FRC	H-Set1			
	HSUPA Test	Not Applicable			
	Power Control Algorithm	Algorithm 2			
	β_c	2/15	12/15	15/15	15/15
	β_d	15/15	15/15	8/15	4/15
	Bd (SF)	64			
	β_{ec}	-	-	-	-
	β_c/β_d	2/15	12/15	15/8	15/4
	β_{hs}	4/15	24/15	30/15	30/15
	β_{ed}	Not Applicable			
CM (dB)	0	1	1.5	1.5	
MPR (dB)	0	0	0.5	0.5	
HSDPA Specific Settings	DACK	8			
	DNAK	8			
	DCQI	8			
	Ack-Nack repetition factor	3			
	CQI Feedback (Table 5.2B.4)	4ms			
	CQI Repetition Factor (Table 5.2B.4)	2			
	Ahs = β_{hs}/β_c	30/15			

Results

Rel 6 HSDPA

Band	Mode	UL Ch No.	DL Ch No.	f (MHz)	O/P Power (dBm)
UMTS850 (Band V)	Subtest 1	4132	4357	826.4	22.65
		4182	4407	836.4	22.68
		4233	4458	846.6	22.80
	Subtest 2	4132	4357	826.4	22.50
		4182	4407	836.4	22.52
		4233	4458	846.6	22.65
	Subtest 3	4132	4357	826.4	21.88
		4182	4407	836.4	21.91
		4233	4458	846.6	22.03
	Subtest 4	4132	4357	826.4	21.80
		4182	4407	836.4	21.89
		4233	4458	846.6	22.00
UMTS1900 (Band II)	Subtest 1	9262	9662	1852.4	21.42
		9400	9800	1880.0	21.30
		9538	9938	1907.6	21.15
	Subtest 2	9262	9662	1852.4	21.63
		9400	9800	1880.0	21.48
		9538	9938	1907.6	21.41
	Subtest 3	9262	9662	1852.4	20.61
		9400	9800	1880.0	20.48
		9538	9938	1907.6	20.34
	Subtest 4	9262	9662	1852.4	20.56
		9400	9800	1880.0	20.43
		9538	9938	1907.6	20.31

10.4. UMTS Rel 6 HSPA (HSDPA & HSUPA)

The following 5 Sub-tests were completed according to Release 6 procedures in section 5.2 of 3GPP TS34.121. A summary of these settings are illustrated below:

Mode	Rel6 HSPA	Rel6 HSPA	Rel6 HSPA	Rel6 HSPA	Rel6 HSPA	
Subtest	1	2	3	4	5	
WCDMA General Settings	Loopback Mode					
	Test Mode 1					
	Rel99 RMC					
	12.2kbps RMC					
	HSDPA FRC					
	H-Set1					
	HSUPA Test					
	HSUPA Loopback					
	Power Control Algorithm					
	Algorithm2					
	β_c	11/15	6/15	15/15	2/15	15/15
	β_d	15/15	15/15	9/15	15/15	15/15
β_{ec}	209/225	12/15	30/15	2/15	24/15	
β_c/β_d	11/15	6/15	15/9	2/15	15/15	
β_{hs}	22/15	12/15	30/15	4/15	30/15	
β_{ed}	1309/225	94/75	47/15	56/75	134/15	
CM (dB)	1.0	3.0	2.0	3.0	1.0	
MPR (dB)	0	2	1	2	0	
HSDPA Specific Settings	DACK					
	8					
	DNAK					
	8					
	DCQI					
	8					
	Ack-Nack repetition factor					
3						
CQI Feedback (Table 5.2B.4)						
4ms						
CQI Repetition Factor (Table 5.2B.4)						
2						
Ahs = β_{hs}/β_c						
30/15						
HSUPA Specific Settings	D E-DPCCH					
	6					
	8					
	8					
	5					
	7					
	DHARQ					
	0					
	0					
	0					
AG Index						
20						
12						
15						
17						
21						
ETFCI (from 34.121 Table C.11.1.3)						
75						
67						
92						
71						
81						
Associated Max UL Data Rate kbps						
242.1						
174.9						
482.8						
205.8						
308.9						
Reference E_TFCIs						
E-TFCI 11						
E-TFCI PO 4						
E-TFCI 67						
E-TFCI PO 18						
E-TFCI 71						
E-TFCI PO 23						
E-TFCI 75						
E-TFCI PO 26						
E-TFCI 81						
E-TFCI PO 27						
E-TFCI 11						
E-TFCI PO 4						
E-TFCI 92						
E-TFCI PO 18						
E-TFCI 11						
E-TFCI PO 4						
E-TFCI 67						
E-TFCI PO 18						
E-TFCI 71						
E-TFCI PO 23						
E-TFCI 75						
E-TFCI PO 26						
E-TFCI 81						
E-TFCI PO 27						

Results

Rel 6 HSPA

Band	Mode	UL Ch No.	DL Ch No.	f (MHz)	O/P Power (dBm)
UMTS850 (Band V)	Subtest 1	4132	4357	826.4	21.63
		4182	4407	836.4	21.17
		4233	4458	846.6	22.25
	Subtest 2	4132	4357	826.4	20.88
		4182	4407	836.4	20.85
		4233	4458	846.6	21.37
	Subtest 3	4132	4357	826.4	21.53
		4182	4407	836.4	21.28
		4233	4458	846.6	21.31
	Subtest 4	4132	4357	826.4	20.67
		4182	4407	836.4	20.73
		4233	4458	846.6	20.83
	Subtest 5	4132	4357	826.4	22.40
		4182	4407	836.4	22.35
		4233	4458	846.6	22.39
UMTS1900 (Band II)	Subtest 1	9262	9662	1852.4	20.76
		9400	9800	1880.0	20.65
		9538	9938	1907.6	20.49
	Subtest 2	9262	9662	1852.4	20.70
		9400	9800	1880.0	20.56
		9538	9938	1907.6	20.40
	Subtest 3	9262	9662	1852.4	20.07
		9400	9800	1880.0	20.60
		9538	9938	1907.6	20.40
	Subtest 4	9262	9662	1852.4	20.03
		9400	9800	1880.0	20.63
		9538	9938	1907.6	20.12
	Subtest 5	9262	9662	1852.4	21.23
		9400	9800	1880.0	21.10
		9538	9938	1907.6	20.86

Note: In HSUPA operation, the output power is reduced relative to the tuning target power for WCDMA. This device implements the following MPR for each of the Subtest modes:

Maximum Power Reduction (MPR)				
Subtest mode 1	Subtest mode 2	Subtest mode 3	Subtest mode 4	Subtest mode 5
1.0 dB	1.5 dB	1.5 dB	2.0 dB	0.5 dB

The HSUPA power never goes above Release 99 power, and all the transmitting power levels are within the ranges specified by the 3GPP standards.

11. SUMMARY OF TEST RESULTS

If the SAR measured at the middle channel for each test configuration is at least 3.0 dB (0.8 mW/g) lower than the SAR limit (1.6 mW/g), testing at the high and low channels is optional for such test configuration(s).

11.1. UMTS BAND II (1900 MHZ)

11.1.1. Horizontal Up

Sep. dist. (mm)	Mode	UL Ch No.	DL Ch No.	f (MHz)	1g SAR (mW/g)	Limit (mW/g)
5	R99	9262	9662	1852.4	1.50	1.6
		9400	9800	1880.0	1.24	
		9538	9938	1907.6	1.30	

11.1.2. Horizontal Down

Sep. dist. (mm)	Mode	UL Ch No.	DL Ch No.	f (MHz)	1g SAR (mW/g)	Limit (mW/g)
5	R99	9262	9662	1852.4		1.6
		9400	9800	1880.0	0.496	
		9538	9938	1907.6		

11.1.3. Vertical Front

Sep. dist. (mm)	Mode	UL Ch No.	DL Ch No.	f (MHz)	1g SAR (mW/g)	Limit (mW/g)
5	R99	9262	9662	1852.4		1.6
		9400	9800	1880.0	0.535	
		9538	9938	1907.6		

11.1.4. Vertical Back

Sep. dist. (mm)	Mode	UL Ch No.	DL Ch No.	f (MHz)	1g SAR (mW/g)	Limit (mW/g)
5	R99	9262	9662	1852.4		1.6
		9400	9800	1880.0	0.336	
		9538	9938	1907.6		

11.2. GSM1900

11.2.1. Horizontal Up

Sep. dist. (mm)	Mode	Ch No.	f (MHz)	1g SAR (mW/g)	Limit (mW/g)
5	GPRS 4 slots	512	1850.2	1.220	1.6
		661	1880.0	1.270	
		810	1909.8	1.430	

11.2.2. Horizontal Down

Sep. dist. (mm)	Mode	Ch No.	f (MHz)	1g SAR (mW/g)	Limit (mW/g)
5	GPRS 4 slots	512	1850.2		1.6
		661	1880.0	0.608	
		810	1909.8		

11.2.3. Vertical Front

Sep. dist. (mm)	Mode	Ch No.	f (MHz)	1g SAR (mW/g)	Limit (mW/g)
5	GPRS 4 slots	512	1850.2	0.599	1.6
		661	1880.0	0.528	
		810	1909.8	0.610	

11.2.4. Vertical Back

Sep. dist. (mm)	Mode	Ch No.	f (MHz)	1g SAR (mW/g)	Limit (mW/g)
5	GPRS 4 slots	512	1850.2		1.6
		661	1880.0	0.454	
		810	1909.8		

11.3. UMTS BAND V (850 MHZ)

11.3.1. Horizontal Up

Sep. dist. (mm)	Mode	UL Ch No.	DL Ch No.	f (MHz)	1g SAR (mW/g)	Limit (mW/g)
5	R99 12.2kps RMC	4132	4357	826.4		1.6
		4182	4407	836.4	0.691	
		4233	4458	846.6		

11.3.2. Horizontal Down

Sep. dist. (mm)	Mode	UL Ch No.	DL Ch No.	f (MHz)	1g SAR (mW/g)	Limit (mW/g)
5	R99 12.2kps RMC	4132	4357	826.4	0.694	1.6
		4182	4407	836.4	0.836	
		4233	4458	846.6	0.733	

11.3.3. Vertical Front

Sep. dist. (mm)	Mode	UL Ch No.	DL Ch No.	f (MHz)	1g SAR (mW/g)	Limit (mW/g)
5	R99 12.2kps RMC	4132	4357	826.4		1.6
		4182	4407	836.4	0.531	
		4233	4458	846.6		

11.3.4. Vertical Back

Sep. dist. (mm)	Mode	UL Ch No.	DL Ch No.	f (MHz)	1g SAR (mW/g)	Limit (mW/g)
5	R99 12.2kps RMC	4132	4357	826.4		1.6
		4182	4407	836.4	0.360	
		4233	4458	846.6		

11.4. GSM850

11.4.1. Horizontal Up

Sep. dist. (mm)	Mode	Ch No.	f (MHz)	1g SAR (mW/g)	Limit (mW/g)
5	GPRS 4 slots	128	824.2		1.6
		190	836.6	0.672	
		251	848.8		

11.4.2. Horizontal Down

Sep. dist. (mm)	Mode	Ch No.	f (MHz)	1g SAR (mW/g)	Limit (mW/g)
5	GPRS 4 slots	128	824.2		1.6
		190	836.6	0.754	
		251	848.8		

11.4.3. Vertical Front

Sep. dist. (mm)	Mode	Ch No.	f (MHz)	1g SAR (mW/g)	Limit (mW/g)
5	GPRS 4 slots	128	824.2		1.6
		190	836.6	0.728	
		251	848.8		

11.4.4. Vertical Back

Sep. dist. (mm)	Mode	Ch No.	f (MHz)	1g SAR (mW/g)	Limit (mW/g)
5	GPRS 4 slots	128	824.2		1.6
		190	836.6	0.492	
		251	848.8		

12. WORST-CASE SAR TEST PLOTS

WORST-CASE SAR PLOT for Part 22H - BODY POSITION

Date/Time: 6/18/2009 12:02:23 AM

Test Laboratory: Compliance Certification Services

Band V - Horizontal Down

DUT: Sierra Wireless; Type: USB306; Serial: n/a

Communication System: UMTS850; Frequency: 836.4 MHz; Duty Cycle: 1:1
Medium parameters used (interpolated): $f = 836.4$ MHz; $\sigma = 0.972$ mho/m; $\epsilon_r = 53$; $\rho = 1000$ kg/m³
Phantom section: Flat Section

Room Ambient Temperature: 24.0 deg. C; Liquid Temperature: 23.0 deg. C

DASY4 Configuration:

- Area Scan setting - Find Secondary Maximum Within: 2.0 dB and with a peak SAR value greater than 0.0012W/kg
- Probe: EX3DV4 - SN3686; ConvF(8.7, 8.7, 8.7); Calibrated: 3/23/2009
- Sensor-Surface: 3mm (Mechanical Surface Detection)
- Electronics: DAE3 Sn427; Calibrated: 10/20/2008
- Phantom: Flat Phantom ELI4.0; Type: QDOVA001BA; Serial: SN:XXXX
- Measurement SW: DASY4, V4.7 Build 80; Postprocessing SW: SEMCAD, V1.8 Build 186

M-ch_Band V R99 2/Area Scan (6x8x1): Measurement grid: dx=15mm, dy=15mm

[Info: Interpolated medium parameters used for SAR evaluation.](#)

Maximum value of SAR (measured) = 0.876 mW/g

M-ch_Band V R99 2/Zoom Scan (7x7x9)/Cube 0: Measurement grid: dx=5mm, dy=5mm, dz=3mm

Reference Value = 16.1 V/m; Power Drift = -21.1 dB

Peak SAR (extrapolated) = 2.01 W/kg

SAR(1 g) = 0.836 mW/g; SAR(10 g) = 0.529 mW/g

[Info: Interpolated medium parameters used for SAR evaluation.](#)

Maximum value of SAR (measured) = 0.933 mW/g

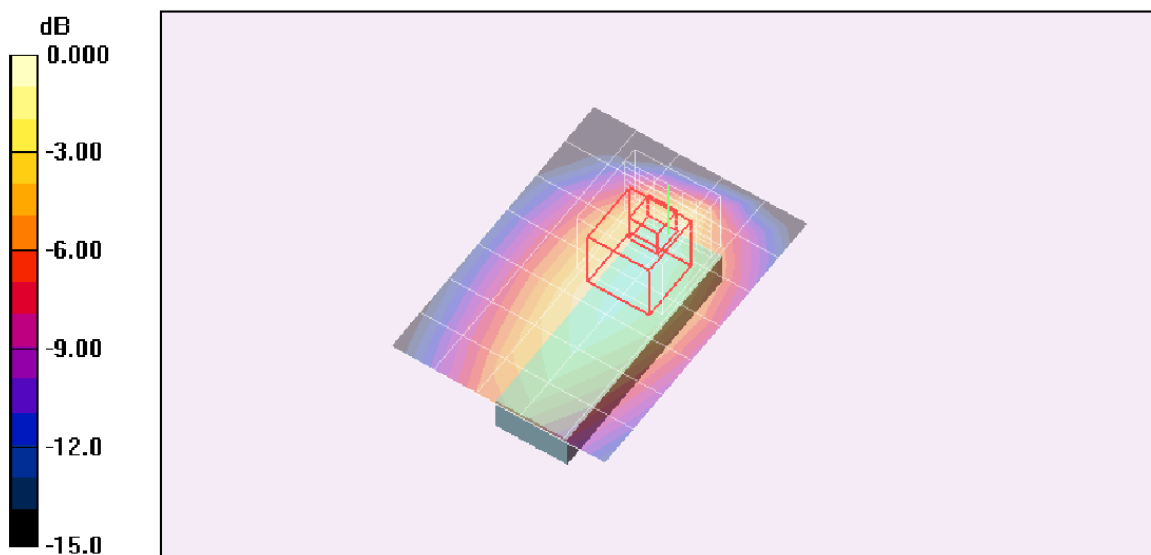

WORST-CASE SAR PLOT for Part 24E- BODY POSITION

Date/Time: 6/15/2009 1:49:22 PM

Test Laboratory: Compliance Certification Services

Band II - Horizontal Up

DUT: Sierra Wireless; Type: USB306; Serial: n/a

Communication System: PCS 1900; Frequency: 1852.4 MHz; Duty Cycle: 1:1
Medium parameters used (interpolated): $f = 1852.4$ MHz; $\sigma = 1.48$ mho/m; $\epsilon_r = 53.9$; $\rho = 1000$ kg/m³
Phantom section: Flat Section

Room Ambient Temperature: 24.0 deg. C; Liquid Temperature: 23.0 deg. C

DASY4 Configuration:

- Area Scan setting - Find Secondary Maximum Within: 2.0 dB and with a peak SAR value greater than 0.0012W/kg
- Probe: EX3DV4 - SN3686; ConvF(6.85, 6.85, 6.85); Calibrated: 3/23/2009
- Sensor-Surface: 3mm (Mechanical Surface Detection)
- Electronics: DAE3 Sn427; Calibrated: 10/20/2008
- Phantom: Flat Phantom ELI4.0; Type: QDOVA001BA; Serial: SN:XXXX
- Measurement SW: DASY4, V4.7 Build 80; Postprocessing SW: SEMCAD, V1.8 Build 186

L-ch_Band II R99/Area Scan (6x8x1): Measurement grid: dx=15mm, dy=15mm

Info: [Interpolated medium parameters used for SAR evaluation.](#)

Maximum value of SAR (measured) = 1.60 mW/g

L-ch_Band II R99/Zoom Scan (7x7x9)/Cube 0: Measurement grid: dx=5mm, dy=5mm, dz=3mm

Reference Value = 10.2 V/m; Power Drift = 1.07 dB

Peak SAR (extrapolated) = 2.83 W/kg

SAR(1 g) = 1.5 mW/g; SAR(10 g) = 0.768 mW/g

Info: [Interpolated medium parameters used for SAR evaluation.](#)

Maximum value of SAR (measured) = 1.91 mW/g

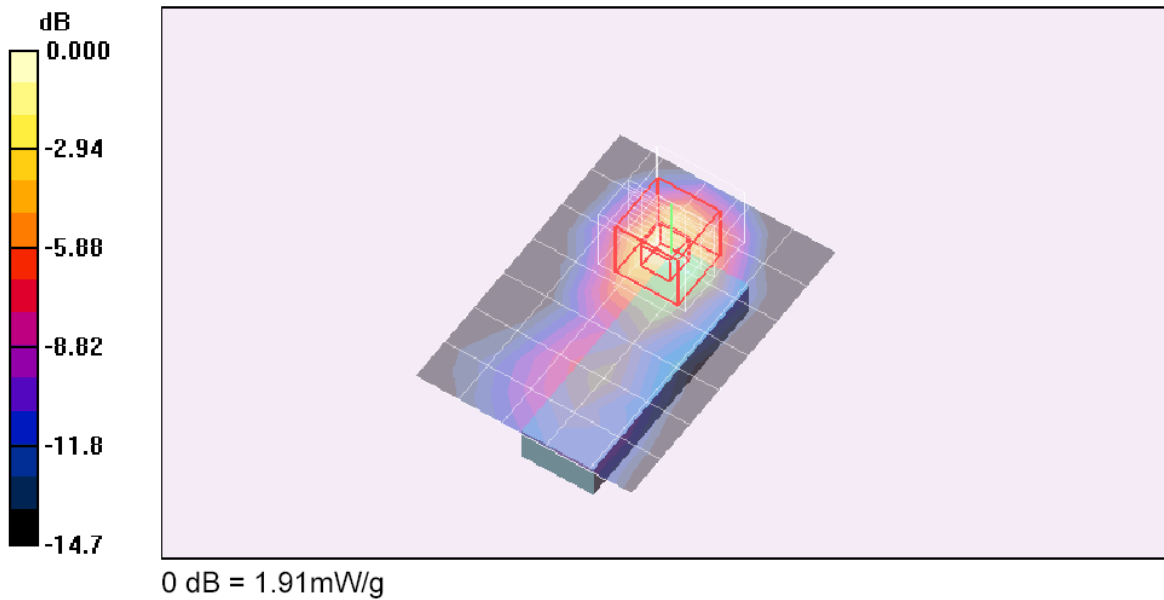

13. ATTACHMENTS

No.	Contents	No. of page (s)
1	System Performance Check Plots	10
2-1	SAR Test Plots for UMTS1900	7
2-2	SAR Test Plots for GSM1900	10
2-3	SAR Test Plots for UMTS850	7
2-4	SAR Test Plots for GSM850	4
3	Certificate of E-Field Probe – EX3DV4 SN3686	10
4	Certificate of System Validation Dipole - D835V2 SN:4d002	9
5	Certificate of System Validation Dipole - D1900V2 SN:5d043	9