



**FCC OET BULLETIN 65 SUPPLEMENT C
IC RSS-102 ISSUE 2**

SAR EVALUATION REPORT

For

USB WIRELESS MODEM

MODEL: USB305

FCC ID: N7NU305

IC: 2417C-U305

REPORT NUMBER: 09U12572-1, Revision C

ISSUE DATE: September 17, 2009

Prepared for

**SIERRA WIRELESS, INC
13811 WIRELESS WAY
RICHMOND, BC V6V 3A4 CANADA**

Prepared by

**COMPLIANCE CERTIFICATION SERVICES
47173 BENICIA STREET
FREMONT, CA 94538, U.S.A.
TEL: (510) 771-1000
FAX: (510) 661-0888**



NVLAP LAB CODE 200065-0

Revision History

| Rev. | Issue Date | Revisions | Revised By |
|------|---------------|--|------------|
| -- | June 15, 2009 | Initial Issue | -- |
| A | 06/17/09 | Revised FCC ID | A. Zaffar |
| B | 9/16/09 | Updated Conducted RF power table in Section 10.4 | Sunny Shih |
| C | 9/17/09 | Added note in Section 10.4 page 22 of 32 | Sunny Shih |

TABLE OF CONTENTS

- 1. ATTESTATION OF TEST RESULTS..... 5**
- 2. TEST METHODOLOGY 6**
- 3. FACILITIES AND ACCREDITATION..... 6**
- 4. CALIBRATION AND UNCERTAINTY..... 7**
 - 4.1. *MEASURING INSTRUMENT CALIBRATION..... 7*
 - 4.2. *MEASUREMENT UNCERTAINTY..... 8*
- 5. EQUIPMENT UNDER TEST 9**
- 6. SYSTEM SPECIFICATIONS 10**
- 7. COMPOSITION OF INGREDIENTS FOR TISSUE SIMULATING LIQUIDS 11**
- 8. LIQUID PARAMETERS CHECK..... 12**
 - 8.1. *LIQUID CHECK RESULTS FOR 1900 MHZ..... 13*
 - 8.2. *LIQUID CHECK RESULTS FOR 835 MHZ..... 15*
- 9. SYSTEM CHECK 16**
 - 9.1. *SYSTEM CHECK RESULTS FOR D1900V2..... 17*
 - 9.2. *SYSTEM CHECK RESULTS FOR D835V2..... 17*
- 10. OUTPUT POWER VERIFICATION..... 18**
 - 10.1. *GSM..... 18*
 - 10.2. *UMTS RELEASE 99..... 19*
 - 10.3. *UMTS HSDPA..... 20*
 - 10.4. *UMTS Rel 6 HSPA (HSDPA & HSUPA) 21*
- 11. SUMMARY OF TEST RESULTS..... 23**
 - 11.1. *UMTS BAND II (1900 MHZ)..... 23*
 - 11.1.1. *TEST POSITION 1 (FRONT) 23*
 - 11.1.2. *TEST POSITION 2 (BACK)..... 23*
 - 11.1.3. *TEST POSITION 3 (SIDE) 23*
 - 11.1.4. *TEST POSITION 4 (SIDE) 23*
 - 11.1.5. *TEST POSITION 5 (TIP) 23*
 - 11.2. *GSM1900..... 24*
 - 11.2.1. *TEST POSITION 1 (FRONT) 24*
 - 11.2.2. *TEST POSITION 2 (BACK)..... 24*
 - 11.2.3. *TEST POSITION 3 (SIDE) 24*
 - 11.2.4. *TEST POSITION 4 (SIDE) 24*
 - 11.2.5. *TEST POSITION 5 (TIP) 24*

11.3. UMTS BAND V (850 MHZ)..... 25

11.3.1. TEST POSITION 125

11.3.2. TEST POSITION 225

11.3.3. TEST POSITION 3 (SIDE)25

11.3.4. TEST POSITION 4 (SIDE)25

11.3.5. TEST POSITION 5 (TIP)25

11.4. GSM850..... 26

11.4.1. TEST POSITION 126

11.4.2. TEST POSITION 226

11.4.3. TEST POSITION 3 (SIDE)26

11.4.4. TEST POSITION 4 (SIDE)26

11.4.5. TEST POSITION 5 (SIDE)26

12. WORST-CASE SAR TEST PLOTS27

13. ATTACHMENTS29

14. TEST SETUP PHOTO30

1. ATTESTATION OF TEST RESULTS

COMPANY NAME: SIERRA WIRELESS, INC
 13811 WIRELESS WAY
 RICHMOND, BC V6V 3A4 CANADA

EUT DESCRIPTION: USB wireless modem

MODEL NUMBER: USB305

DEVICE CATEGORY: Portable

EXPOSURE CATEGORY: General Population/Uncontrolled Exposure

DATE TESTED: May 23 – 26, 2009

THE HIGHEST SAR VALUES:

| FCC / IC Rule Parts | Frequency Range [MHz] | The Highest SAR Values (1g_mW/g) | Limit (mW/g) |
|---------------------|-----------------------|----------------------------------|--------------|
| 22H / RSS-132 | 824 - 849 | 1.05 (test position 4) | 1.6 |
| 24E / RSS-133 | 1850 - 1910 | 1.58 (test position 2) | |

APPLICABLE STANDARDS AND TEST PROCEDURES:

| STANDARDS AND TEST PROCEDURES | TEST RESULTS |
|--|--------------|
| <ul style="list-style-type: none"> • FCC OET Bulletin 65 Supplement C and the following specific Test Procedures: <ul style="list-style-type: none"> ○ KDB 941225 D01 SAR test for 3G devices ○ 447498 D01 Mobile Portable RF Exposure v03r03 ○ 447498 D02 SAR Procedures for Dongle Xmtr v01 | Pass |
| <ul style="list-style-type: none"> • RSS-102 ISSUE 2 | Pass |

Compliance Certification Services, Inc. (CCS) tested the above equipment in accordance with the requirements set forth in the above standards. All indications of Pass/Fail in this report are opinions expressed by CCS based on interpretations and/or observations of test results. Measurement Uncertainties were not taken into account and are published for informational purposes only. The test results show that the equipment tested is capable of demonstrating compliance with the requirements as documented in this report.

Note: The results documented in this report apply only to the tested sample, under the conditions and modes of operation as described herein. This document may not be altered or revised in any way unless done so by CCS and all revisions are duly noted in the revisions section. Any alteration of this document not carried out by CCS will constitute fraud and shall nullify the document. This report must not be used by the client to claim product certification, approval, or endorsement by NVLAP, NIST, any agency of the Federal Government, or any agency of any government.

Approved & Released For CCS By:

Tested By:



SUNNY SHIH
 ENGINEERING SUPERVISOR
 COMPLIANCE CERTIFICATION SERVICES

CHAO YEN LIN
 EMC ENGINEER
 COMPLIANCE CERTIFICATION SERVICES

2. TEST METHODOLOGY

The tests documented in this report were performed in accordance with FCC OET Bulletin 65 Supplement C, IC RSS 102 Issue 2 and the following specific FCC Test Procedures.

- KDB 941225 D01 SAR test for 3G devices
- 447498 D01 Mobile Portable RF Exposure v03r03
- o447498 D02 SAR Procedures for Dongle Xmtr v01

3. FACILITIES AND ACCREDITATION

The test sites and measurement facilities used to collect data are located at 47173 Benicia Street, Fremont, California, USA.

CCS is accredited by NVLAP, Laboratory Code 200065-0. The full scope of accreditation can be viewed at <http://www.ccsemc.com>.

4. CALIBRATION AND UNCERTAINTY

4.1. MEASURING INSTRUMENT CALIBRATION

The measuring equipment utilized to perform the tests documented in this report has been calibrated in accordance with the manufacturer's recommendations, and is traceable to recognized national standards.

| Name of Equipment | Manufacturer | Type/Model | Serial No. | Cal. Due date | | |
|------------------------------|---------------|-------------|------------|-----------------------------|----|------|
| | | | | MM | DD | Year |
| Robot - Six Axes | Stäubli | RX90BL | N/A | N/A | | |
| Robot Remote Control | Stäubli | CS7MB | 3403-91535 | N/A | | |
| DASY4 Measurement Server | SPEAG | SEUMS001BA | 1041 | N/A | | |
| Probe Alignment Unit | SPEAG | LB (V2) | 261 | N/A | | |
| SAM Phantom (SAM1) | SPEAG | QD000P40CA | 1185 | N/A | | |
| SAM Phantom (SAM2) | SPEAG | QD000P40CA | 1050 | N/A | | |
| Oval Flat Phantom (ELI 4.0) | SPEAG | QD OVA001 B | 1003 | N/A | | |
| Electronic Probe kit | HP | 85070C | N/A | N/A | | |
| S-Parameter Network Analyzer | Agilent | 8753ES-6 | MY40001647 | 11 | 14 | 2009 |
| Signal Generator | Agilent | 8753ES-6 | MY40001647 | 11 | 14 | 2009 |
| E-Field Probe | SPEAG | EX3DV4 | 3686 | 3 | 23 | 1010 |
| Thermometer | ERTCO | 639-1S | 1718 | 5 | 1 | 2010 |
| Data Acquisition Electronics | SPEAG | DAE3 V1 | 427 | 10 | 20 | 2009 |
| System Validation Dipole | SPEAG | D835V2 | 4d002 | 6 | 22 | 2009 |
| System Validation Dipole | SPEAG | D900V2 | 108 | 1 | 21 | 2010 |
| System Validation Dipole | SPEAG | D1800V2 | 294 | 1 | 29 | 2010 |
| System Validation Dipole | SPEAG | D1900V2 | 5d043 | 1 | 29 | 2010 |
| System Validation Dipole | SPEAG | D2450V2 | 748 | 4 | 14 | 2010 |
| System Validation Dipole | SPEAG | D5GHzV2 | 1003 | 11 | 21 | 2009 |
| MXA Signal Analyzer | Agilent | N9020A | US48350984 | 10 | 23 | 2009 |
| ESG Vector Signal Generator | Agilent | E4438C | US44271090 | 9 | 17 | 2010 |
| Power Meter | Giga-tronics | 8651A | 8651404 | 1 | 11 | 2010 |
| Power Sensor | Giga-tronics | 80701A | 1834588 | 1 | 11 | 2010 |
| Amplifier | Mini-Circuits | ZVE-8G | 90606 | N/A | | |
| Amplifier | Mini-Circuits | ZHL-42W | D072701-5 | N/A | | |
| Simulating Liquid | CCS | H1900 | N/A | Within 24 hrs of first test | | |
| Simulating Liquid | CCS | M1900 | N/A | Within 24 hrs of first test | | |
| Simulating Liquid | CCS | H1800 | N/A | Within 24 hrs of first test | | |
| Simulating Liquid | CCS | M1800 | N/A | Within 24 hrs of first test | | |
| Simulating Liquid | CCS | H1700 | N/A | Within 24 hrs of first test | | |
| Simulating Liquid | CCS | M1700 | N/A | Within 24 hrs of first test | | |
| Simulating Liquid | CCS | H835 | N/A | Within 24 hrs of first test | | |
| Simulating Liquid | CCS | M835 | N/A | Within 24 hrs of first test | | |
| Simulating Liquid | CCS | H900 | N/A | Within 24 hrs of first test | | |
| Simulating Liquid | CCS | M900 | N/A | Within 24 hrs of first test | | |

4.2. MEASUREMENT UNCERTAINTY

Measurement uncertainty for 300 MHz – 3000 MHz

| Uncertainty component | Tol. (±%) | Probe Dist. | Div. | Ci (1g) | Ci (10g) | Std. Unc.(±%) | |
|--|-----------|-------------|-------|---------|----------|---------------|---------|
| | | | | | | Ui (1g) | Ui(10g) |
| Measurement System | | | | | | | |
| Probe Calibration | 4.80 | N | 1 | 1 | 1 | 4.80 | 4.80 |
| Axial Isotropy | 4.70 | R | 1.732 | 0.707 | 0.707 | 1.92 | 1.92 |
| Hemispherical Isotropy | 9.60 | R | 1.732 | 0.707 | 0.707 | 3.92 | 3.92 |
| Boundary Effects | 1.00 | R | 1.732 | 1 | 1 | 0.58 | 0.58 |
| Linearity | 4.70 | R | 1.732 | 1 | 1 | 2.71 | 2.71 |
| System Detection Limits | 1.00 | R | 1.732 | 1 | 1 | 0.58 | 0.58 |
| Readout Electronics | 1.00 | N | 1 | 1 | 1 | 1.00 | 1.00 |
| Response Time | 0.80 | R | 1.732 | 1 | 1 | 0.46 | 0.46 |
| Integration Time | 2.60 | R | 1.732 | 1 | 1 | 1.50 | 1.50 |
| RF Ambient Conditions - Noise | 1.59 | R | 1.732 | 1 | 1 | 0.92 | 0.92 |
| RF Ambient Conditions - Reflections | 0.00 | R | 1.732 | 1 | 1 | 0.00 | 0.00 |
| Probe Positioner Mechanical Tolerance | 0.40 | R | 1.732 | 1 | 1 | 0.23 | 0.23 |
| Probe Positioning With Respect to Phantom Shell algorithms for max. SAR evaluation | 2.90 | R | 1.732 | 1 | 1 | 1.67 | 1.67 |
| | 3.90 | R | 1.732 | 1 | 1 | 2.25 | 2.25 |
| Test sample Related | | | | | | | |
| Test Sample Positioning | 1.10 | N | 1 | 1 | 1 | 1.10 | 1.10 |
| Device Holder Uncertainty | 3.60 | N | 1 | 1 | 1 | 3.60 | 3.60 |
| Power and SAR Drift Measurement | 5.00 | R | 1.732 | 1 | 1 | 2.89 | 2.89 |
| Phantom and Tissue Parameters | | | | | | | |
| Phantom Uncertainty | 4.00 | R | 1.732 | 1 | 1 | 2.31 | 2.31 |
| Liquid Conductivity - Target | 5.00 | R | 1.732 | 0.64 | 0.43 | 1.85 | 1.24 |
| Liquid Conductivity - Meas. | 8.60 | N | 1 | 0.64 | 0.43 | 5.50 | 3.70 |
| Liquid Permittivity - Target | 5.00 | R | 1.732 | 0.6 | 0.49 | 1.73 | 1.41 |
| Liquid Permittivity - Meas. | 3.30 | N | 1 | 0.6 | 0.49 | 1.98 | 1.62 |
| | | | | | | | |
| Combined Standard Uncertainty | RSS | | | | | 11.44 | 10.49 |
| Expanded Uncertainty (95% Confidence Interval) | K=2 | | | | | 22.87 | 20.98 |
| Notes for table | | | | | | | |
| 1. Tol. - tolerance in influence quantity | | | | | | | |
| 2. N - Nomal | | | | | | | |
| 3. R - Rectangular | | | | | | | |
| 4. Div. - Divisor used to obtain standard uncertainty | | | | | | | |
| 5. Ci - is te sensitivity coefficient | | | | | | | |

5. EQUIPMENT UNDER TEST

USB Wireless Modem, Model USB305

| | |
|------------------------|---------------------------------------|
| Network: | UMTS (W-CDMA) 850/1900 GSM850/1900 |
| GPRS Multi-slot class: | (E)GPRS: Class 12 |
| Antenna(s): | Internal |

6. SYSTEM SPECIFICATIONS

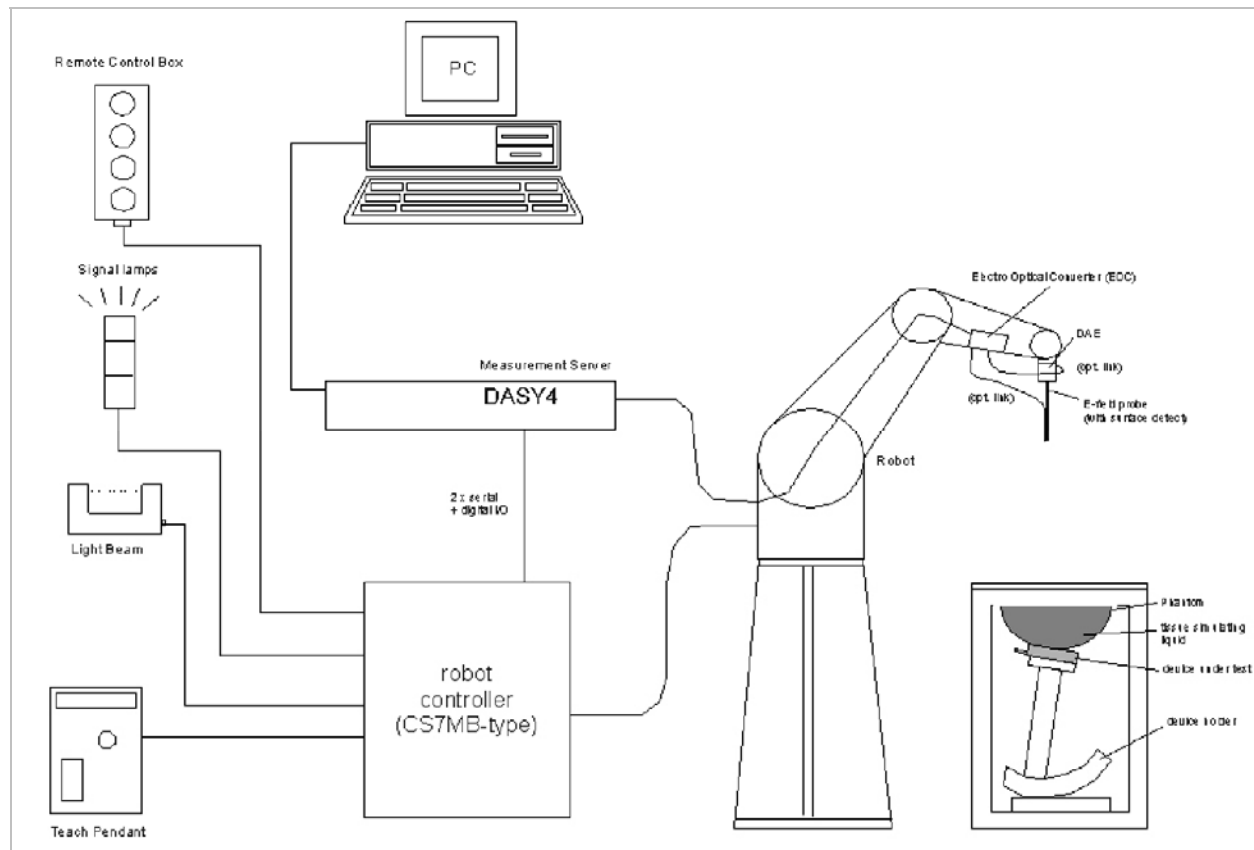

The DASY4 system for performing compliance tests consists of the following items:

- A standard high precision 6-axis robot (Stäubli RX family) with controller, teach pendant and software. An arm extension for accommodating the data acquisition electronics (DAE).
- A dosimetric probe, i.e., an isotropic E-field probe optimized and calibrated for usage in tissue simulating liquid. The probe is equipped with an optical surface detector system.
- A data acquisition electronics (DAE) which performs the signal amplification, signal multiplexing, AD-conversion, offset measurements, mechanical surface detection, collision detection, etc. The unit is battery powered with standard or rechargeable batteries. The signal is optically transmitted to the EOC.
- The function of the measurement server is to perform the time critical tasks such as signal filtering, control of the robot operation and fast movement interrupts.
- A probe alignment unit which improves the (absolute) accuracy of the probe positioning.
- A computer operating Windows 2000 or Windows XP.
- DASY4 software.
- Remote controls with teach pendant and additional circuitry for robot safety such as warning lamps, etc.
- The SAM twin phantom enabling testing left-hand and right-hand usage.
- The device holder for handheld mobile phones.
- Tissue simulating liquid mixed according to the given recipes.
- Validation dipole kits allowing to validate the proper functioning of the system.

7. COMPOSITION OF INGREDIENTS FOR TISSUE SIMULATING LIQUIDS

The following tissue formulations are provided for reference only as some of the parameters have not been thoroughly verified. The composition of ingredients may be modified accordingly to achieve the desired target tissue parameters required for routine SAR evaluation.

| Ingredients (% by weight) | Frequency (MHz) | | | | | | | | | |
|------------------------------|-----------------|-------|-------|------|-------|-------|-------|------|------|------|
| | 450 | | 835 | | 915 | | 1900 | | 2450 | |
| Tissue Type | Head | Body | Head | Body | Head | Body | Head | Body | Head | Body |
| Water | 38.56 | 51.16 | 41.45 | 52.4 | 41.05 | 56.0 | 54.9 | 40.4 | 62.7 | 73.2 |
| Salt (NaCl) | 3.95 | 1.49 | 1.45 | 1.4 | 1.35 | 0.76 | 0.18 | 0.5 | 0.5 | 0.04 |
| Sugar | 56.32 | 46.78 | 56.0 | 45.0 | 56.5 | 41.76 | 0.0 | 58.0 | 0.0 | 0.0 |
| HEC | 0.98 | 0.52 | 1.0 | 1.0 | 1.0 | 1.21 | 0.0 | 1.0 | 0.0 | 0.0 |
| Bactericide | 0.19 | 0.05 | 0.1 | 0.1 | 0.1 | 0.27 | 0.0 | 0.1 | 0.0 | 0.0 |
| Triton X-100 | 0.0 | 0.0 | 0.0 | 0.0 | 0.0 | 0.0 | 0.0 | 0.0 | 36.8 | 0.0 |
| DGBE | 0.0 | 0.0 | 0.0 | 0.0 | 0.0 | 0.0 | 44.92 | 0.0 | 0.0 | 26.7 |
| Dielectric Constant | 43.42 | 58.0 | 42.54 | 56.1 | 42.0 | 56.8 | 39.9 | 54.0 | 39.8 | 52.5 |
| Conductivity (S/m) | 0.85 | 0.83 | 0.91 | 0.95 | 1.0 | 1.07 | 1.42 | 1.45 | 1.88 | 1.78 |

Salt: 99+% Pure Sodium Chloride

Sugar: 98+% Pure Sucrose

Water: De-ionized, 16 MΩ+ resistivity

HEC: Hydroxyethyl Cellulose

DGBE: 99+% Di(ethylene glycol) butyl ether, [2-(2-butoxyethoxy)ethanol]

Triton X-100 (ultra pure): Polyethylene glycol mono [4-(1,1, 3, 3-tetramethylbutyl)phenyl]ether

8. LIQUID PARAMETERS CHECK

The simulating liquids should be checked at the beginning of a series of SAR measurements to determine if the dielectric parameters are within the tolerances of the specified target values. The relative permittivity and conductivity of the tissue material should be within $\pm 5\%$ of the values given in the table below.

Reference Values of Tissue Dielectric Parameters for Head and Body Phantom (for 150 – 3000 MHz and 5800 MHz)

The head tissue dielectric parameters recommended by the IEEE SCC-34/SC-2 in IEEE Standard 1528 have been incorporated in the following table. These head parameters are derived from planar layer models simulating the highest expected SAR for the dielectric properties and tissue thickness variations in a human head. Other head and body tissue parameters that have not been specified in P1528 are derived from the tissue dielectric parameters computed from the 4-Cole-Cole equations and extrapolated according to the head parameters specified in IEEE Standard 1528.

| Target Frequency (MHz) | Head | | Body | |
|------------------------|--------------|----------------|--------------|----------------|
| | ϵ_r | σ (S/m) | ϵ_r | σ (S/m) |
| 150 | 52.3 | 0.76 | 61.9 | 0.8 |
| 300 | 45.3 | 0.87 | 58.2 | 0.92 |
| 450 | 43.5 | 0.87 | 56.7 | 0.94 |
| 835 | 41.5 | 0.9 | 55.2 | 0.97 |
| 900 | 41.5 | 0.97 | 55 | 1.05 |
| 915 | 41.5 | 0.98 | 55 | 1.06 |
| 1450 | 40.5 | 1.2 | 54 | 1.3 |
| 1610 | 40.3 | 1.29 | 53.8 | 1.4 |
| 1800 – 2000 | 40 | 1.4 | 53.3 | 1.52 |
| 2450 | 39.2 | 1.8 | 52.7 | 1.95 |
| 3000 | 38.5 | 2.4 | 52 | 2.73 |
| 5800 | 35.3 | 5.27 | 48.2 | 6 |

(ϵ_r = relative permittivity, σ = conductivity and $\rho = 1000 \text{ kg/m}^3$)

8.1. LIQUID CHECK RESULTS FOR 1900 MHZ

Simulating Liquid Dielectric Parameters for Muscle 1900 MHz

Room Ambient Temperature = 24°C; Relative humidity = 40% Measured by: Sunny Shih

| f (MHz) | Muscle Liquid Parameters | | | Measured | Target | Delta (%) | Limit (%) |
|---------|--------------------------|--------|---|----------|--------|-----------|-----------|
| 1900 | e' | 52.994 | Relative Permittivity (ϵ_r): | 52.9936 | 53.3 | -0.57 | ± 5 |
| | e" | 14.250 | Conductivity (σ): | 1.50621 | 1.52 | -0.91 | ± 5 |

Liquid temperature: 23 deg. C

May 23, 2009 01:15 PM

| Frequency | e' | e" |
|--------------------|----------------|----------------|
| 1710000000. | 53.8467 | 13.5184 |
| 1720000000. | 53.8014 | 13.5201 |
| 1730000000. | 53.7845 | 13.5753 |
| 1740000000. | 53.7810 | 13.6522 |
| 1750000000. | 53.7422 | 13.7884 |
| 1760000000. | 53.6282 | 13.8932 |
| 1770000000. | 53.5147 | 13.9433 |
| 1780000000. | 53.4614 | 13.9243 |
| 1790000000. | 53.4335 | 13.9243 |
| 1800000000. | 53.3895 | 13.9458 |
| 1810000000. | 53.3462 | 13.9158 |
| 1820000000. | 53.2795 | 13.8743 |
| 1830000000. | 53.3039 | 13.8764 |
| 1840000000. | 53.3109 | 13.9959 |
| 1850000000. | 53.2474 | 14.1639 |
| 1860000000. | 53.1001 | 14.2838 |
| 1870000000. | 52.9709 | 14.2793 |
| 1880000000. | 52.9391 | 14.2278 |
| 1890000000. | 52.9668 | 14.2204 |
| 1900000000. | 52.9936 | 14.2499 |
| 1910000000. | 52.9561 | 14.2551 |

The conductivity (σ) can be given as:

$$\sigma = \omega \epsilon_0 e'' = 2 \pi f \epsilon_0 e''$$

where $f = \text{target } f * 10^6$

$$\epsilon_0 = 8.854 * 10^{-12}$$

Simulating Liquid Dielectric Parameters for Muscle 1900 MHz

Room Ambient Temperature = 24°C; Relative humidity = 40% Measured by: Chaoyen Lin

| f (MHz) | Muscle Liquid Parameters | | | Measured | Target | Delta (%) | Limit (%) |
|---------|--------------------------|--------|---|----------|--------|-----------|-----------|
| 1900 | e' | 52.895 | Relative Permittivity (ϵ_r): | 52.8945 | 53.3 | -0.76 | ± 5 |
| | e'' | 14.443 | Conductivity (σ): | 1.52659 | 1.52 | 0.43 | ± 5 |

Liquid temperature: 23 deg. C

May 26, 2009 01:35 PM

| Frequency | e' | e'' |
|--------------------|----------------|----------------|
| 1710000000. | 53.6070 | 13.7861 |
| 1720000000. | 53.5651 | 13.8338 |
| 1730000000. | 53.5687 | 13.9246 |
| 1740000000. | 53.5480 | 13.9877 |
| 1750000000. | 53.5384 | 14.0782 |
| 1760000000. | 53.4644 | 14.0983 |
| 1770000000. | 53.3883 | 14.1133 |
| 1780000000. | 53.3406 | 14.0865 |
| 1790000000. | 53.2824 | 14.0839 |
| 1800000000. | 53.2310 | 14.1125 |
| 1810000000. | 53.1451 | 14.1242 |
| 1820000000. | 53.0749 | 14.1557 |
| 1830000000. | 53.0539 | 14.2284 |
| 1840000000. | 53.0351 | 14.3502 |
| 1850000000. | 53.0084 | 14.4354 |
| 1860000000. | 52.9541 | 14.4908 |
| 1870000000. | 52.8947 | 14.4895 |
| 1880000000. | 52.9091 | 14.4474 |
| 1890000000. | 52.8906 | 14.4316 |
| 1900000000. | 52.8945 | 14.4427 |
| 1910000000. | 52.8349 | 14.4541 |

The conductivity (σ) can be given as:

$$\sigma = \omega \epsilon_0 e'' = 2 \pi f \epsilon_0 e''$$

where $f = \text{target } f * 10^6$

$$\epsilon_0 = 8.854 * 10^{-12}$$

8.2. LIQUID CHECK RESULTS FOR 835 MHZ

Simulating Liquid Dielectric Parameters for Muscle 900 MHz

Room Ambient Temperature = 24°C; Relative humidity = 40%

Measured by: Sunny Shih

| f (MHz) | Liquid Parameters | | | Measured | Target | Delta (%) | Limit (%) |
|---------|-------------------|-------|---|----------|--------|-----------|-----------|
| 835 | e' | 53.59 | Relative Permittivity (ϵ_r): | 53.592 | 55.2 | -2.91 | ± 5 |
| | e'' | 20.78 | Conductivity (σ): | 0.965 | 0.97 | -0.49 | ± 5 |

Liquid temperature: 23 deg. C

May 24, 2009 02:19 PM

| Frequency | e' | e'' |
|-------------------|----------------|----------------|
| 800000000. | 54.0125 | 21.2172 |
| 805000000. | 53.9342 | 21.1749 |
| 810000000. | 53.8546 | 21.0775 |
| 815000000. | 53.7715 | 20.9992 |
| 820000000. | 53.7312 | 20.9290 |
| 825000000. | 53.6980 | 20.8458 |
| 830000000. | 53.6201 | 20.7906 |
| 835000000. | 53.5920 | 20.7784 |
| 840000000. | 53.5575 | 20.7467 |
| 845000000. | 53.5143 | 20.7185 |
| 850000000. | 53.4836 | 20.7510 |
| 855000000. | 53.4208 | 20.7519 |
| 860000000. | 53.3721 | 20.7584 |
| 865000000. | 53.3373 | 20.7705 |
| 870000000. | 53.2626 | 20.7868 |
| 875000000. | 53.2276 | 20.8201 |
| 880000000. | 53.2029 | 20.8492 |
| 885000000. | 53.1478 | 20.8791 |
| 890000000. | 53.0890 | 20.8683 |
| 895000000. | 53.0495 | 20.8502 |
| 900000000. | 53.0041 | 20.7878 |

The conductivity (σ) can be given as:

$$\sigma = \omega \epsilon_0 e'' = 2 \pi f \epsilon_0 e''$$

where $f = \text{target } f * 10^6$

$$\epsilon_0 = 8.854 * 10^{-12}$$

9. SYSTEM CHECK

The system performance check is performed prior to any usage of the system in order to guarantee reproducible results. The system performance check verifies that the system operates within its specifications of $\pm 10\%$.

System Performance Check Measurement Conditions

- The measurements were performed in the flat section of the SAM twin phantom filled with Head or Body simulating liquid of the following parameters.
- The DASY4 system with an Isotropic E-Field Probe EX3DV3 was used for the measurements.
- The dipole was mounted on the small tripod so that the dipole feed point was positioned below the center marking of the flat phantom section and the dipole was oriented parallel to the body axis (the long side of the phantom). The standard measuring distance was 10 mm (above 1 GHz) and 15 mm (below 1 GHz) from dipole center to the simulating liquid surface.
- The coarse grid with a grid spacing of 15 mm was aligned with the dipole.
 For 5 GHz band - The coarse grid with a grid spacing of 10 mm was aligned with the dipole.
- Special 7x7x7 fine cube was chosen for cube
- Distance between probe sensors and phantom surface was set to 3 mm.
 For 5 GHz band - Distance between probe sensors and phantom surface was set to 2.5 mm
- The dipole input power (forward power) was $250 \text{ mW} \pm 3\%$.
- The results are normalized to 1 W input power.

IEEE Standard 1528-2003 Numerical reference SAR values (W/kg) for reference dipole and flat phantom

| Frequency (MHz) | Distance (mm) | 1g SAR [W/kg] | 10g SAR [W/kg] | Local SAR at surface (above feed-point) |
|-----------------|---------------|---------------|----------------|---|
| 300 | 15 | 3 | 2 | 4.4 |
| 450 | 15 | 4.9 | 3.3 | 7.2 |
| 835 | 15 | 9.5 | 6.2 | 4.1 |
| 900 | 15 | 10.8 | 6.9 | 16.4 |
| 1450 | 10 | 29 | 16 | 5.02 |
| 1800 | 10 | 38.1 | 19.8 | 69.5 |
| 1900 | 10 | 39.7 | 20.5 | 72.1 |
| 2000 | 10 | 41.1 | 21.1 | 74.6 |
| 2450 | 10 | 52.4 | 24 | 104.2 |
| 3000 | 10 | 63.8 | 25.7 | 104.2 |

Note: All SAR values normalized to 1 W forward power.

9.1. SYSTEM CHECK RESULTS FOR D1900V2

System Validation Dipole: D1900V2 SN: 5d043

Date: May 23, 2009

Ambient Temperature = 24°C; Relative humidity = 40%

Measured by: Sunny Shih

| Medium | CW Signal (MHz) | Forward power (mW) | Measured (Normalized to 1 W) | | Target | Delta (%) | Tolerance (%) |
|--------|-----------------|--------------------|------------------------------|------|--------|-----------|---------------|
| Body | 1900 | 250 | 1g SAR: | 40.7 | 39.8 | 2.26 | ±10 |
| | | | 10g SAR: | 21.3 | 20.8 | 2.40 | |

Date: May 26, 2009

Ambient Temperature = 24°C; Relative humidity = 40%

Measured by: Chaoyen Lin

| Medium | CW Signal (MHz) | Forward power (mW) | Measured (Normalized to 1 W) | | Target | Delta (%) | Tolerance (%) |
|--------|-----------------|--------------------|------------------------------|------|--------|-----------|---------------|
| Body | 1900 | 250 | 1g SAR: | 39.8 | 39.8 | 0.00 | ±10 |
| | | | 10g SAR: | 20.7 | 20.8 | -0.48 | |

9.2. SYSTEM CHECK RESULTS FOR D835V2

System Validation Dipole: D835V2 SN:4d002

Date: May 24, 2009

Ambient Temperature = 24°C; Relative humidity = 40%

Measured by: Sunny Shih

| Medium | CW Signal (MHz) | Forward power (mW) | Measured (Normalized to 1 W) | | Target | Delta (%) | Tolerance (%) |
|--------|-----------------|--------------------|------------------------------|-------|--------|-----------|---------------|
| Body | 835 | 250 | 1g SAR: | 10.11 | 9.71 | 4.12 | ±10 |
| | | | 10g SAR: | 6.62 | 6.38 | 3.76 | |

10. OUTPUT POWER VERIFICATION

10.1. GSM

GPRS (GMSK) - Coding Scheme: MCS4

| Band | Ch No. | Frequency | Conducted output power (dBm) | | | |
|---------|--------|-----------|------------------------------|--------|--------|--------|
| | | | 1 slot | 2 slot | 3 slot | 4 slot |
| GSM850 | 128 | 824.2 | 32.10 | 30.04 | 28.19 | 26.99 |
| | 190 | 836.6 | 32.10 | 30.03 | 28.16 | 26.99 |
| | 251 | 848.8 | 32.10 | 30.00 | 28.11 | 26.94 |
| GSM1900 | 512 | 1850.2 | 28.50 | 27.84 | 25.67 | 24.49 |
| | 661 | 1880 | 28.40 | 27.29 | 25.54 | 24.37 |
| | 810 | 1909.8 | 28.60 | 27.51 | 25.75 | 24.56 |

EGPRS (8PSK) - Coding Scheme: MCS9

| Band | Ch No. | Frequency | Conducted output power (dBm) | | | |
|---------|--------|-----------|------------------------------|--------|--------|--------|
| | | | 1 slot | 2 slot | 3 slot | 4 slot |
| GSM850 | 128 | 824.2 | 27.10 | 27.12 | 27.05 | 25.71 |
| | 190 | 836.6 | 26.90 | 26.94 | 26.90 | 25.85 |
| | 251 | 848.8 | 27.10 | 26.83 | 26.95 | 26.05 |
| GSM1900 | 512 | 1850.2 | 25.60 | 25.76 | 24.88 | 23.51 |
| | 661 | 1880 | 25.70 | 25.63 | 24.76 | 23.56 |
| | 810 | 1909.8 | 25.60 | 25.55 | 24.63 | 23.38 |

10.2. UMTS RELEASE 99

The following tests were completed according to the test requirements outlined in section 5.2 of the 3GPP TS34.121-1 V7.5.0 specification. The EUT supports power Class 3, which has a nominal maximum output power of 24 dBm (+1.7/-3.7). A summary of these settings are illustrated below:

| | Mode | Rel99 |
|------------------------|-------------------------|----------------|
| | Subtest | - |
| WCDMA General Settings | Loopback Mode | Test Mode 1 |
| | Rel99 RMC | 12.2kbps RMC |
| | HSDPA FRC | Not Applicable |
| | HSUPA Test | Not Applicable |
| | Power Control Algorithm | Algorithm2 |
| | β_c | Not Applicable |
| | β_d | Not Applicable |
| | β_{ec} | Not Applicable |
| | β_c/β_d | 8/15 |
| | β_{hs} | Not Applicable |
| | β_{ed} | Not Applicable |

Results

Rel 99 (12.2kps RMC)

| Band | Mode | UL Ch No. | DL Ch No. | f (MHz) | O/P Power (dBm) |
|-----------------------|-----------------------|-----------|-----------|---------|-----------------|
| UMTS850 (Band V) | Rel 99 12.2kps RMC | 4132 | 4357 | 826.4 | 22.61 |
| | | 4182 | 4407 | 836.4 | 22.63 |
| | | 4233 | 4458 | 846.6 | 22.48 |
| UMTS1900 (Band II) | Rel 99 12.2kps RMC | 9262 | 9662 | 1852.4 | 22.49 |
| | | 9400 | 9800 | 1880.0 | 22.65 |
| | | 9538 | 9938 | 1907.6 | 22.11 |

10.3. UMTS HSDPA

The following 4 Sub-tests were completed according to Release 6 procedures in section 5.2 of 3GPP TS34.121. A summary of these settings are illustrated below:

| | Mode | Rel6 HSDPA | Rel6 HSDPA | Rel6 HSDPA | Rel6 HSDPA |
|-------------------------------|--------------------------------------|----------------|------------|------------|------------|
| | Subtest | 1 | 2 | 3 | 4 |
| WCDMA General Settings | Loopback Mode | Test Mode 1 | | | |
| | Rel99 RMC | 12.2kbps RMC | | | |
| | HSDPA FRC | H-Set1 | | | |
| | HSUPA Test | Not Applicable | | | |
| | Power Control Algorithm | Algorithm 2 | | | |
| | β_c | 2/15 | 12/15 | 15/15 | 15/15 |
| | β_d | 15/15 | 15/15 | 8/15 | 4/15 |
| | Bd (SF) | 64 | | | |
| | β_{ec} | - | - | - | - |
| | β_c/β_d | 2/15 | 12/15 | 15/8 | 15/4 |
| | β_{hs} | 4/15 | 24/15 | 30/15 | 30/15 |
| | β_{ed} | Not Applicable | | | |
| | CM (dB) | 0 | 1 | 1.5 | 1.5 |
| MPR (dB) | 0 | 0 | 0.5 | 0.5 | |
| HSDPA Specific Settings | DACK | 8 | | | |
| | DNAK | 8 | | | |
| | DCQI | 8 | | | |
| | Ack-Nack repetition factor | 3 | | | |
| | CQI Feedback (Table 5.2B.4) | 4ms | | | |
| | CQI Repetition Factor (Table 5.2B.4) | 2 | | | |
| | Ahs = β_{hs}/β_c | 30/15 | | | |

Results

| Rel 6 HSDPA | | | | | |
|-----------------------|-----------|-----------|-----------|---------|-----------------|
| Band | Mode | UL Ch No. | DL Ch No. | f (MHz) | O/P Power (dBm) |
| UMTS850 (Band V) | Subtest 1 | 4132 | 4357 | 826.4 | 22.53 |
| | | 4182 | 4407 | 836.4 | 22.51 |
| | | 4233 | 4458 | 846.6 | 22.54 |
| | Subtest 2 | 4132 | 4357 | 826.4 | 22.40 |
| | | 4182 | 4407 | 836.4 | 22.41 |
| | | 4233 | 4458 | 846.6 | 22.42 |
| | Subtest 3 | 4132 | 4357 | 826.4 | 21.69 |
| | | 4182 | 4407 | 836.4 | 21.68 |
| | | 4233 | 4458 | 846.6 | 21.71 |
| | Subtest 4 | 4132 | 4357 | 826.4 | 21.63 |
| | | 4182 | 4407 | 836.4 | 21.63 |
| | | 4233 | 4458 | 846.6 | 21.66 |
| UMTS1900 (Band II) | Subtest 1 | 9262 | 9662 | 1852.4 | 22.22 |
| | | 9400 | 9800 | 1880.0 | 22.34 |
| | | 9538 | 9938 | 1907.6 | 22.10 |
| | Subtest 2 | 9262 | 9662 | 1852.4 | 22.18 |
| | | 9400 | 9800 | 1880.0 | 22.32 |
| | | 9538 | 9938 | 1907.6 | 22.06 |
| | Subtest 3 | 9262 | 9662 | 1852.4 | 21.54 |
| | | 9400 | 9800 | 1880.0 | 21.67 |
| | | 9538 | 9938 | 1907.6 | 21.47 |
| | Subtest 4 | 9262 | 9662 | 1852.4 | 21.51 |
| | | 9400 | 9800 | 1880.0 | 21.59 |
| | | 9538 | 9938 | 1907.6 | 21.48 |

10.4. UMTS Rel 6 HSPA (HSDPA & HSUPA)

The following 5 Sub-tests were completed according to Release 6 procedures in section 5.2 of 3GPP TS34.121. A summary of these settings are illustrated below:

| Mode | Rel6 HSPA | Rel6 HSPA | Rel6 HSPA | Rel6 HSPA | Rel6 HSPA | | | | | |
|-------------------------------|--------------------------------------|-----------|-----------|----------------|-----------|--|---|--|-------|-------|
| Subtest | 1 | 2 | 3 | 4 | 5 | | | | | |
| WCDMA General Settings | Loopback Mode | | | | | Test Mode 1 | | | | |
| | Rel99 RMC | | | | | 12.2kbps RMC | | | | |
| | HSDPA FRC | | | | | H-Set1 | | | | |
| | HSUPA Test | | | | | HSUPA Loopback | | | | |
| | Power Control Algorithm | | | | | Algorithm2 | | | | |
| | β_c | 11/15 | 6/15 | 15/15 | 2/15 | 15/15 | | | | |
| | β_d | 15/15 | 15/15 | 9/15 | 15/15 | 15/15 | | | | |
| | β_{ec} | 209/225 | 12/15 | 30/15 | 2/15 | 24/15 | | | | |
| | β_c/β_d | 11/15 | 6/15 | 15/9 | 2/15 | 15/15 | | | | |
| | β_{hs} | 22/15 | 12/15 | 30/15 | 4/15 | 30/15 | | | | |
| | β_{ed} | 1309/225 | 94/75 | 47/15 47/15 | 56/75 | 134/15 | | | | |
| | CM (dB) | 1.0 | 3.0 | 2.0 | 3.0 | 1.0 | | | | |
| MPR (dB) | 0 | 2 | 1 | 2 | 0 | | | | | |
| HSDPA Specific Settings | DACK | | | | | 8 | | | | |
| | DNAK | | | | | 8 | | | | |
| | DCQI | | | | | 8 | | | | |
| | Ack-Nack repetition factor | | | | | 3 | | | | |
| | CQI Feedback (Table 5.2B.4) | | | | | 4ms | | | | |
| | CQI Repetition Factor (Table 5.2B.4) | | | | | 2 | | | | |
| | Ahs = β_{hs}/β_c | | | | | 30/15 | | | | |
| HSUPA Specific Settings | D E-DPCCH | | | | | 6 | 8 | 8 | 5 | 7 |
| | DHARQ | | | | | 0 | 0 | 0 | 0 | 0 |
| | AG Index | | | | | 20 | 12 | 15 | 17 | 21 |
| | ETFCI (from 34.121 Table C.11.1.3) | | | | | 75 | 67 | 92 | 71 | 81 |
| | Associated Max UL Data Rate kbps | | | | | 242.1 | 174.9 | 482.8 | 205.8 | 308.9 |
| | Reference E_TFCIs | | | | | E-TFCI 11 E-TFCI PO 4 E-TFCI 67 E-TFCI PO 18 E-TFCI 71 E-TFCI PO 23 E-TFCI 75 E-TFCI PO 26 E-TFCI 81 E-TFCI PO 27 | E-TFCI 11 E-TFCI PO 4 E-TFCI 92 E-TFCI PO 18 | E-TFCI 11 E-TFCI PO 4 E-TFCI 67 E-TFCI PO 18 E-TFCI 71 E-TFCI PO 23 E-TFCI 75 E-TFCI PO 26 E-TFCI 81 E-TFCI PO 27 | | |

Results

Rel 6 HSPA

| Band | Mode | UL Ch No. | DL Ch No. | f (MHz) | O/P Power (dBm) |
|-----------------------|-----------|-----------|-----------|---------|-----------------|
| UMTS850 (Band V) | Subtest 1 | 4132 | 4357 | 826.4 | 21.14 |
| | | 4182 | 4407 | 836.4 | 21.08 |
| | | 4233 | 4458 | 846.6 | 20.71 |
| | Subtest 2 | 4132 | 4357 | 826.4 | 20.45 |
| | | 4182 | 4407 | 836.4 | 20.38 |
| | | 4233 | 4458 | 846.6 | 20.43 |
| | Subtest 3 | 4132 | 4357 | 826.4 | 21.81 |
| | | 4182 | 4407 | 836.4 | 21.83 |
| | | 4233 | 4458 | 846.6 | 21.86 |
| | Subtest 4 | 4132 | 4357 | 826.4 | 20.72 |
| | | 4182 | 4407 | 836.4 | 20.88 |
| | | 4233 | 4458 | 846.6 | 20.87 |
| | Subtest 5 | 4132 | 4357 | 826.4 | 21.50 |
| | | 4182 | 4407 | 836.4 | 20.21 |
| | | 4233 | 4458 | 846.6 | 20.25 |
| UMTS1900 (Band II) | Subtest 1 | 9262 | 9662 | 1852.4 | 20.27 |
| | | 9400 | 9800 | 1880.0 | 20.42 |
| | | 9538 | 9938 | 1907.6 | 20.41 |
| | Subtest 2 | 9262 | 9662 | 1852.4 | 20.37 |
| | | 9400 | 9800 | 1880.0 | 20.46 |
| | | 9538 | 9938 | 1907.6 | 20.46 |
| | Subtest 3 | 9262 | 9662 | 1852.4 | 21.81 |
| | | 9400 | 9800 | 1880.0 | 21.92 |
| | | 9538 | 9938 | 1907.6 | 21.92 |
| | Subtest 4 | 9262 | 9662 | 1852.4 | 20.85 |
| | | 9400 | 9800 | 1880.0 | 21.06 |
| | | 9538 | 9938 | 1907.6 | 21.01 |
| | Subtest 5 | 9262 | 9662 | 1852.4 | 20.37 |
| | | 9400 | 9800 | 1880.0 | 21.23 |
| | | 9538 | 9938 | 1907.6 | 20.46 |

Note: In HSUPA operation, the output power is reduced relative to the tuning target power for WCDMA. This device employs two power control mechanisms: MPR and E-TFC MPR. In each Subtest mode, the mechanism with the higher power reduction dominates. As a result, the overall MPR for each of the Subtest modes is as follows:

| Maximum Power Reduction (MPR) | | | | |
|-------------------------------|----------------|----------------|----------------|----------------|
| Subtest mode 1 | Subtest mode 2 | Subtest mode 3 | Subtest mode 4 | Subtest mode 5 |
| 1.5 dB | 2.0 dB | 1.0 dB | 2.0 dB | 1.5 dB |

11. SUMMARY OF TEST RESULTS

If the SAR measured at the middle channel for each test configuration is at least 3.0 dB (0.8 mW/g) lower than the SAR limit (1.6 mW/g), testing at the high and low channels is optional for such test configuration(s).

11.1. UMTS BAND II (1900 MHZ)

11.1.1. TEST POSITION 1 (FRONT)

| Sep. dist. (mm) | Mode | UL Ch No. | DL Ch No. | f (MHz) | 1g SAR (mW/g) | Limit (mW/g) |
|-----------------|------|-----------|-----------|---------|---------------|--------------|
| 5 | R99 | 9262 | 9662 | 1852.4 | 1.51 | 1.6 |
| | | 9400 | 9800 | 1880.0 | 1.57 | |
| | | 9538 | 9938 | 1907.6 | 1.51 | |

11.1.2. TEST POSITION 2 (BACK)

| Sep. dist. (mm) | Mode | UL Ch No. | DL Ch No. | f (MHz) | 1g SAR (mW/g) | Limit (mW/g) |
|-----------------|------|-----------|-----------|---------|---------------|--------------|
| 5 | R99 | 9262 | 9662 | 1852.4 | 1.55 | 1.6 |
| | | 9400 | 9800 | 1880.0 | 1.58 | |
| | | 9538 | 9938 | 1907.6 | 1.31 | |

11.1.3. TEST POSITION 3 (SIDE)

| Sep. dist. (mm) | Mode | UL Ch No. | DL Ch No. | f (MHz) | 1g SAR (mW/g) | Limit (mW/g) |
|-----------------|------|-----------|-----------|---------|---------------|--------------|
| 5 | R99 | 9262 | 9662 | 1852.4 | 1.58 | 1.6 |
| | | 9400 | 9800 | 1880.0 | 1.54 | |
| | | 9538 | 9938 | 1907.6 | 1.54 | |

11.1.4. TEST POSITION 4 (SIDE)

| Sep. dist. (mm) | Mode | UL Ch No. | DL Ch No. | f (MHz) | 1g SAR (mW/g) | Limit (mW/g) |
|-----------------|------|-----------|-----------|---------|---------------|--------------|
| 5 | R99 | 9262 | 9662 | 1852.4 | | 1.6 |
| | | 9400 | 9800 | 1880.0 | 0.433 | |
| | | 9538 | 9938 | 1907.6 | | |

11.1.5. TEST POSITION 5 (TIP)

| Sep. dist. (mm) | Mode | UL Ch No. | DL Ch No. | f (MHz) | 1g SAR (mW/g) | Limit (mW/g) |
|-----------------|------|-----------|-----------|---------|---------------|--------------|
| 5 | R99 | 9262 | 9662 | 1852.4 | | 1.6 |
| | | 9400 | 9800 | 1880.0 | 0.362 | |
| | | 9538 | 9938 | 1907.6 | | |

11.2. GSM1900

11.2.1. TEST POSITION 1 (FRONT)

| Sep. dist. (mm) | Mode | Ch No. | f (MHz) | 1g SAR (mW/g) | Limit (mW/g) |
|-----------------|--------------|--------|---------|---------------|--------------|
| 5 | GPRS 2 slots | 512 | 1850.2 | 1.290 | 1.6 |
| | | 661 | 1880.0 | 1.180 | |
| | | 810 | 1909.8 | 0.981 | |

11.2.2. TEST POSITION 2 (BACK)

| Sep. dist. (mm) | Mode | Ch No. | f (MHz) | 1g SAR (mW/g) | Limit (mW/g) |
|-----------------|--------------|--------|---------|---------------|--------------|
| 5 | GPRS 1 slots | 661 | 1880.0 | 0.853 | 1.6 |
| | GPRS 2 slots | 661 | 1880.0 | 1.240 | |
| | GPRS 3 slots | 661 | 1880.0 | 1.220 | |
| | GPRS 4 slots | 661 | 1880.0 | 1.230 | |
| | GPRS 2 slots | 512 | 1850.2 | 1.520 | |
| | | 810 | 1909.8 | 0.895 | |

11.2.3. TEST POSITION 3 (SIDE)

| Sep. dist. (mm) | Mode | Ch No. | f (MHz) | 1g SAR (mW/g) | Limit (mW/g) |
|-----------------|--------------|--------|---------|---------------|--------------|
| 5 | GPRS 2 slots | 512 | 1850.2 | 1.28 | 1.6 |
| | | 661 | 1880.0 | 1.31 | |
| | | 810 | 1909.8 | 1.13 | |

11.2.4. TEST POSITION 4 (SIDE)

| Sep. dist. (mm) | Mode | Ch No. | f (MHz) | 1g SAR (mW/g) | Limit (mW/g) |
|-----------------|--------------|--------|---------|---------------|--------------|
| 5 | GPRS 2 slots | 512 | 1850.2 | | 1.6 |
| | | 661 | 1880.0 | 0.282 | |
| | | 810 | 1909.8 | | |

11.2.5. TEST POSITION 5 (TIP)

| Sep. dist. (mm) | Mode | Ch No. | f (MHz) | 1g SAR (mW/g) | Limit (mW/g) |
|-----------------|--------------|--------|---------|---------------|--------------|
| 5 | GPRS 2 slots | 512 | 1850.2 | | 1.6 |
| | | 661 | 1880.0 | 0.311 | |
| | | 810 | 1909.8 | | |

11.3. UMTS BAND V (850 MHZ)

11.3.1. TEST POSITION 1

| Sep. dist. (mm) | Mode | UL Ch No. | DL Ch No. | f (MHz) | 1g SAR (mW/g) | Limit (mW/g) |
|-----------------|--------------------|-----------|-----------|---------|---------------|--------------|
| 5 | R99 12.2kps RMC | 4132 | 4357 | 826.4 | | 1.6 |
| | | 4182 | 4407 | 836.4 | 0.579 | |
| | | 4233 | 4458 | 846.6 | | |

11.3.2. TEST POSITION 2

| Sep. dist. (mm) | Mode | UL Ch No. | DL Ch No. | f (MHz) | 1g SAR (mW/g) | Limit (mW/g) |
|-----------------|--------------------|-----------|-----------|---------|---------------|--------------|
| 5 | R99 12.2kps RMC | 4132 | 4357 | 826.4 | | 1.6 |
| | | 4182 | 4407 | 836.4 | 0.736 | |
| | | 4233 | 4458 | 846.6 | | |

11.3.3. TEST POSITION 3 (SIDE)

| Sep. dist. (mm) | Mode | UL Ch No. | DL Ch No. | f (MHz) | 1g SAR (mW/g) | Limit (mW/g) |
|-----------------|--------------------|-----------|-----------|---------|---------------|--------------|
| 5 | R99 12.2kps RMC | 4132 | 4357 | 826.4 | | 1.6 |
| | | 4182 | 4407 | 836.4 | 0.351 | |
| | | 4233 | 4458 | 846.6 | | |

11.3.4. TEST POSITION 4 (SIDE)

| Sep. dist. (mm) | Mode | UL Ch No. | DL Ch No. | f (MHz) | 1g SAR (mW/g) | Limit (mW/g) |
|-----------------|--------------------|-----------|-----------|---------|---------------|--------------|
| 5 | R99 12.2kps RMC | 4132 | 4357 | 826.4 | 0.941 | 1.6 |
| | | 4182 | 4407 | 836.4 | 0.907 | |
| | | 4233 | 4458 | 846.6 | 0.694 | |

11.3.5. TEST POSITION 5 (TIP)

| Sep. dist. (mm) | Mode | UL Ch No. | DL Ch No. | f (MHz) | 1g SAR (mW/g) | Limit (mW/g) |
|-----------------|--------------------|-----------|-----------|---------|---------------|--------------|
| 5 | R99 12.2kps RMC | 4132 | 4357 | 826.4 | | 1.6 |
| | | 4182 | 4407 | 836.4 | 0.220 | |
| | | 4233 | 4458 | 846.6 | | |

11.4. GSM850

11.4.1. TEST POSITION 1

| Sep. dist. (mm) | Mode | Ch No. | f (MHz) | 1g SAR (mW/g) | Limit (mW/g) |
|-----------------|---------|--------|---------|---------------|--------------|
| 5 | 2 slots | 190 | 836.6 | 0.433 | 1.6 |
| | 3 slots | 190 | 836.6 | 0.430 | |
| | 4 slots | 190 | 836.6 | 0.431 | |

11.4.2. TEST POSITION 2

| Sep. dist. (mm) | Mode | Ch No. | f (MHz) | 1g SAR (mW/g) | Limit (mW/g) |
|-----------------|--------------|--------|---------|---------------|--------------|
| 5 | GPRS 2 slots | 128 | 824.2 | | 1.6 |
| | | 190 | 836.6 | 0.558 | |
| | | 251 | 848.8 | | |

11.4.3. TEST POSITION 3 (SIDE)

| Sep. dist. (mm) | Mode | Ch No. | f (MHz) | 1g SAR (mW/g) | Limit (mW/g) |
|-----------------|--------------|--------|---------|---------------|--------------|
| 5 | GPRS 2 slots | 128 | 824.2 | | 1.6 |
| | | 190 | 836.6 | 0.278 | |
| | | 251 | 848.8 | | |

11.4.4. TEST POSITION 4 (SIDE)

| Sep. dist. (mm) | Mode | Ch No. | f (MHz) | 1g SAR (mW/g) | Limit (mW/g) |
|-----------------|--------------|--------|---------|---------------|--------------|
| 5 | GPRS 2 slots | 128 | 824.2 | 1.050 | 1.6 |
| | | 190 | 836.6 | 0.834 | |
| | | 251 | 848.8 | 0.465 | |

11.4.5. TEST POSITION 5 (SIDE)

| Sep. dist. (mm) | Mode | Ch No. | f (MHz) | 1g SAR (mW/g) | Limit (mW/g) |
|-----------------|--------------|--------|---------|---------------|--------------|
| 5 | GPRS 2 slots | 128 | 824.2 | | 1.6 |
| | | 190 | 836.6 | 0.205 | |
| | | 251 | 848.8 | | |

12. WORST-CASE SAR TEST PLOTS

WORST-CASE SAR PLOT for Part 22H - BODY POSITION

Date/Time: 5/25/2009 1:05:24 AM

Test Laboratory: Compliance Certification Services

GSM850 - Test Position 4

DUT: Sierra Wireless; Type: USB305; Serial: n/a

Communication System: GSM850; Frequency: 824.2 MHz; Duty Cycle: 1:4
Medium parameters used: $f = 825$ MHz; $\sigma = 0.957$ mho/m; $\epsilon_r = 53.7$; $\rho = 1000$ kg/m³
Phantom section: Flat Section

Room Ambient Temperature: 24.0 deg. C; Liquid Temperature: 23.0 deg. C

DASY4 Configuration:

- Area Scan setting - Find Secondary Maximum Within: 2.0 dB and with a peak SAR value greater than 0.0012W/kg
- Probe: EX3DV4 - SN3686; ConvF(8.7, 8.7, 8.7); Calibrated: 3/23/2009
- Sensor-Surface: 3mm (Mechanical Surface Detection)
- Electronics: DAE3 Sn427; Calibrated: 10/20/2008
- Phantom: Flat Phantom ELI4.0; Type: QDOVA001BA; Serial: SN:XXXX
- Measurement SW: DASY4, V4.7 Build 80; Postprocessing SW: SEMCAD, V1.8 Build 186

L-ch_GPRS 2 slots/Area Scan (7x8x1): Measurement grid: dx=15mm, dy=15mm
Maximum value of SAR (measured) = 1.14 mW/g

L-ch_GPRS 2 slots/Zoom Scan (7x7x9)/Cube 0: Measurement grid: dx=5mm, dy=5mm, dz=3mm
Reference Value = 14.3 V/m; Power Drift = -0.434 dB
Peak SAR (extrapolated) = 1.63 W/kg
SAR(1 g) = 1.05 mW/g; SAR(10 g) = 0.670 mW/g
Maximum value of SAR (measured) = 1.24 mW/g

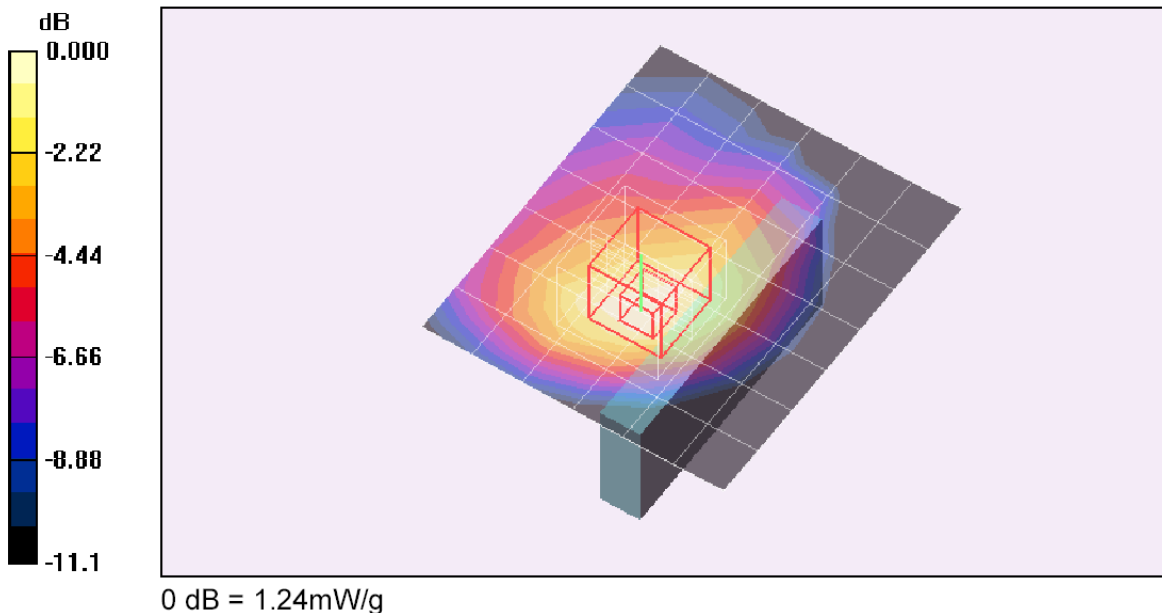

WORST-CASE SAR PLOT for Part 24E- BODY POSITION

Date/Time: 5/26/2009 4:50:49 PM

Test Laboratory: Compliance Certification Services

Band II - Test Position 2

DUT: Sierra Wireless; Type: USB305; Serial: n/a

Communication System: PCS 1900; Frequency: 1880 MHz; Duty Cycle: 1:1
Medium parameters used: $f = 1880$ MHz; $\sigma = 1.51$ mho/m; $\epsilon_r = 52.9$; $\rho = 1000$ kg/m³
Phantom section: Flat Section

Room Ambient Temperature: 24.0 deg. C; Liquid Temperature: 23.0 deg. C

DASY4 Configuration:

- Area Scan setting - Find Secondary Maximum Within: 2.0 dB and with a peak SAR value greater than 0.0012W/kg
- Probe: EX3DV4 - SN3686; ConvF(6.85, 6.85, 6.85); Calibrated: 3/23/2009
- Sensor-Surface: 3mm (Mechanical Surface Detection)
- Electronics: DAE3 Sn427; Calibrated: 10/20/2008
- Phantom: Flat Phantom ELI4.0; Type: QDOVA001BA; Serial: SN:XXXX
- Measurement SW: DASY4, V4.7 Build 80; Postprocessing SW: SEMCAD, V1.8 Build 186

M-ch_Band II R99/Area Scan (6x8x1): Measurement grid: dx=15mm, dy=15mm
Maximum value of SAR (measured) = 1.69 mW/g

M-ch_Band II R99/Zoom Scan (7x7x9)/Cube 0: Measurement grid: dx=5mm, dy=5mm, dz=3mm
Reference Value = 12.5 V/m; Power Drift = -1.15 dB
Peak SAR (extrapolated) = 2.52 W/kg
SAR(1 g) = 1.58 mW/g; SAR(10 g) = 0.929 mW/g
Maximum value of SAR (measured) = 1.88 mW/g

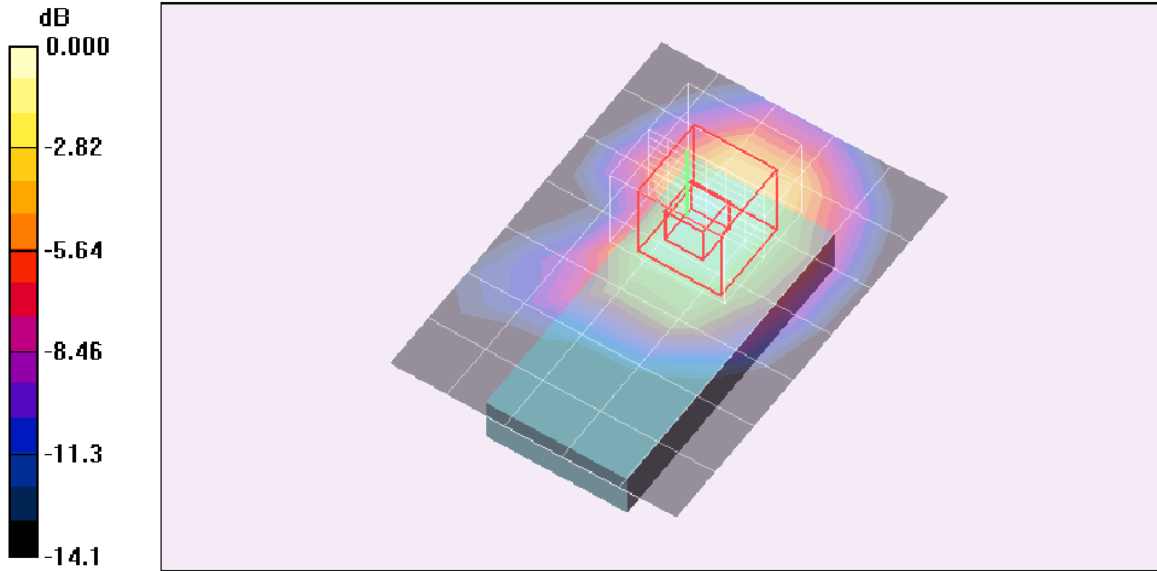

13. ATTACHMENTS

| No. | Contents | No. of page (s) |
|-----|--|-----------------|
| 1 | System Performance Check Plots | 6 |
| 2-1 | SAR Test Plots for UMTS 1900 | 14 |
| 2-2 | SAR Test Plots for GSM 1900 | 17 |
| 2-3 | SAR Test Plots for UMTS 850 | 8 |
| 2-4 | SAR Test Plots for GSM 850 | 10 |
| 3 | Certificate of E-Field Probe - EX3DV3SN3531 | 10 |
| 4 | Certificate of System Validation Dipole - D835V2 SN:4d002 | 9 |
| 5 | Certificate of System Validation Dipole - D1900V2 SN:5d043 | 9 |