



SL9090

Test Report

FOR

FCC and IC Certifications

IC: 2417C–SL9090
FCC ID: N7NSL9090

© 2009 Sierra Wireless, Inc.

This document contains information which is proprietary and confidential to Sierra Wireless, Inc. Disclosure to persons other than the officers, employees, agents, or subcontractors of the Company or licensee of this document without the prior written permission of Sierra Wireless, Inc. is strictly prohibited.

Table of Contents

1	Introduction and Purpose	4
2	Test Summary	4
3	Description of Equipment under Test.....	4
4	RF Power Output	5
4.1	Test Procedure	5
4.2	Test Equipment.....	5
4.3	Test Results GSM/EDGE (GMSK: MCS4; 8-PSK: MCS9)	6
4.4	Test Results UMTS.....	6
4.4.1	Test 1: RF Output Power Results for WCDMA R99.....	6
4.4.2	Test 2: RF Output Power Results for HSDPA Rel6.....	7
4.4.3	Test 3: RF Output Power Results for HSPA (HSDPA & HSUPA) Rel6.....	9
4.5	Test Settings for UMTS Mode on CMU200	11
5	Occupied Bandwidth.....	15
5.1	Test Procedure	15
5.2	Test Equipment.....	15
5.3	Test Results	15
5.3.1	GSM Results.....	16
5.3.2	WCDMA Results	16
5.4	Test Plots.....	17
6	Out of Band Emissions at Antenna Terminals	26
6.1	Test Procedure	26
6.2	Test Equipment.....	26
6.3	Test Results	27
6.4	Test Plots.....	28
7	Block Edge Compliance	64
7.1	Test Procedure	64
7.2	Test Equipment.....	64
7.3	Test Results	64
7.4	Test Plots.....	65
8	Frequency Stability versus Temperature	71
8.1	Summary of Results.....	71
8.2	Test Procedure	71
8.3	Test Equipment.....	71
8.4	Test Results	72
8.4.1	GSM Frequency Error over Temperature	72
8.4.2	UMTS Frequency Error over Temperature	72
9	Frequency Stability versus Voltage	73
9.1	Summary of Results.....	73
9.2	Test Procedure	73
9.3	Test Equipment.....	73
9.4	Test Results	74
9.4.1	GSM Frequency Error over Voltage.....	74

SIERRA WIRELESS, INC.

FCC Part 22, 24 / RSS 132, 133	SL9090	May30, 2012	Page 3 of 74
--------------------------------	--------	-------------	--------------

9.4.2 *UMTS Frequency Error over Voltage* 74

SIERRA WIRELESS, INC.

FCC Part 22, 24 / RSS 132, 133	SL9090	May30, 2012	Page 4 of 74
--------------------------------	--------	-------------	--------------

1 Introduction and Purpose

This document provides test data for the SL9090 modem intended for FCC and Industry Canada certifications. The tests included in this report are limited to all conducted tests required. The radiated tests were performed at an external test facility.

2 Test Summary

FCC Rule	IC Standards	DESCRIPTION OF TEST	RESULT	PAGE
2.1046	RSS-132, 4.4 Issue 2 RSS-133, 6.4 Issue 5	RF Power Output	Complies	5
2.1049	RSS-Gen, 4.6 Issue 2	Occupied Bandwidth	Complies	15
2.1051, 22.901(d) 22.917, 24.238(a)	RSS-132, 4.5 Issue 2 RSS-133, 6.5 Issue 5	Out of Band Emissions at Antenna Terminals	Complies	26
2.1053	RSS-132, 4.5 Issue 2 RSS-133, 6.5 Issue 5	Field Strength of Spurious Radiation	Complies	See QuieTek Report
2.1055	RSS-132, 4.3 Issue 2 RSS-133, 6.3 Issue 5	Frequency Stability versus Temperature	Complies	7171
2.1055	RSS-132, 4.3 Issue 2 RSS-133, 6.3 Issue 5	Frequency Stability versus Voltage	Complies	73

3 Description of Equipment under Test

The SL9090 modem, referred to as "EUT" hereafter, is a multi-band wireless modem operating on the GSM/GPRS/EDGE/UMTS networks. In the US and Canada, only cellular and PCS bands are used for GSM/GPRS/UMTS operation, so this test report only contains data for these two bands (850MHz and 1900MHz).

4 RF Power Output

FCC 2.1046

4.1 Test Procedure

The transmitter output was connected to a Rohde & Schwarz CMU200 Test Set and configured to operate at maximum power in a call. The power was measured using the spectrum analyzer at three equally spaced operating frequencies for each band. The RBW was set to 300 KHz for the GSM and EDGE measurements and 5MHz for the WCDMA measurements. The spectrum analyzer was set to measure the RF output power with the cable and coupler losses accounted for.

Test Setup

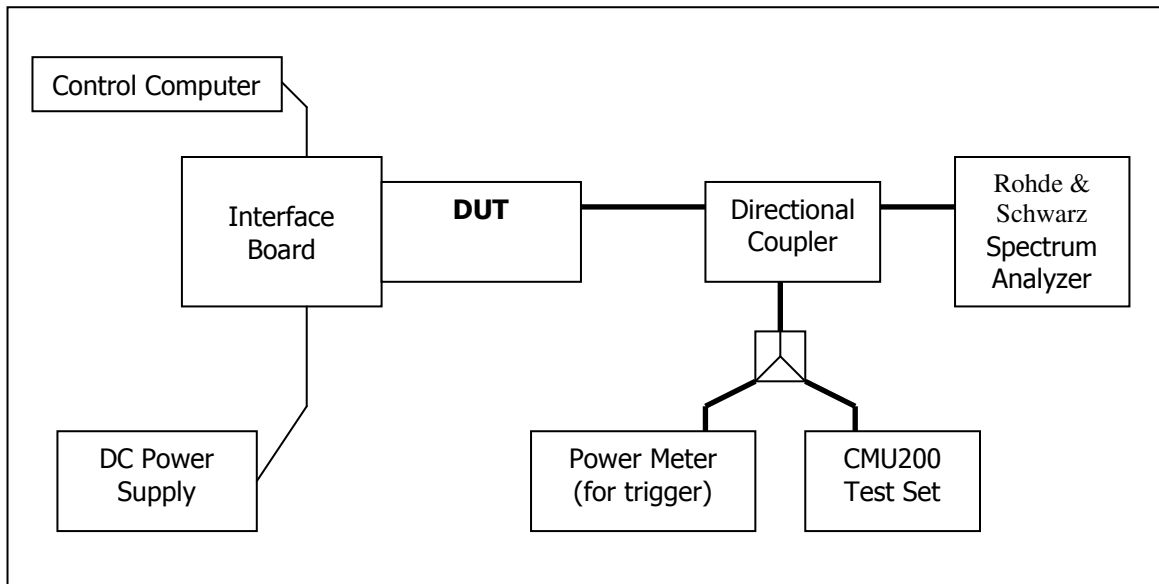

4.2 Test Equipment

EQUIPMENT	MANUFACTURER	MODEL NO.	SERIAL NO.	CAL. DATE
Control Computer	TC	Generic PC	100488	N/A
Wireless Test Set	Rohde & Schwarz	CMU200	117788	November 17, 2011
Spectrum Analyzer	Rohde & Schwarz	FSU	200078	November 15, 2011
DC Power Supply	HP	6632A	3530A	N/A
Interface Board	Shop built	ATEMux	N/A	N/A
Directional Coupler	Pasternack	PE2209-10	N/A	N/A

SIERRA WIRELESS, INC.

FCC Part 22, 24 / RSS 132, 133	SL9090	May30, 2012	Page 6 of 74
--------------------------------	--------	-------------	--------------

4.3 Test Results GSM/EDGE (GMSK: MCS4; 8-PSK: MCS9)

Frequency (MHz)	Channel	GMSK Mode		8-PSK Mode	
		RMS Power(dBm)	Peak Power(dBm)	RMS Power dBm)	Peak Power(dBm)
824.2	128	32.40	32.50	26.62	29.90
836.4	189	32.44	32.61	26.56	29.80
848.8	251	32.44	32.60	26.54	29.80
1850.2	512	29.25	29.40	25.27	28.80
1880.0	661	29.18	29.30	25.16	28.30
1909.8	810	29.36	29.52	25.1	28.10

4.4 Test Results UMTS

4.4.1 Test 1: RF Output Power Results for WCDMA R99

The following tests were completed according to the test requirements outlined in section 5.2 of the 3GPP TS34.121-1 V7.5.0 specification. The EUT supports power Class 3, which has a nominal maximum output power of 24 dBm (+1.7/-3.7). RMC 12.2kps is used for this testing.

The test was performed according to section 5.2 of the 3GPP TS34.121-1 V7.5.

Frequency (MHz)	Channel	WCDMA R99	
		RMS Power (dBm)	Peak Power (dBm)
826.4	4132	23.03	26.46
836.4	4182	22.95	26.35
846.6	4233	23.03	26.39
1852.4	9262	22.58	26.10
1880.0	9400	22.63	26.10
1907.6	9538	22.57	25.96

Note: The results above reflect max power with all up bits.

SIERRA WIRELESS, INC.

FCC Part 22, 24 / RSS 132, 133	SL9090	May30, 2012	Page 7 of 74
--------------------------------	--------	-------------	--------------

4.4.2 Test 2: RF Output Power Results for HSDPA Rel6

The EUT supports Category 8 FDD HS-DSCH physical layer. As stated in the 3GPP TS25.306 V7.3.0 Table 5.1a, the details of Category 8 are as follows:

- Maximum of 10 E-DSCH received codes
- Minimum 1 inter-TTI interval
- Maximum 14411bits in an E-DSCH transport block received within an E-DSCH TTI
- Total number of soft channel bits is 134400
- Support of QPSK and 16QAM

A detailed list of all settings used is included 4.5.

The following Sub-Tests were completed according to the test requirements outlined in section 5.2A of the 3GPP TS34.121-1 V7.5.0 specification. All TX RMS and Peak power requirements for Power Class 3 were met according to table 5.2AA.5 and achieved through the outlined test procedure in section 5.2AA.4.2. All UE channels and power ratio's are set according to table C10.1.4 in the 3GPP TS34.121-1 V7.5.0 specification. A summary of these settings is illustrated below:

Subtest	Mode	Call Type	RMC (kbps)	HSDPA FRC	Power Class 3 Max Limit dBm	β_c/β_d	β_{hs}	CM (db)	MPR (db)
1	HSDPA	PS	12.2	H-Set 1 QPSK	24 (+1.7/-3.7 db)	2 /15	4/15	0.0	0.0
2	HSDPA	PS	12.2	H-Set 1 QPSK	24 (+1.7/-3.7 db)	12 /15	24/15	1.0	0.0
3	HSDPA	PS	12.2	H-Set 1 QPSK	23.5 (+2.2/-3.7 db)	15 /8	30/15	1.5	0.5
4	HSDPA	PS	12.2	H-Set 1 QPSK	23.5 (+2.2/-3.7 db)	15 /4	30/15	1.5	0.5

Note: The recommended HSDPA MPRs are implemented as per following sub-tests.

4.4.2.1 Sub-Test 1

$\beta_c=2/15$, $\beta_d=15/15$, $\beta_{hs}=4/15$. MPR=0dB translates the min. and max. power limits to 20.3dBm and 25.7dBm respectively.

Frequency (MHz)	Channel	Power (dBm)	Comments
		20.3dBm<Measured RMS (dBm)<25.7dBm	
826.4	4132	22.58	Pass
836.4	4182	22.69	Pass
846.6	4233	22.78	Pass
1852.4	9262	22.19	Pass
1880.0	9400	22.33	Pass
1907.6	9538	22.44	Pass

SIERRA WIRELESS, INC.

FCC Part 22, 24 / RSS 132, 133	SL9090	May30, 2012	Page 8 of 74
--------------------------------	--------	-------------	--------------

4.4.2.2 *Sub-Test 2*

$\beta_c=12/15$, $\beta_d=15/15$, $\beta_{hs}=24/15$. MPR=0dB translates the min. and max. power limits to 20.3dBm and 25.7dBm respectively.

Frequency (MHz)	Channel	Power (dBm)	Comments
		20.3dBm<Measured RMS (dBm)<25.7dBm	
826.4	4132	22.67	Pass
836.4	4182	22.67	Pass
846.6	4233	22.84	Pass
1852.4	9262	22.28	Pass
1880.0	9400	22.29	Pass
1907.6	9538	22.52	Pass

4.4.2.3 *Sub-Test 3*

$\beta_c=15/15$, $\beta_d=15/8$, $\beta_{hs}=30/15$. MPR=0.5dB translates the min. and max. power limits to 19.8dBm and 25.7dBm respectively.

Frequency (MHz)	Channel	Power (dBm)	Comments
		19.8dBm<Measured RMS (dBm)<25.7dBm	
826.4	4132	22.24	Pass
836.4	4182	22.27	Pass
846.6	4233	22.34	Pass
1852.4	9262	21.74	Pass
1880.0	9400	21.87	Pass
1907.6	9538	22.02	Pass

4.4.2.4 *Sub-Test 4*

$\beta_c=15/15$, $\beta_d=4/15$, $\beta_{hs}=30/15$. MPR=0.5dB translates the min. and max. power limits to 19.8dBm and 25.7dBm respectively.

Frequency (MHz)	Channel	Power (dBm)	Comments
		19.8dBm<Measured RMS (dBm)<25.7dBm	
826.4	4132	22.23	Pass
836.4	4182	22.27	Pass
846.6	4233	22.34	Pass
1852.4	9262	21.81	Pass
1880.0	9400	21.86	Pass
1907.6	9538	22	Pass

SIERRA WIRELESS, INC.

FCC Part 22, 24 / RSS 132, 133	SL9090	May30, 2012	Page 9 of 74
--------------------------------	--------	-------------	--------------

4.4.3 Test 3: RF Output Power Results for HSPA (HSDPA & HSUPA) Rel6

The EUT supports Category 5 FDD E-DCH physical layer. As stated in the 3GPP TS25.306 V7.3.0 Table 5.1g, the details of Category 5 are as follows:

- Maximum of 2 E-DCH transmitted codes
- Minimum spreading factor of SF2
- Support for only 10 ms TTI E-DCH
- Maximum 20000 bits in an E-DCH transport block within a 10 ms E-DCH TTI
- Data rate of 2 Mbps
- Support of QPSK only

A detailed list of all settings used is included in section 4.5.

The following five Sub-Tests were completed according to the test requirements outlined in section 5.2B of the 3GPP TS34.121-1 V7.5.0 specification. All TX RMS and Peak power requirements were met according to table 5.2B.5 and achieved through the outlined test procedure in section 5.2B.4.2. All UE channels and power ratio's are set according to table C11.1.3 in the 3GPP TS34.121-1 V7.5.0 specification. A summary of these settings is illustrated below:

Subtest	Mode	Call Type	RMC (kbps)	HSDPA FRC	Power Class 3 Max Limit dBm	β_c/β_d	β_{hs}	β_{ec}	β_{ed}	CM (db)	MPR (db)
1	HSPA	PS	12.2	H-Set 1 QPSK	24 (+1.7/-5.2 db)	11 /15	22/15	209/225	1309/225	1.0	0.0
2	HSPA	PS	12.2	H-Set 1 QPSK	22 (+3.7/-5.2 db)	6 /15	12/15	12/15	94/75	3.0	2.0
3	HSPA	PS	12.2	H-Set 1 QPSK	23 (+2.7/-5.2 db)	15 /9	30/15	30/15	47/15	2.0	1.0
4	HSPA	PS	12.2	H-Set 1 QPSK	22 (+1.7/-5.2 db)	2/15	4/15	2/15	56/75	3.0	2.0
5	HSPA	PS	12.2	H-Set 1 QPSK	24 (+1.7/-5.2 db)	15/15	30/15	24/15	134/15	1.0	0.0

Note: The recommended HSUPA MPRs are implemented as per following sub-tests.

4.4.3.1 Sub-Test 1:

$\beta_c=11/15$, $\beta_d=15/15$, $\beta_{hs}=22/15$, $\beta_{ec}=209/225$, $\beta_{ed}=1039/225$, AG=20, 1xSF4, E-TFCI=75. MPR=0dB translates the min. and max. power limits to 18.8dBm and 25.7dBm respectively.

Frequency (MHz)	Channel	Power (dBm)	Comments
		18.8dBm<Measured RMS (dBm)<25.7dBm	
826.4	4132	22.44	Pass
836.4	4182	22.25	Pass
846.6	4233	22.39	Pass
1852.4	9262	21.96	Pass
1880.0	9400	21.97	Pass
1907.6	9538	21.92	Pass

SIERRA WIRELESS, INC.

FCC Part 22, 24 / RSS 132, 133	SL9090	May30, 2012	Page 10 of 74
--------------------------------	--------	-------------	---------------

4.4.3.2 Sub-Test 2:

$\beta_c=6/15$, $\beta_d=15/15$, $\beta_{hs}=12/15$, $\beta_{ec}=12/15$, $\beta_{ed}=94/75$, AG=12, 1xSF4, E-TFCI=67. MPR=2dB translates the min. and max. power limits to 16.8dBm and 25.7dBm respectively.

Frequency (MHz)	Channel	Power (dBm)	Comments
		16.8dBm<Measured RMS (dBm)<25.7dBm	
826.4	4132	20.89	Pass
836.4	4182	20.79	Pass
846.6	4233	20.81	Pass
1852.4	9262	20.52	Pass
1880.0	9400	20.61	Pass
1907.6	9538	20.51	Pass

4.4.3.3 Sub-Test 3:

$\beta_c=15/15$, $\beta_d=9/15$, $\beta_{hs}=30/15$, $\beta_{ec}=30/15$, $\beta_{ed}=47/15$, AG=15, 2xSF4. E-TFCI=92, Note: # of Reference E-TFCI=2. MPR=1dB translates the min. and max. power limits to 17.8dBm and 25.7dBm respectively.

Frequency (MHz)	Channel	Power (dBm)	Comments
		17.8dBm<Measured RMS (dBm)<25.7dBm	
826.4	4132	21.85	Pass
836.4	4182	21.77	Pass
846.6	4233	21.82	Pass
1852.4	9262	21.56	Pass
1880.0	9400	21.52	Pass
1907.6	9538	21.48	Pass

4.4.3.4 Sub-Test 4:

$\beta_c=2/15$, $\beta_d=15/15$, $\beta_{hs}=4/15$, $\beta_{ec}=2/15$, $\beta_{ed}=56/75$, AG=17, 1xSF4, E-TFCI=71. MPR=2dB translates the min. and max. power limits to 16.8dBm and 25.7dBm respectively.

Frequency (MHz)	Channel	Power (dBm)	Comments
		16.8dBm<Measured RMS (dBm)<25.7dBm	
826.4	4132	21.02	Pass
836.4	4182	21	Pass
846.6	4233	21.08	Pass
1852.4	9262	20.79	Pass
1880.0	9400	20.87	Pass
1907.6	9538	20.72	Pass

SIERRA WIRELESS, INC.

FCC Part 22, 24 / RSS 132, 133	SL9090	May30, 2012	Page 11 of 74
--------------------------------	--------	-------------	---------------

4.4.3.5 Sub-Test 5:

$\beta_c=15/15$, $\beta_d=15/15$, $\beta_{hs}=30/15$, $\beta_{ec}=24/15$, $\beta_{ed}=134/15$, $AG=21$, $1xSF4$, $E-TFCI=81$.
MPR=0dB translates the min & max power limits to 18.8dBm and 25.7dBm respectively.

Frequency (MHz)	Channel	Power (dBm)	Comments
		18.8dBm<Measured RMS (dBm)<25.7dBm	
826.4	4132	22.56	Pass
836.4	4182	22.69	Pass
846.6	4233	22.59	Pass
1852.4	9262	21.3	Pass
1880.0	9400	21.32	Pass
1907.6	9538	22.17	Pass

4.5 Test Settings for UMTS Mode on CMU200

WCDMA R99 Mode Settings:

UE Power Control Settings

Maximum allowable UE-Power = 24.0 dBm

UL Target Power = 24.0 dBm

Node B Settings

Primary Scrambling Code = 9

Output Channel Power = -51.7 dBm

OCNS = Off

Total Output Power (Ior+Ioc) = -51.7 dBm

RMC Settings

Reference Channel Type: 12.2 kbps Downlink/Uplink

DL DTCH Transport Format: 12.2 kbps

DL Resources in Use: 100 %

UL CRC (Sym. Loop Mode 2): Off

Test Mode: Loop Mode 1

Channel Data Source DTCH: PRBS9

Voice Settings

Voice Source: Echo

Loopback Type: Off

Adaptive Multirate Settings

Active Code Set: Selection A

Codec Mode: 12.2 kbps

Signaling RAB Settings

© 2009 Sierra Wireless, Inc.

The contents of this page are subject to the confidentiality information on page one.

SIERRA WIRELESS, INC.

FCC Part 22, 24 / RSS 132, 133	SL9090	May30, 2012	Page 12 of 74
--------------------------------	--------	-------------	---------------

SRB Cell DCH: 3.4 kbps

BS Down Link Physical Channels Settings

Ior = -51.7 dBm
P-CPICH = -3.3 dB
P-SCH = -8.3 dB
S-SCH = -8.3 dB
P-CCPCH = -5.3 dB
S-CCPCH = -5.3 dB
S-CCPCH Channel Code = 2
PICH = -8.3 dB
PICH Channel Code = 3
AICH = -8.3 dB
AICH Channel Code = 6
DPDCH = -10.3 dB
DPDCH Channel Code = 96
Power Offset (DPCCH/DPDCH) = 0.0 dB
DL DPCH Timing Offset = 0
Secondary Scrambling Code = 0
Secondary Scrambling Code (HSDPA) = 0
HSDPA Channels = On

TPC Settings

Algorithm = 2
TPC Step Size = 1dB
TPC Pattern Setup = Set 1 (All 1, after linked to get maximum power)

HSDPA Mode Settings:

Node B Settings

Primary Scrambling Code = 9
Output Channel Power = -86 dBm
OCNS = Off
Total Output Power (Ior+Ioc) = -86 dBm

Network Settings

Packet Switched Domain = ON

HSDPA Test Mode Settings

Radiobearer Setup = RMC 12.2 kbps + HSPDA
RMC Test Loop = Loop Mode 1 RLC TM

HSDPA HS-DSCH

CQI Feedback Cycle = 4ms
CQI Repetition Factor = 2
ACK/NACK Repetition Factor = 3

© 2009 Sierra Wireless, Inc.

The contents of this page are subject to the confidentiality information on page one.

SIERRA WIRELESS, INC.

FCC Part 22, 24 / RSS 132, 133	SL9090	May30, 2012	Page 13 of 74
--------------------------------	--------	-------------	---------------

UE Category = 8
Channel Configuration Type = FRC
H-Set Selection = H-Set 1 QPSK
RV Coding Sequence {0,2,5,6}

HSDPA Gain Factors are set according to each specific sub-test in table C.10.1.4 of 3GPP TS 34.121.

HSPA Mode Settings:

UE Power Control Settings

Maximum allowable UE-Power = 24.0 dBm
UL Target Power: Set according to each specific sub-test in table 5.2B.5 of 3GPP TS 34.121 less 5db for starting point.

UE Packet Data Gain Factors

Bc and Bd: *
 Δ ACK, Δ NACK, Δ CQI=8

HSUPA

E-DCH Physical Layer Category = 5
E-TFCI Table Index = 1
Minimum Set E-TFCI = 1*
Maximum Channelisation Code: 1xSF4 or 2xSF4*
Initial Service Grant: *

UE Gain Factors

Δ E-DPCCH: *
Number of Reference E-TFCIs: **
Reference E-TFCI's: **
E-TFCI Power offsets: **

Node B Settings

Primary Scrambling Code = 9
Output Channel Power = -86 dBm
OCNS = Off
Total Output Power (Ior+Ioc) = -86 dBm

Paket Switched

DCH Type: HSUPA Test Mode
Data Rate: HSDPA/HSUPA
HSDPA Test Mode Settings
Radiobearer Setup = RMC 12.2kbps + HSDPA
RMC Test Loop = Loop Mode 1 RLC TM

HSDPA HS-DSCH

SIERRA WIRELESS, INC.

FCC Part 22, 24 / RSS 132, 133	SL9090	May30, 2012	Page 14 of 74
--------------------------------	--------	-------------	---------------

CQI Feedback Cycle = 4ms
CQI Repetition Factor = 2
ACK/NACK Repetition Factor = 3
UE Category = 8
Channel Configuration Type = FRC
H-Set Selection = H-Set 1 QPSK
RV Coding Sequence {0,2,5,6}

HSUPA Test Mode Settings

Radiobearer Setup = SRB 3.4 + HSPA

HSUPA Settings

TTI mode: 10ms

E-AGCH

Pattern Length: 1 AG Value: *

Downlink Physical Channels

HSUPA Channels: On

E-AGCH: -6.0db

E-AGCH Chan. Code: 6

E-RGCH/E-HICH: -5.0db

E-RGCH Active: Off

E-RGCH/E-HICH Chan. Code: 6

*Set according to each specific sub-test in table C.11.1.3 of 3GPP TS 34.121.

** Set according to each specific sub-test in table 5.2B.2/3 of 3GPP TS 34.121.

5 Occupied Bandwidth

FCC 2.1049

5.1 Test Procedure

The transmitter output was connected to a spectrum analyzer through a calibrated coaxial cable and a coupler. The occupied bandwidth (defined as the 99% Power Bandwidth) was measured with the spectrum analyzer at low, middle, and high frequencies in each band. The -26dB bandwidth was also measured and recorded.

Test Setup

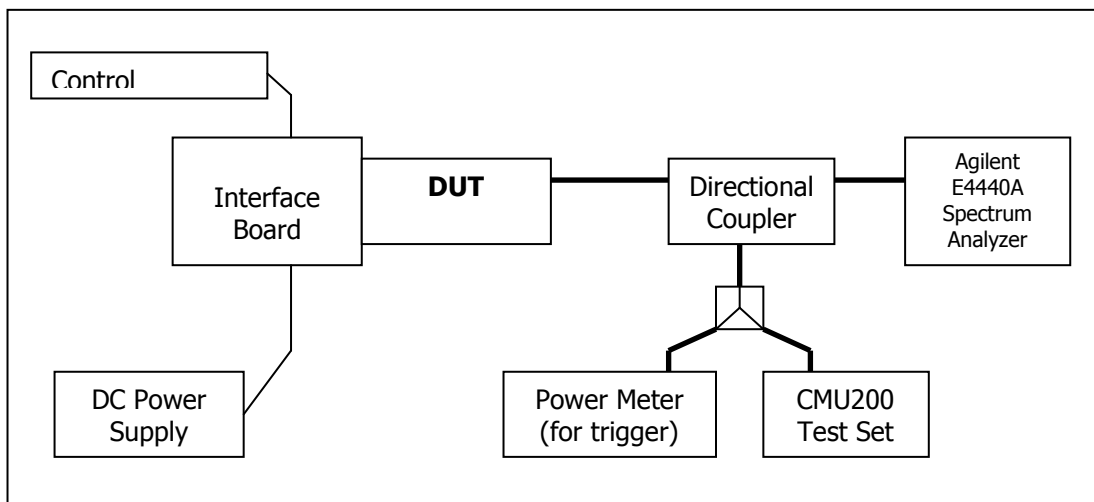

5.2 Test Equipment

EQUIPMENT	MANUFACTURER	MODEL NO.	SERIAL NO.	CAL. DATE
Control Computer	TC	Generic PC	100488	N/A
Wireless Test Set	Rohde & Schwarz	CMU200	117788	November 17, 2011
Spectrum Analyzer	Agilent	E4440A	200078	November 15, 2011
DC Power Supply	HP	6632A	3530A	N/A
Interface Board	Shop built	ATEMux	N/A	N/A
Directional Coupler	Pasternack	PE2209-10	N/A	N/A

5.3 Test Results

The performance of the GSM 850 MHz Cellular band is shown in plots 5.3.1 to 5.3.6.
 Performance of the GSM 1900 MHz PCS band is shown in plots 5.3.7 to 5.3.12.
 Performance of the UMTS 850 Cellular band is shown in plots 5.3.13 to 5.3.15.
 Performance of the UMTS 1900 PCS band is shown in plots 5.3.16 to 5.3.18.

The following GSM test results are based on single slot, and use CS1 for GMSK and MCS9 for 8PSK mode. For WCDMA testing, RMC 12.2kps has been used.

SIERRA WIRELESS, INC.

5.3.1 GSM Results

Frequency (MHz)	Channel	99% Occupied Bandwidth (kHz)		-26dBc Occupied Bandwidth (kHz)	
		GMSK Mode	8-PSK Mode	GMSK Mode	8-PSK Mode
824.2	128	244.39	247.68	309.52	313.50
836.4	189	243.85	242.10	311.70	310.42
848.8	251	243.32	246.60	311.56	308.90
1850.2	512	246.72	240.05	313.55	306.66
1880.0	661	246.08	238.97	315.88	309.84
1909.8	810	248.66	242.51	309.89	307.38

5.3.2 WCDMA Results

Frequency (MHz)	Channel	99% Occupied Bandwidth (MHz)	-26dBc Occupied Bandwidth (MHz)
826.4	4132	4.1279	4.624
836.4	4182	4.1298	4.625
846.6	4233	4.1308	4.619
1852.4	9262	4.1401	4.623
1880.0	9400	4.1240	4.624
1907.6	9538	4.1246	4.620

5.4 Test Plots

5.3.1) GSMK Occupied Bandwidth, Cellular Low channel, 824.2 MHz, 99% BW

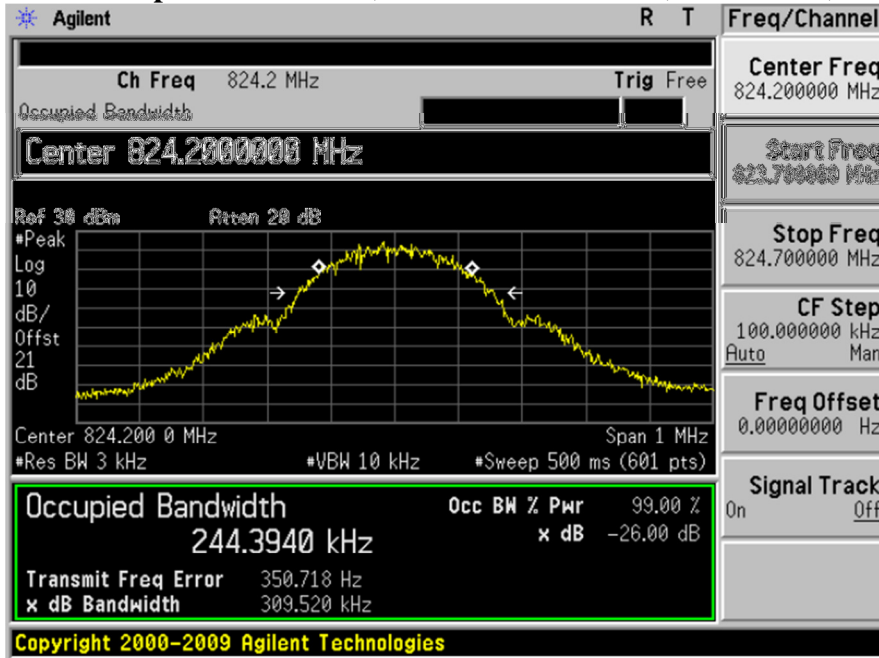

5.3.2) GSMK Occupied Bandwidth, Middle channel, 836.4 MHz, 99% bandwidth

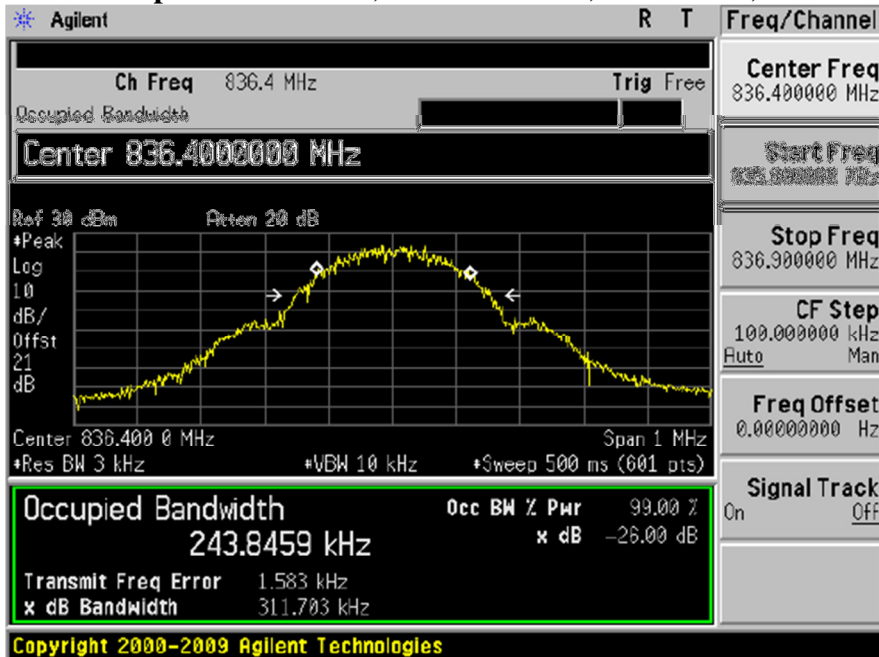

5.3.3) GMSK Occupied Bandwidth, High channel, 848.8 MHz, 99% bandwidth

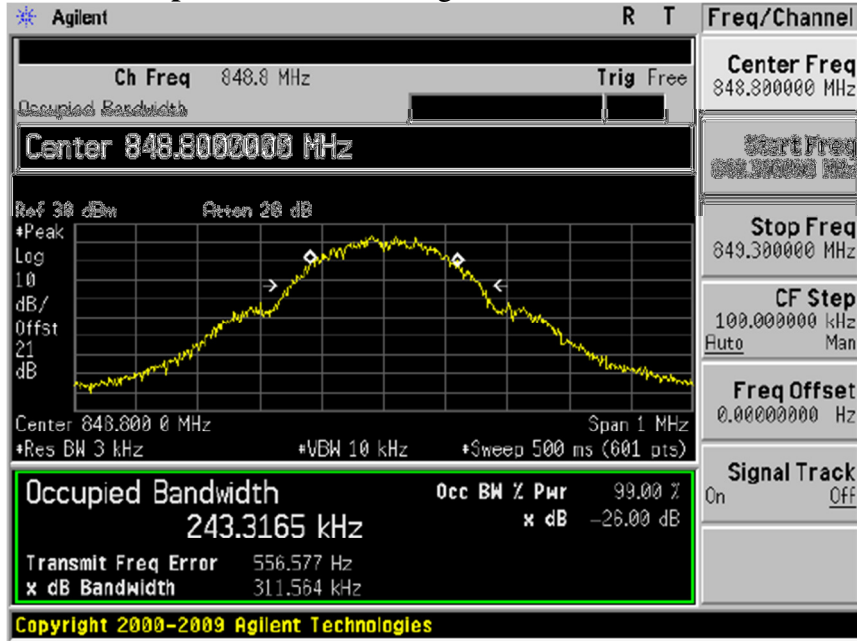

5.3.4) 8-PSK Occupied Bandwidth, Cellular Low channel, 824.2 MHz, 99% BW

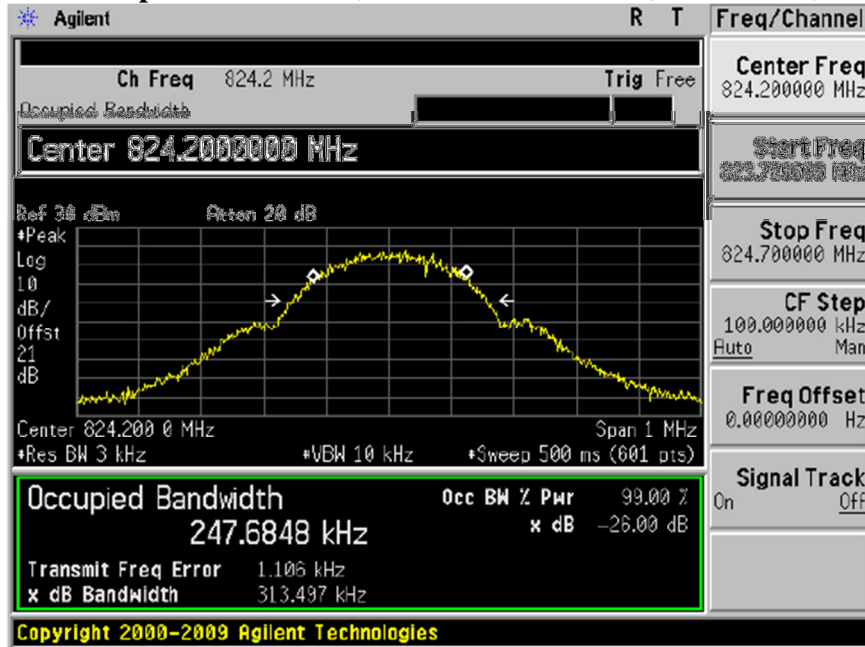

5.3.5) 8-PSK Occupied Bandwidth, Middle channel, 836.4 MHz, 99% bandwidth

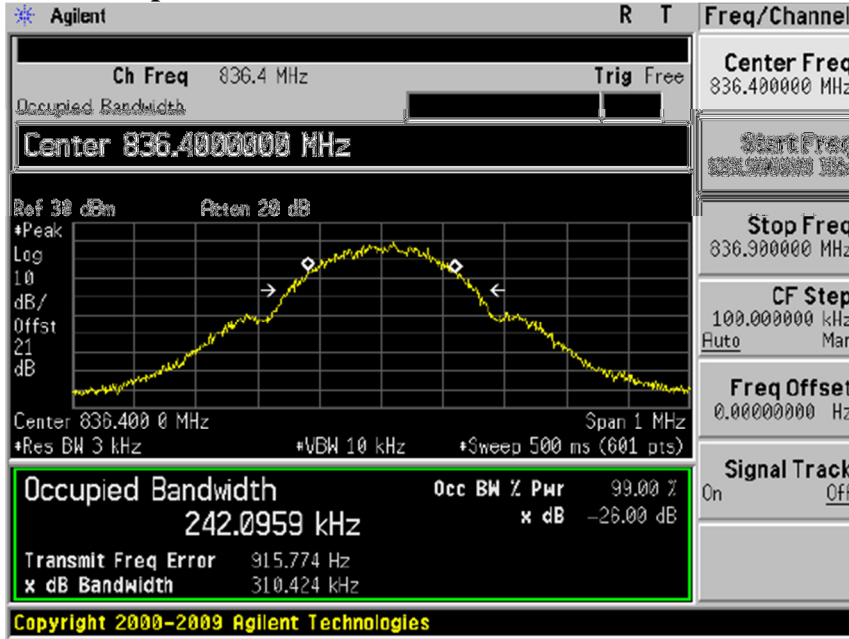

5.3.6) 8-PSK Occupied Bandwidth, High channel, 848.8 MHz, 99% bandwidth

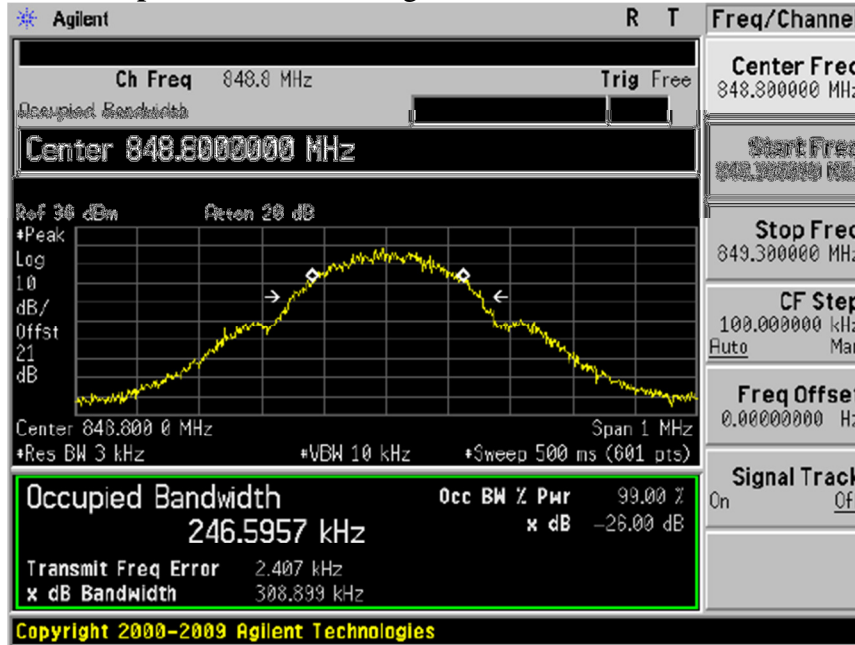

5.3.7) GMSK Occupied Bandwidth, PCS Low channel, 1850.2 MHz, 99% BW

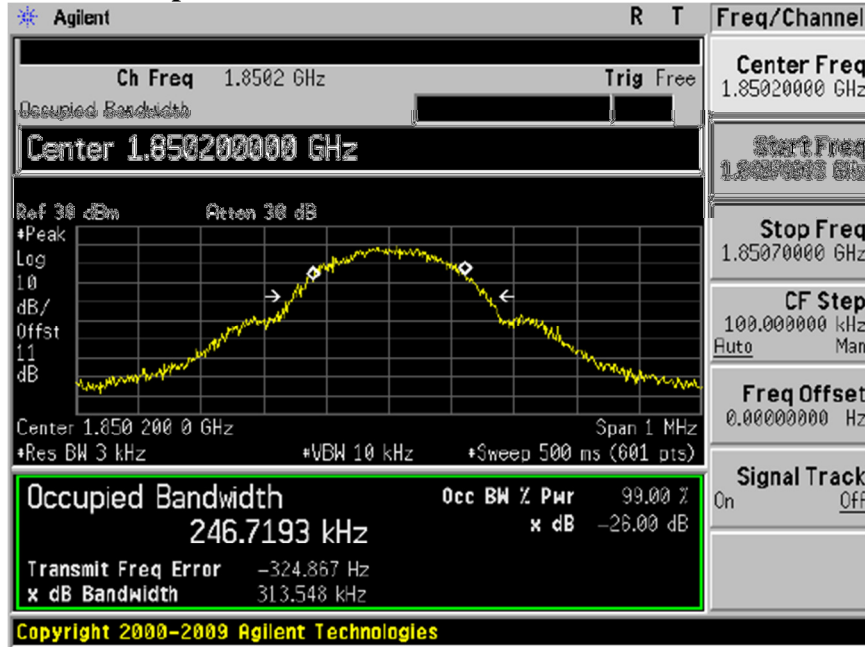

5.3.8) GMSK Occupied Bandwidth, PCS Middle channel, 1880.0 MHz, 99% BW

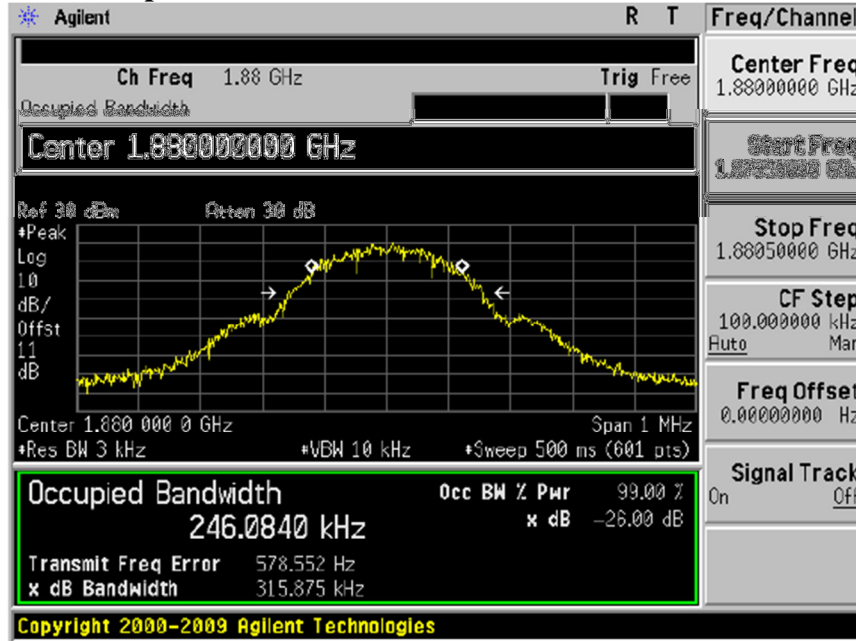

5.3.9) GMSK Occupied Bandwidth, PCS High channel, 1909.8 MHz, 99% BW

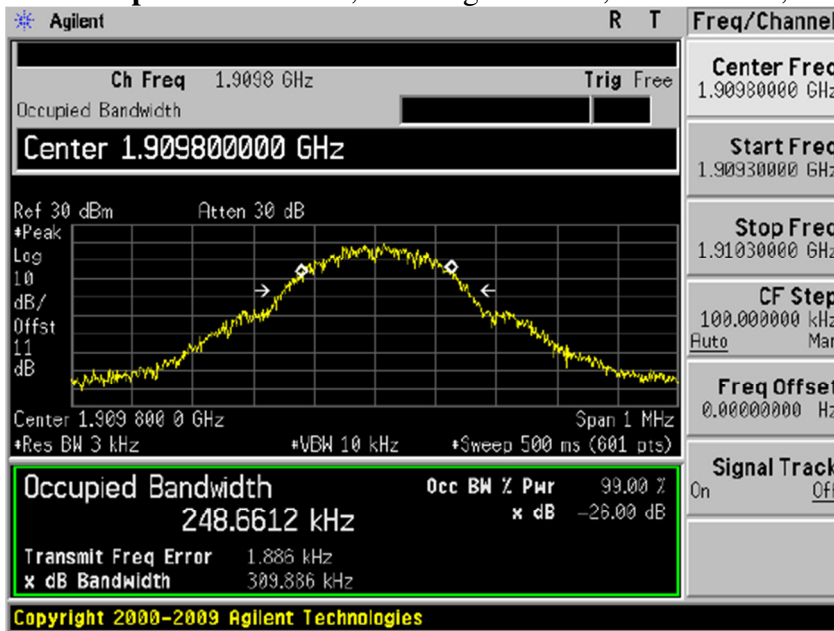

5.3.10) 8-PSK Occupied Bandwidth, PCS Low channel, 1850.2 MHz, 99% BW

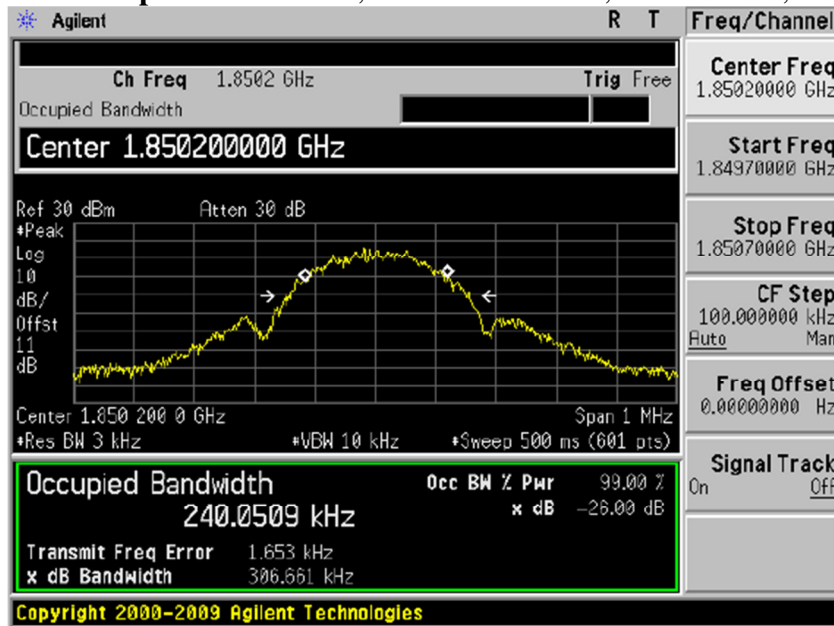

5.3.11) 8-PSK Occupied Bandwidth, PCS Middle channel, 1880.0 MHz, 99% BW

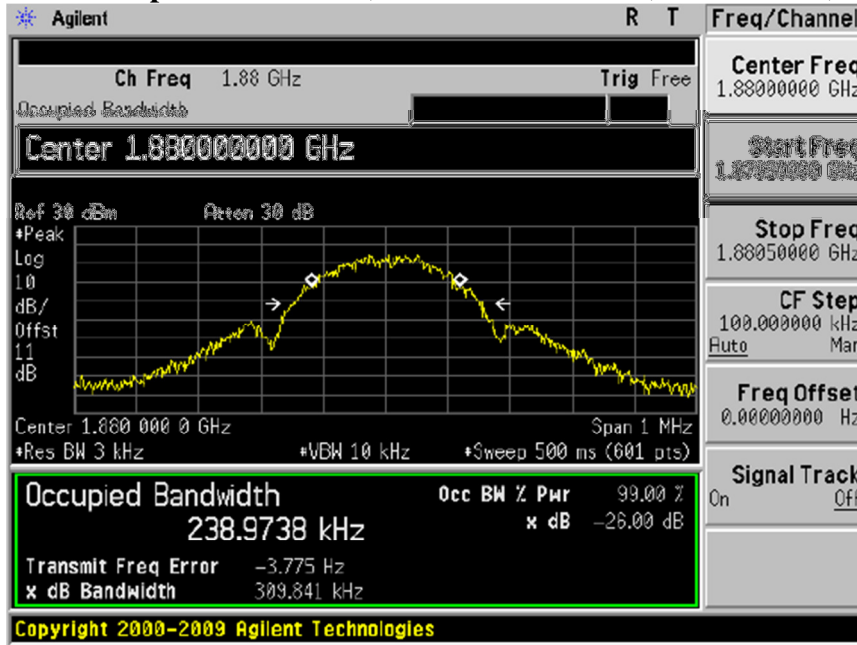

5.3.12) 8-PSK Occupied Bandwidth, PCS High channel, 1909.8 MHz, 99% BW

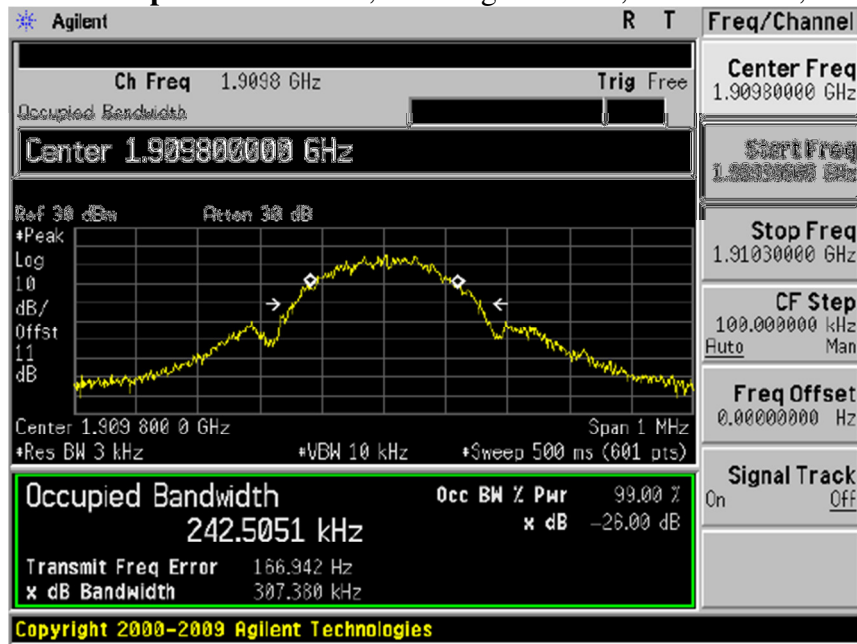

SIERRA WIRELESS, INC.

5.3.13) WCDMA Occupied Bandwidth, Cellular Low channel, 826.4 MHz, 99% BW

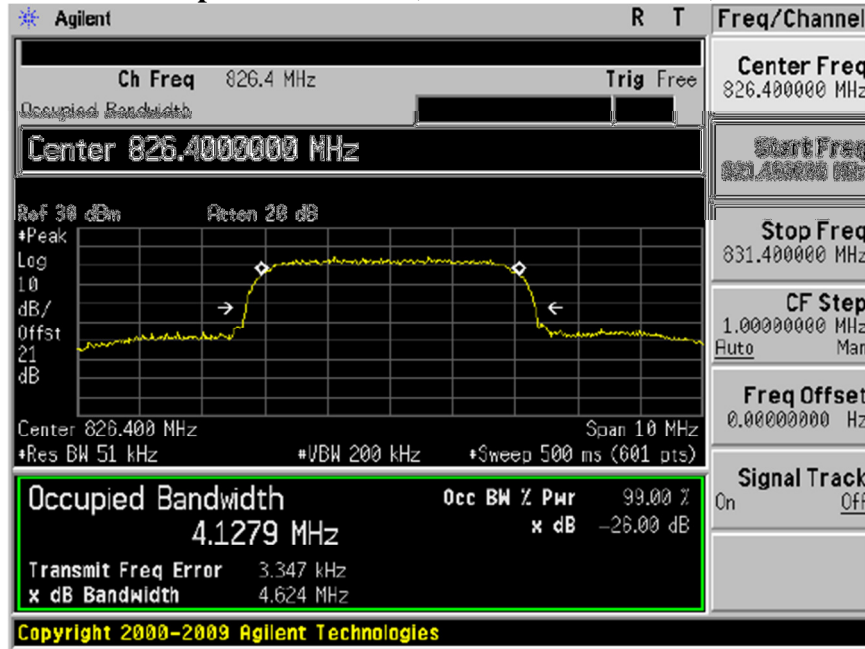

5.3.14) WCDMA Occupied Bandwidth, Cellular Middle channel, 836.4 MHz, 99% BW

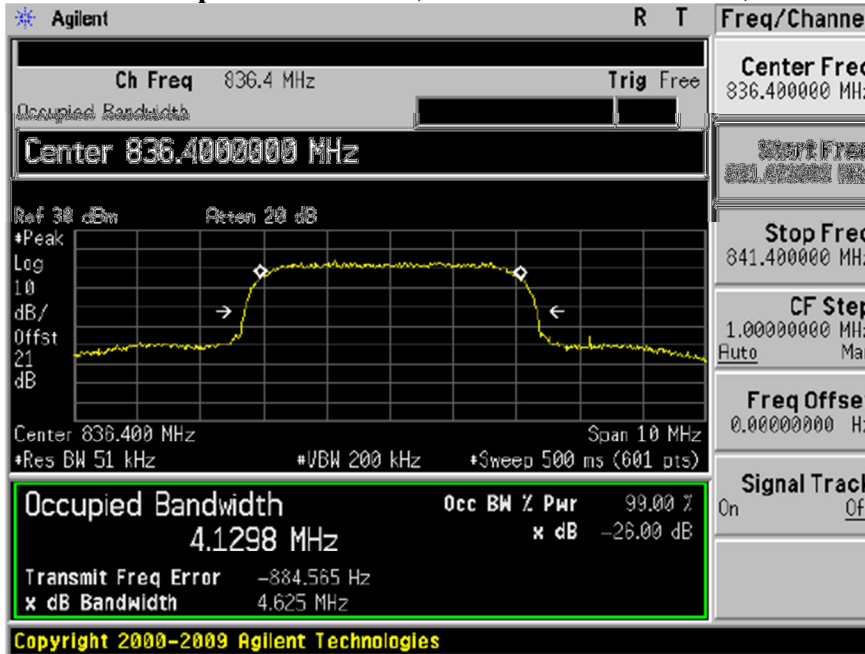

5.3.15) WCDMA Occupied Bandwidth, Cellular High channel, 846.6 MHz, 99% BW

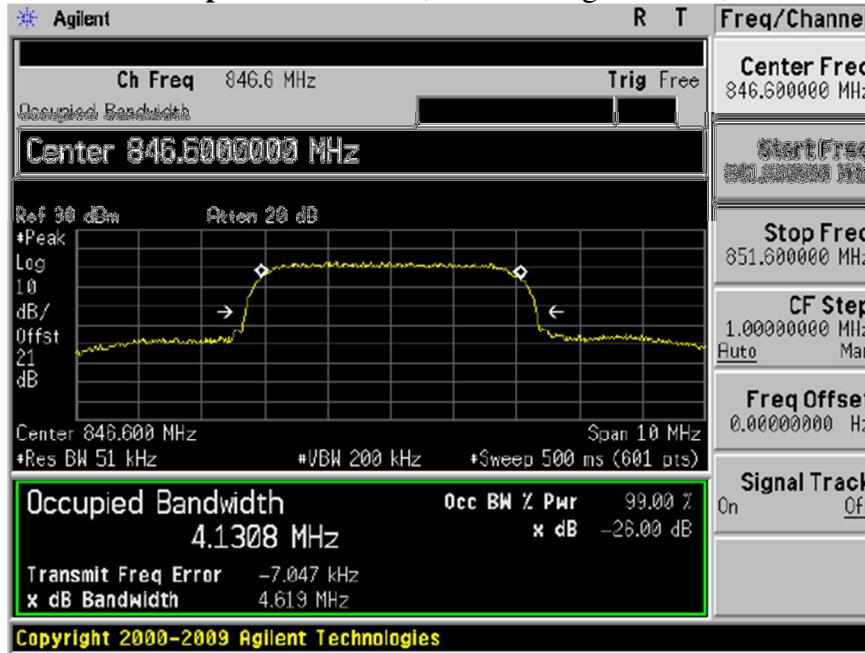

5.3.16) WCDMA Occupied Bandwidth, PCS Low channel, 1852.4 MHz, 99% BW

