

***FCC Part 22 and 24
800/1900 MHz CDMA DUAL BAND MODULE
Model: SB555-S***

FCC ID: N7NSB555

**Prepared by
SIERRA WIRELESS INC.
13811 WIRELESS WAY
RICHMOND, BC V6V 3A4
CANADA**

Test Date(s): September 2002

© 2002 Sierra Wireless, Inc.

This document contains information which is proprietary and confidential to Sierra Wireless, Inc. Disclosure to persons other than the officers, employees, agents, or subcontractors of the Company or licensee of this document without the prior written permission of Sierra Wireless, Inc. is strictly prohibited.

Table of Contents

1 Introduction and Purpose 3

2 Test Summary 3

3 Product Description 4

4 Test Configuration 5

5 RF Power Output 6

 5.1 Test Procedure 6

 5.2 Test Equipment 6

 5.3 Test Results 7

6 Occupied Bandwidth 14

 6.1 Test Procedure 14

 6.2 Test Equipment 14

 6.3 Test Results 14

7 Out of Band Emissions at Antenna Terminals 17

 7.1 Test Procedure 17

 7.2 Test Equipment 17

 7.3 Test Results 18

8 Frequency Stability vs Temperature 40

 8.1 Test Procedure 40

 8.2 Test Equipment 40

 8.3 Test Results 41

9 Frequency Stability vs Voltage 42

 9.1 Test Procedure 42

 9.2 Test Equipment 43

 9.3 Test Results 43

SIERRA WIRELESS, INC.

FCC Part 22 & 24 Test Report	SB555-S	Sept 2002	Page 3 of 43
------------------------------	---------	-----------	--------------

1 Introduction and Purpose

This document provides the FCC test data for the SB555-S module. The tests included in this report are limited to all conducted tests required. Other radiated tests were performed at an external test facility.

2 Test Summary

FCC RULE	DESCRIPTION OF TEST	RESULT	PAGE
2.1046	RF Power Output	Complies	6
2.1049	Occupied Bandwidth	Complies	15
2.1051, 22.901(d) 22.917(f), 24.238(a)	Out of Band Emissions at Antenna Terminals Mobile Emissions In Base Frequency Range	Complies	18
2.1053	Field Strength of Spurious Radiation	Complies	See CCS Report
2.1055	Frequency Stability vs Temperature	Complies	44
2.1055	Frequency Stability vs Voltage	Complies	45

The tests described in this report were performed by Mr. Sean Hoare, under the supervision of Mr Ron Vanderhelm, P.Eng. at

Sierra Wireless, Inc.
13811 Wireless Way
Richmond, B.C. V6V 3A4
Canada

SIERRA WIRELESS, INC.

FCC Part 22 & 24 Test Report	SB555-S	Sept 2002	Page 4 of 43
------------------------------	---------	-----------	--------------

3 Product Description

The Sierra Wireless Inc. model SB555-S is a dual band CDMA embedded modem.

EUT Type	Cellular and PCS CDMA Embedded Modem
Whether quantity(>1) production is planned	<input checked="" type="checkbox"/> Yes <input type="checkbox"/> No
Standards	CDMA2000
Types of Emission	1M25F9W
RF Output Power	824-849 MHz: 23.5 dBm max 1850-1910 MHz: 23.5 dBm max In both bands, power is variable to -50 dBm.
Frequency Range	824-849 MHz, 1850-1910 MHz

SIERRA WIRELESS, INC.

FCC Part 22 & 24 Test Report	SB555-S	Sept 2002	Page 5 of 43
------------------------------	---------	-----------	--------------

4 Test Configuration

Tests were performed on the radio module alone. For frequency stability versus temperature, testing the module requires a wider range of temperature at the higher extreme to account for the insulating and warming affects of the end-user device. We test up to 70 degrees C for the module alone rather than just 50 deg C for the module in the end user device. For the effect of variation of DC power supply on frequency stability, the DC supply to the module was varied to the extremes of its specified voltage range, 3.15 to 4.2 volts.

Item #	Description	Model No.	Serial No.
1	Module EUT	SB555-S	E0207135003503C

5 RF Power Output

FCC 2.1046

5.1 Test Procedure

The transmitter output was connected to an Agilent 8960 CDMA Test Set and configured to operate at maximum power. The power was measured at three equally spaced operating frequencies in each band and was confirmed by the plots taken on the Spectrum Analyzer.

Test Setup

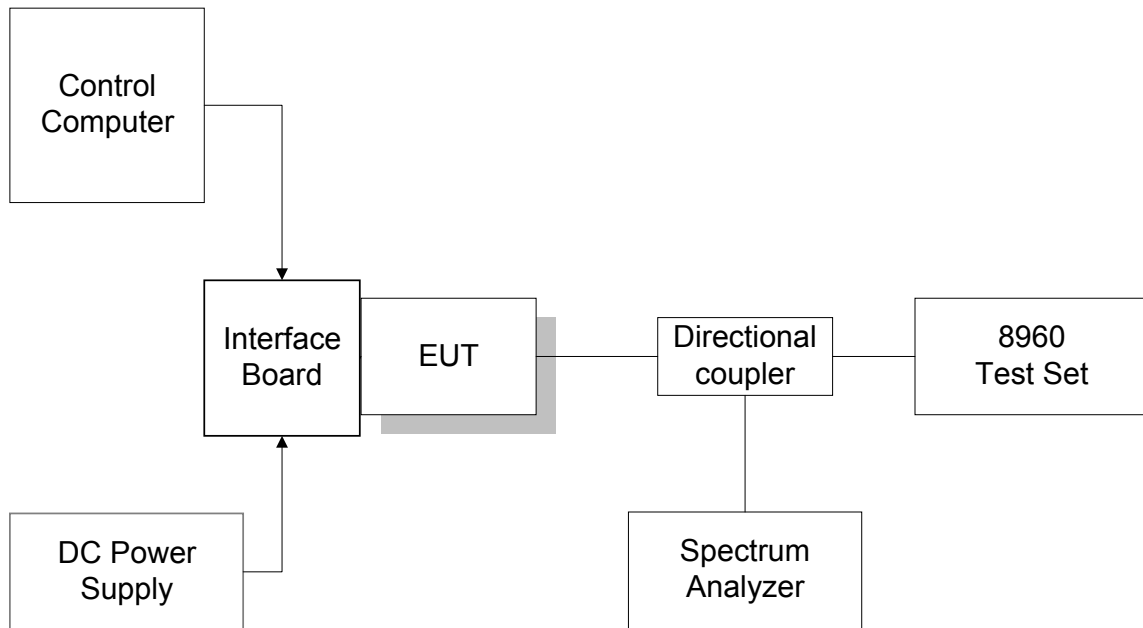

5.2 Test Equipment

Instrument List

EQUIPMENT	MANUFACTURER	MODEL NO.	SERIAL NO.	CAL. DATE
Control Computer	TC	Generic PC	100844	N/A
Wireless Test Set	Agilent	8960	US41070182	09/05/2001
Spectrum Analyzer	Agilent	PSA E4440A	US41421268	2002-01-25
DC Power Supply	HP	HP6632A	3326A-03423	N/A
Interface Board	Shop built	Nest	N/a	N/A
Directional Coupler	Pasternack	PE2209-10	N/A	N/A

SIERRA WIRELESS, INC.

5.3 Test Results

Frequency (MHz)	Power (dBm)
824.70	23.28
836.52	23.50
848.31	23.30
1851.25	23.44
1880.0	23.69
1908.75	23.72

• Cellular Band (CDMA Mode)

Plot Number	Description
1.1	Low Channel (Ch 1013)
1.2	Middle Channel (Ch 384)
1.3	High Channel (Ch 777)

• PCS Band (CDMA Mode)

Plot Number	Description
1.4	Low Channel (Ch 25)
1.5	Middle Channel (Ch 600)
1.6	High Channel (Ch 1175)

The Modem was calibrated to a maximum power of 23.5 dBm.

SIERRA WIRELESS, INC.

FCC Part 22 & 24 Test Report	SB555-S	Sept 2002	Page 8 of 43
------------------------------	---------	-----------	--------------

Plot 1.1 Cellular Band (Low Channel)

* Agilent 16:28:31 Sep 24, 2002

L

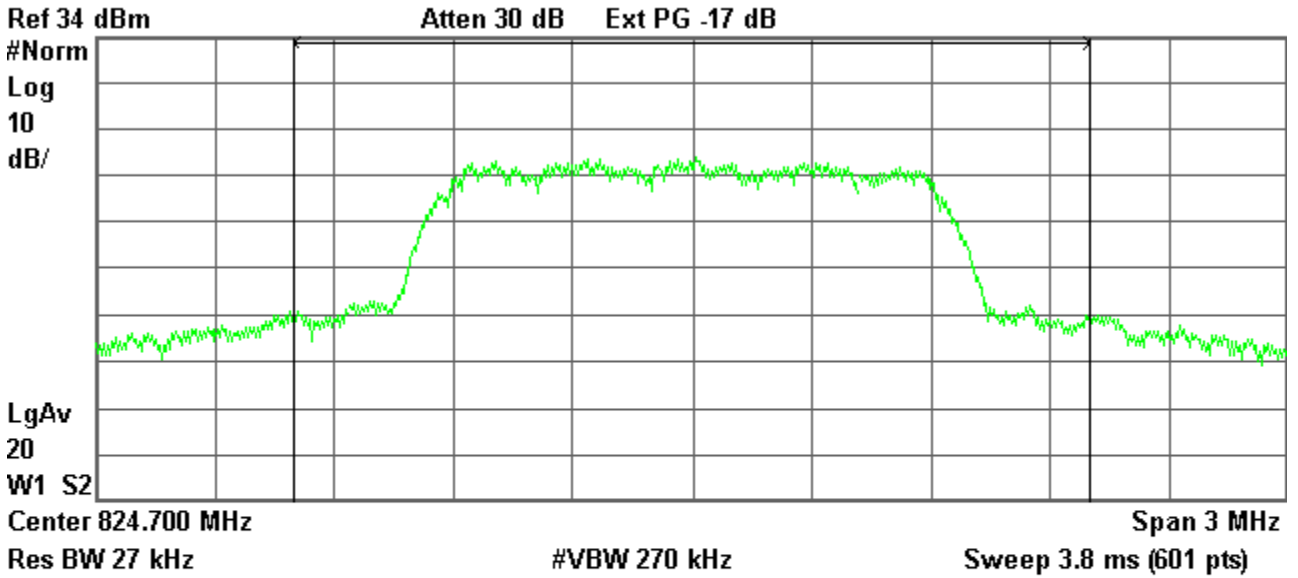

Channel Power

23.28 dBm / 2.0000 MHz

Power Spectral Density

-39.73 dBm/Hz

SIERRA WIRELESS, INC.

FCC Part 22 & 24 Test Report	SB555-S	Sept 2002	Page 9 of 43
------------------------------	---------	-----------	--------------

Plot 1.2 Cellular Band (Middle Channel)

* Agilent 16:29:03 Sep 24, 2002

L

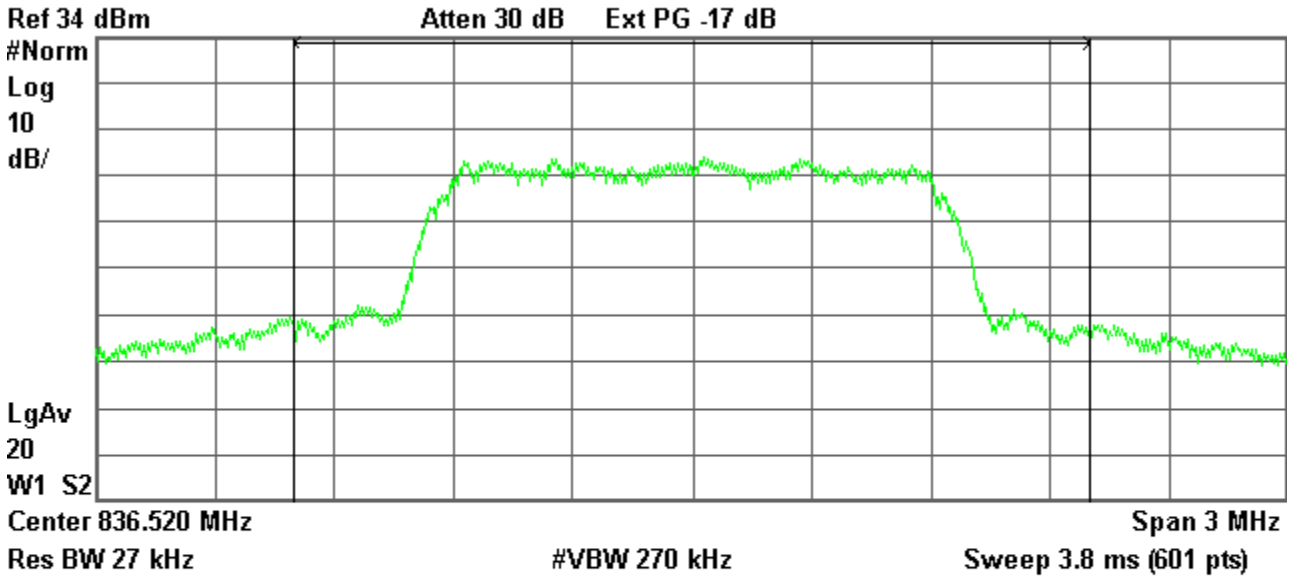

Channel Power

23.50 dBm / 2.0000 MHz

Power Spectral Density

-39.51 dBm/Hz

SIERRA WIRELESS, INC.

Plot 1.3 Cellular Band (High Channel)

* Agilent 16:29:46 Sep 24, 2002

L

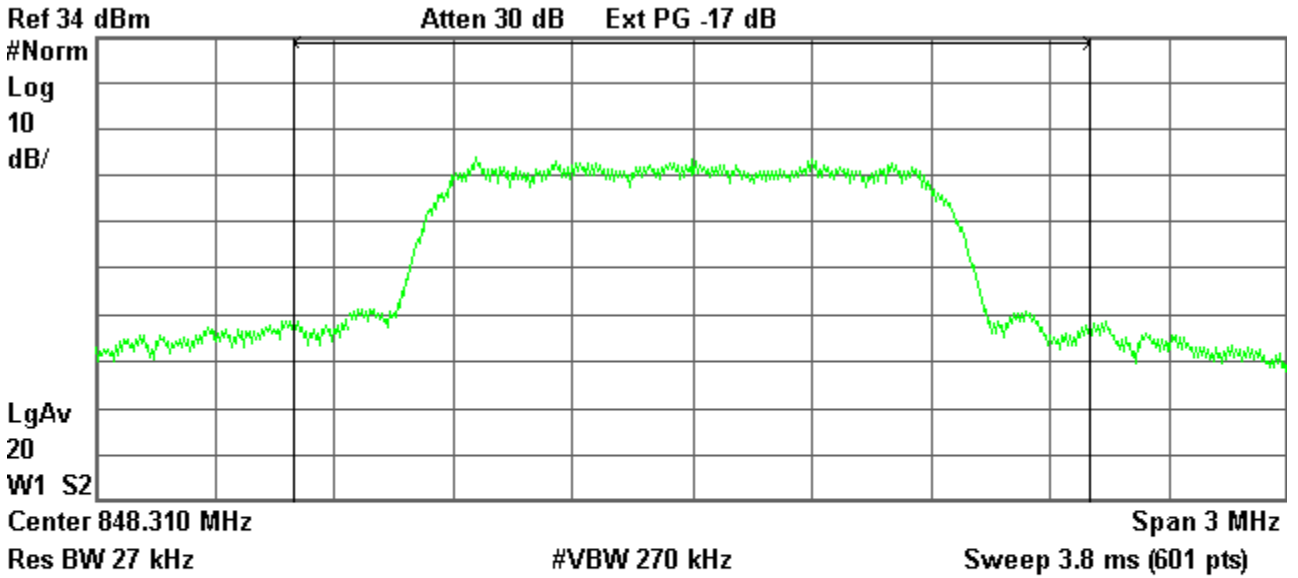

Channel Power

23.30 dBm / 2.0000 MHz

Power Spectral Density

-39.71 dBm/Hz

SIERRA WIRELESS, INC.

Plot 1.4 PCS Band (Low Channel)

* Agilent 16:25:49 Sep 24, 2002

L

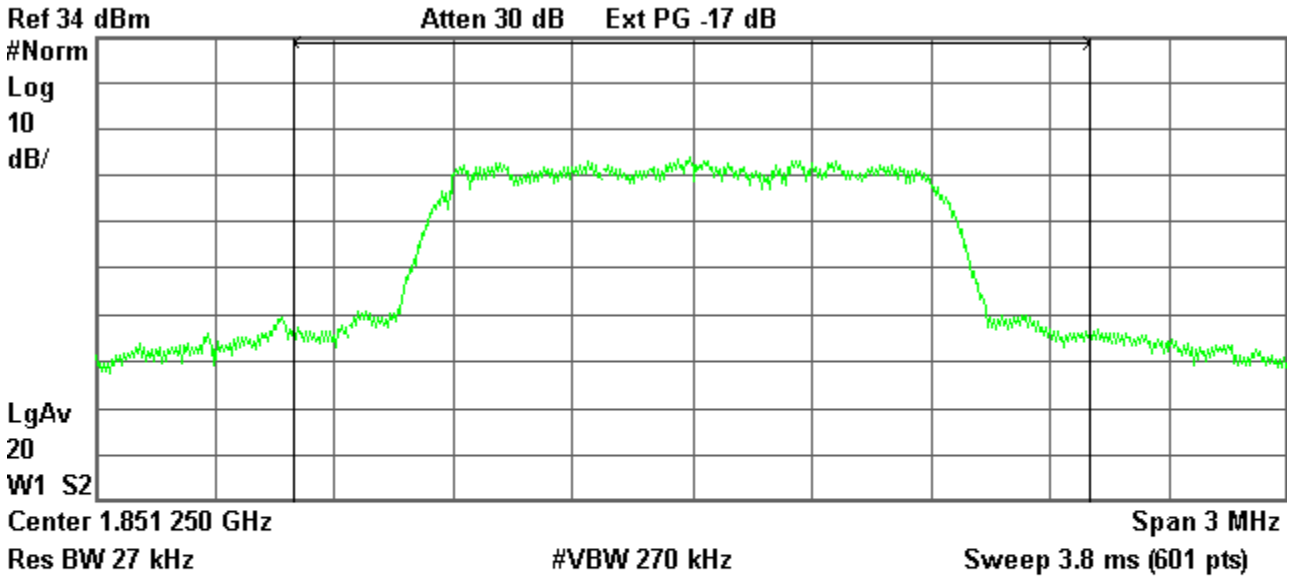

Channel Power

23.44 dBm /2.0000 MHz

Power Spectral Density

-39.57 dBm/Hz

SIERRA WIRELESS, INC.

Plot 1.4 PCS Band (Middle Channel)

* Agilent 16:24:39 Sep 24, 2002

L

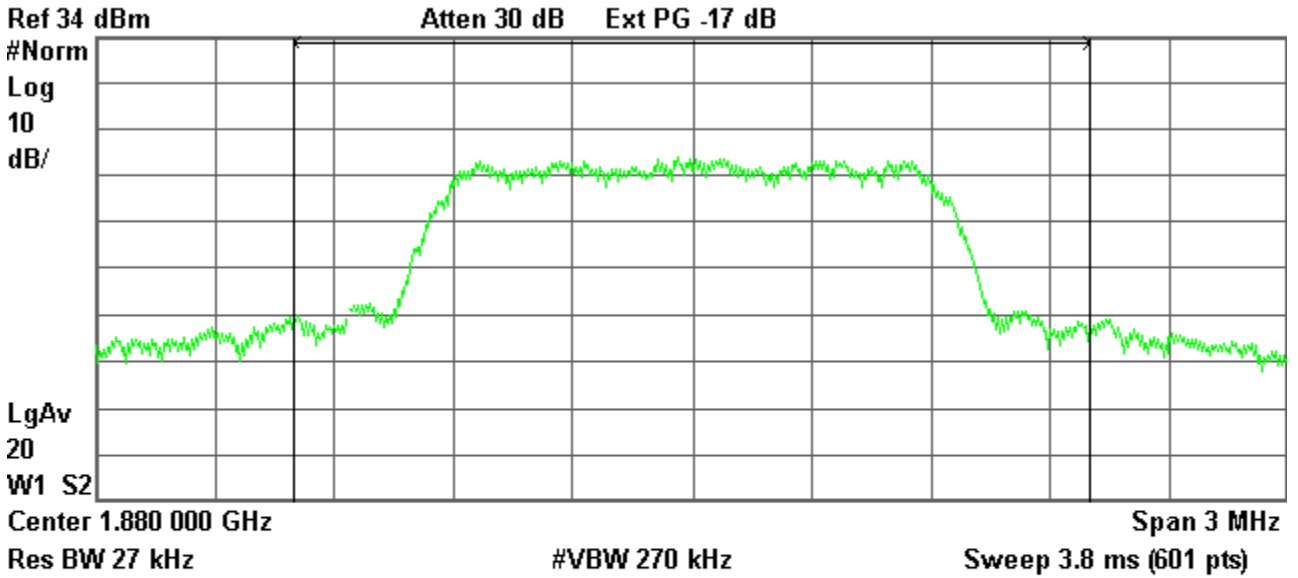

Channel Power

23.69 dBm / 2.0000 MHz

Power Spectral Density

-39.32 dBm/Hz

SIERRA WIRELESS, INC.

Plot 1.4 PCS Band (High Channel)

* Agilent 16:26:50 Sep 24, 2002

L

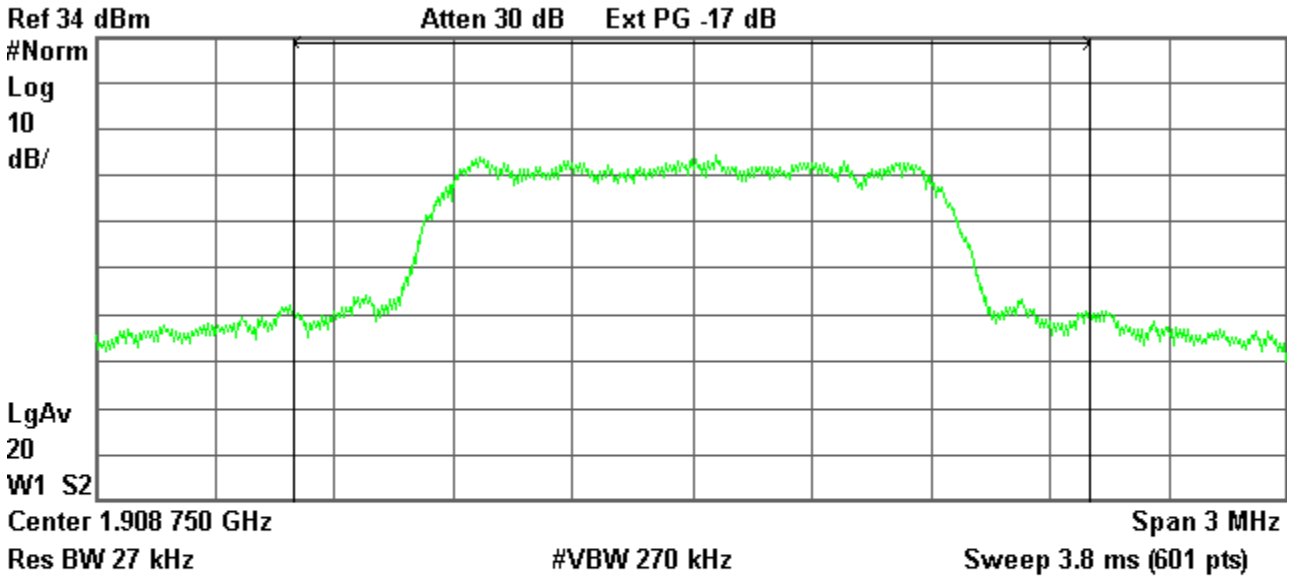

Channel Power

23.72 dBm / 2.0000 MHz

Power Spectral Density

-39.29 dBm/Hz

6 Occupied Bandwidth

FCC 2.1049

6.1 Test Procedure

The transmitter output was connected to a calibrated coaxial cable, the other end of which was connected to a spectrum analyzer. The occupied Bandwidth (defined as the 99% Power Bandwidth) was measured with the Spectrum Analyzer at the center frequency of each band.

Test Setup

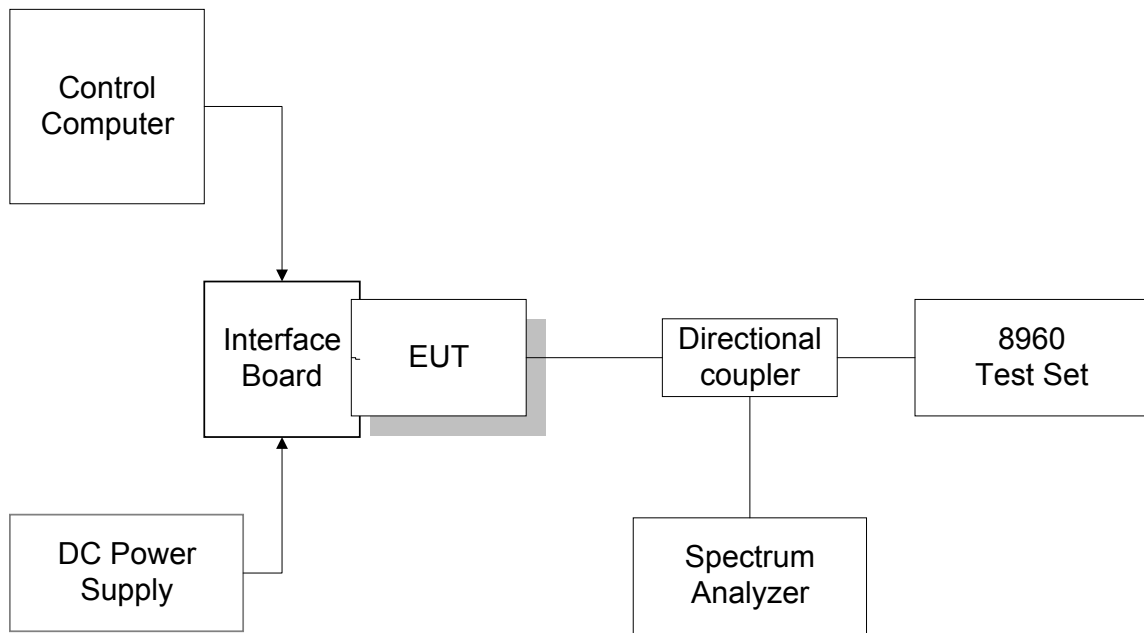

6.2 Test Equipment

EQUIPMENT	MANUFACTURER	MODEL NO.	SERIAL NO.	Last CAL.DATE
Spectrum Analyzer	Agilent	PSA E4440A	US41421268	2002-01-25
Interface Board	Shop built	Nest	N/a	N/a
Control Computer	TC	Generic PC	100844	N/a
DC Power Supply	HP	HP6632A	3326A-03423	N/a

6.3 Test Results

The performance of 800 MHz cellular band is shown in plots 2.1.
 Performance of 1900 MHz PCS band is shown in plots 2.3.

The test results shows that the bandwidth in all cases is approximately 1.270 MHz.

SIERRA WIRELESS, INC.

Plot 2.1 Cellular Band (Middle Channel)

Agilent 12:53:44 Sep 24, 2002

L

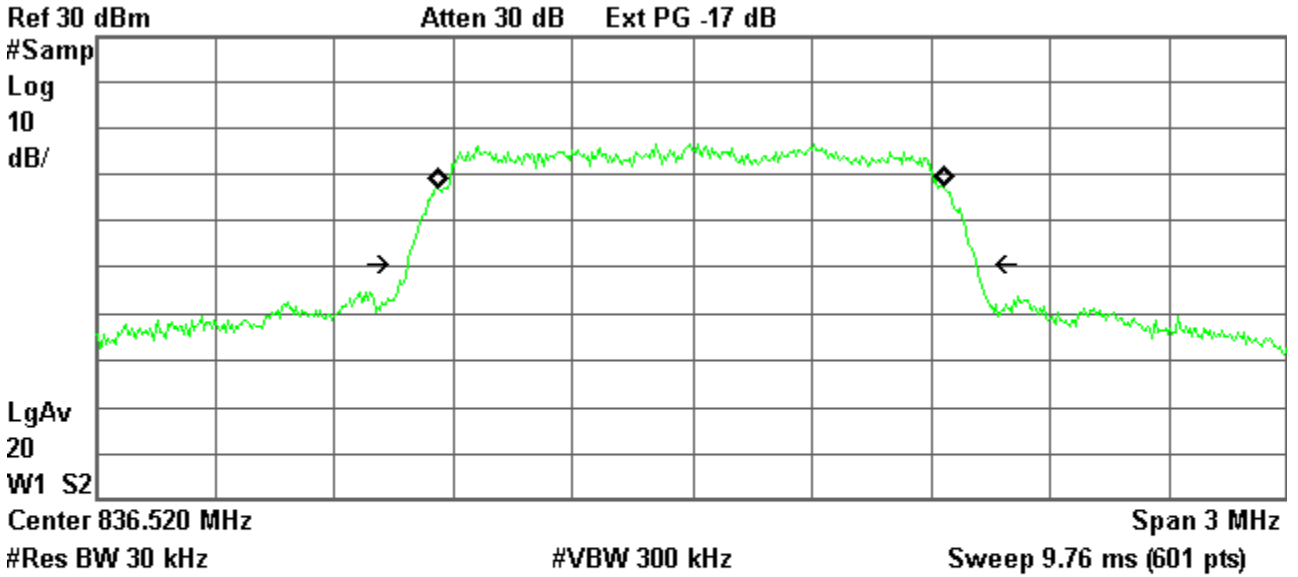

Occupied Bandwidth
1.2726 MHz

Occ BW % Pwr	99.00 %
x dB	-26.00 dB

Transmit Freq Error	-1.760 kHz
x dB Bandwidth	1.432 MHz*

SIERRA WIRELESS, INC.

Plot 2.2 PCS Band (Middle Channel)

Agilent 12:54:22 Sep 24, 2002

L

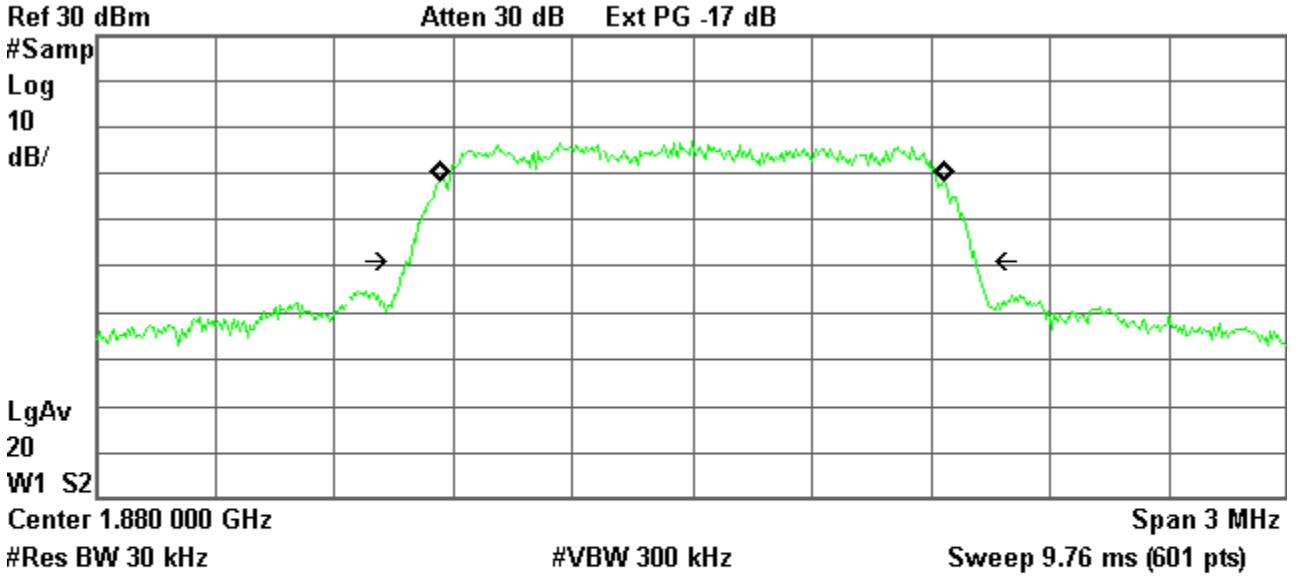

Occupied Bandwidth
1.2716 MHz

Occ BW % Pwr 99.00 %
x dB -26.00 dB

Transmit Freq Error -106.709 Hz
x dB Bandwidth 1.434 MHz*

7 Out of Band Emissions at Antenna Terminals

FCC 22.901(d), 22.917(f), 24.238(a)

Out of Band Emissions:

The mean power of emissions must be attenuated below the mean power of the unmodulated carrier (P) on any frequency outside the frequency band by at least $(43 + 10 \log P)$ dB, in this case, -13dBm.

Mobile Emissions in Base Frequency Range:

The mean power of any emissions appearing in the base station frequency range from cellular mobile transmitters operated must be attenuated to a level not exceed -80 dBm at the transmit antenna connector.

7.1 Test Procedure

The RF output of the transmitter was connected to a spectrum analyzer through a calibrated coaxial cable. Sufficient scans were taken to show the out-of-band Emissions, if any, up to 10th harmonic. The EUT was scanned for spurious emissions from 1MHz to 20GHz with sufficient bandwidth and video resolution. Data plots are included.

Test Setup

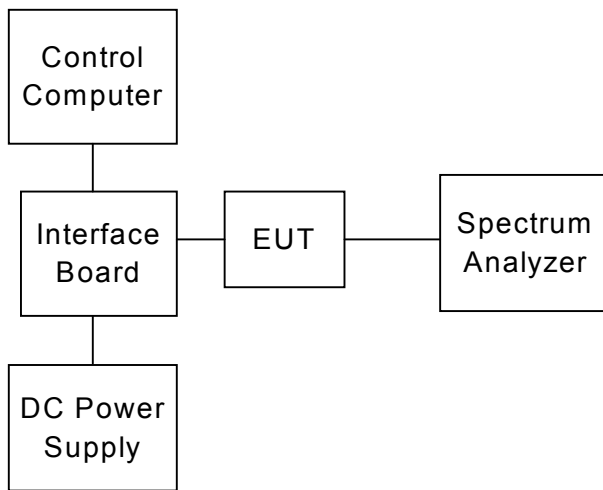

7.2 Test Equipment

EQUIPMENT	MANUFACTURER	MODEL NO.	SERIAL NO.	Last CAL. DATE
Spectrum Analyzer	Agilent	PSA E4440A	US41421268	2002-01-25
Interface Board	Shop built	Nest	N/a	N/a
Control Computer	TC	Generic PC	100844	N/a
DC Power Supply	HP	HP6632A	3326A-03423	N/a
Directional Coupler	Pasternack	PE2209-10	N/A	N/A

SIERRA WIRELESS, INC.

7.3 Test Results

Refer to the following plots.

- **Cellular Band**

Plot Number	Description
3.1a – 3.1c	Low channel, 824.70 MHz
3.2a – 3.2c	Middle Channel, 836.52 MHz
3.3a – 3.3c	High Channel, 848.31 MHz

- **PCS Band**

Plot Number	Description
3.4a – 3.4c	Low Channel, 1851.25 MHz
3.5a – 3.5c	Middle Channel, 1880 MHz
3.6a – 3.6c	High Channel, 1908.75 MHz

- **Emissions in Base Station Frequency Range, Cellular band**

Plot Number	Description
3.7a	Low Channel, 824.70 MHz,
3.8a	Middle Channel, 836.52 MHz
3.9a	High Channel, 848.31 MHz

These plots show that the radiated emission limits requirements are met.

SIERRA WIRELESS, INC.

Plot 3.1a Out of Band Emissions at Antenna Terminals

Low channel, 824.700 MHz,
1 Mhz to 1 GHz

✱ Agilent 17:34:57 Sep 18, 2002

L

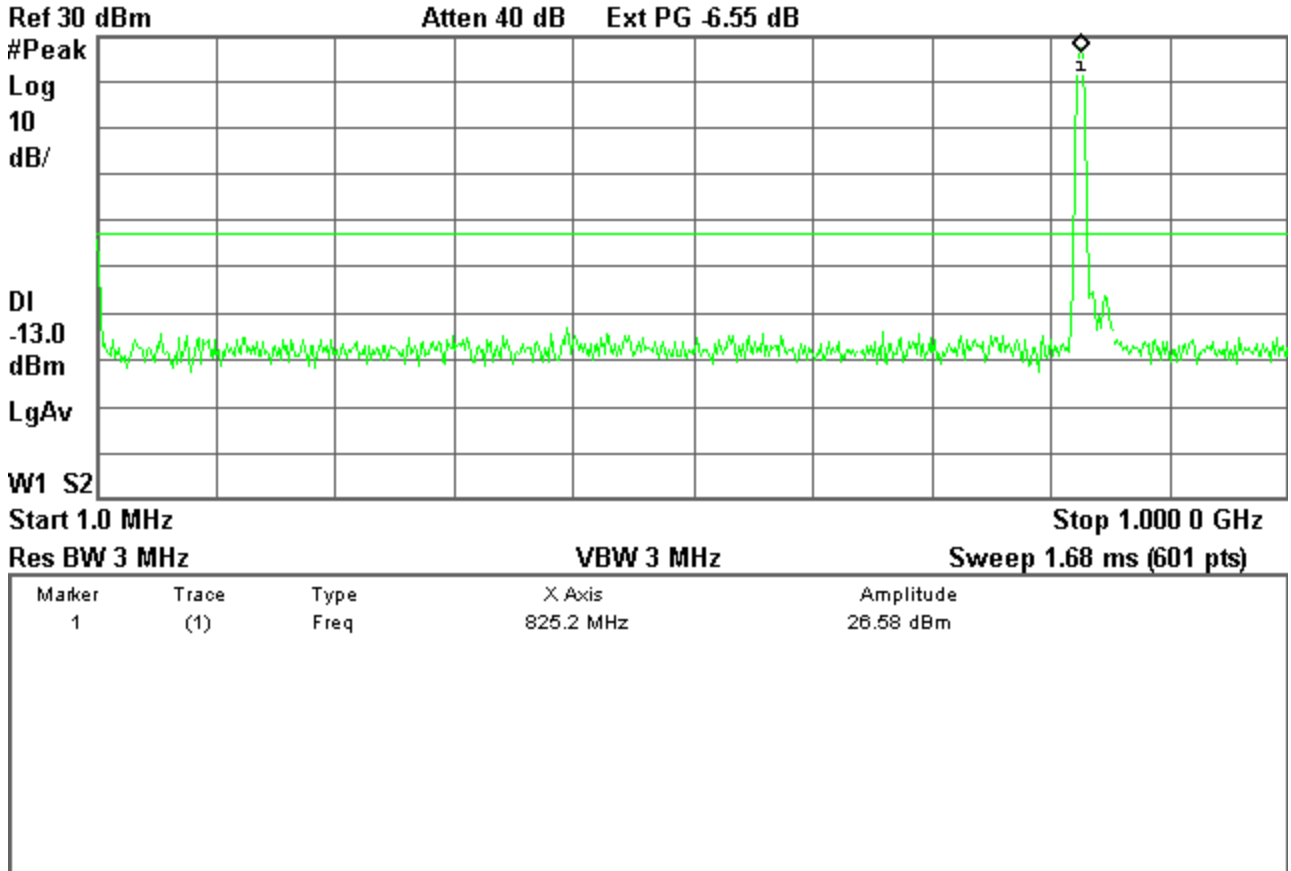

SIERRA WIRELESS, INC.

Plot 3.1b Out of Band Emissions at Antenna Terminals

Low channel, 824.700 MHz

TX signal +/- 20 MHz

Agilent 17:38:19 Sep 18, 2002

L

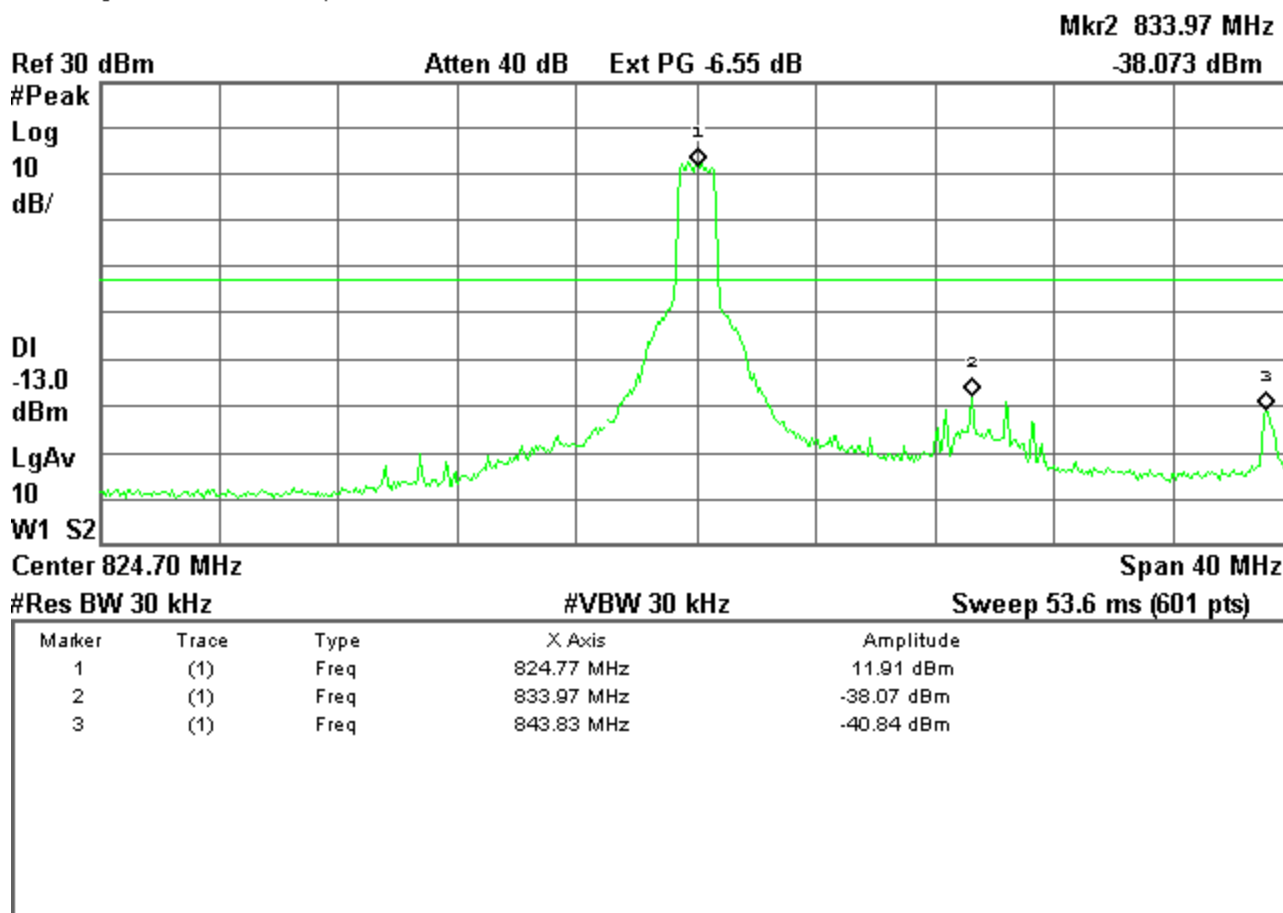

SIERRA WIRELESS, INC.

Plot 3.1c Out of Band Emissions at Antenna Terminals

Low channel, 824.700 MHz

1 GHz to 20 GHz

Agilent 17:49:33 Sep 18, 2002

L

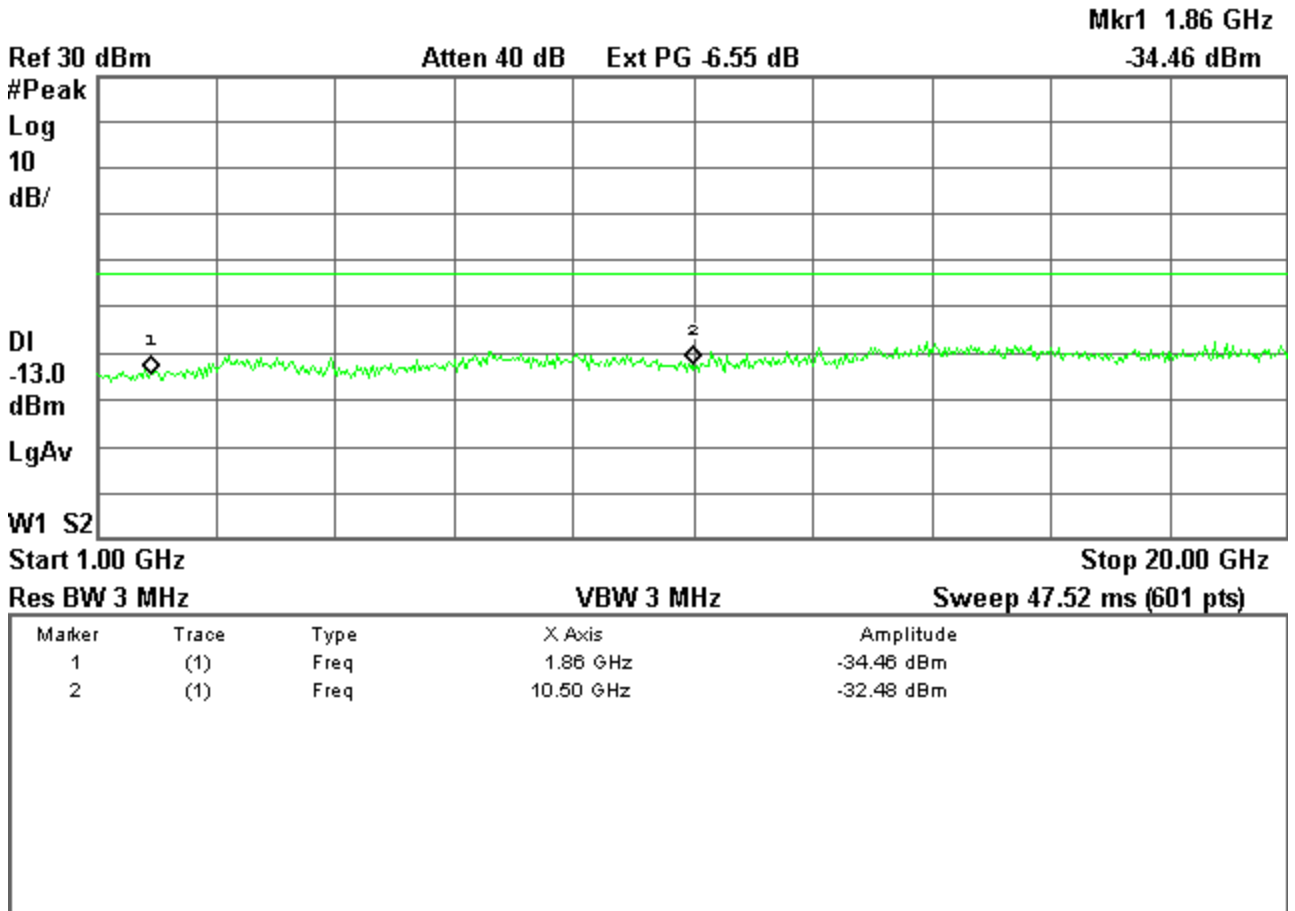

SIERRA WIRELESS, INC.

Plot 3.2a Out of Band Emissions at Antenna Terminals

Mid Channel, 836.52 MHz

1 MHz to 1 GHz

Agilent 17:35:26 Sep 18, 2002

L

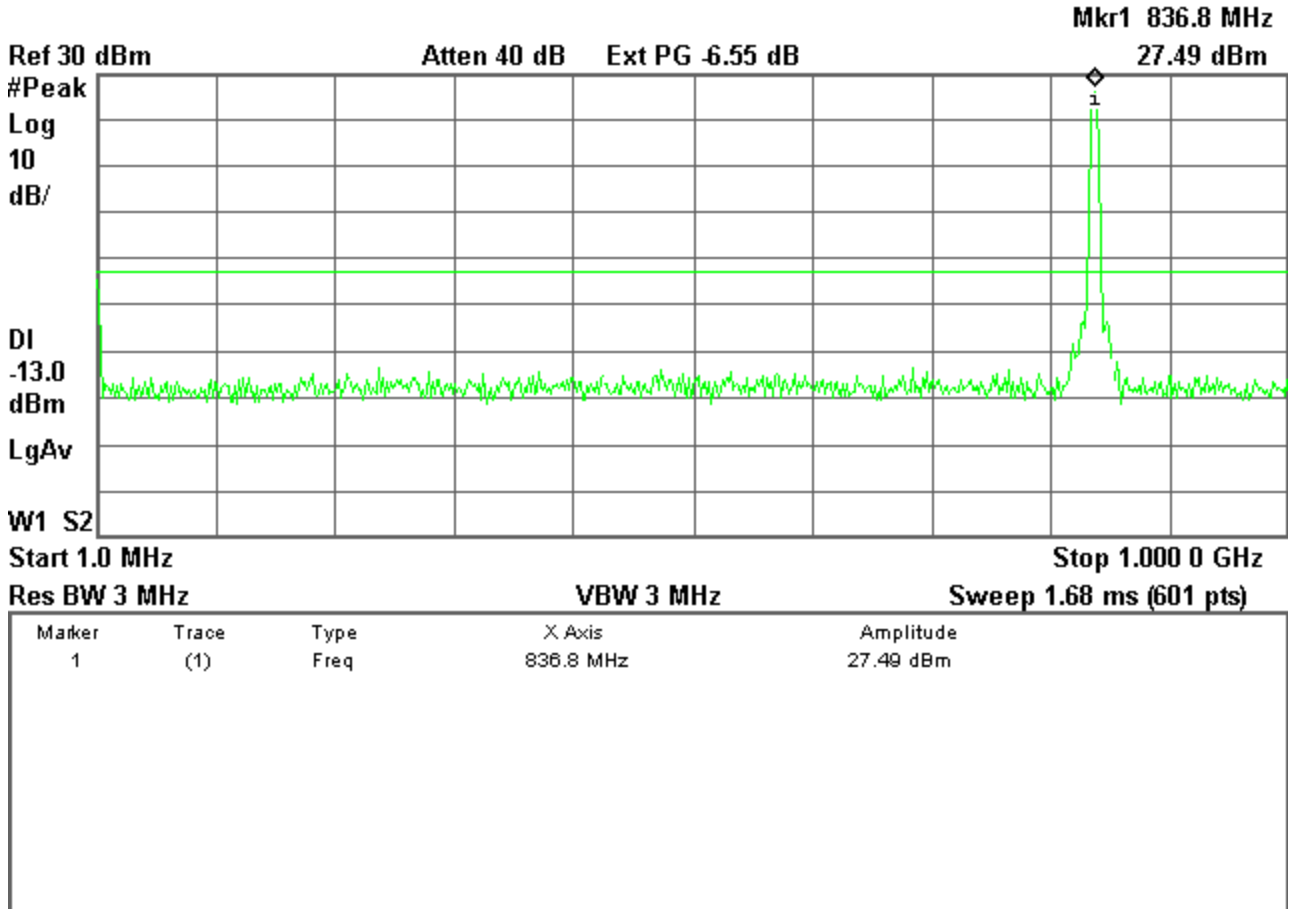

SIERRA WIRELESS, INC.

Plot 3.2b Out of Band Emissions at Antenna Terminals

Mid Channel, 836.52 MHz

TX signal +/- 20 MHz

Agilent 17:39:31 Sep 18, 2002

L

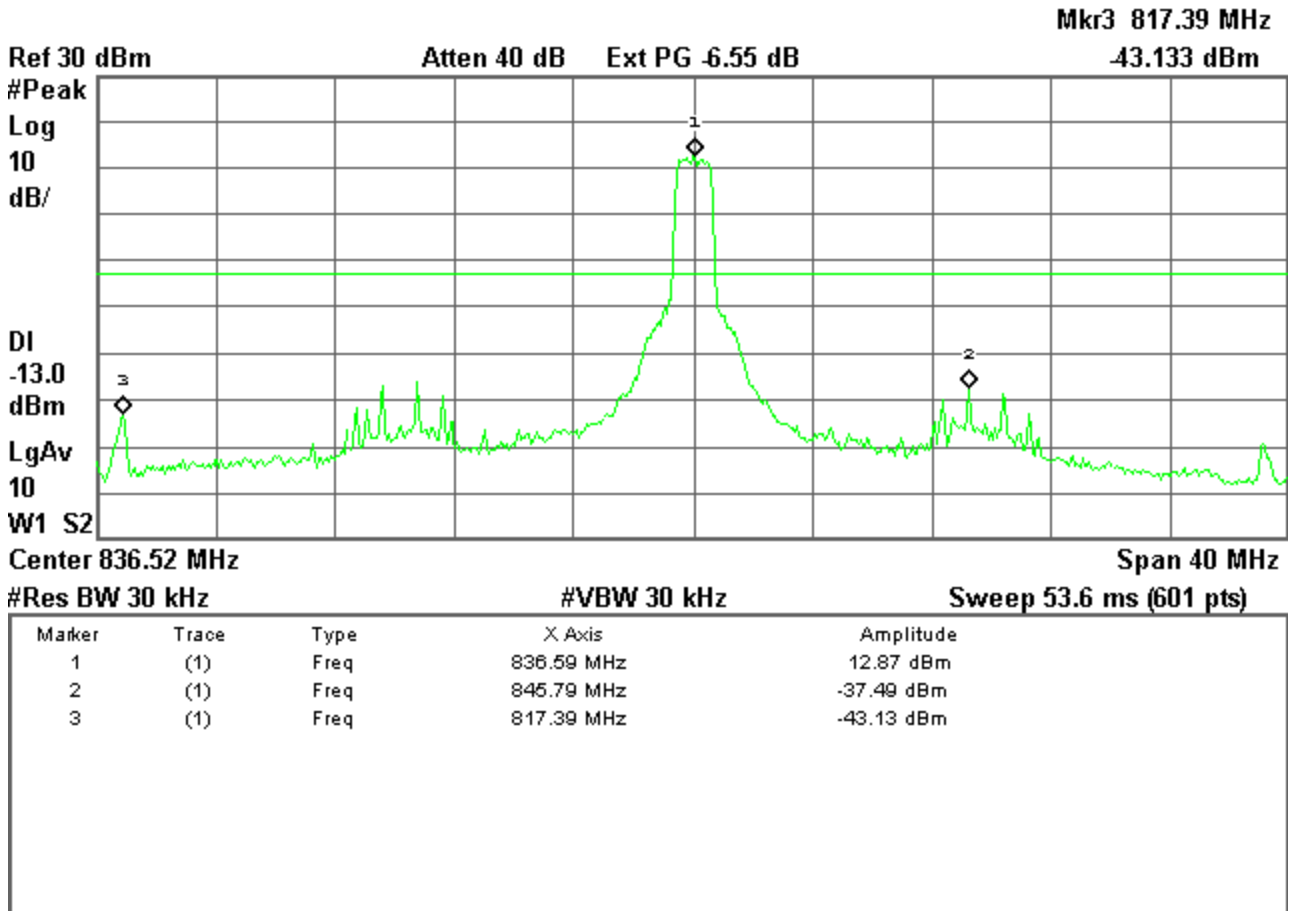

SIERRA WIRELESS, INC.

Plot 3.3a Out of Band Emissions at Antenna Terminals

High Channel, 848.31 MHz

1 Mhz to 1 GHz

Agilent 17:35:54 Sep 18, 2002

L

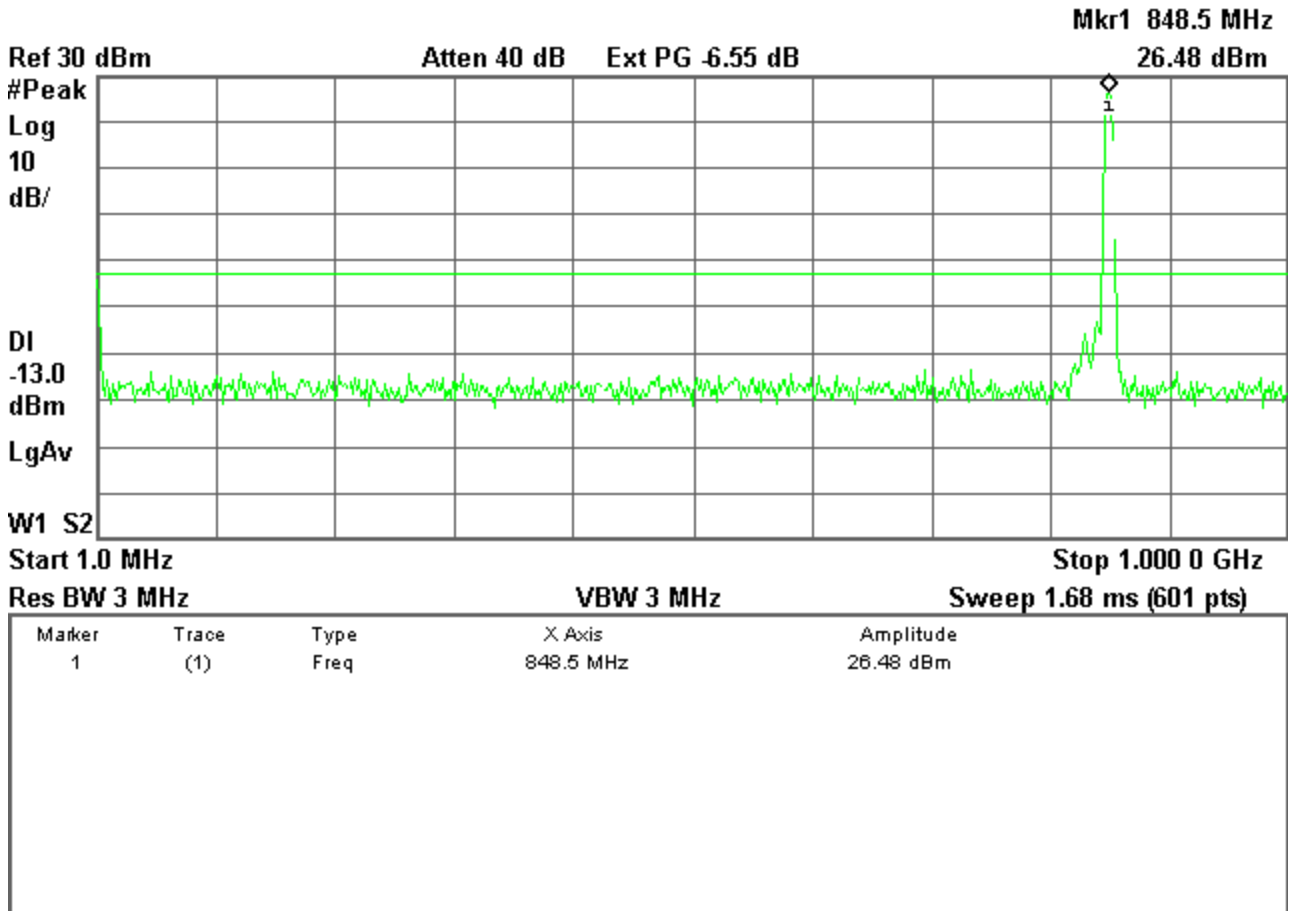

SIERRA WIRELESS, INC.

Plot 3.3b Out of Band Emissions at Antenna Terminals

High Channel, 848.31 MHz

TX signal +/- 20 MHz

Agilent 17:40:22 Sep 18, 2002

L

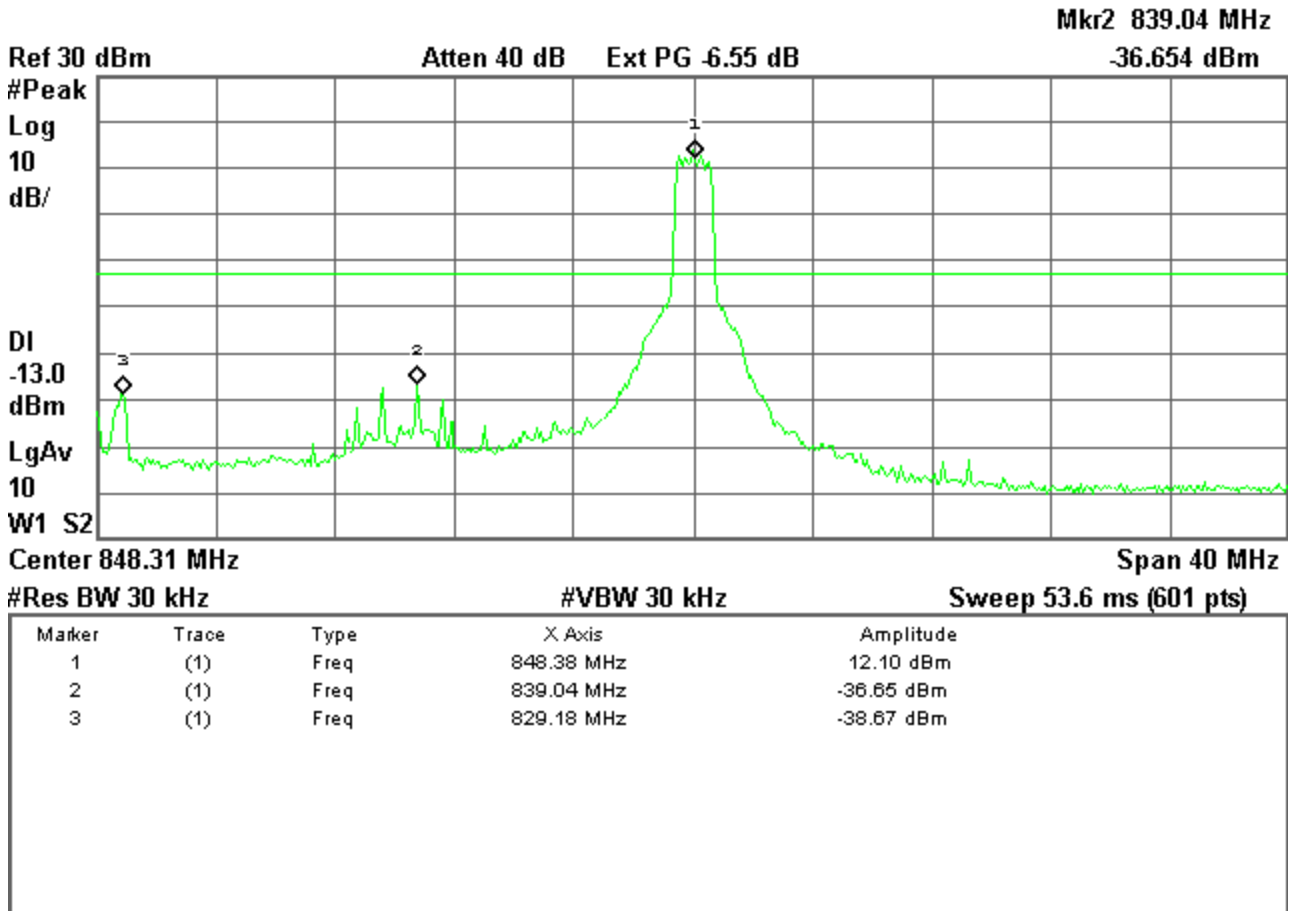

SIERRA WIRELESS, INC.

Plot 3.3c Out of Band Emissions at Antenna Terminals

High Channel, 848.31 MHz

1 GHz to 20 GHz

Agilent 17:49:09 Sep 18, 2002

L

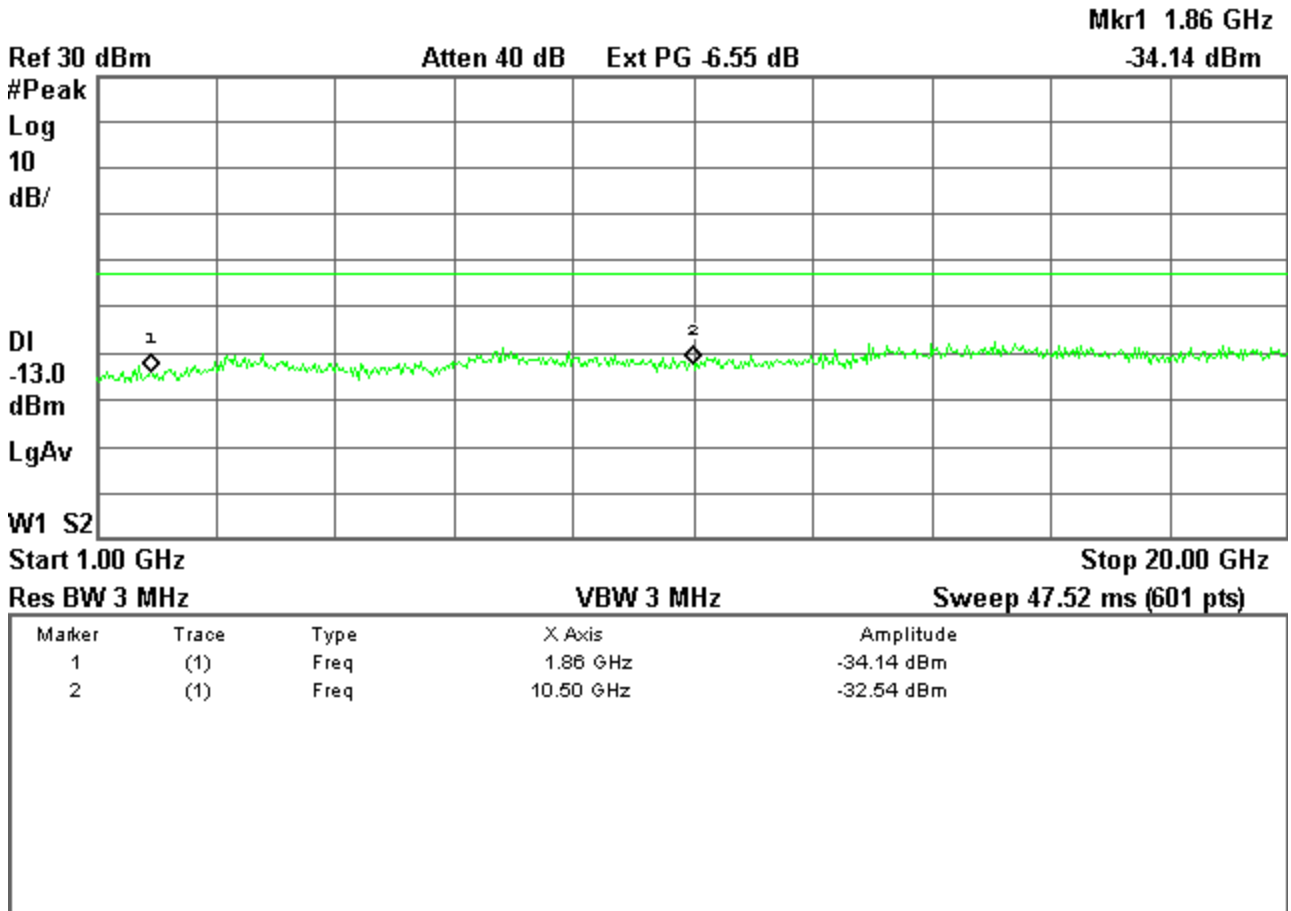

SIERRA WIRELESS, INC.

Plot 3.4a Out of Band Emissions at Antenna Terminals

Low channel, 1851.25 MHz

1 Mhz to 1 GHz

Agilent 17:36:19 Sep 18, 2002

L

Mkr1 848.5 MHz

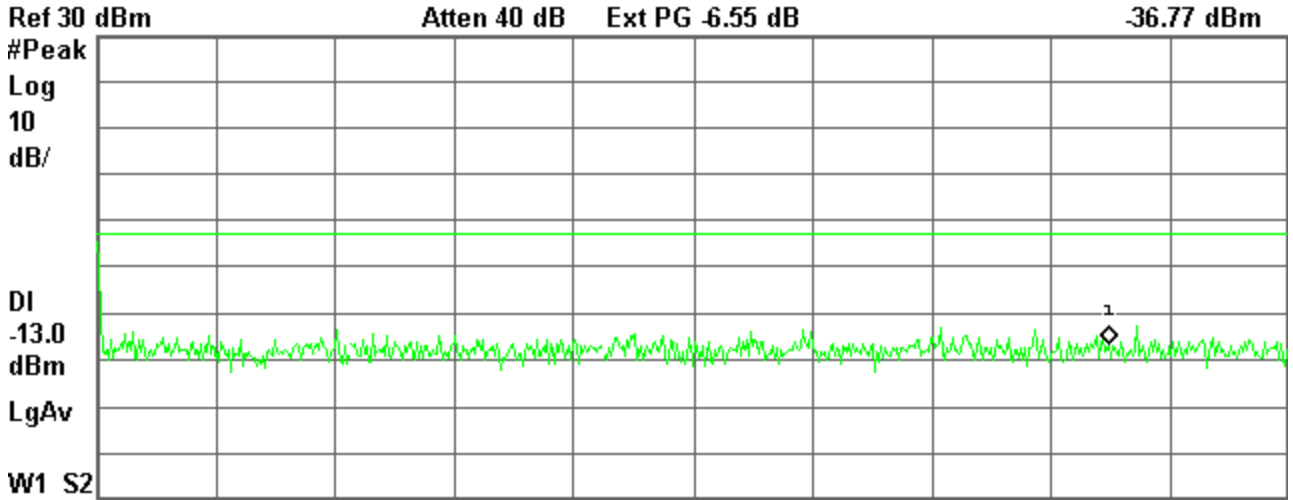

Start 1.0 MHz Stop 1.000 0 GHz
 Res BW 3 MHz VBW 3 MHz Sweep 1.68 ms (601 pts)

Marker	Trace	Type	X Axis	Amplitude
1	(1)	Freq	848.5 MHz	-36.77 dBm

SIERRA WIRELESS, INC.

Plot 3.4b Out of Band Emissions at Antenna Terminals

Low channel, 1851.25 MHz

TX signal +/- 20 MHz

Agilent 17:45:41 Sep 18, 2002

L

Mkr3 1.870 38 GHz
-39.468 dBm

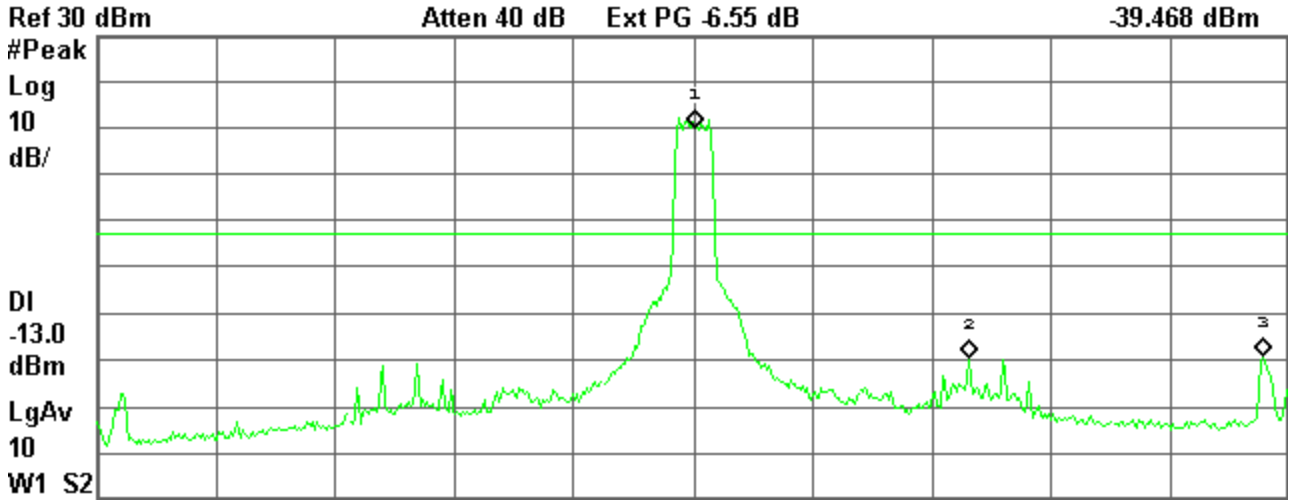

Marker	Trace	Type	X Axis	Amplitude
1	(1)	Freq	1.851 32 GHz	10.30 dBm
2	(1)	Freq	1.860 52 GHz	-39.72 dBm
3	(1)	Freq	1.870 38 GHz	-39.47 dBm

SIERRA WIRELESS, INC.

Plot 3.4c Out of Band Emissions at Antenna Terminals

Low channel, 1851.25 MHz

1 GHz to 20 GHz

Agilent 17:48:46 Sep 18, 2002

L

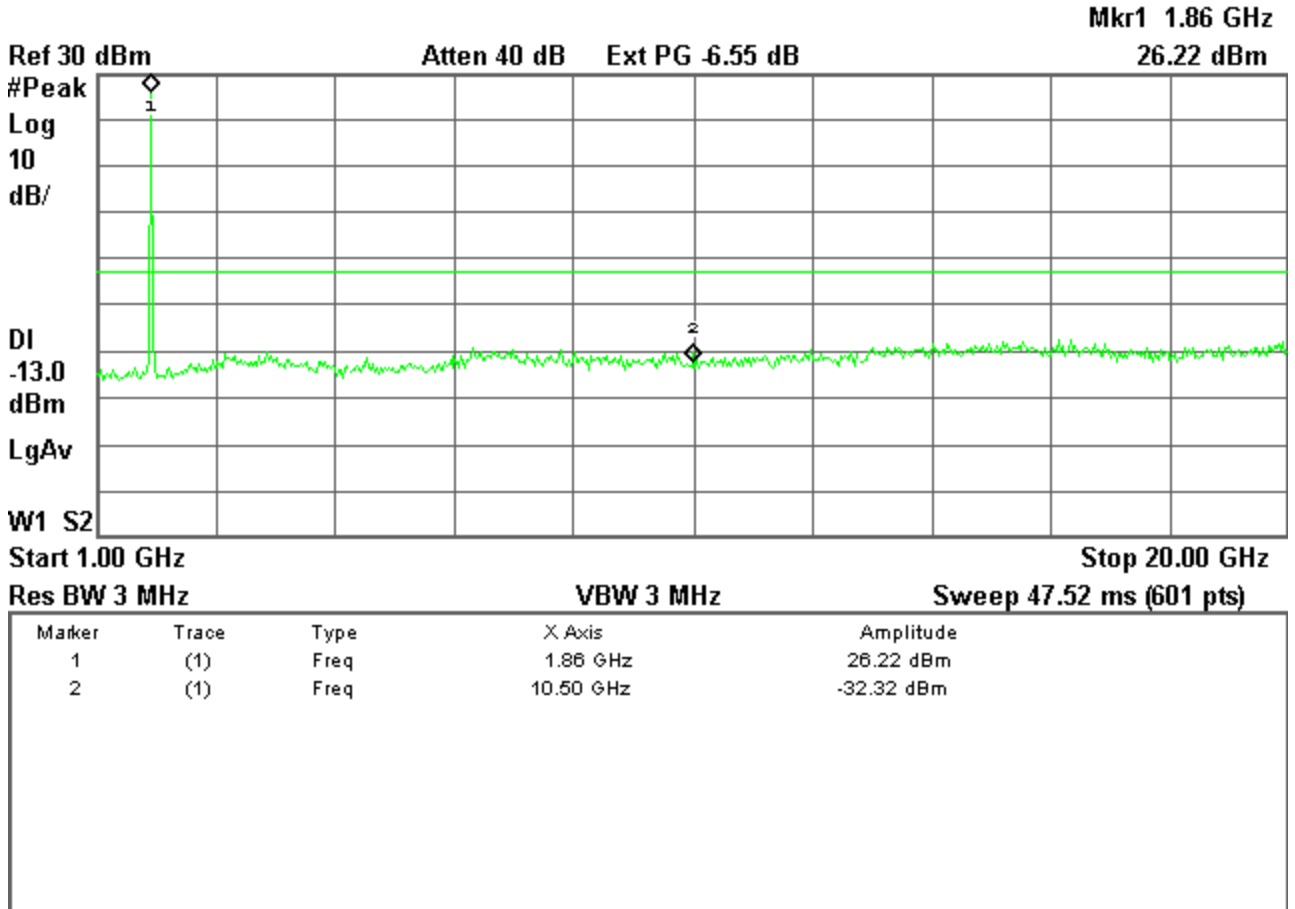

SIERRA WIRELESS, INC.

Plot 3.5b Out of Band Emissions at Antenna Terminals

Mid Channel, 1880 MHz

TX signal +/- 20 MHz

Agilent 17:46:24 Sep 18, 2002

L

Mkr3 1.899 13 GHz
-41.101 dBm

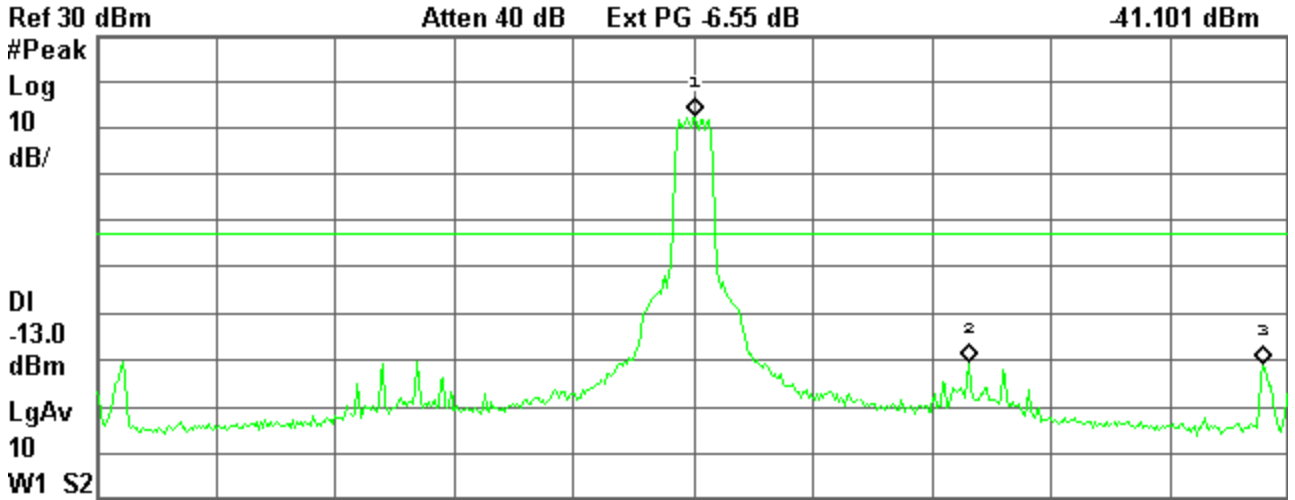

Marker	Trace	Type	X Axis	Amplitude
1	(1)	Freq	1.880 07 GHz	12.79 dBm
2	(1)	Freq	1.889 27 GHz	-40.42 dBm
3	(1)	Freq	1.899 13 GHz	-41.10 dBm

SIERRA WIRELESS, INC.

Plot 3.5c Out of Band Emissions at Antenna Terminals

Mid Channel, 1880 MHz

1 GHz to 20 GHz

Agilent 17:48:21 Sep 18, 2002

L

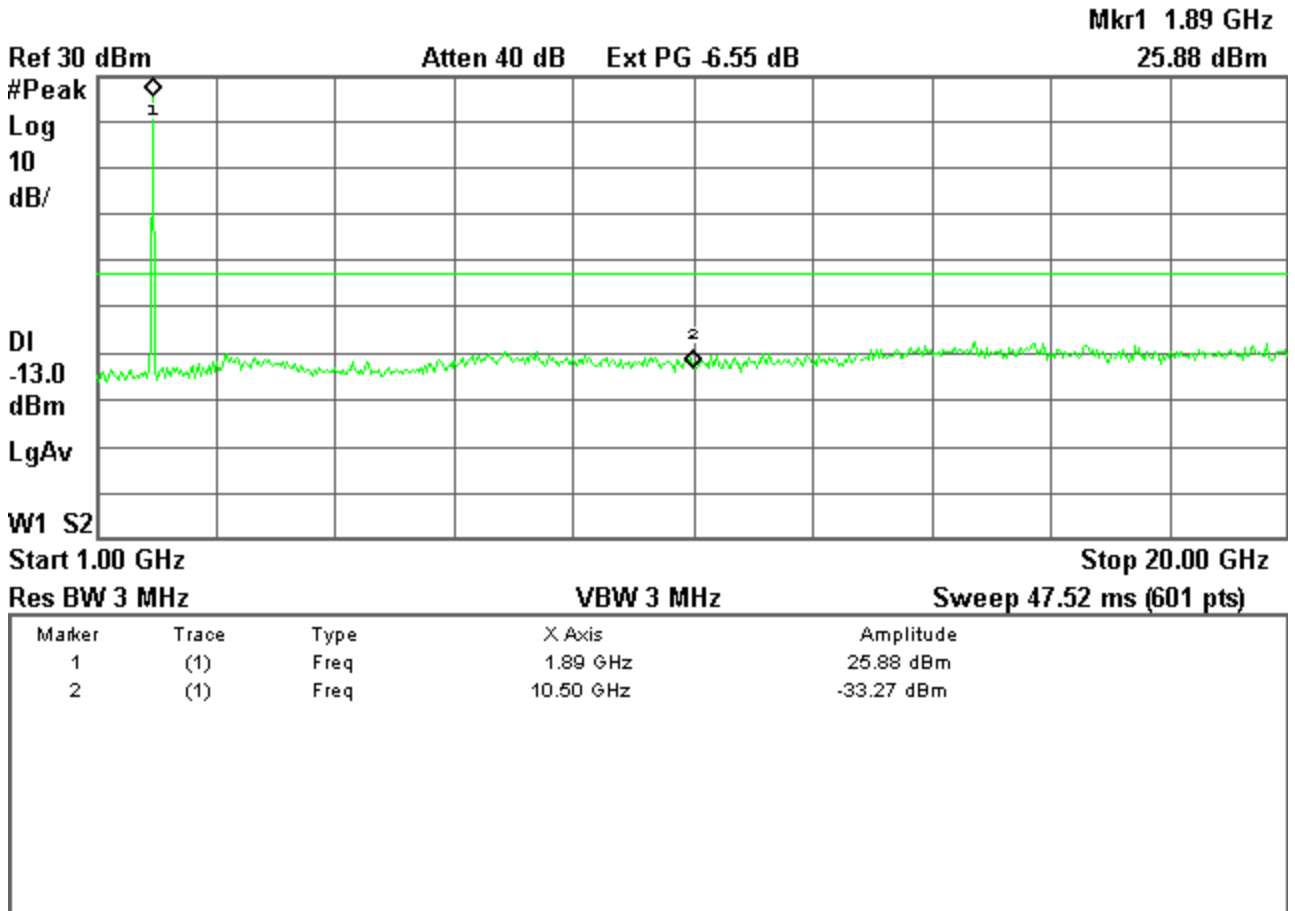

SIERRA WIRELESS, INC.

Plot 3.6a Out of Band Emissions at Antenna Terminals

High Channel, 1908.75 MHz

1 Mhz to 1 GHz

Agilent 17:37:06 Sep 18, 2002

L

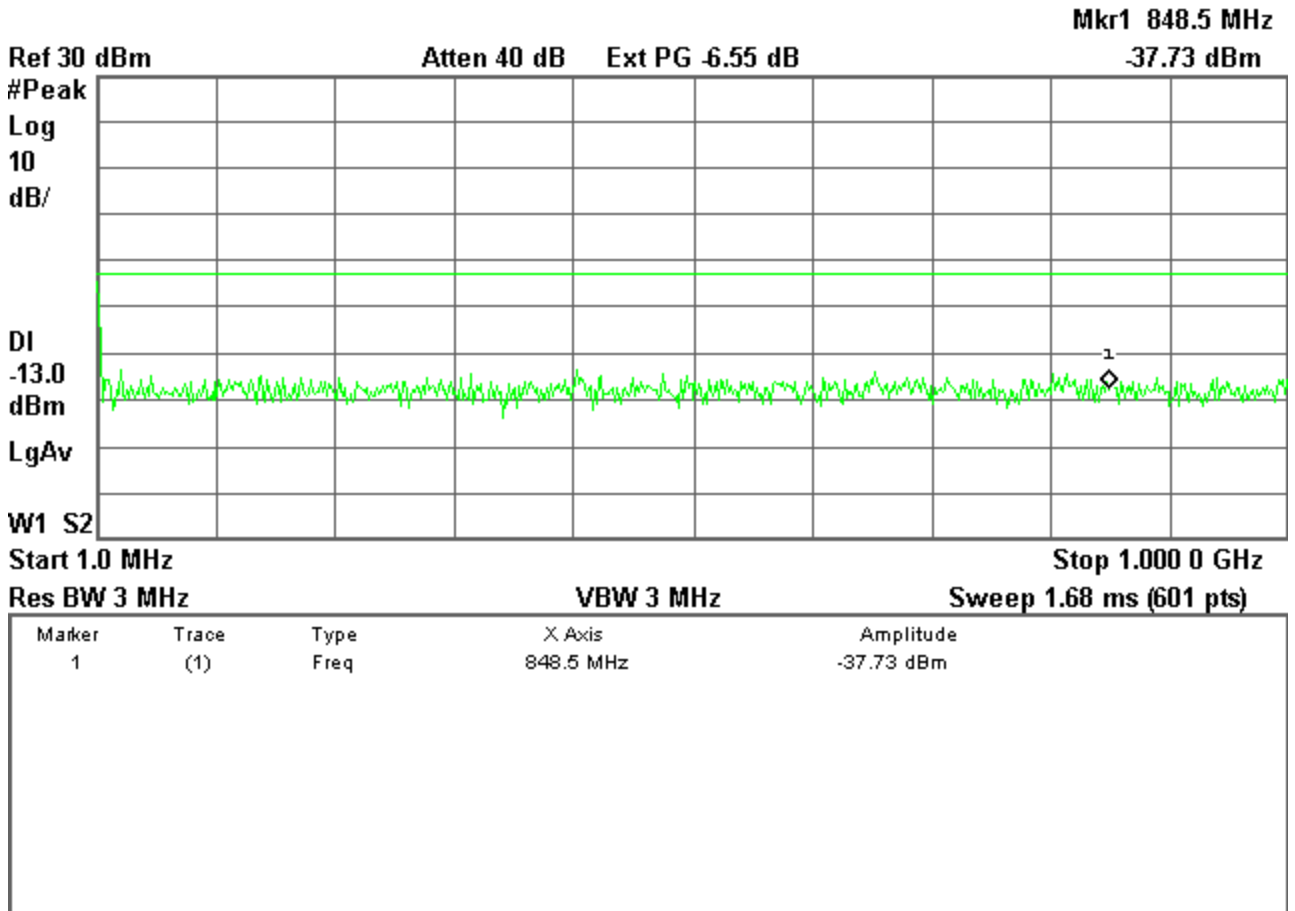

SIERRA WIRELESS, INC.

Plot 3.6b Out of Band Emissions at Antenna Terminals

High Channel, 1908.75 MHz

TX signal +/- 20 MHz

✱ Agilent 17:47:09 Sep 18, 2002

L

Mkr3 1.889 62 GHz

-38.350 dBm

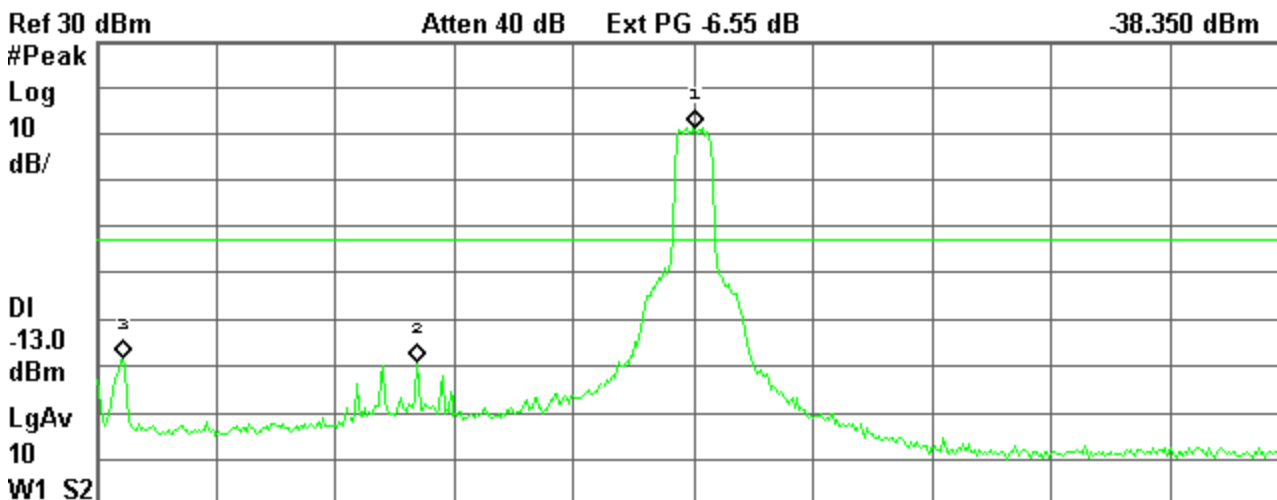

Marker	Trace	Type	X Axis	Amplitude
1	(1)	Freq	1.908 82 GHz	11.49 dBm
2	(1)	Freq	1.899 48 GHz	-39.21 dBm
3	(1)	Freq	1.889 62 GHz	-38.35 dBm

SIERRA WIRELESS, INC.

Plot 3.6c Out of Band Emissions at Antenna Terminals

High Channel, 1908.75 MHz

1 GHz to 20 GHz

Agilent 17:47:59 Sep 18, 2002

L

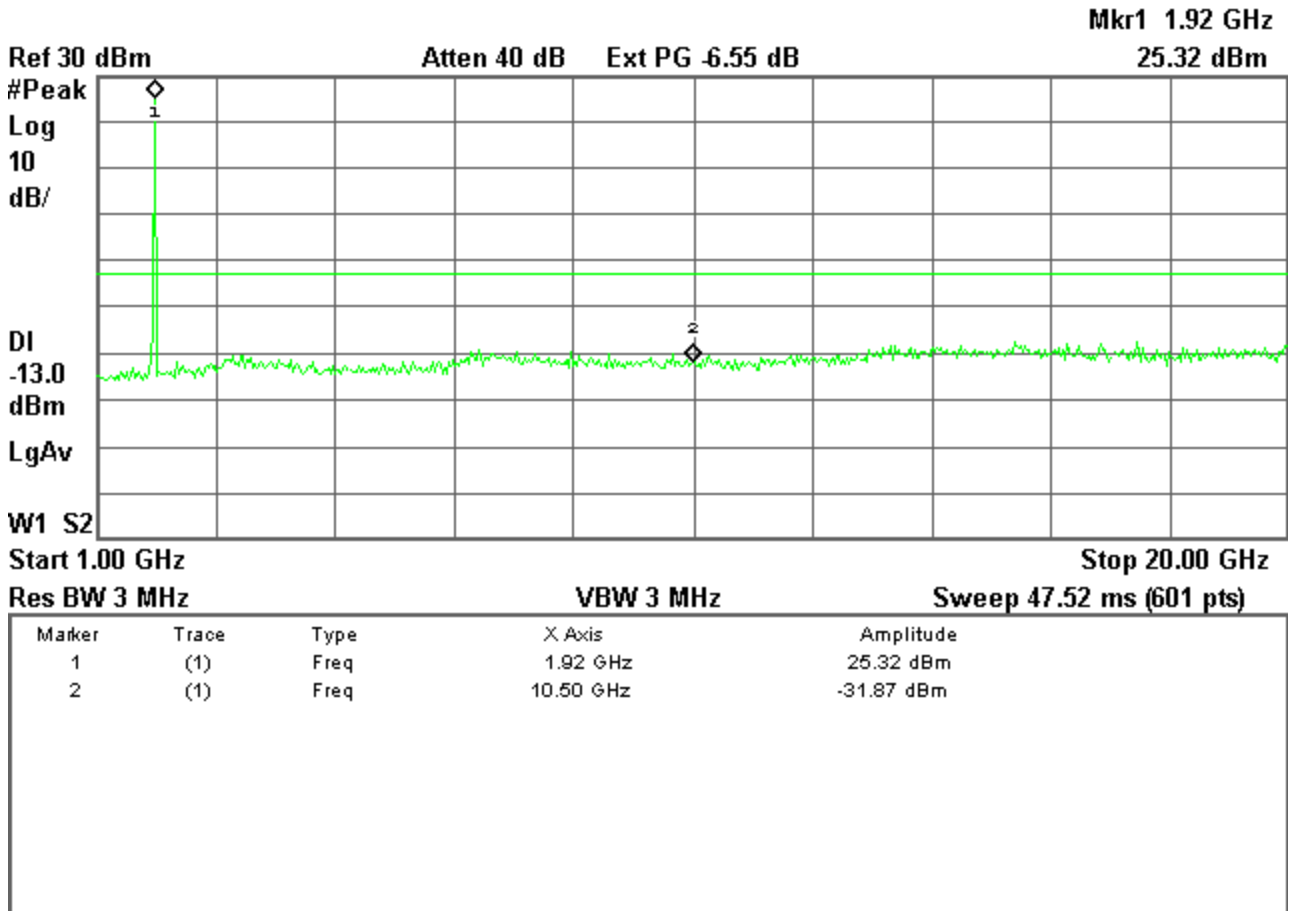

SIERRA WIRELESS, INC.

Plot 3.7a Low Channel, 824.70 MHz

* Agilent 17:56:43 Sep 18, 2002

L

Mkr1 880.88 MHz
-93.85 dBm

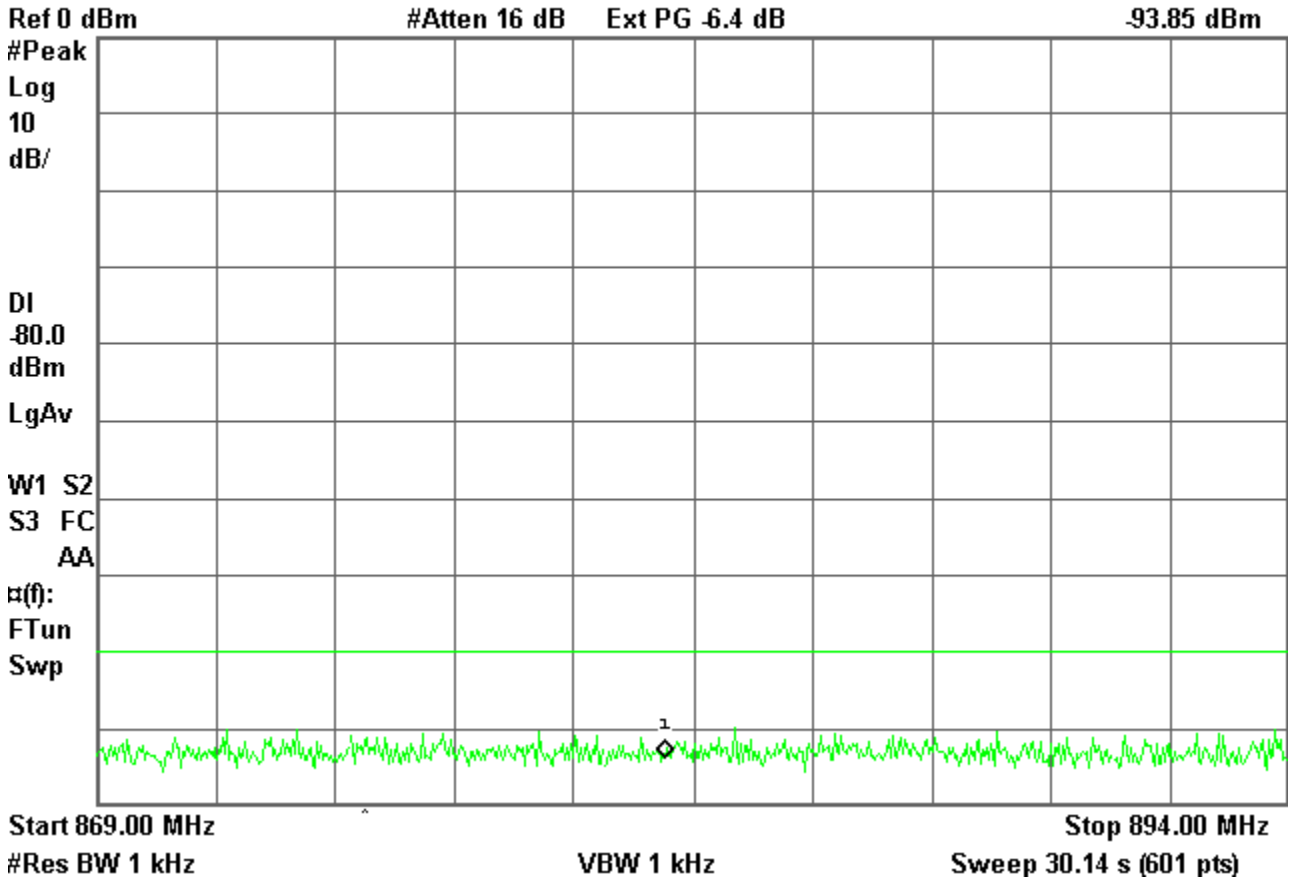

SIERRA WIRELESS, INC.

Plot 3.7a Middle Channel, 836.52 MHz

* Agilent 17:57:31 Sep 18, 2002

L

Mkr1 880.88 MHz
-93.31 dBm

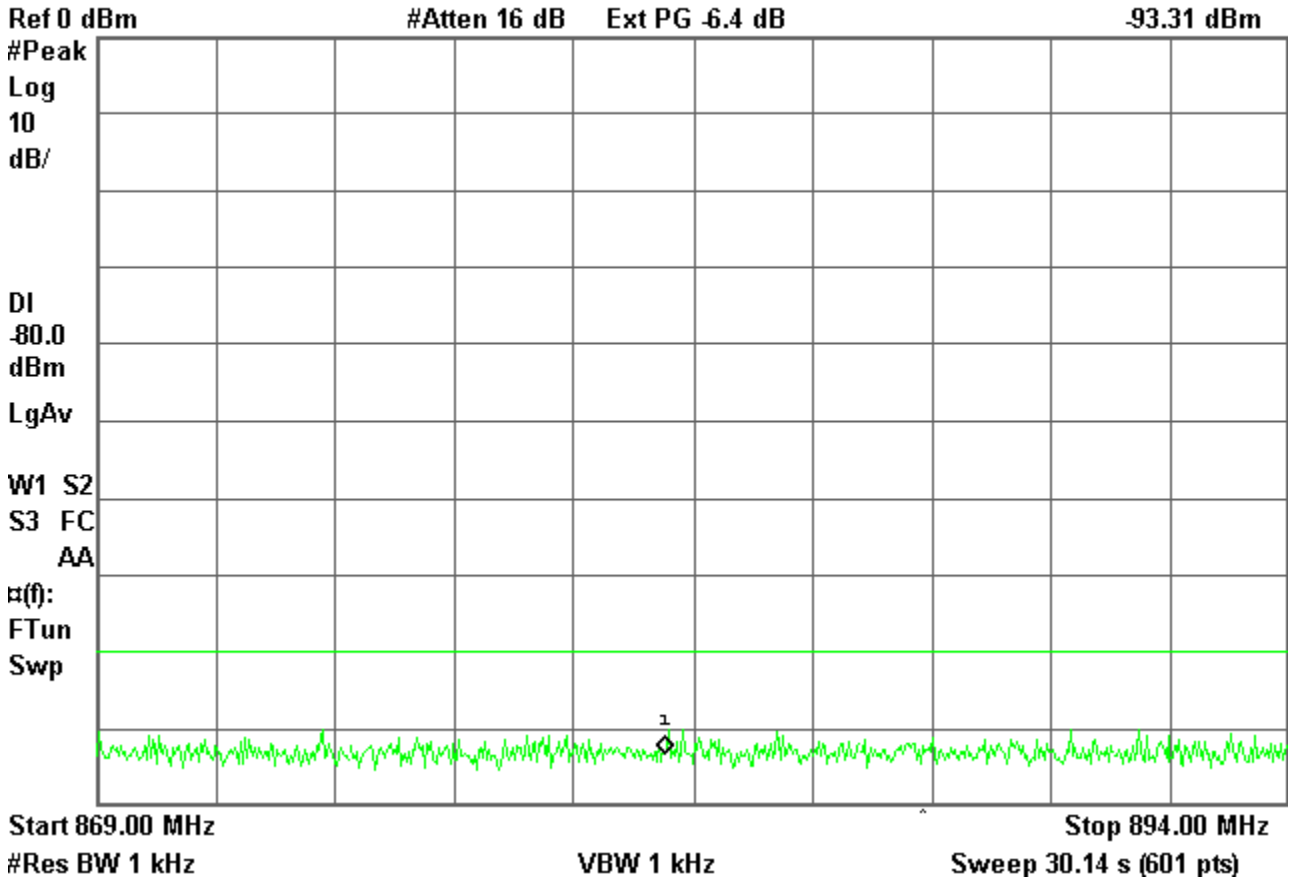

SIERRA WIRELESS, INC.

Plot 3.7c High Channel, 848.31 MHz

* Agilent 17:58:40 Sep 18, 2002

L

Mkr1 880.88 MHz
-92.75 dBm

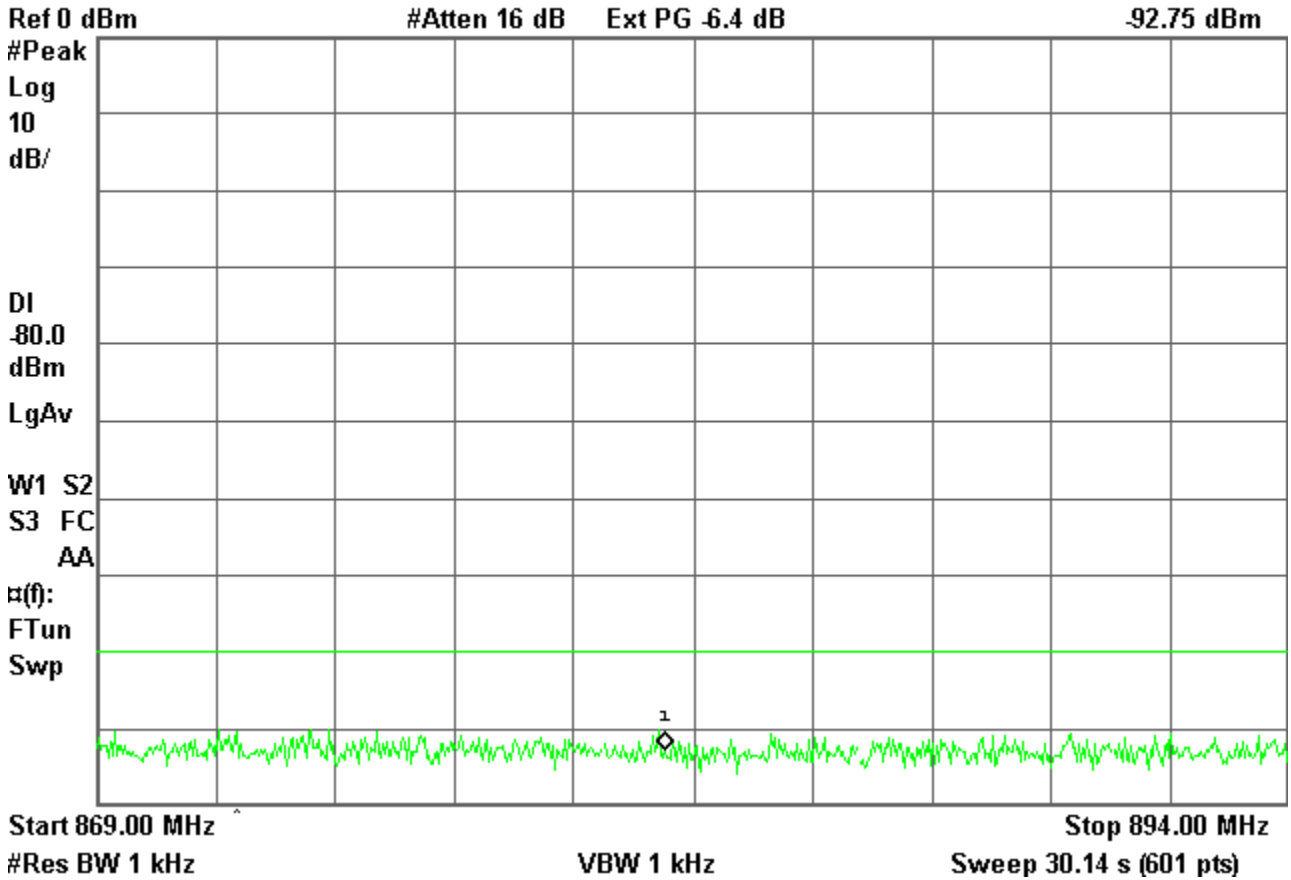

8 Frequency Stability vs Temperature

FCC 2.1055

8.1 Test Procedure

The SB555-S was placed inside the temperature chamber. The transmitting frequency error is measured at 25 deg C, then the temperature is set to -30 deg C and allowed to stabilize. After sufficient soak time, the transmitting frequency error is measured. The temperature is increased by 10 degrees, allowed to stabilize and soak, then the measurement is repeated. This is repeated until 80 deg C is completed. Frequency metering included averaging of 50 samples per reading to stabilize the reading. Reference power supply voltage for these tests is 3.30 volts.

Test Setup

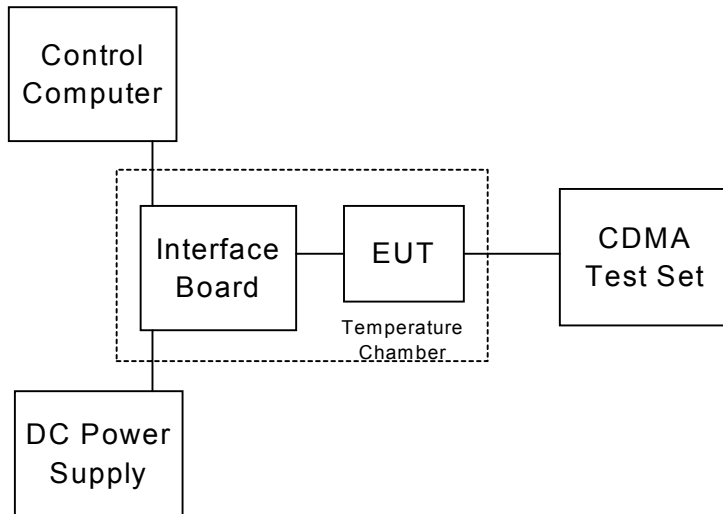

8.2 Test Equipment

EQUIPMENT	MANUFACTURER	MODEL	SERIAL NO.	Last CAL. DATE
Wireless Test Set	Agilent	8960	US41070182	09/05/2001
DC Power Supply	Hewlett Packard	E3631A	MY40003202	1/11/00
Temperature Chamber	Sigma Systems	M30M	7550	N/a
Control Computer	ACT	Canadien	N/A	N/a
Interface Board	Shop built	Nest	N/a	N/a

SIERRA WIRELESS, INC.

FCC Part 22 & 24 Test Report	SB555-S	Sept 2002	Page 41 of 43
------------------------------	---------	-----------	---------------

8.3 Test Results

PCS band

	1880.00 MHz	
Temperature (degC)	Frequency error (Hz)	Worst case Frequency error (ppm)
25	1.83	.001
-30	1.21	-.001
-20	2.21	0
-10	2.22	.001
0	1.29	-.002
10	-0.32	-.002
20	-0.55	-.001
30	2.22	0
40	1.17	.001
50	1.65	.001
60	2.74	.001
70	1.18	.001
80	-1.89	.002

9 Frequency Stability vs Voltage

FCC 2.1055

9.1 Test Procedure

The SB555-S was connected to a DC Power Supply and a CDMA test set with frequency error measurement capability. The power supply output is adjusted to the test voltage as measured at the input terminals to the module while transmitting. A voltmeter was used to confirm the terminal voltage.

The test voltages are:

3.15 V, rated voltage

3.2 V, minimum specified operating voltage

4.2 V, maximum specified operating voltage.

The output frequency error was recorded for each voltage setting at one center channel for each band of operation. Frequency metering included averaging of 50 samples per reading to stabilize the reading.

Test Setup

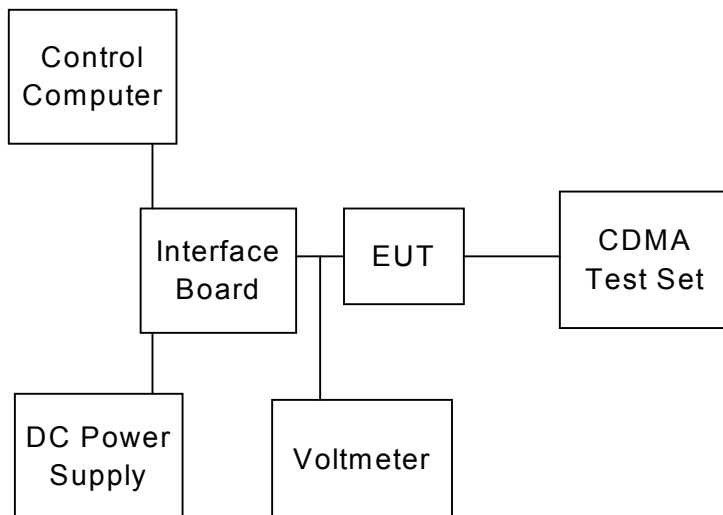

SIERRA WIRELESS, INC.

FCC Part 22 & 24 Test Report	SB555-S	Sept 2002	Page 43 of 43
------------------------------	---------	-----------	---------------

9.2 Test Equipment

EQUIPMENT	MANUFACTURER	MODEL	SERIAL NO.	Last Cal. DATE
CDMA Test Set	Agilent	8960	US41070182	09/05/2001
DC Power Supply	Hewlett Packard	HP6632A	3326A-03423	N/A
Control Computer	TC	Generic PC	100844	N/a
Interface Board	Shop built	Nest	N/a	N/a
Voltmeter	Fluke	75III	78270326	21/12/01

9.3 Test Results

Cellular Band

Expected Transmitting Frequency : **837.00 MHz**

Vcc (Volts)	Measured Frequency Error (Hz)	Measured Frequency Error (ppm) see note 1 below
3.3	2.77	.001 (+/- .006)
3.2	3.29	-.002 (+/- .006)
4.2	0.77	-.001 (+/- .006)

PCS Band

Expected Transmitting Frequency: **1880 MHz**

Vcc (Volts)	Measured Frequency Error (Hz)	Measured Frequency Error (ppm) see note 1 below
3.3	2.00	0 (+/- .006)
3.2	1.02	.001 (+/- .006)
4.2	1.14	.001 (+/- .006)

Note 1 There is considerable short-term variation of the frequency as measured on an 8960 test set. Without averaging, an actual error of 0 Hz can appear to vary from -50 to +50 Hz from one sample to the next due to the effect of the CDMA modulation. Averaging helps steady this variation down to +/- 5 Hz or less, and that is what was used for our tests. Observation of the readings by the test engineer are that the variation is symmetrical around 0 Hz.

This data shows that frequency stability versus voltage meets the requirements.