

# RF Exposure Evaluation in co-locating with other transmitters

The applying modular device (FCC ID: N7NMC8755) has a capability to transmit RF frequency simultaneously with the following transmitters in the Lenovo laptop PCs, **ThinkPad R60 Series**.

Tx type	FCC ID	Grantee Name	The latest Granted Date	Conducted Max. Tx power
Bluetooth adapter	MCLJ07H081	HON HAI Precision Ind. Co., Ltd.	June/ 23 / 2005	0.003 (Part 15C)
WLAN adapter	PPD-AR5BXB6	Atheros Communications, Inc.	July / 14/ 2005	0.190 (Part 15C) 0.041 (Part 15E)

**Figure-1 Antenna assembly of R60 series**

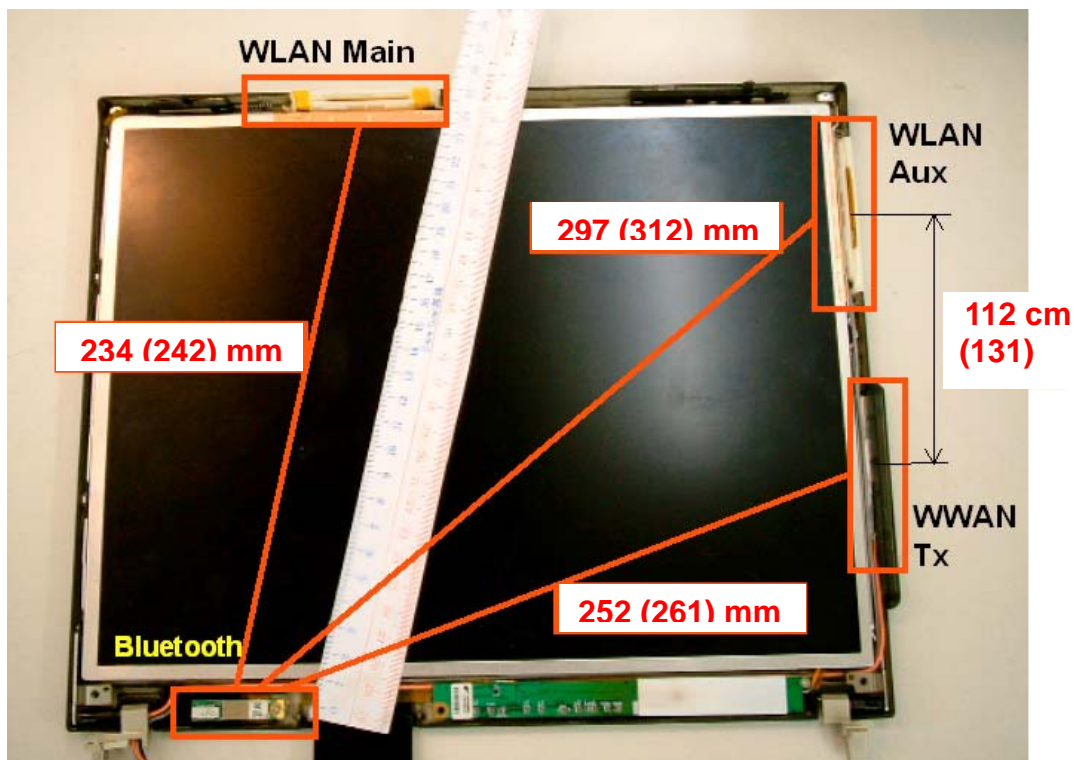
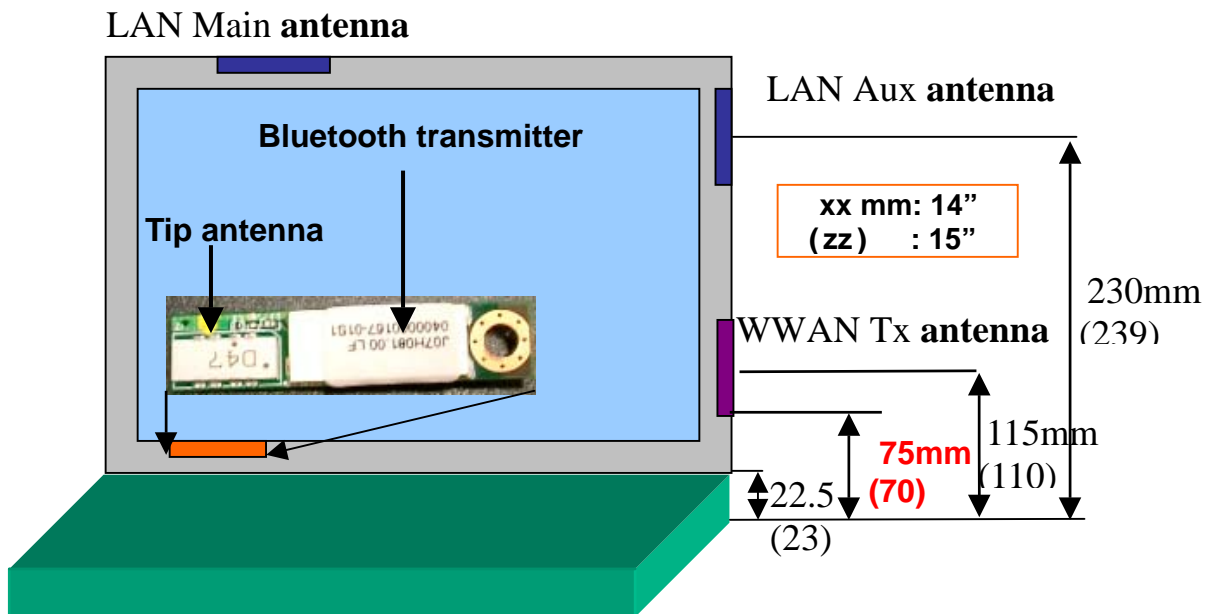

#### **a. RF Exposure evaluation with the WWAN and WLAN modules**

The separation distance between human body and the WWAN Tx antennas in the new host PC devices (ThinkPad R60 Series) is 70mm. Therefore the applying WWAN transmitter module and the antenna systems are categorized as a Portable device pursuant to FCC CFR 47 Section 2.1093.

Also the separation distance between the WWAN and WLAN Main antennas is within 20cm. Therefore those transmitters are regarded as co-located devices, then the SAR testing in co-locating condition is required for the RF Exposure evaluation.

The separate SAR report includes the measurement results performed with the applying transmitter (FCC ID: N7NMC8755) and the co-located WLAN transmitter in active and transmitting simultaneously.

The EUT was found to comply with the limit of SAR requirement according to FCC CFR 47 section 2.1093, Portable devices.

#### **b. RF Exposure evaluation with the WWAN and Bluetooth modules**

As shown in the previous Figure-1, the Bluetooth antenna in ThinkPad R60 Series is assembled apart from the WWAN and WLAN antennas with 20 cm or more.

Therefore, the Bluetooth transmitter is not considered as a co-located device, and is allowed to evaluate the RF exposure compliance independently of the applying WWAN modular transmitter or other co-located WLAN ones. In other word, the SAR testing for the applying WWAN device in simultaneous transmitting with the Bluetooth device is not required, when the Bluetooth device satisfies the RF exposure requirement with its own transmission power.

When a customer operates the Lenovo laptop PC on one's lap, the sufficient separation distance (minimum 20cm) between the above Bluetooth antenna and the person's body (lap) can not be maintained. However the footnote<sup>14</sup> of the Section 3 in Supplement C to OET Bulletin 65 states:

<sup>14</sup> If a device, its antenna or other radiating structures are operating at closer than 2.5 cm from a person's body or in contact with the body, SAR evaluation may be necessary when the output is more than 50 – 100 mW, depending on the device operating configurations and exposure conditions.”

The output power of the Bluetooth device is 3mW (far below 50mW). Therefore the BT transmitter satisfies the RF exposure requirement regarding CFR 47 Part 15.247(b)(4) without a SAR compliance test report, and can operate with the applying WWAN transmitter simultaneously.

Thus, the applying WWAN transmitter(FCC ID: N7NMC8755), the co-located WLAN transmitter (FCC ID: PPD-AR5BXB6) and Bluetooth module(FCC ID: MCLJ07H081) satisfy the RF exposure requirement, and can operate simultaneously in the subjected Lenovo laptop PCs.