



**FCC CFR47 PART 22H & 24E
INDUSTRY CANADA RSS-132 ISSUE 2 & RSS-133 ISSUE 5
CLASS II PERMISSIVE CHANGE
CERTIFICATION TEST REPORT
FOR**

**CELLULAR/PCS GSM/GPRS/EDGE/CDMA/ED0/WCDMA/HSPA AND
700MHZ LTE WIRELESS MODULE**

MODEL NUMBER: MC7750

FCC ID: N7NMC7750, N7NMC7750-L

IC: 2417C-MC7750

REPORT NUMBER: 11U14140-1

ISSUE DATE: MARCH 20, 2012

Prepared for
**SIERRA WIRELESS INC.
2290 COSMOS CT
CARLSBAD, CA 92010, U.S.A.**

Prepared by
**COMPLIANCE CERTIFICATION SERVICES (UL CCS)
47173 BENICIA STREET
FREMONT, CA 94538, U.S.A.
TEL: (510) 771-1000
FAX: (510) 661-0888**



NVLAP LAB CODE 200065-0

Revision History

Rev.	Issue Date	Revisions	Revised By
---	03/20/12	Initial Issue	T. Chan

1. ATTESTATION OF TEST RESULTS

COMPANY NAME: SIERRA WIRELESS INC.
2290 COSMOS CT
CARLSBAD, CA 92010, U.S.A

EUT DESCRIPTION: CELLULAR/PCS GSM/GPRS/EDGE/CDMA/EDO/WCDMA/HSPA
AND 700MHZ LTE WIRELESS MODULE

MODEL: MC7750

SERIAL NUMBER: 431

DATE TESTED: MARCH 7 TO 9, 2012

APPLICABLE STANDARDS	
STANDARD	TEST RESULTS
FCC PART 22H & 24E	Pass
IC RSS-132 ISSUE 2 & RSS- 133 ISSUE 5	Pass

Compliance Certification Services (UL CCS) tested the above equipment in accordance with the requirements set forth in the above standards. All indications of Pass/Fail in this report are opinions expressed by UL CCS based on interpretations and/or observations of test results. Measurement Uncertainties were not taken into account and are published for informational purposes only. The test results show that the equipment tested is capable of demonstrating compliance with the requirements as documented in this report.

Note: The results documented in this report apply only to the tested sample, under the conditions and modes of operation as described herein. This document may not be altered or revised in any way unless done so by UL CCS and all revisions are duly noted in the revisions section. Any alteration of this document not carried out by UL CCS will constitute fraud and shall nullify the document. This report must not be used by the client to claim product certification, approval, or endorsement by NVLAP, NIST, any agency of the Federal Government, or any agency of any government.

Approved & Released For UL CCS By:

Tested By:

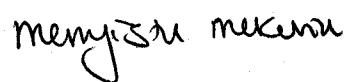

THU CHAN
ENGINEERING MANAGER
UL CCS

MENGISTU MEKURIA
EMC ENGINEER
UL CCS

2. TEST METHODOLOGY

The tests documented in this report were performed in accordance with TIA-603-C, FCC CFR 47 Part 2, FCC CFR 47 Part 22, FCC CFR Part 24, RSS-132 Issue 2 and RSS-133 Issue 5.

3. FACILITIES AND ACCREDITATION

The test sites and measurement facilities used to collect data are located at 47173 Benicia Street, Fremont, California, USA.

UL CCS is accredited by NVLAP, Laboratory Code 200065-0. The full scope of accreditation can be viewed at <http://www.ccsemc.com>.

4. CALIBRATION AND UNCERTAINTY

4.1. MEASURING INSTRUMENT CALIBRATION

The measuring equipment utilized to perform the tests documented in this report has been calibrated in accordance with the manufacturer's recommendations, and is traceable to recognized national standards

4.2. SAMPLE CALCULATION

Where relevant, the following sample calculation is provided:

$$\text{Field Strength (dBuV/m)} = \text{Measured Voltage (dBuV)} + \text{Antenna Factor (dB/m)} + \text{Cable Loss (dB)} - \text{Preamp Gain (dB)}$$

$$36.5 \text{ dBuV} + 18.7 \text{ dB/m} + 0.6 \text{ dB} - 26.9 \text{ dB} = 28.9 \text{ dBuV/m}$$

4.3. MEASUREMENT UNCERTAINTY

Where relevant, the following measurement uncertainty levels have been estimated for tests performed on the apparatus:

PARAMETER	UNCERTAINTY
Conducted Disturbance, 0.15 to 30 MHz	3.52 dB
Radiated Disturbance, 30 to 1000 MHz	4.94 dB

Uncertainty figures are valid to a confidence level of 95%.

5. EQUIPMENT UNDER TEST

5.1. DESCRIPTION OF EUT

The EUT is a Cellular/PCS GSM/GPRS/EDGE/CDMA/ED0/WCDMA/HSPA AND 700MHZ LTE WIRELESS MODULE that is manufactured by Sierra Wireless Inc.

5.2. MAXIMUM OUTPUT POWER

The transmitter has a maximum average conducted output powers as follows:

Part 22 Cellular Band			
Frequency range (MHz)	Modulation	Conducted	
		dBm	mW
824.20 – 848.80	GPRS	31.64	1458.8
824.20 – 848.80	EGPRS	25.90	389.0
824.70 – 848.31	CDMA 1xRTT	25.26	335.7
824.70 – 848.31	CDMA EVDO REV 0	25.37	344.3
824.70 – 848.31	CDMA EVDO REV A	25.26	335.7
826.20 – 846.80	UMTS, Rel 99	23.08	203.2
826.20 – 846.80	UMTS, HSDPA	22.80	190.5
826.20 – 846.80	UMTS, HSDPA	22.22	166.7

Part 24 PCS Band			
Frequency range (MHz)	Modulation	Conducted	
		dBm	mW
1850.2-1909.8	GPRS	28.32	679.2
1850.2-1909.8	EGPRS	24.89	308.3
1851.25-1908.75	CDMA 1xRTT	25.41	347.5
1851.25-1908.75	CDMA EVDO REV 0	25.44	349.9
1851.25-1908.75	CDMA EVDO REV A	25.22	332.7
1852.40-1907.60	UMTS, Rel 99	22.61	182.4
1852.40-1907.60	UMTS, HSDPA	22.11	162.6
1852.40-1907.60	UMTS, HSDPA	21.79	151.0

5.3. Class II PERMISSIVE CHANGE DESCRIPTION

The major change filed under this application is the PCB change for the diversity receiver circuitry.

5.4. SOFTWARE AND FIRMWARE

The EUT made a radio link with Agilent 8960 communication test set during the test.

5.5. WORST-CASE CONFIGURATION AND MODE

The worst-case channel for RF radiated emissions below 1GHz and AC conducted emissions are determined as the channel with the AC Power Adapter Source

Based on the investigation results from the original report, the highest peak power and enhanced data rate is the worst-case scenario for all measurements.

Worst-case modes:

- GPRS (GMSK)
- CDMA 2000

For the fundamental investigation, since the EUT has multi-directional diversity antennas; therefore X and Z orientations have been investigated. And after the investigations the worst case was found to be a Z-position and X-positions Cell and PCS bands respectively.

5.6. DESCRIPTION OF TEST SETUP

RADIATED TESTS SUPPORT EQUIPMENT

PERIPHERAL SUPPORT EQUIPMENT LIST			
Description	Manufacturer	Model	Serial Number
Test Jig	SIERRA WIRELESS	1201477-2.0	MCDK2410
AC Adapter	ELPAC POWER SYSTEMS	FW1805	32619

I/O CABLES (RF Conducted Test)

I/O CABLE LIST						
Cable No.	Port	# of Identic Ports	Connector Type	Cable Type	Cable Length	Remarks
1	AC	1	AC	UN-SHELDED	2.0m	N/A
2	DC	1	DC	UN-SHELDED	2.0m	N/A
3	RF	1	SMA	SHELDED	0.6 m	N/A

I/O CABLES (RF Radiated Test)

I/O CABLE LIST						
Cable No.	Port	# of Identic Ports	Connector Type	Cable Type	Cable Length	Remarks
1	AC	1	AC	UN-SHELDED	2.0m	N/A
2	DC	1	DC	UN-SHELDED	2.0m	N/A

TEST SETUP

CONDUCTED SETUP DIAGRAM FOR TESTS

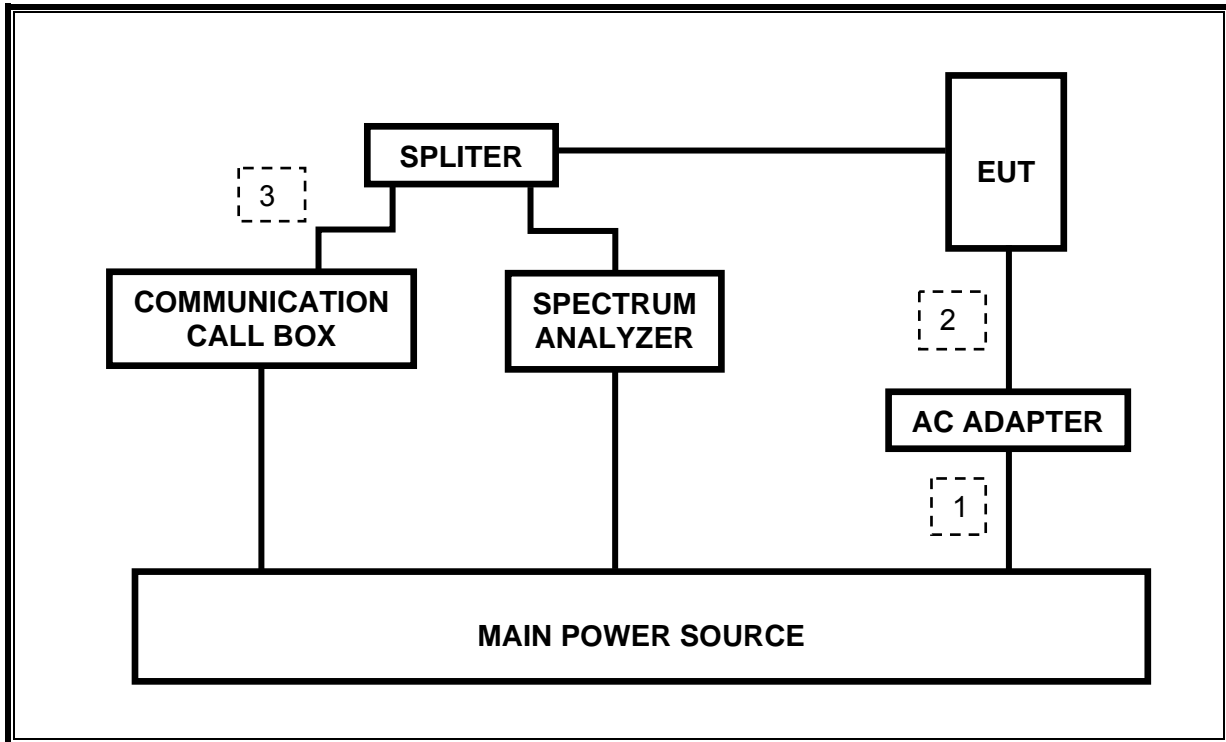

RADIATED SETUP DIAGRAM FOR TESTS

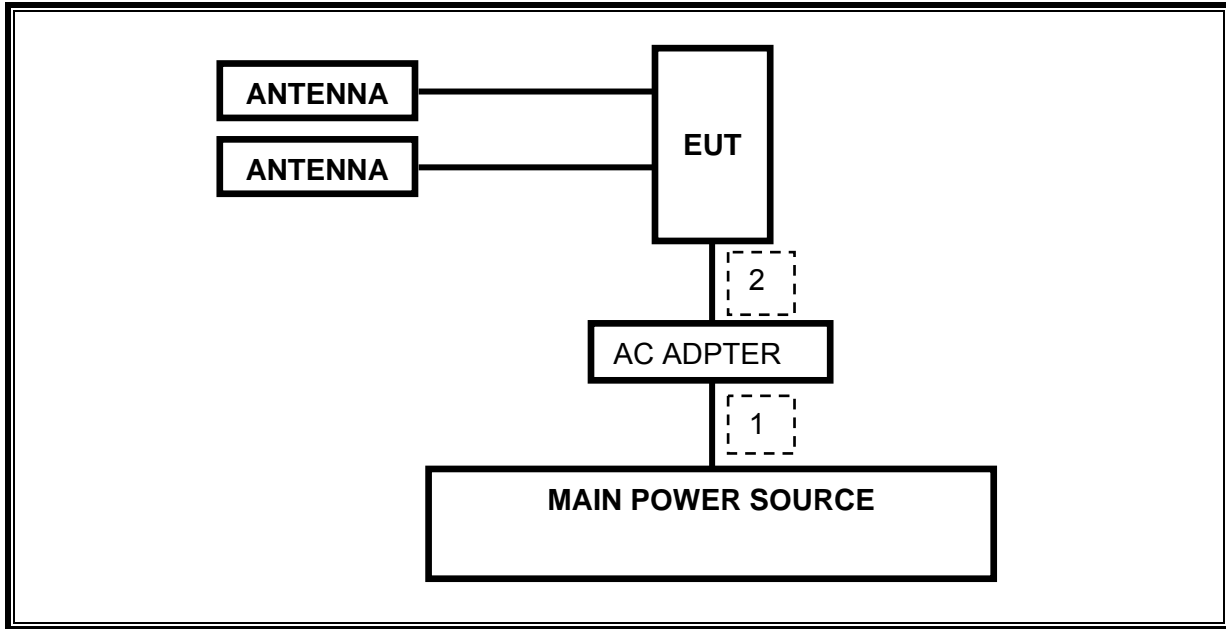

6. TEST AND MEASUREMENT EQUIPMENT

The following test and measurement equipment was utilized for the tests documented in this report:

TEST EQUIPMENT LIST				
Description	Manufacturer	Model	Asset	Cal Due
Spectrum Analyzer, 26.5 GHz	Agilent / HP	E4440A	C01179	02/16/13
Spectrum Analyzer, 44 GHz	Agilent / HP	E4446A	C01012	09/02/12
Antenna, Horn, 18 GHz	EMCO	3115	C00783	06/29/12
Antenna, Horn, 18 GHz	EMCO	3115	C00945	06/29/12
Antenna, Bilog, 2 GHz	Sunol Sciences	JB1	C01011	06/30/12
Preamplifier, 1300 MHz	Agilent / HP	8447D	C00558	11/11/12
Preamplifier, 26.5 GHz	Agilent / HP	8449B	C01052	07/12/12
Preamplifier, 26.5 GHz	Agilent / HP	8449B	C01063	07/12/12
Communications Test Set	Agilent / HP	E5515C	C01086	06/17/12
Communication Test Set	R & S	CMU 200	C01131	06/24/12
Temperature / Humidity Chamber	Thermotron	SE 600-10-10	C00930	04/20/12
Highpass Filter, 1.5 GHz	Micro-Tronics	HPM13193	N02689	CNR
Highpass Filter, 2.7 GHz	Micro-Tronics	HPM13194	N02687	CNR
Directional Coupler, 4.2 GHz, 40 dB	A-R	DC7144A	C00983	CNR
Sleeve Dipole 1730~2030 MHz	ETS	3126-1880	C01157	10/27/12
Signal Generator, 20 GHz	Agilent / HP	83732B	C00774	07/14/12
Antenna, Tuned Dipole 400~1000 MHz	ETS	3121C DB4	C00993	07/10/12

7. CONDUCTED TEST RESULTS

7.1. BAND EDGE

RULE PART(S)

FCC: §22.359 and 24.238

IC: RSS-132, 4.5 and RSS-133, 6.5

LIMITS

The power of any emission outside of the authorized operating frequency ranges must be attenuated below the transmitting power (P) by a factor of at least $43 + 10 \log (P)$ dB.

TEST PROCEDURE

The transmitter output was connected to an Agilent 8960 Test Set and configured to operate at maximum power. The band edge emissions were measured at the required operating frequencies in each band on the Spectrum Analyzer.

For each band edge measurement:

- Set the spectrum analyzer span to include the block edge frequency (824, 849, 1850, 1910MHz)
- Set a marker to point the corresponding band edge frequency in each test case.
- Set display line at -13 dBm
- Set resolution bandwidth to at least 1% of emission bandwidth.

MODES TESTED

- GPRS and EGPRS
- CDMA 1xRTT and EVDO rev 0 & A

RESULTS

BANDEDGE

GPRS850 BAND

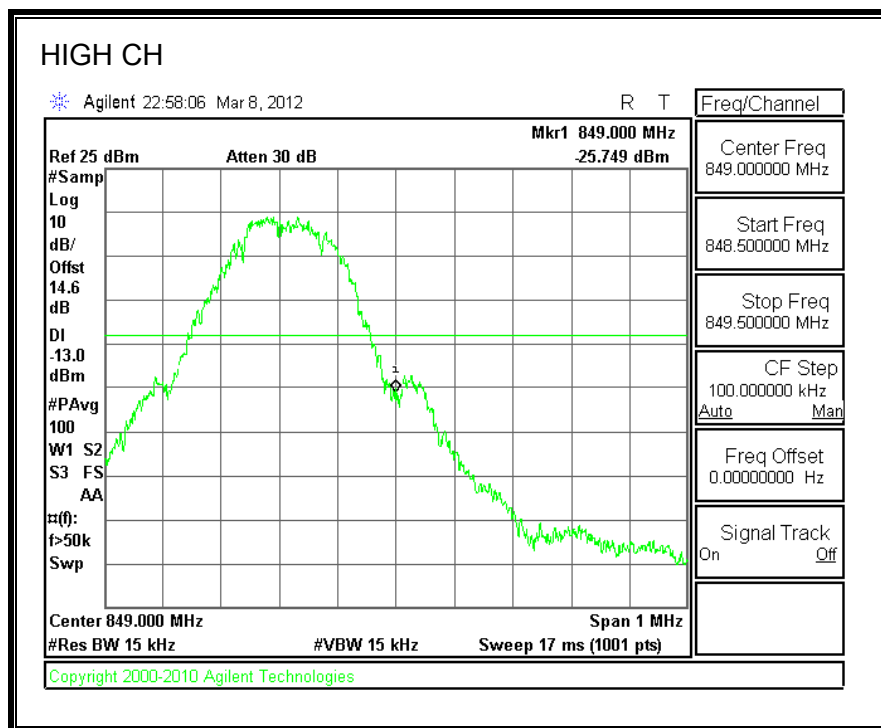
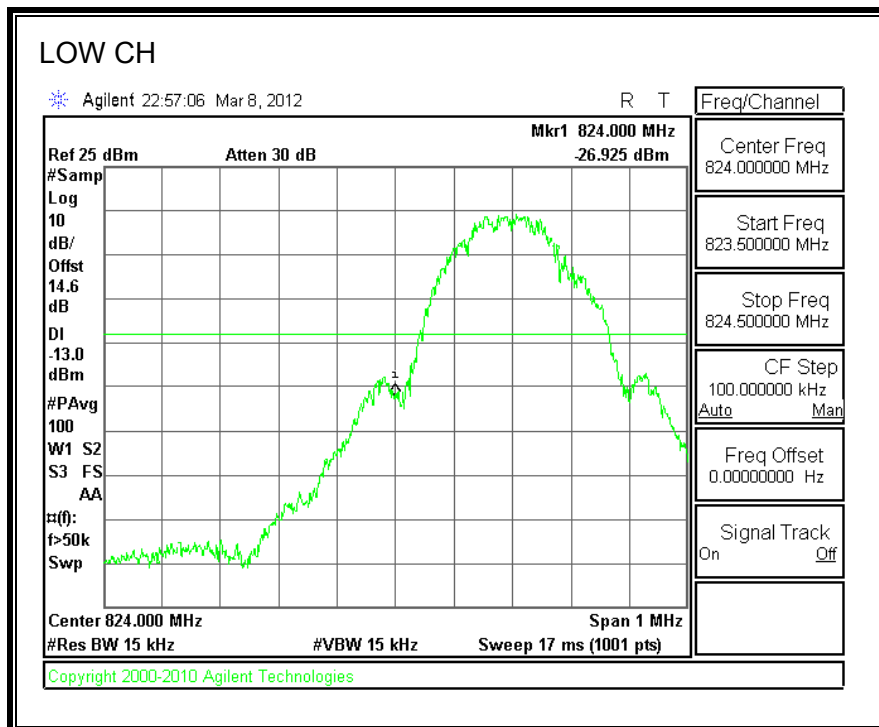

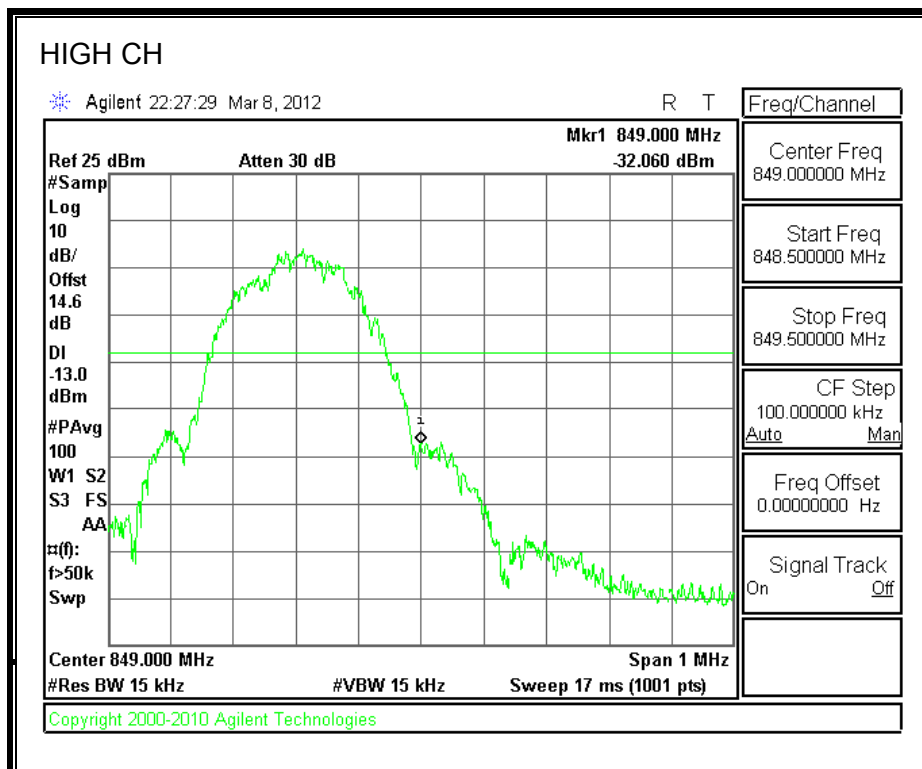
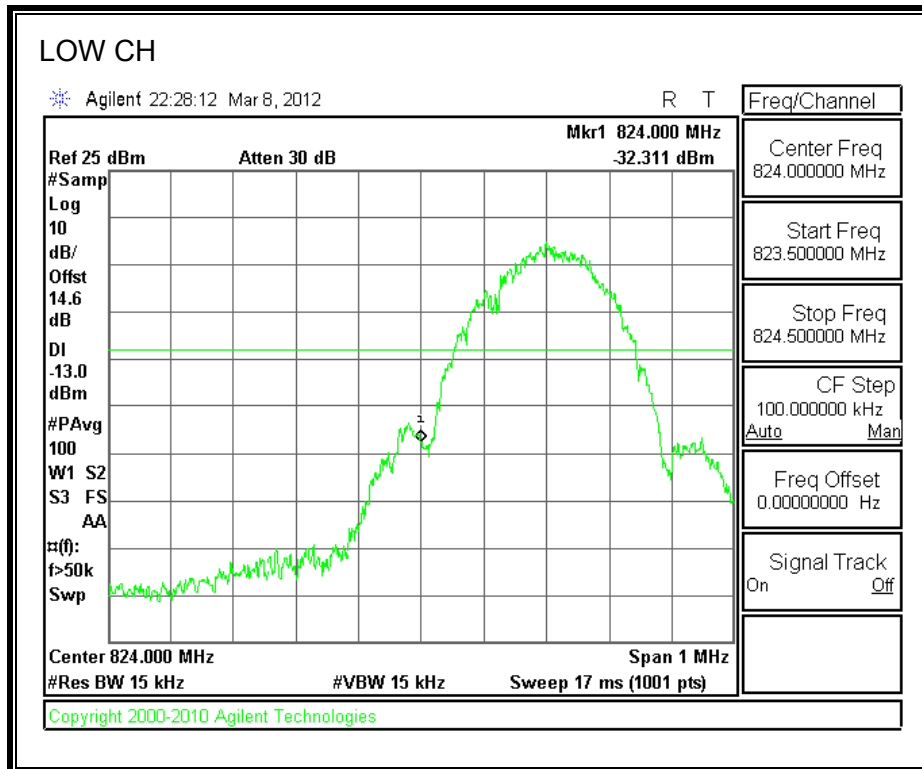

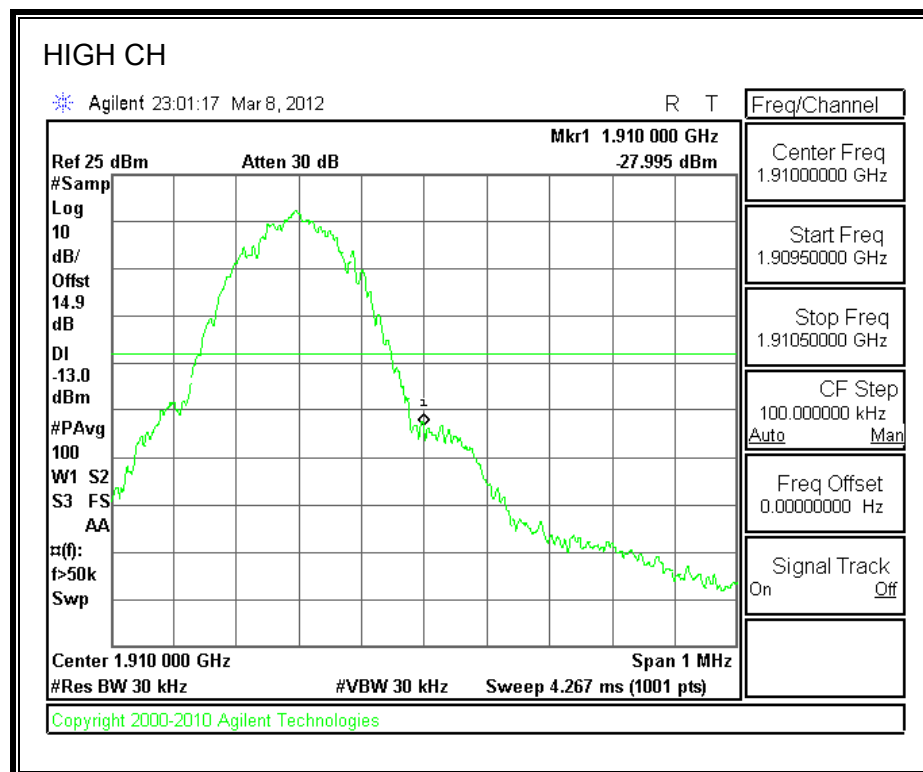
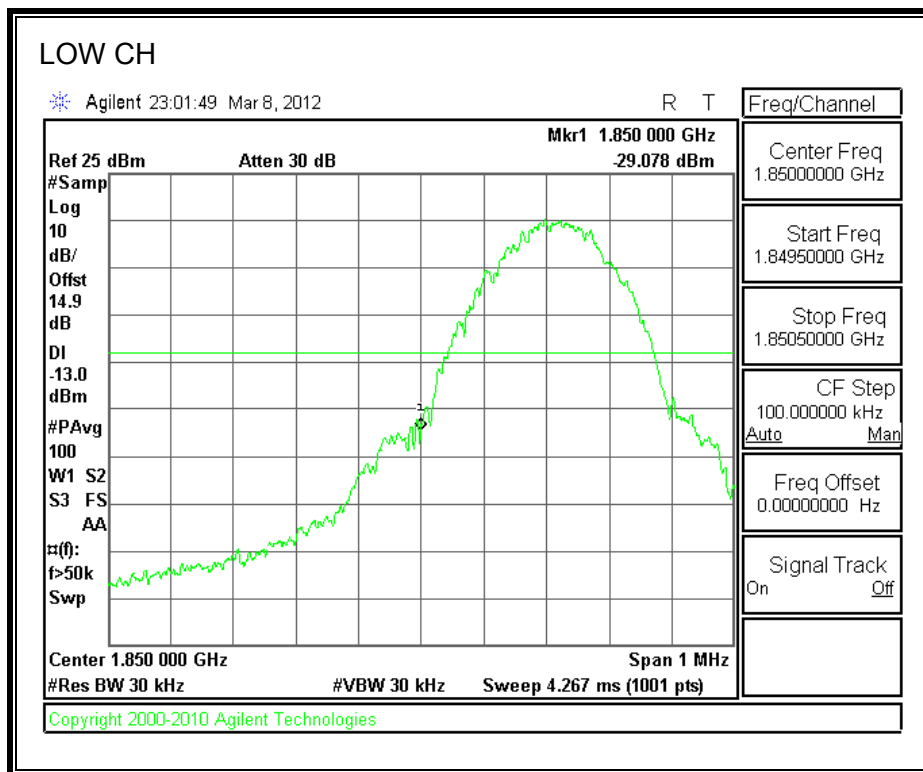

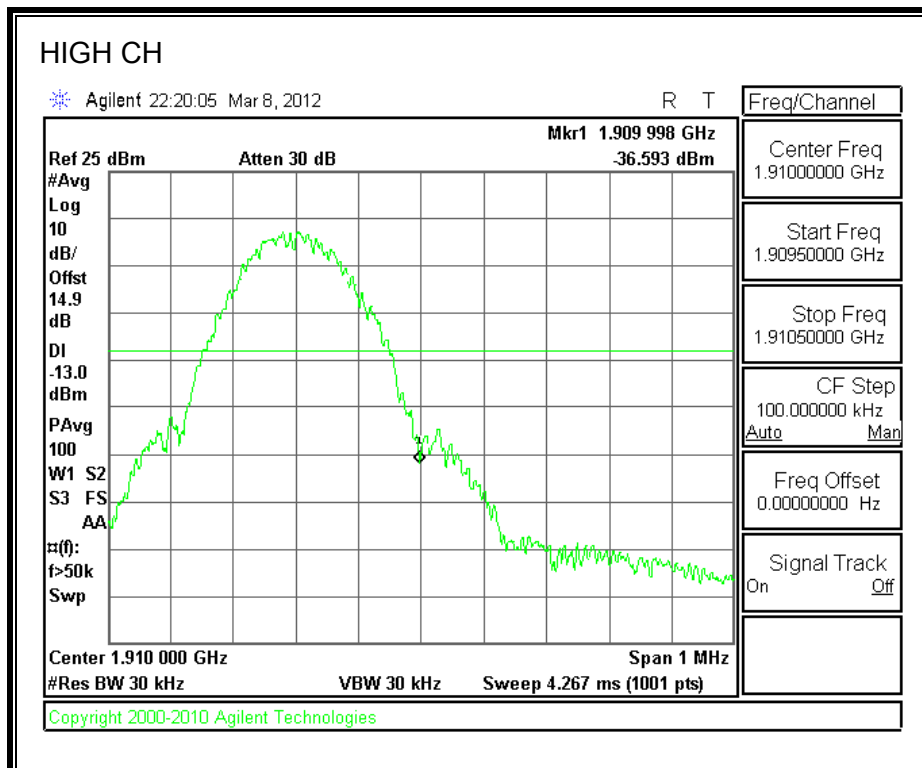
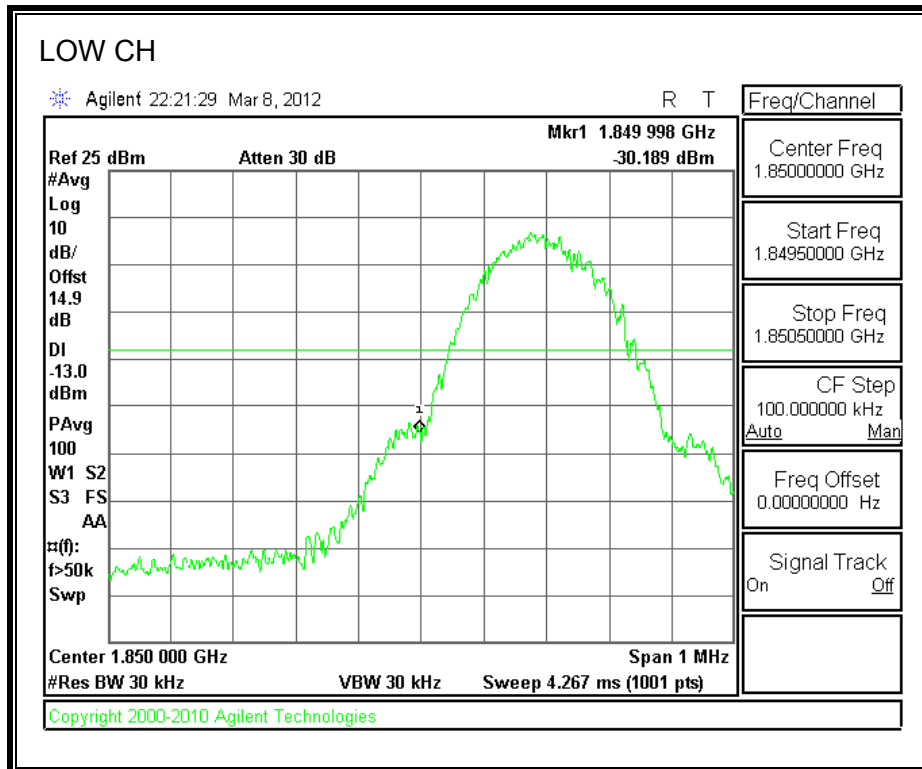

CDMA 1xRTT CELL BAND

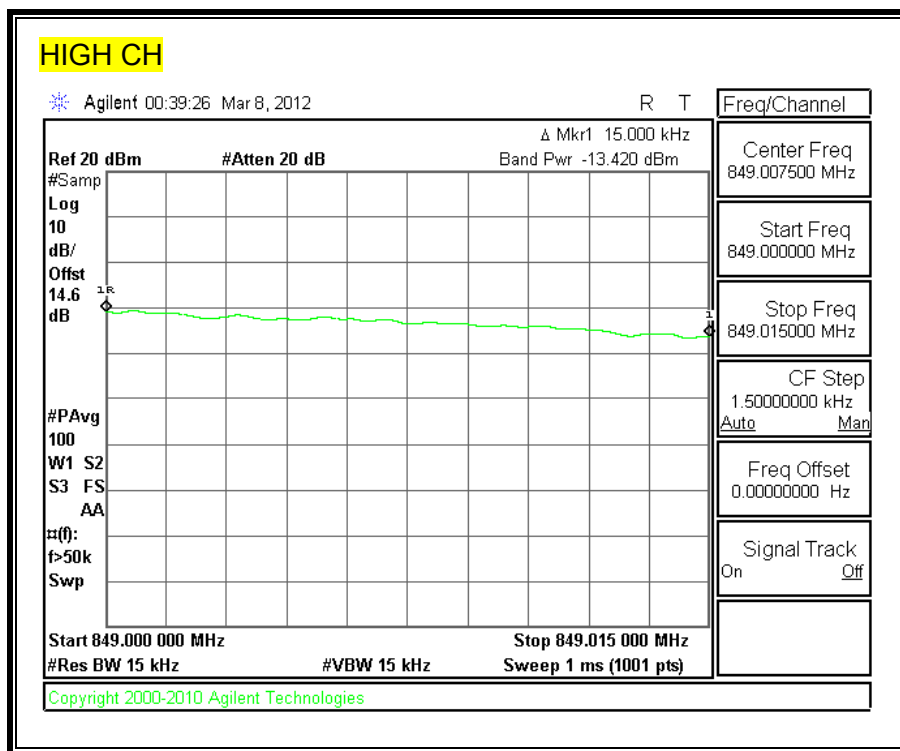
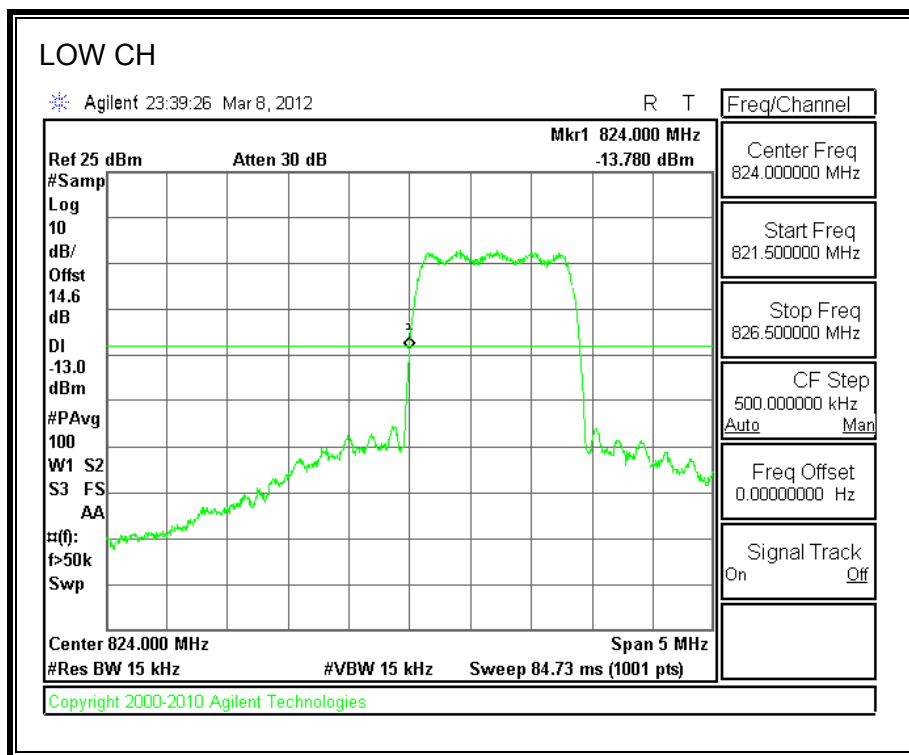

CDMA 1xRTT PCS BAND

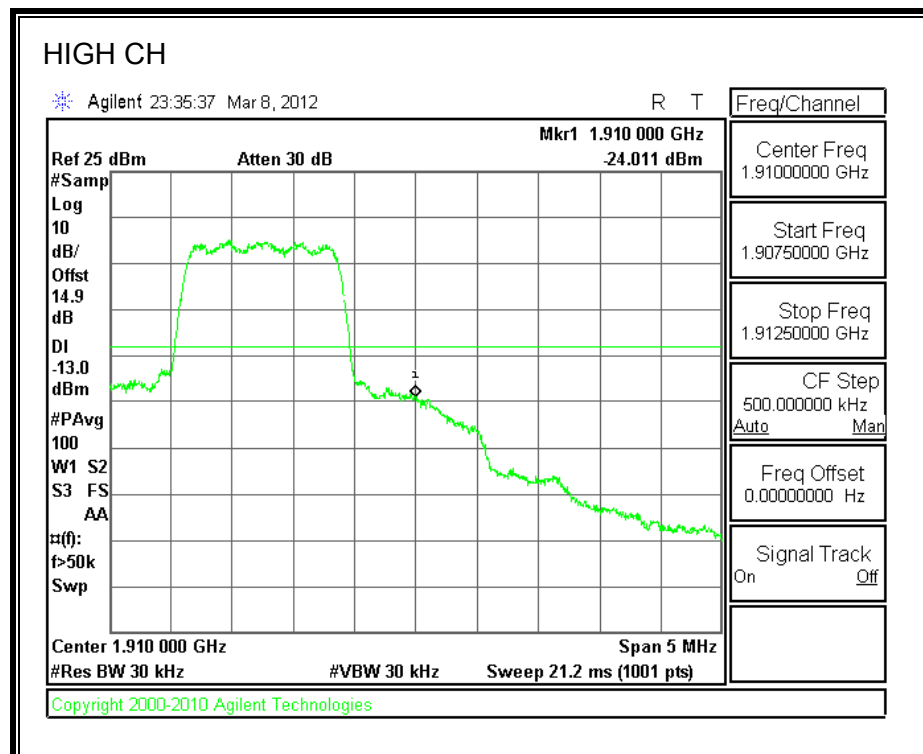
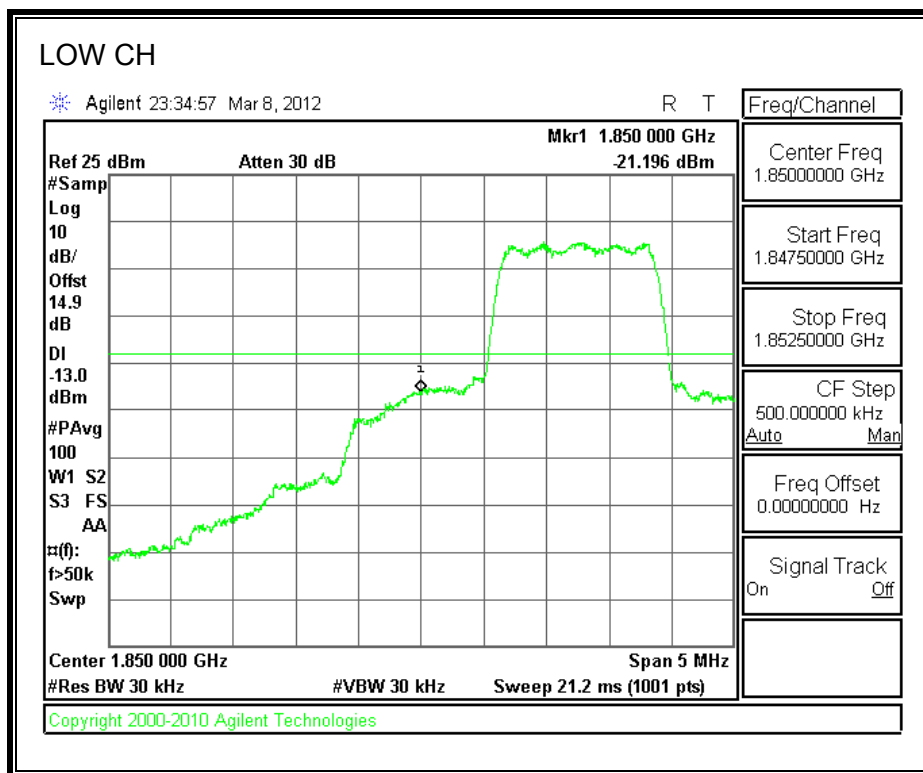

CDMA EVDO REV 0 CELL BAND

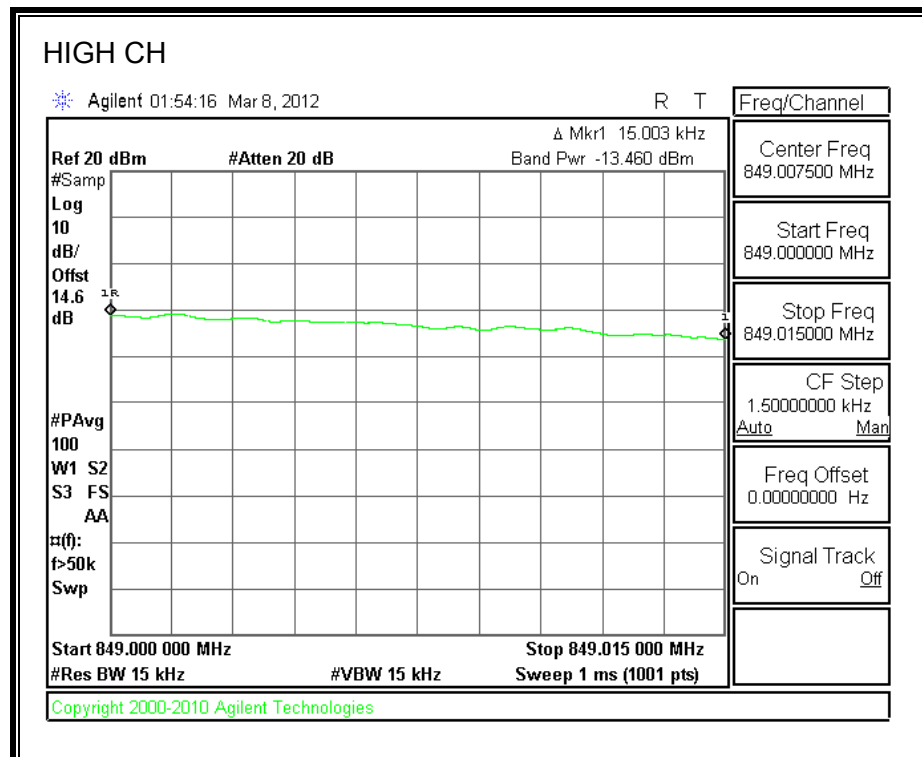
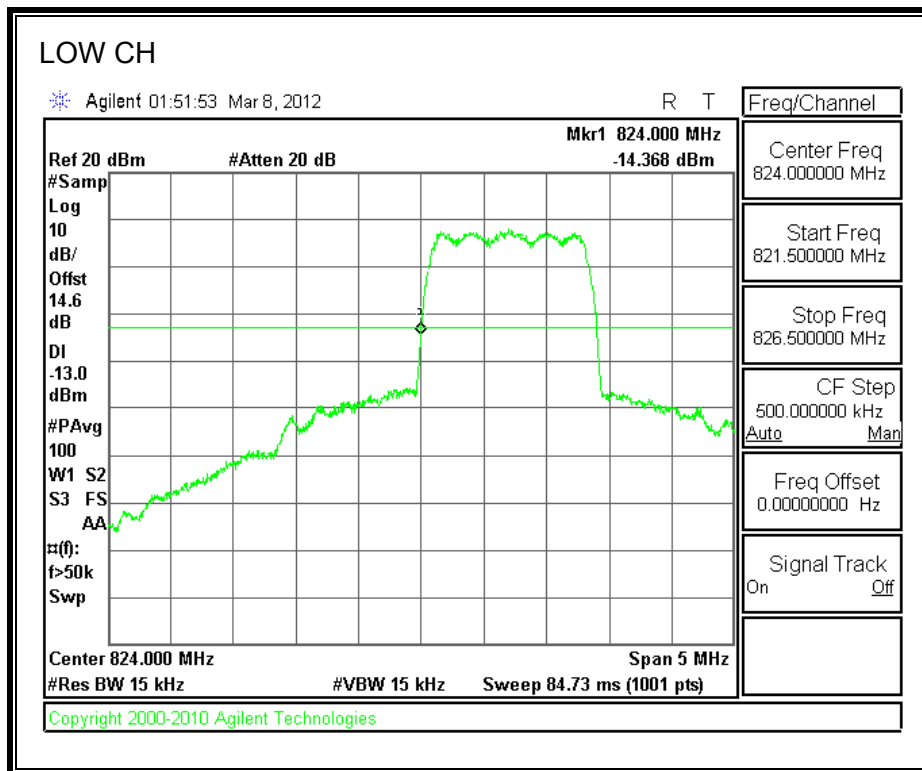

CDMA EVDO REV 0 PCS BAND

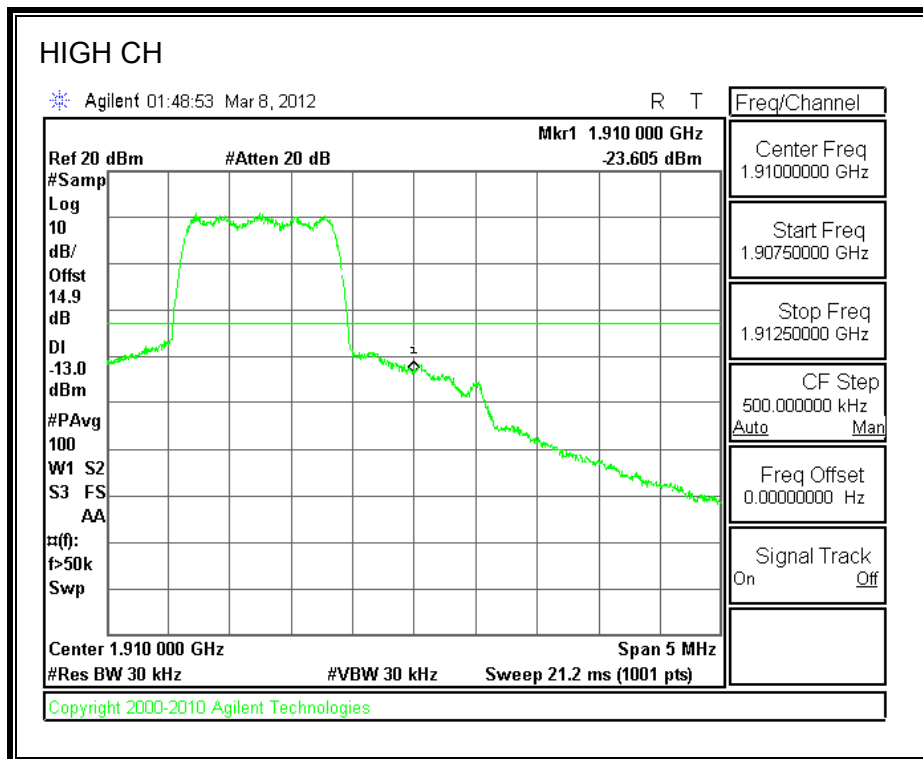
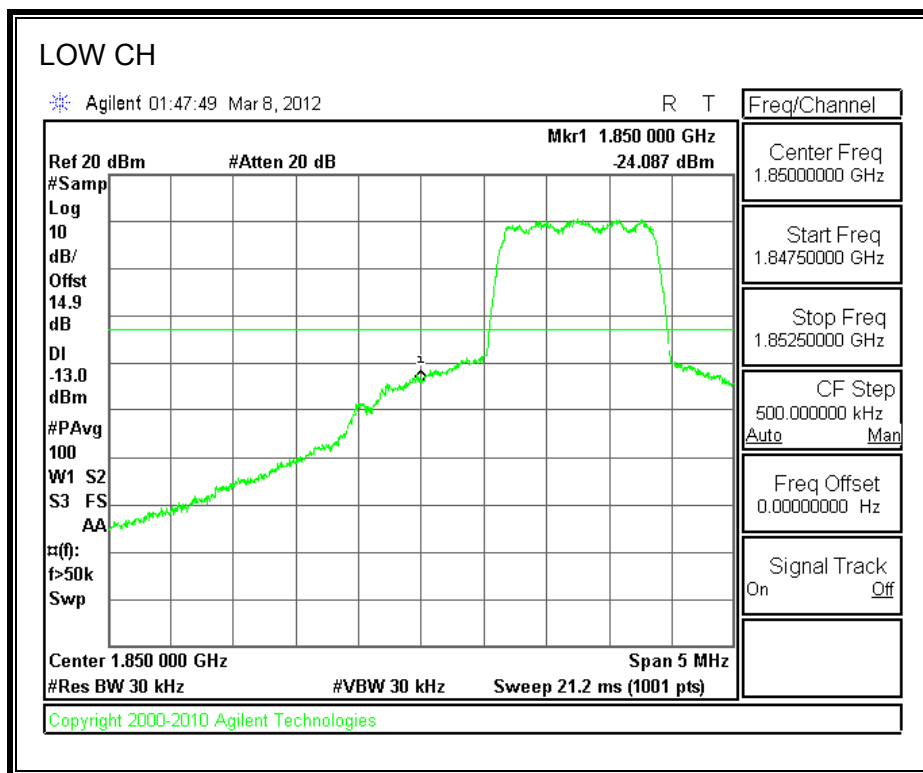

CDMA EVDO REV A CELL BAND

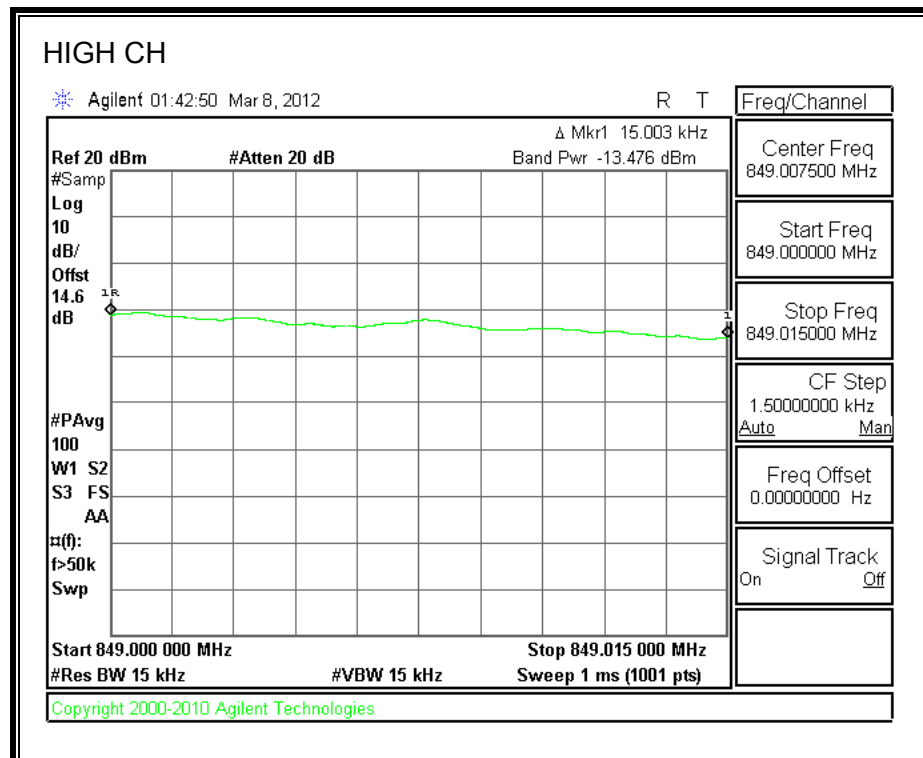
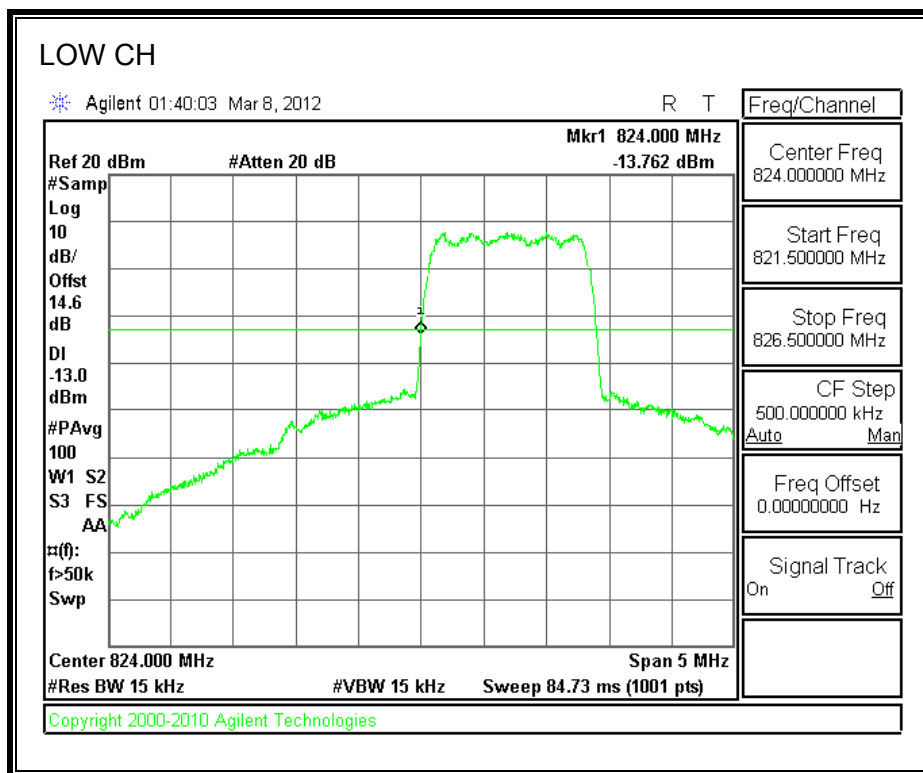

CDMA EVDO REV A PCS BAND

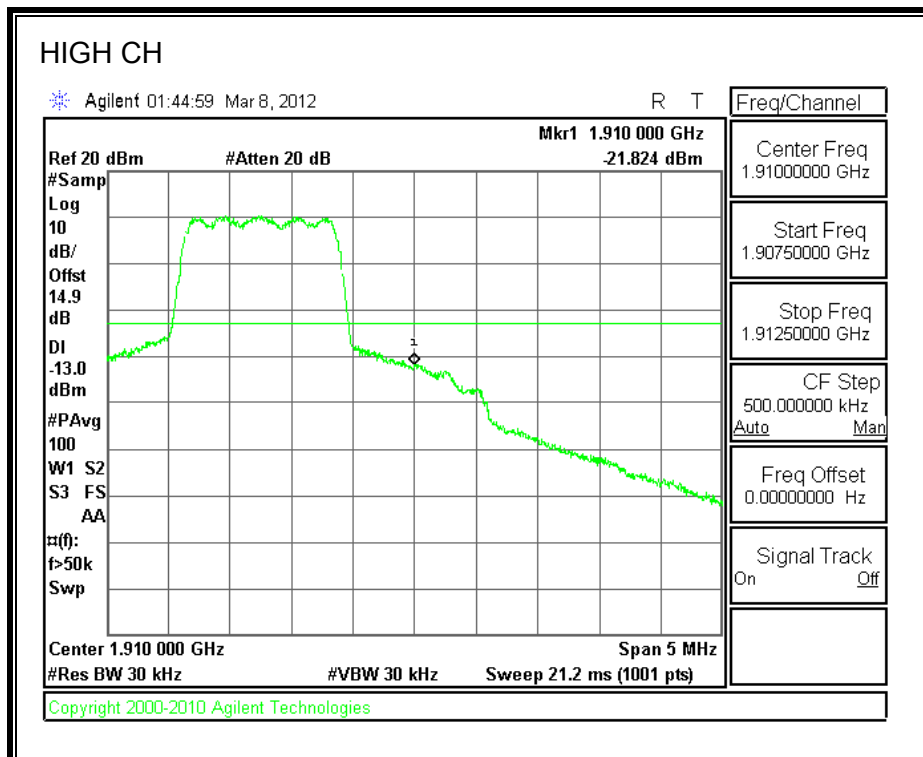
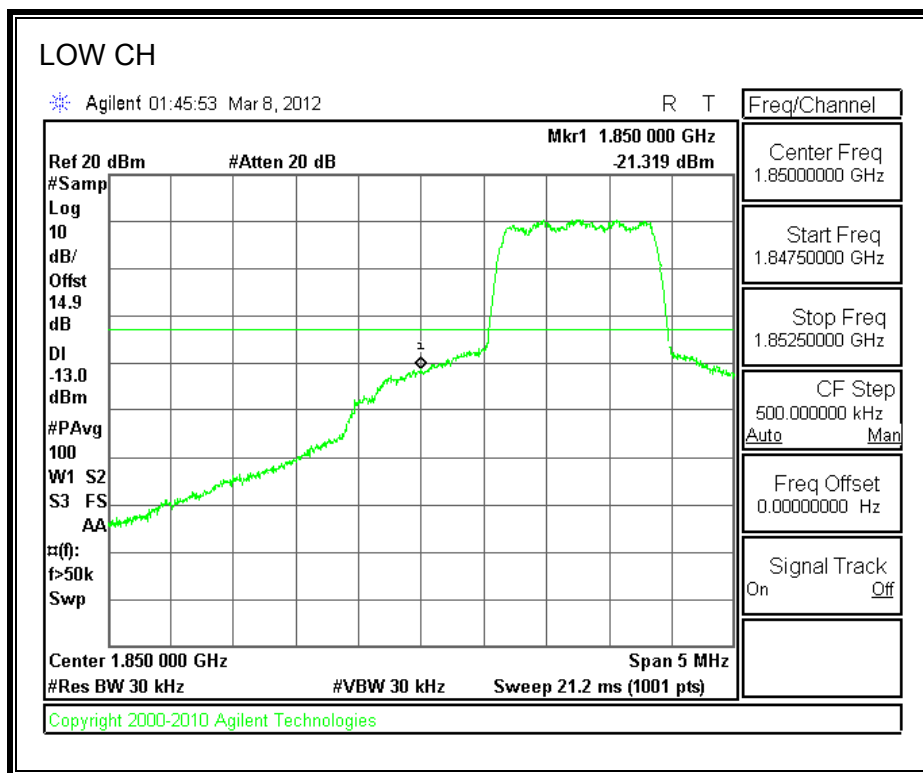

7.2. OUT OF BAND EMISSIONS

RULE PART(S)

FCC: §22.359 and 24.238
IC: RSS-132, 4.5 and RSS-133, 6.5

LIMITS

The power of any emission outside of the authorized operating frequency ranges must be attenuated below the transmitting power (P) by a factor of at least $43 + 10 \log (P)$ dB.

TEST PROCEDURE

The RF output of the transmitter was connected to a spectrum analyzer through a calibrated coaxial cable. Sufficient scans were taken to show the out-of-band Emissions, if any, up to 10th harmonic. Multiple sweeps were recorded in maximum hold mode using a peak detector to ensure that the worst-case emissions were caught.

For each out of band emissions measurement:

- Set display line at -13 dBm
- Set RBW & VBW to 100 kHz for the measurement below 1 GHz, and 1 MHz for the measurement above 1 GHz.

MODES TESTED

- GPRS and EGPRS
- CDMA 1xRTT and EVDO rev 0 & A

RESULTS

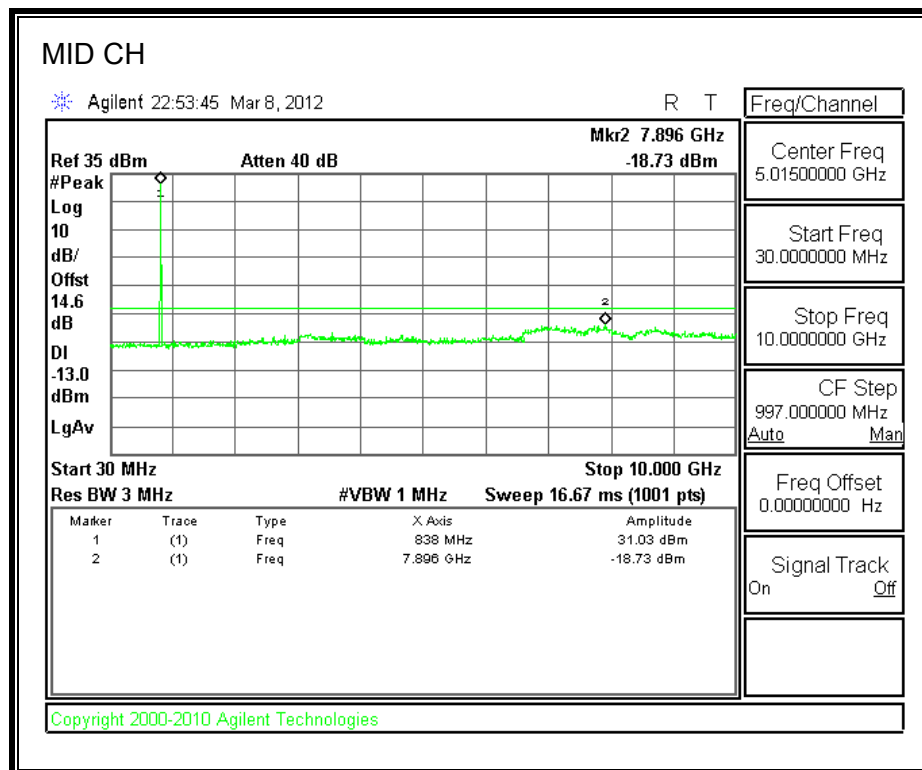
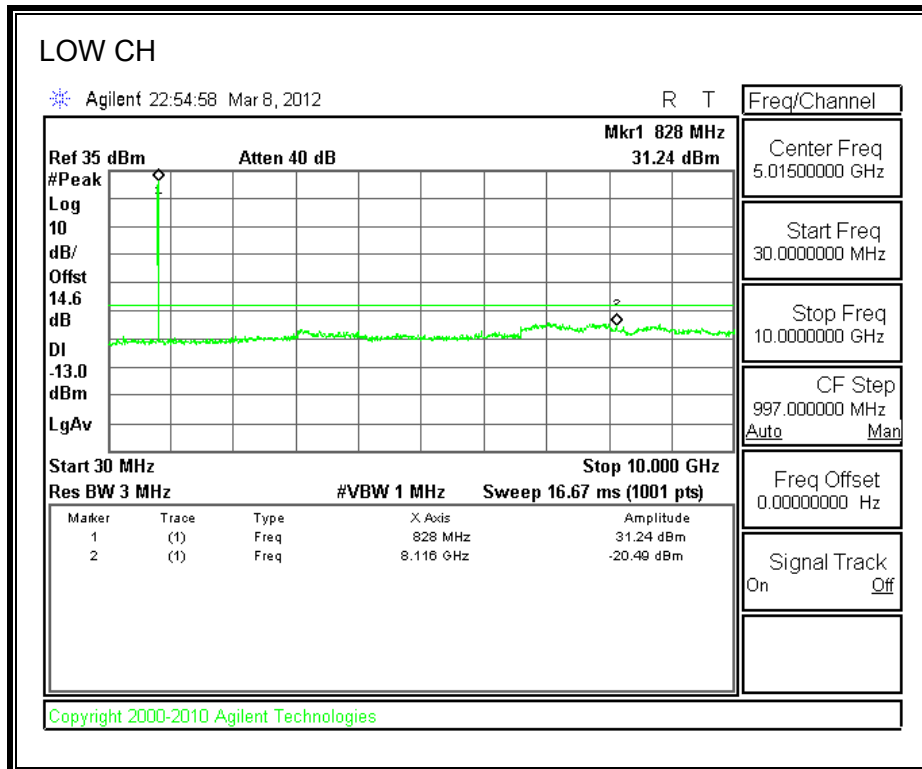

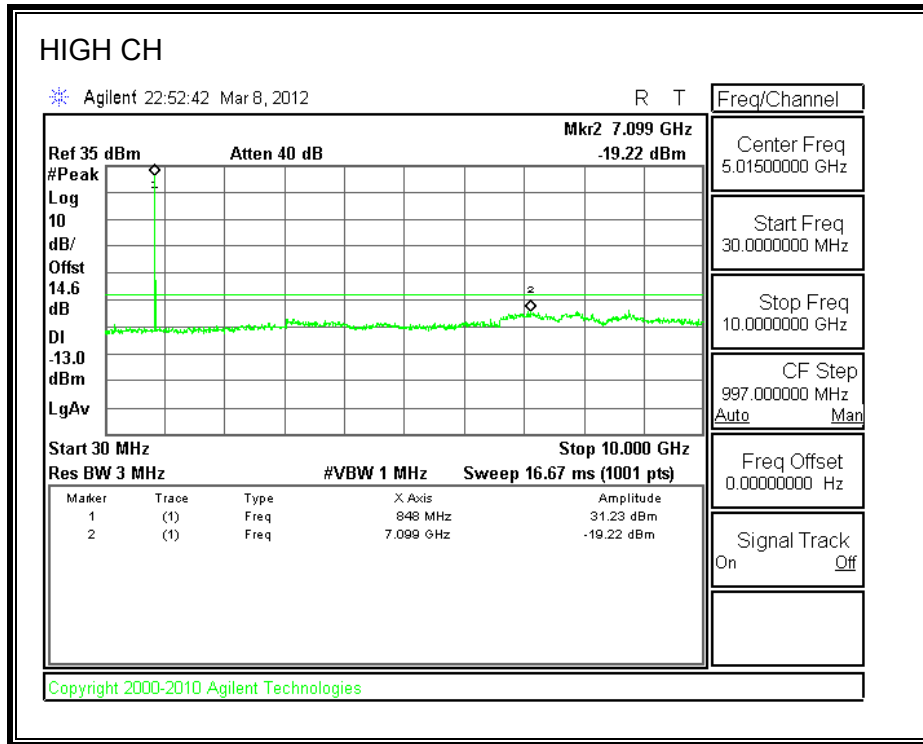

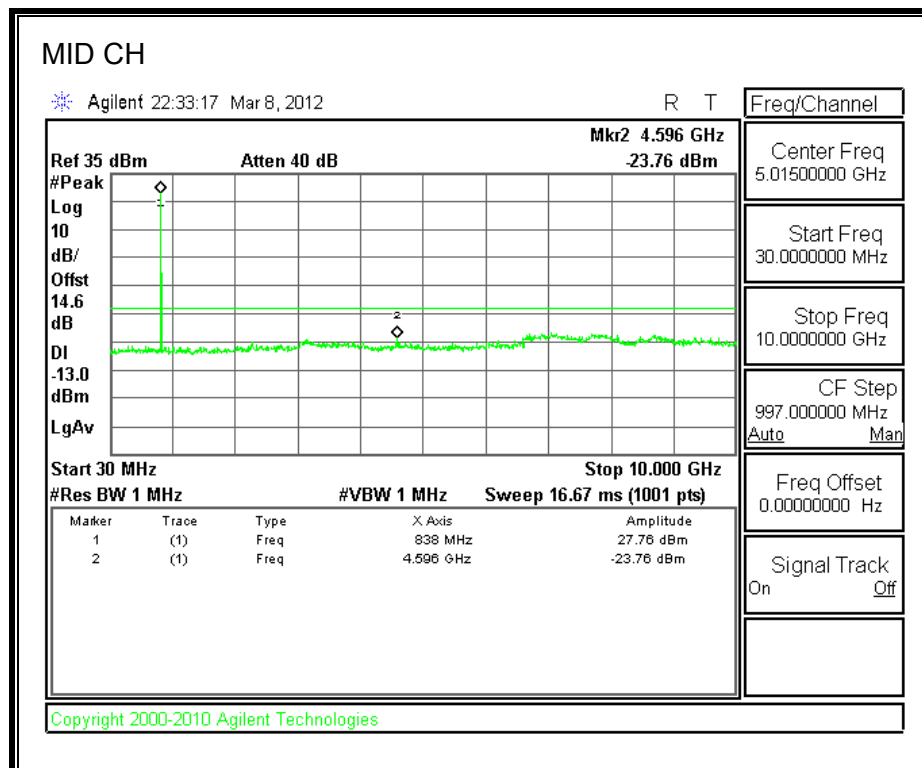
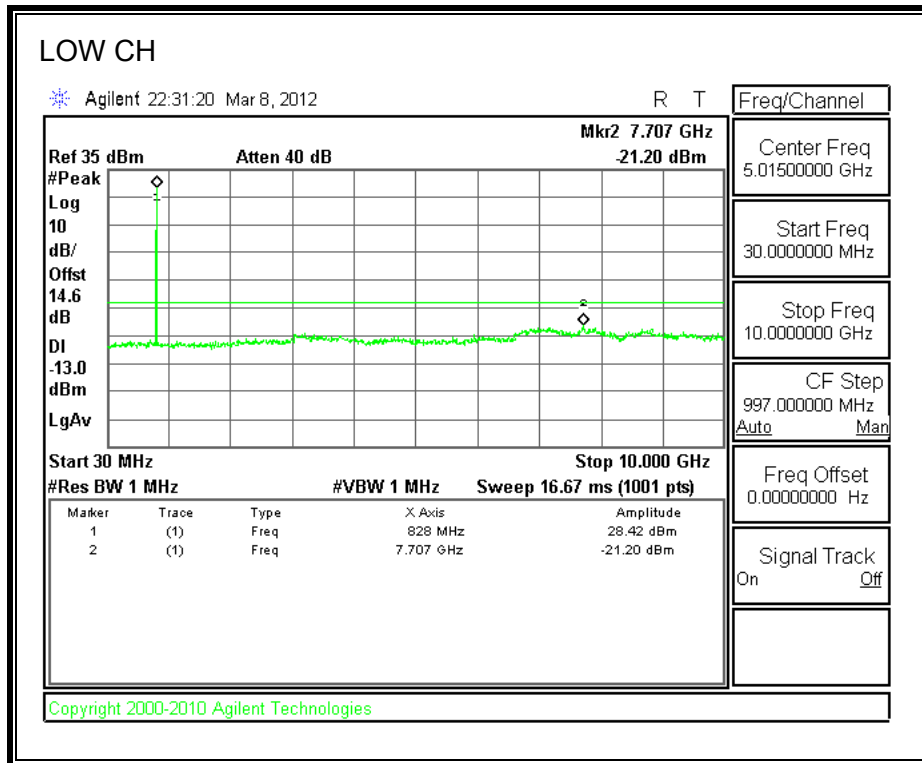

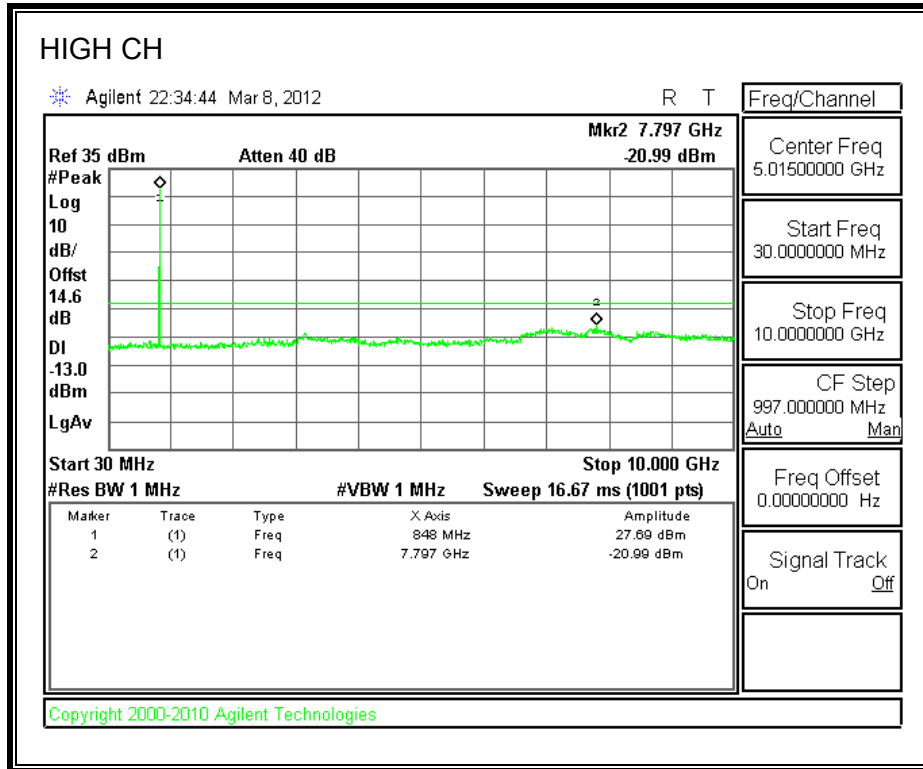

GPRS1900 BAND

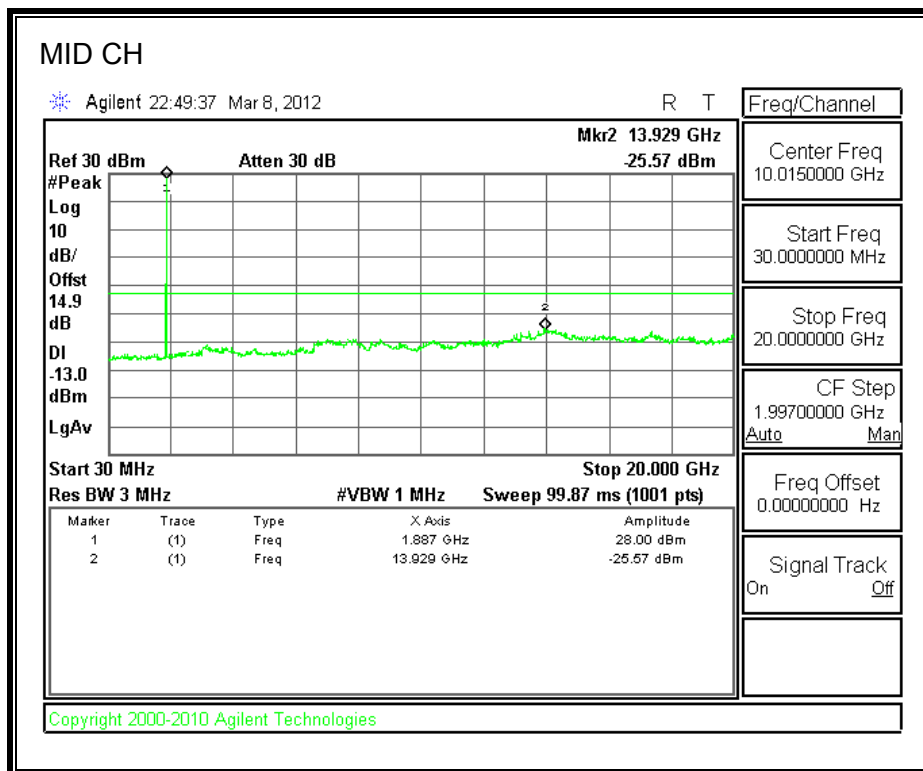
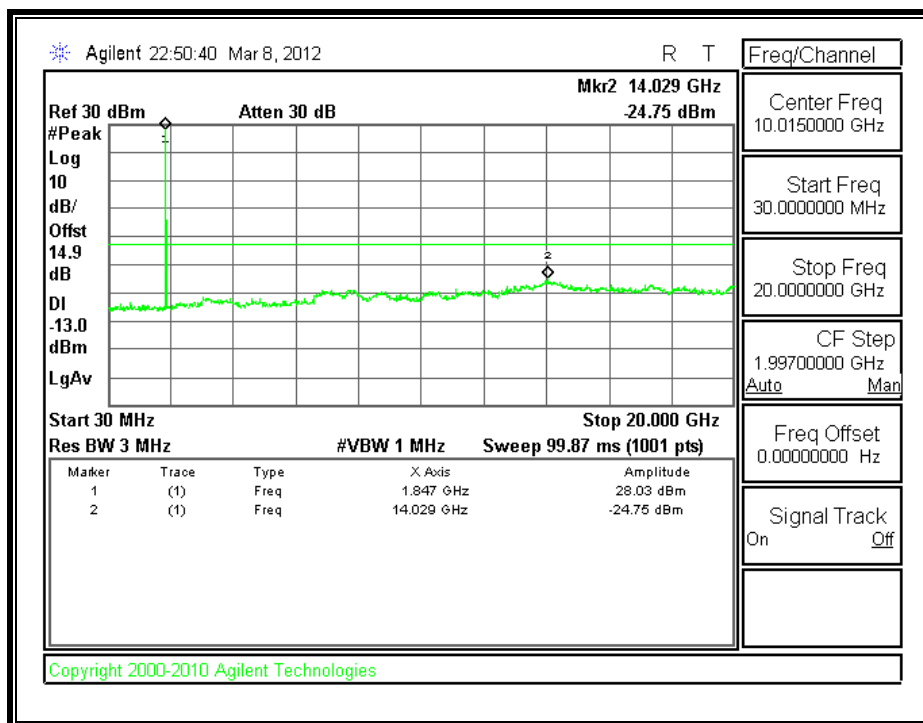

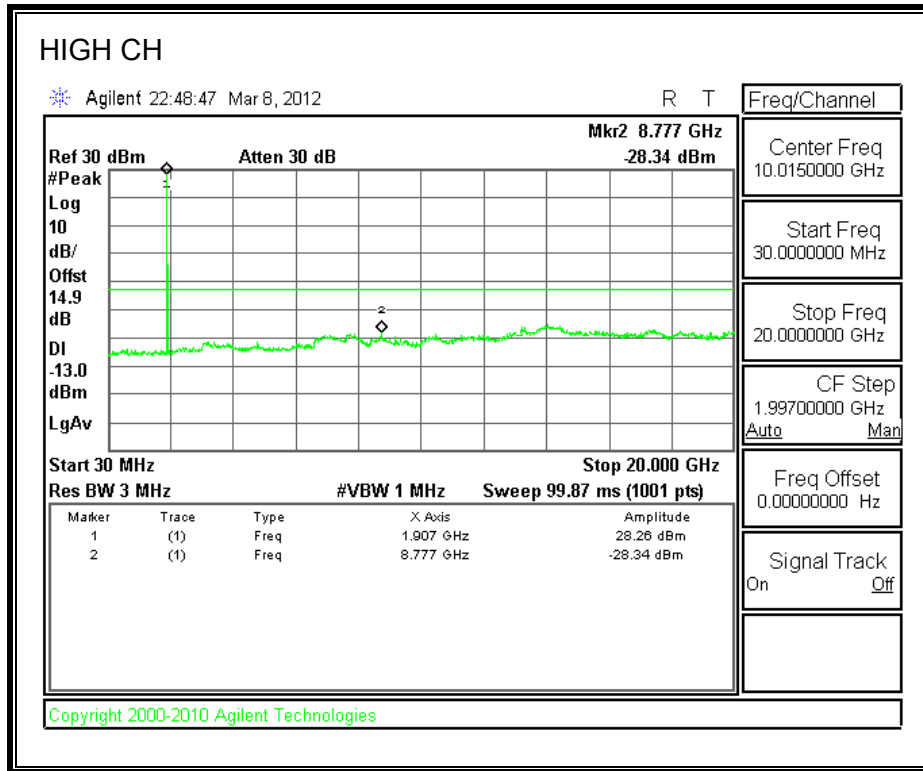

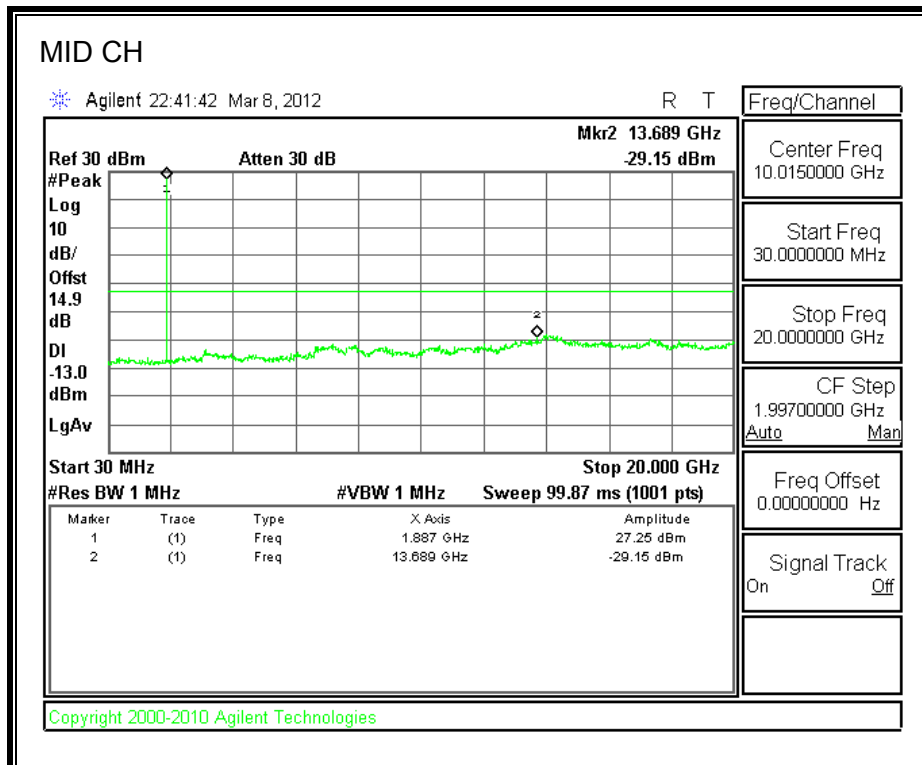
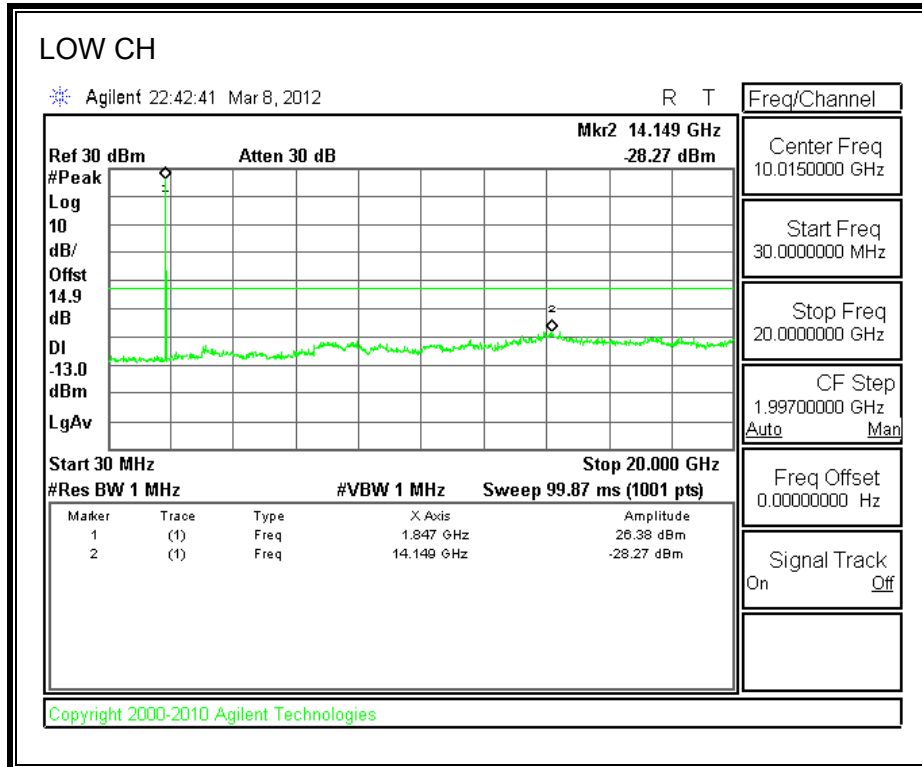

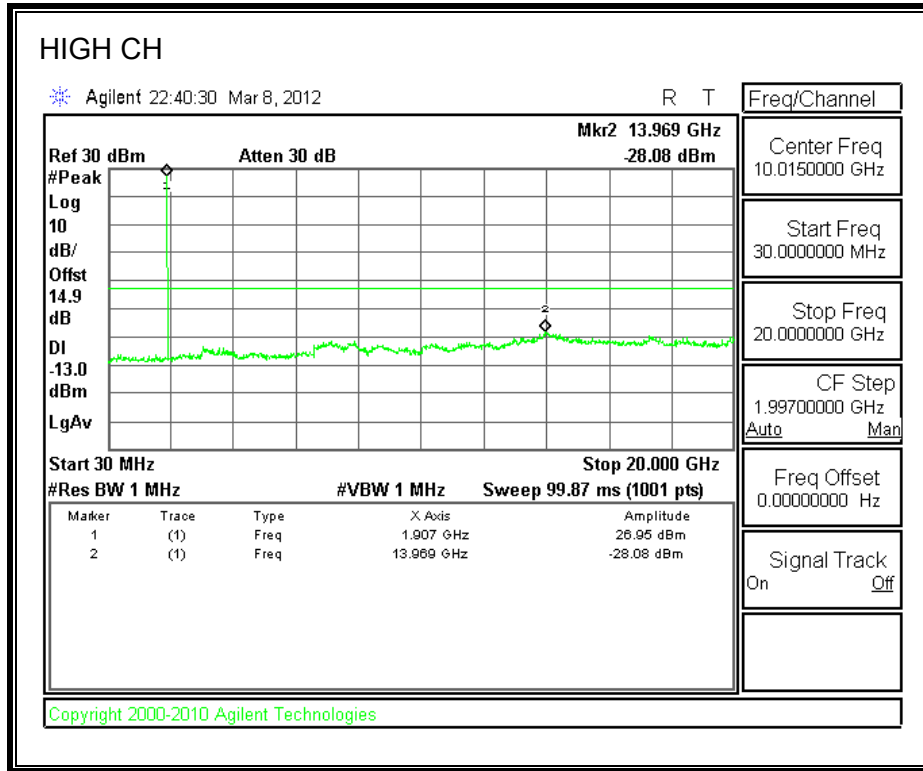

8. RADIATED TEST RESULTS

8.1 FIELD STRENGTH OF SPURIOUS RADIATION

RULE PART(S)

FCC: §2.1053, §22.917 & §24.238.
IC: RSS-132, 4.5 & RSS-233, 6.5

LIMIT

§22.917 (e) and §24.238 (a): Out of band emissions. The power of any emission outside of the authorized operating frequency ranges must be attenuated below the transmitting power (P) by a factor of at least $43 + 10 \log (P)$ dB.

TEST PROCEDURE

For Cellular equipment - Compliance with these rules is based on the use of measurement instrumentation employing a resolution bandwidth of 100 kHz or greater. In the 1 MHz bands immediately outside and adjacent to the frequency block a resolution bandwidth of at least one percent of the emission bandwidth of the fundamental emission of the transmitter may be employed. A narrower resolution bandwidth is permitted in all cases to improve measurement accuracy provided the measured power is integrated over the full required measurement bandwidth (i.e. 100 kHz or 1 percent of emission bandwidth, as specified). The emission bandwidth is defined as the width of the signal between two points, one below the carrier center frequency and one above the carrier center frequency, outside of which all emissions are attenuated at least 26 dB below the transmitter power.

For PCS equipment - Compliance with these rules is based on the use of measurement instrumentation employing a resolution bandwidth of 1 MHz or greater. However, in the 1 MHz bands immediately outside and adjacent to the frequency block a resolution bandwidth of at least one percent of the emission bandwidth of the fundamental emission of the transmitter may be employed. A narrower resolution bandwidth is permitted in all cases to improve measurement accuracy provided the measured power is integrated over the full required measurement bandwidth (i.e. 1 MHz or 1 percent of emission bandwidth, as specified). The emission bandwidth is defined as the width of the signal between two points, one below the carrier center frequency and one above the carrier center frequency, outside of which all emissions are attenuated at least 26 dB below the transmitter power.

MODES TESTED

- GPRS and EGPRS
- CDMA 1xRTT and EVDO rev 0 & A

RESULTS

ERP GPRS850 BAND

Compliance Certification Services Above 1GHz High Frequency Substitution Measurement									
Company:		Samsung							
Project #:		12114311							
Date:		02/29/12							
Test Engineer:		Chin Pang							
Configuration:		EUT and AC Adapter							
Mode:		TX, CELL BAND GPRS MODE							
Chamber		Pre-amplifier		Filter		Limit			
5m Chamber A		T144 8449B		Filter 1		Part 22			
f GHz	SG reading (dBm)	Ant. Pol. (H/V)	Distance (m)	Preamp (dB)	Filter (dB)	ERP (dBm)	Limit (dBm)	Delta (dB)	Notes
Low Ch, (824.2MHz)									
1.648	-8.4	V	3.0	38.2	1.0	-45.5	-13.0	-32.5	
2.473	-1.9	V	3.0	37.5	1.0	-38.4	-13.0	-25.4	
3.297	-6.3	V	3.0	37.1	1.0	-42.4	-13.0	-29.4	
4.121	-8.2	V	3.0	36.5	1.0	-43.7	-13.0	-30.7	
6.594	-17.3	V	3.0	36.4	1.0	-52.7	-13.0	-39.7	
1.648	-18.6	H	3.0	38.2	1.0	-55.8	-13.0	-42.8	
2.473	-5.9	H	3.0	37.5	1.0	-42.4	-13.0	-29.4	
3.297	-7.6	H	3.0	37.1	1.0	-43.7	-13.0	-30.7	
4.121	-10.0	H	3.0	36.5	1.0	-45.5	-13.0	-32.5	
Mid Ch, (836.6MHz)									
1.673	-15.4	V	3.0	38.1	1.0	-52.6	-13.0	-39.6	
2.510	-3.2	V	3.0	37.5	1.0	-39.6	-13.0	-26.6	
3.346	-7.3	V	3.0	37.1	1.0	-43.4	-13.0	-30.4	
4.183	-12.5	V	3.0	36.5	1.0	-48.0	-13.0	-35.0	
6.693	-18.1	V	3.0	36.4	1.0	-53.6	-13.0	-40.6	
1.673	-21.6	H	3.0	38.1	1.0	-58.8	-13.0	-45.8	
2.510	-7.1	H	3.0	37.5	1.0	-43.5	-13.0	-30.5	
3.346	-10.5	H	3.0	37.1	1.0	-46.6	-13.0	-33.6	
4.183	-8.6	H	3.0	36.5	1.0	-44.1	-13.0	-31.1	
High Ch, (848.8MHz)									
1.698	-18.5	V	3.0	38.1	1.0	-55.6	-13.0	-42.6	
2.546	-1.9	V	3.0	37.5	1.0	-38.4	-13.0	-25.4	
3.395	-10.8	V	3.0	37.1	1.0	-46.8	-13.0	-33.8	
4.244	-7.8	V	3.0	36.5	1.0	-43.3	-13.0	-30.3	
6.790	-17.1	V	3.0	36.5	1.0	-52.6	-13.0	-39.6	
1.698	-21.5	H	3.0	38.1	1.0	-58.6	-13.0	-45.6	
2.546	-10.7	H	3.0	37.5	1.0	-47.2	-13.0	-34.2	
3.395	-8.6	H	3.0	37.1	1.0	-44.6	-13.0	-31.6	
4.244	-10.9	H	3.0	36.5	1.0	-46.4	-13.0	-33.4	
Rev. 03.03.09									
Note: No other emissions were detected above the system noise floor.									

EIRP GPRS1900 BAND

Compliance Certification Services Above 1GHz High Frequency Substitution Measurement									
Company:		SIERRA WIRELESS							
Project #:		11U14140							
Date:		03/08/12							
Test Engineer:		MENGISTU MEKURIA							
Configuration:		EUT and AC Adapter							
Mode:		TX, PCS BAND GPRS							
Chamber		Pre-amplifier			Filter		Limit		
5m Chamber A		T144 8449B			Filter 1		Part 24		
f GHz	SG reading (dBm)	Ant. Pol. (H/V)	Distance (m)	Preamp (dB)	Filter (dB)	EIRP (dBm)	Limit (dBm)	Delta (dB)	Notes
Low Ch, (1851.25MHz)									
3.700	-8.4	V	3.0	36.8	1.0	-44.2	-13.0	-31.2	
7.401	-14.2	V	3.0	36.6	1.0	-49.8	-13.0	-36.8	
3.700	-11.2	H	3.0	36.8	1.0	-47.0	-13.0	-34.0	
Mid Ch, (1880.0MHz)									
3.760	-10.3	V	3.0	36.8	1.0	-46.0	-13.0	-33.0	
7.520	-14.3	V	3.0	36.6	1.0	-50.0	-13.0	-37.0	
3.760	-10.6	H	3.0	36.8	1.0	-46.4	-13.0	-33.4	
High Ch, (1908.75MHz)									
3.820	-10.7	V	3.0	36.7	1.0	-46.4	-13.0	-33.4	
7.639	-14.1	V	3.0	36.6	1.0	-49.8	-13.0	-36.8	
3.820	-11.5	H	3.0	36.7	1.0	-47.2	-13.0	-34.2	
Rev. 03.03.09									
Note: No other emissions were detected above the system noise floor.									

8.2. RECEIVER SPURIOUS EMISSIONS

RULE PART(S)

FCC: N/A

IC: RSS-132, 4.6; RSS-133, 6.6, RSS-Gen, RSS-139, 6.6, RSS-Gen

LIMIT

RSS-Gen 6 (a) - If a radiated measurement is made, all spurious emissions shall comply with the limits of Table 1

Spurious Emission Limits for Receivers:

Spurious Frequency (MHz)	Field Strength (microvolts/m at 3 metres)
30-88	100
88-216	150
216-960	200
Above 960	500

TEST PROCEDURE

The search for spurious emissions shall be from the lowest frequency internally generated or used in the receiver (local oscillator frequency, intermediate frequency or carrier frequency), or 30 MHz, whichever is the higher, to at least 3 times the highest tunable and local oscillator frequencies.

RESULTS

RECEIVER SPURIOUS EMISSIONS FOR 30 TO 1000 MHz, HORIZONTAL

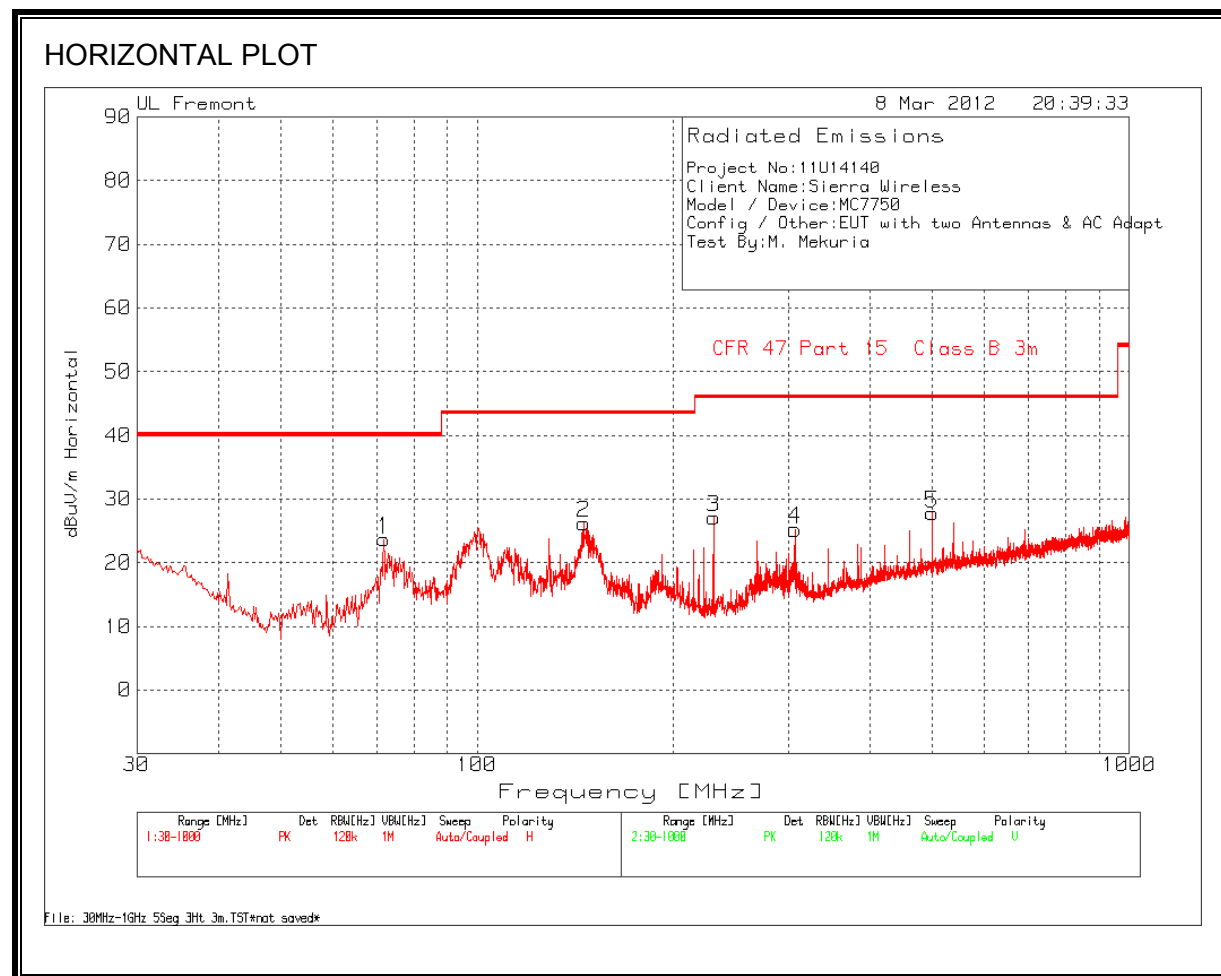

RECEIVER SPURIOUS EMISSIONS FOR 30 TO 1000 MHz, VERTICAL

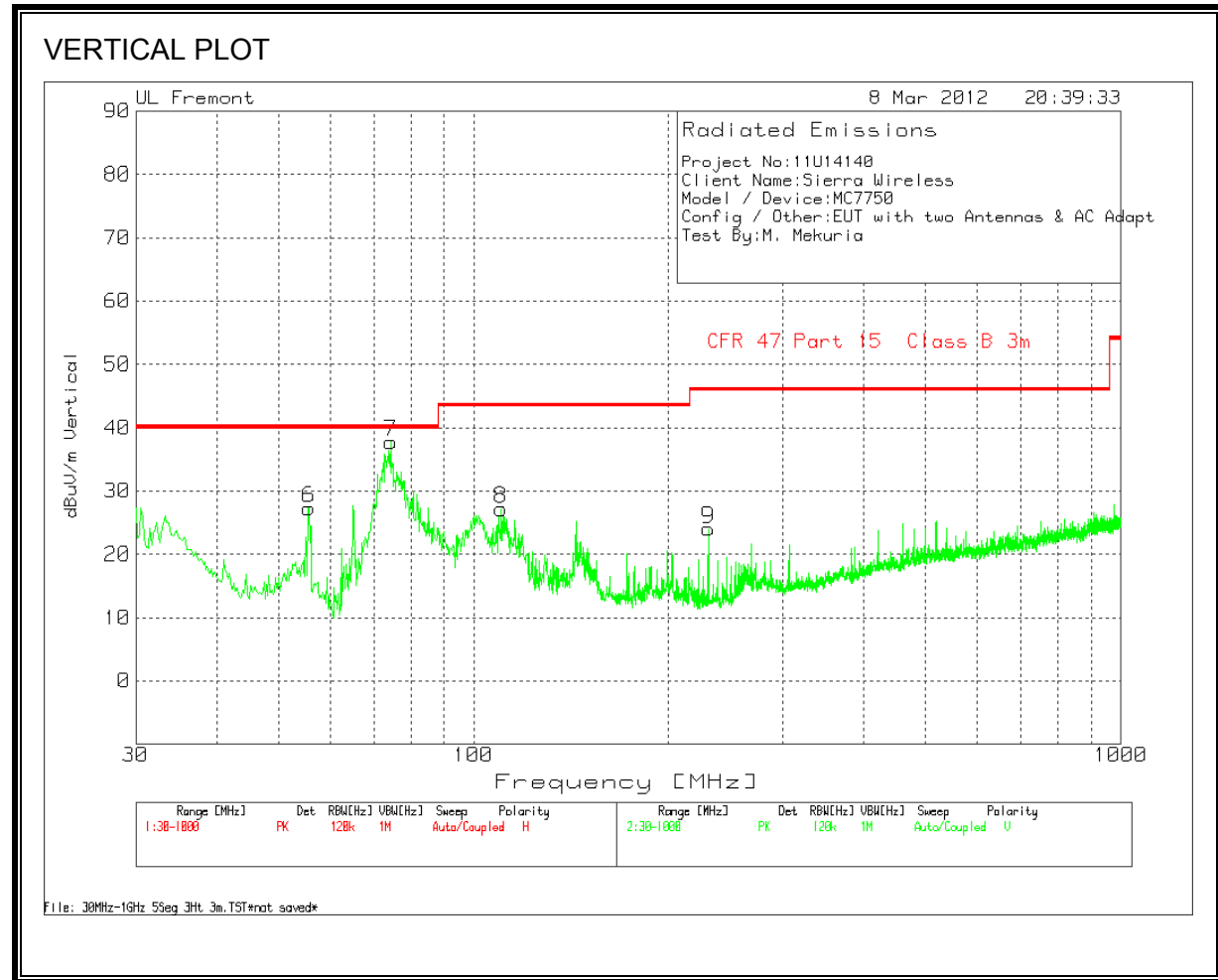

HORIZONTAL AND VERTICAL DATA

Project No:11U14140									
Client Name:Sierra Wireless									
Model / Device:MC7750									
Config / Other:EUT with two Antennas & AC Adapt									
Test By:M. Mekuria									
Range 1 30 - 1000MHz									
Test Frequency	Meter Reading	Detector	25MHz-1GHz ChmbrA Amplified.TX [dB]	T243 Sunol Bilog.TXT [dB]	dBuV/m	CFR 47 Part 15 Class B 3m	Margin	Height [cm]	Polarity
71.8705	42.68	PK	-27.1	8.1	23.68	40	-16.32	300	Horz
145.5316	40.45	PK	-26.6	12.4	26.25	43.5	-17.25	200	Horz
230.4357	42.32	PK	-26.1	10.9	27.12	46	-18.88	91	Horz
307.1982	37.66	PK	-25.8	13.4	25.26	46	-20.74	91	Horz
499.2986	35.08	PK	-24.8	17.5	27.78	46	-18.22	200	Horz
Range 2 30 - 1000MHz									
Test Frequency	Meter Reading	Detector	25MHz-1GHz ChmbrA Amplified.TX [dB]	T243 Sunol Bilog.TXT [dB]	dBuV/m	CFR 47 Part 15 Class B 3m	Margin	Height [cm]	Polarity
55.5875	47.52	PK	-27.3	7.1	27.32	40	-12.68	200	Vert
74.3905	56.85	PK	-27.1	8	37.75	40	-2.25	100	Vert
110.2518	41.1	PK	-26.7	12.8	27.2	43.5	-16.3	100	Vert
230.4357	39.23	PK	-26.1	10.9	24.03	46	-21.97	100	Vert

RECEIVER SPURIOUS EMISSIONS ABOVE 1000 MHz

High Frequency Measurement																	
Compliance Certification Services, Fremont 5m Chamber-A																	
Company:		SIERRA WIRELESS															
Project #:		11U14140															
Date:		03/08/12															
Test Engineer:		MENGISTU MEKURIA															
Configuration:		EUT and AC Adapter															
Mode:		RX MODE															
Test Equipment:																	
Horn 1-18GHz			Pre-amplifier 1-26GHz			Pre-amplifier 26-40GHz			Horn > 18GHz			Limit					
T73; S/N: 6717 @3m			T144 Miteq 3008A00931									FCC 15.209					
Hi Frequency Cables																	
3' cable 22807700			12' cable 22807600			20' cable 22807500			HPF		Reject Filter		Peak Measurements RBW=VBW=1MHz				
3' cable 22807700			12' cable 22807600			20' cable 22807500							Average Measurements RBW=1MHz ; VBW=10Hz				
f GHz	Dist (m)	Read Pk dBuV	Read Avg. dBuV	AF dB/m	CL dB	Amp dB	D Corr dB	Filtr dB	Peak dBuV/m	Avg dBuV/m	Pk Lim dBuV/m	Avg Lim dBuV/m	Pk Mar dB	Avg Mar dB	Notes (V/H)		
1.960	3.0	48.2	45.2	27.3	3.8	-37.5	0.0	0.0	41.7	38.7	74	54	-32.3	-15.3	V		
1.960	3.0	44.6	41.6	27.3	3.8	-37.5	0.0	0.0	38.1	35.1	74	54	-35.9	-18.9	H		
Rev. 11.10.11																	
f	Measurement Frequency					Amp	Preamp Gain					Avg Lim	Average Field Strength Limit				
Dist	Distance to Antenna					D Corr	Distance Correct to 3 meters					Pk Lim	Peak Field Strength Limit				
Read	Analyzer Reading					Avg	Average Field Strength @ 3 m					Avg Mar	Margin vs. Average Limit				
AF	Antenna Factor					Peak	Calculated Peak Field Strength					Pk Mar	Margin vs. Peak Limit				
CL	Cable Loss					HPF	High Pass Filter										

9. FREQUENCY STABILITY

RULE PART(S)

FCC: §22.359 and 24.238

IC: RSS-132, 4.5 and RSS-133, 6.5

LIMITS

§22.355 & RSS-132 4.3 - The carrier frequency shall not depart from the reference frequency in excess of ± 2.5 ppm for mobile stations.

RSS-133 6.3 - The carrier frequency shall not depart from the reference frequency in excess of ± 2.5 ppm for mobile stations.

§24.235 - The frequency stability shall be sufficient to ensure that the fundamental emission stays within the authorized frequency block.

TEST PROCEDURE

Use Agilent 8960 and CMW 500 with Frequency Error measurement capability.

- Temp. = -20° to $+50^{\circ}$ C
- Voltage = 115 Vac (85% - 115%)
-

Frequency Stability vs Temperature:

The EUT is placed inside a temperature chamber. The temperature is set to 20° C and allowed to stabilize. After sufficient soak time, the transmitting frequency error is measured. The temperature is increased by 10 degrees, allowed to stabilize and soak, and then the measurement is repeated. This is repeated until $+50^{\circ}$ C is reached.

Frequency Stability vs Voltage:

The peak frequency error is recorded (worst-case).

MODES TESTED

- GPRS and EGPRS
- CDMA 1xRTT and EVDO rev 0 & A

RESULTS

See the following pages.

CELL, GSM MODULATION – MID CHANNEL

Reference Frequency: Cellular Mid Channel 836.600004MHz @ 20°C Limit: to stay +/- 2.5 ppm = 2091.500 Hz				
Power Supply (Vdc)	Environment Temperature (°C)	Frequency Deviation Measured with Time Elapse		
		(MHz)	Delta (ppm)	Limit (ppm)
5.00	50	836.600027	-0.027	2.5
5.00	40	836.600019	-0.018	2.5
5.00	30	836.600013	-0.011	2.5
5.00	20	836.600004	0	2.5
5.00	10	836.600024	-0.024	2.5
5.00	0	836.600057	-0.063	2.5
5.00	-10	836.600042	-0.045	2.5
5.00	-20	836.600036	-0.038	2.5
5.00	-30	836.599980	0.029	2.5

Reference Frequency: Cellular Mid Channel 836.600004MHz @ 20°C Limit: to stay +/- 2.5 ppm = 2091.500 Hz				
Power Supply (Vdc)	Environment Temperature (°C)	Frequency Deviation Measured with Time Elapse		
		(MHz)	Delta (ppm)	Limit (ppm)
100%	20	836.600004	0	2.5
85%	20	836.599996	0.010	2.5
115%	20	836.600006	-0.002	2.5

PCS, GSM MODULATION – MID CHANNEL

Reference Frequency: PCS Mid Channel 1880.000048MHz @ 20°C Limit: within the authorized block or +/- 2.5 ppm = 4700.000 Hz				
Power Supply (Vdc)	Environment Temperature (°C)	Frequency Deviation Measured with Time Elapse		
		(MHz)	Delta (ppm)	Limit (ppm)
5.00	50	1880.000031	0.009	2.5
5.00	40	1880.000061	-0.007	2.5
5.00	30	1880.000087	-0.021	2.5
5.00	20	1880.000048	0	2.5
5.00	10	1880.000097	-0.026	2.5
5.00	0	1880.000119	-0.038	2.5
5.00	-10	1880.000084	-0.019	2.5
5.00	-20	1880.000067	-0.010	2.5
5.00	-30	1880.000016	0.017	2.5

Reference Frequency: PCS Mid Channel 1880.000048MHz @ 20°C Limit: within the authorized block or +/- 2.5 ppm = 4700.000 Hz				
Power Supply (Vdc)	Environment Temperature (°C)	Frequency Deviation Measured with Time Elapse		
		(MHz)	Delta (ppm)	Limit (ppm)
100%	20	1880.000048	0	2.5
85%	20	1880.000026	0.012	2.5
115%	20	1880.000021	0.014	2.5