

FCC Part 22H&90S Test Report

Product Name : Wireless Module
Model No. : MC7354B
FCC ID : N7NMC7354B
IC : 2417C-MC7354B

Applicant : Sierra Wireless Inc.

Address : 13811 Wireless Way Richmond, British Columbia,
Canada, V6V 3A4.

Date of Receipt : Jun. 08, 2015
Test Date : Jun. 08, 2015~ Jul. 09, 2015
Issued Date : Jul. 13, 2015
Report No. : 1560266R-HP-US-P07V01
Report Version : V 3.0

The test results relate only to the samples tested.

The test results shown in the test report are traceable to the national/international standard through the calibration of the equipment and evaluated measurement uncertainty herein.

This report must not be used to claim product endorsement by any agency of the government.

The test report shall not be reproduced without the written approval of QuieTek Corporation.

Test Report Certification

Issued Date : Jul. 13, 2015

Report No. : 1560266R-HP-US-P07V01



Product Name : Wireless Module
Applicant : Sierra Wireless Inc.
Address : 13811 Wireless Way Richmond, British Columbia, Canada,
V6V 3A4.
Manufacturer : Sierra Wireless Inc.
Address : 13811 Wireless Way Richmond, British Columbia, Canada,
V6V 3A4.
Model No. : MC7354B
FCC ID : N7NMC7354B
IC : 2417C-MC7354B
EUT Voltage : DC 5V
Applicable Standard : FCC CFR Title 47 Part 2, TIA/EIA 603-D
FCC Part 22 Subpart H
FCC Part 90 Subpart S
Industry Canada RSS-132, Issue 3
Test Result : Complied
Performed Location : Suzhou EMC Laboratory
No.99 Hongye Rd., Suzhou Industrial Park, Suzhou, 215006,
Jiangsu, China
TEL: +86-512-6251-5088 / FAX: +86-512-6251-5098
FCC Registration Number: 800392; IC Lab Code: 4075B

Documented By : Elaine Wang
Reviewed By : Hayden
Approved By : Dean Cao

Laboratory Information

We, **QuietTek Corporation**, are an independent EMC and safety consultancy that was established the whole facility in our laboratories. The test facility has been accredited/accepted(audited or listed) by the following related bodies in compliance with ISO 17025, EN 45001 and specified testing scope:

Taiwan R.O.C.	:	BSMI, NCC
USA	:	FCC
Japan	:	VCCI

The related certificate for our laboratories about the test site and management system can be downloaded from QuietTek Corporation's Web Site : <http://www.quietek.com/english/about/certificates.aspx?bval=5>
The address and introduction of QuietTek Corporation's laboratories can be founded in our Web site : http://www.quietek.com/index_en.aspx

If you have any comments, Please don't hesitate to contact us. Our contact information is as below:

HsinChu Testing Laboratory :

No.75-2, 3rd Lin, Wangye Keng, Yonghxing Tsuen, Qionglin Shiang, Hsinchu County 307, Taiwan, R.O.C.
TEL:+886-3-592-8858 / FAX:+886-3-592-8859 E-Mail : service@quietek.com

LinKou Testing Laboratory :

No.5-22, Ruishukeng, Linkou Dist., New Taipei City 24451, Taiwan, R.O.C.
TEL : 886-2-8601-3788 / FAX : 886-2-8601-3789 E-Mail : service@quietek.com

Suzhou Testing Laboratory :

No.99 Hongye Rd., Suzhou Industrial Park, Suzhou, 215006, Jiangsu, China
TEL : +86-512-6251-5088 / FAX : 86-512-6251-5098 E-Mail : service@quietek.com

TABLE OF CONTENTS

Description	Page
1. General Information.....	7
1.1. EUT Description	7
1.2. Mode of Operation.....	8
1.3. Tested System Details	9
1.4. Configuration of Tested System.....	10
1.5. EUT Exercise Software.....	11
2. Technical Test	12
2.1. Summary of Test Result.....	12
2.2. Test Environment.....	14
3. Maximum Output Power and Effective Isotropic Radiated Power Measurement.....	15
3.1. Test Equipment.....	15
3.2. Test Setup.....	16
3.3. Test Procedure	16
3.4. Uncertainty	17
3.5. Test Result.....	18
4. Modulation Characteristic	28
4.1. Test Equipment.....	28
4.2. Test Setup.....	28
4.3. Limit.....	28
4.4. Uncertainty	28
4.5. Test Result.....	28
5. Occupied Bandwidth.....	29
5.1. Test Equipment.....	29
5.2. Test Setup.....	29
5.3. Test Procedure	29
5.4. Uncertainty	29
5.5. Test Result.....	30
6. Conducted Band Edge	64
6.1. Test Equipment.....	64
6.2. Test Setup.....	64
6.3. Test Procedure	64
6.4. Uncertainty	64
6.5. Test Result.....	65
7. Spurious Emission	137
7.1. Test Equipment.....	137
7.2. Test Setup.....	138

7.3. Test Procedure 140
7.4. Uncertainty 140
7.5. Test Result..... 141
8. Frequency Stability Under Temperature & Voltage Variations..... 152
8.1. Test Equipment..... 152
8.2. Test Setup..... 152
8.3. Test Procedure 153
8.4. Uncertainty 153
8.5. Test Result..... 154

History of This Test Report

REPORT NO.	VERSION	DESCRIPTION	ISSUED DATE
1560266R-HP-US-P07V01	V1.0	Initial Issued Report	Jun. 25, 2015
1560266R-HP-US-P07V01	V2.0	(1) Add the test requirement of regulation Part 90S (2) Replaced the original low channel and high channel in Part 22H	Jul. 10, 2015
1560266R-HP-US-P07V01	V3.0	(3) Modify the Maximum Output Power of test channel	Jul. 13, 2015

1. General Information

1.1. EUT Description

Product Name	Wireless Module
Model No.	MC7354B
EUT Voltage	DC 5V
4G	
Support Band	LTE Band 26
Uplink	Band 26: 814~849MHz
Downlink	Band 26: 859~894MHz
Type of modulation	QPSK, 16QAM
Antenna Type	Dipole
Antenna Gain	Band 26: 1dBi

1.2. Mode of Operation

QuieTek has verified the construction and function in typical operation. All the test modes were carried out with the EUT in normal operation, which was shown in this test report and defined as:

Test Mode
Mode 1: LTE Band 26

Note:

1. Regards to the frequency band operation: the lowest, middle and highest frequency of channel were selected to perform the test, then shown on this report.
2. For the radiated emission test and conducted test, We have evaluated the each channel bandwidth of RB size and RB offset, show the worst result on this report.
3. Because of the band 26 occupies two bands which are 814-824MHz, 824-849 so we test the band 26 with regulation Part 90S&Part 22H.

1.3. Tested System Details

The types for all equipments, plus descriptions of all cables used in the tested system (including inserted cards) are:

Product	Manufacturer	Model No.	Serial No.	Power Cord
1 Radio Communication Tester	Anritsu	MT8820C	6201181503	N/A

1.4. Configuration of Tested System

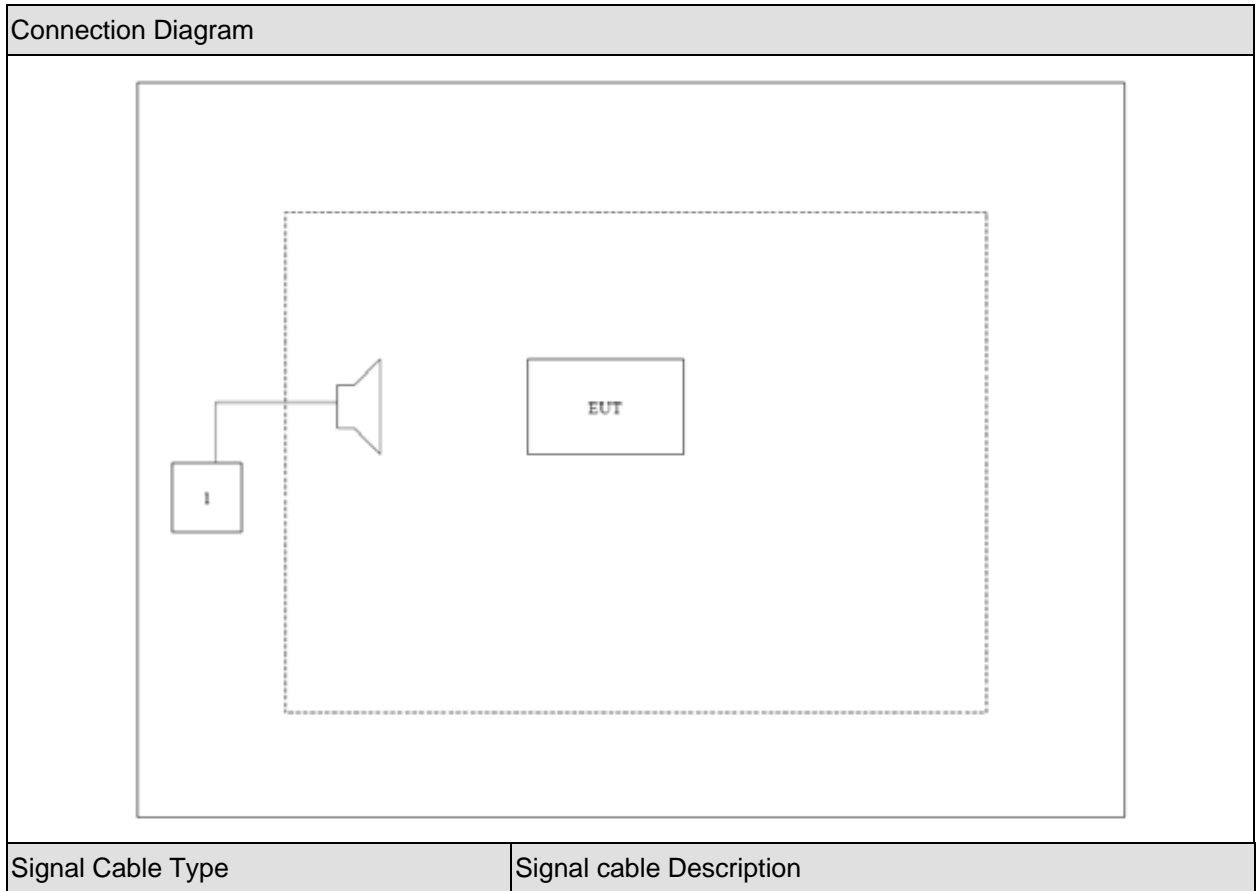

1.5. EUT Exercise Software

1	Setup the EUT and simulators as shown on above.
2	Turn on the power of all equipment.
3	EUT Communicate with MT8820C, then select channel to test.

2. Technical Test

2.1. Summary of Test Result

For LTE Band 26(Mid & High Channel)

(FCC Part 22 Subpart H, Industry Canada RSS-132, Issue 3, Industry Canada RSS-GEN, Issue 4)

Performed Item	FCC Rule	IC Rule	Limit	Result
Maximum Output Power	§2.1033 §2.1046 §22.913	§5.4	< 7 Watts	Pass
Equivalent Isotropic Radiated Power	§22.913	§5.4	< 7 Watts	Pass
Modulation characteristics	§2.1047	§5.2	N/A	Pass
Occupied Bandwidth	§2.1049	RSS-GEN §4.2	N/A	Pass
Conducted Band Edge Emissions	§22.917	§5.5	< -13dBm	Pass
Field Strength of Spurious Radiation	§2.1053 §§22.917	§5.5	< -13dBm	Pass
Frequency Stability Under Temperature & Voltage Variations	§2.1055 §22.335	§5.3	< 2.5 ppm	Pass

For LTE Band 26 (Low channel)
(FCC Part 90 Subpart S & Part 2)

Performed Item	FCC Rule	Limit	Result
Maximum Output Power	§2.1033	< 30 Watts	Pass
	§2.1046		
	§90.635		
Equivalent Isotropic Radiated Power	§90.635	< 30 Watts	Pass
Modulation characteristics	§2.1047	N/A	Pass
Occupied Bandwidth	§2.1049	N/A	Pass
Conducted Band Edge Emissions	§90.691	< - 20dBm&-13dBm	Pass
Field Strength of Spurious Radiation	§2.1053	< -13dBm	Pass
	§90.691		
Frequency Stability Under Temperature & Voltage Variations	§2.1055 §90.231	< 2.5 ppm	Pass

2.2. Test Environment

Items	Required (IEC 68-1)	Actual
Temperature (°C)	15-35	23
Humidity (%RH)	25-75	52
Barometric pressure (mbar)	860-1060	950-1000

3. Maximum Output Power and Effective Isotropic Radiated Power Measurement

3.1. Test Equipment

Peak Conducted Output Power / AC-6

Instrument	Manufacturer	Type No.	Serial No	Cali. Due Date
PSA Series Spectrum Analyzer	Agilent	E4440A	MY49420184	2016/03/10
Radio Communication Tester	R&S	CMU 200	117088	2016/03/10
Dual Directional Coupler	Agilent	778D	20160	2016/03/10
10dB Coaxial Coupler	Agilent	87300C	MY44300299	2016/03/10
Temperature/Humidity Meter	Zhicheng	ZC1-2	AC6-TH	2016/01/07

Peak Radiated Output Power / AC-5

Instrument	Manufacturer	Type No.	Serial No	Cali. Due Date
Radio Communication Tester	R&S	CMU 200	117088	2016/03/10
Preamplifier	Miteq	NSP1800-25	1364185	2016/05/03
Preamplifier	Quietek	AP-040G	CHM-0906001	2016/05/03
Bilog Antenna	Teseq GmbH	CBL6112D	27612	2016/10/15
DRG Horn	ETS-Lindgren	3117	00123988	2016/01/07
Broad-Band Horn Antenna	Schwarzbeck	BBHA9120D	737	2016/03/01
Coaxial Cable	Huber+Suhner	SUCOFLEX 106	AC5-C1	2016/03/01
Coaxial Cable	Huber+Suhner	SUCOFLEX 106	AC5-C2	2016/03/01
Coaxial Cable	Huber+Suhner	SUCOFLEX 102	AC5-C3	2016/03/10
EMI Receiver	Agilent	N9038A	MY51210196	2015/08/07
Temperature/Humidity Meter	Zhichen	ZC1-2	AC5-TH	2016/01/07

3.2. Test Setup

Conducted Power Measurement:

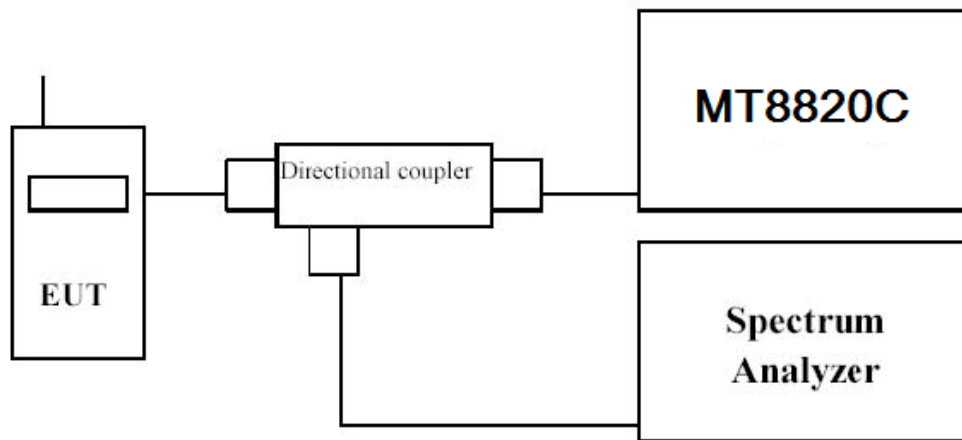

Radiated Power Measurement:

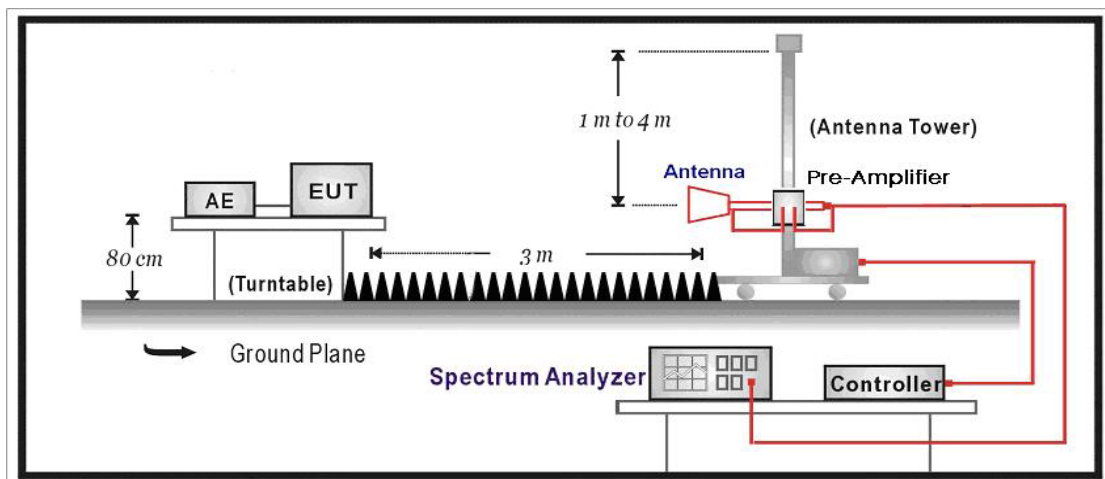

3.3. Test Procedure

For Conducted Power Measurement:

- a) The RF output of the transmitter was connected to base station simulator.
- b) The RF output of EUT was connected to the spectrum analyzer by RF cable and attenuator. The path loss was compensated to the results for each measurement..
- c) Set EUT at maximum average power by base station simulator.
- d) Measure lowest, middle, and highest channels for each bandwidth and different modulation.

For Effective Isotropic Radiated Power Measurement:

- e) The EUT was placed on a turntable with 1.5 meter height in a fully anechoic chamber.
- f) The EUT was set at 3 meters from the receiving antenna, which was mounted on the antenna tower
- g) LTE operating modes: Set RBW= 100 KHz, VBW= 300 KHz, RMS detector over frame, and use
- h) channel power option with bandwidth=5MHz, per section 4.0 of KDB 971168 D01.
- i) The table was rotated 360 degrees to determine the position of the highest radiated power.
- j) The height of the receiving antenna is adjusted to look for the maximum EIRP.
- k) Taking the record of maximum EIRP.
- l) A dipole antenna was substituted in place of the EUT and was driven by a signal generator.
- m) The conducted power at the terminal of the dipole antenna is measured.
- n) Repeat step 3 to step 5 to get the maximum EIRP of the substitution antenna.
- o) $EIRP = P_s + E_t - E_s + G_s = P_s + R_t - R_s + G_s$.
- p) P_s (dBm) : Input power to substitution antenna
- q) G_s (dBi or dBd) : Substitution antenna Gain.
- r) $E_t = R_t + AF$
- s) $E_s = R_s + AF$
- t) AF (dB/m) : Receive antenna factor
- u) R_t : The highest received signal in spectrum analyzer for EUT.
- v) R_s : The highest received signal in spectrum analyzer for substitution antenna.

3.4. Uncertainty

The measurement uncertainty is defined as for Conducted Power Measurement ± 1.2 dB, for Radiated Power Measurement ± 3.2 dB

3.5. Test Result

Product	Wireless Module		
Test Item	Maximum Output Power		
Date of Test	2015/07/09	Test Site	TR-8

LTE Band 26 For Part 22H

BW [MHz]	RB Size	RB Offset	Mod	Maximum Average Power [dBm]		
				Low Ch. / Freq.	Mid Ch. / Freq.	High Ch. / Freq.
Channel				26865	26915	26965
Frequency				831.5	836.5	841.5
15	1	0	QPSK	23.13	23.03	22.97
15	1	37		23.05	23.01	22.96
15	1	74		23.12	22.97	22.41
15	36	0		21.87	21.81	21.80
15	36	18		21.81	21.84	21.67
15	36	37		21.80	21.77	21.65
15	75	0		21.79	21.74	21.72
15	1	0	16-QAM	22.33	22.29	22.20
15	1	37		22.30	22.27	22.19
15	1	74		22.20	22.15	22.11
15	36	0		20.88	20.78	20.75
15	36	18		20.93	20.89	20.83
15	36	37		20.94	20.87	20.81
15	75	0		20.83	20.81	20.77
Channel				26840	26915	26990
Frequency				829.0	836.5	844
10	1	0	QPSK	23.15	23.09	23.07
10	1	24		23.03	23.00	22.99
10	1	49		23.01	22.99	22.95
10	25	0		21.87	21.80	22.02
10	25	12		21.85	21.71	22.00
10	25	24		21.89	21.81	21.91
10	50	0		21.79	21.70	21.86
10	1	0	16-QAM	22.18	22.16	22.13
10	1	24		22.16	22.10	22.07

10	1	49		22.11	22.08	21.92
10	25	0		20.86	20.79	20.68
10	25	12		20.85	20.83	20.79
10	25	24		20.82	20.77	20.75
10	50	0		20.81	20.73	20.71
Channel				26815	26915	27015
Frequency				826.5	836.5	846.5
5	1	0	QPSK	23.06	23.04	22.83
5	1	12		23.06	22.95	22.82
5	1	24		23.03	22.89	21.83
5	12	0		21.97	21.94	21.83
5	12	6		21.96	21.87	21.77
5	12	11		21.95	21.91	21.90
5	25	0		21.89	21.77	21.75
5	1	0	16-QAM	22.08	22.05	22.02
5	1	12		22.05	22.01	21.98
5	1	24		22.06	22.03	21.99
5	12	0		20.95	20.93	21.91
5	12	6		20.98	20.95	20.92
5	12	11		20.94	20.92	20.89
5	25	0		20.91	20.89	20.85
Channel				26805	26915	27025
Frequency				825.5	836.5	847.5
3	1	0	QPSK	23.06	23.04	22.95
3	1	7		23.05	23.03	22.94
3	1	14		22.97	22.97	22.93
3	8	0		22.57	22.43	22.37
3	8	4		22.49	22.35	22.30
3	8	7		22.37	22.18	22.12
3	15	0		22.05	21.98	21.86
3	1	0	16-QAM	22.11	22.08	21.96
3	1	7		22.08	22.06	21.92
3	1	14		22.07	22.03	21.89
3	8	0		21.49	21.45	21.35
3	8	4		21.44	21.41	21.33
3	8	7		21.30	21.28	20.12
3	15	0		21.02	21.01	21.89

Channel				26797	26915	27033
Frequency				824.7	836.5	848.3
1.4	1	0	QPSK	23.12	23.06	22.58
1.4	1	2		23.08	23.01	22.26
1.4	1	5		23.06	23.02	21.74
1.4	3	0		23.01	23.00	22.34
1.4	3	1		22.99	22.95	22.21
1.4	3	2		22.96	22.92	22.08
1.4	6	0		22.09	22.03	21.98
1.4	1	0	16-QAM	22.11	22.05	21.96
1.4	1	2		22.05	22.03	21.99
1.4	1	5		22.06	22.04	21.98
1.4	3	0		22.00	21.98	21.95
1.4	3	1		21.98	21.95	21.90
1.4	3	2		21.96	21.91	21.81
1.4	6	0		21.05	21.03	21.95

Note: All conducted measurements are based on a RMS detector.

LTE Band 26 For Part 90S

BW [MHz]	RB Size	RB Offset	Mod	Maximum Average Power [dBm]		
				Low Ch. / Freq.	Mid Ch. / Freq.	High Ch. / Freq.
Channel				26740		
Frequency				819.0		
10	1	0	QPSK	23.16		
10	1	24		23.05		
10	1	49		23.03		
10	25	0		21.85		
10	25	12		21.84		
10	25	24		21.87		
10	50	0		21.78		
10	1	0	16-QAM	22.21		
10	1	24		22.16		
10	1	49		22.13		
10	25	0		20.88		
10	25	12		20.84		
10	25	24		20.81		
10	50	0		20.80		
Channel				26715	26740	26765
Frequency				816.5	819	821.5
5	1	0	QPSK	23.07	23.05	22.81
5	1	12		23.05	22.93	22.83
5	1	24		23.01	22.88	21.84
5	12	0		21.98	21.93	21.82
5	12	6		21.96	21.86	21.75
5	12	11		21.94	21.93	21.91
5	25	0		21.87	21.75	21.72
5	1	0	16-QAM	22.07	22.05	22.01
5	1	12		22.04	22.02	21.95
5	1	24		22.05	22.01	21.98
5	12	0		20.98	20.95	21.90
5	12	6		20.97	20.93	20.89
5	12	11		20.93	20.91	20.85
5	25	0		20.92	20.88	20.83
Channel				26705	26740	26775

Frequency				815.5	819	822.5
3	1	0	QPSK	23.11	23.08	22.05
3	1	7		23.08	23.05	22.93
3	1	14		22.99	22.98	22.95
3	8	0		22.61	22.44	22.40
3	8	4		22.51	22.33	22.29
3	8	7		22.33	22.21	22.20
3	15	0		22.04	21.95	21.90
3	1	0	16-QAM	22.14	22.09	21.98
3	1	7		22.05	22.03	21.95
3	1	14		22.10	22.07	21.95
3	8	0		21.48	21.44	21.31
3	8	4		21.43	21.41	21.38
3	8	7		21.32	21.25	20.10
3	15	0		21.05	21.02	21.92
Channel				26697	26740	26783
Frequency				814.7	819	823.3
1.4	1	0	QPSK	23.15	23.03	22.55
1.4	1	2		23.07	23.02	22.33
1.4	1	5		23.05	23.03	21.75
1.4	3	0		23.05	23.02	22.44
1.4	3	1		22.95	22.92	22.32
1.4	3	2		22.93	22.91	22.18
1.4	6	0		22.08	22.02	21.97
1.4	1	0	16-QAM	22.13	22.07	21.98
1.4	1	2		22.03	22.02	21.98
1.4	1	5		22.10	22.05	21.93
1.4	3	0		22.03	21.95	21.93
1.4	3	1		21.97	21.92	21.91
1.4	3	2		21.95	21.92	21.87
1.4	6	0		21.04	21.01	20.98

Note: All conducted measurements are based on a RMS detector.

Product	Wireless Module		
Test Item	Effective Isotropic Radiated Power		
Date of Test	2015/07/09	Test Site	AC-5

LTE Band 26 for Part 22H

LTE Band 26 Radiated Power EIRP							
LTE Band	Channel BW (MHz)	Modulation	RB Configuration		Freq. (MHz)	EIRP (dBm)	H/V
			RB Size	RB Offset			
26	15	QPSK	1	0	831.5	24.43	H
26	15	QPSK	1	0	836.5	24.22	H
26	15	QPSK	1	0	841.5	24.02	H
26	15	QPSK	1	0	831.5	22.38	V
26	15	QPSK	1	0	836.5	22.15	V
26	15	QPSK	1	0	841.5	22.01	V
26	15	16QAM	1	0	831.5	23.34	H
26	15	16QAM	1	0	836.5	23.21	H
26	15	16QAM	1	0	841.5	23.08	H
26	15	16QAM	1	0	831.5	21.19	V
26	15	16QAM	1	0	836.5	21.10	V
26	15	16QAM	1	0	841.5	21.04	V
26	10	QPSK	1	0	829.0	24.13	H
26	10	QPSK	1	0	836.5	24.11	H
26	10	QPSK	1	0	844.0	24.00	H
26	10	QPSK	1	0	829.0	22.10	V
26	10	QPSK	1	0	836.5	21.98	V
26	10	QPSK	1	0	844.0	21.93	V
26	10	16QAM	1	0	829.0	23.20	H
26	10	16QAM	1	0	836.5	23.15	H
26	10	16QAM	1	0	844.0	23.04	H
26	10	16QAM	1	0	829.0	22.11	V

26	10	16QAM	1	0	836.5	22.02	V
26	10	16QAM	1	0	844.0	21.94	V
26	5	QPSK	1	0	826.5	24.32	H
26	5	QPSK	1	0	836.5	24.23	H
26	5	QPSK	1	0	846.5	24.14	H
26	5	QPSK	1	0	826.5	22.22	V
26	5	QPSK	1	0	836.5	22.17	V
26	5	QPSK	1	0	846.5	22.04	V
26	5	16QAM	1	0	826.5	23.13	H
26	5	16QAM	1	0	836.5	23.02	H
26	5	16QAM	1	0	846.5	22.98	H
26	5	16QAM	1	0	826.5	21.04	V
26	5	16QAM	1	0	836.5	21.03	V
26	5	16QAM	1	0	846.5	20.85	V
26	3	QPSK	1	0	825.5	24.22	H
26	3	QPSK	1	0	831.5	24.13	H
26	3	QPSK	1	0	847.5	24.04	H
26	3	QPSK	1	0	825.5	22.13	V
26	3	QPSK	1	0	831.5	22.04	V
26	3	QPSK	1	0	847.5	21.97	V
26	3	16QAM	1	0	825.5	23.23	H
26	3	16QAM	1	0	831.5	23.15	H
26	3	16QAM	1	0	847.5	23.02	H
26	3	16QAM	1	0	825.5	21.11	V
26	3	16QAM	1	0	831.5	21.03	V
26	3	16QAM	1	0	847.5	20.98	V
26	1.4	QPSK	1	0	824.7	24.34	H
26	1.4	QPSK	1	0	836.5	24.22	H
26	1.4	QPSK	1	0	848.3	24.19	H
26	1.4	QPSK	1	0	824.7	22.22	V

26	1.4	QPSK	1	0	836.5	22.15	V
26	1.4	QPSK	1	0	848.3	22.08	V
26	1.4	16QAM	1	0	824.7	23.19	H
26	1.4	16QAM	1	0	836.5	23.17	H
26	1.4	16QAM	3	0	848.3	23.11	H
26	1.4	16QAM	1	0	824.7	21.03.	V
26	1.4	16QAM	1	0	836.5	20.98	V
26	1.4	16QAM	1	0	848.3	20.91	V

LTE Band 26 for Part 90S

LTE Band 26 Radiated Power EIRP							
LTE Band	Channel BW (MHz)	Modulation	RB Configuration		Freq. (MHz)	EIRP (dBm)	H/V
			RB Size	RB Offset			
26	10	QPSK	1	0	819.0	24.21	H
26	10	QPSK	1	0	819.0	22.09	V
26	10	16QAM	1	0	819.0	23.11	H
26	10	16QAM	1	0	819.0	21.05	V
26	5	QPSK	1	0	816.5	24.11	H
26	5	QPSK	1	0	819.0	24.06	H
26	5	QPSK	1	0	821.5	24.01	H
26	5	QPSK	1	0	816.5	22.15	V
26	5	QPSK	1	0	819.0	22.08	V
26	5	QPSK	1	0	821.5	22.01	V
26	5	16QAM	1	0	816.5	23.05	H
26	5	16QAM	1	0	819.0	23.01	H
26	5	16QAM	1	0	821.5	22.94	H
26	5	16QAM	1	0	816.5	21.08	V
26	5	16QAM	1	0	819.0	21.04	V
26	5	16QAM	1	0	821.5	20.95	V
26	3	QPSK	1	0	815.5	24.12	H
26	3	QPSK	1	0	819.0	24.05	H
26	3	QPSK	1	0	822.5	24.01	H
26	3	QPSK	1	0	815.5	22.18	V
26	3	QPSK	1	0	819.0	22.11	V
26	3	QPSK	1	0	822.5	21.95	V
26	3	16QAM	1	0	815.5	23.18	H
26	3	16QAM	1	0	819.0	23.15	H
26	3	16QAM	1	0	822.5	23.03	H

26	3	16QAM	1	0	815.5	21.12	V
26	3	16QAM	1	0	819.0	21.03	V
26	3	16QAM	1	0	822.5	20.95	V
26	1.4	QPSK	1	0	814.7	24.35	H
26	1.4	QPSK	1	0	819.0	24.24	H
26	1.4	QPSK	1	0	823.3	24.11	H
26	1.4	QPSK	1	0	814.7	22.21	V
26	1.4	QPSK	1	0	819.0	22.12	V
26	1.4	QPSK	1	0	823.3	22.01	V
26	1.4	16QAM	1	0	814.7	23.25	H
26	1.4	16QAM	1	0	819.0	23.18	H
26	1.4	16QAM	3	0	823.3	23.14	H
26	1.4	16QAM	1	0	814.7	21.03	V
26	1.4	16QAM	1	0	819.0	20.95	V
26	1.4	16QAM	1	0	823.3	20.90	V

4. Modulation Characteristic

4.1. Test Equipment

Modulation Characteristic / AC-6

Instrument	Manufacturer	Type No.	Serial No	Cal. Due Date
PSA Series Spectrum Analyzer	Agilent	E4440A	MY49420184	2016/03/10
Radio Communication Tester	Anritsu	MT8820C	6201181503	2016/03/10
Dual Directional Coupler	Agilent	778D	20160	2016/03/10
10dB Coaxial Coupler	Agilent	87300C	MY44300299	2016/03/10
Temperature/Humidity Meter	Zhicheng	ZC1-2	AC6-TH	2016/01/07

4.2. Test Setup

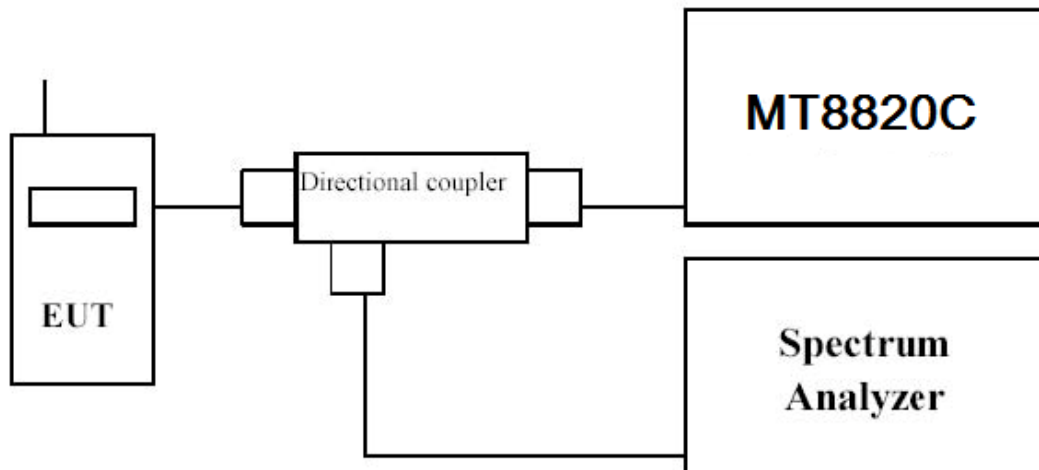

4.3. Limit

N/A

4.4. Uncertainty

The measurement uncertainty is defined as 0.1%

4.5. Test Result

The modulation of GSM/WCDMA was verified and confirmed compliance with requirement.

5. Occupied Bandwidth

5.1. Test Equipment

Occupied Bandwidth / AC-6

Instrument	Manufacturer	Type No.	Serial No	Cali. Due Date
PSA Series Spectrum Analyzer	Agilent	E4440A	MY49420184	2016/03/10
Radio Communication Tester	R&S	CMU 200	117088	2016/03/10
Dual Directional Coupler	Agilent	778D	20160	2016/03/10
10dB Coaxial Coupler	Agilent	87300C	MY44300299	2016/03/10
Temperature/Humidity Meter	Zhicheng	ZC1-2	AC6-TH	2016/01/07

5.2. Test Setup

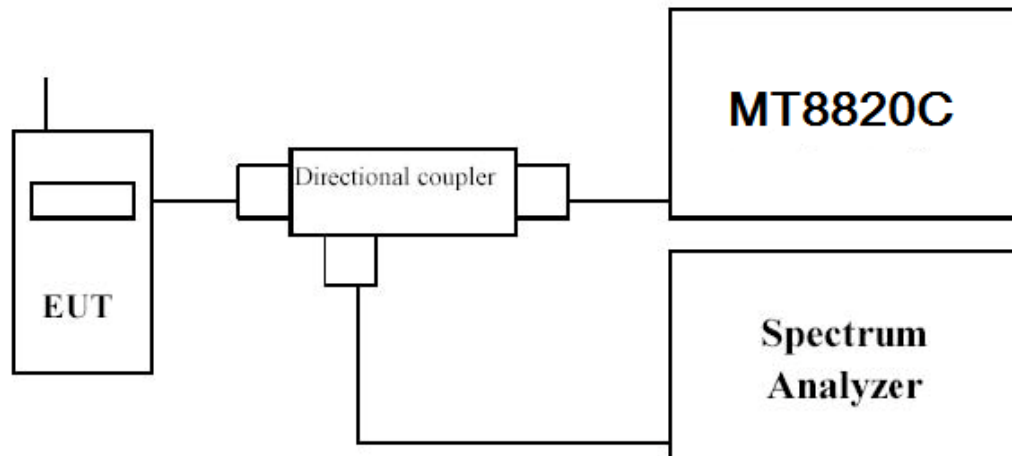

5.3. Test Procedure

1. The EUT was connected to Spectrum Analyzer and Base Station via power divider.
2. The RF output of EUT was connected to the spectrum analyzer by RF cable and attenuator. The path loss was compensated to the results for each measurement.
3. The 99% occupied bandwidth and 26 dB bandwidth of the middle channel for the highest RF powers were measured.

5.4. Uncertainty

The measurement uncertainty is defined as ± 10 Hz

5.5. Test Result

LTE Band 26 For Part 22H

Product	Wireless Module		
Test Item	Occupied Bandwidth		
Test Mode	Mode 1: LTE Band 26(15M/QPSK)		
Date of Test	2015/07/09	Test Site	AC6

Channel No.	Frequency (MHz)	99% Occupied Bandwidth (kHz)	-26dB Occupied Bandwidth (kHz)
26865	831.50	13480.90	14949.00
26915	836.50	13448.30	14843.00
26965	841.50	13449.50	14860.00

Figure Channel 26865 75RB0 (831.50MHz)

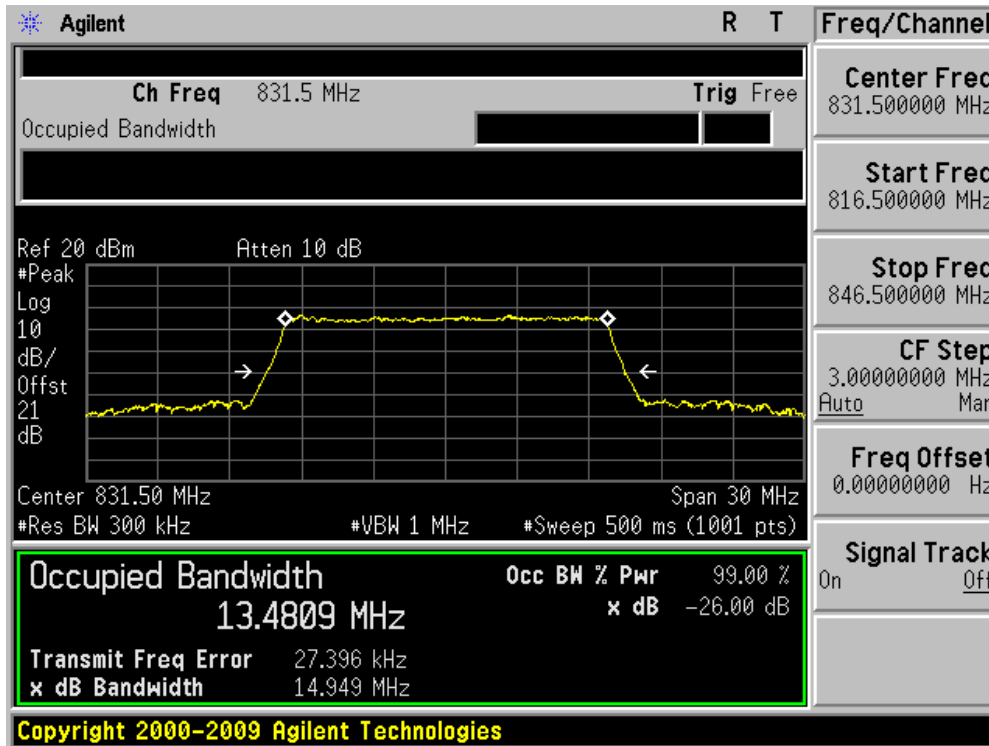

Figure Channel 26915 75RB0 (836.500MHz)

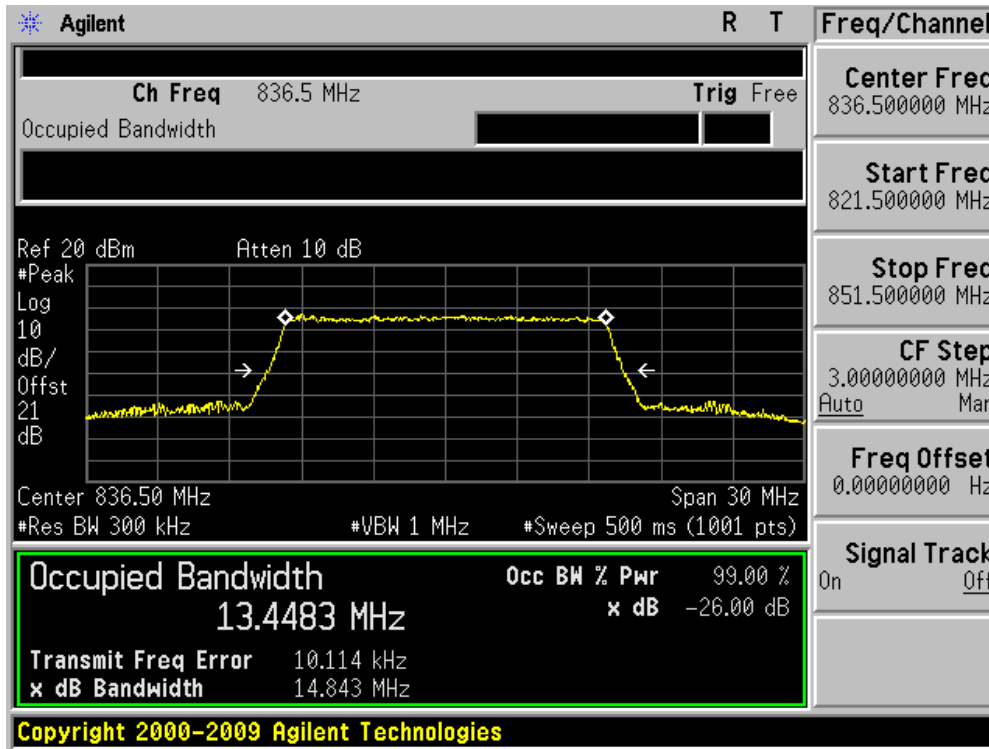
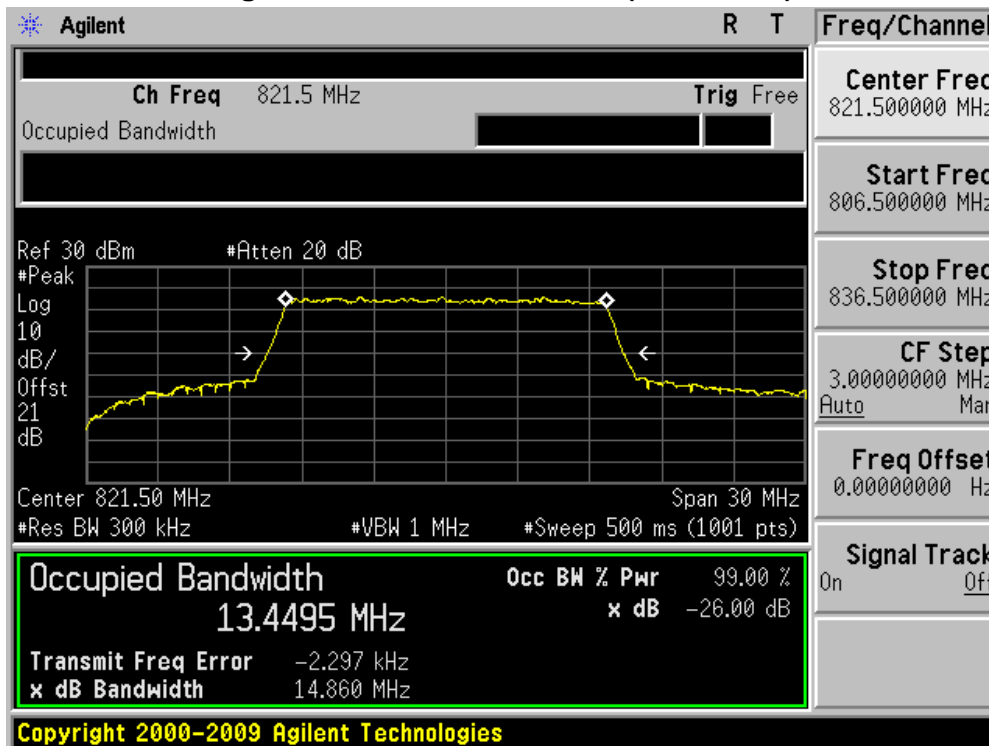

Figure Channel 26965 75RB0 (841.50MHz)



Product	Wireless Module		
Test Item	Occupied Bandwidth		
Test Mode	Mode 1: LTE Band 26 (15M/16QAM)		
Date of Test	2015/07/09	Test Site	AC6

Channel No.	Frequency (MHz)	99% Occupied Bandwidth (kHz)	-26dB Occupied Bandwidth (kHz)
26865	831.50	13464.80	14848.00
26915	836.50	13462.40	14866.00
26965	841.50	13427.50	14801.00

Figure Channel 26865 75RB0 (831.50MHz)

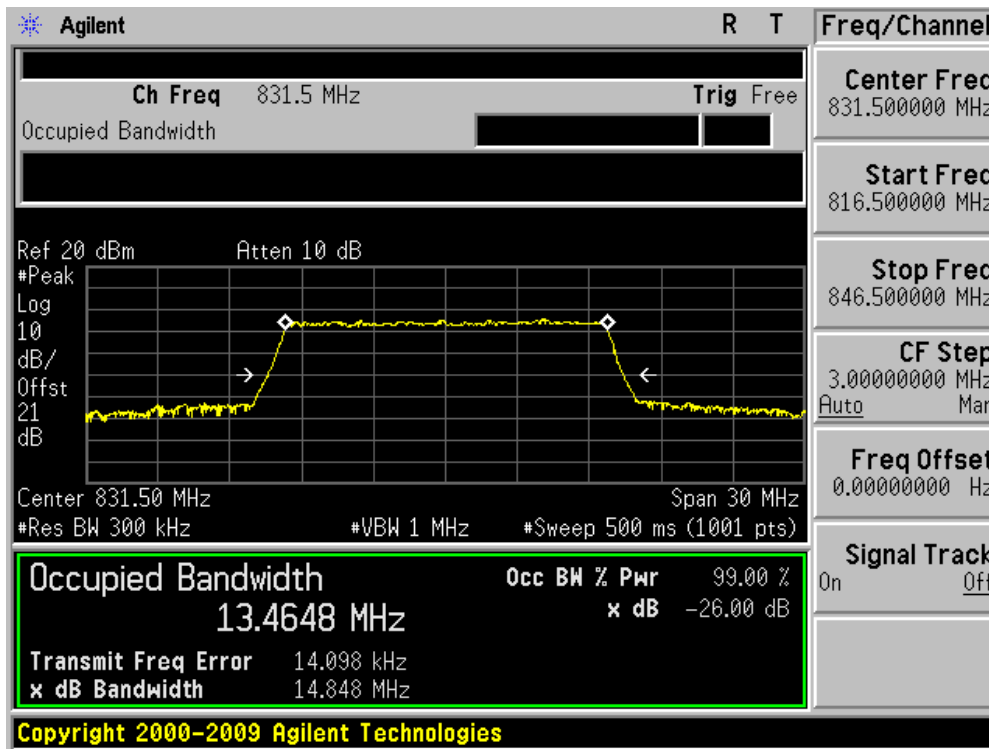

Figure Channel 26915 75RB0 (836.50MHz)

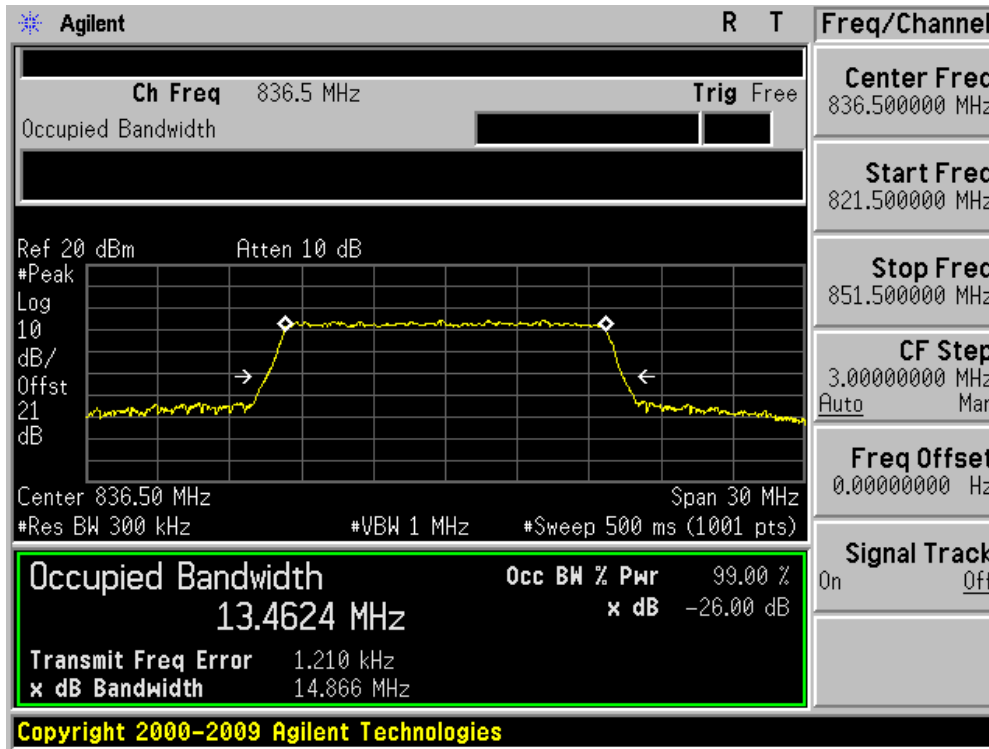
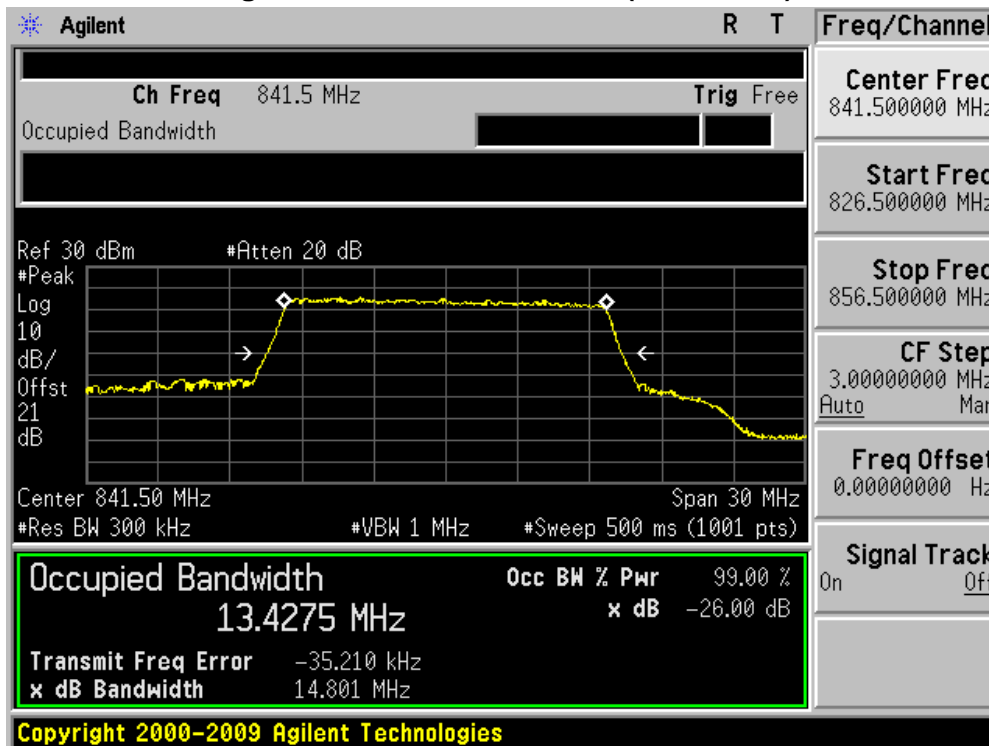

Figure Channel 26965 75RB0 (841.50MHz)



Product	Wireless Module		
Test Item	Occupied Bandwidth		
Test Mode	Mode 1: LTE Band 26(10M/QPSK)		
Date of Test	2015/07/09	Test Site	AC6

Channel No.	Frequency (MHz)	99% Occupied Bandwidth (kHz)	-26dB Occupied Bandwidth (kHz)
26840	829.00	9085.80	10167.00
26915	836.50	9064.20	10148.00
26990	844.00	9065.50	10182.00

Figure Channel 26840 50RB0 (829.00MHz)

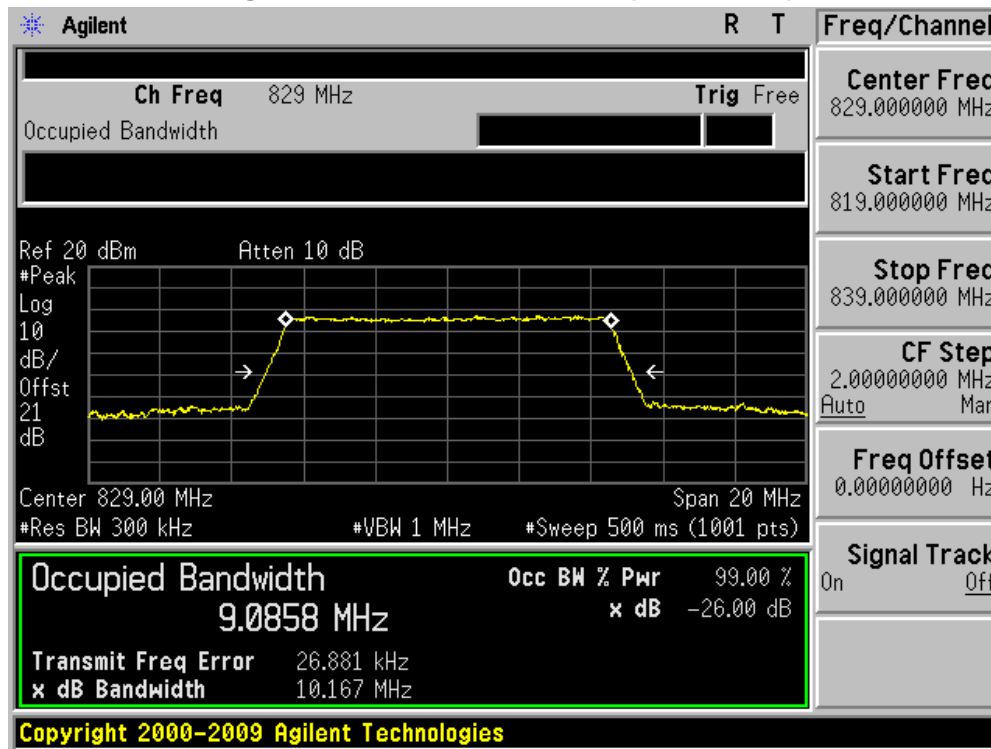

Figure Channel 26915 50RB0 (836.50MHz)

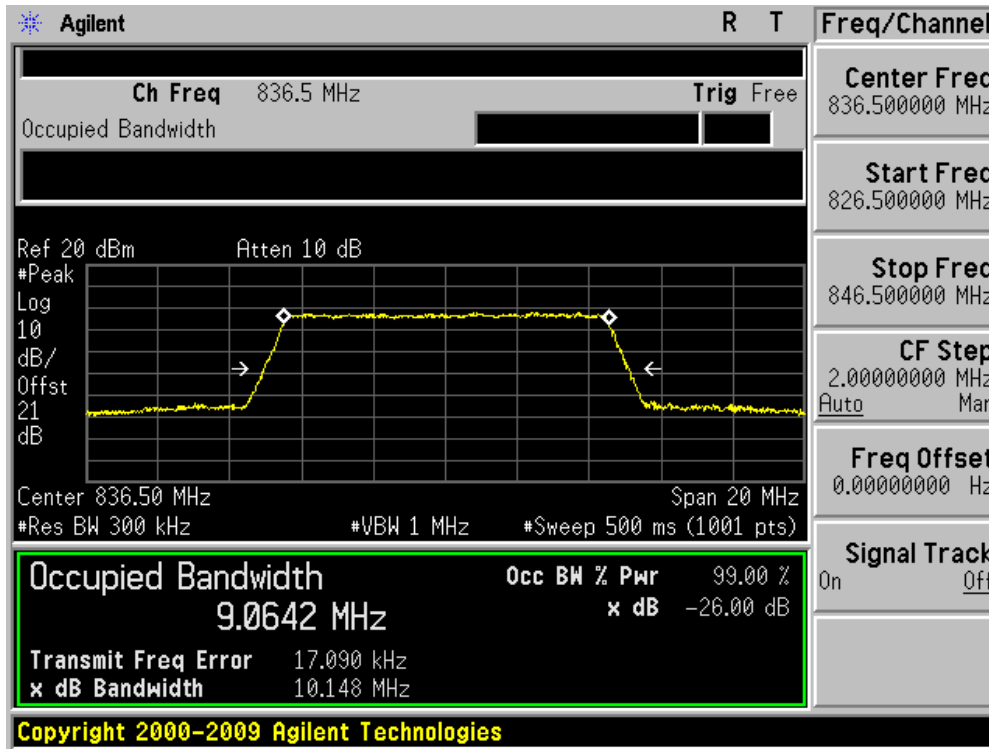
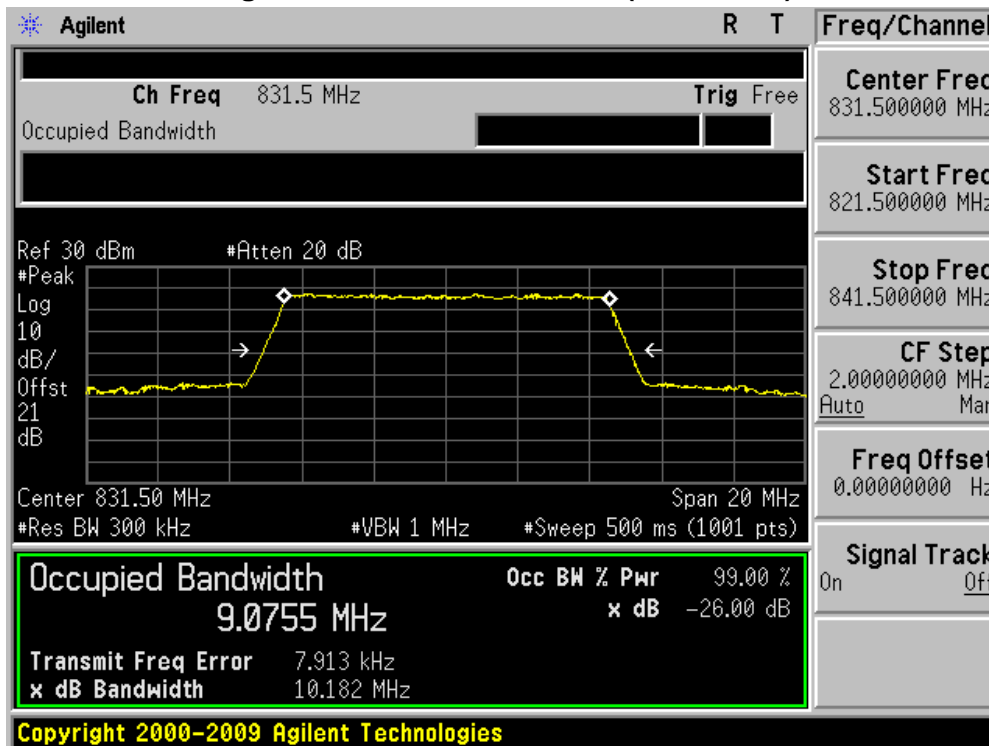

Figure Channel 26990 50RB0 (844.00MHz)



Product	Wireless Module		
Test Item	Occupied Bandwidth		
Test Mode	Mode 1: LTE Band 26 (10M/16QAM)		
Date of Test	2015/07/09	Test Site	AC6

Channel No.	Frequency (MHz)	99% Occupied Bandwidth (kHz)	-26dB Occupied Bandwidth (kHz)
26840	829.00	9036.50	10142.00
26915	836.50	9024.20	10150.00
26990	844.00	9030.80	10123.00

Figure Channel 26840 50RB0 (829.00MHz)

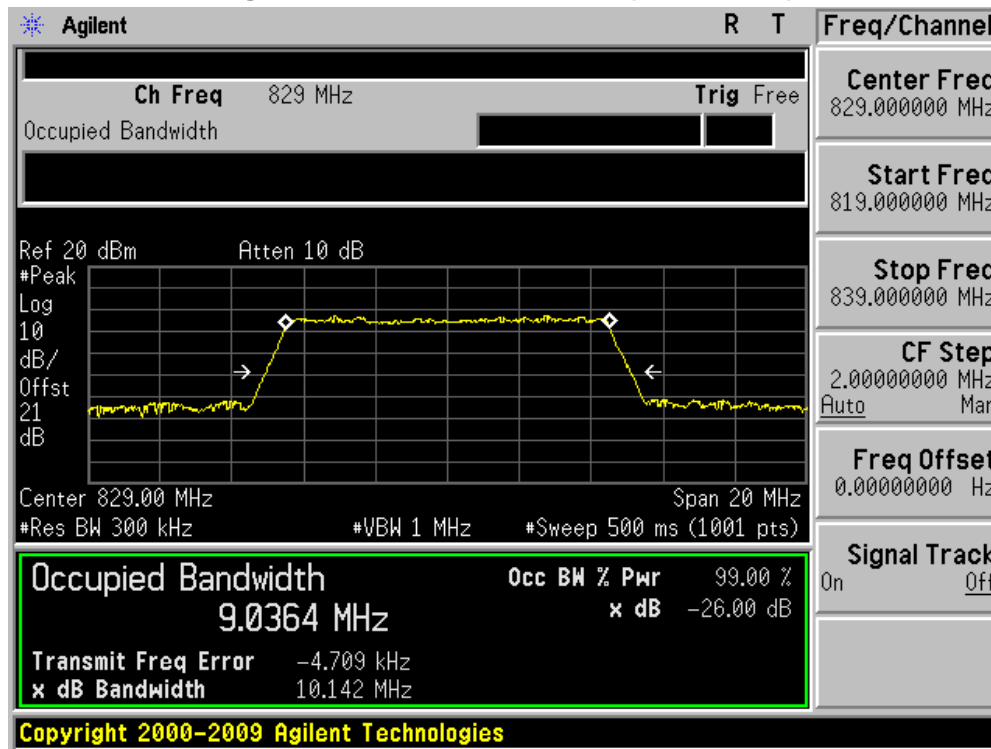

Figure Channel 26915 50RB0 (836.50MHz)

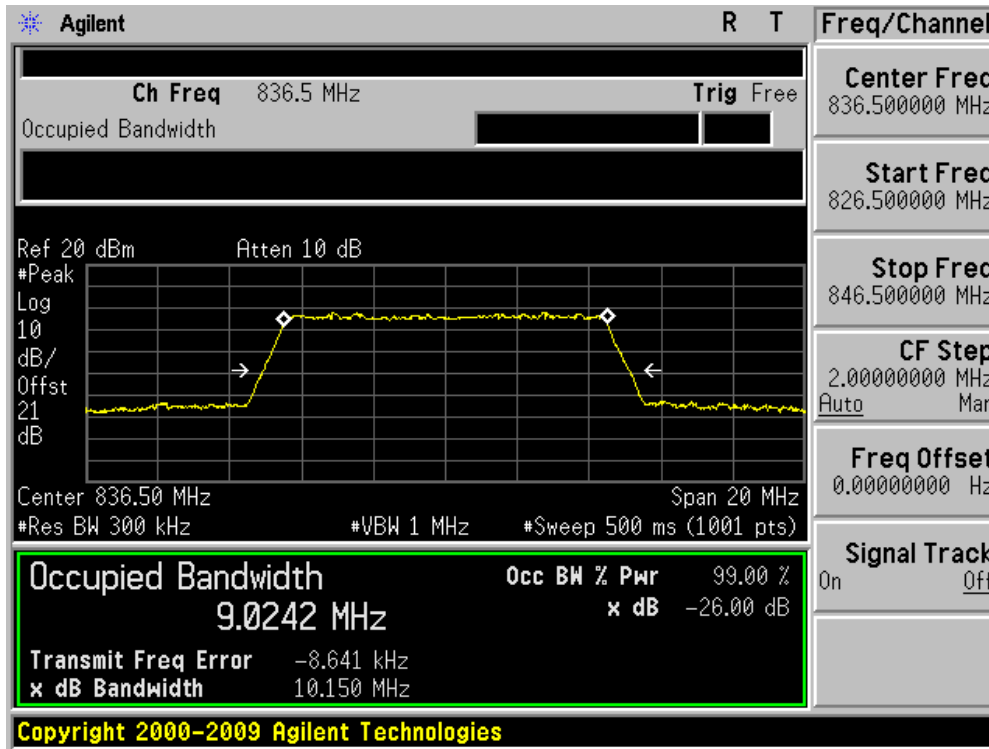
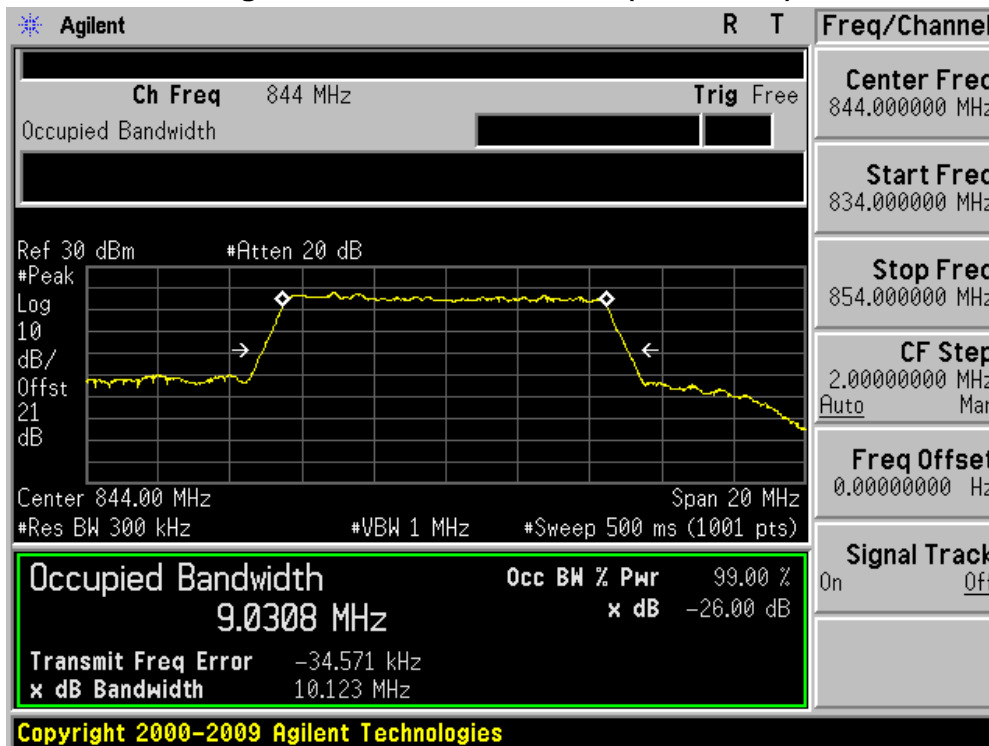

Figure Channel 26990 50RB0 (844.00MHz)



Product	Wireless Module		
Test Item	Occupied Bandwidth		
Test Mode	Mode 1: LTE Band 26(5M/QPSK)		
Date of Test	2015/07/09	Test Site	AC6

Channel No.	Frequency (MHz)	99% Occupied Bandwidth (kHz)	-26dB Occupied Bandwidth (kHz)
26815	826.50	4505.20	5064.00
26805	836.50	4501.50	5093.00
27015	846.50	4504.10	5045.00

Figure Channel 26815 25RB0 (826.50MHz)

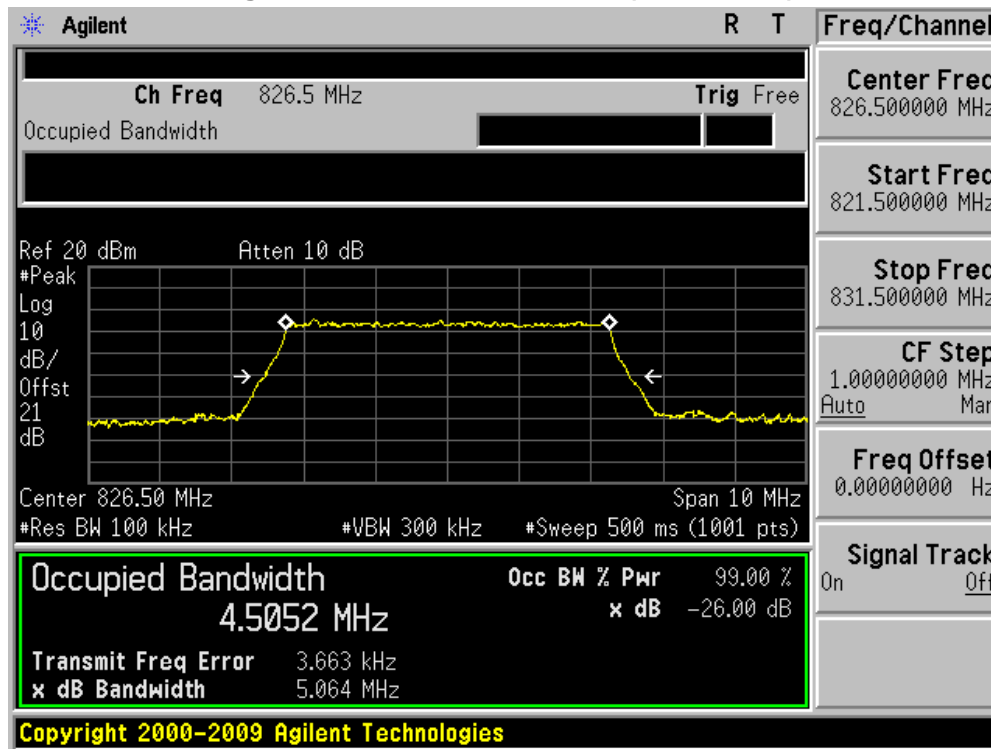

Figure Channel 26805 25RB0 (836.50MHz)

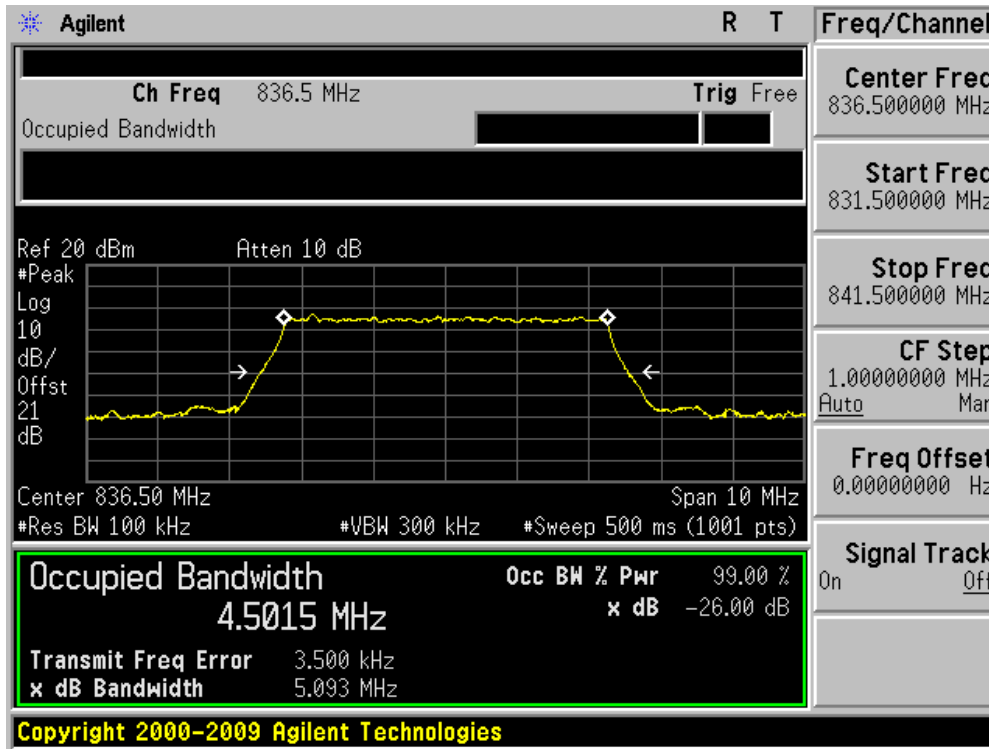
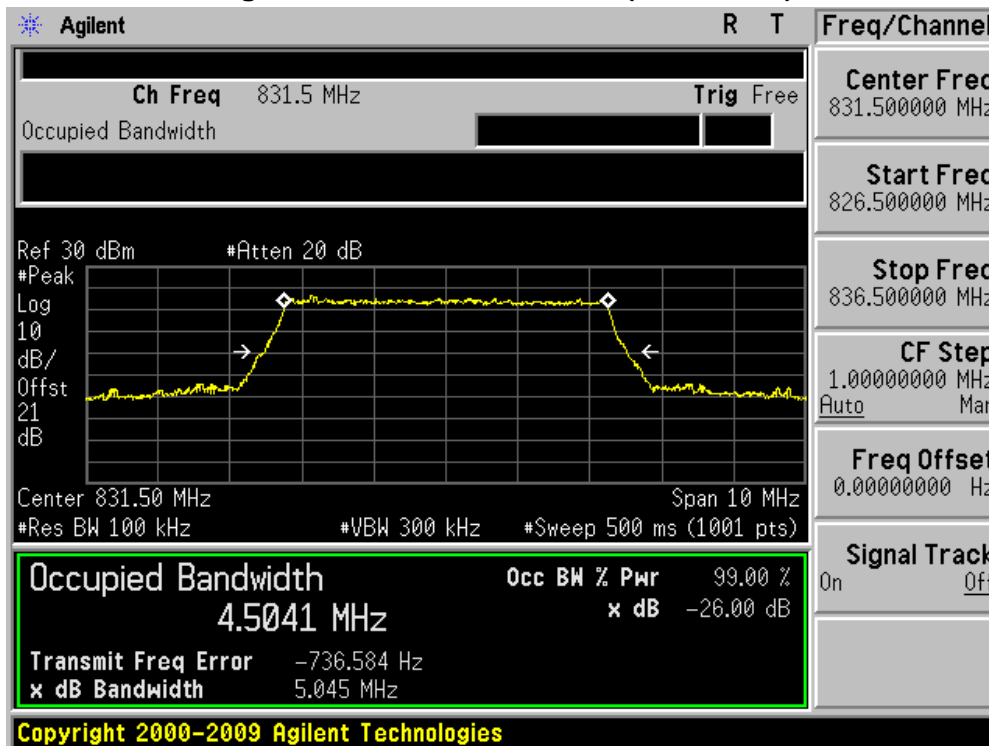

Figure Channel 20715 25RB0 (846.50MHz)



Product	Wireless Module		
Test Item	Occupied Bandwidth		
Test Mode	Mode 1: LTE Band 26 (5M/16QAM)		
Date of Test	2015/07/09	Test Site	AC6

Channel No.	Frequency (MHz)	99% Occupied Bandwidth (kHz)	-26dB Occupied Bandwidth (kHz)
26815	826.50	4483.50	5012.00
26805	836.50	4483.40	5012.00
27015	846.50	4485.10	5025.00

Figure Channel 26815 25RB0 (826.50MHz)

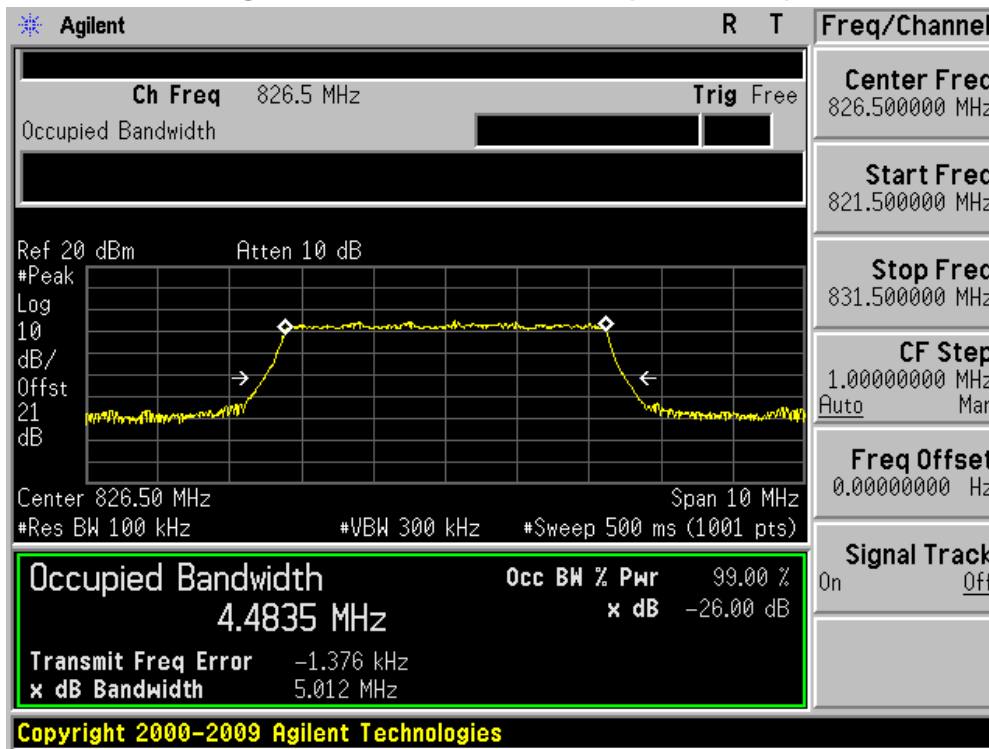

Figure Channel 26805 25RB0 (836.50MHz)

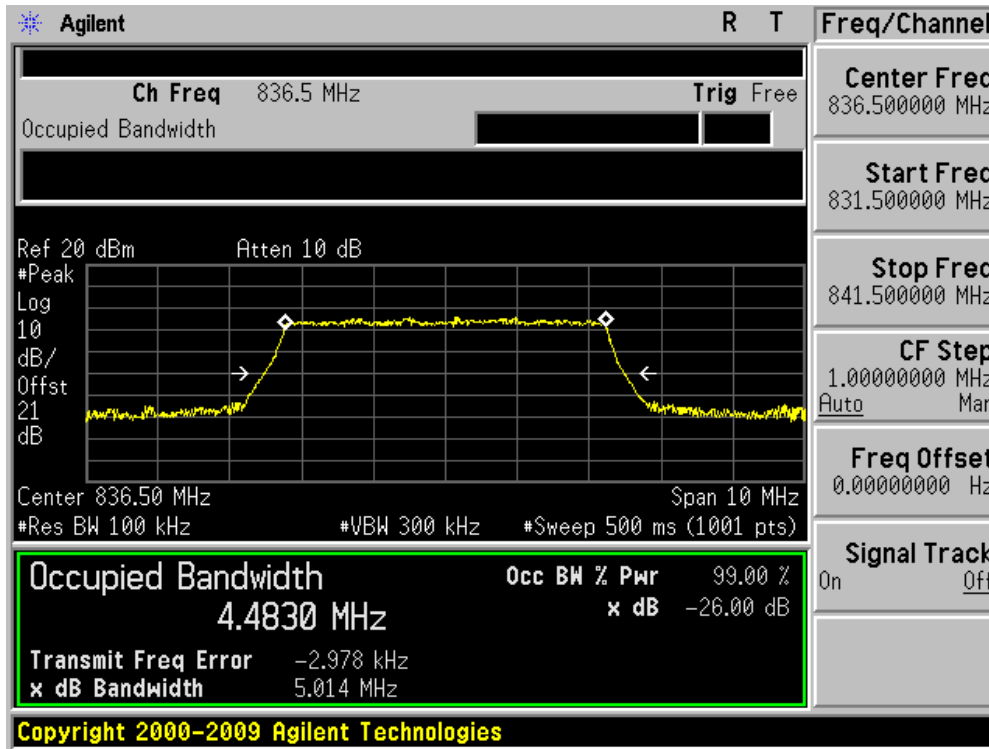
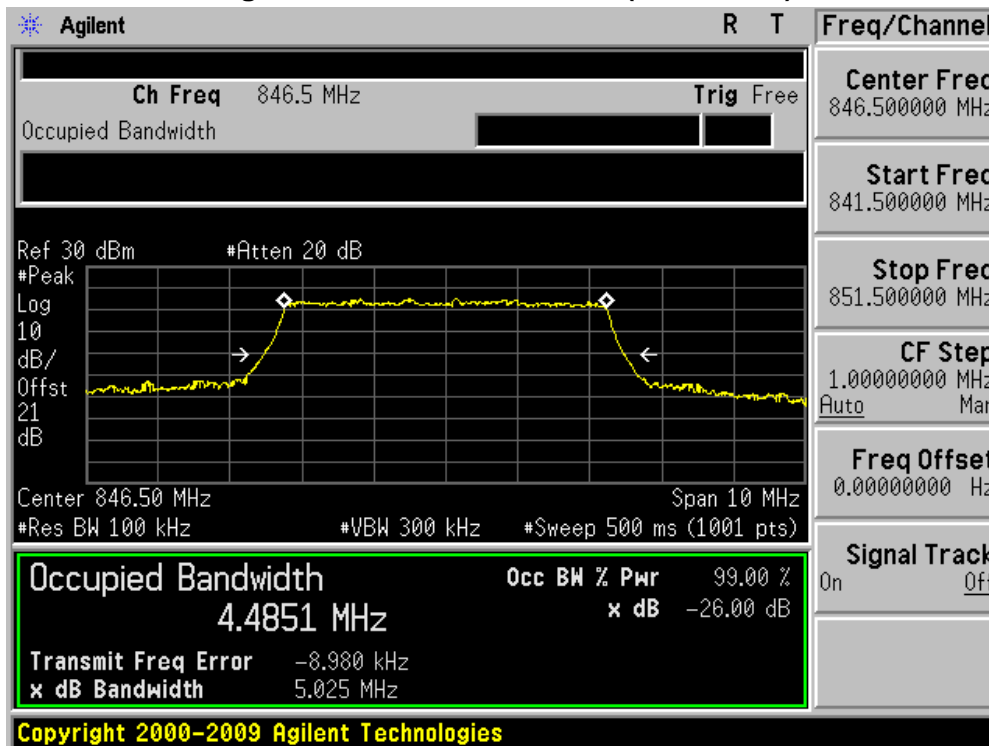

Figure Channel 27015 25RB0 (846.50MHz)



Product	Wireless Module		
Test Item	Occupied Bandwidth		
Test Mode	Mode 1: LTE Band 26(3M/QPSK)		
Date of Test	2015/07/09	Test Site	AC6

Channel No.	Frequency (MHz)	99% Occupied Bandwidth (kHz)	-26dB Occupied Bandwidth (kHz)
26805	825.50	2734.40	3115.00
26915	836.50	2733.40	3110.00
27025	846.50	2731.40	3145.00

Figure Channel 26805 15RB0 (825.50MHz)

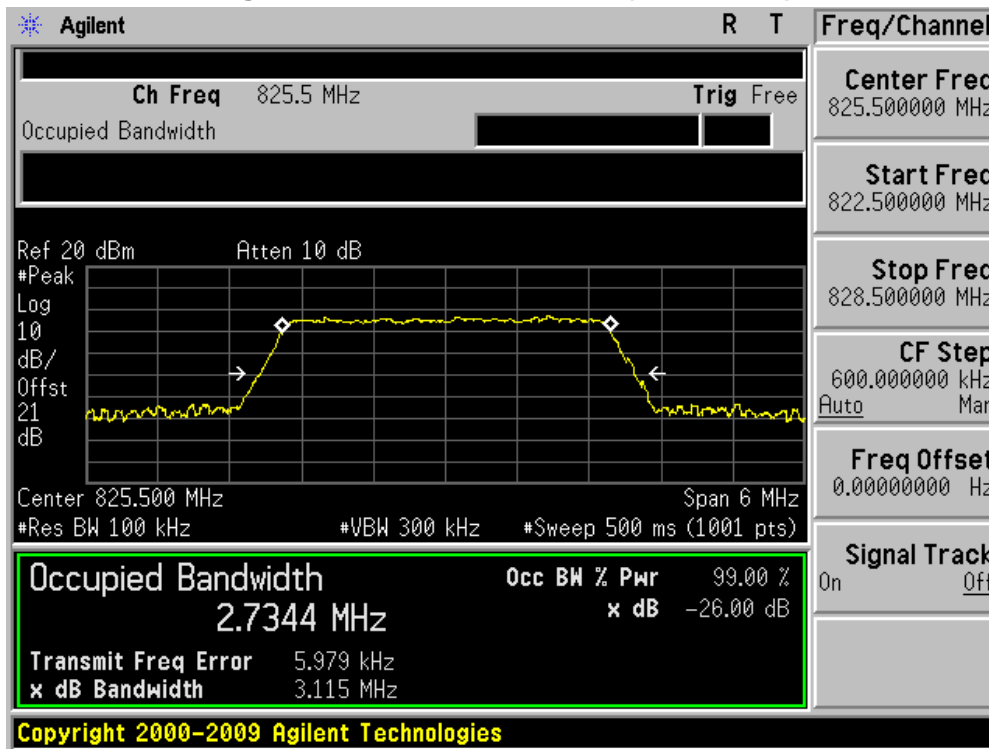

Figure Channel 26915 15RB0 (836.50MHz)

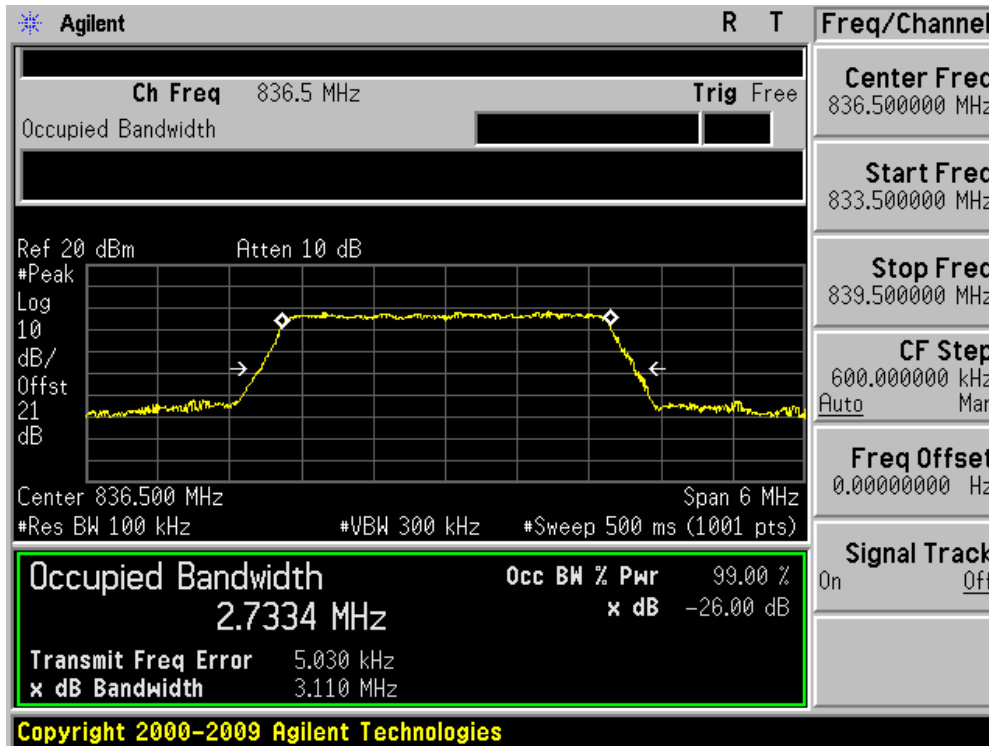
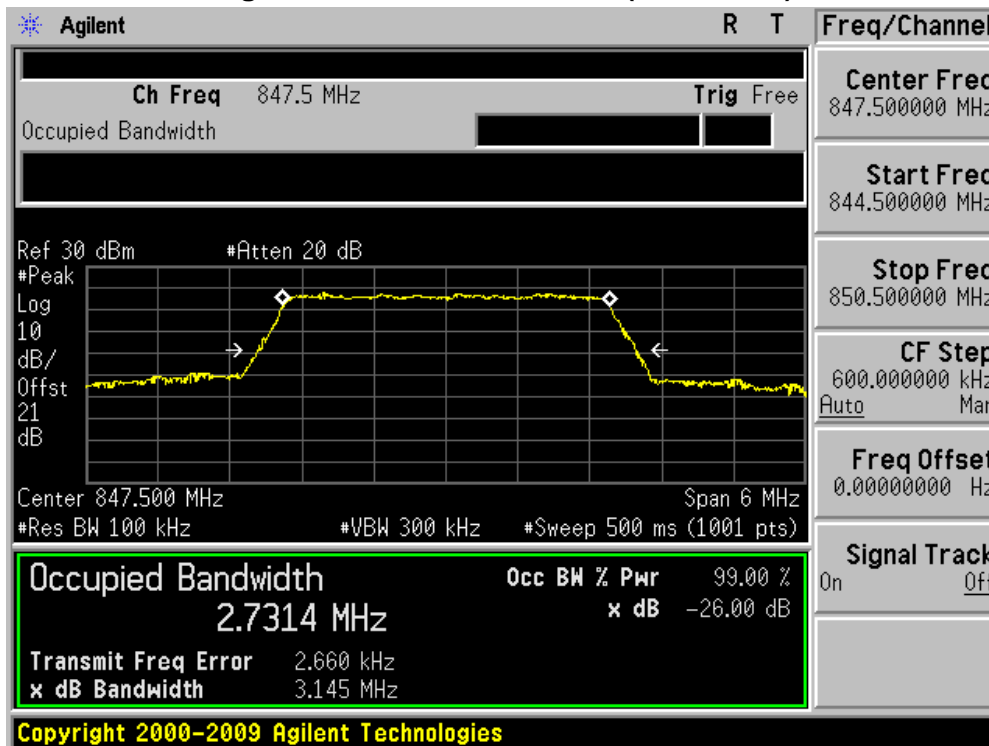

Figure Channel 27025 15RB0 (847.50MHz)



Product	Wireless Module		
Test Item	Occupied Bandwidth		
Test Mode	Mode 1: LTE Band 26 (3M/16QAM)		
Date of Test	2015/07/09	Test Site	AC6

Channel No.	Frequency (MHz)	99% Occupied Bandwidth (kHz)	-26dB Occupied Bandwidth (kHz)
26805	825.50	2741.80	3169.00
26915	836.50	2741.00	3166.00
27025	846.50	2735.20	3153.00

Figure Channel 26805 15RB0 (825.50MHz)

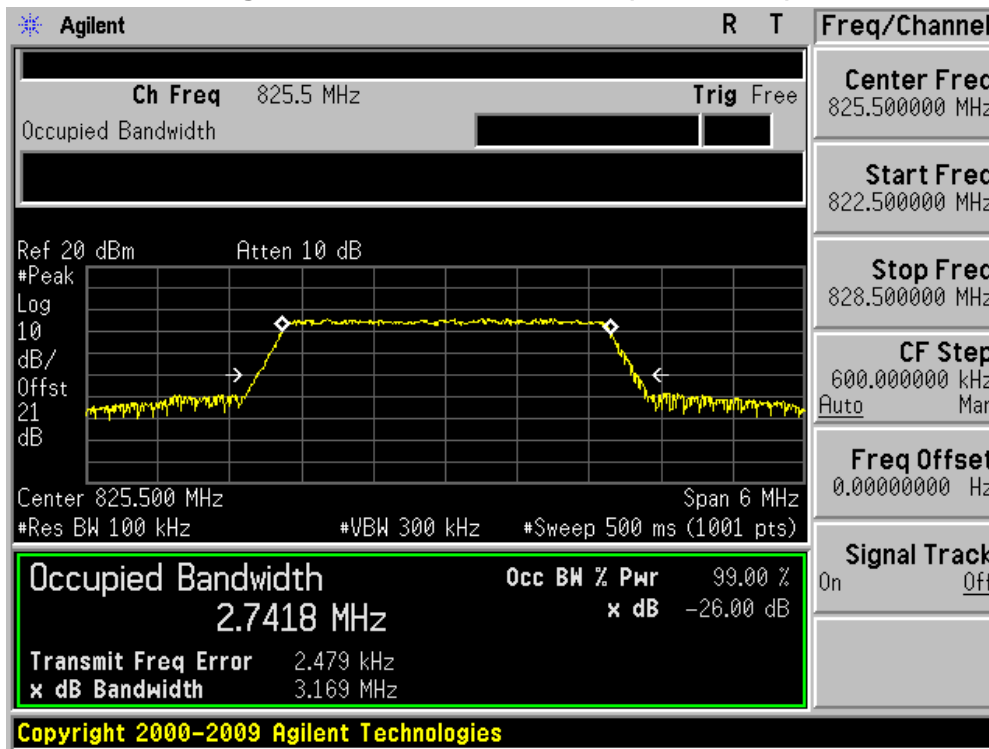

Figure Channel 26915 15RB0 (836.50MHz)

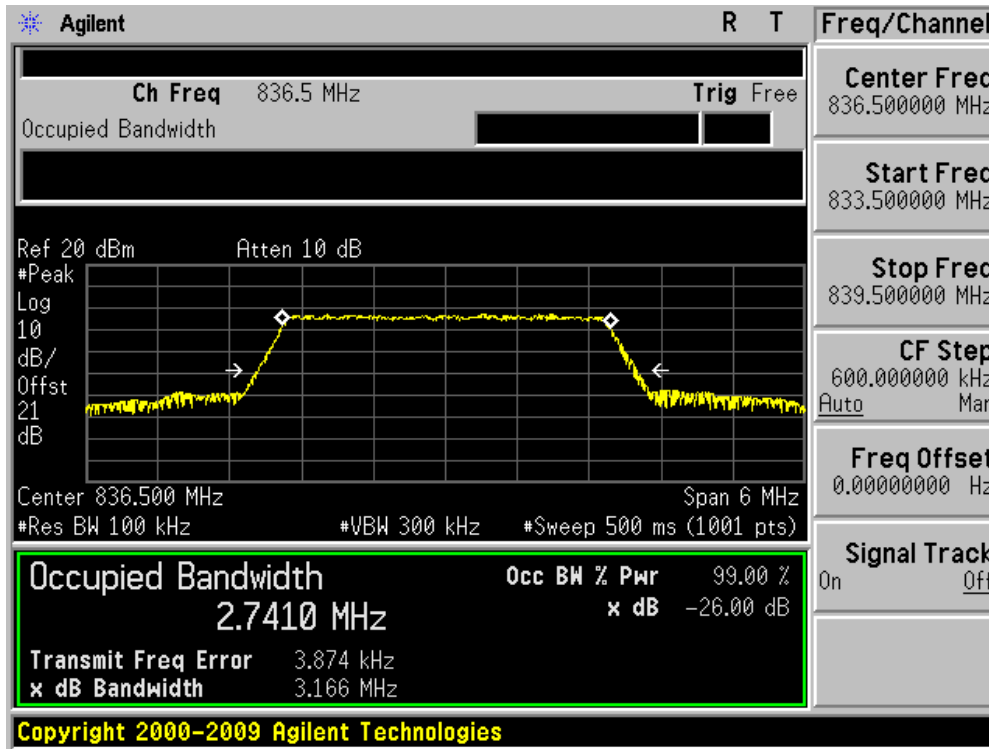
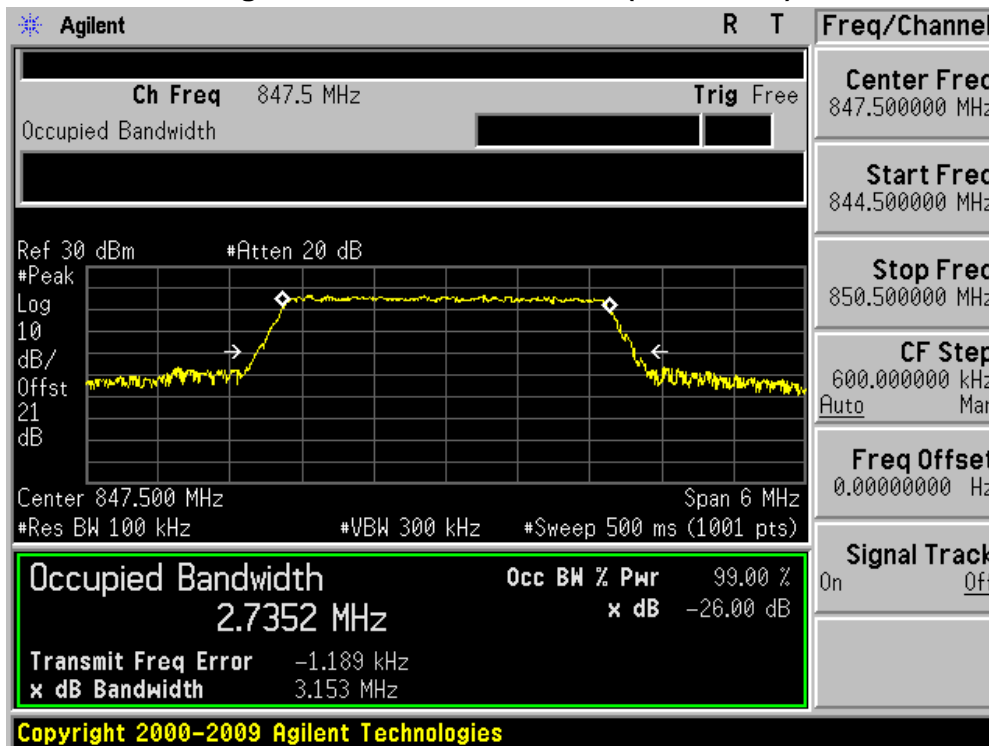

Figure Channel 27025 15RB0 (847.50MHz)



Product	Wireless Module		
Test Item	Occupied Bandwidth		
Test Mode	Mode 1: LTE Band 26(1.4M/QPSK)		
Date of Test	2015/07/09	Test Site	AC6

Channel No.	Frequency (MHz)	99% Occupied Bandwidth (kHz)	-26dB Occupied Bandwidth (kHz)
26797	824.70	1090.80	1290.00
26915	831.50	1090.90	1300.00
27033	848.30	1091.80	1297.00

Figure Channel 26797 7RB0 (824.70MHz)

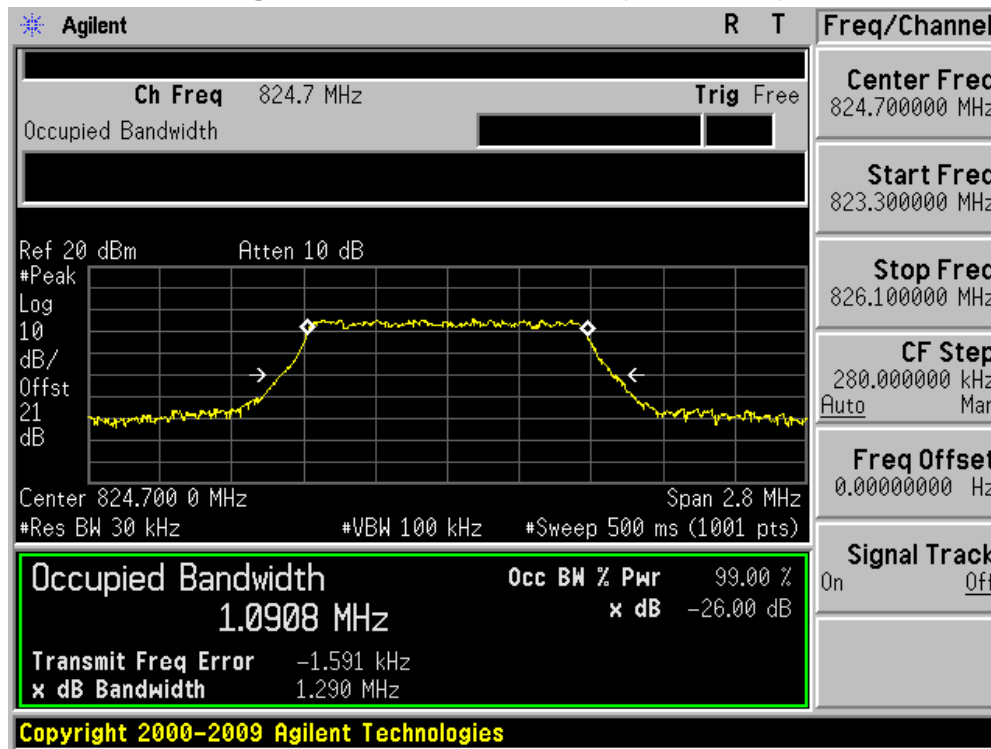

Figure Channel 26915 7RB0 (836.50MHz)

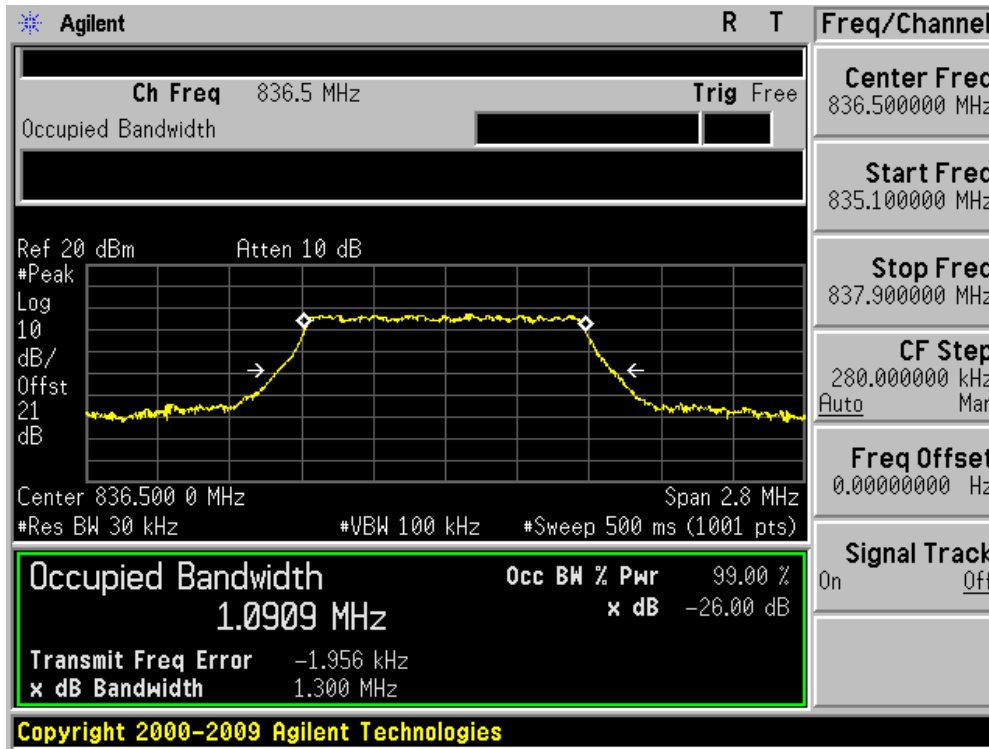
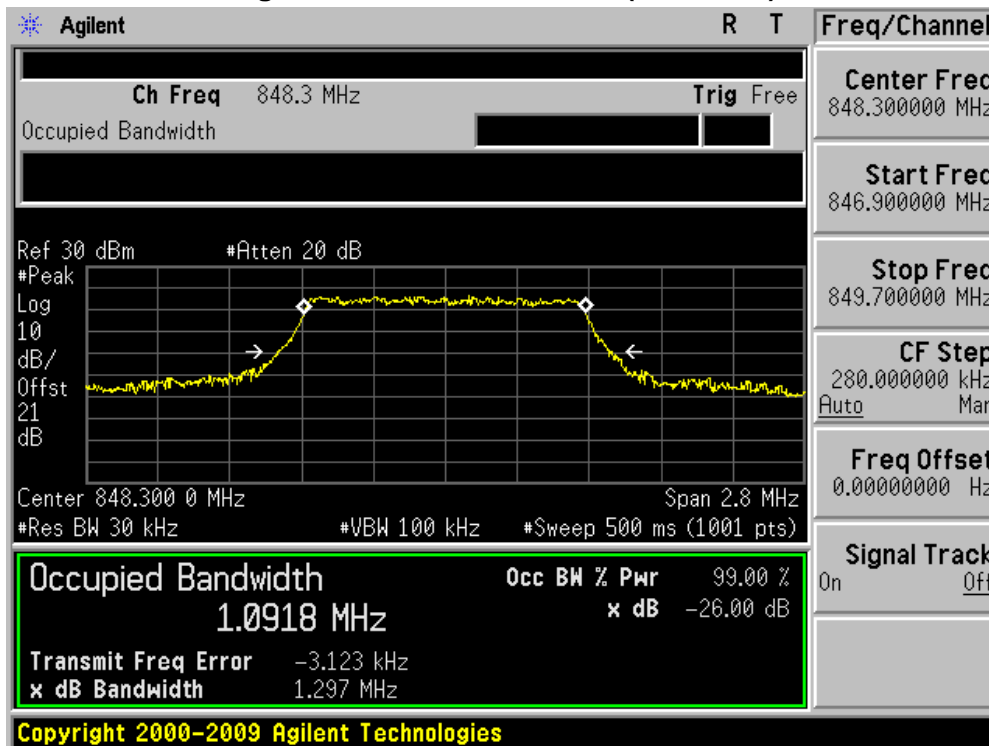

Figure Channel 27033 7RB0 (848.3MHz)



Product	Wireless Module		
Test Item	Occupied Bandwidth		
Test Mode	Mode 1: LTE Band 26 (1.4M/16QAM)		
Date of Test	2015/07/09	Test Site	AC6

Channel No.	Frequency (MHz)	99% Occupied Bandwidth (kHz)	-26dB Occupied Bandwidth (kHz)
26797	824.70	1104.40	1309.00
26915	836.50	1101.10	1306.00
27033	848.30	1100.80	1312.00

Figure Channel 26797 7RB0 (824.70MHz)

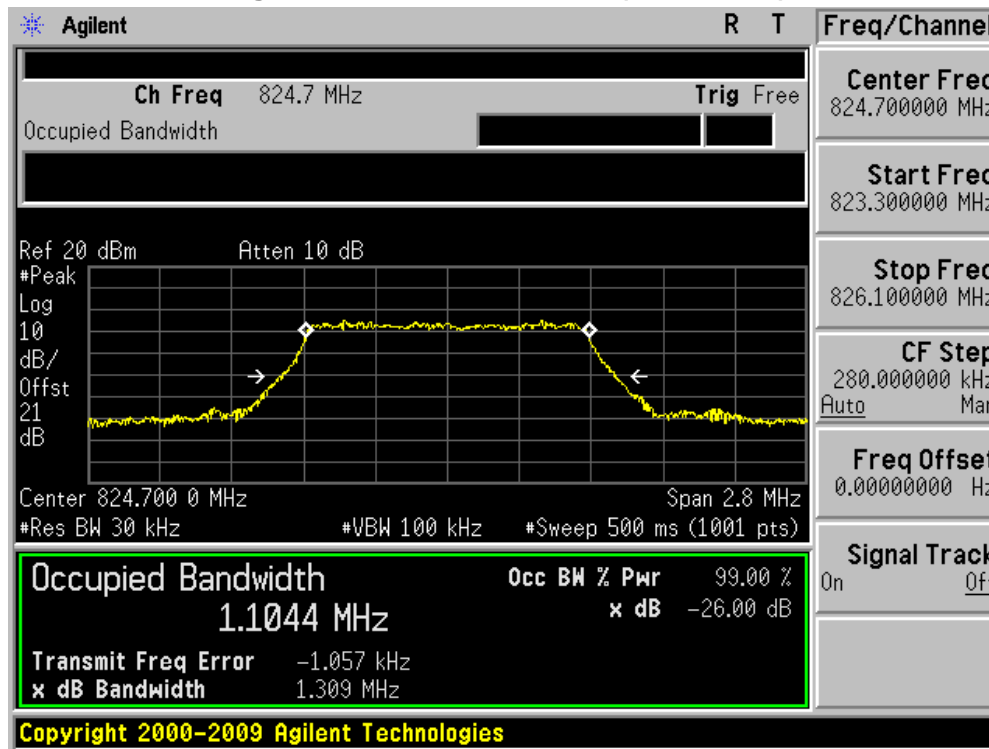

Figure Channel 26915 7RB0 (836.50MHz)

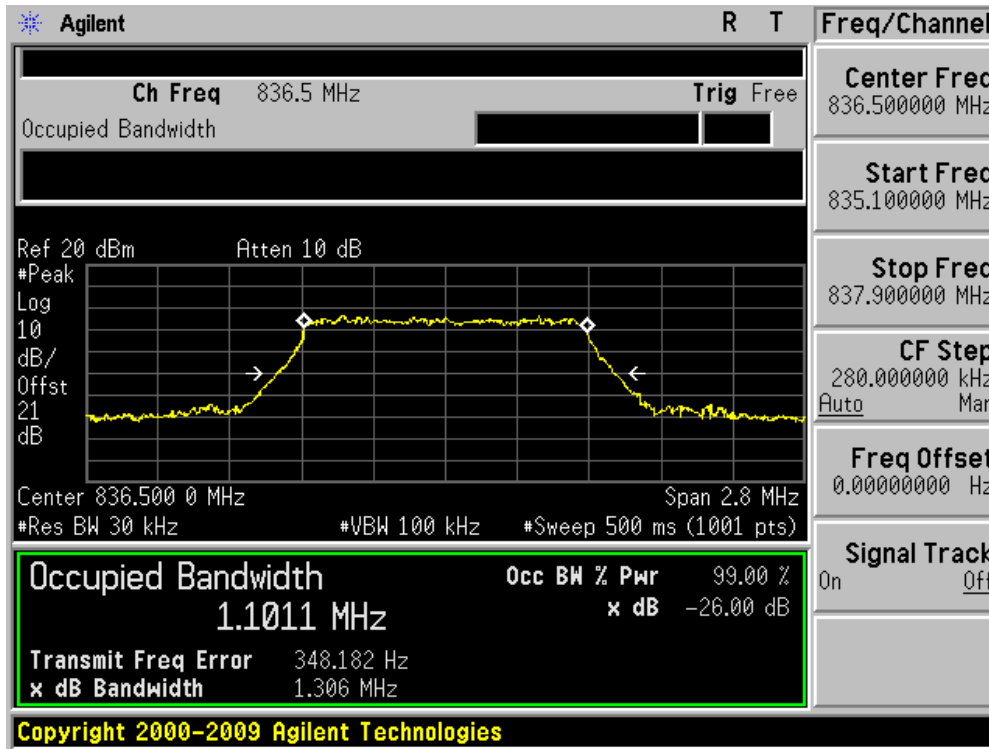
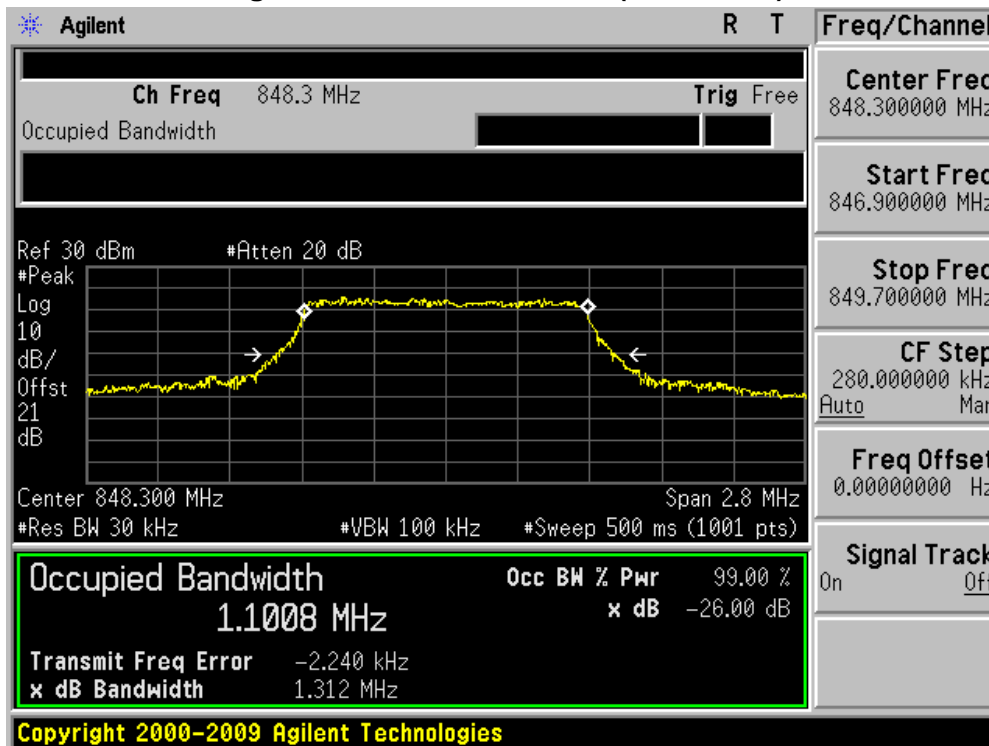

Figure Channel 27033 7RB0 (848.30MHz)



LTE Band 26 For Part 90S

Product	Wireless Module		
Test Item	Occupied Bandwidth		
Test Mode	Mode 1: LTE Band 26(10M/QPSK)		
Date of Test	2015/07/09	Test Site	AC6

Channel No.	Frequency (MHz)	99% Occupied Bandwidth (kHz)	-26dB Occupied Bandwidth (kHz)
26740	819.00	9066.5	10144.00

Figure Channel 26740 50RB0 (819.00MHz)

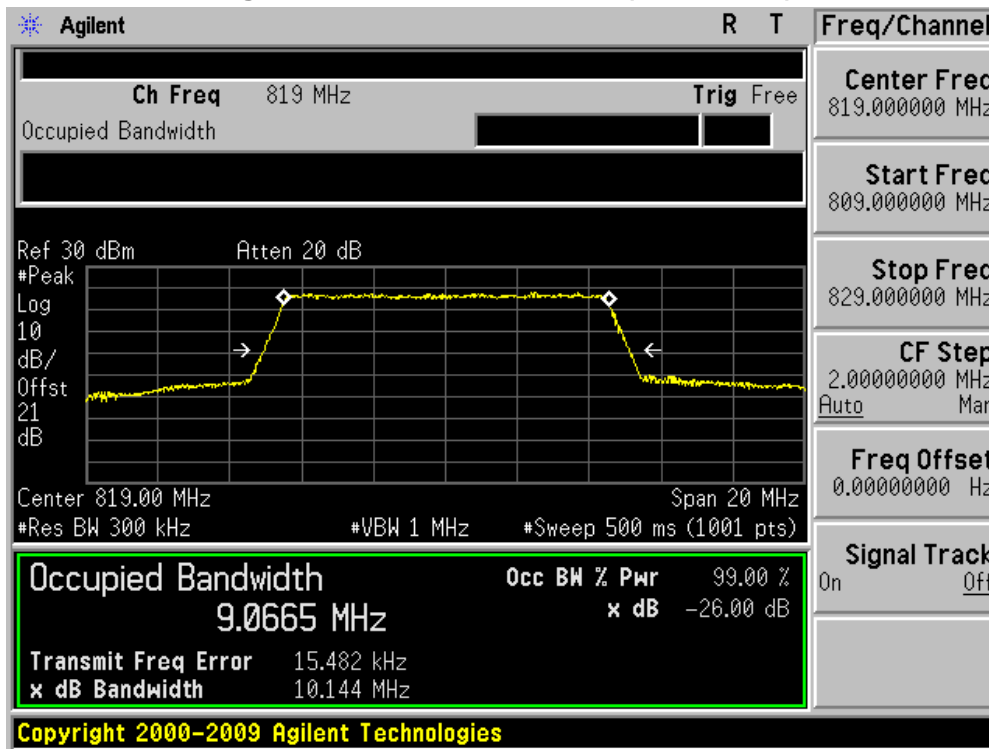

Product	Wireless Module		
Test Item	Occupied Bandwidth		
Test Mode	Mode 1: LTE Band 26 (10M/16QAM)		
Date of Test	2015/07/09	Test Site	AC6

Channel No.	Frequency (MHz)	99% Occupied Bandwidth (kHz)	-26dB Occupied Bandwidth (kHz)
26740	819.00	9016.70	10147.00

Figure Channel 26740 50RB0 (819.00MHz)

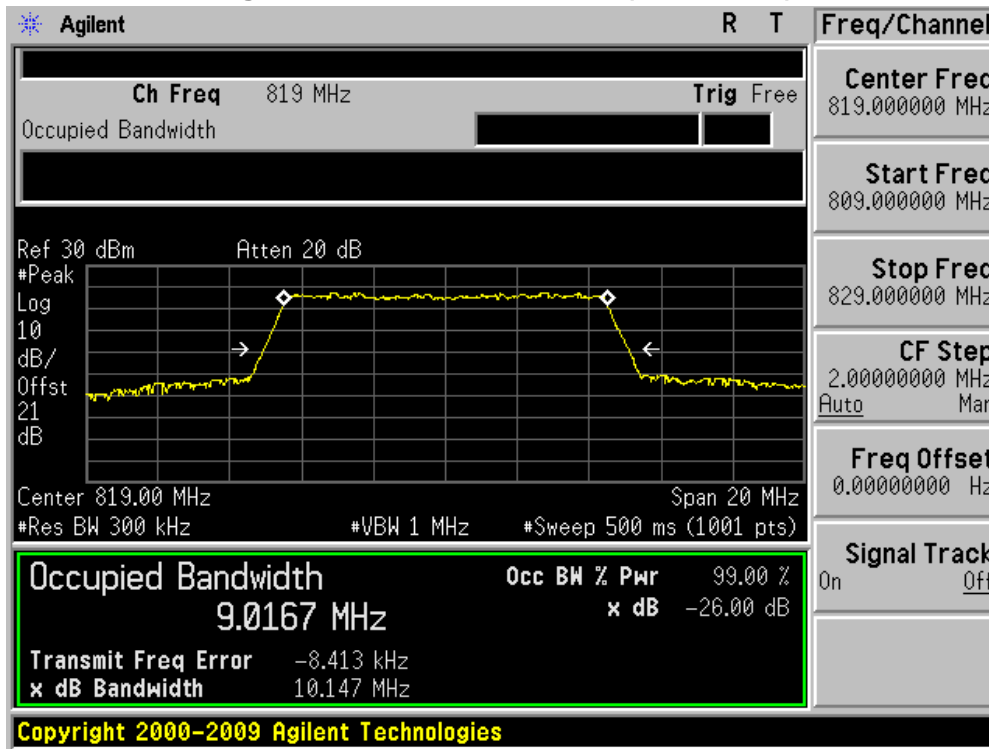

Product	Wireless Module		
Test Item	Occupied Bandwidth		
Test Mode	Mode 1: LTE Band 26(5M/QPSK)		
Date of Test	2015/07/09	Test Site	AC6

Channel No.	Frequency (MHz)	99% Occupied Bandwidth (kHz)	-26dB Occupied Bandwidth (kHz)
26715	816.50	4503.90	5073.00
26740	819.00	4503.70	5057.00
26765	821.50	4502.50	5071.00

Figure Channel 26715 25RB0 (816.50MHz)

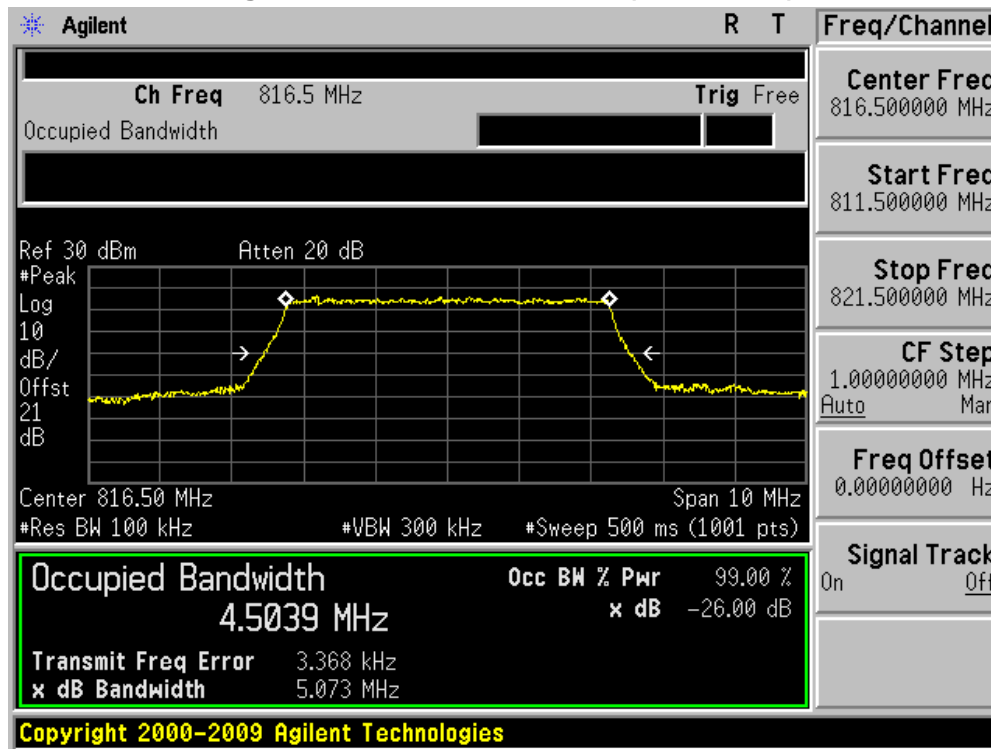

Figure Channel 26740 25RB0 (819.00MHz)

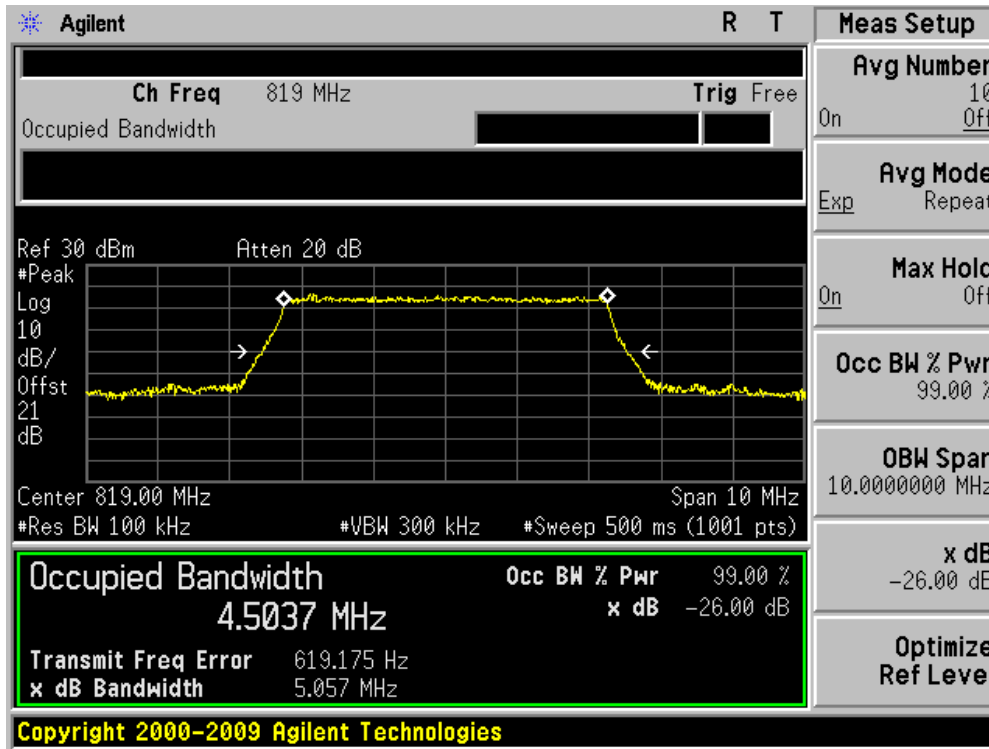
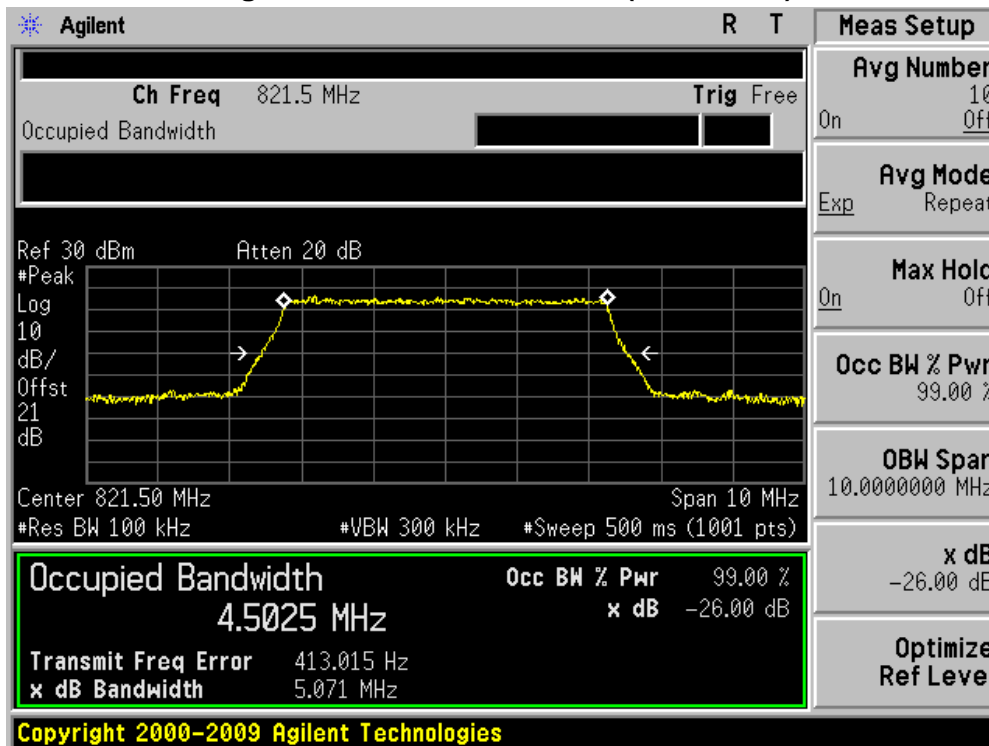

Figure Channel 26765 25RB0 (821.50MHz)



Product	Wireless Module		
Test Item	Occupied Bandwidth		
Test Mode	Mode 1: LTE Band 26 (5M/16QAM)		
Date of Test	2015/07/09	Test Site	AC6

Channel No.	Frequency (MHz)	99% Occupied Bandwidth (kHz)	-26dB Occupied Bandwidth (kHz)
26715	816.50	4485.60	5015.00
26740	819.00	4488.00	5020.00
26765	821.50	4488.00	5020.00

Figure Channel 26715 25RB0 (816.50MHz)

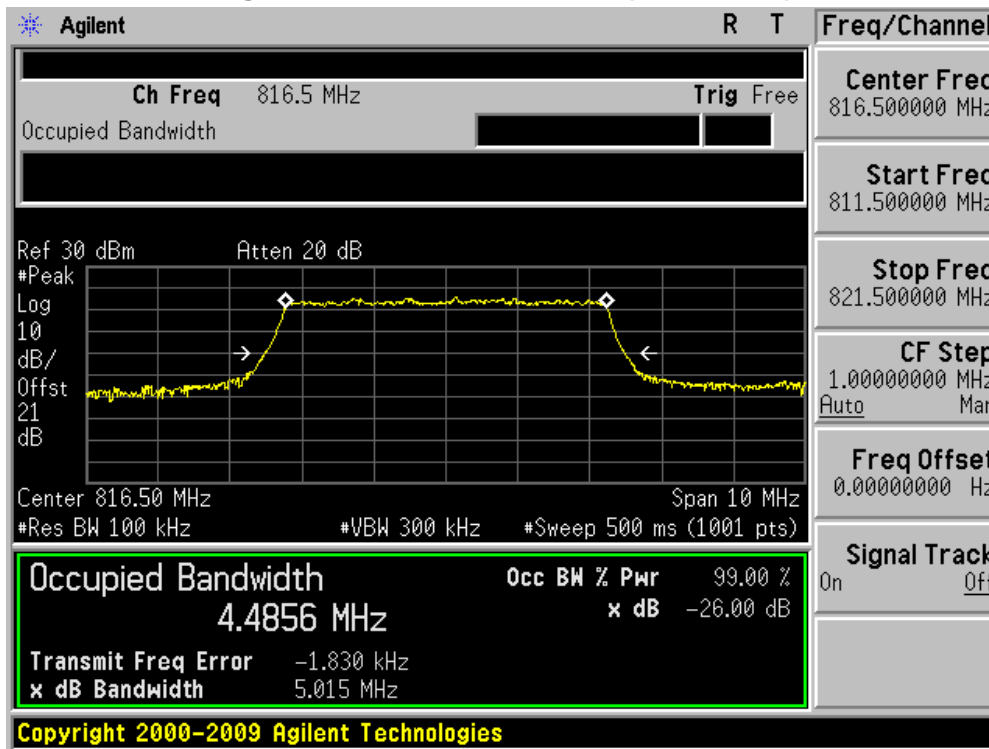

Figure Channel 26740 25RB0 (819.00MHz)

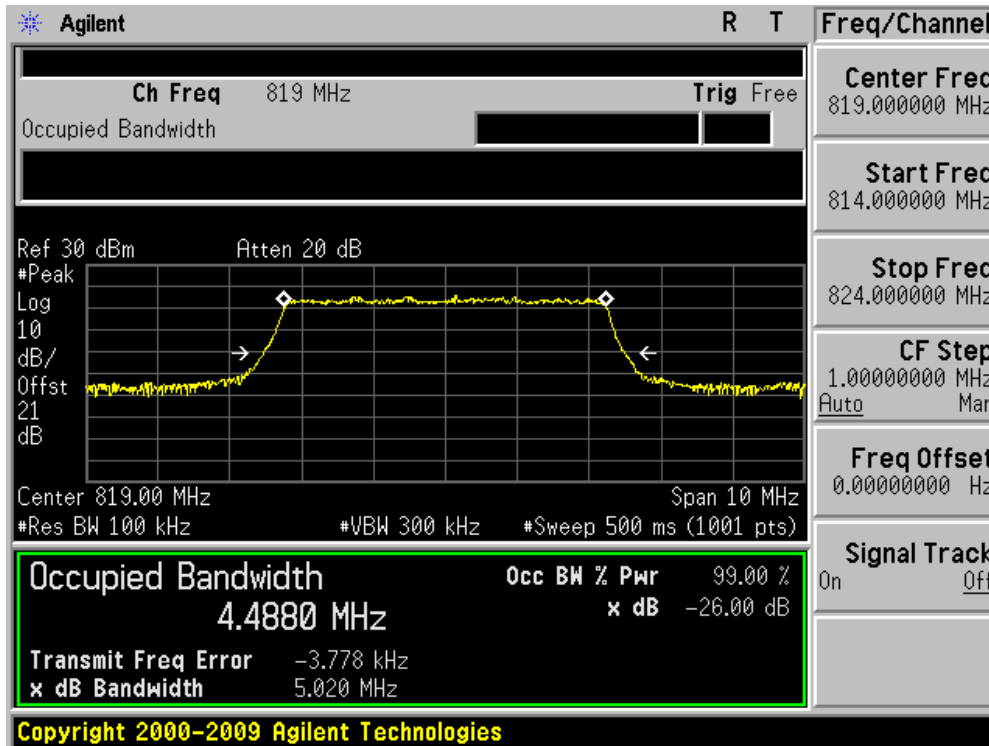
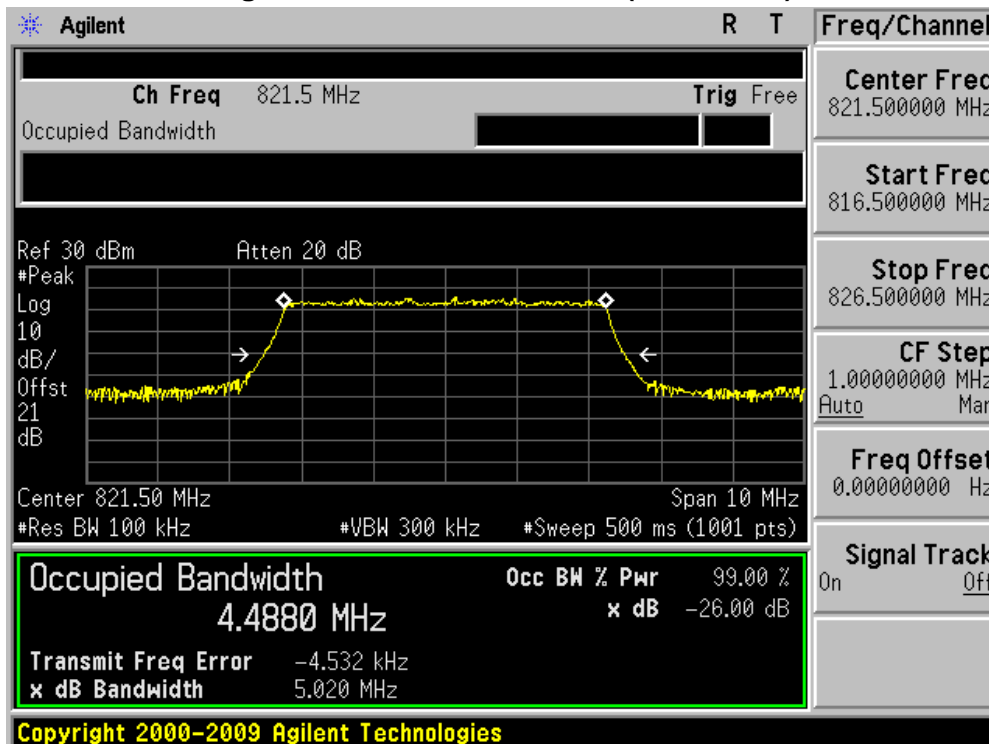

Figure Channel 26765 25RB0 (821.50MHz)



Product	Wireless Module		
Test Item	Occupied Bandwidth		
Test Mode	Mode 1: LTE Band 26(3M/QPSK)		
Date of Test	2015/07/09	Test Site	AC6

Channel No.	Frequency (MHz)	99% Occupied Bandwidth (kHz)	-26dB Occupied Bandwidth (kHz)
26705	815.50	2730.70	3145.00
26740	819.00	2730.60	3110.00
26775	822.50	2727.20	3125.00

Figure Channel 26705 15RB0 (815.50MHz)

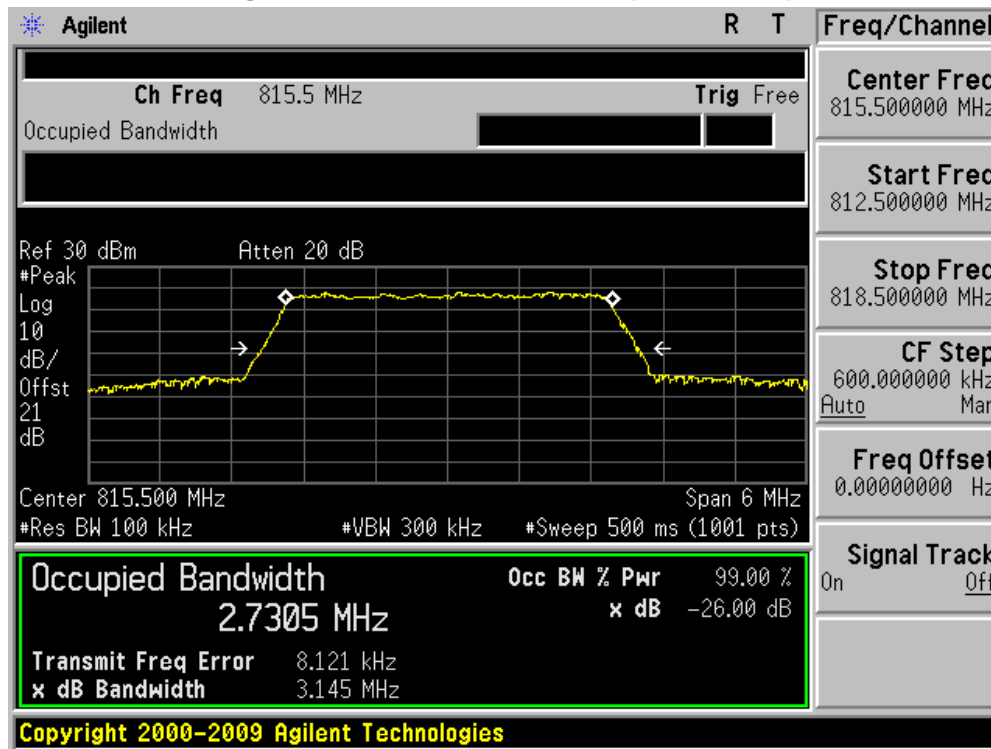

Figure Channel 26740 15RB0 (831.50MHz)

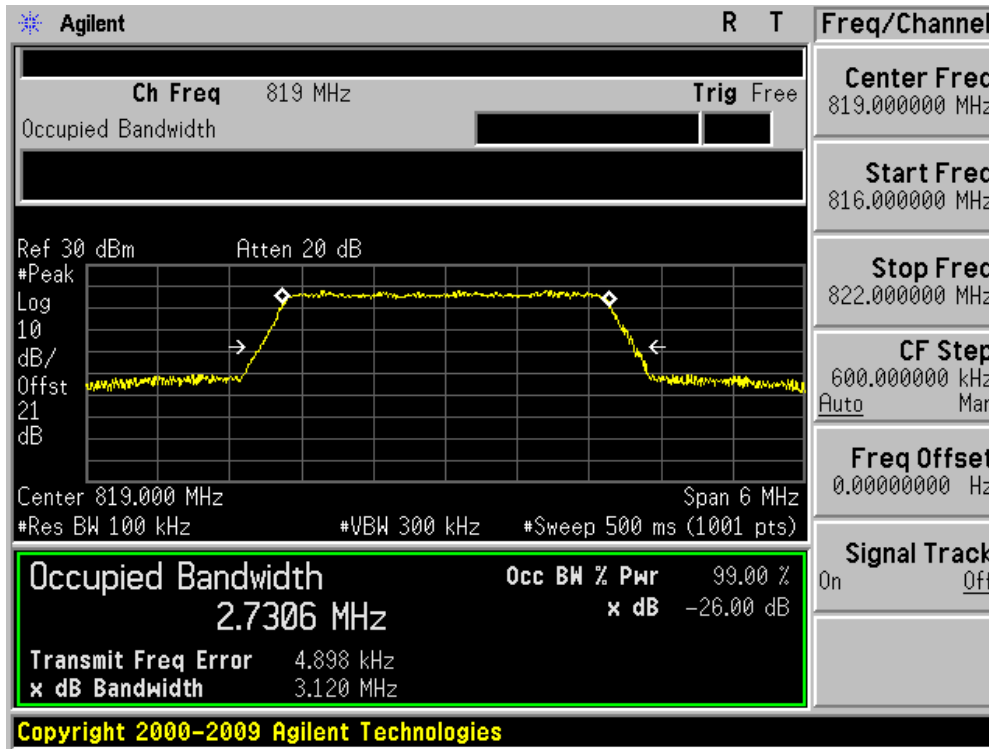
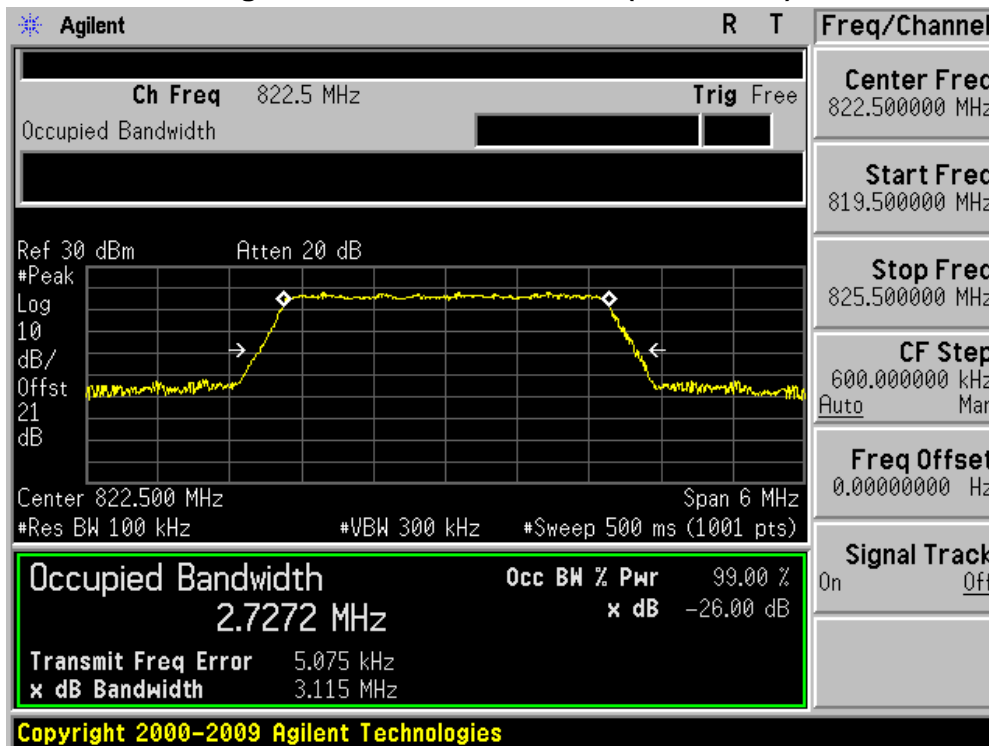

Figure Channel 26775 15RB0 (847.50MHz)



Product	Wireless Module		
Test Item	Occupied Bandwidth		
Test Mode	Mode 1: LTE Band 26 (3M/16QAM)		
Date of Test	2015/07/09	Test Site	AC6

Channel No.	Frequency (MHz)	99% Occupied Bandwidth (kHz)	-26dB Occupied Bandwidth (kHz)
26705	815.50	2750.40	3181.00
26740	819.00	2740.70	3166.00
26775	822.50	2741.00	3169.00

Figure Channel 26705 15RB0 (815.50MHz)

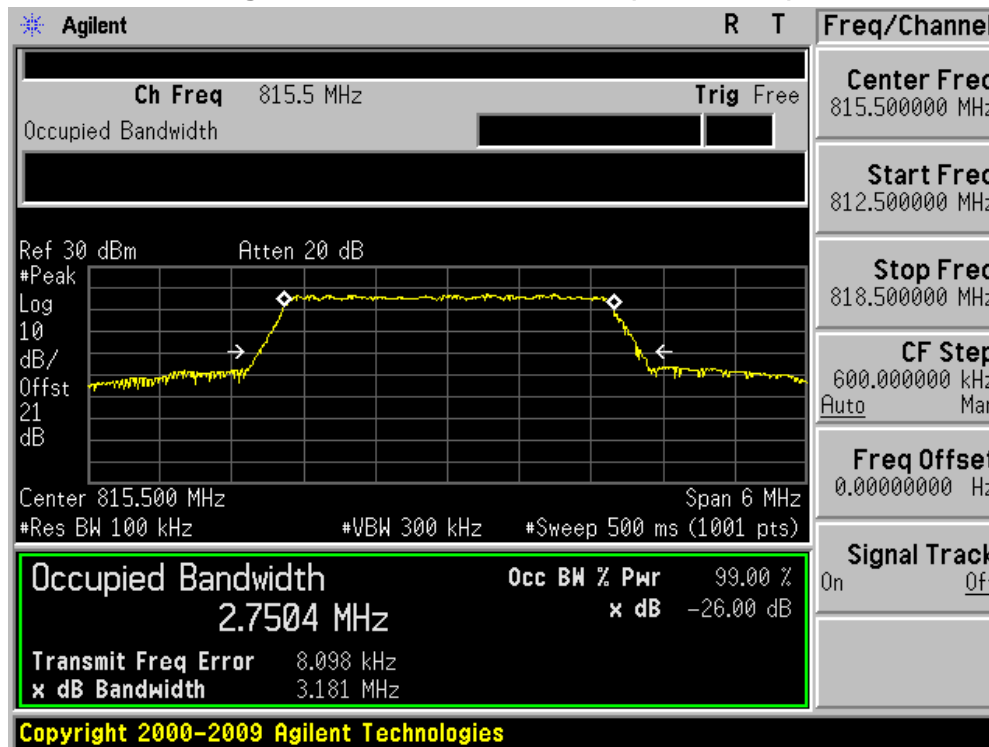

Figure Channel 26740 15RB0 (831.50MHz)

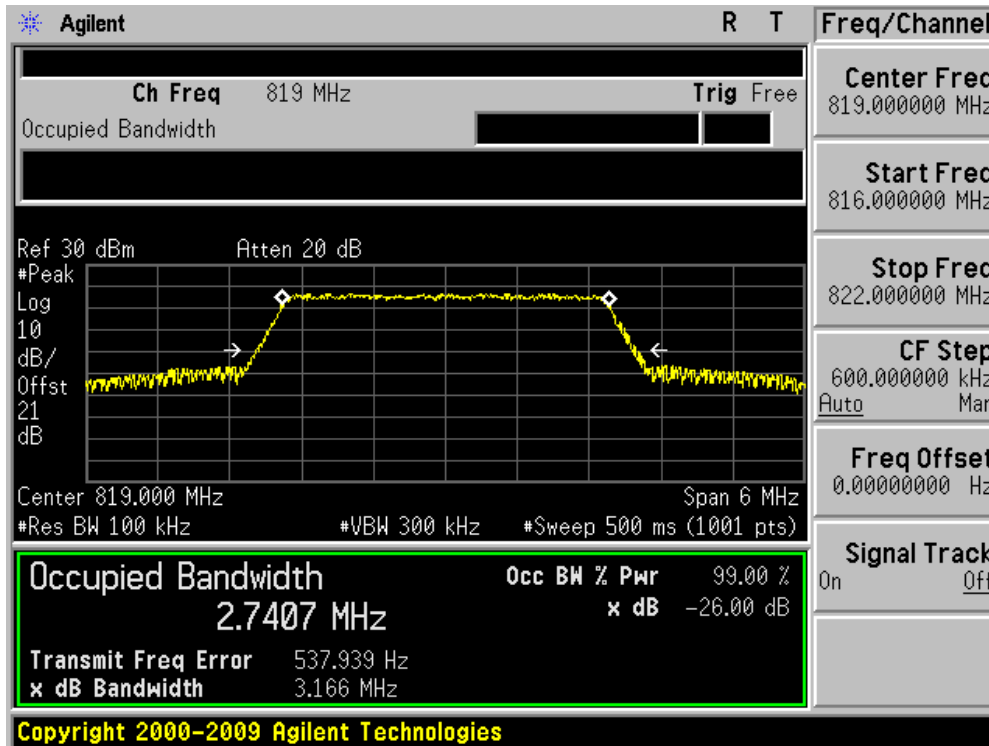
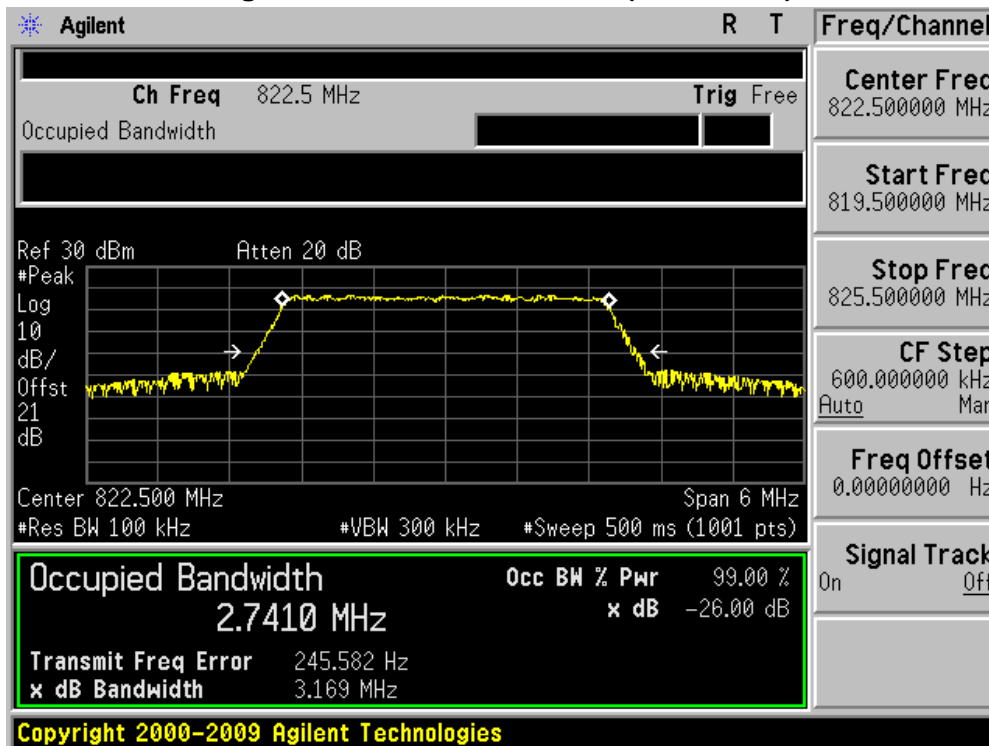

Figure Channel 26775 15RB0 (847.50MHz)



Product	Wireless Module		
Test Item	Occupied Bandwidth		
Test Mode	Mode 1: LTE Band 26(1.4M/QPSK)		
Date of Test	2015/07/09	Test Site	AC6

Channel No.	Frequency (MHz)	99% Occupied Bandwidth (kHz)	-26dB Occupied Bandwidth (kHz)
26697	814.70	1092.20	1299.00
26740	819.00	1091.80	1299.00
26783	823.30	1090.60	1293.00

Figure Channel 26697 7RB0 (814.70MHz)

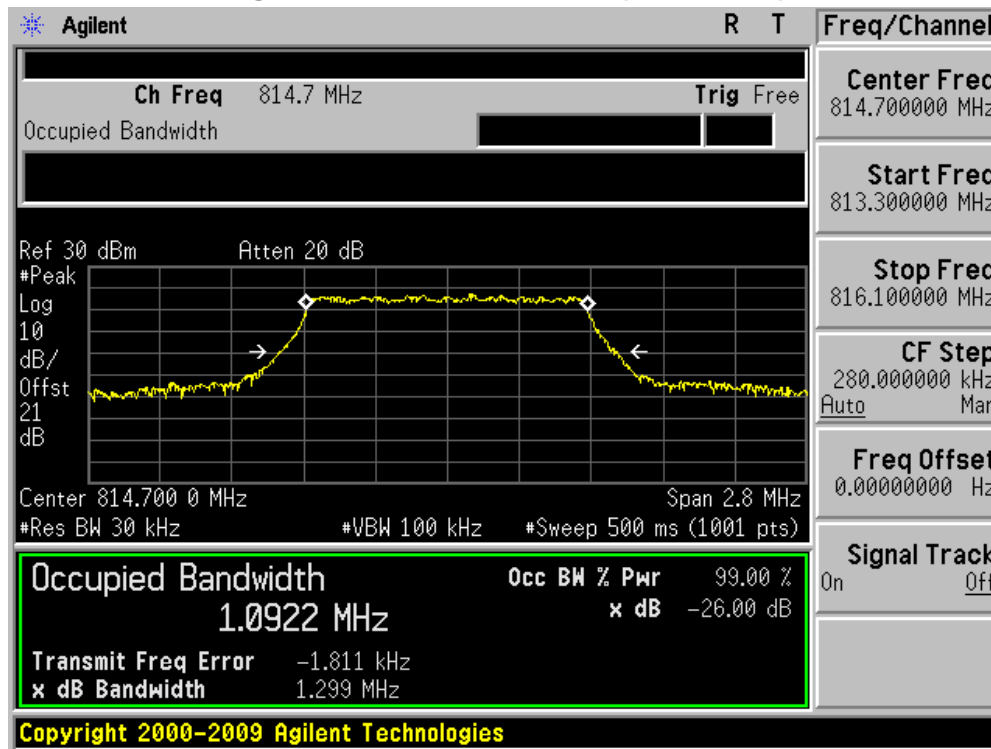

Figure Channel 26740 7RB0 (819.00MHz)

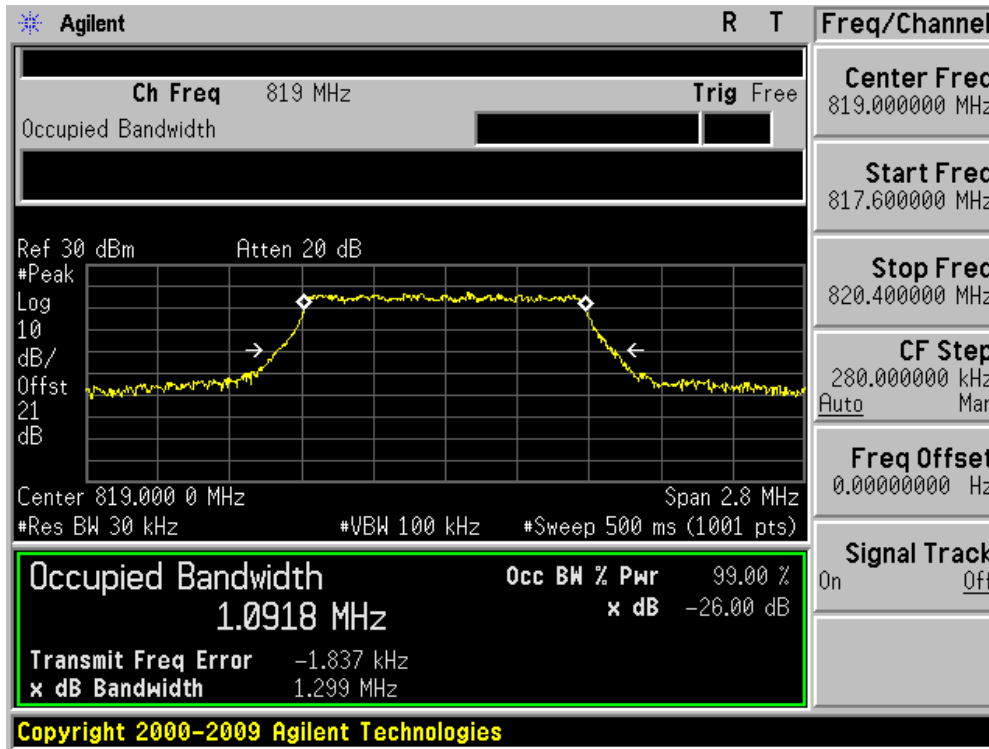
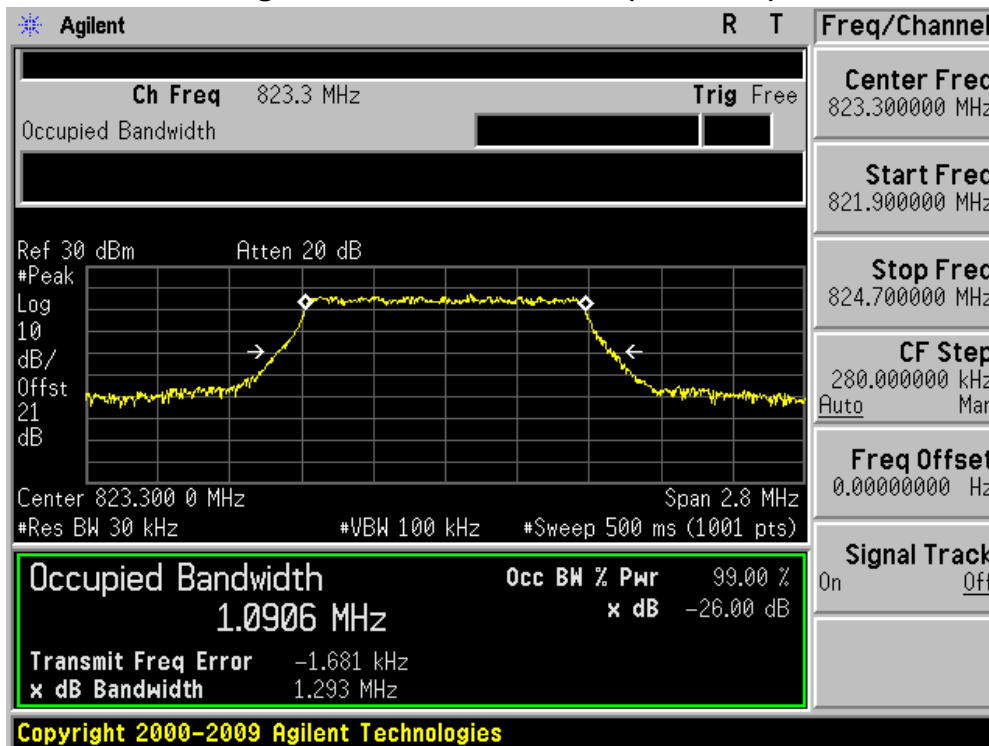

Figure Channel 26783 7RB0 (823.3MHz)



Product	Wireless Module		
Test Item	Occupied Bandwidth		
Test Mode	Mode 1: LTE Band 26 (1.4M/16QAM)		
Date of Test	2015/07/09	Test Site	AC6

Channel No.	Frequency (MHz)	99% Occupied Bandwidth (kHz)	-26dB Occupied Bandwidth (kHz)
26697	814.70	1101.90	1308.00
26740	819.00	1100.50	1315.00
26783	823.30	1099.10	1311.00

Figure Channel 26697 7RB0 (814.70MHz)

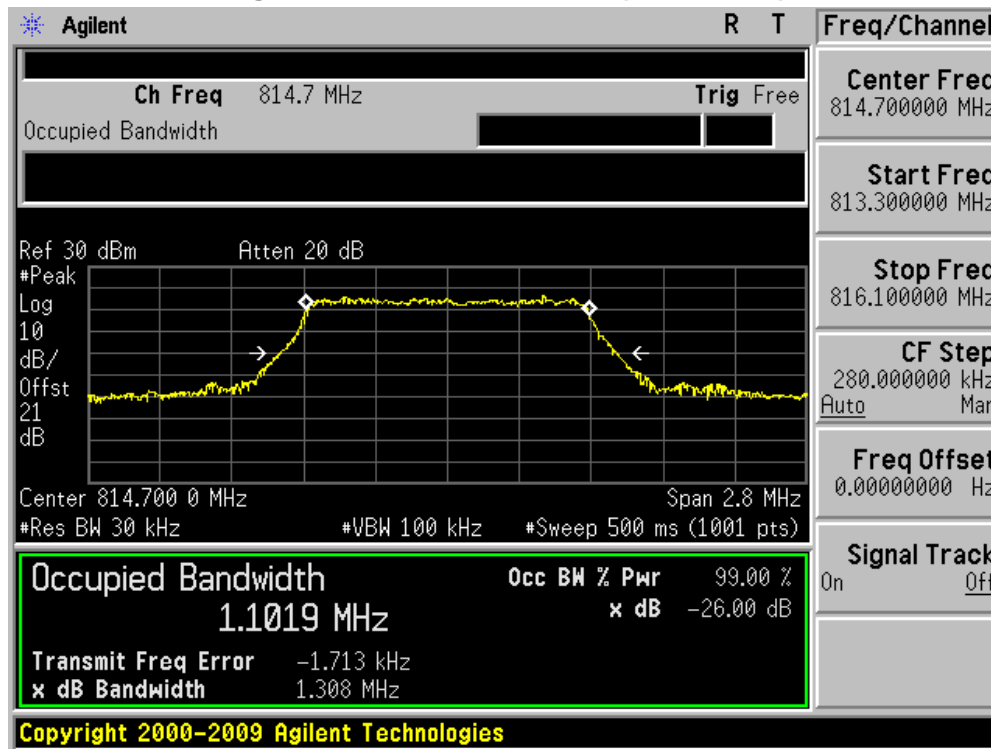

Figure Channel 26740 7RB0 (819.00MHz)

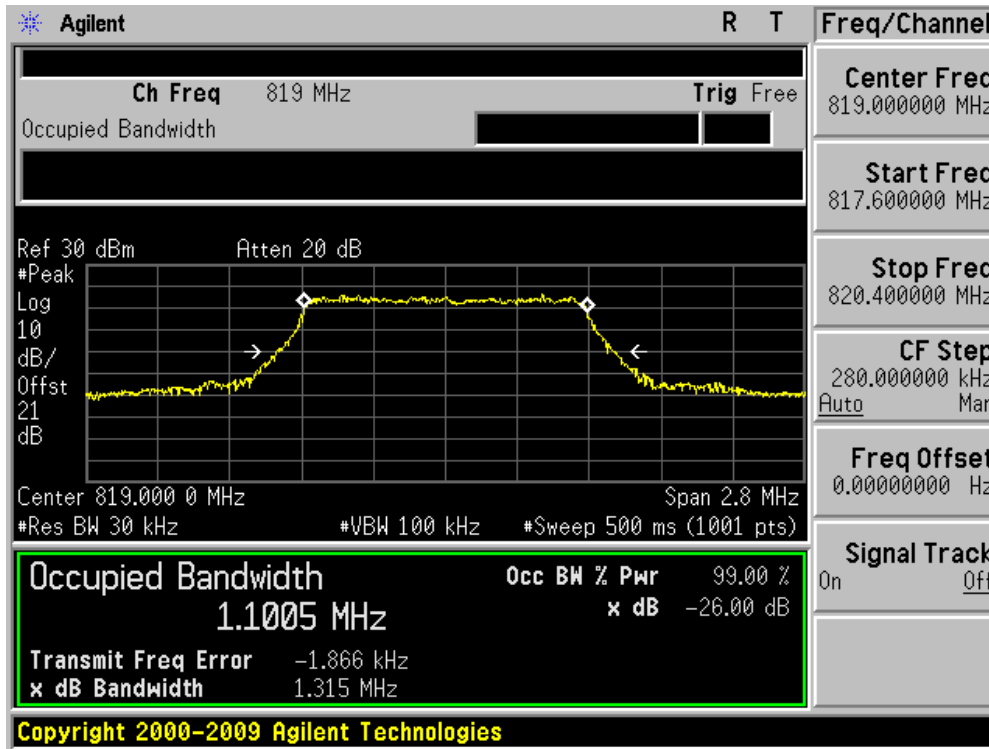
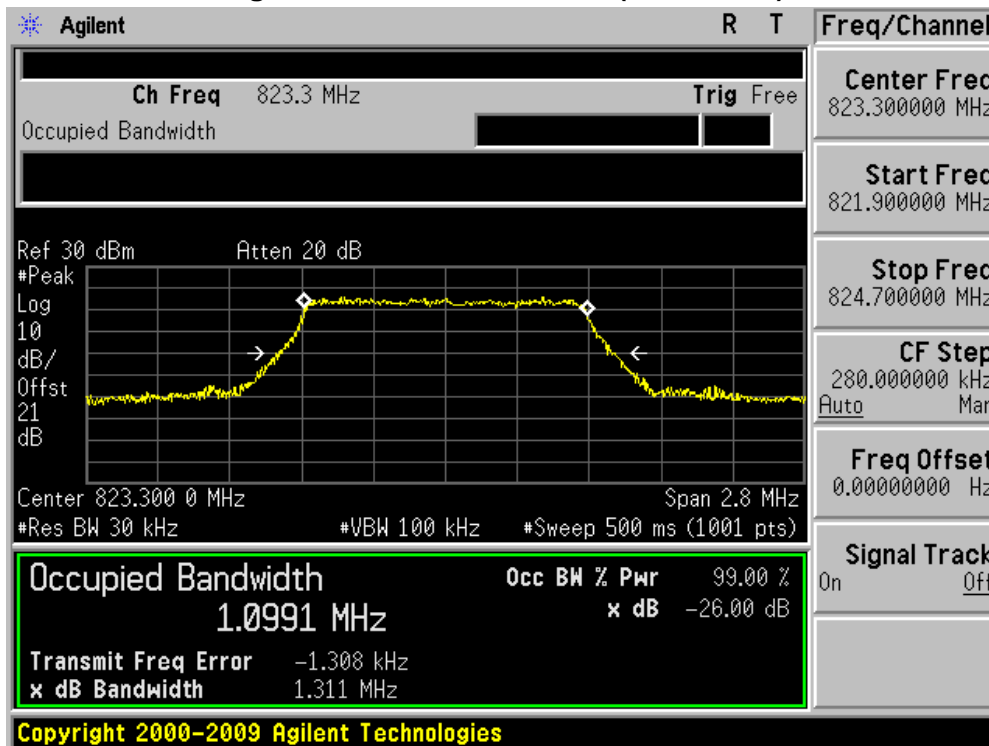

Figure Channel 26783 7RB0 (823.30MHz)



6. Conducted Band Edge

6.1. Test Equipment

Spurious Emission At Antenna Terminals (+/- 1MHz) / AC-6

Instrument	Manufacturer	Type No.	Serial No	Cali. Due Date
PSA Series Spectrum Analyzer	Agilent	E4440A	MY49420184	2016/03/10
Radio Communication Tester	R&S	CMU 200	117088	2016/03/10
Dual Directional Coupler	Agilent	778D	20160	2016/03/10
10dB Coaxial Coupler	Agilent	87300C	MY44300299	2016/03/10
Temperature/Humidity Meter	Zhicheng	ZC1-2	AC6-TH	2016/01/07

6.2. Test Setup

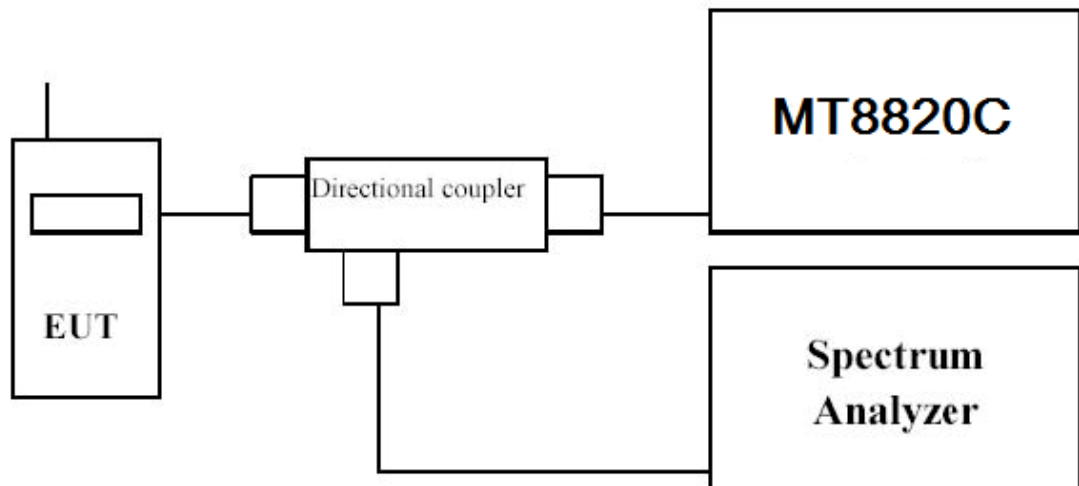

6.3. Test Procedure

1. The EUT was connected to spectrum analyzer and System Simulator via power divider.
2. The RF output of EUT was connected to the spectrum analyzer by RF cable and attenuator. The path loss was compensated to the results for each measurement.
3. The conducted spurious emission for the whole frequency range was taken.

6.4. Uncertainty

The measurement uncertainty is defined as ± 1.2 dB.

6.5. Test Result

LTE Band 26 For Part 22H

Product	Wireless Module		
Test Item	Conducted Band Edge		
Test Mode	Mode 1: LTE Band 26 (15M/QPSK)		
Date of Test	2015/07/09	Test Site	AC6

Figure Channel 26865 (831.50MHz)

1RB0

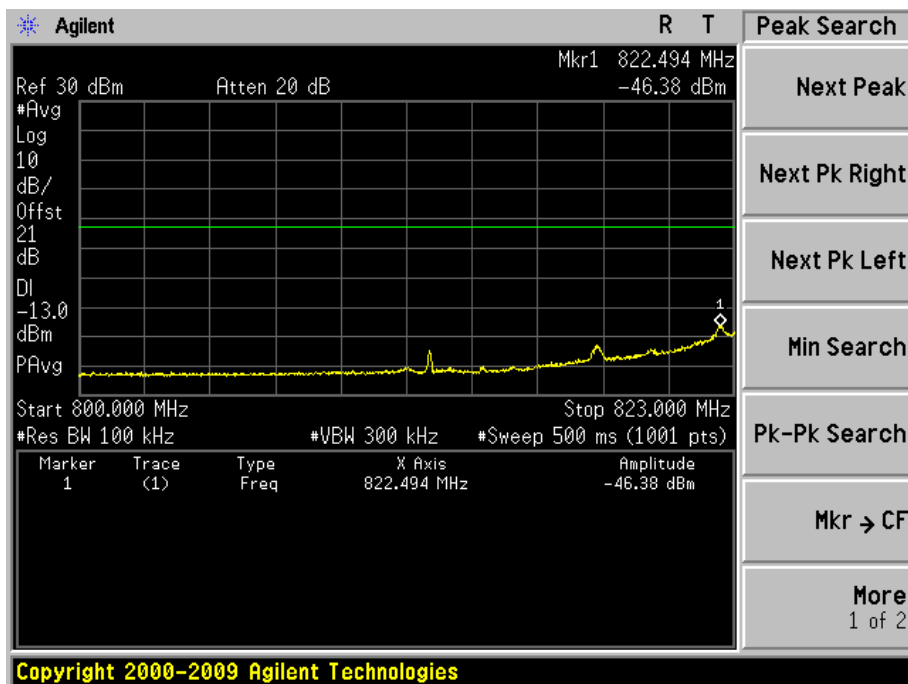
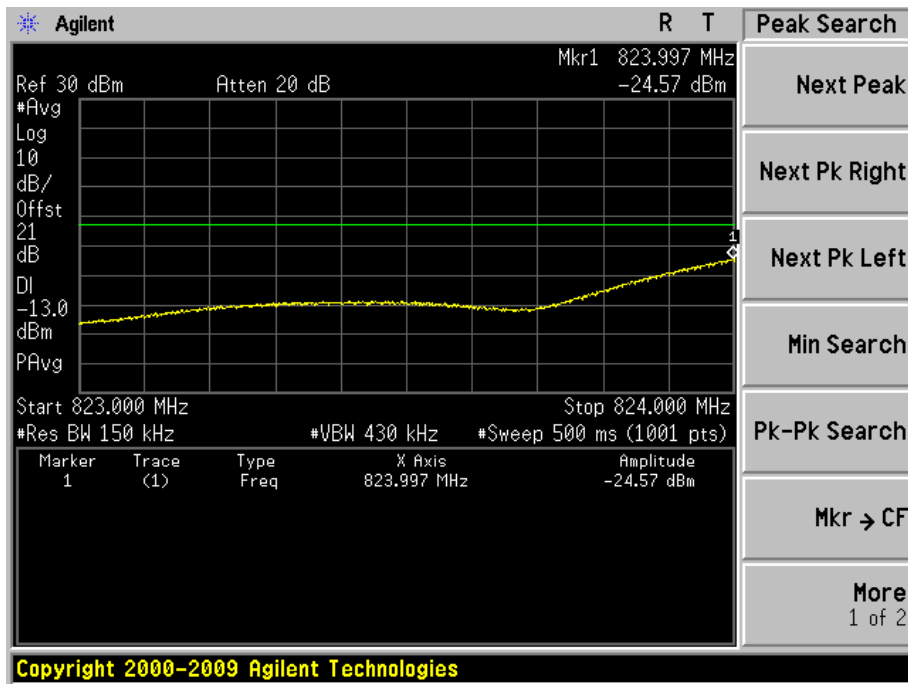

75RB0

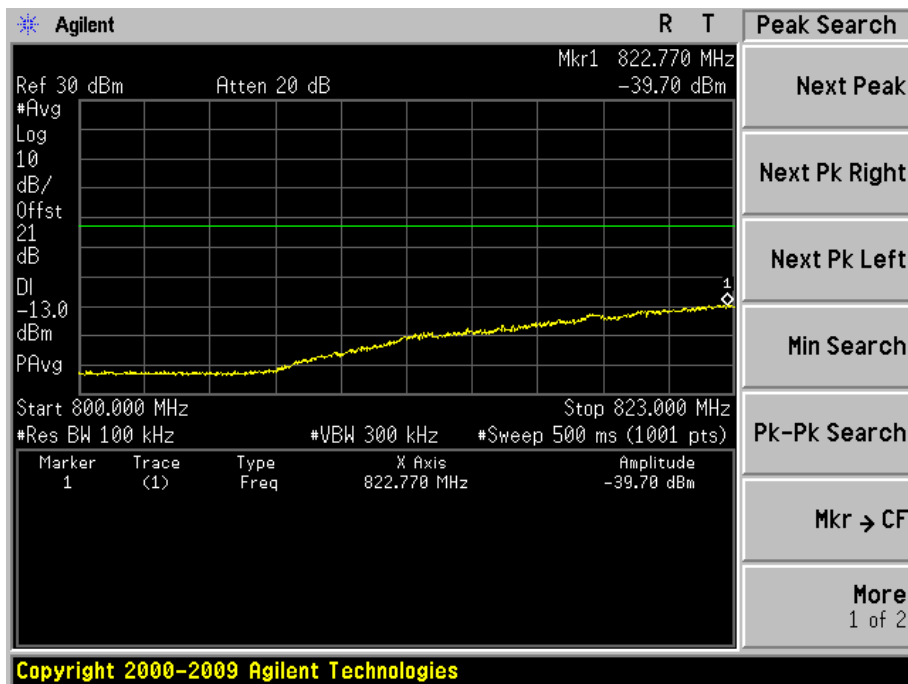
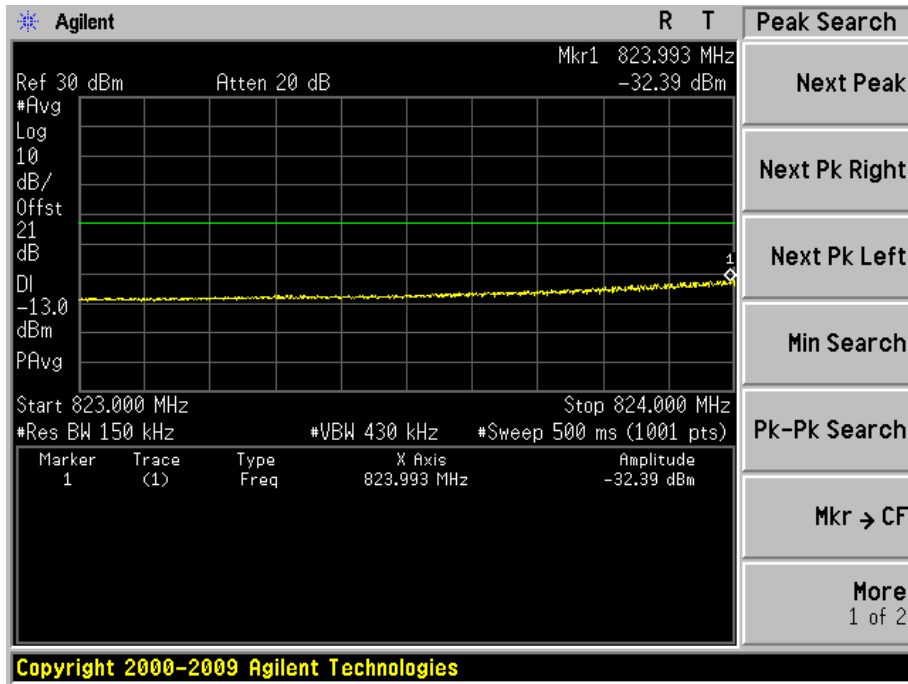
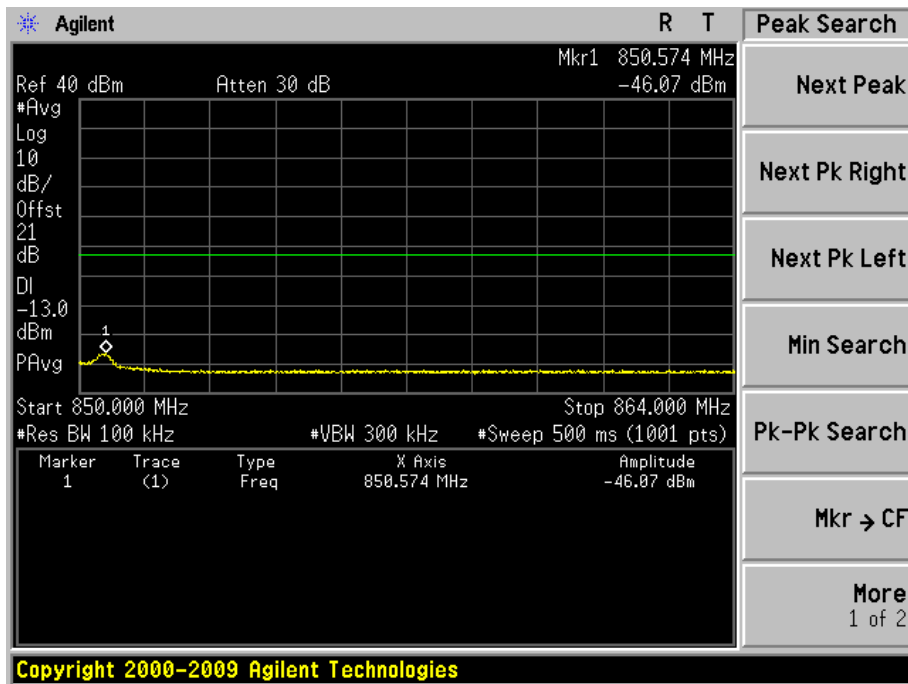
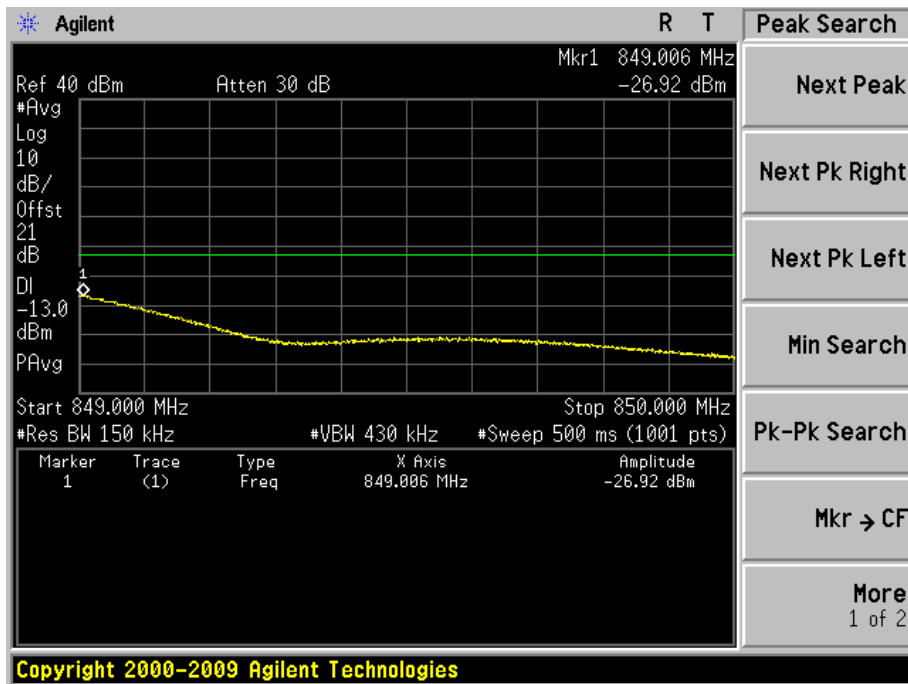
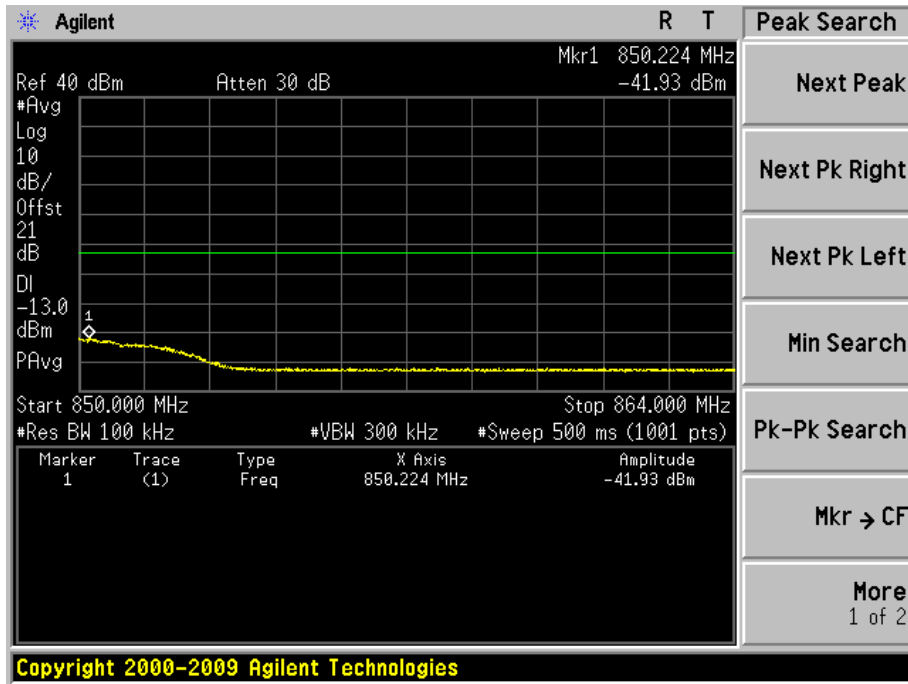
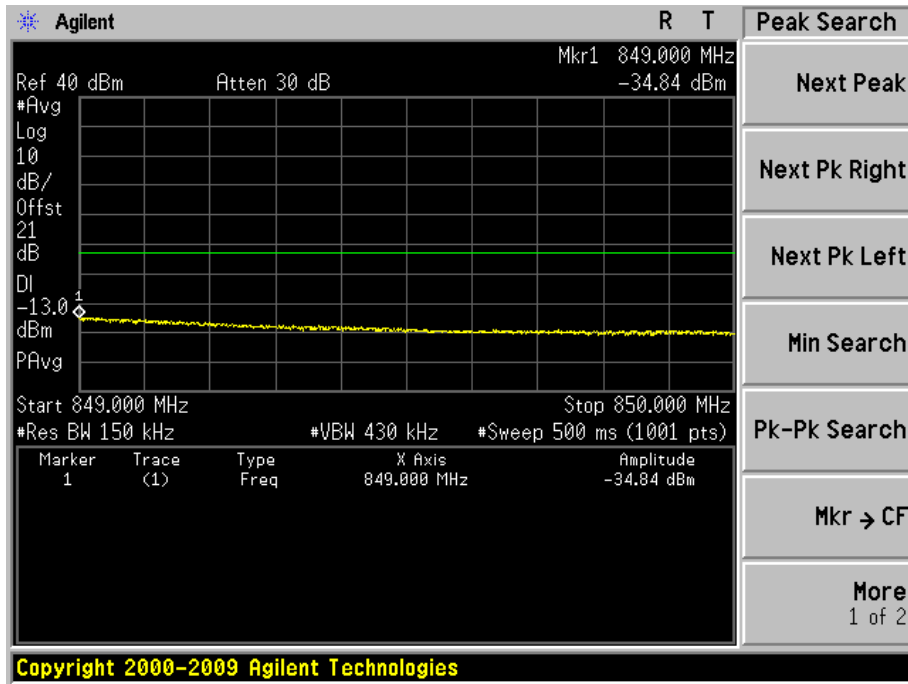

Figure Channel 26965 (841.5MHz)
1RB74



75RB0



Product	Wireless Module		
Test Item	Conducted Band Edge		
Test Mode	Mode 1: LTE Band 26 (15M/16QAM)		
Date of Test	2015/07/09	Test Site	AC6

Figure Channel 26865 (831.50MHz)
1RB0

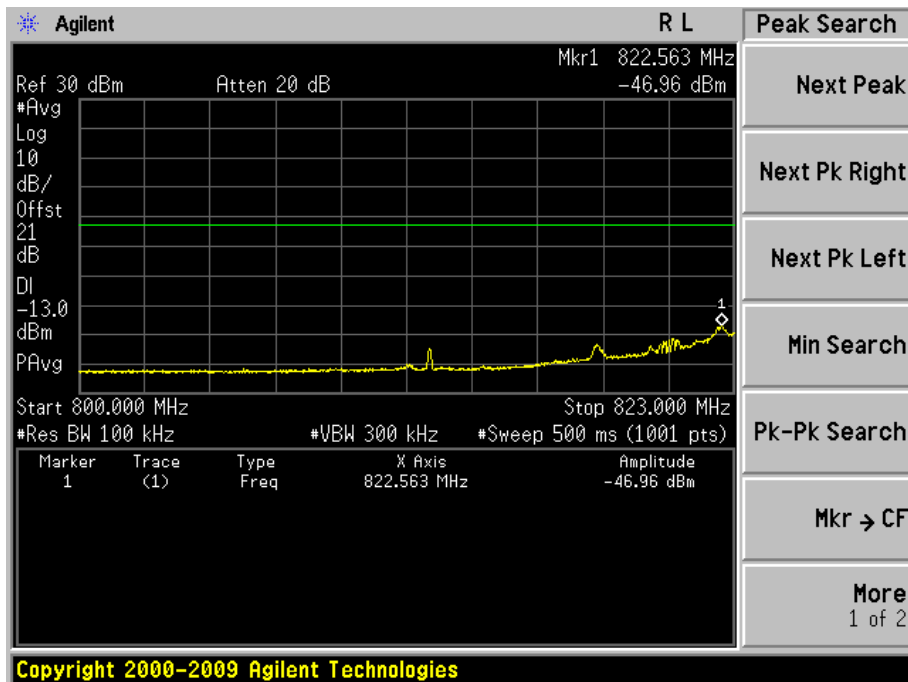
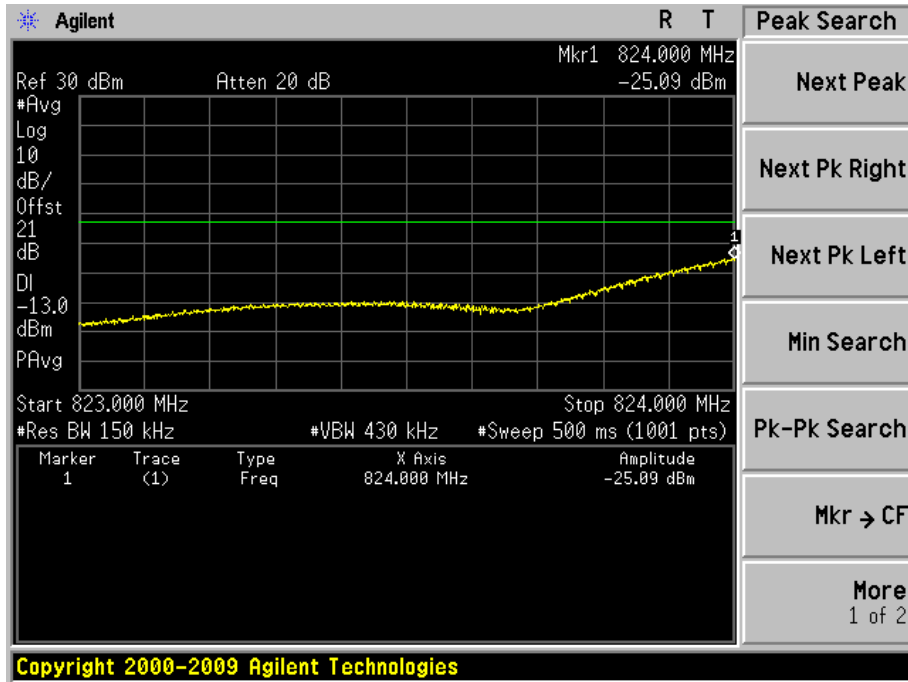

75RB0

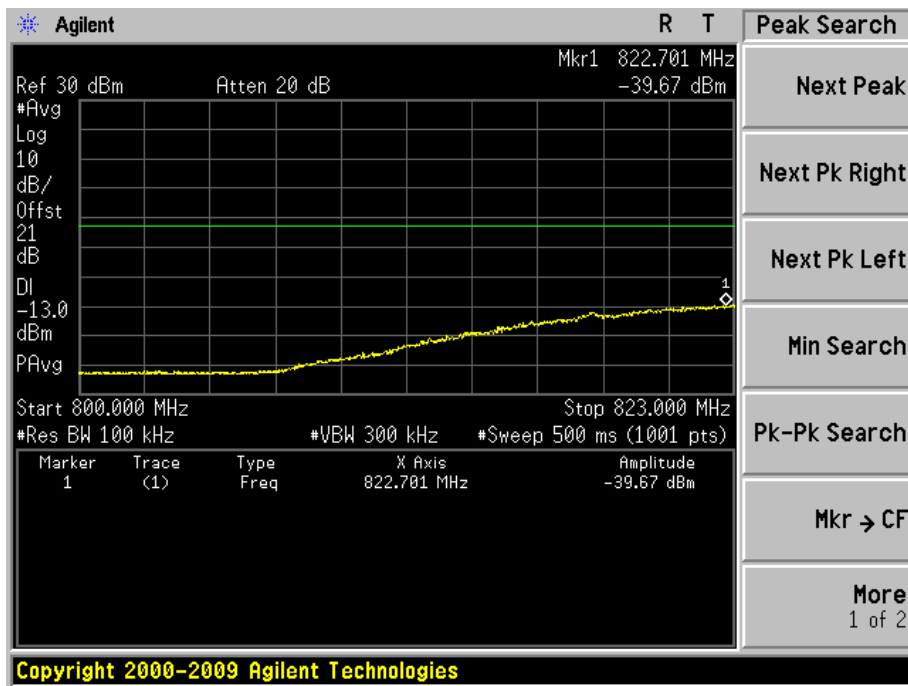
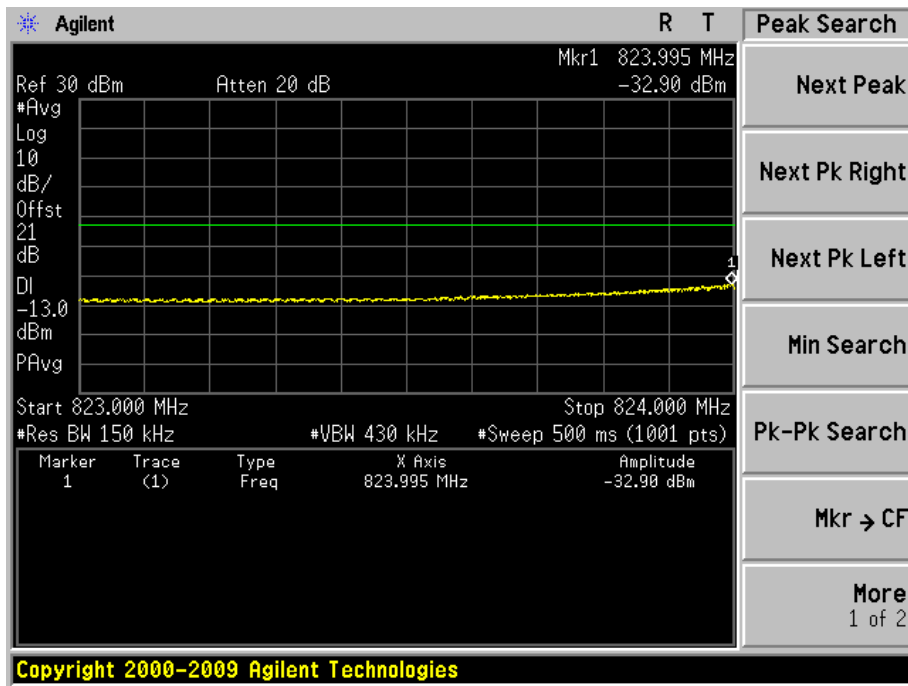
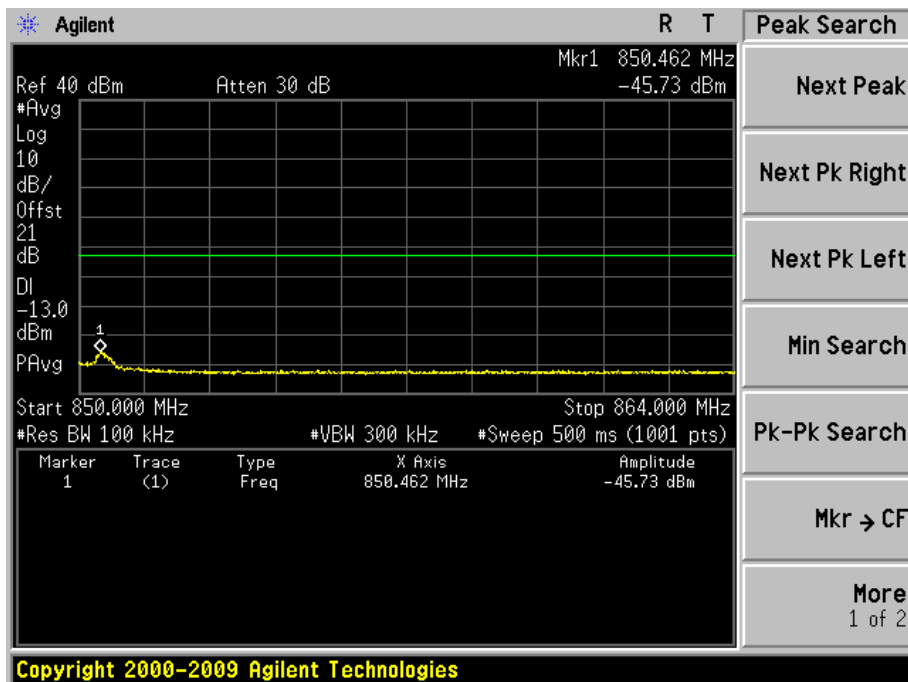
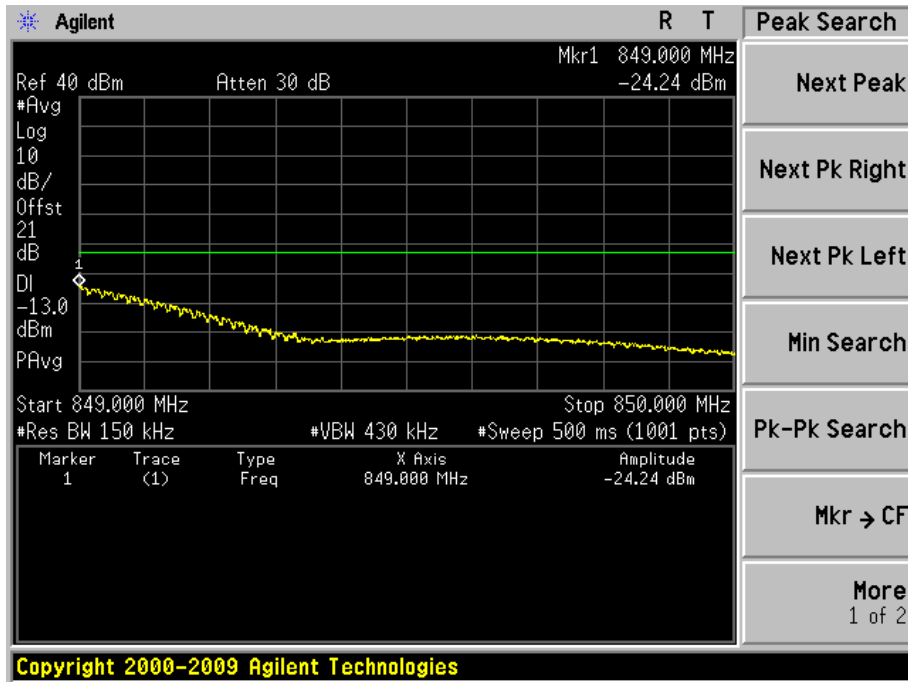
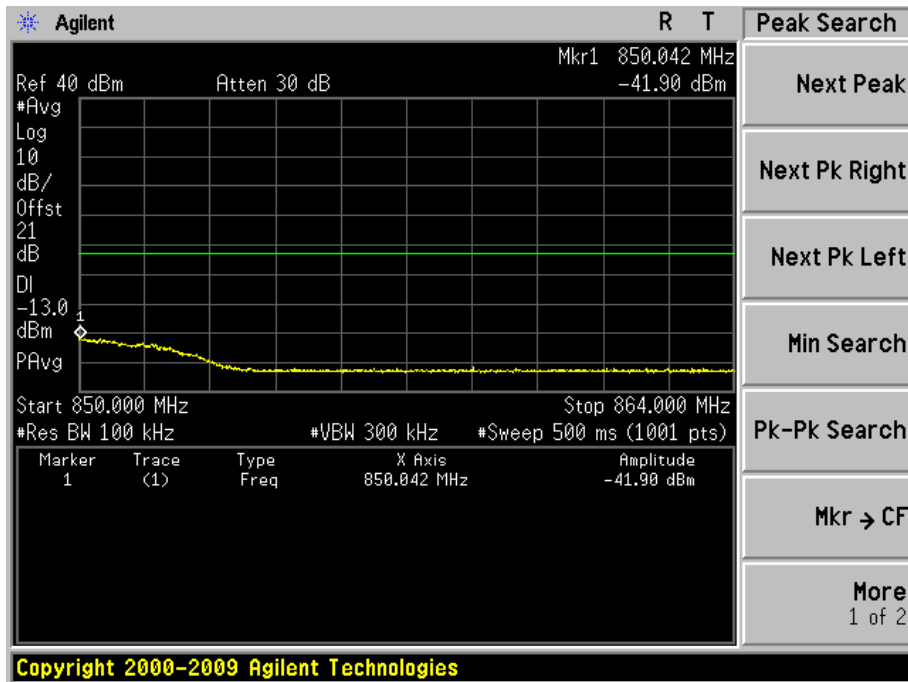
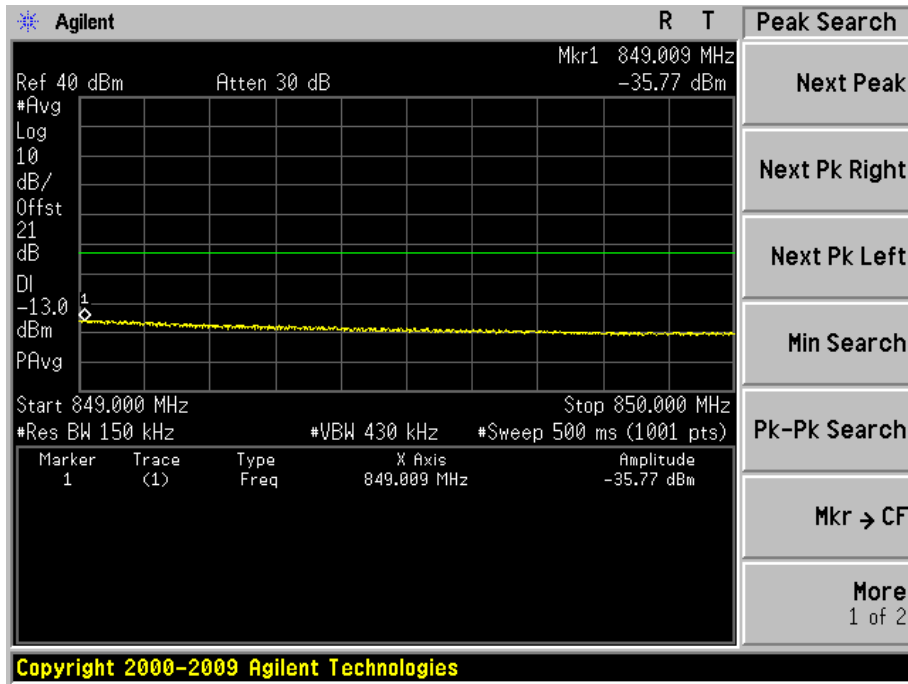

Figure Channel 26965 (841.50MHz)

1RB74



75RB0



Product	Wireless Module		
Test Item	Conducted Band Edge		
Test Mode	Mode 1: LTE Band 26 (10M/QPSK)		
Date of Test	2015/07/09	Test Site	AC6

Figure Channel 26840 (829.00MHz)
1RB0

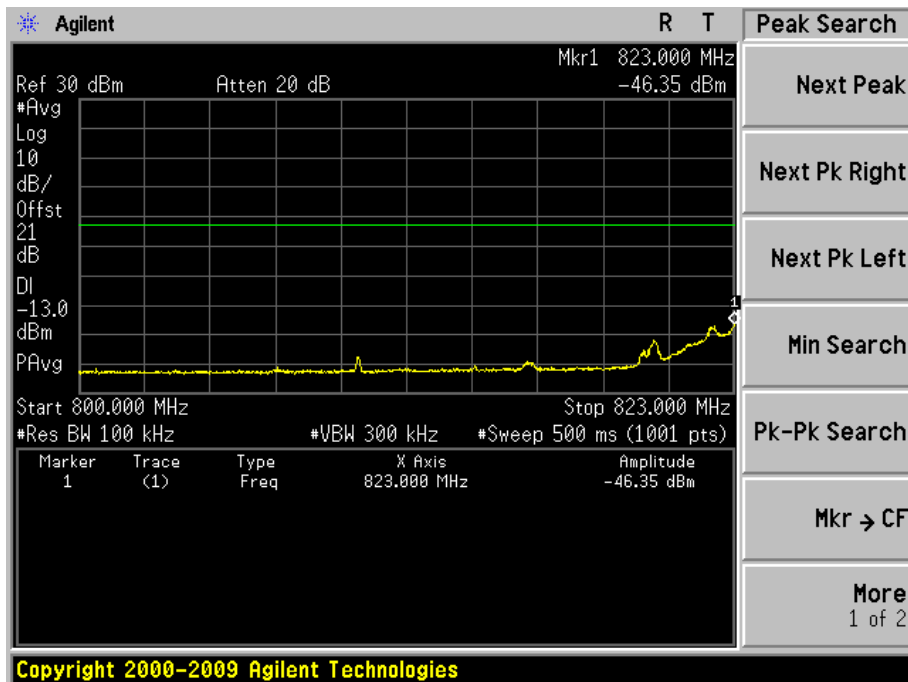
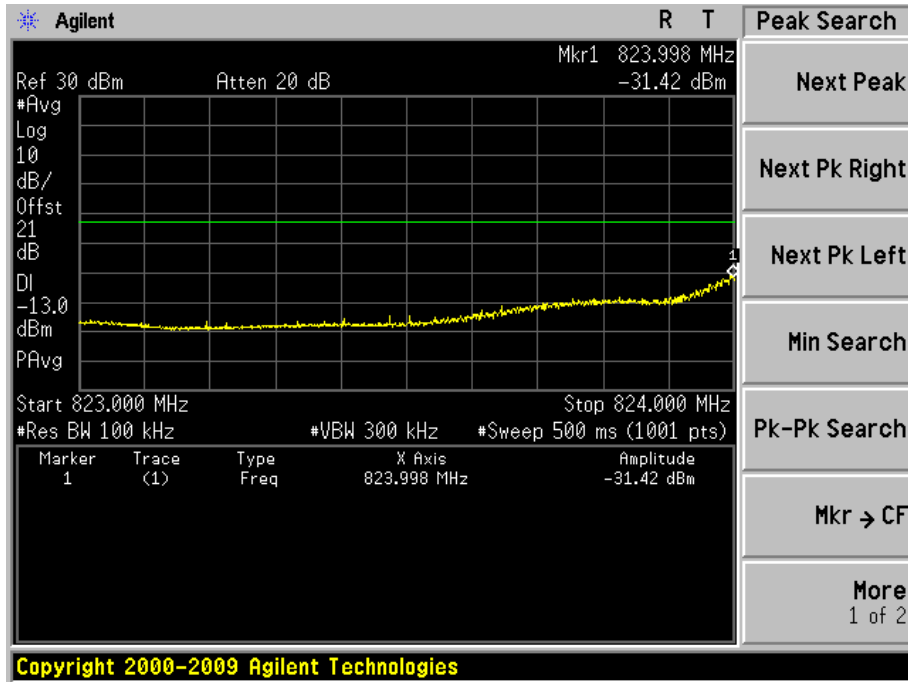
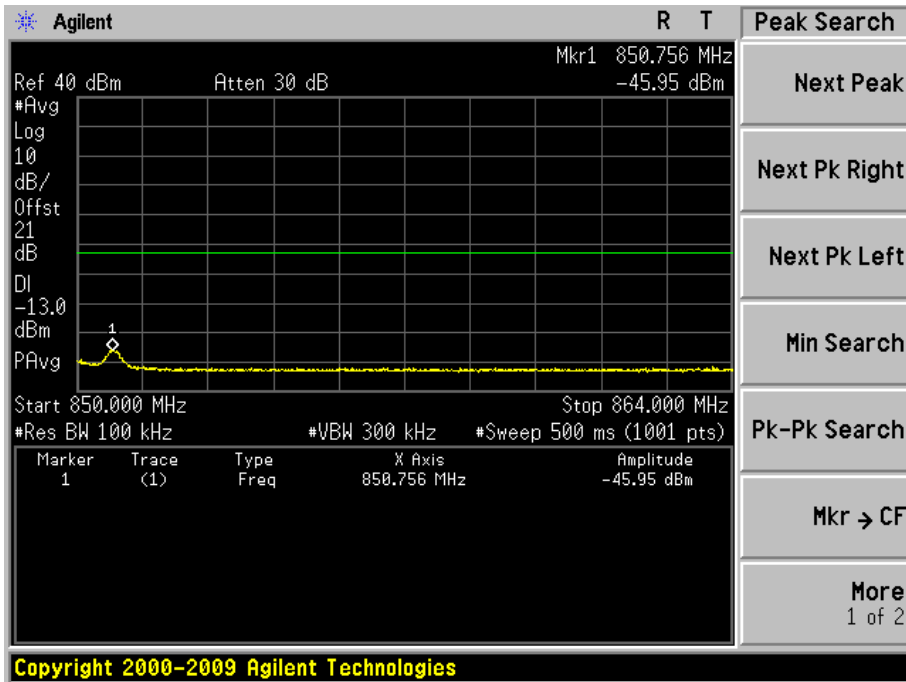
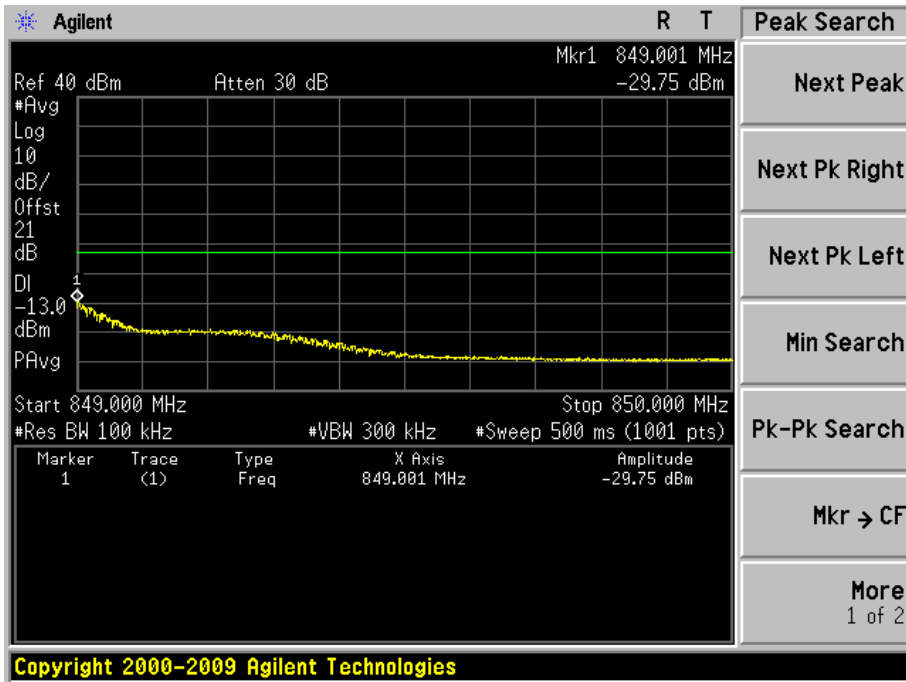
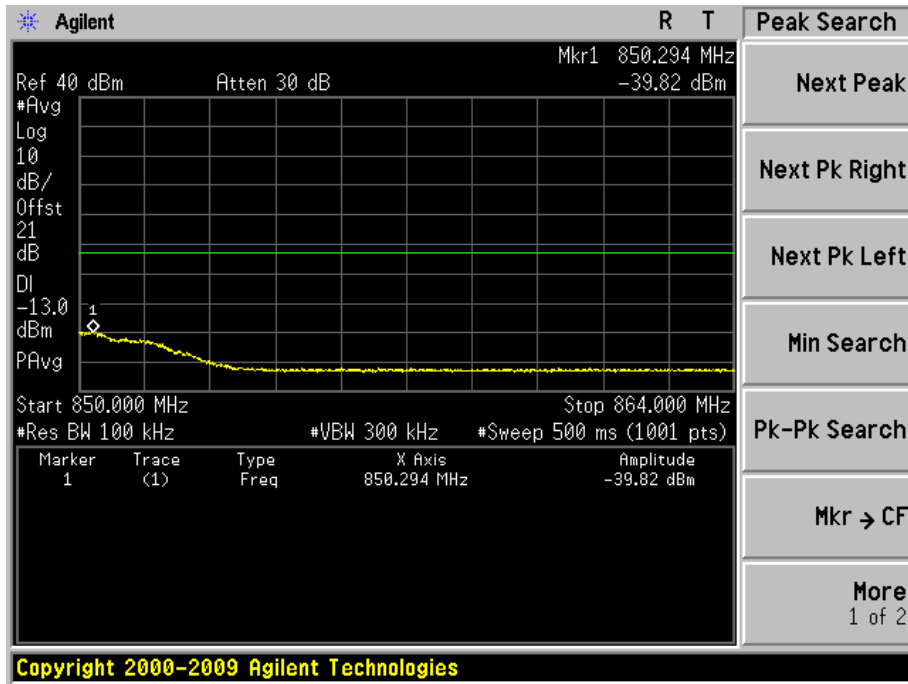
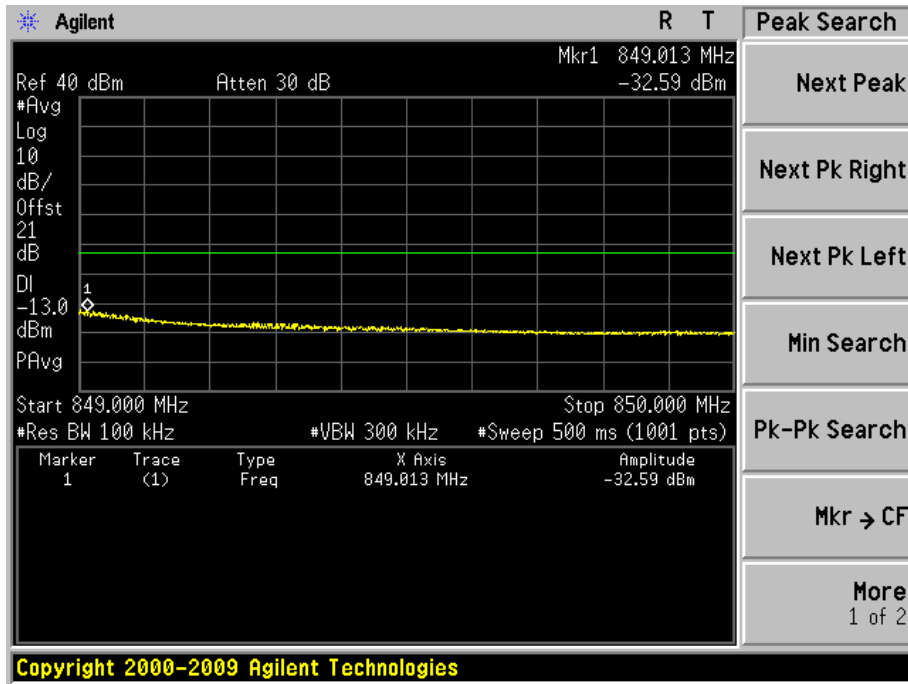

Figure Channel 26990 (844.00MHz)
1RB49



50RB0



Product	Wireless Module		
Test Item	Conducted Band Edge		
Test Mode	Mode 1: LTE Band 26 (10M/16QAM)		
Date of Test	2015/07/09	Test Site	AC6

Figure Channel 26840 (829.00MHz)

1RB0

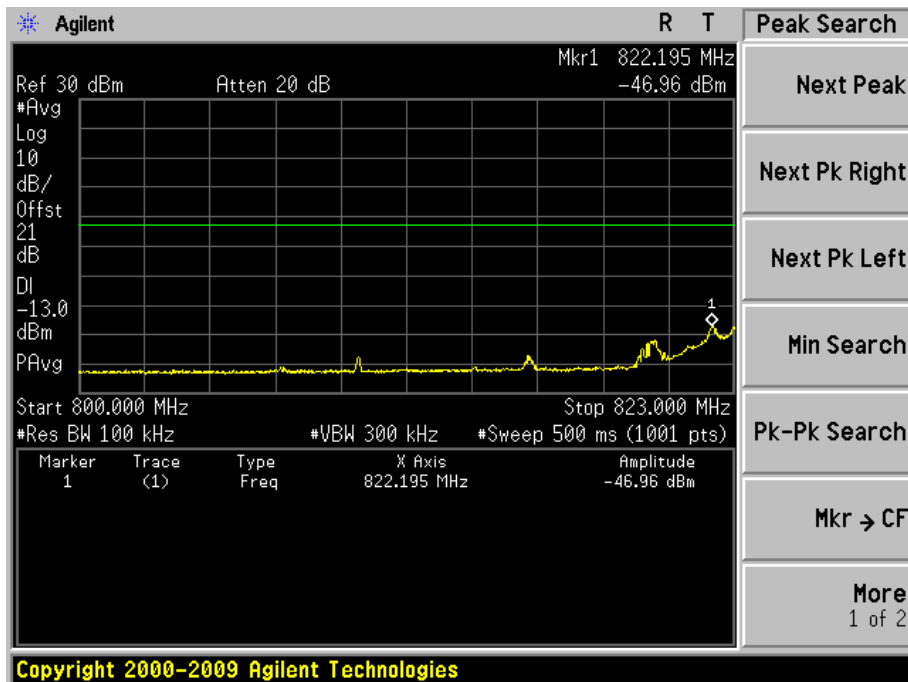
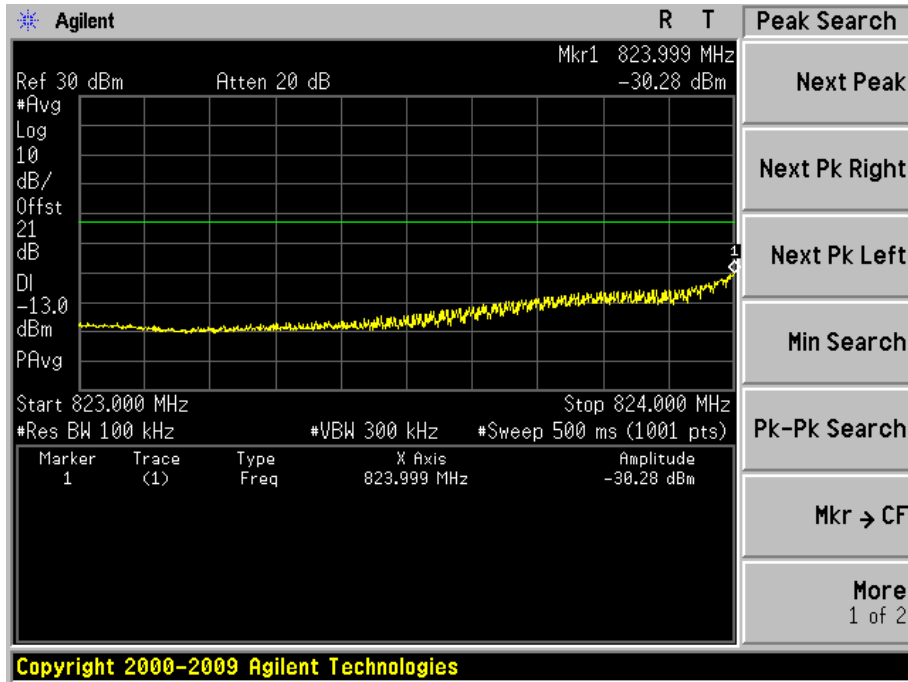

50RB0

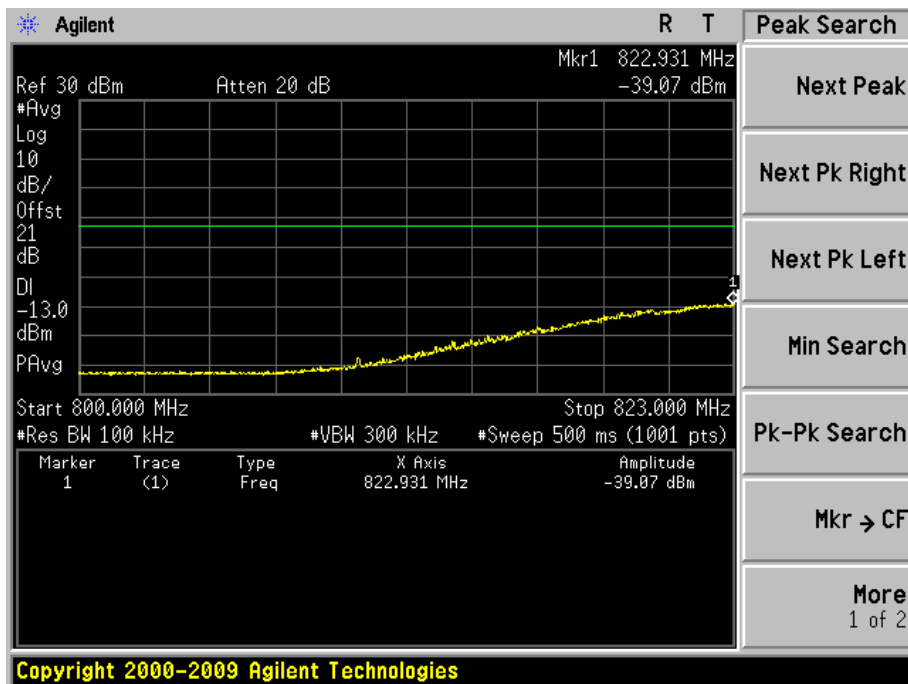
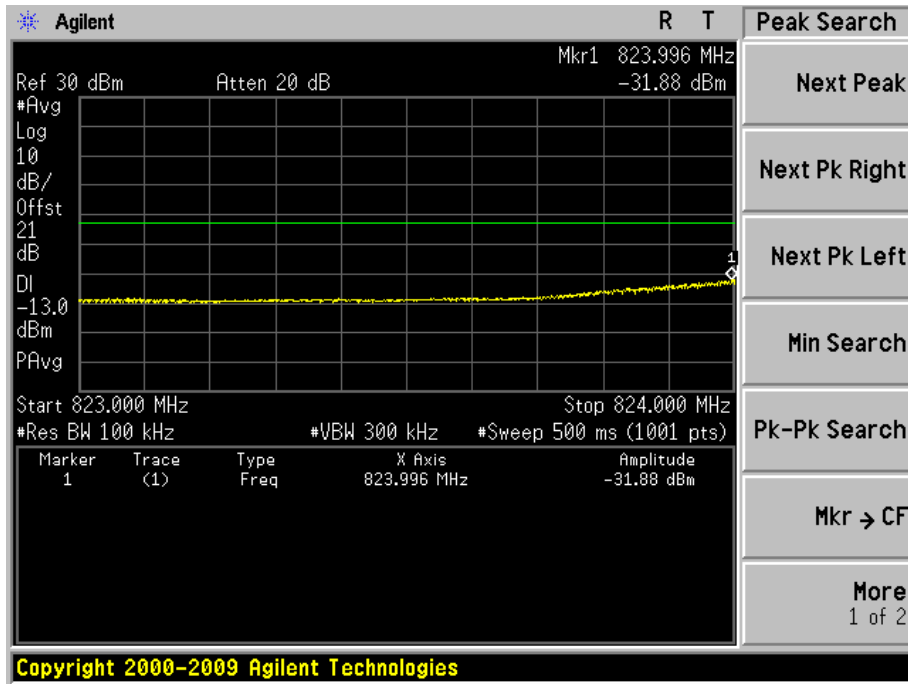
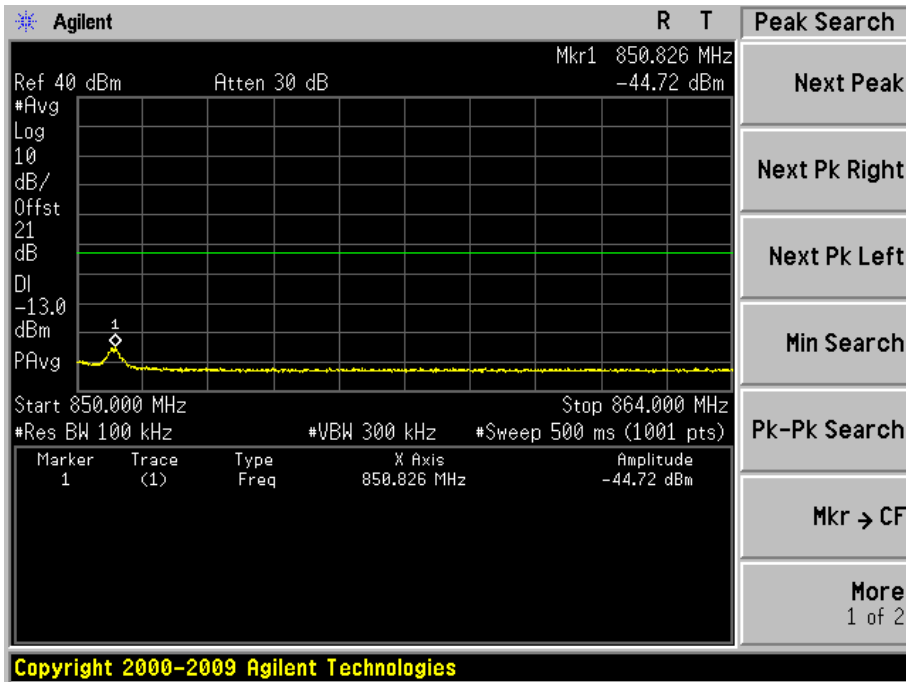
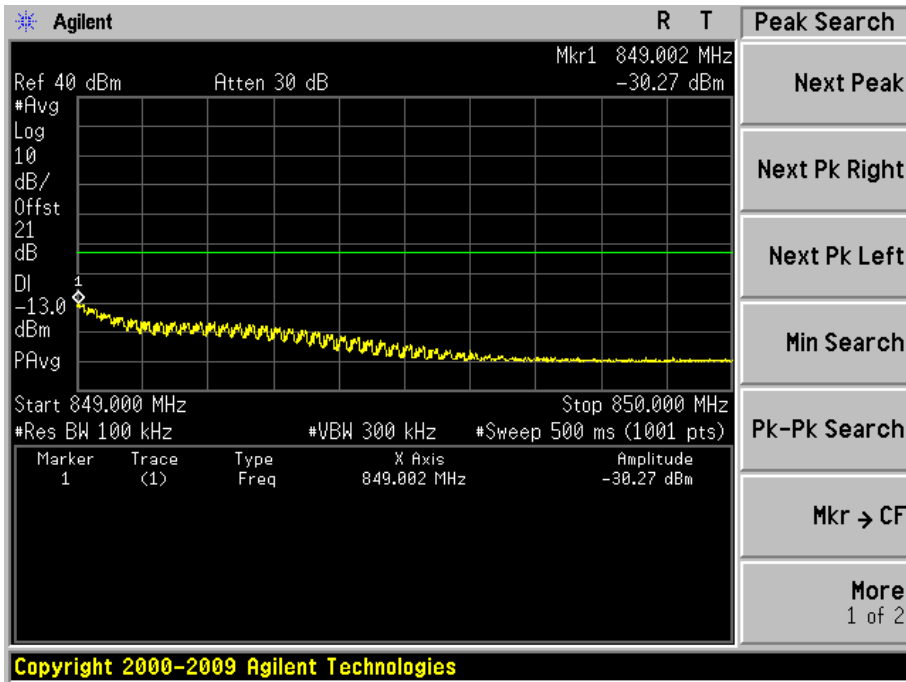
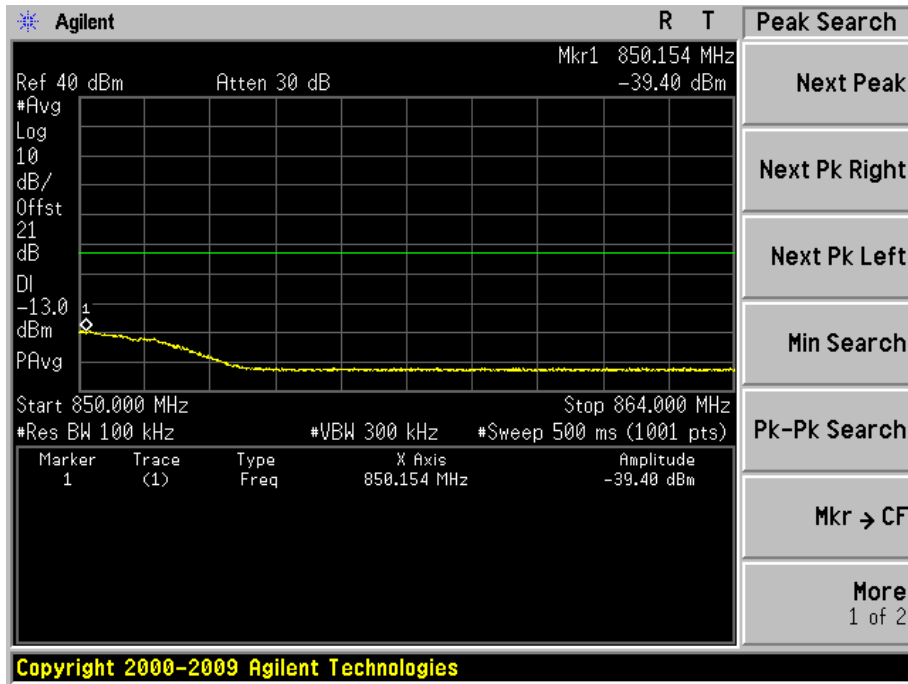
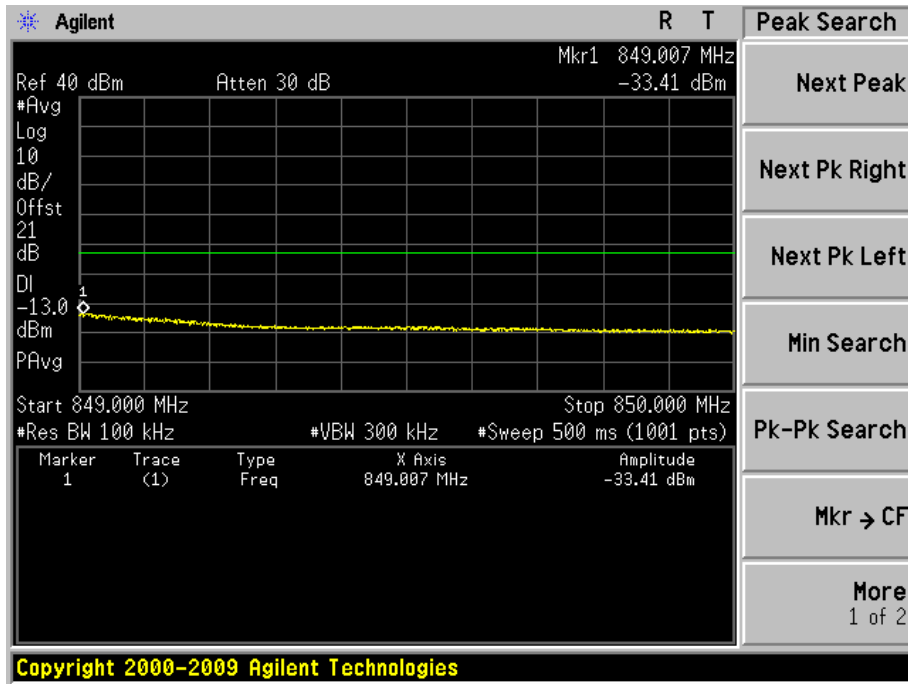

Figure Channel 26990 (844.00MHz)
1RB49



50RB0



Product	Wireless Module		
Test Item	Conducted Band Edge		
Test Mode	Mode 1: LTE Band 26 (5M/QPSK)		
Date of Test	2015/07/09	Test Site	AC6

Figure Channel 26815 (826.5MHz)

1RB0

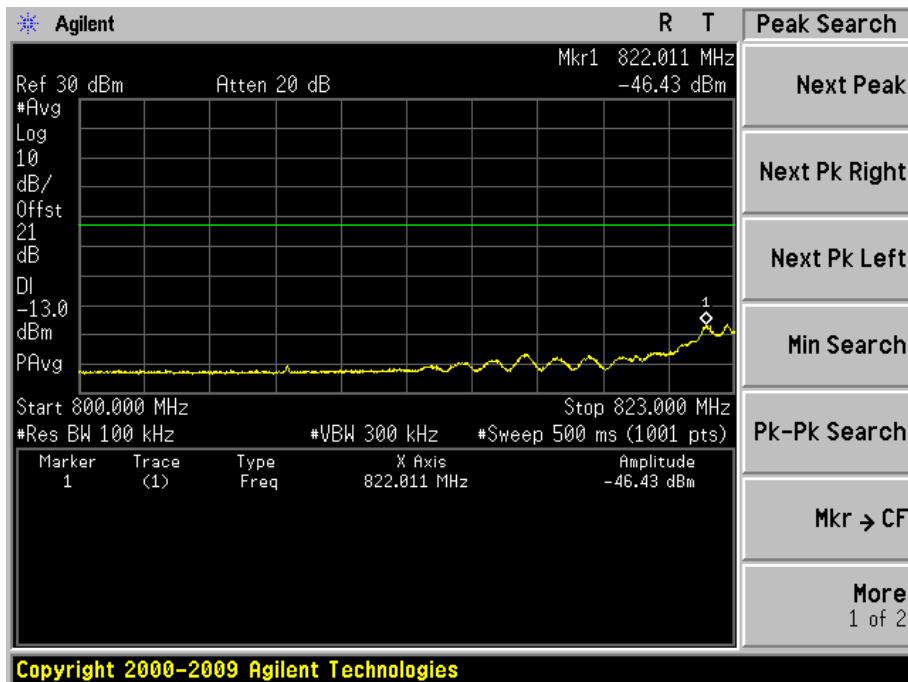
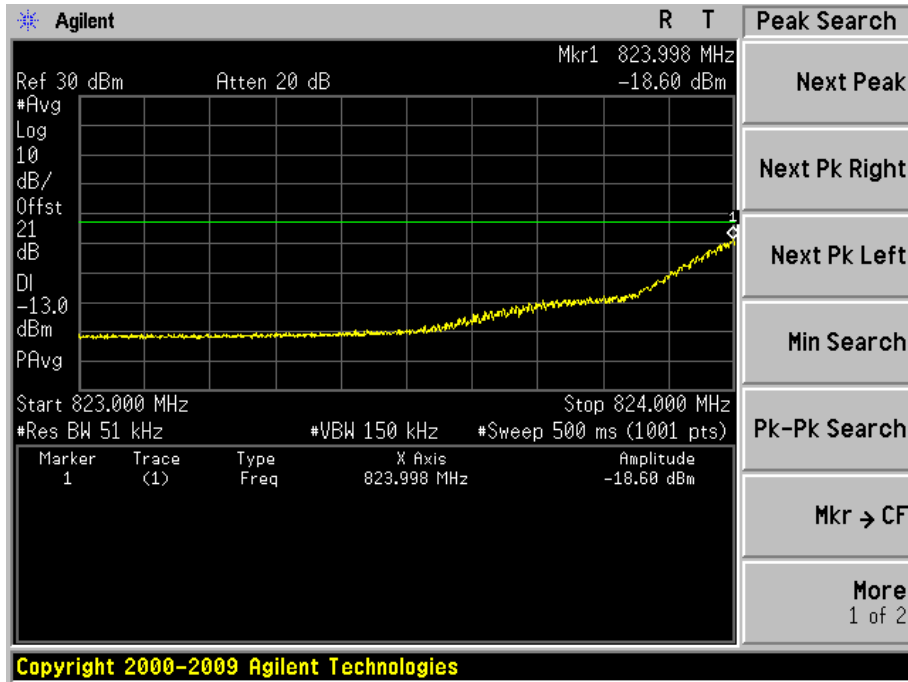

25RB0

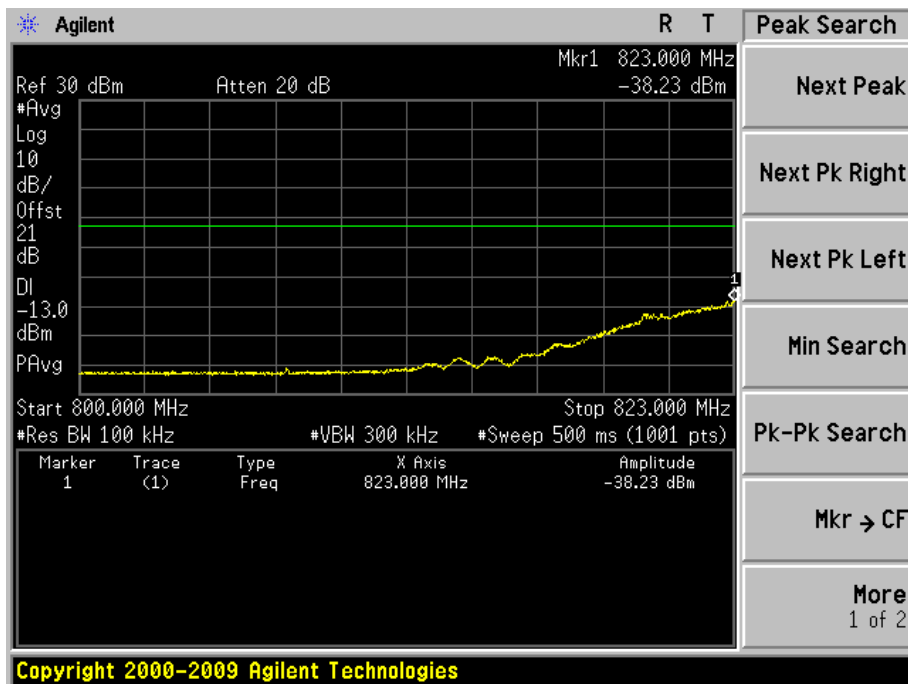
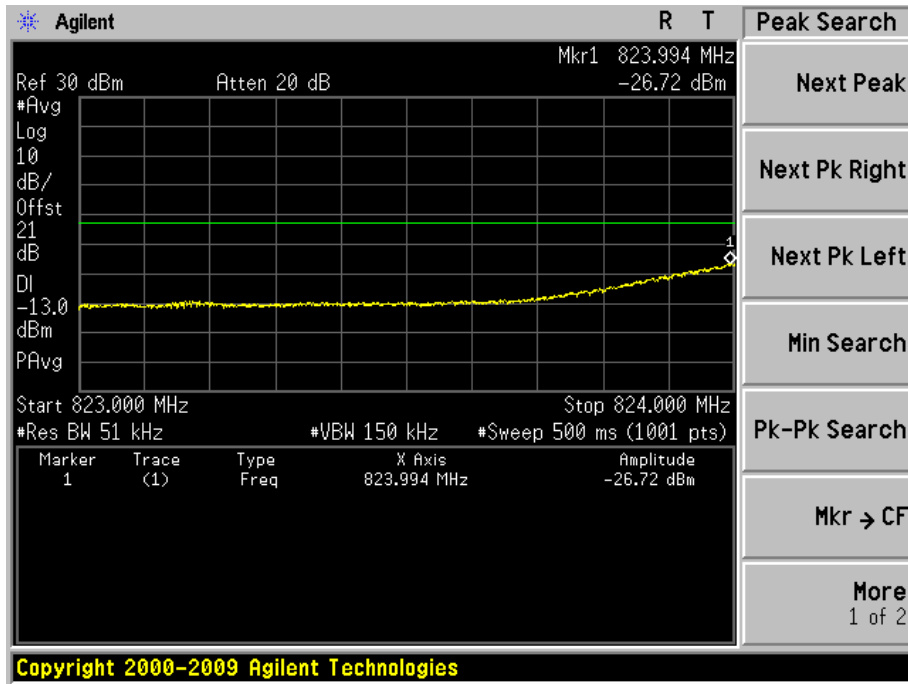
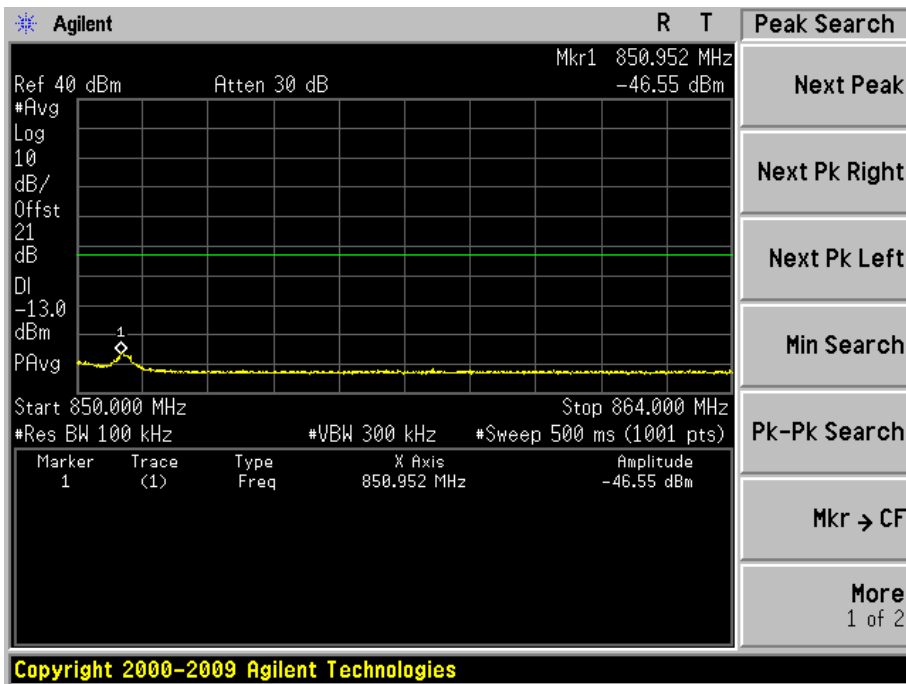
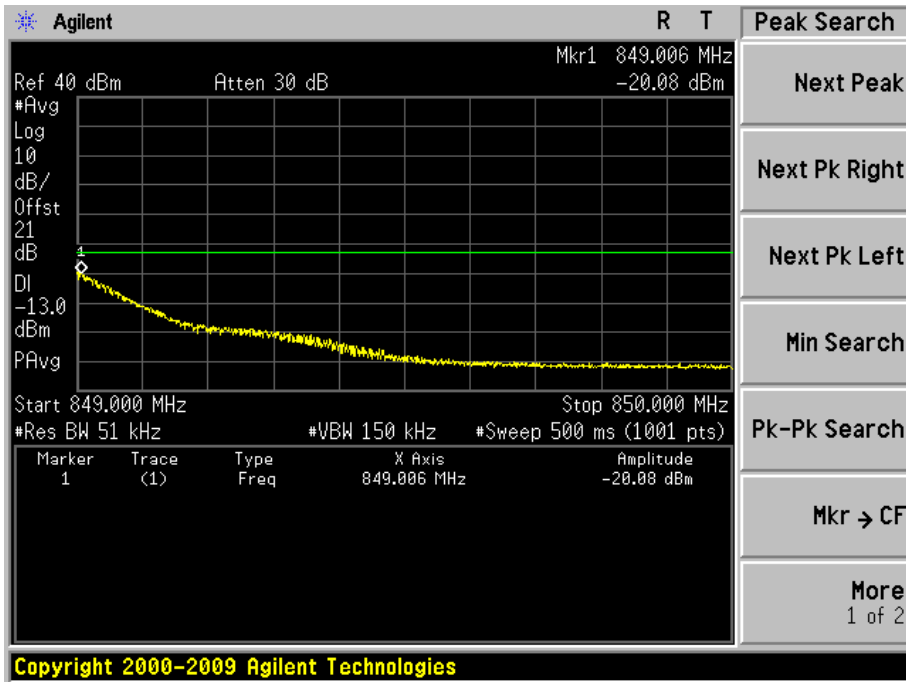
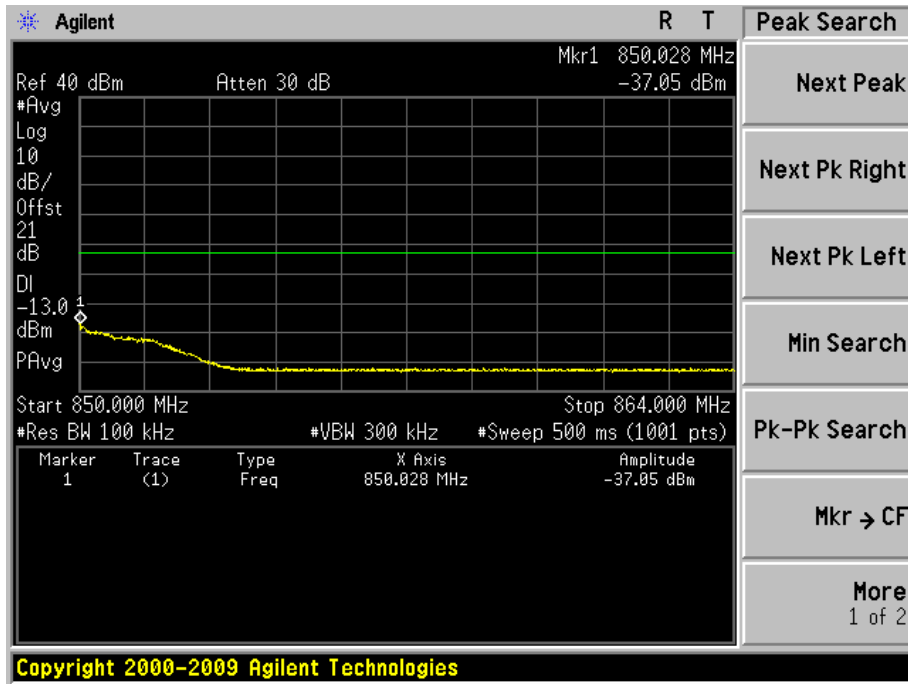
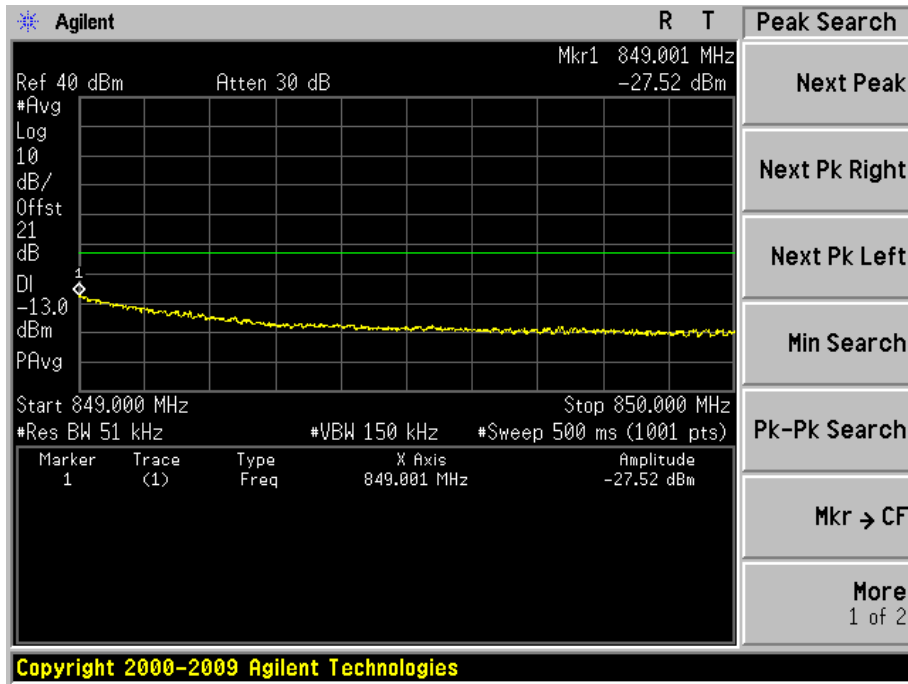

Figure Channel 27015 (846.50MHz)
1RB24



25RB0



Product	Wireless Module		
Test Item	Conducted Band Edge		
Test Mode	Mode 1: LTE Band 26 (5M/16QAM)		
Date of Test	2015/07/09	Test Site	AC6

Figure Channel 26815 (826.5MHz)

1RB0

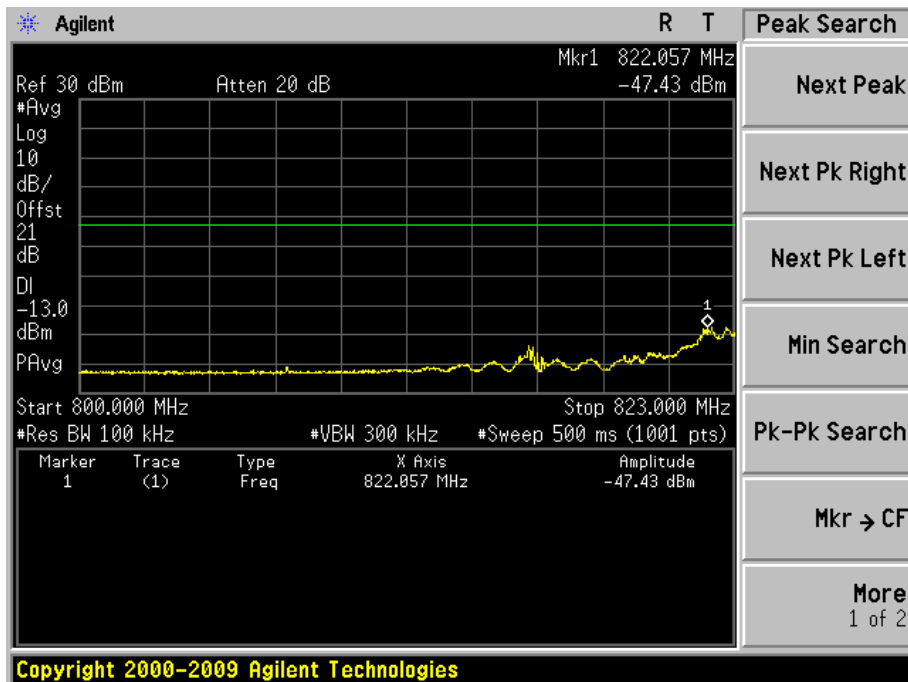
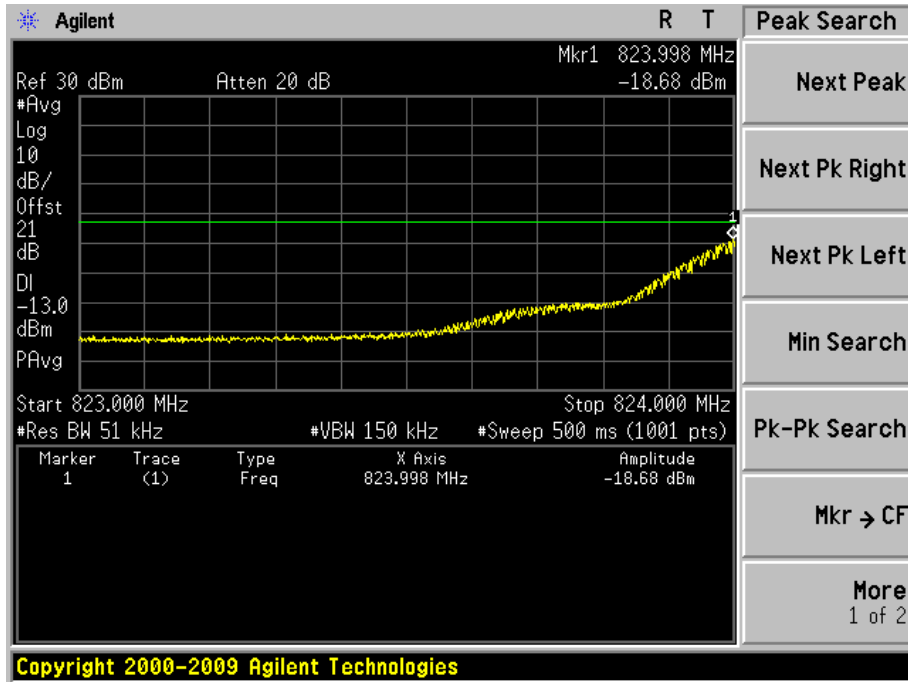

25RB0

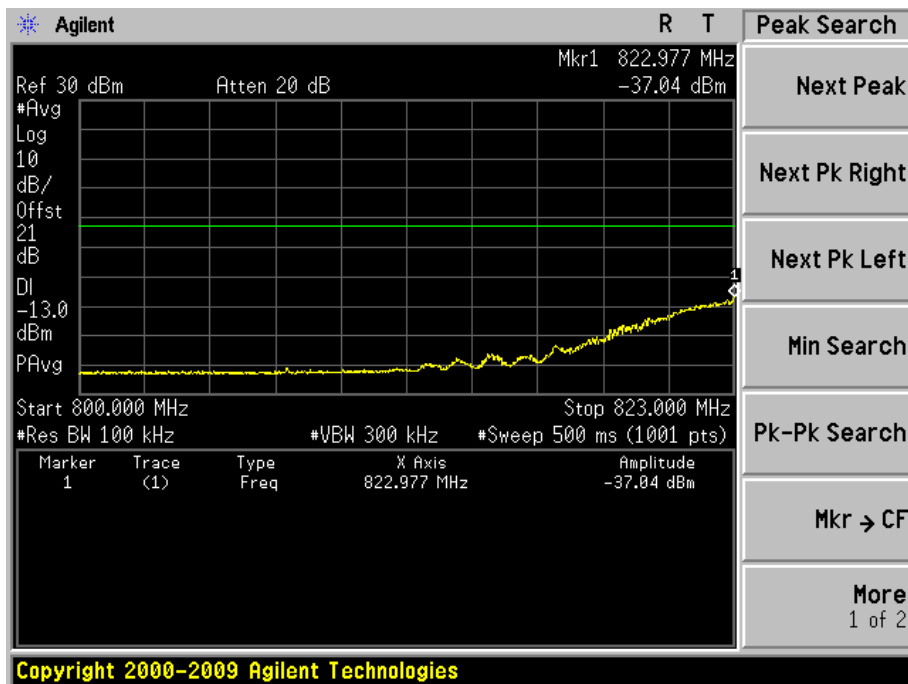
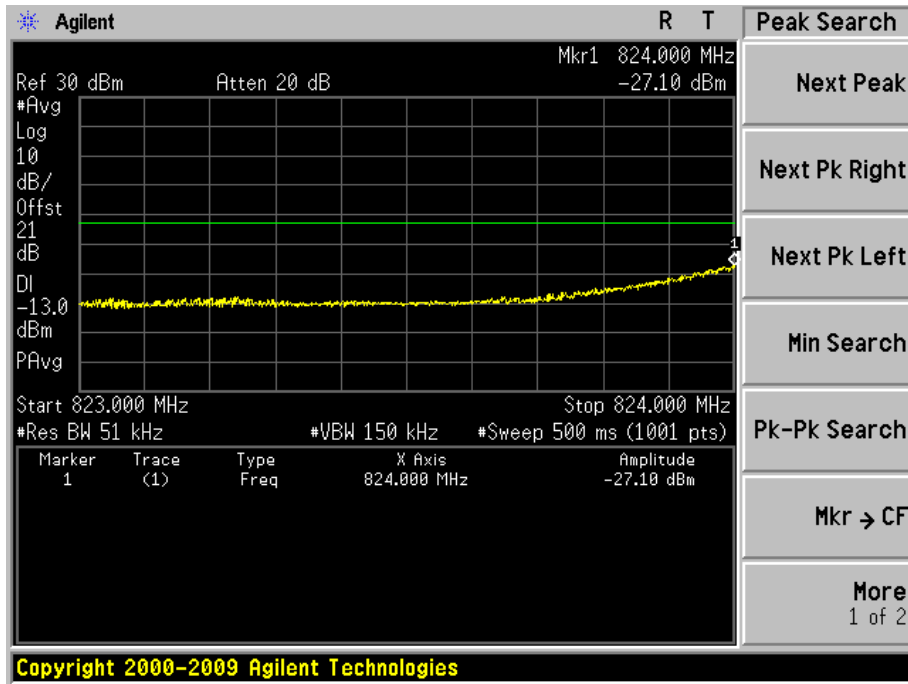
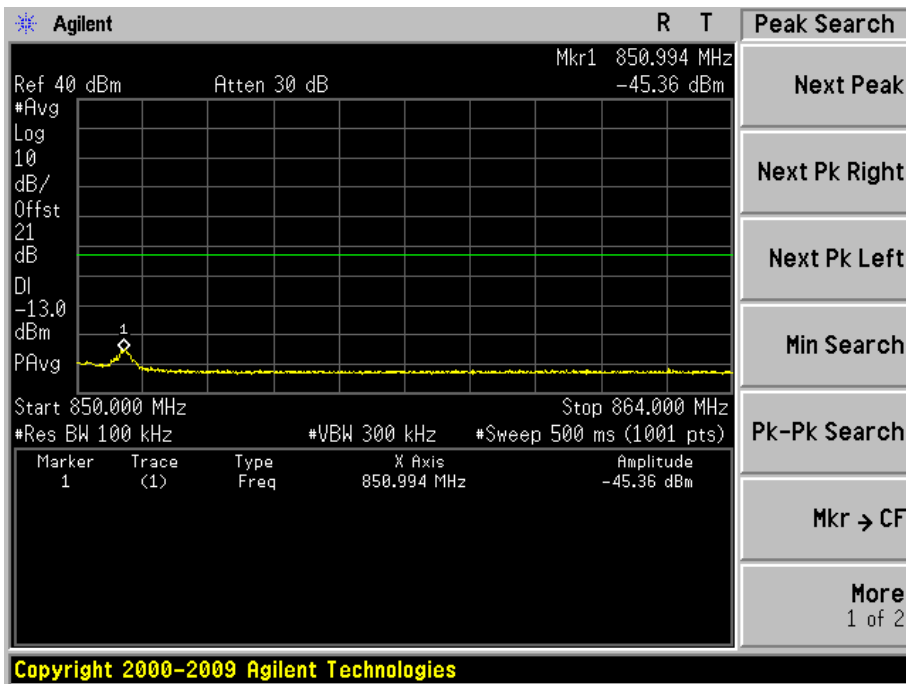
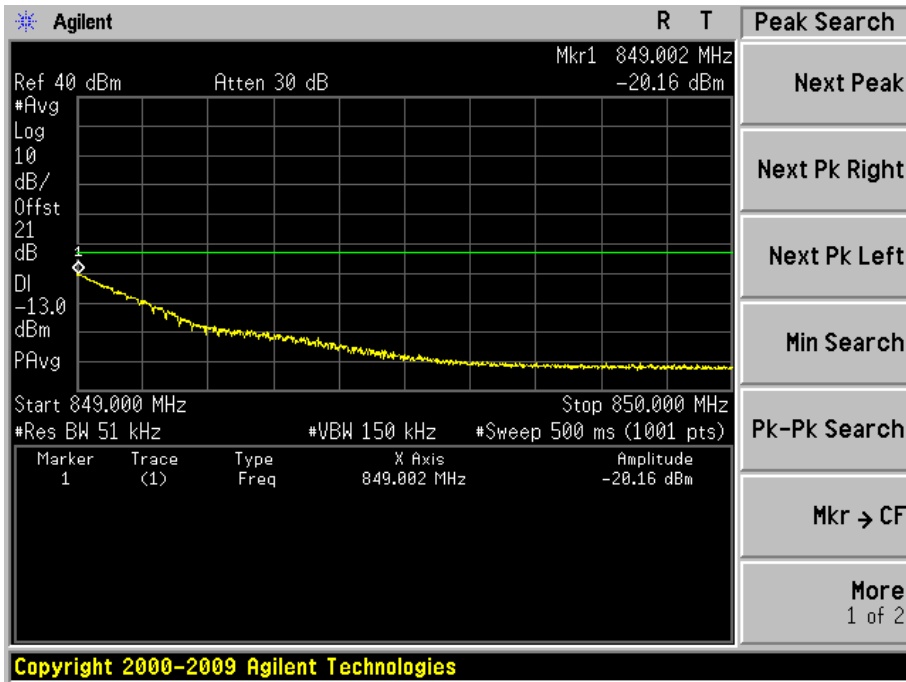
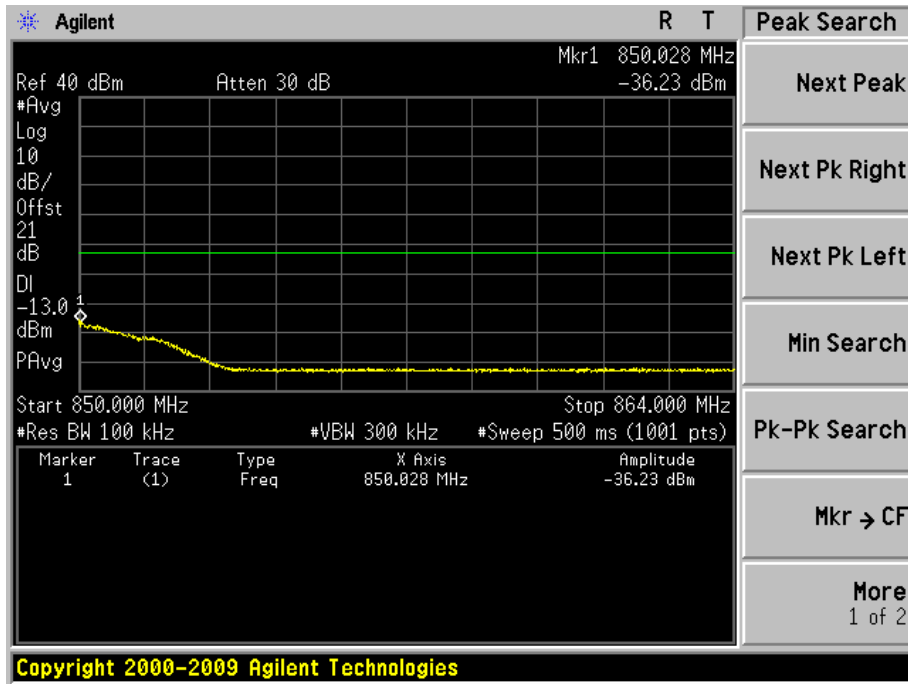
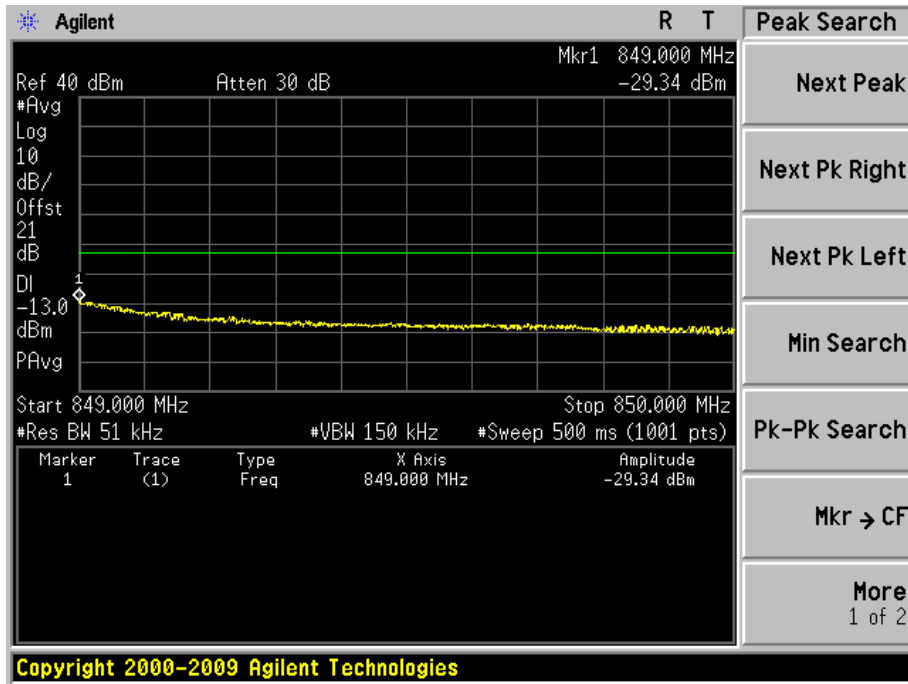

Figure Channel 27015 (846.50MHz)
1RB24



25RB0



Product	Wireless Module		
Test Item	Conducted Band Edge		
Test Mode	Mode 1: LTE Band 26 (3M/QPSK)		
Date of Test	2015/07/09	Test Site	AC6

Figure Channel 26805 (825.50MHz)

1RB0

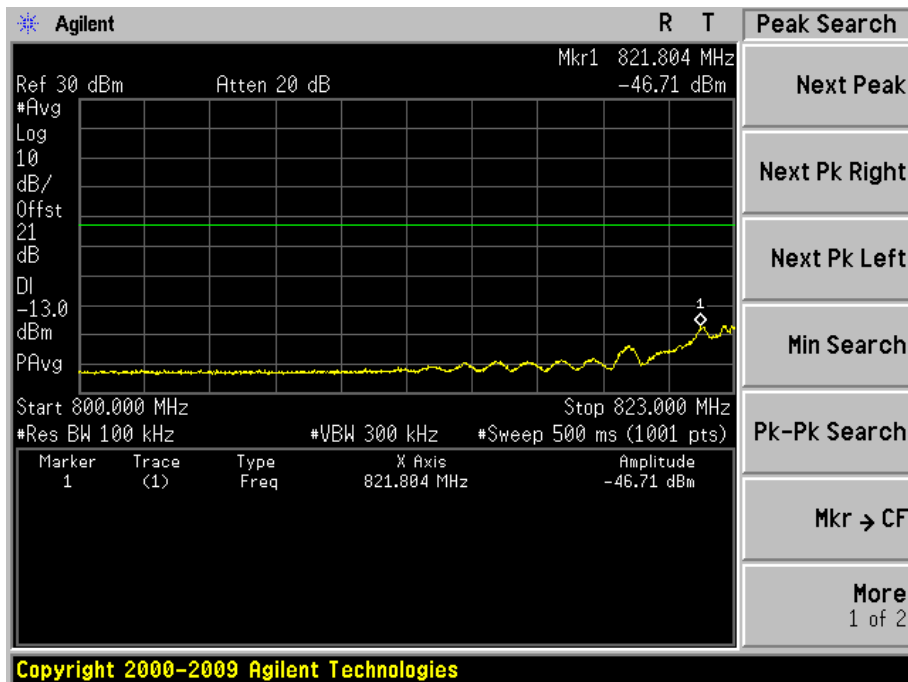
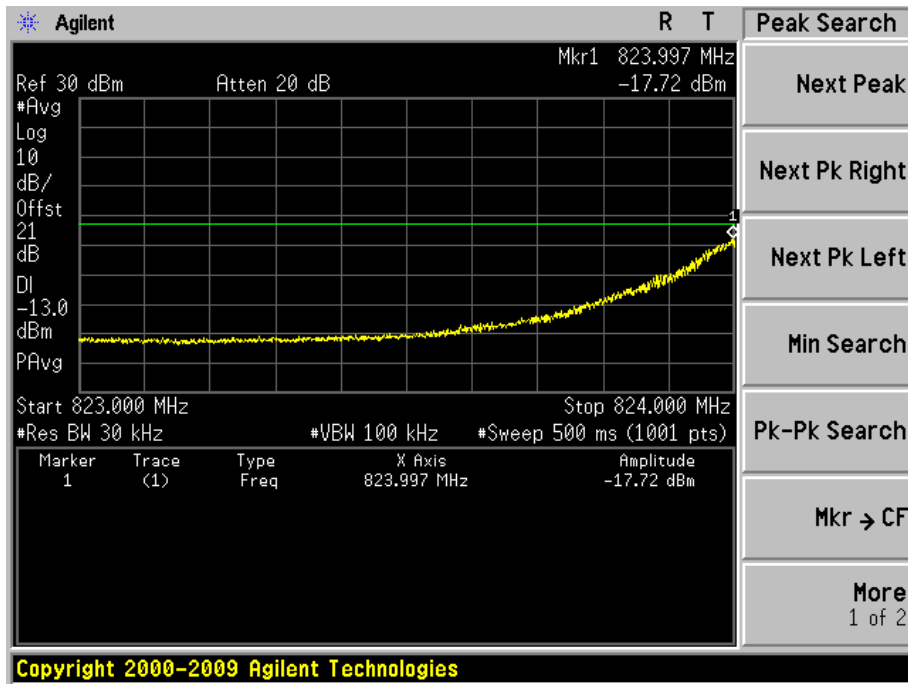

15RB0

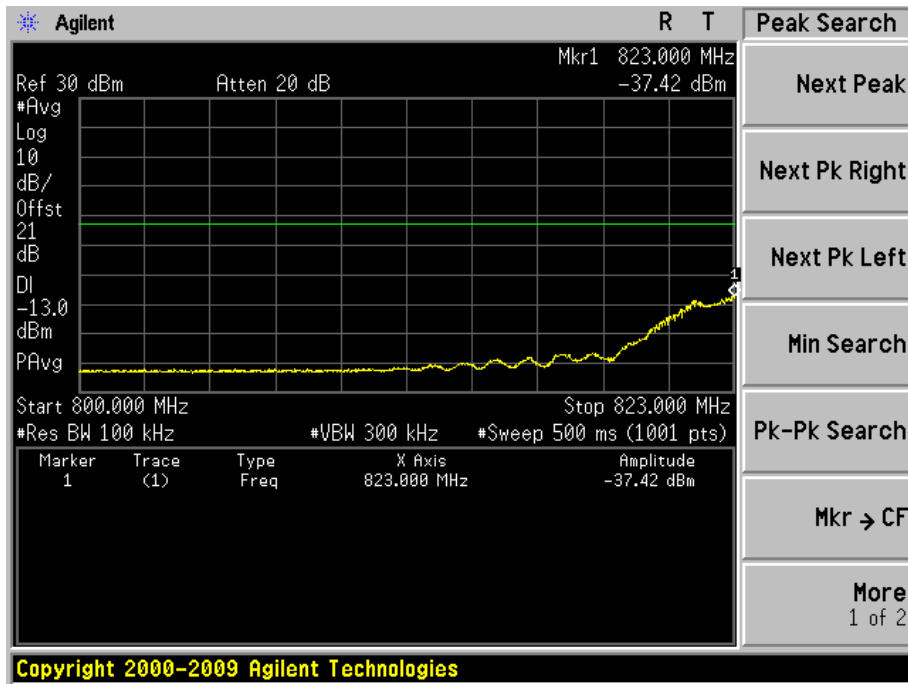
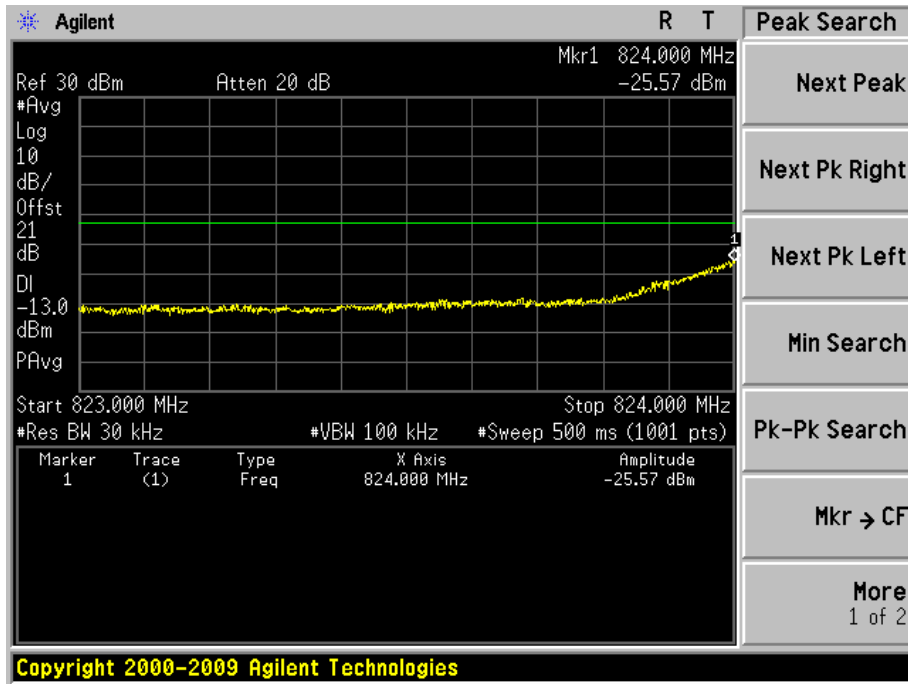
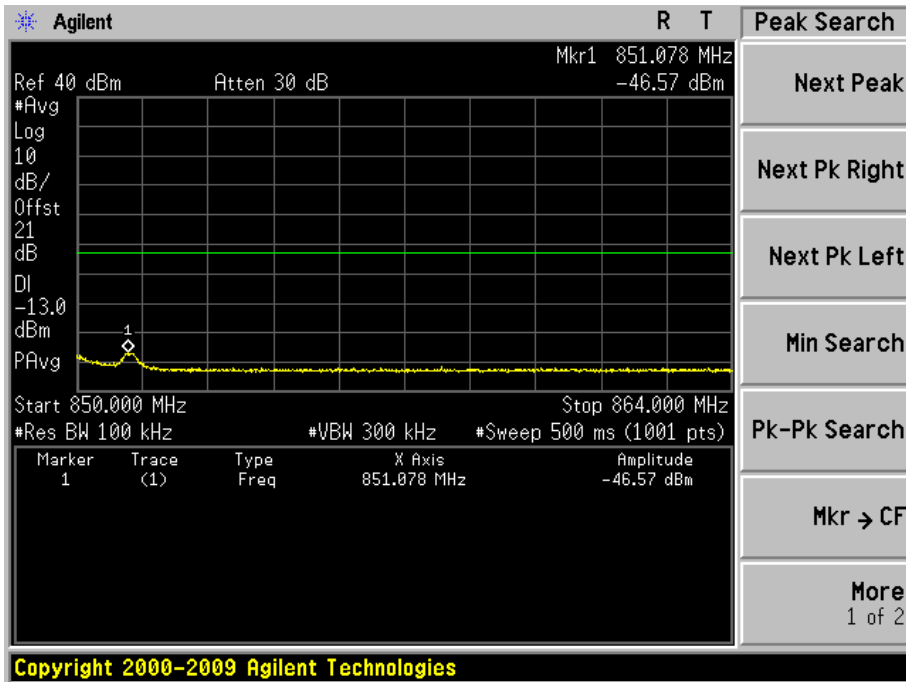
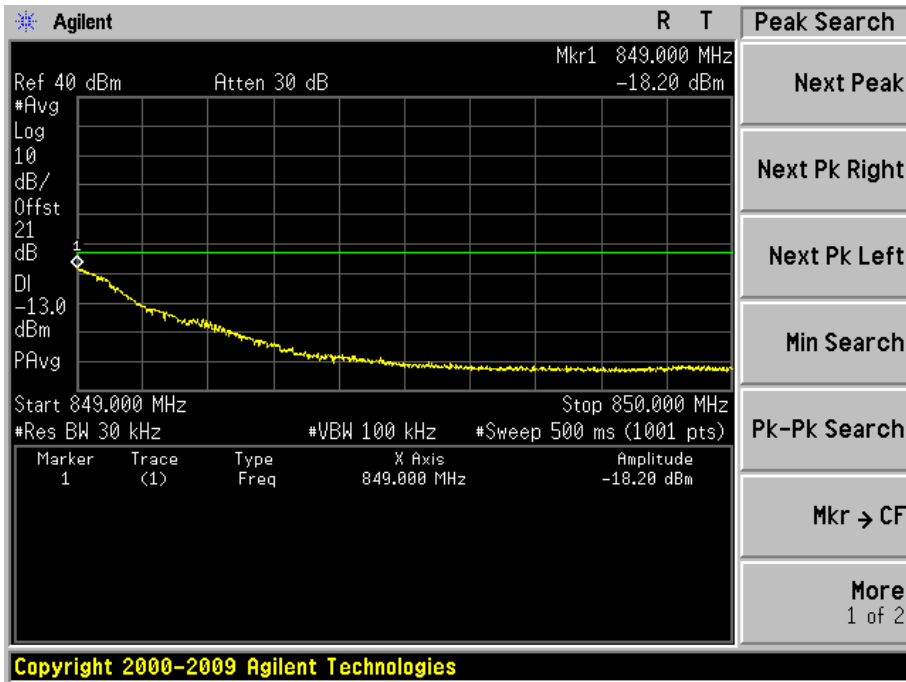
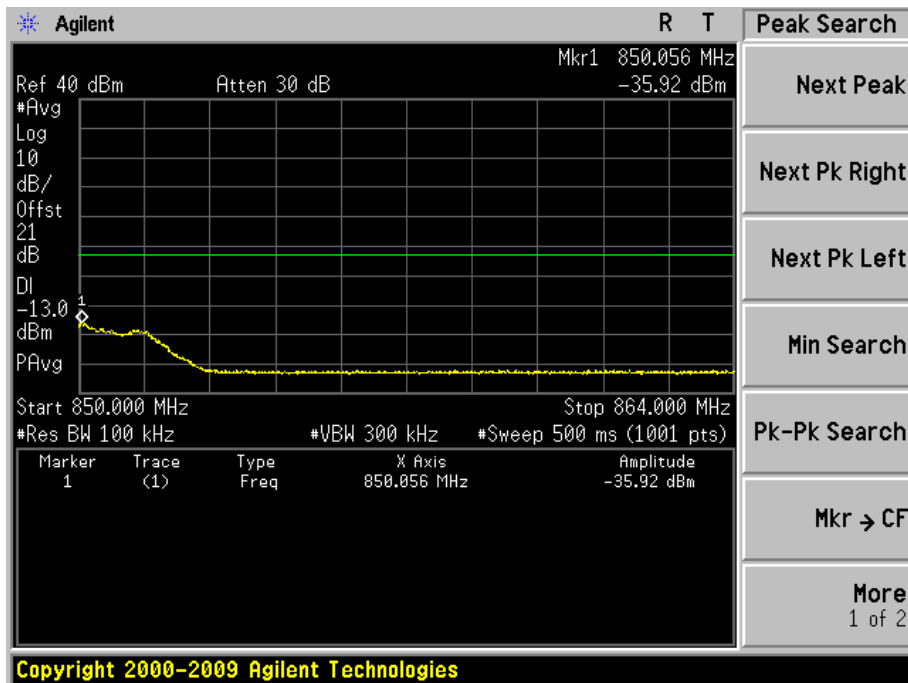
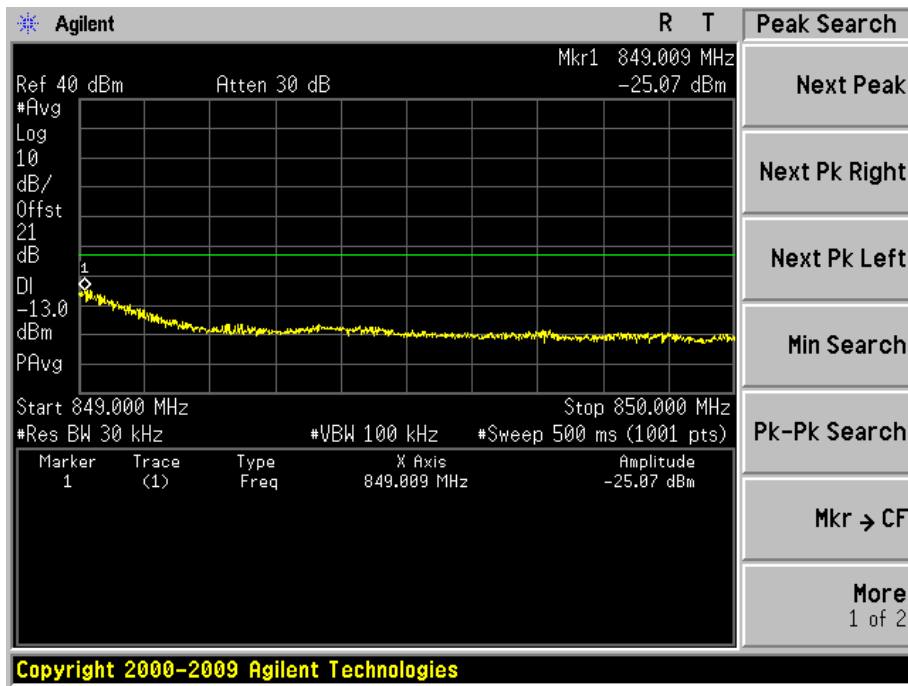

Figure Channel 27025 (847.50MHz)

1RB14



15RB0



Product	Wireless Module		
Test Item	Conducted Band Edge		
Test Mode	Mode 1: LTE Band 26 (3M/16QAM)		
Date of Test	2015/07/09	Test Site	AC6

Figure Channel 26805 (825.50MHz)
1RB0

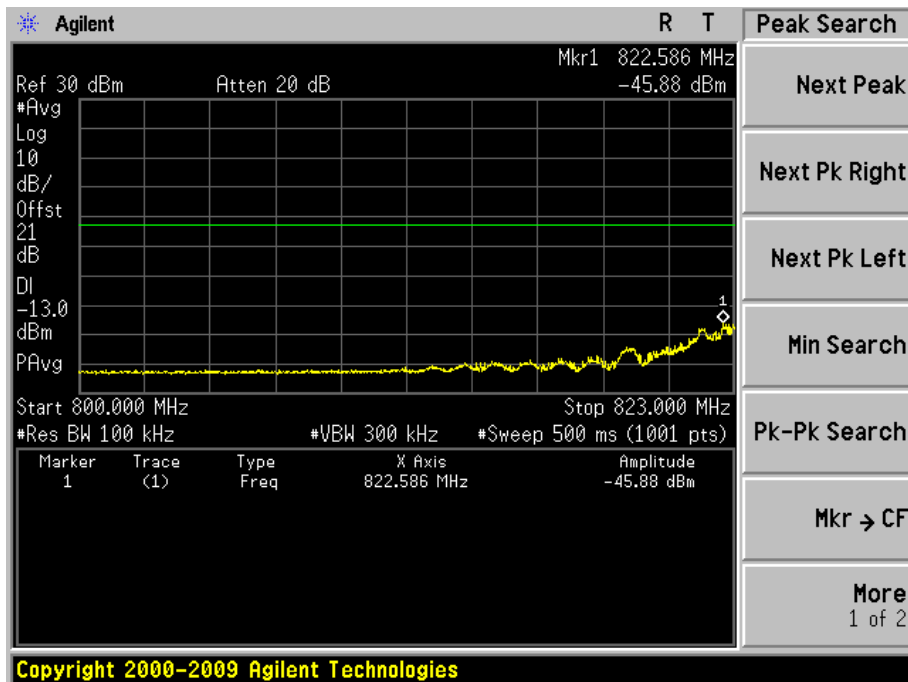
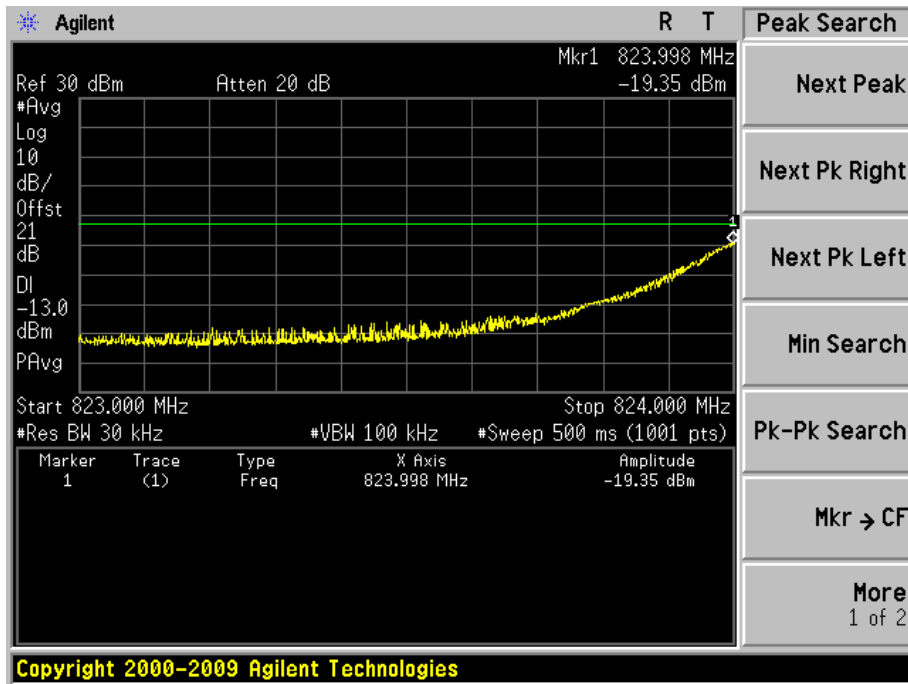

15RB0

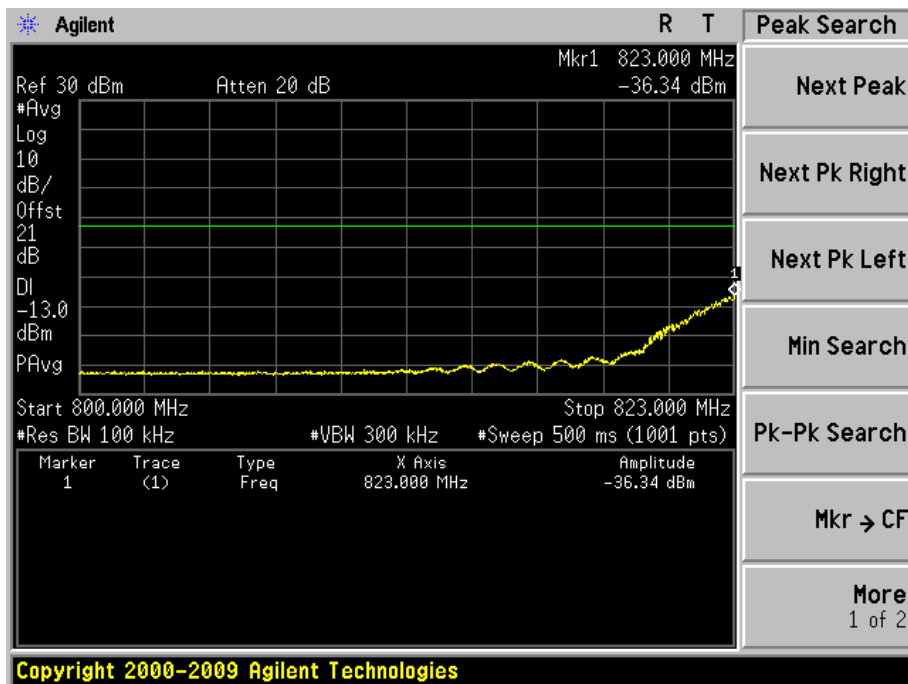
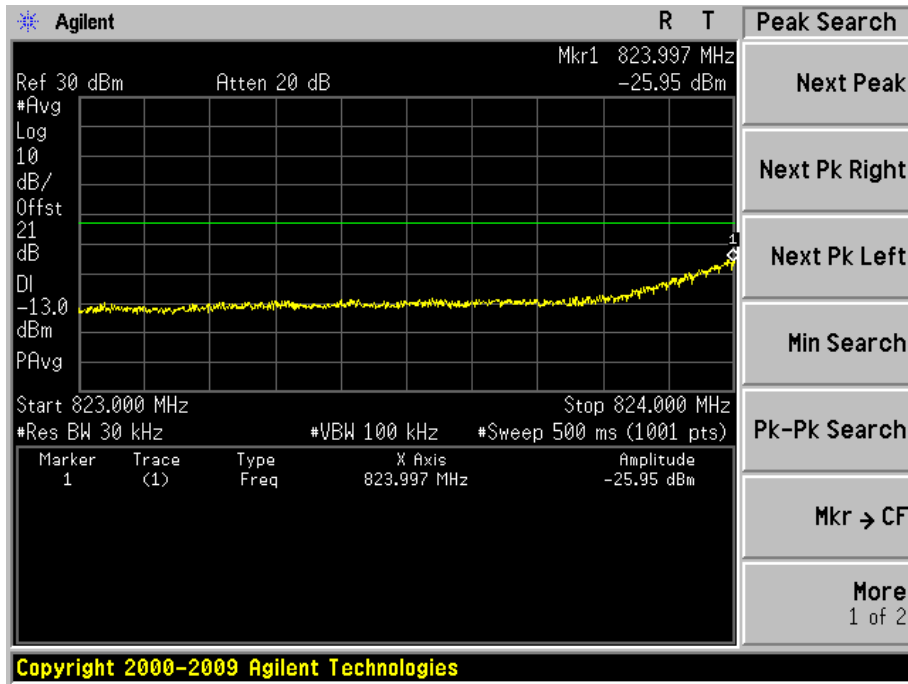
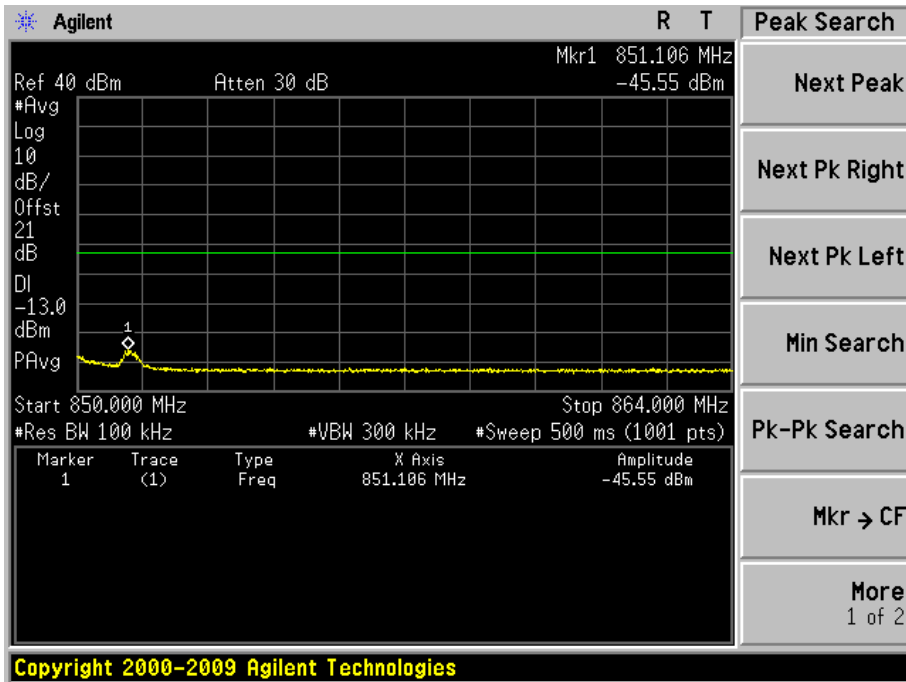
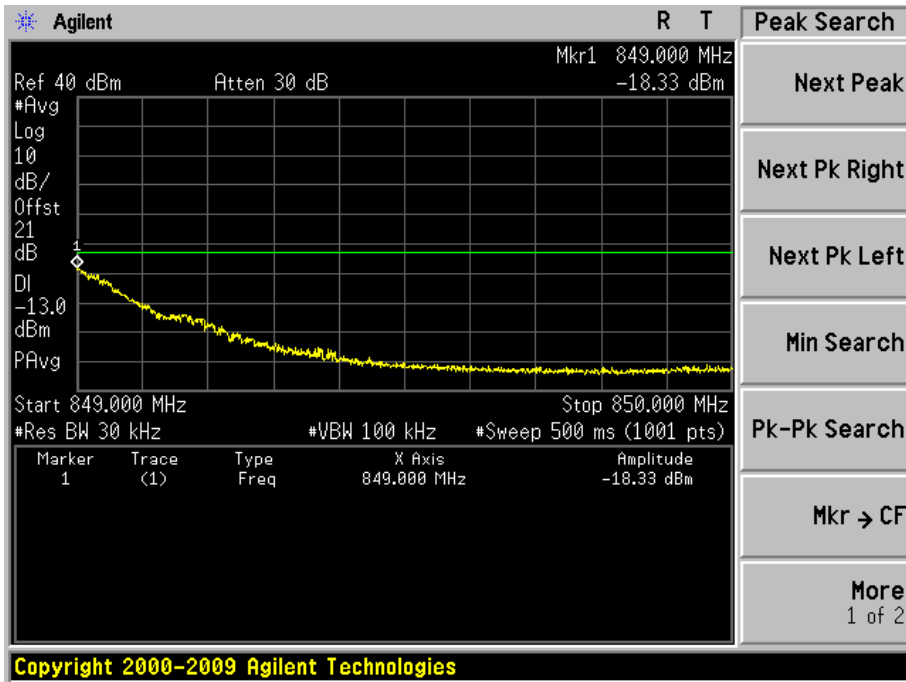
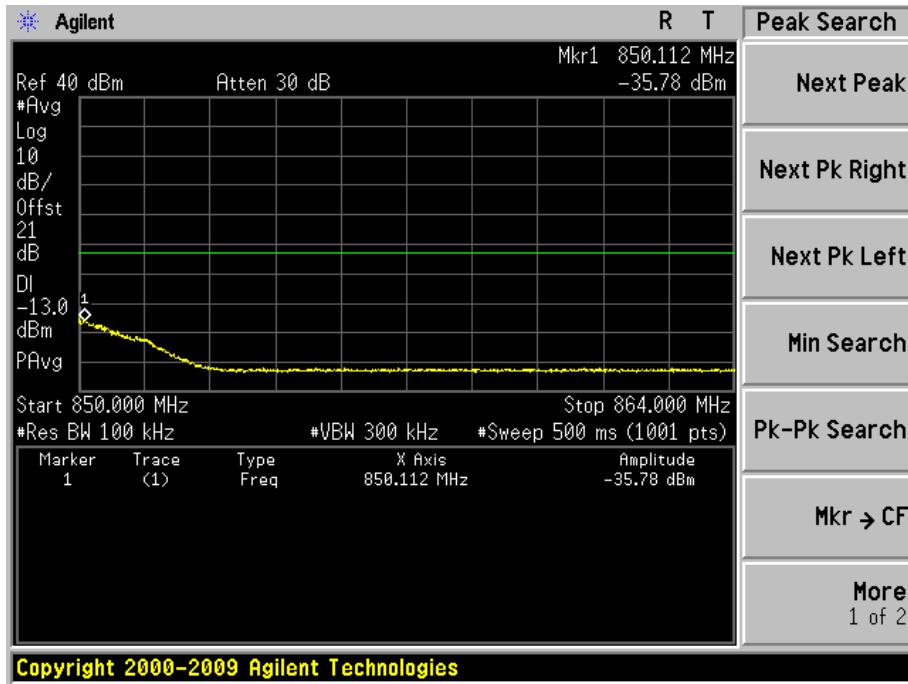
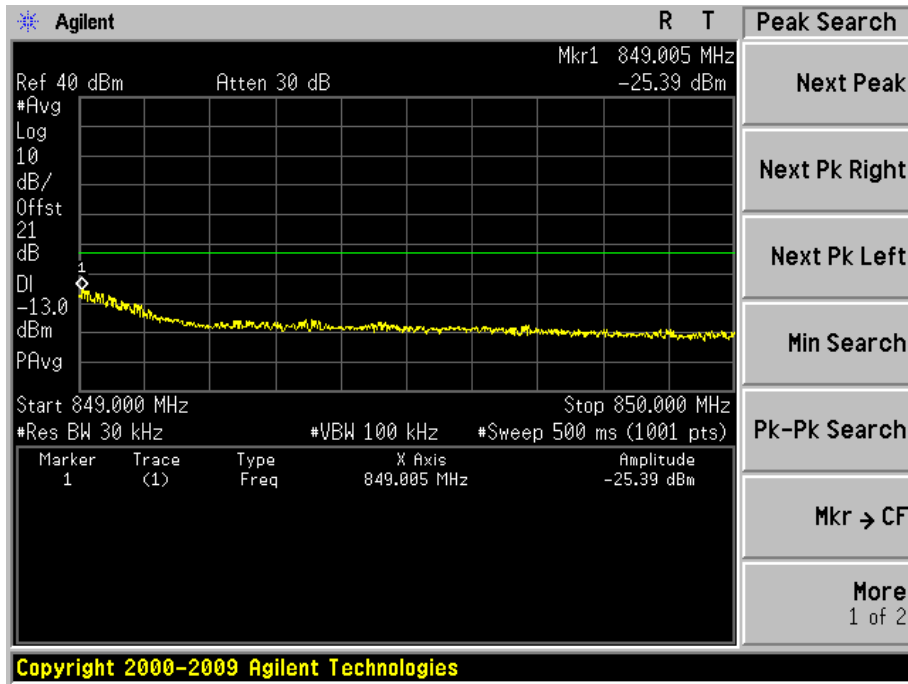

Figure Channel 26805 (825.50MHz)

1RB14



15RB0



Product	Wireless Module		
Test Item	Conducted Band Edge		
Test Mode	Mode 1: LTE Band 26 (1.4M/QPSK)		
Date of Test	2015/07/09	Test Site	AC6

Figure Channel 26797 (824.70MHz)

1RB0

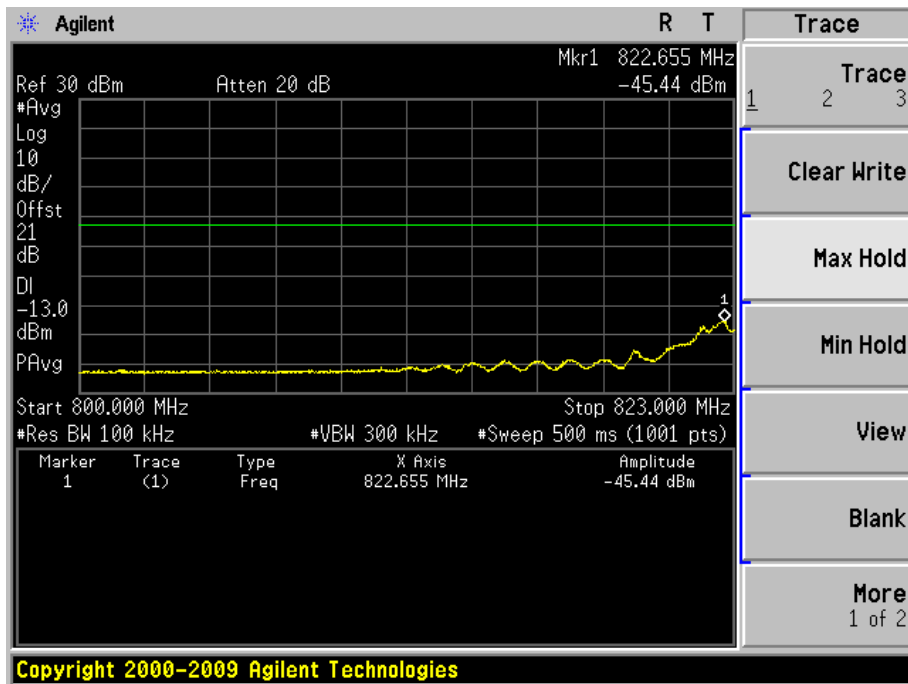
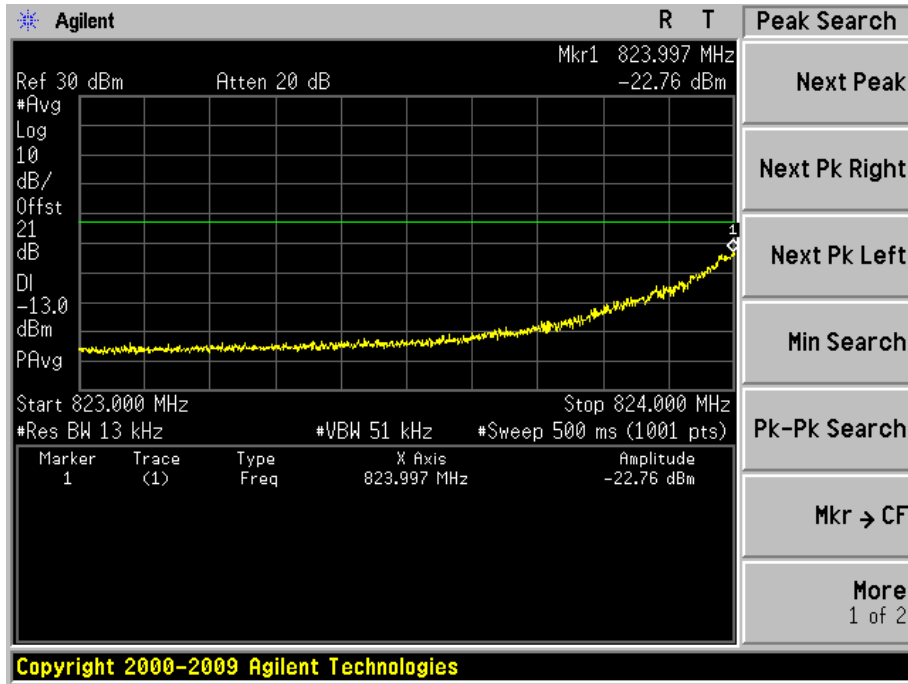

7RB0

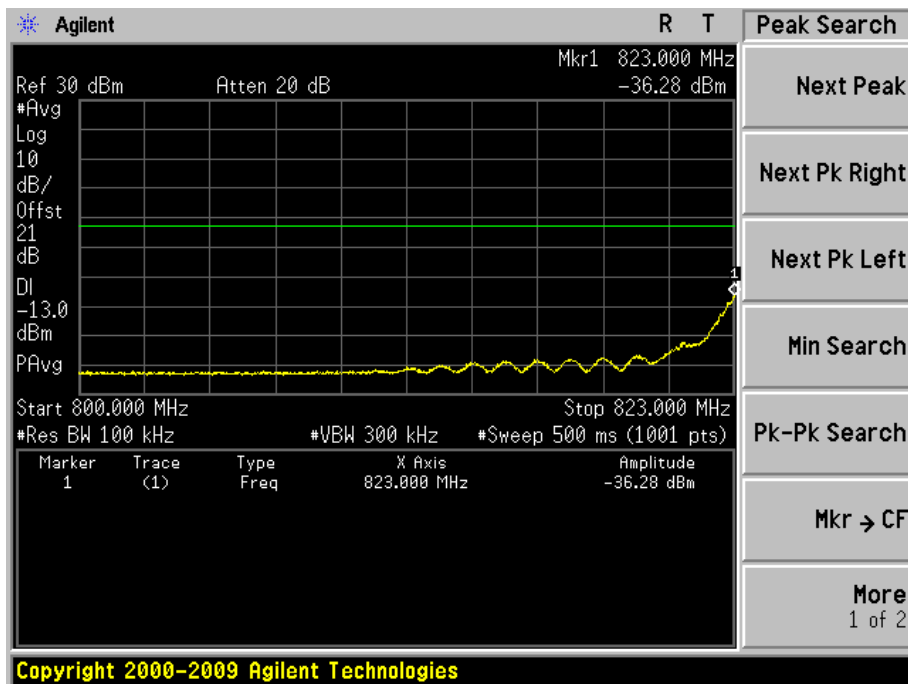
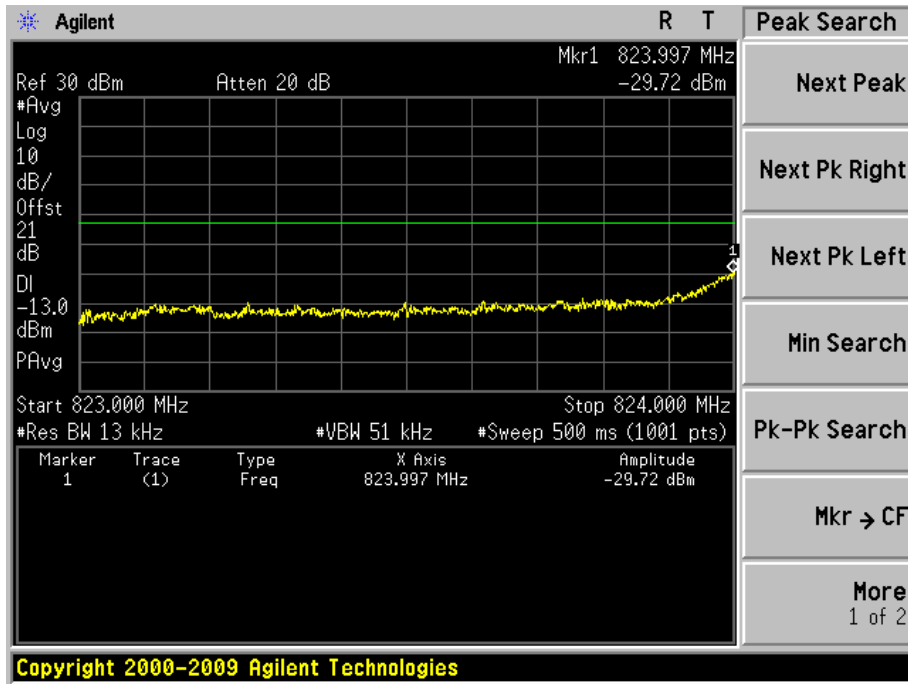
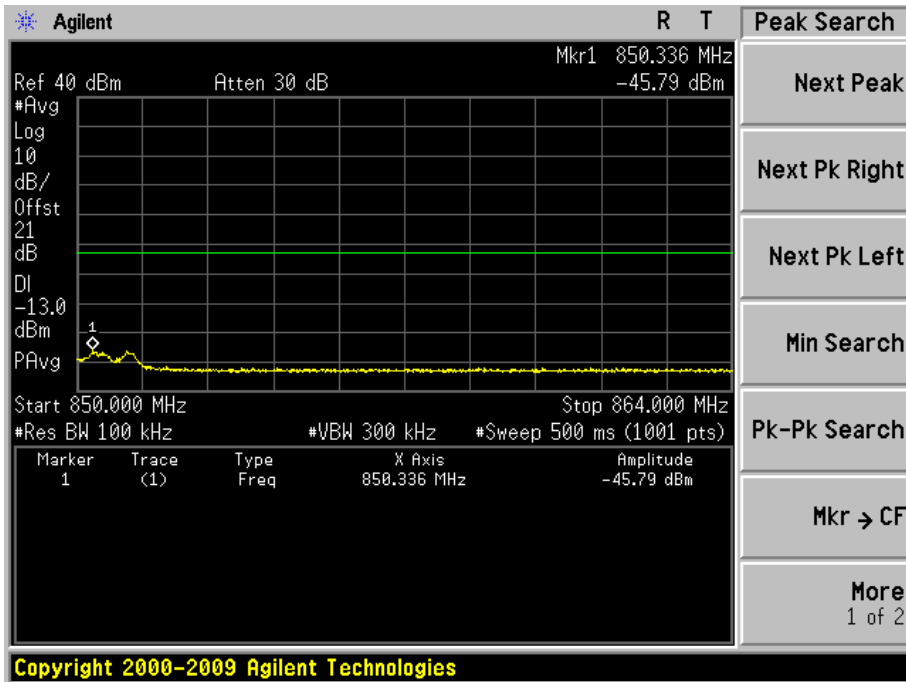
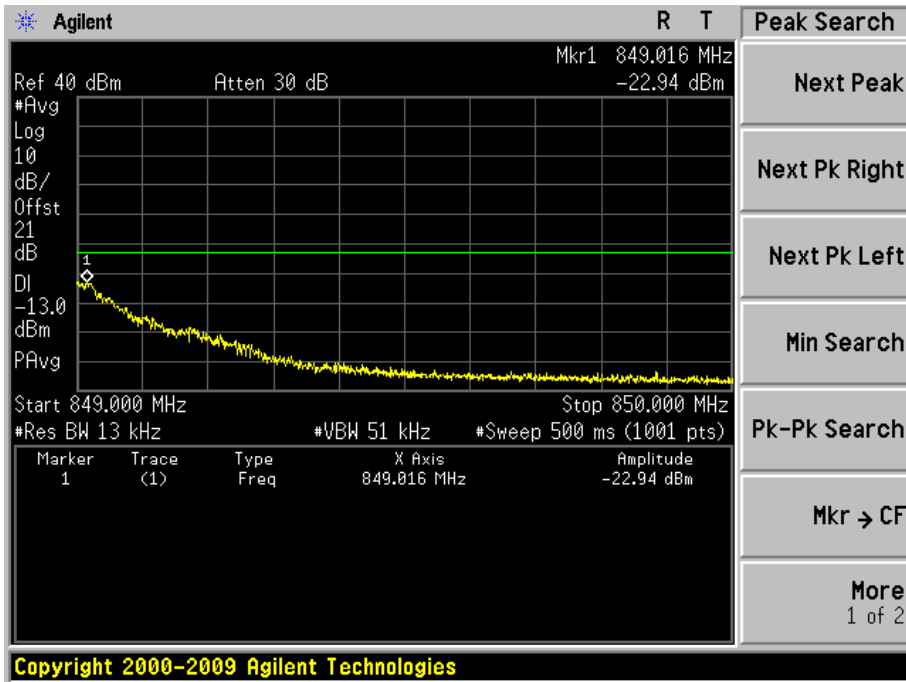
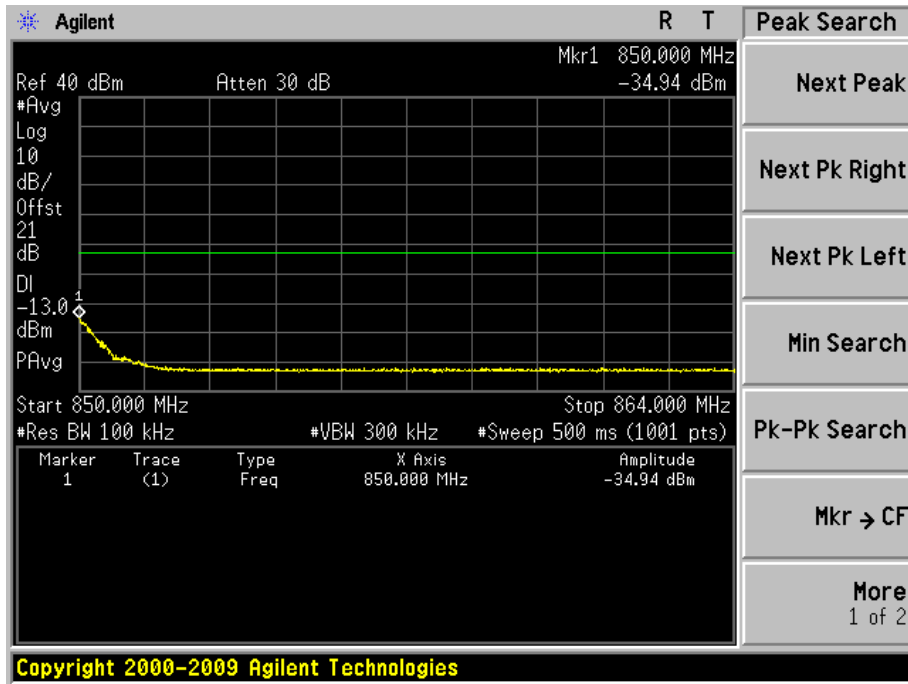
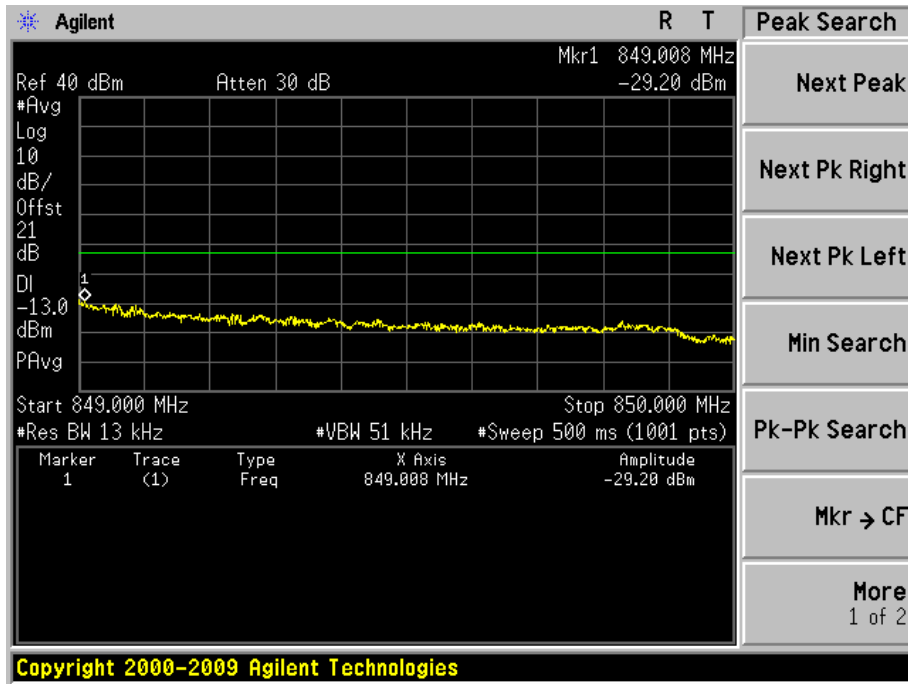

Figure Channel 27033 (848.30MHz)

1RB6



7RB0



Product	Wireless Module		
Test Item	Conducted Band Edge		
Test Mode	Mode 1: LTE Band 26 (1.4M/16QAM)		
Date of Test	2015/07/09	Test Site	AC6

Figure Channel 26797 (824.70MHz)
1RB0

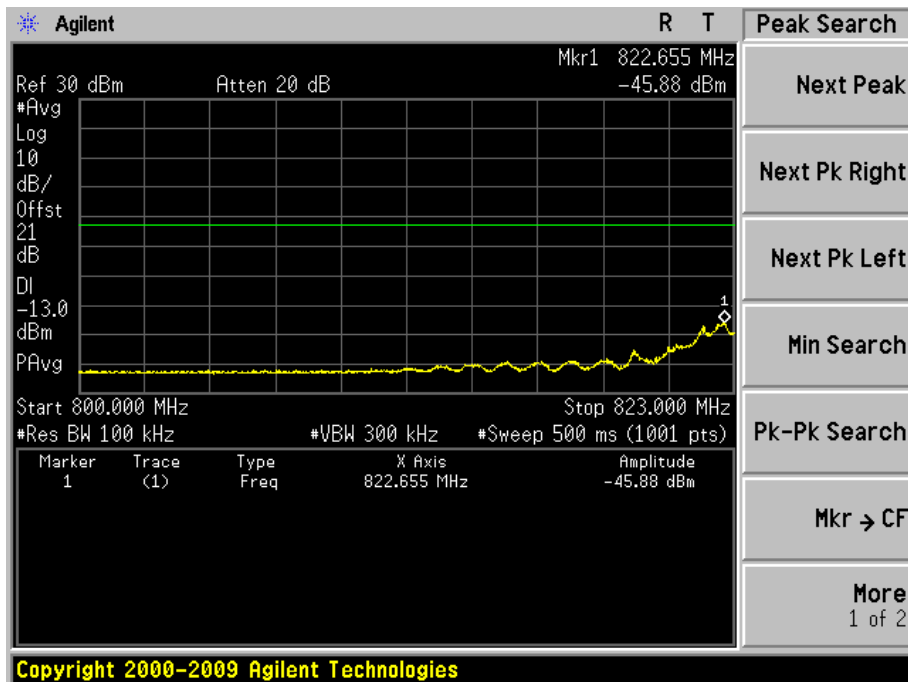
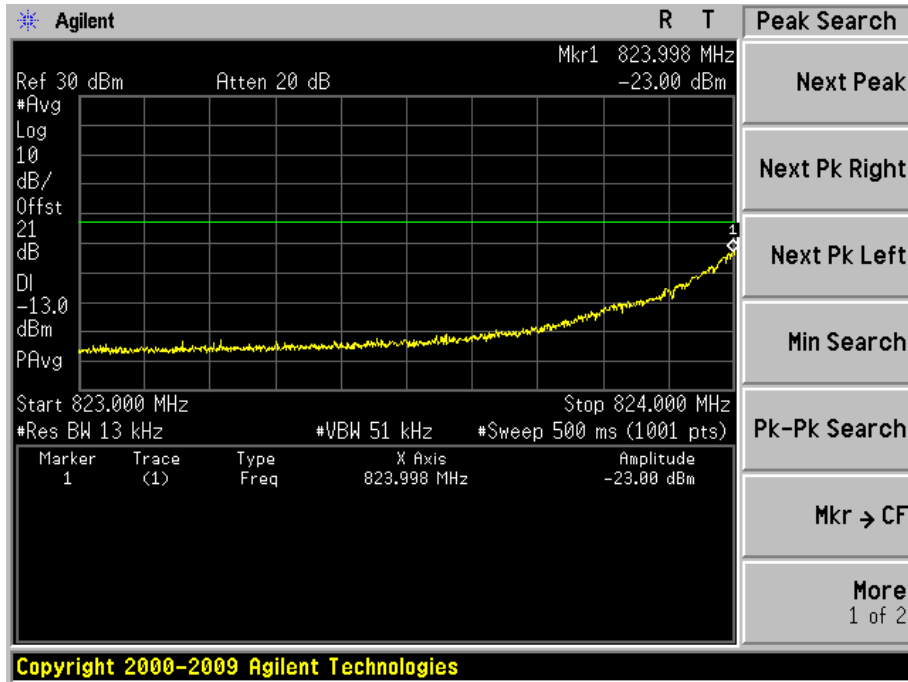

7RB0

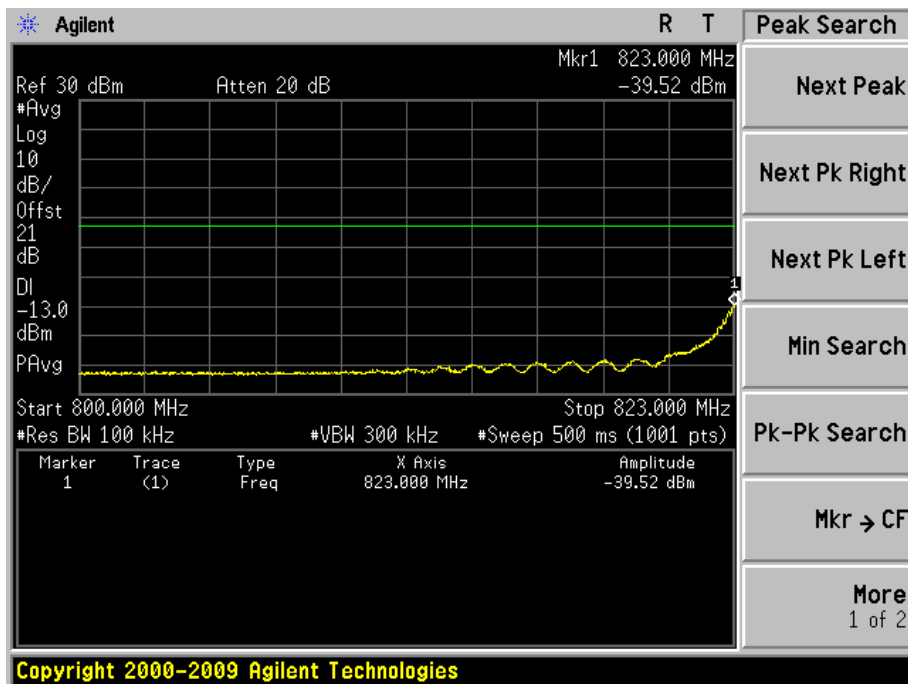
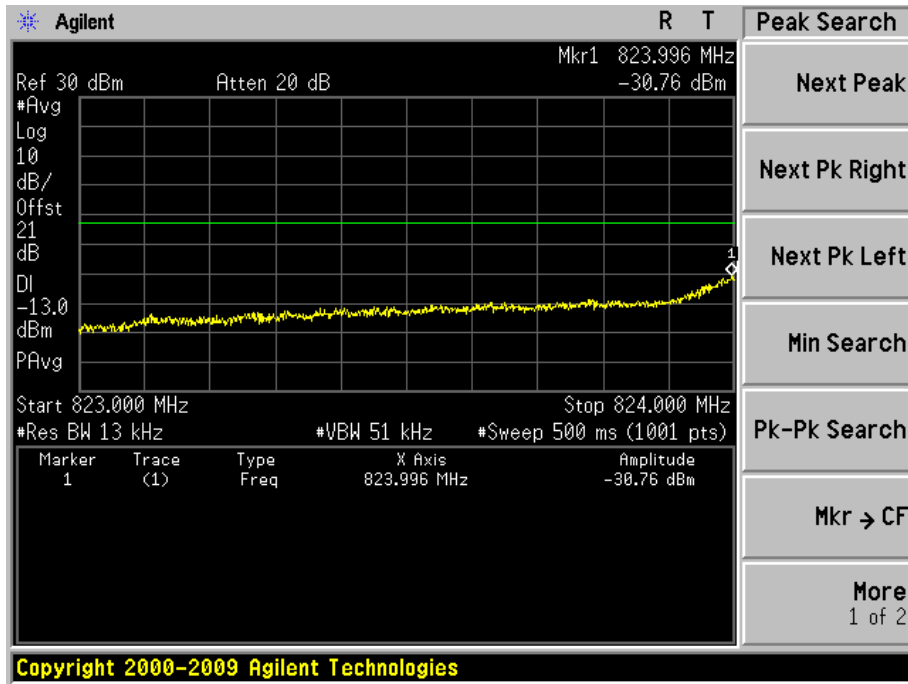
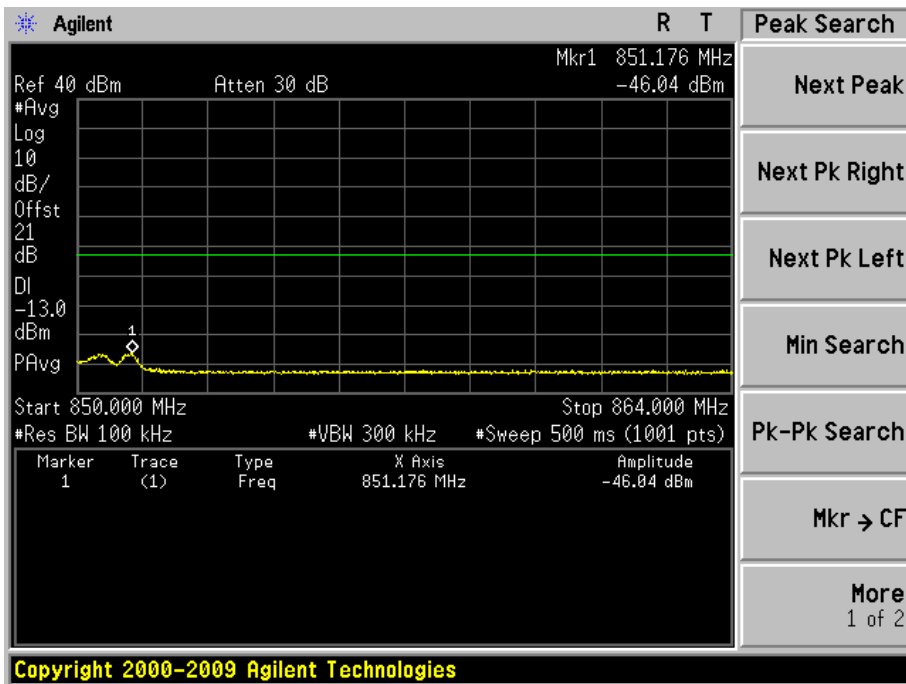
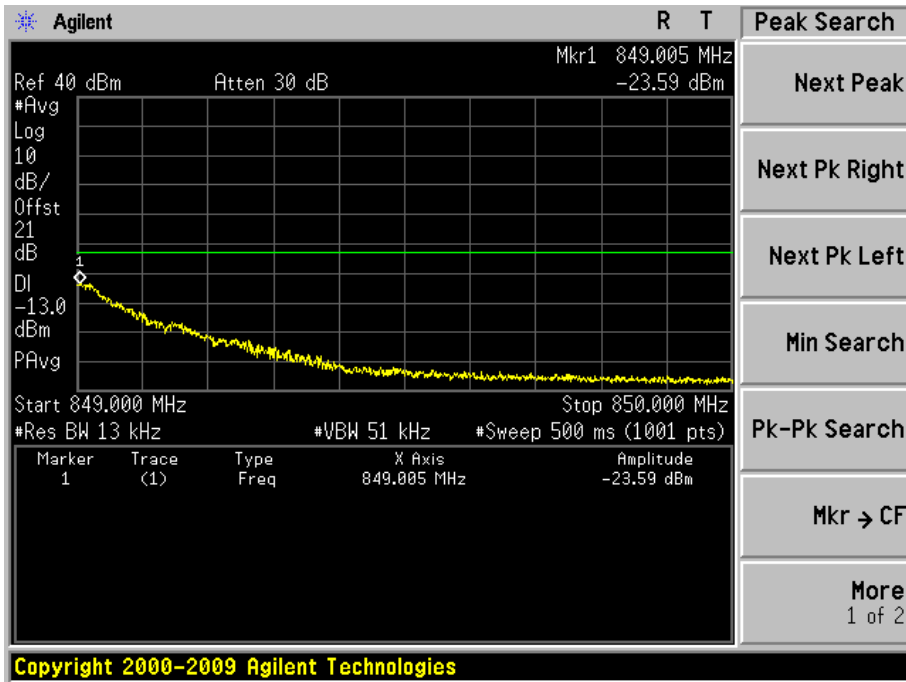
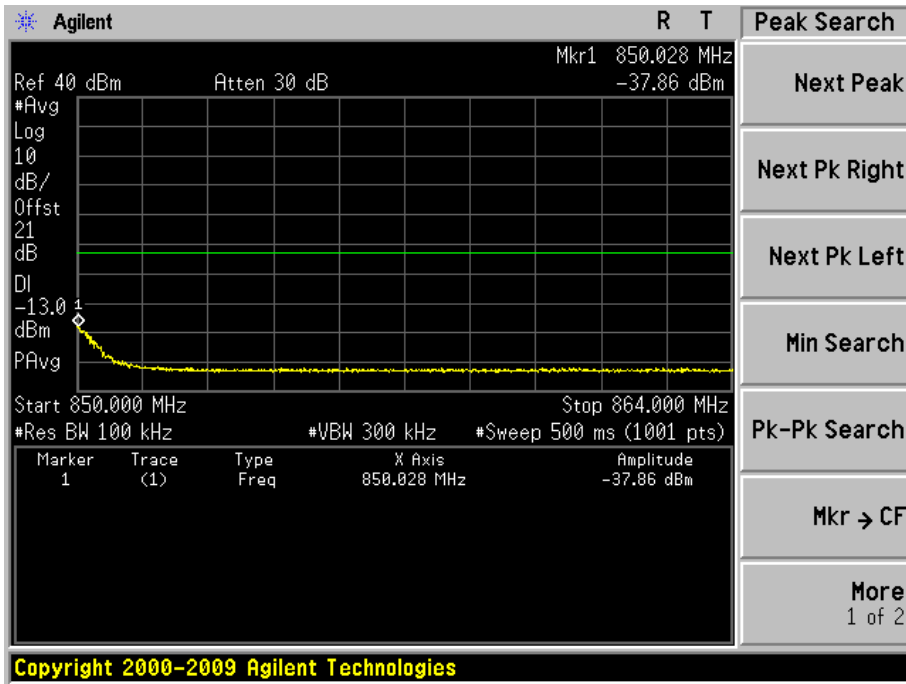
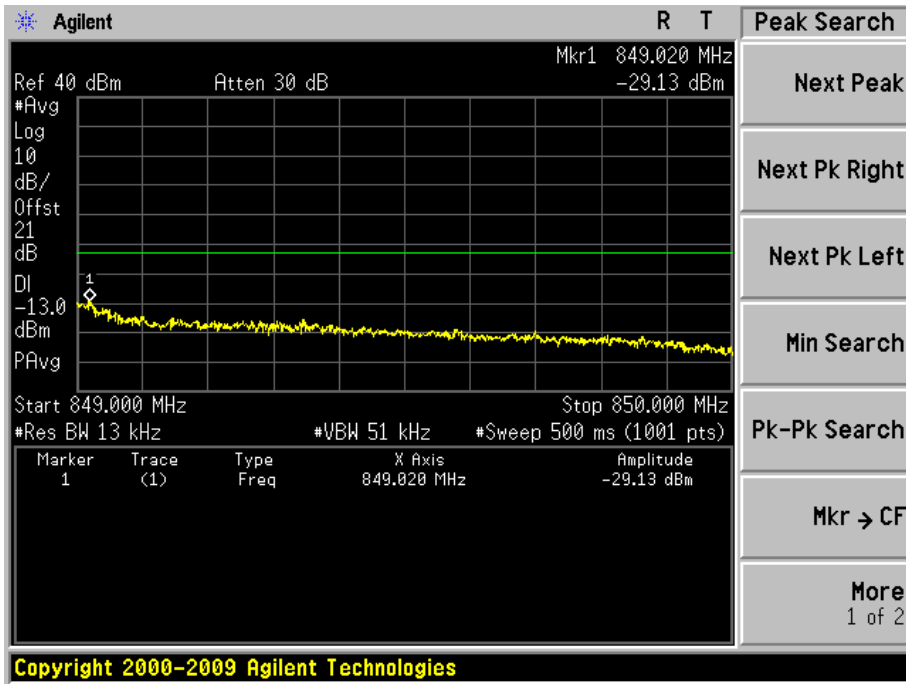

Figure Channel 26683 (1914.30MHz)

1RB6



7RB0



LTE Band 26 For Part 90S

Product	Wireless Module		
Test Item	Conducted Band Edge		
Test Mode	Mode 1: LTE Band 26 (10M/QPSK)		
Date of Test	2015/07/09	Test Site	AC6

Figure Channel 26740 (819.00MHz)
1RB0

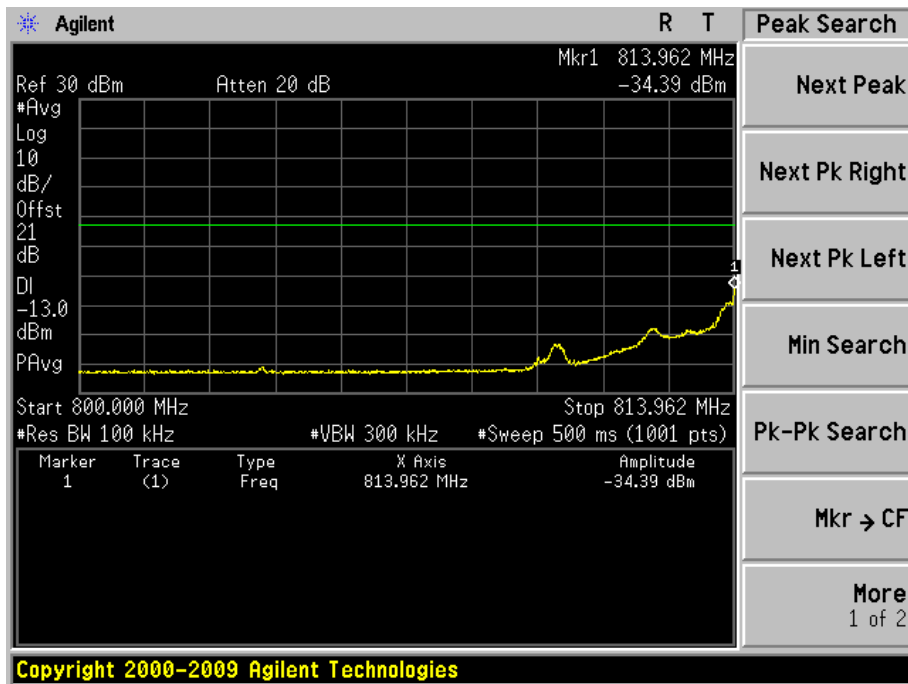
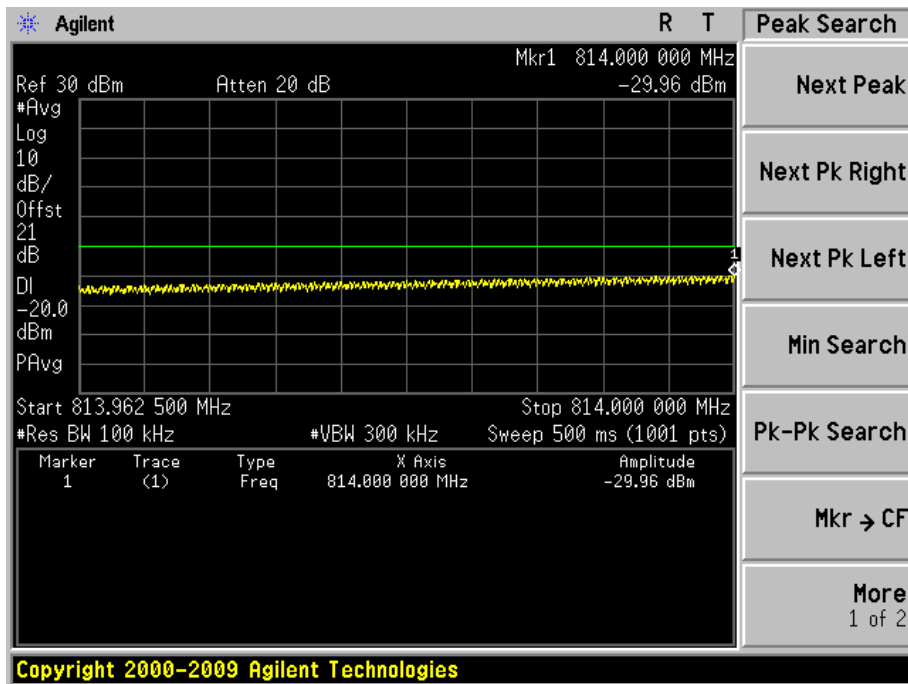

50RB0

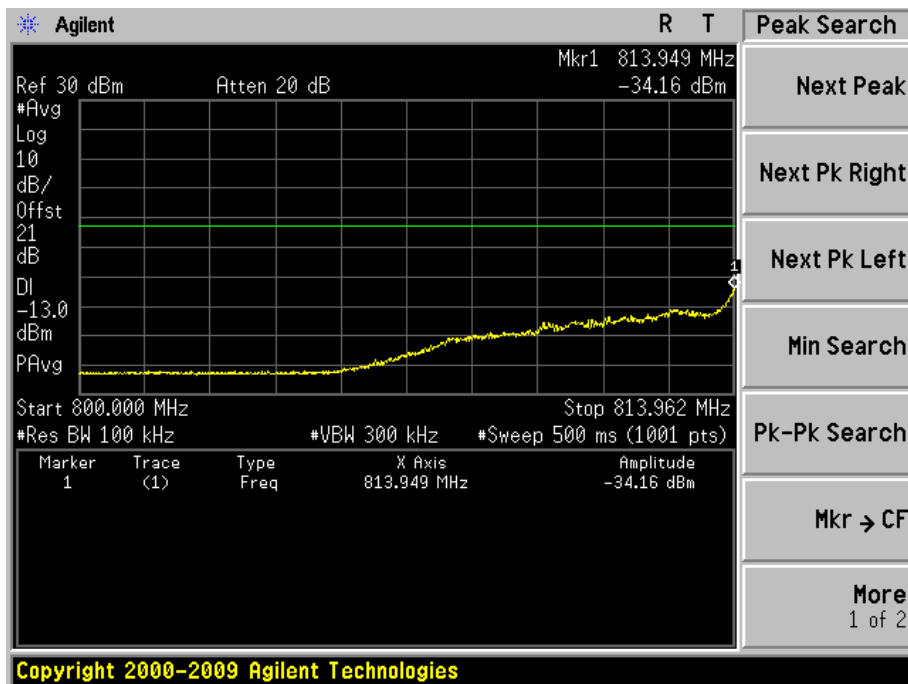
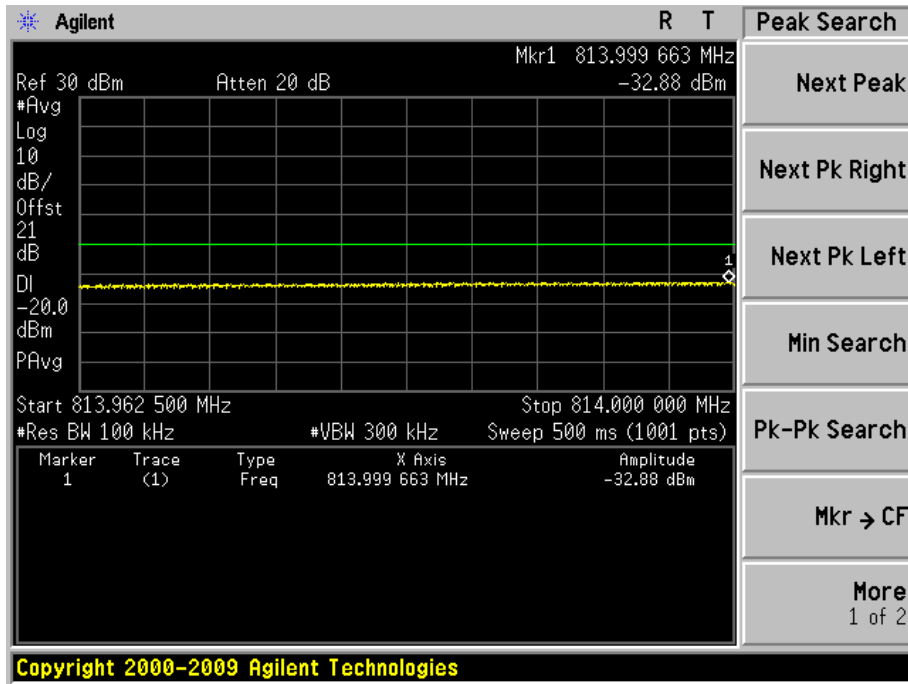
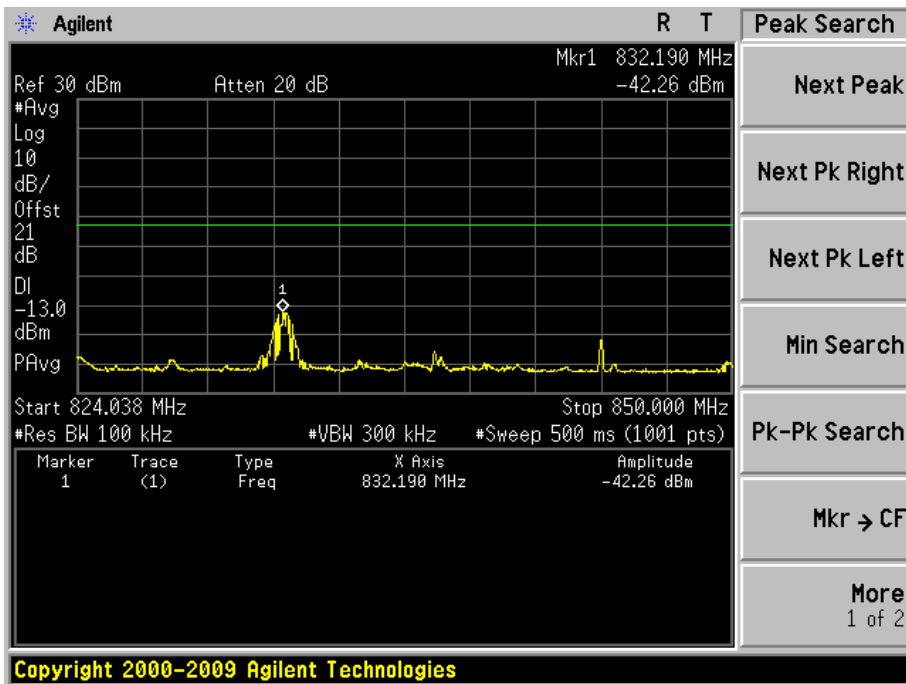
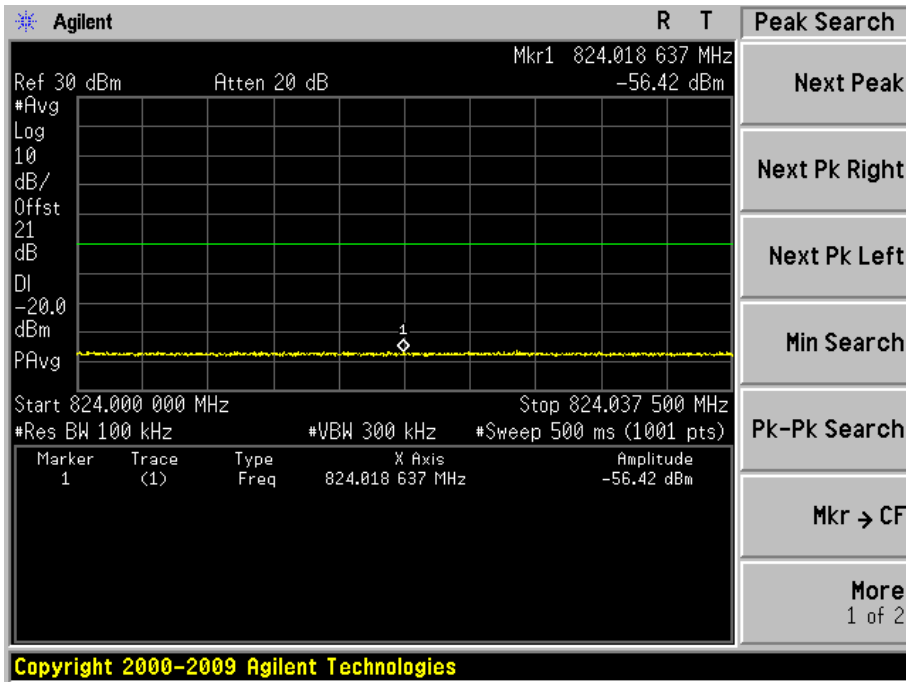
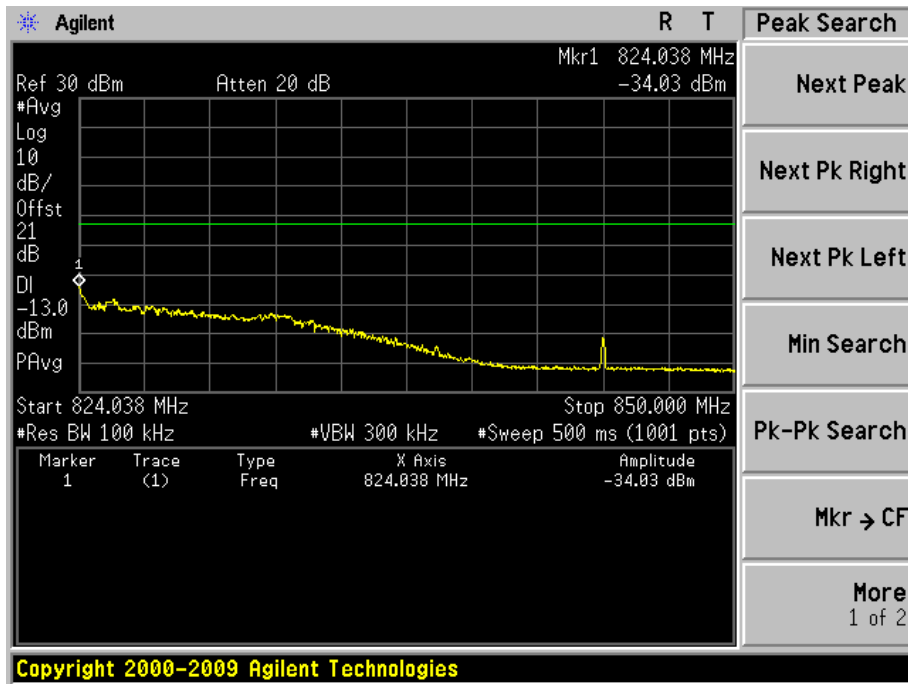
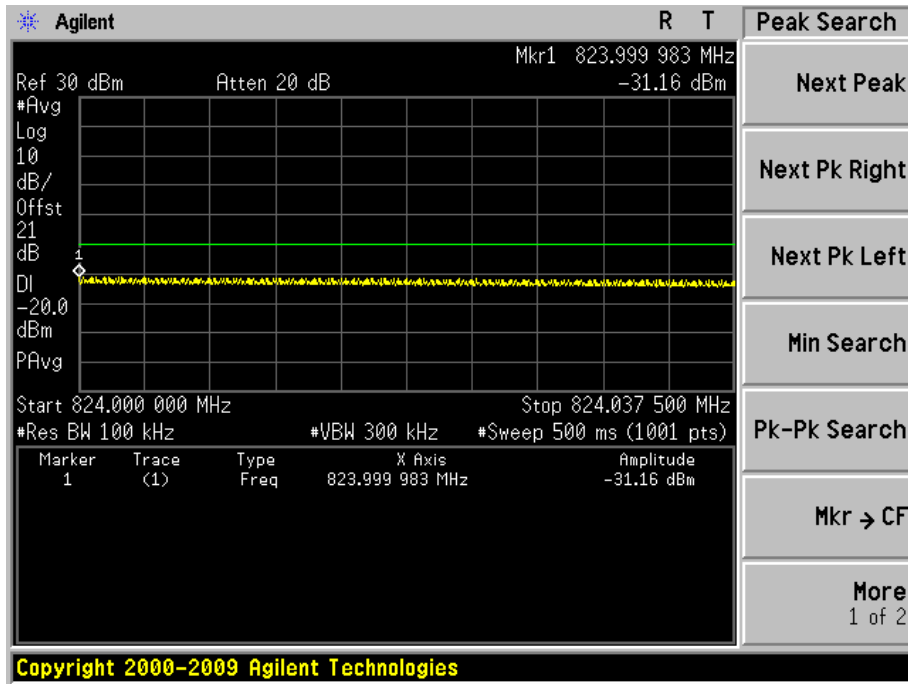

Figure Channel 26740 (819.00MHz)

1RB0



50RB0



Product	Wireless Module		
Test Item	Conducted Band Edge		
Test Mode	Mode 1: LTE Band 26 (10M/16QAM)		
Date of Test	2015/07/09	Test Site	AC6

Figure Channel 26740 (819.00MHz)
1RB0

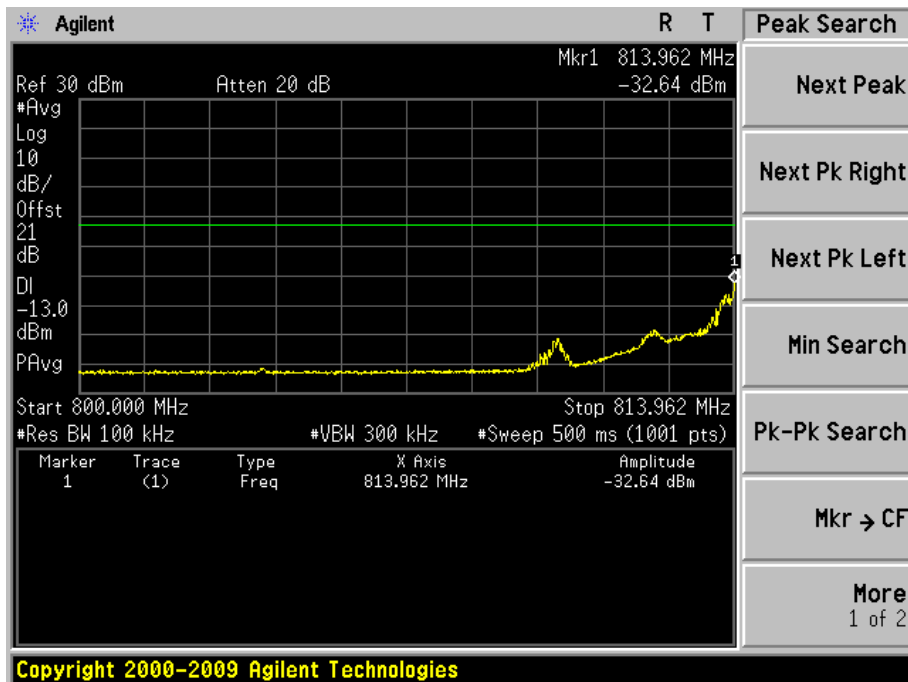
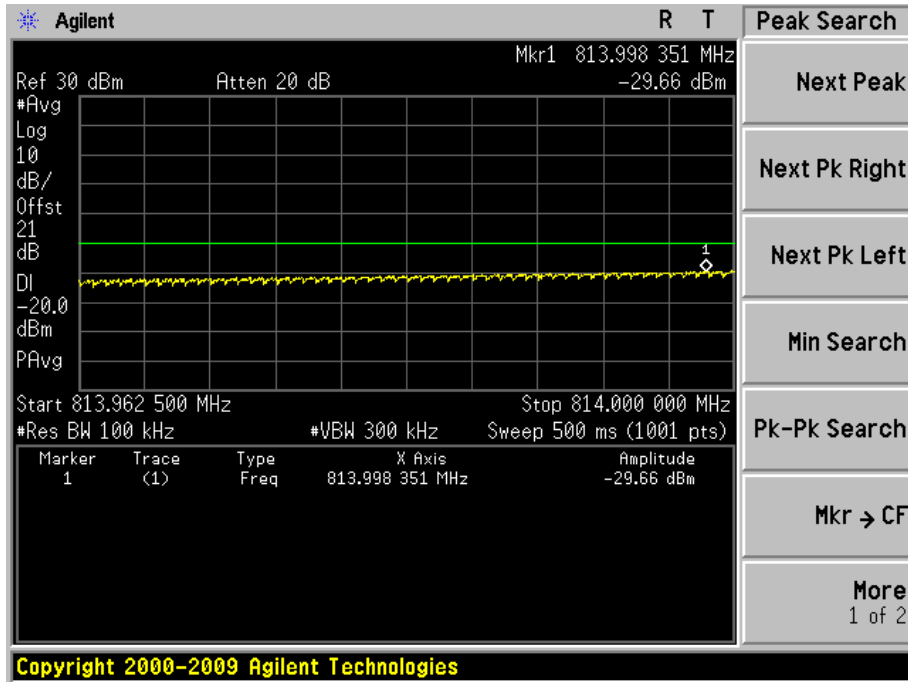

50RB0

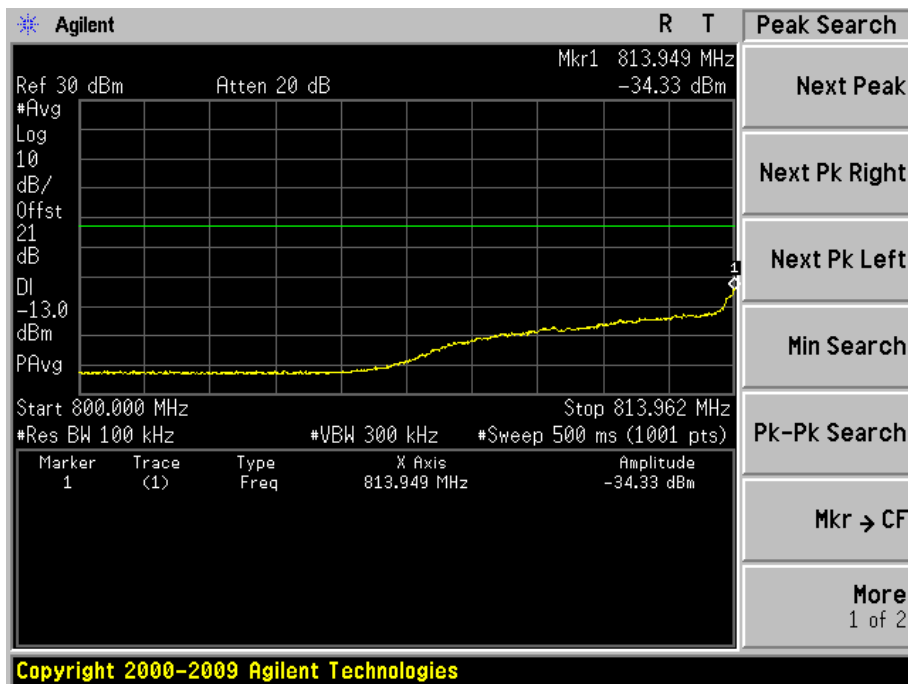
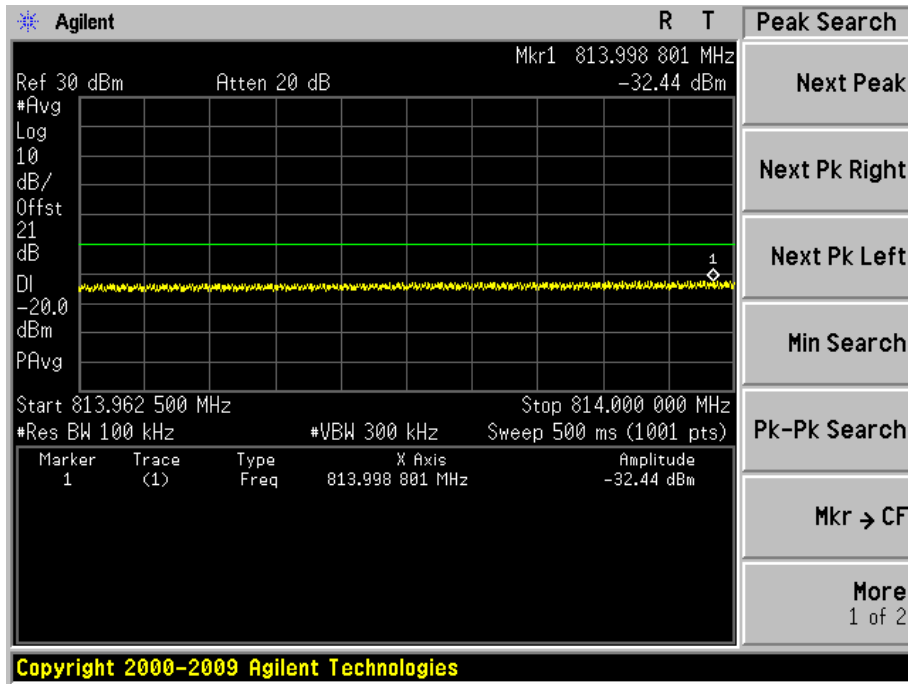
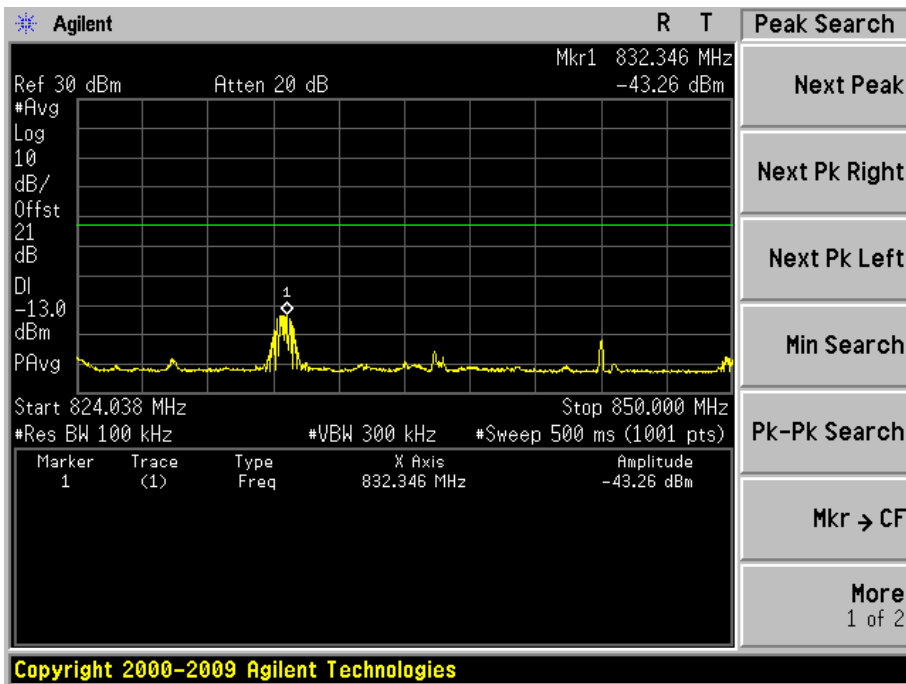
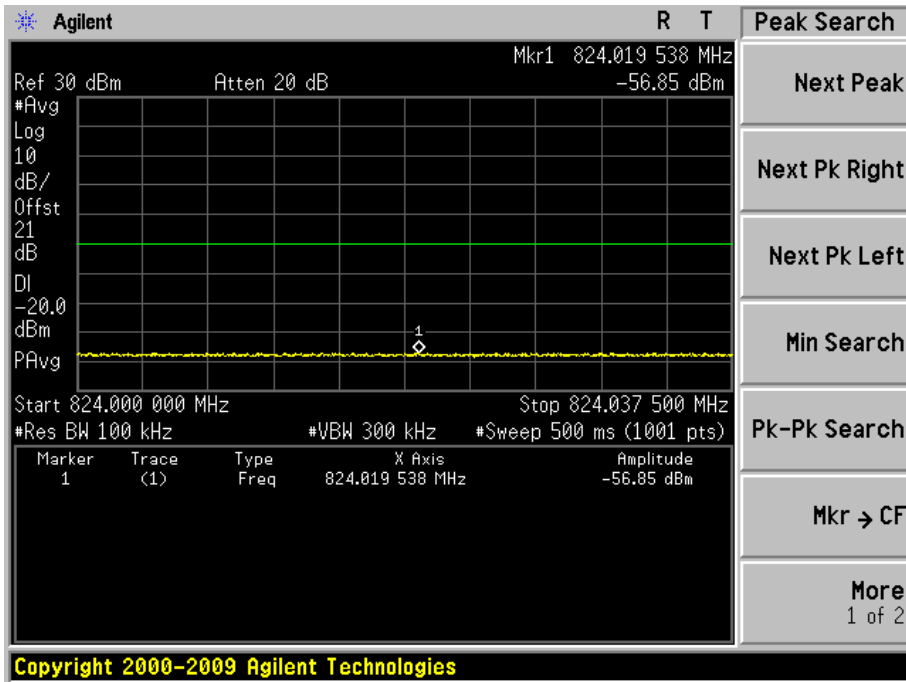
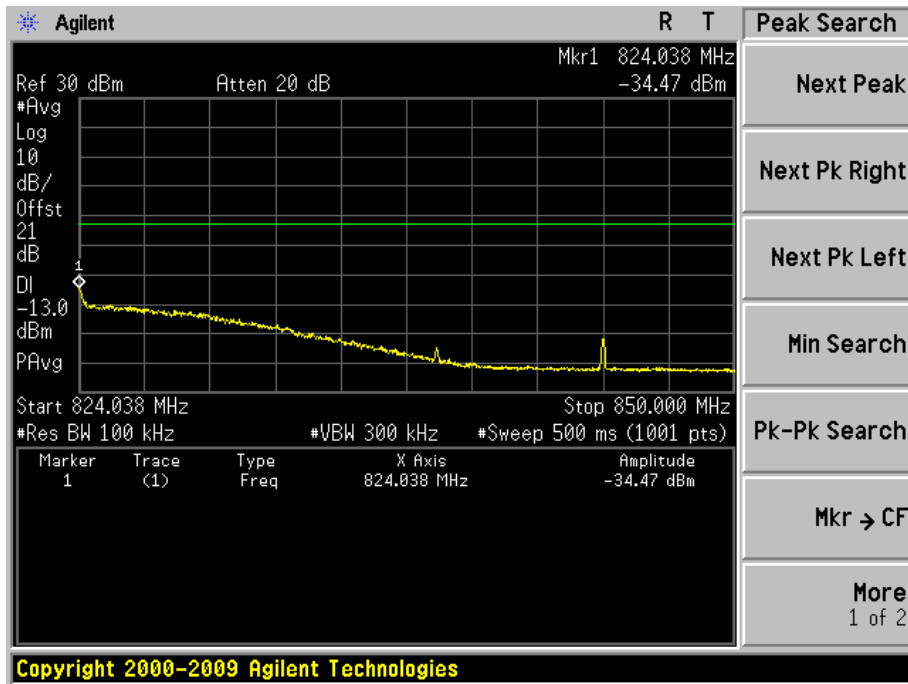
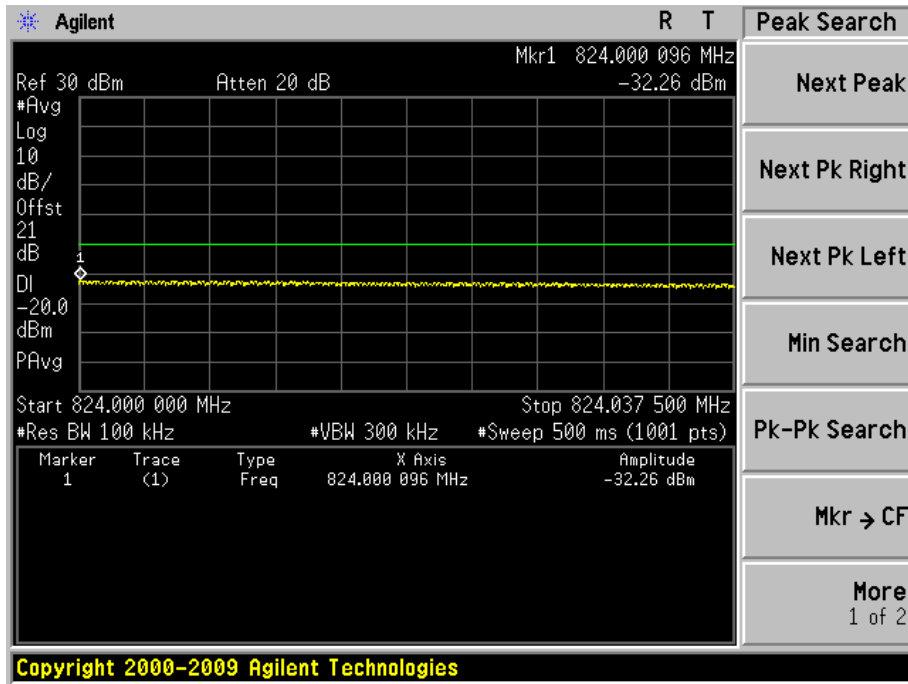

Figure Channel 26740 (819.00MHz)

1RB0



50RB0



Product	Wireless Module		
Test Item	Conducted Band Edge		
Test Mode	Mode 1: LTE Band 26 (5M/QPSK)		
Date of Test	2015/07/09	Test Site	AC6

Figure Channel 26715 (816.5MHz)

1RB0

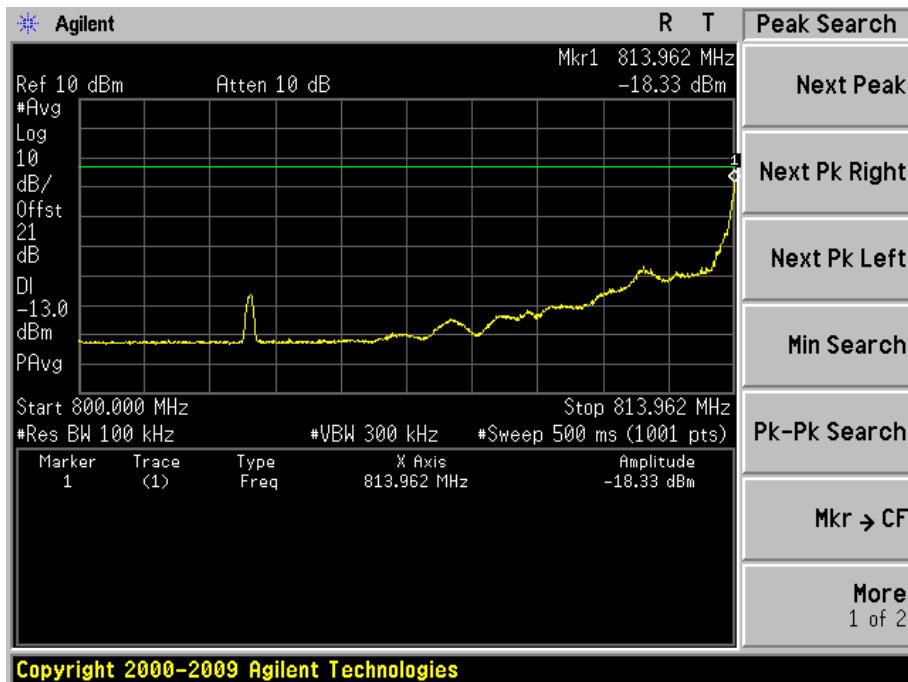
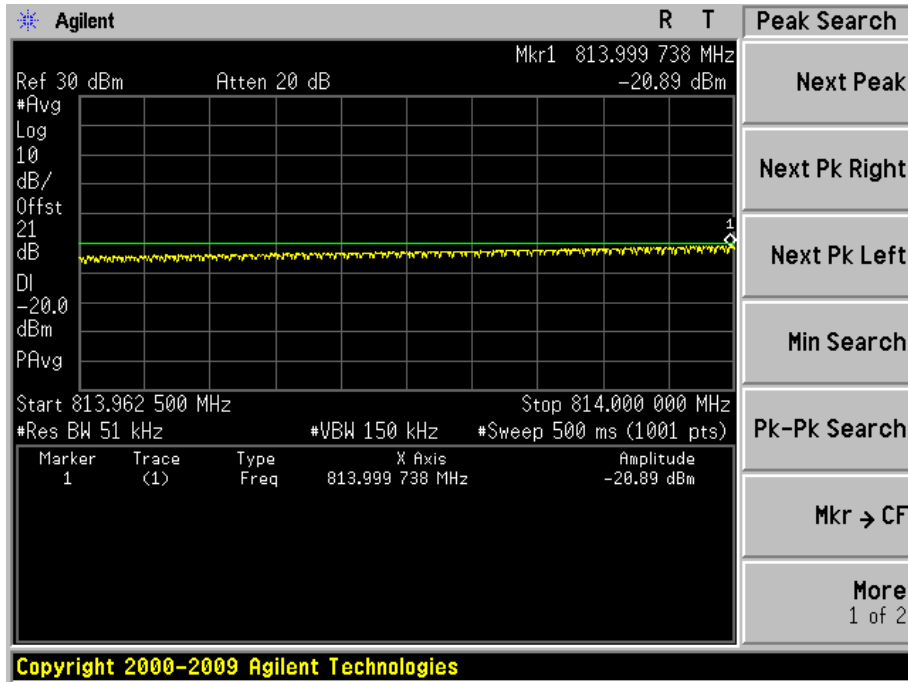

25RB0

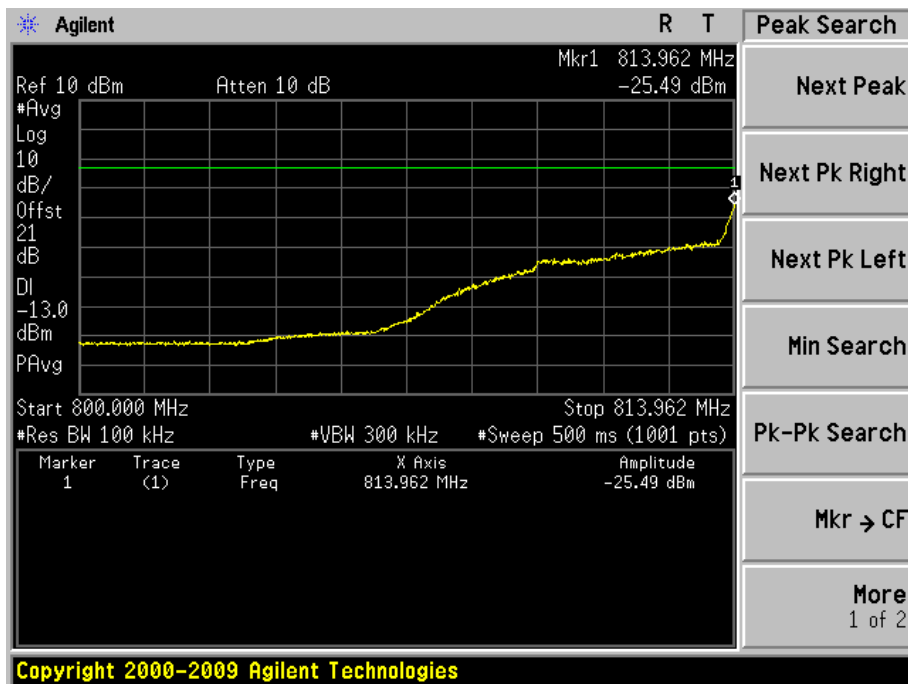
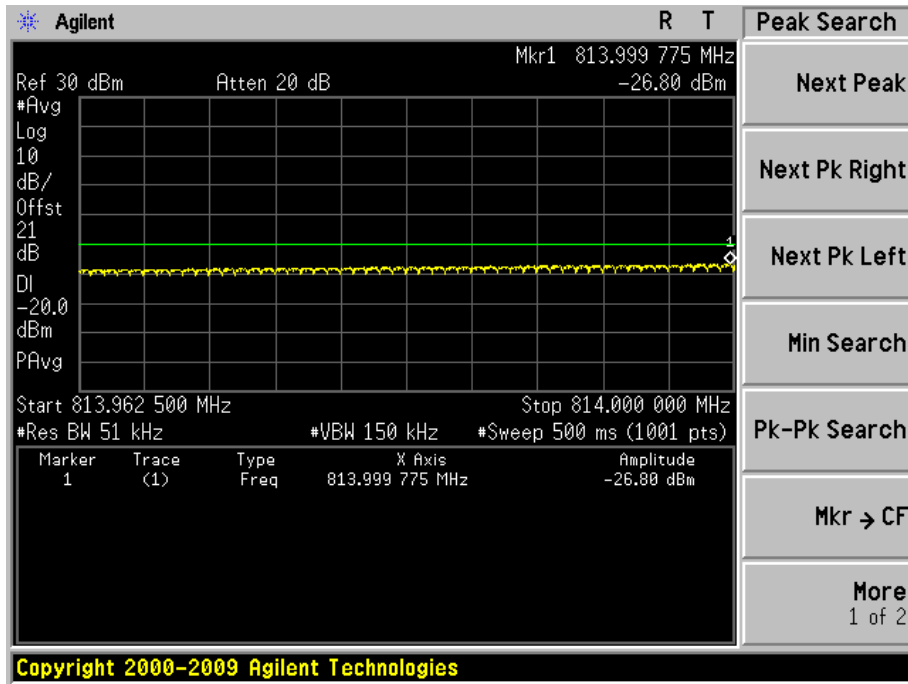
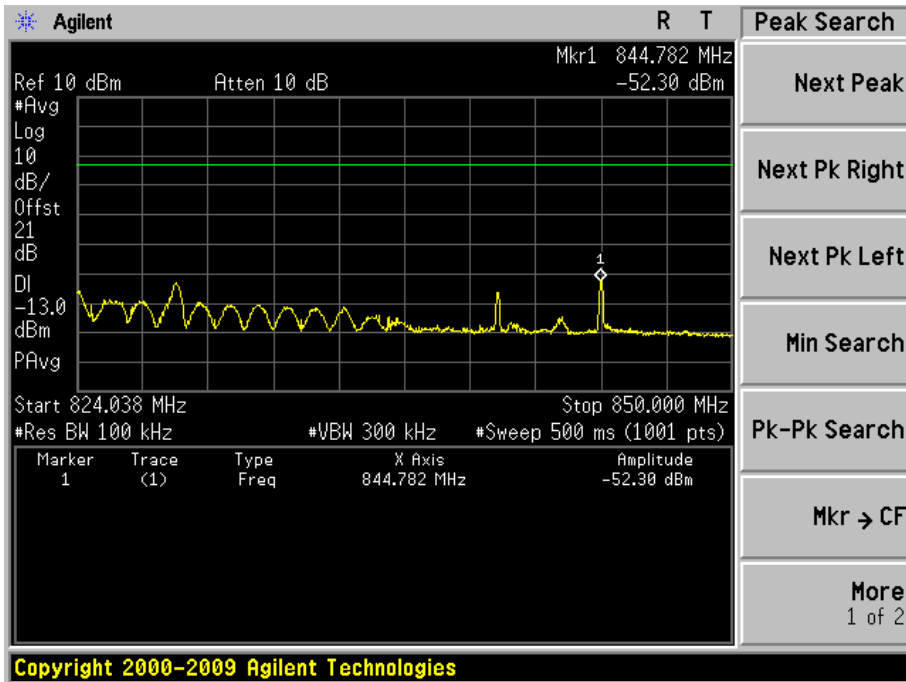
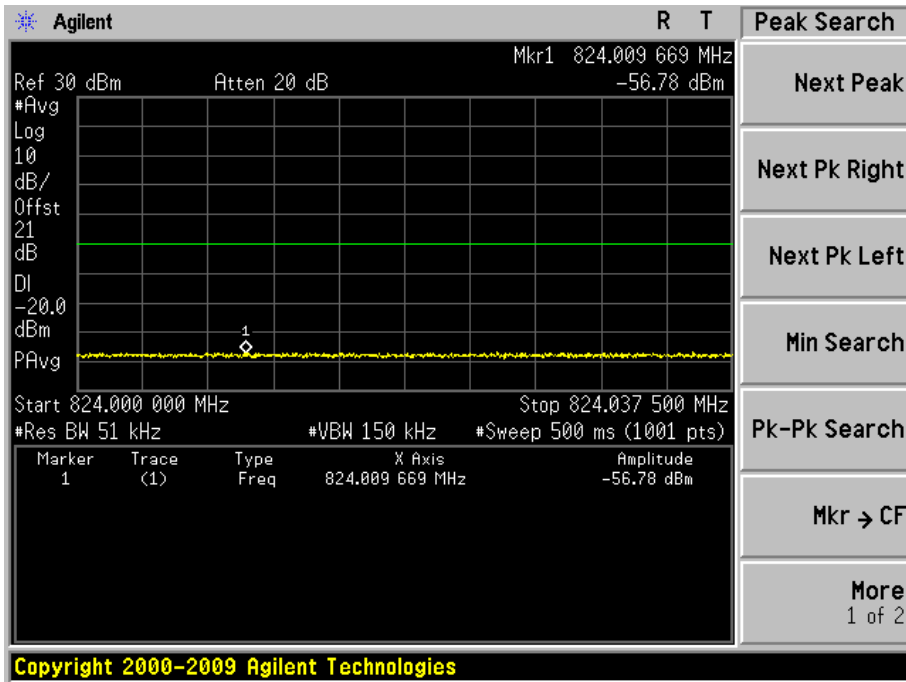
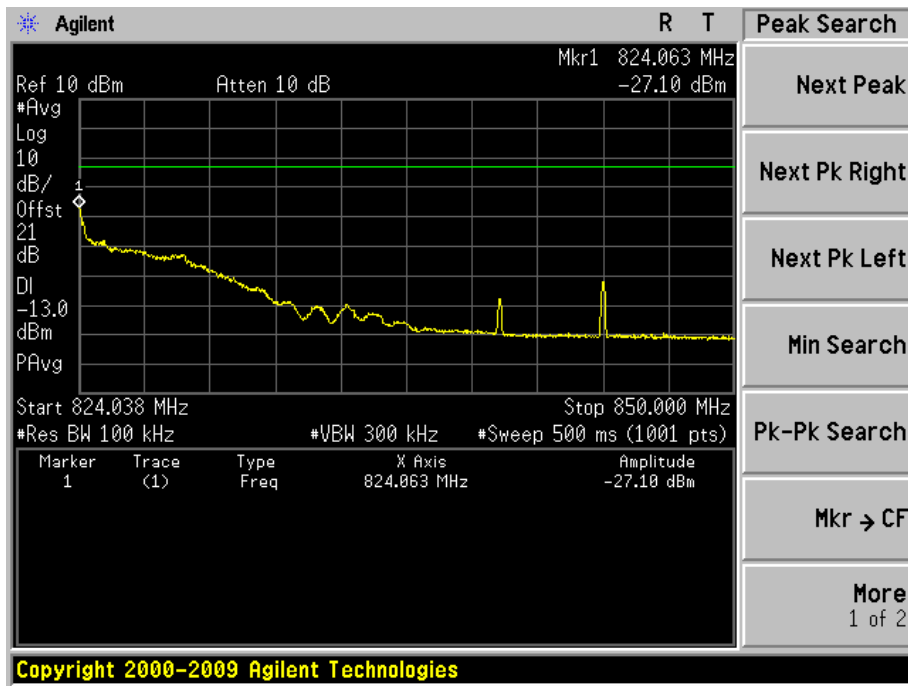
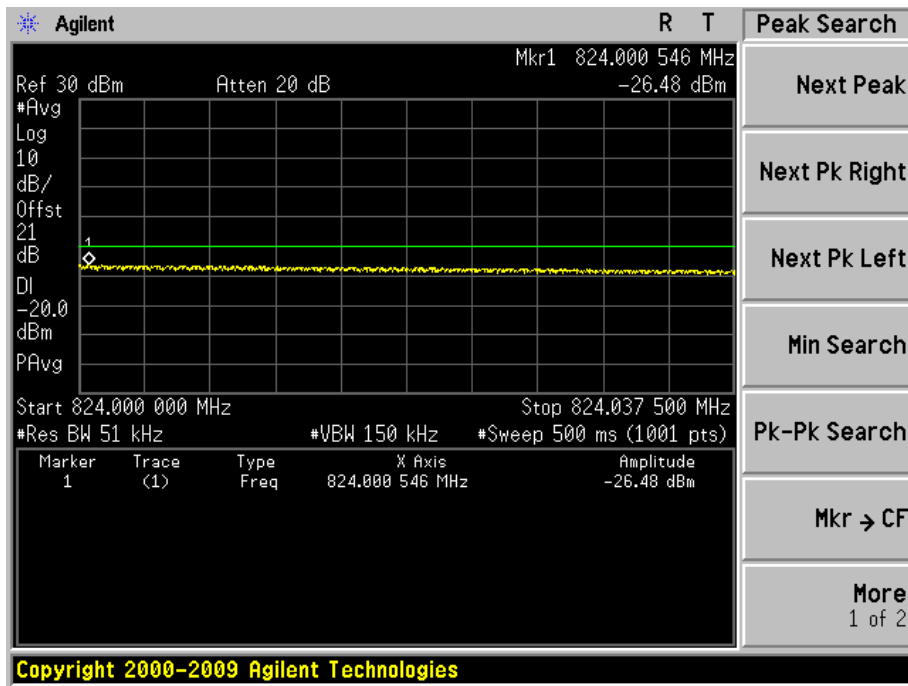

Figure Channel 26765 (821.50MHz)

1RB24



25RB0



Product	Wireless Module		
Test Item	Conducted Band Edge		
Test Mode	Mode 1: LTE Band 26 (5M/16QAM)		
Date of Test	2015/07/09	Test Site	AC6

Figure Channel 26715 (816.5MHz)

1RB0

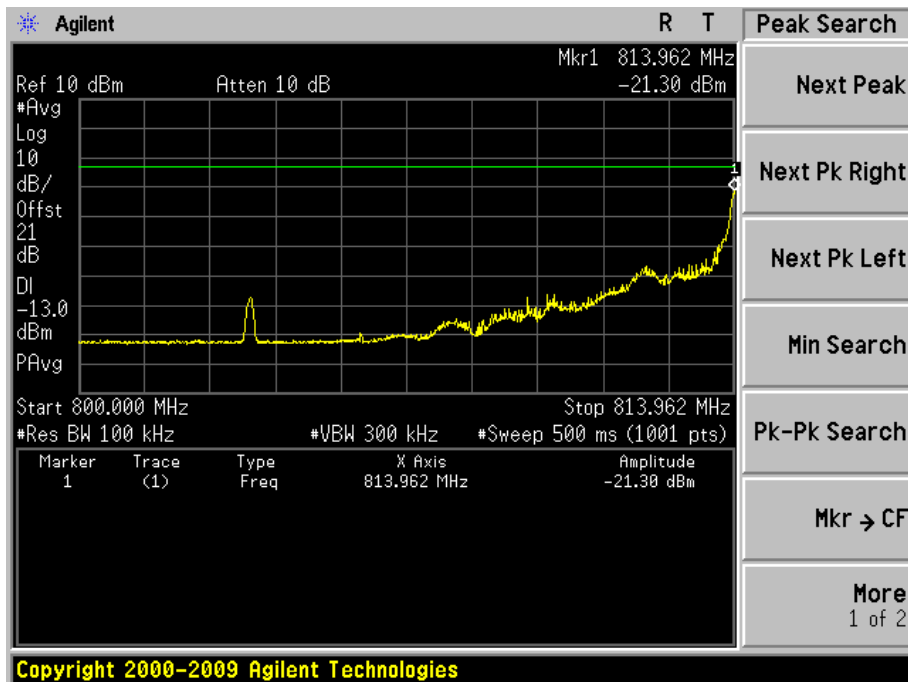
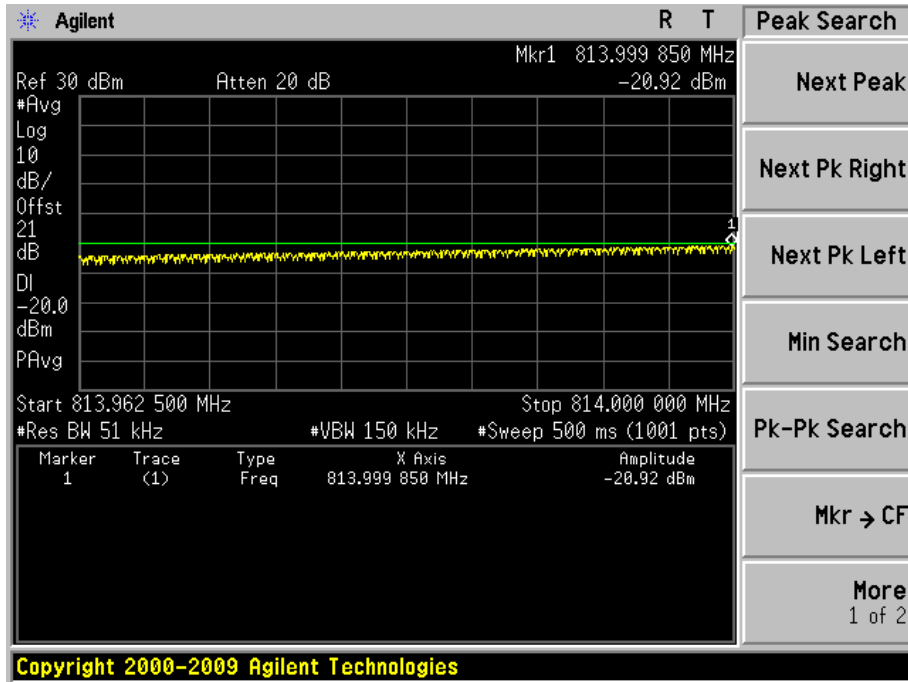

25RB0

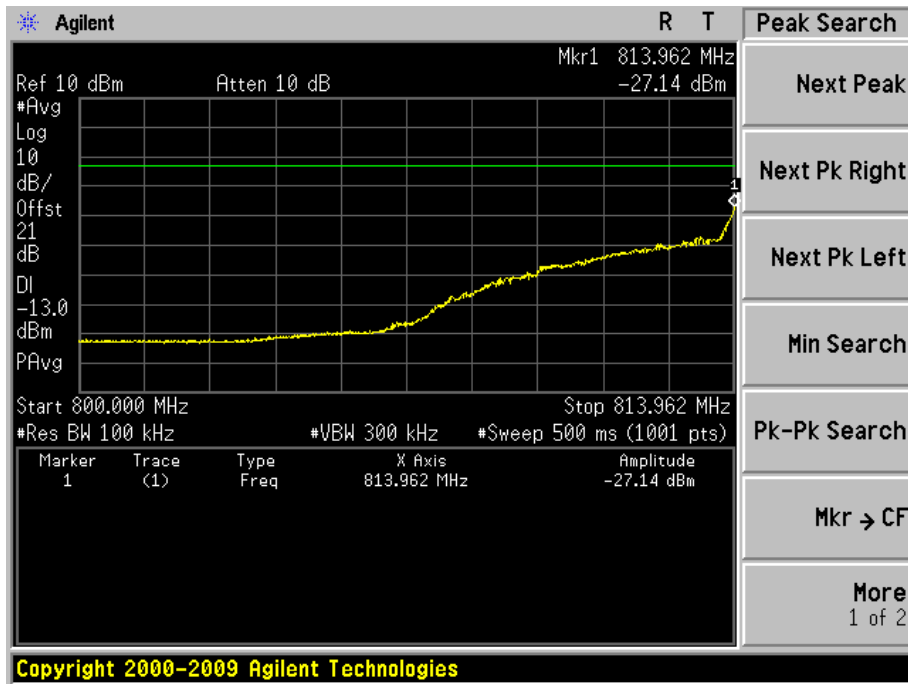
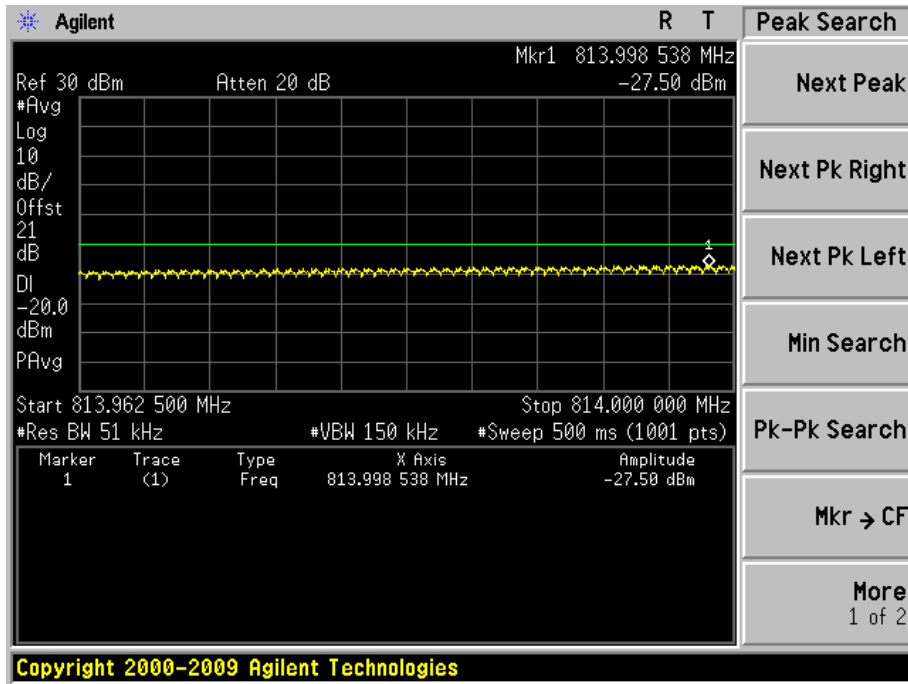
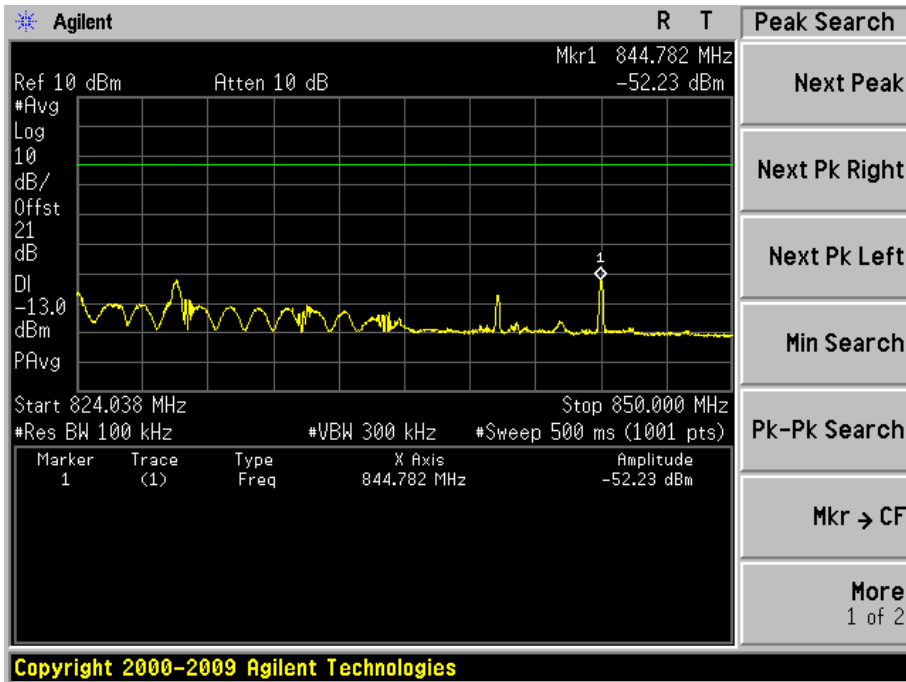
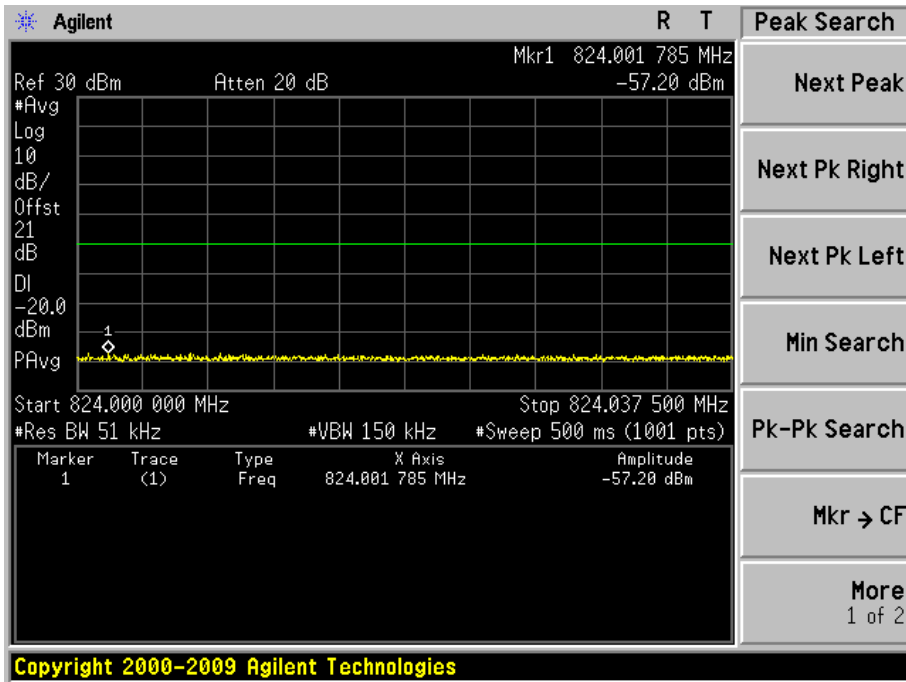
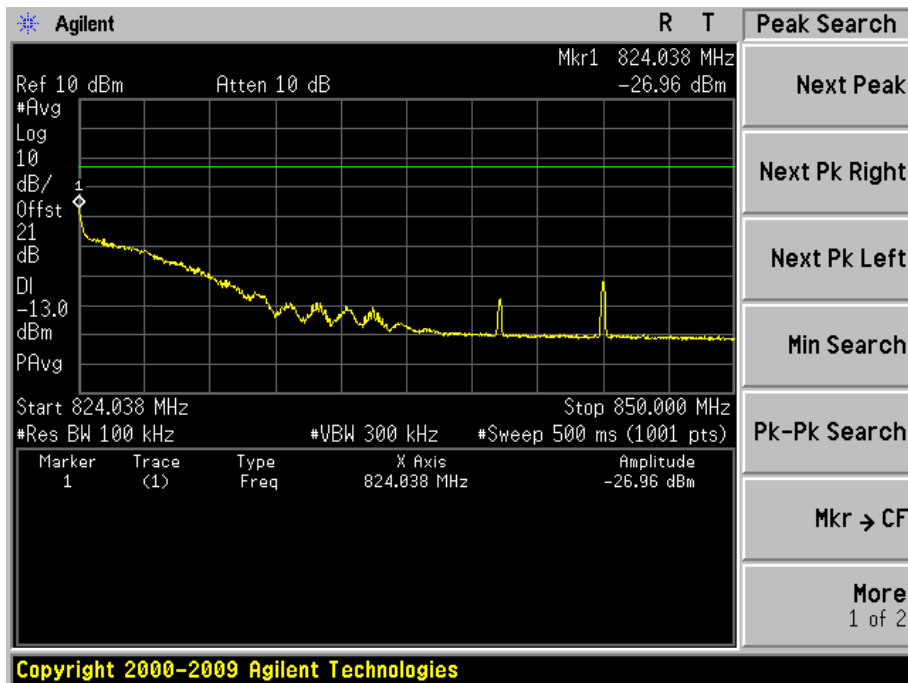
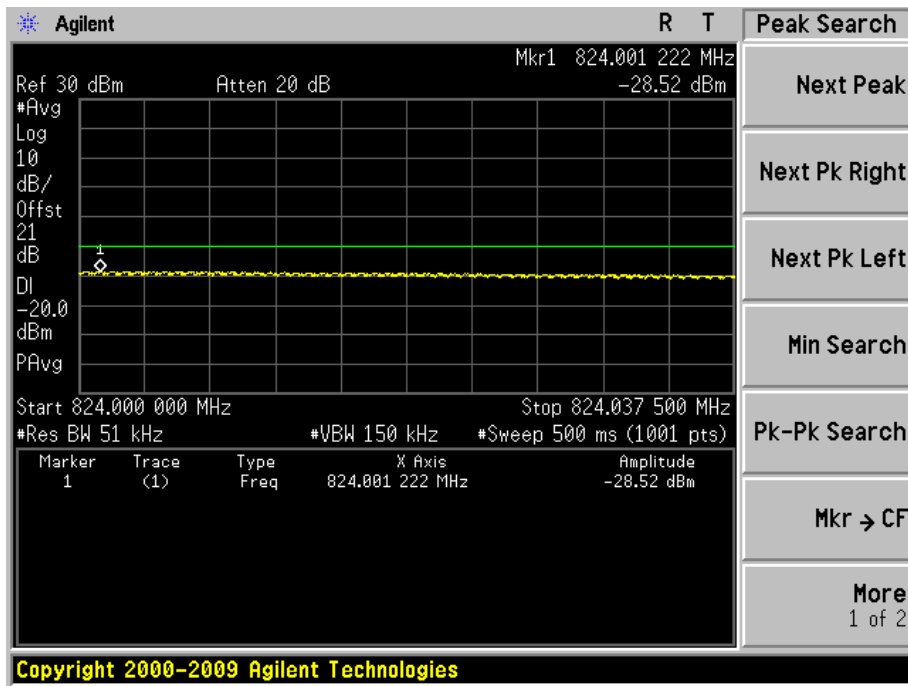

Figure Channel 26765 (821.50MHz)

1RB24



25RB0



Product	Wireless Module		
Test Item	Conducted Band Edge		
Test Mode	Mode 1: LTE Band 26 (3M/QPSK)		
Date of Test	2015/07/09	Test Site	AC6

Figure Channel 26705 (815.50MHz)
1RB0

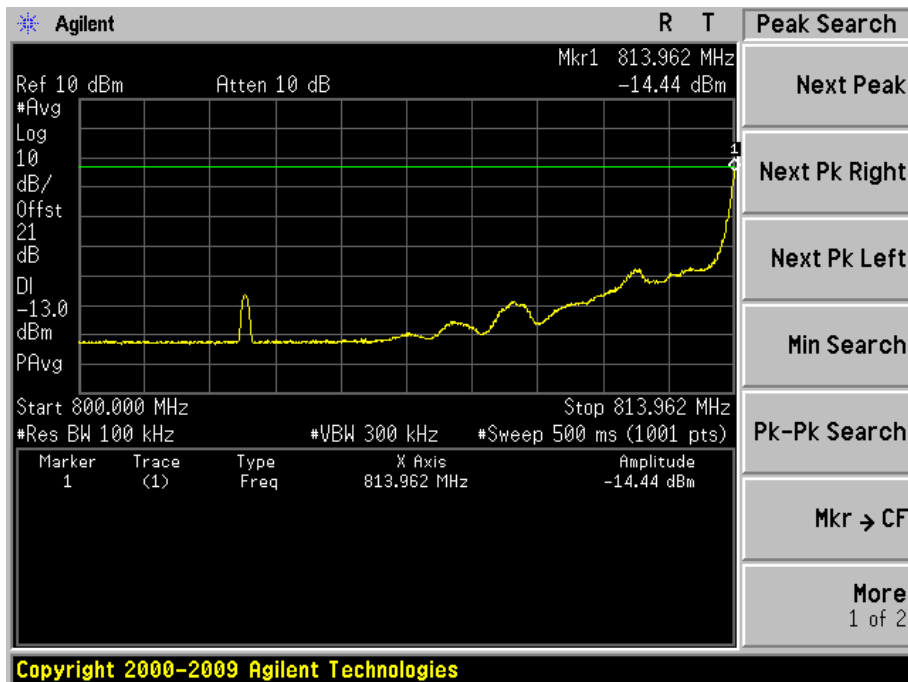
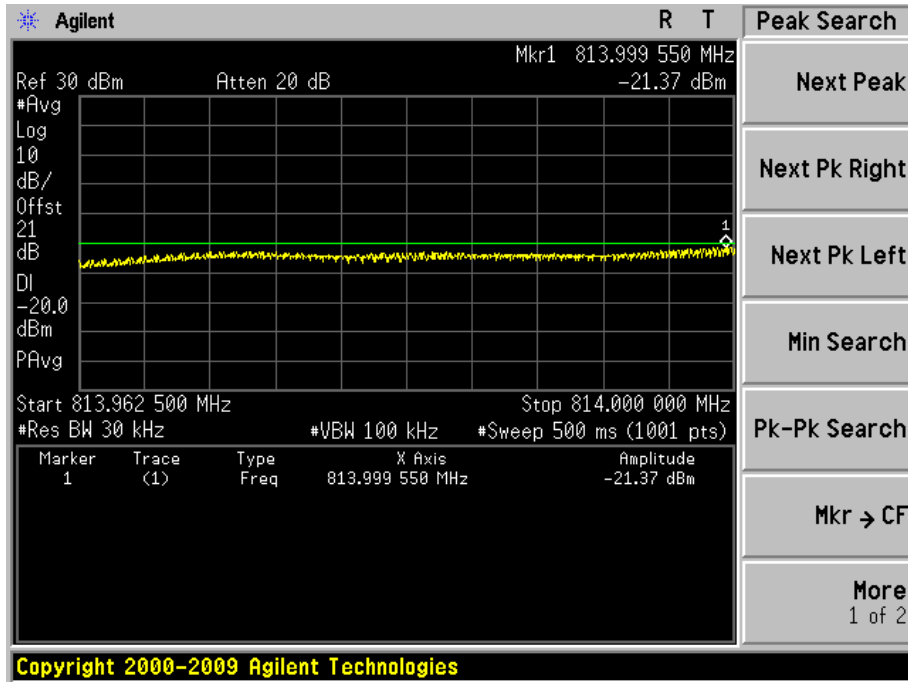

15RB0

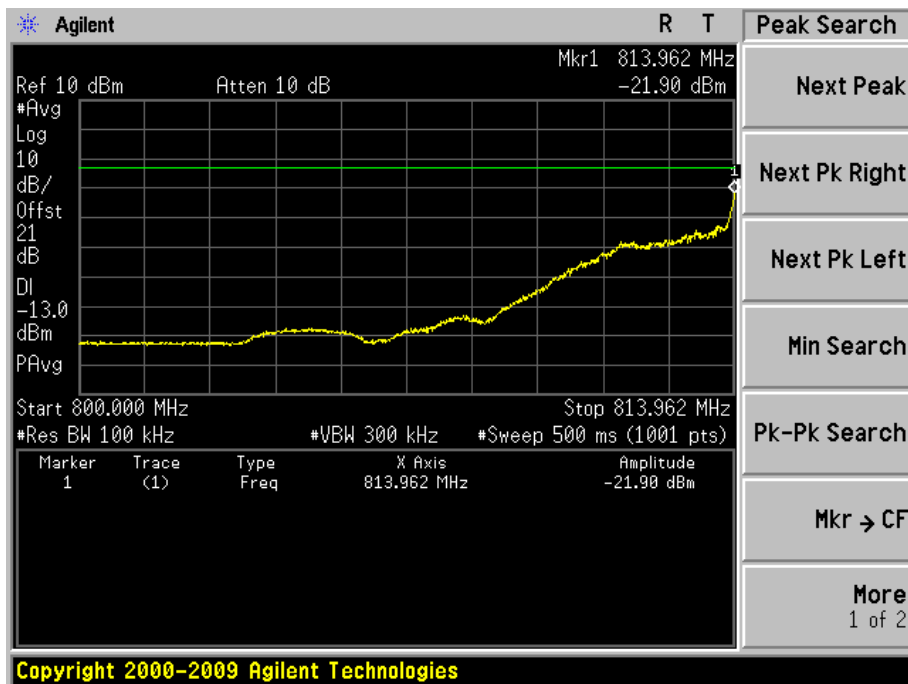
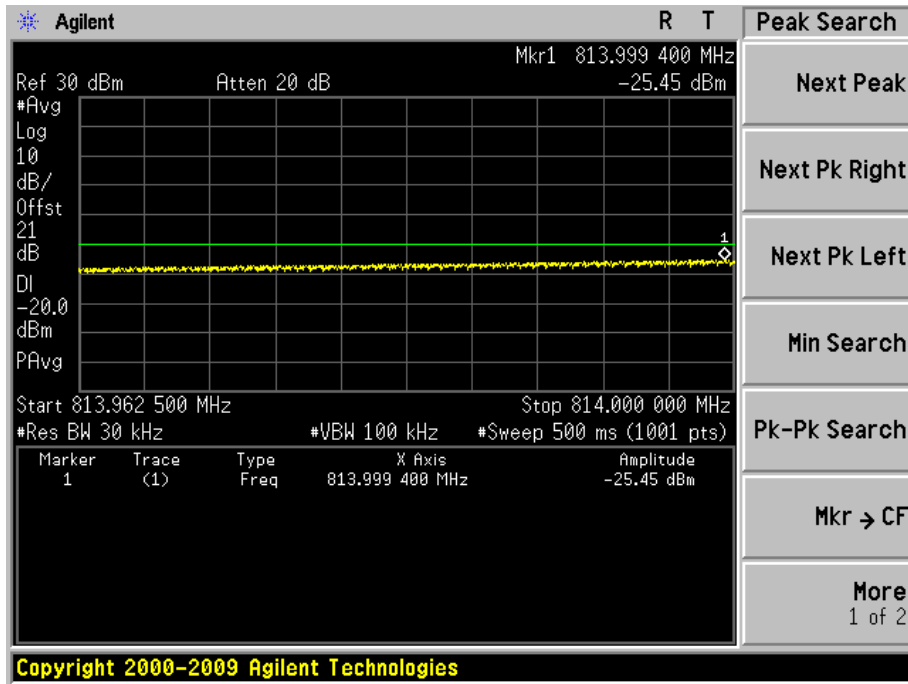
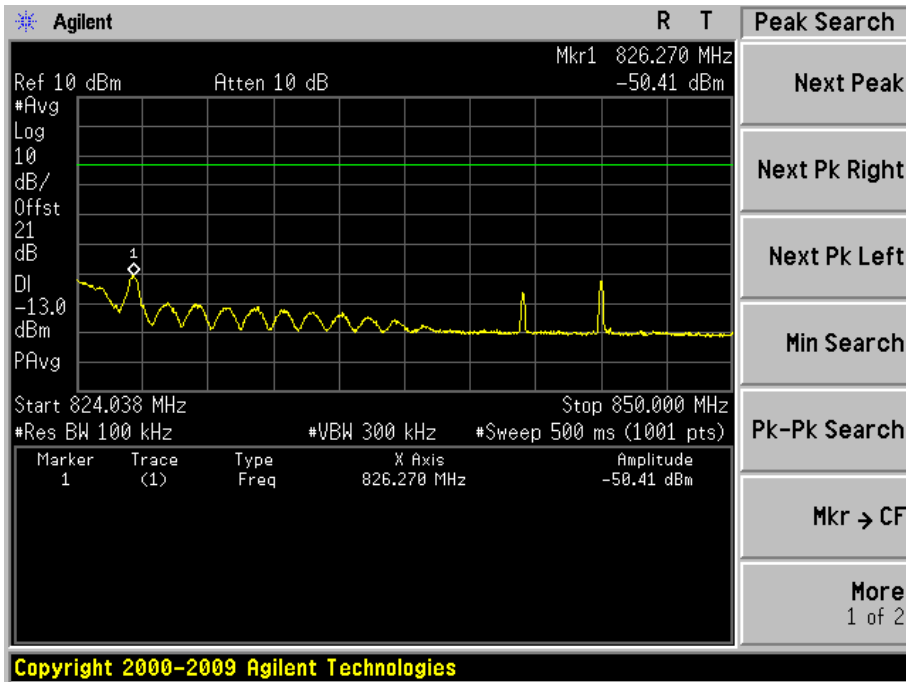
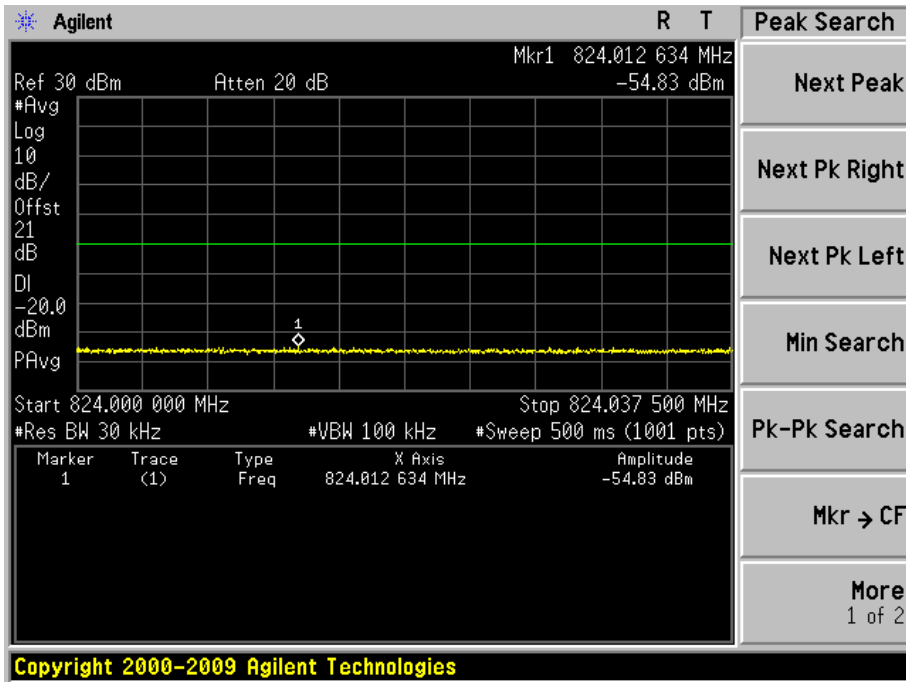
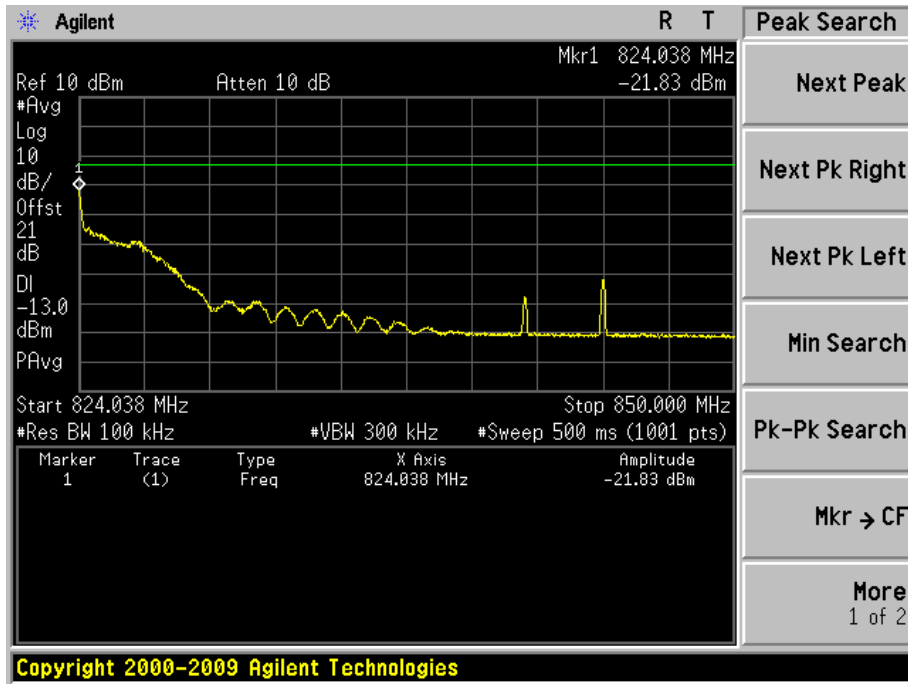
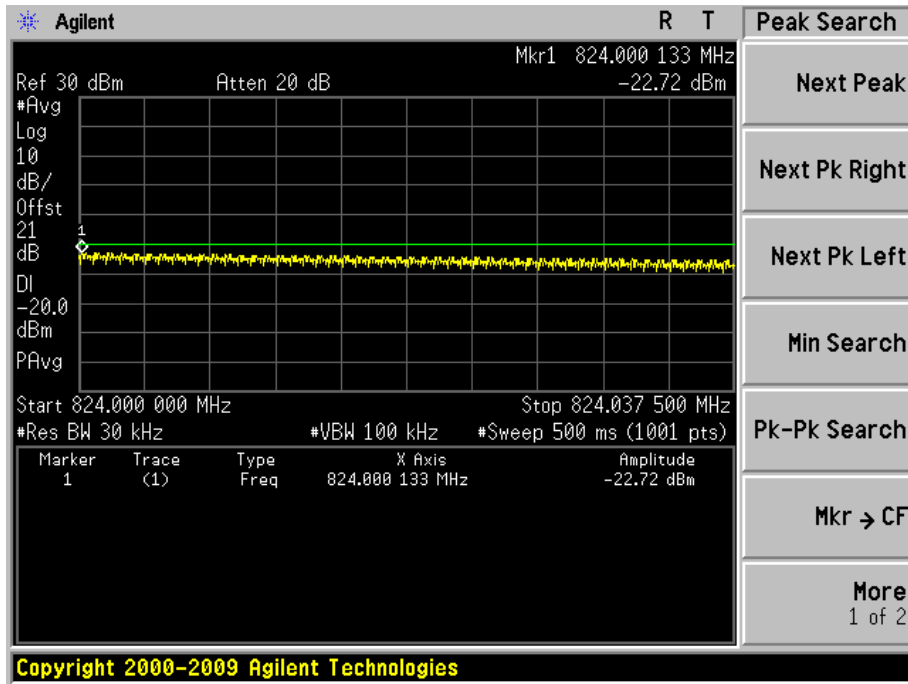

Figure Channel 26775 (822.50MHz)

1RB14



15RB0



Product	Wireless Module		
Test Item	Conducted Band Edge		
Test Mode	Mode 1: LTE Band 26 (3M/16QAM)		
Date of Test	2015/07/09	Test Site	AC6

Figure Channel 26705 (815.50MHz)
1RB0

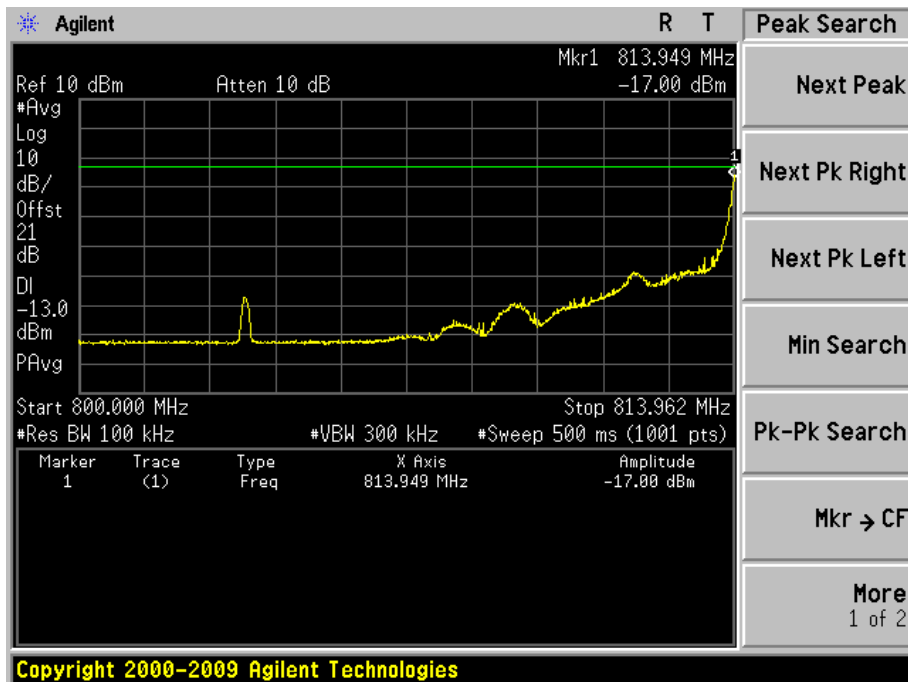
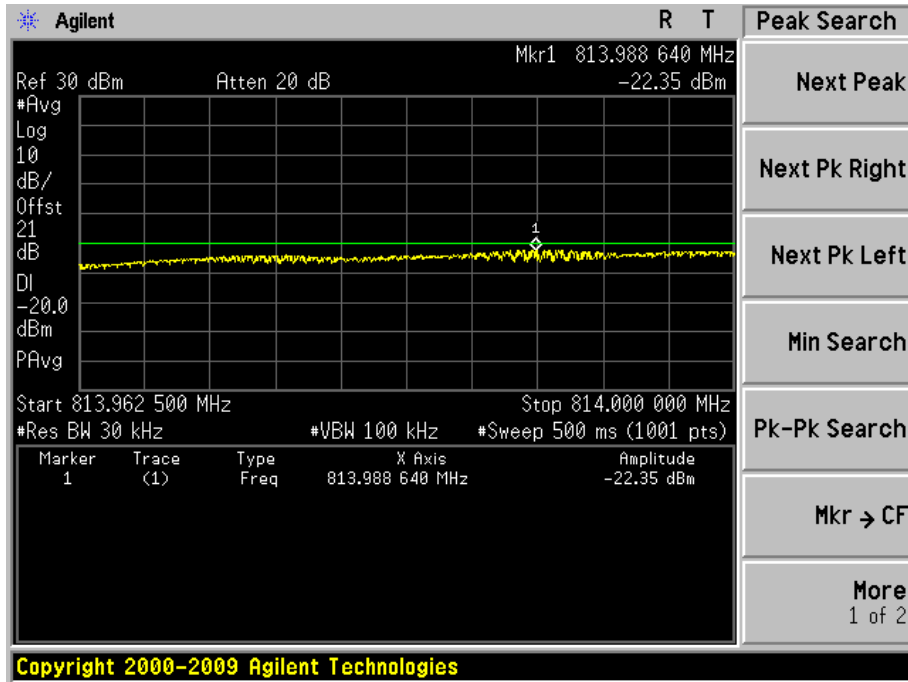

15RB0

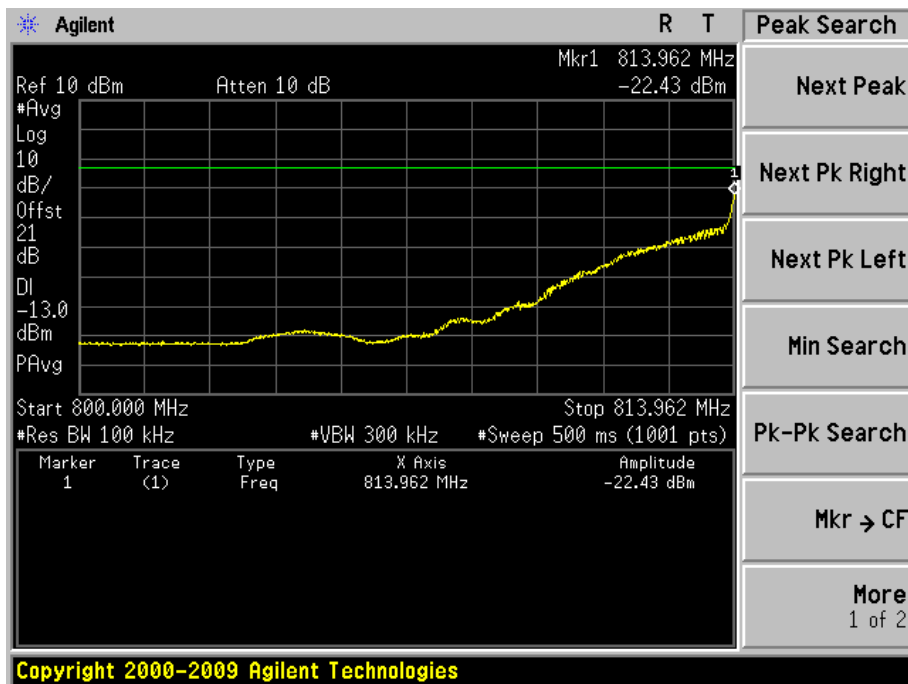
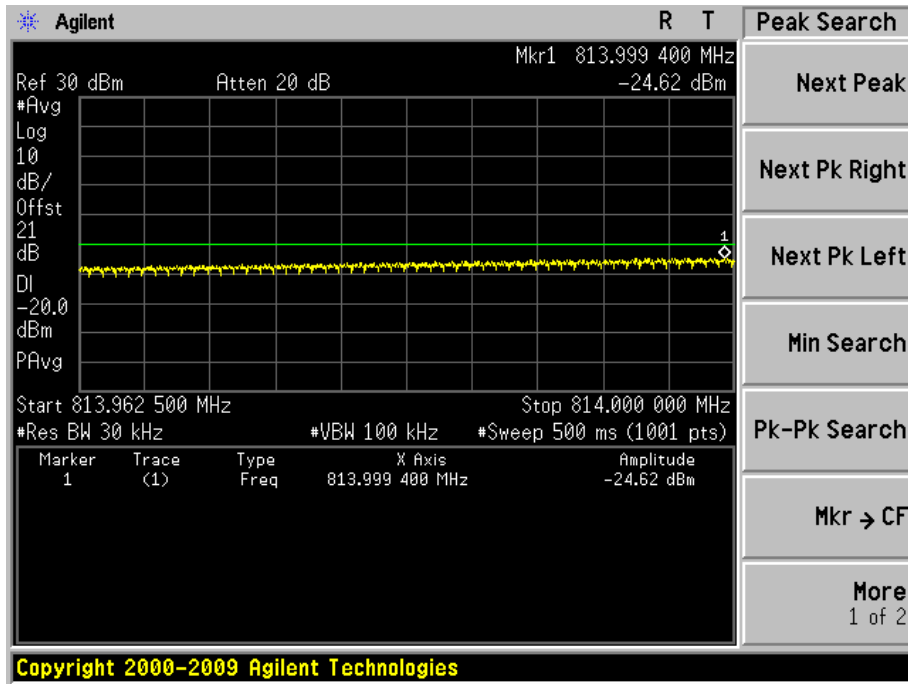
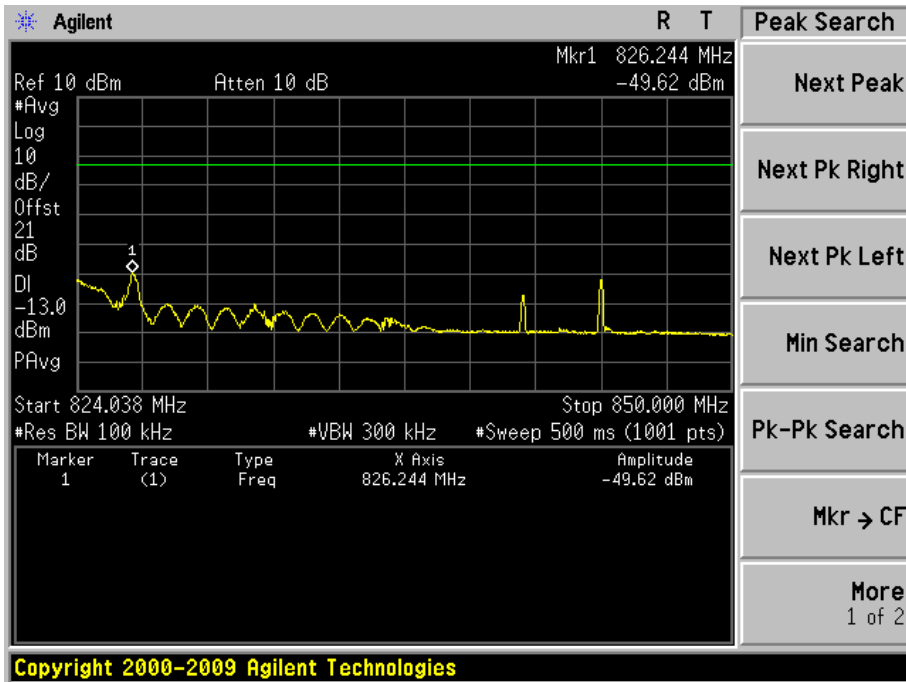
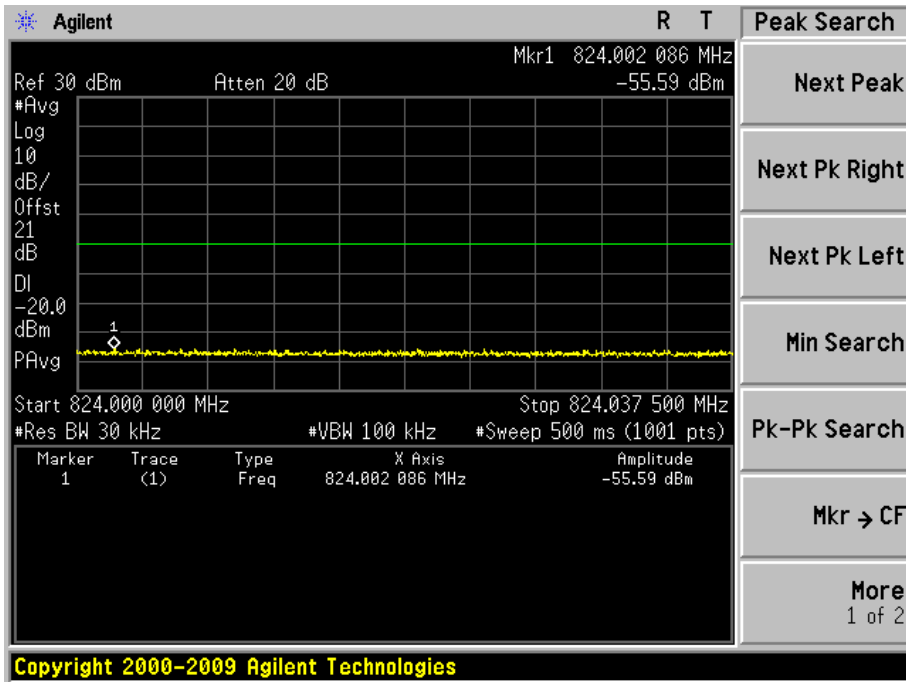
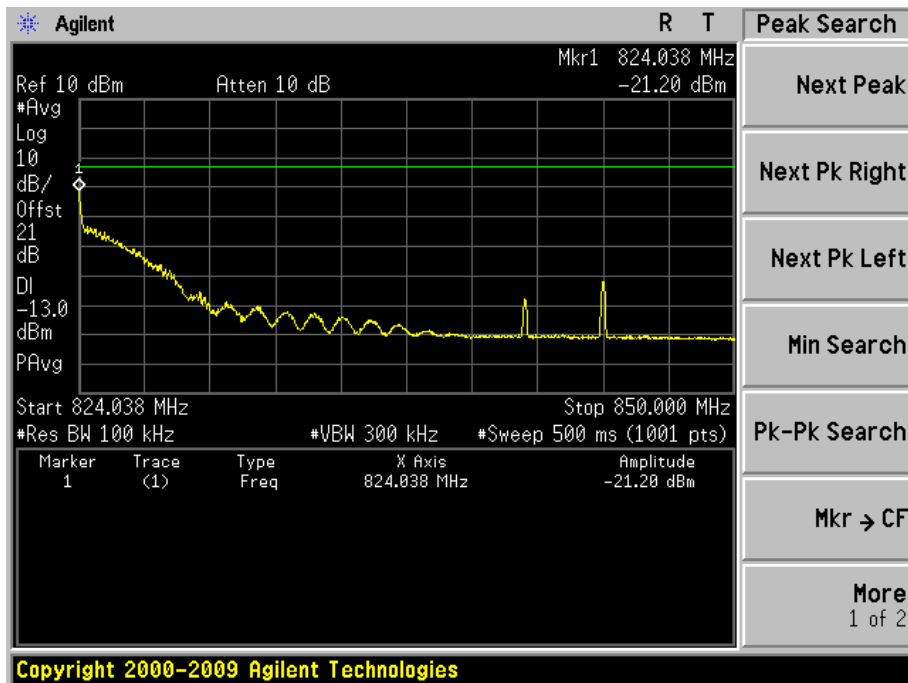
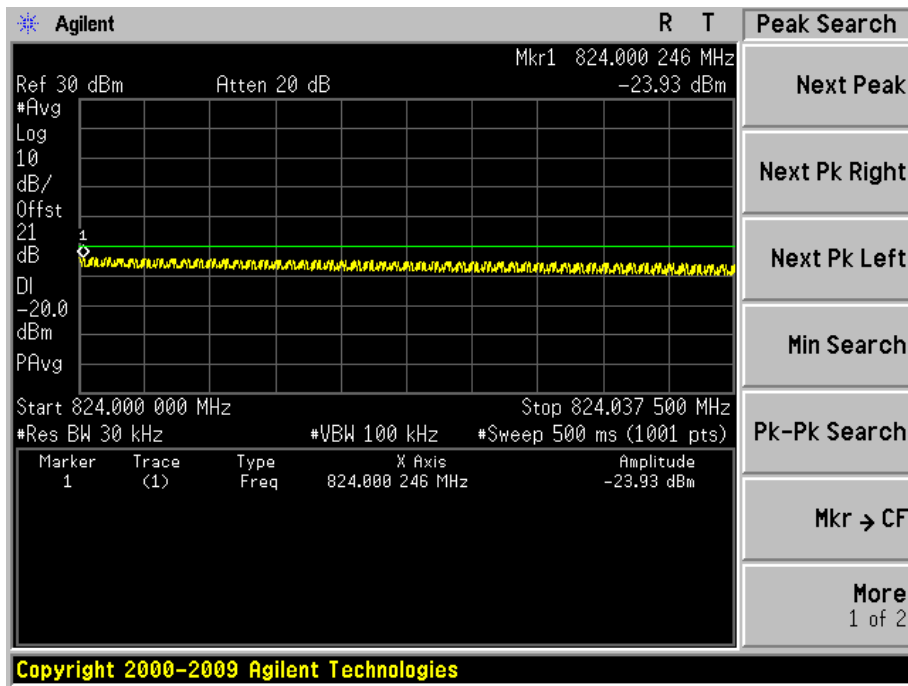

Figure Channel 26775 (822.50MHz)

1RB14



15RB0



Product	Wireless Module		
Test Item	Conducted Band Edge		
Test Mode	Mode 1: LTE Band 26 (1.4M/QPSK)		
Date of Test	2015/07/09	Test Site	AC6

Figure Channel 26697 (814.70MHz)
1RB0

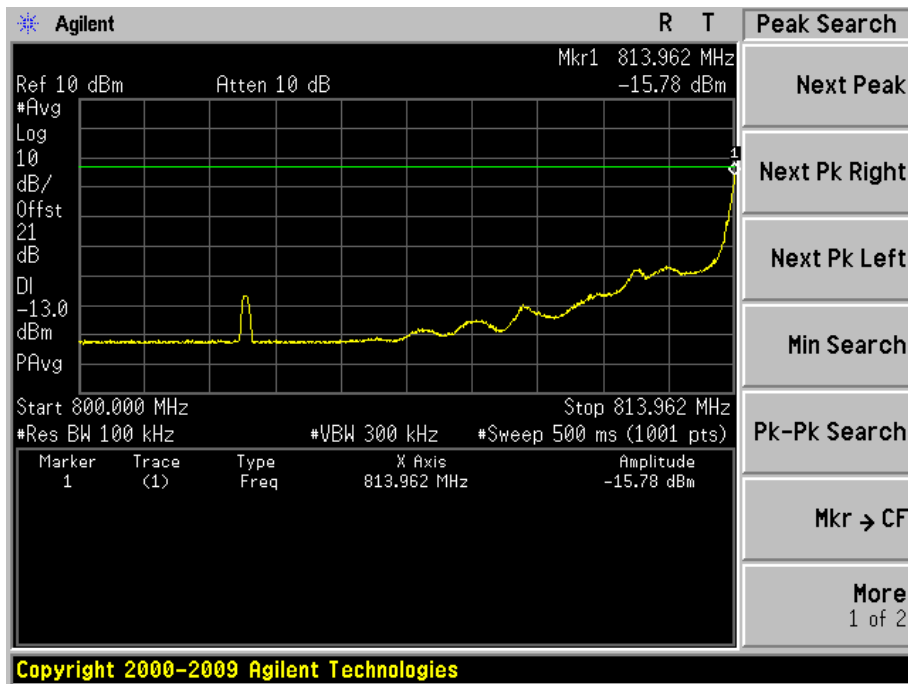
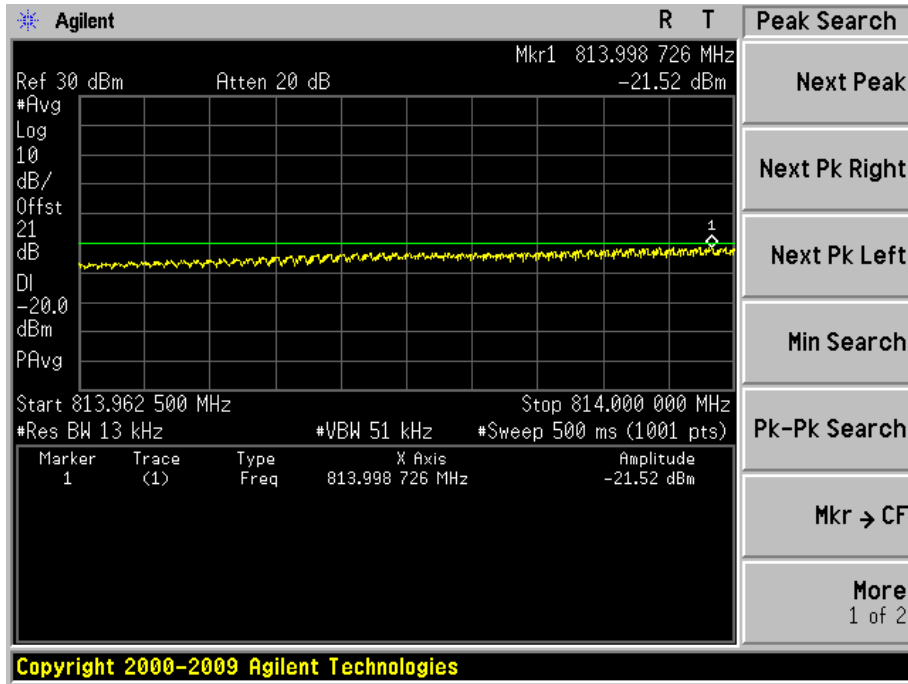

7RB0

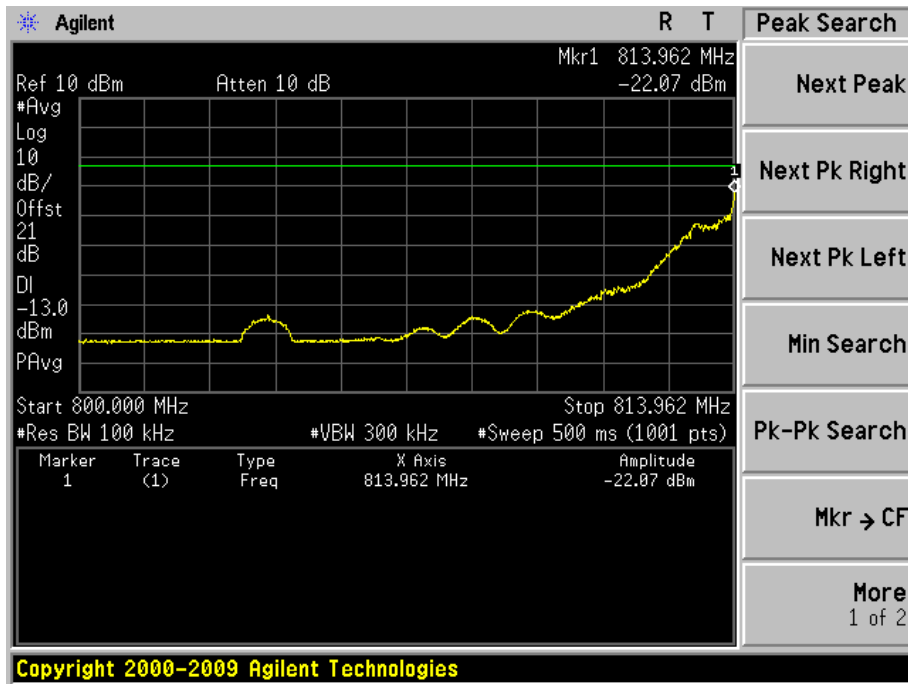
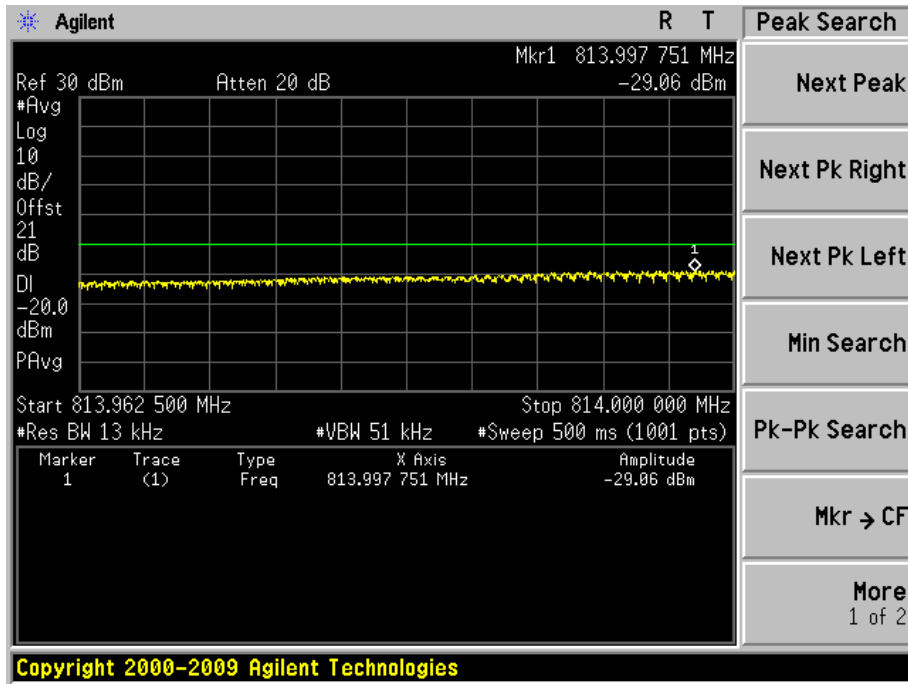
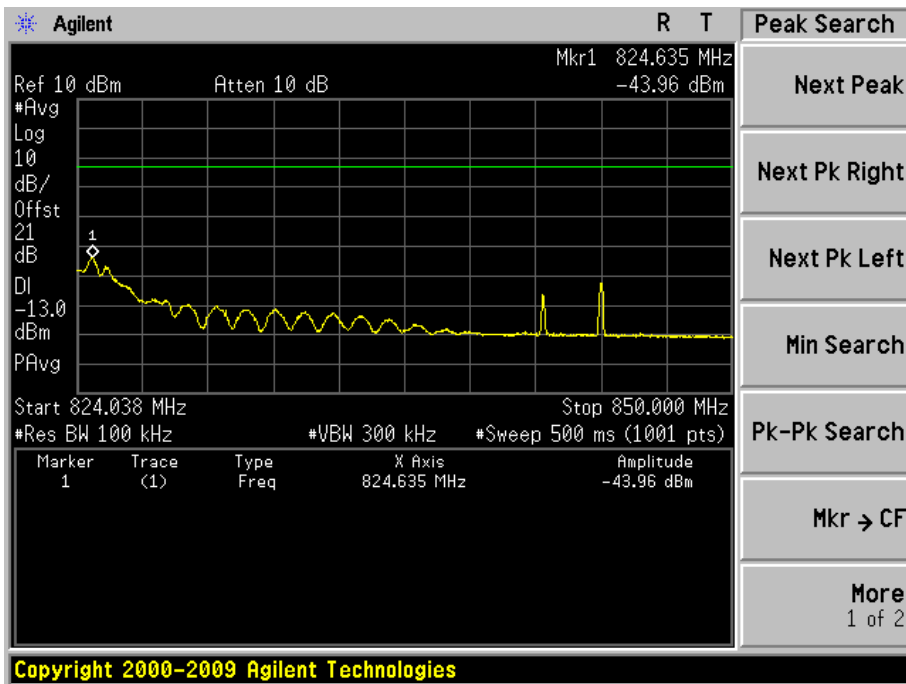
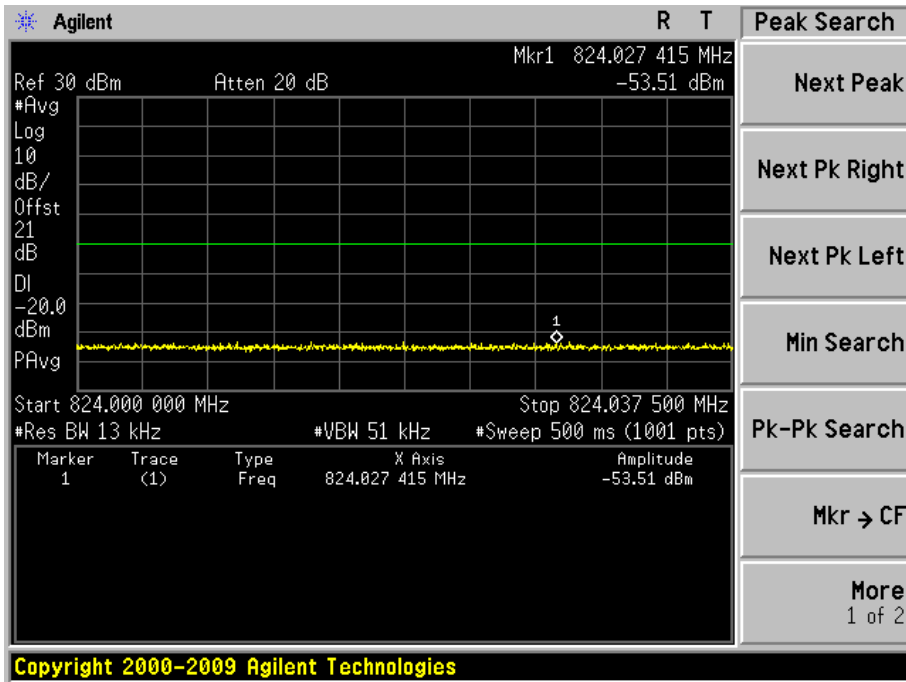
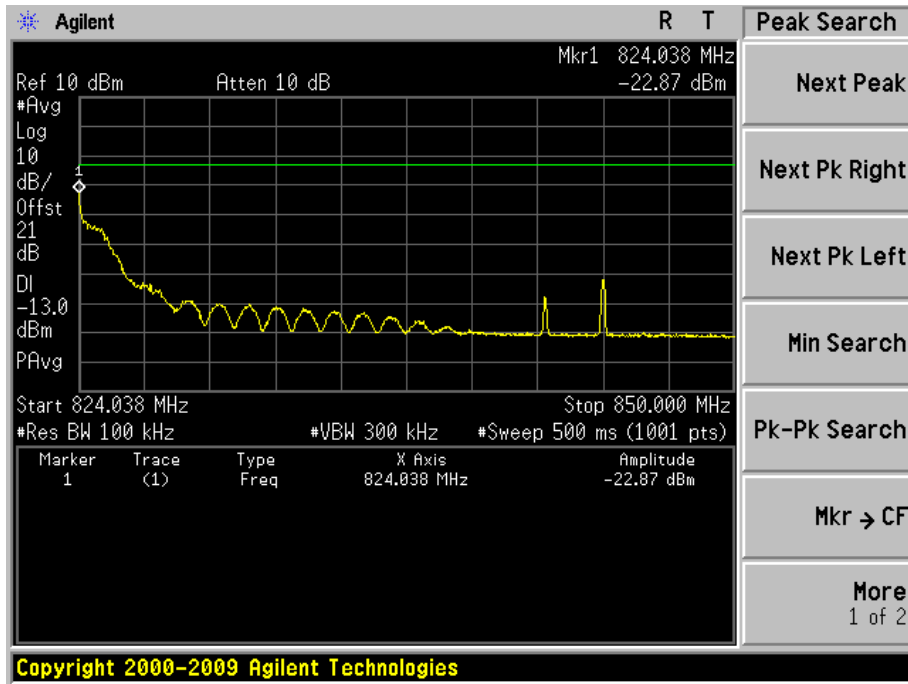
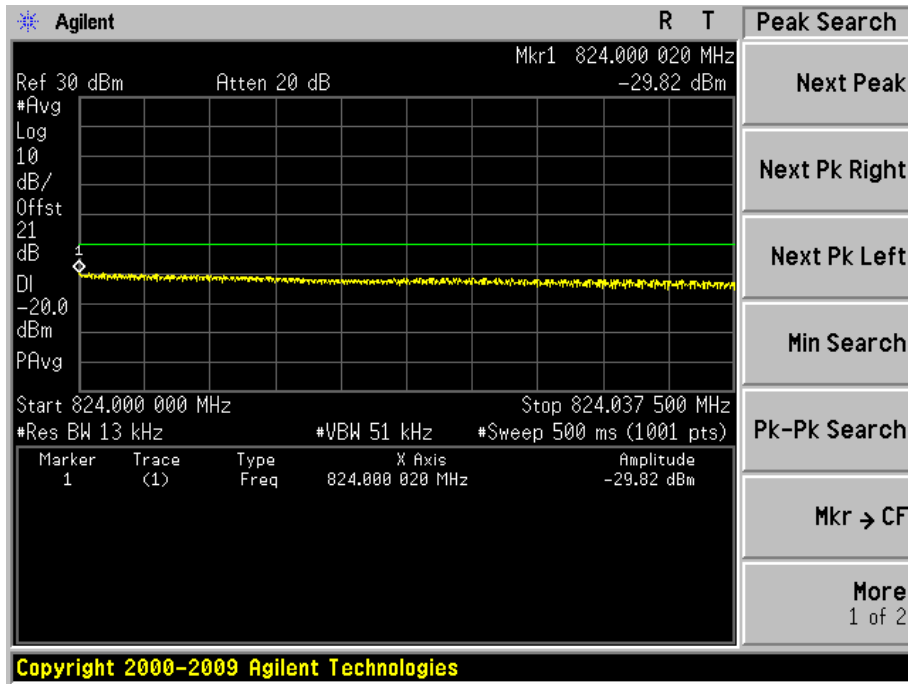

Figure Channel 26783 (823.30MHz)

1RB6



7RB0



Product	Wireless Module		
Test Item	Conducted Band Edge		
Test Mode	Mode 1: LTE Band 26 (1.4M/16QAM)		
Date of Test	2015/07/09	Test Site	AC6

Figure Channel 26697 (814.70MHz)

1RB0

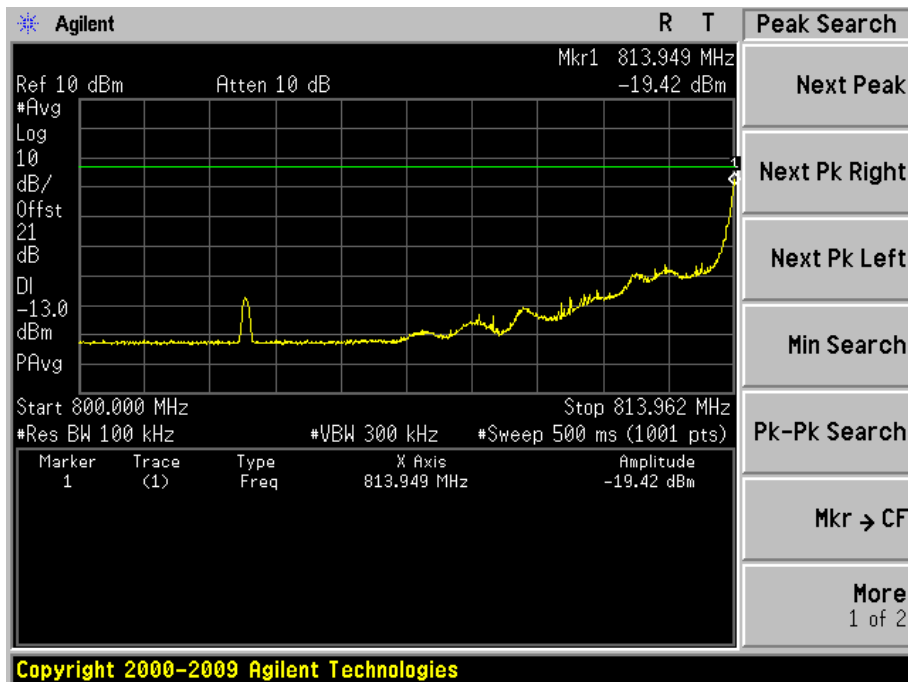
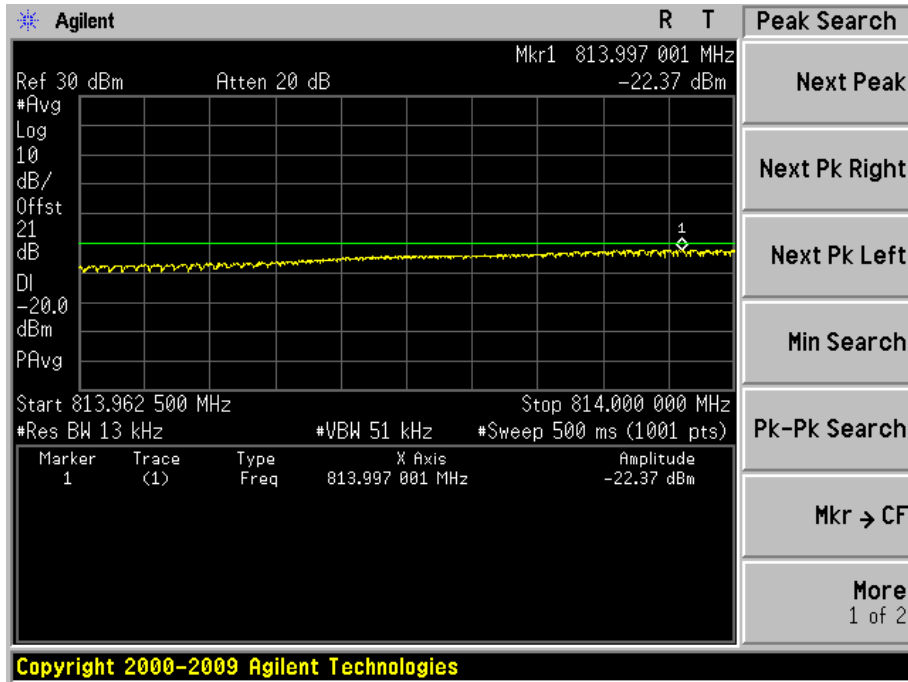

7RB0

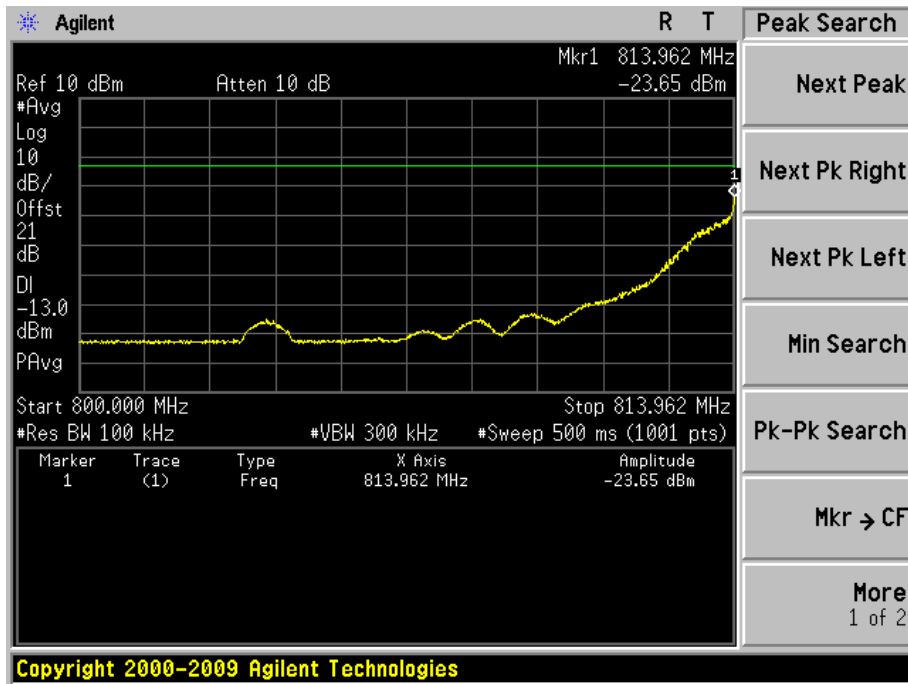
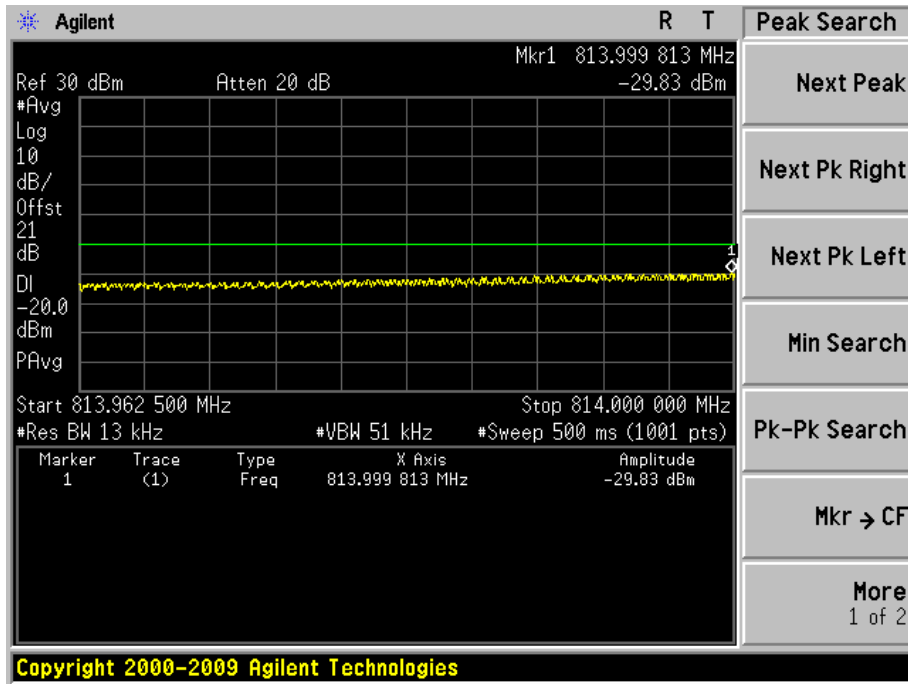
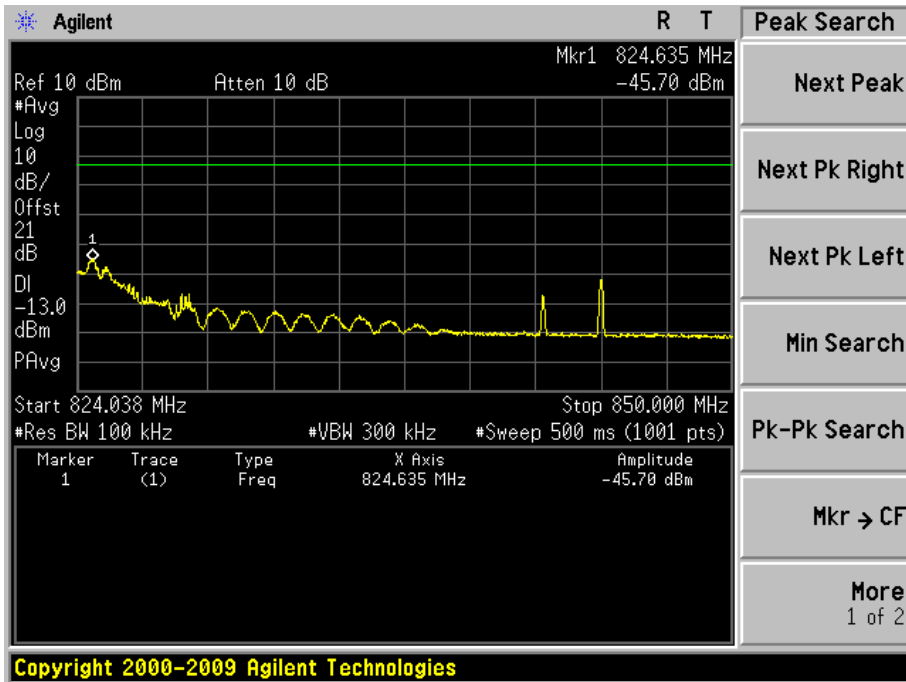
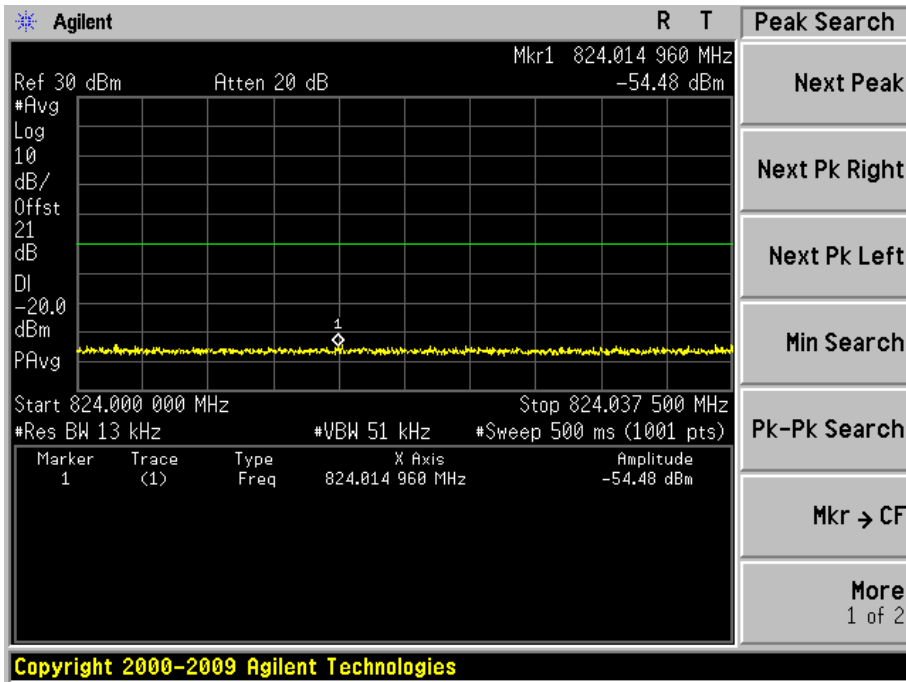
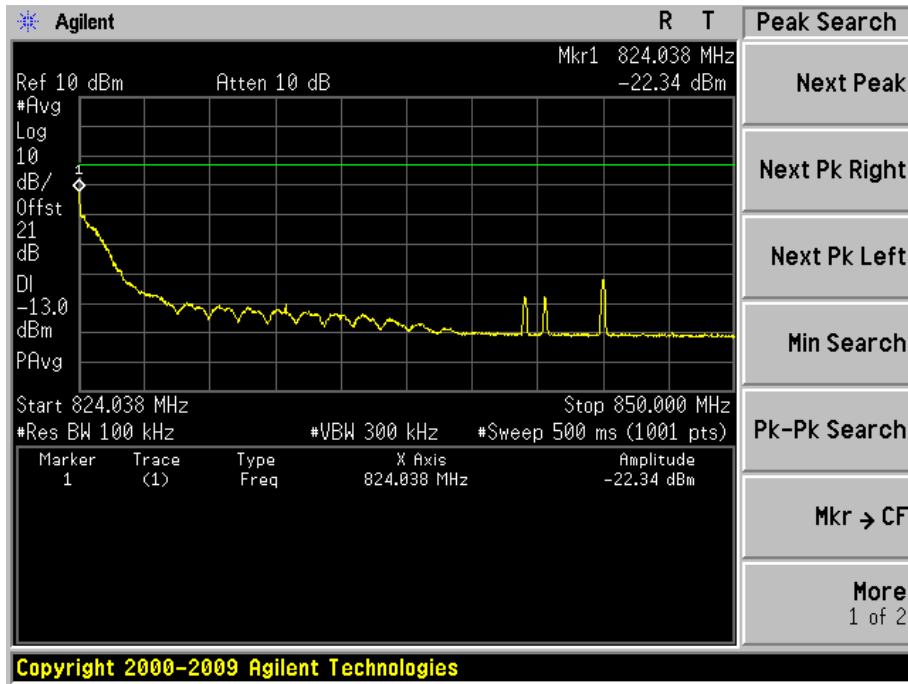
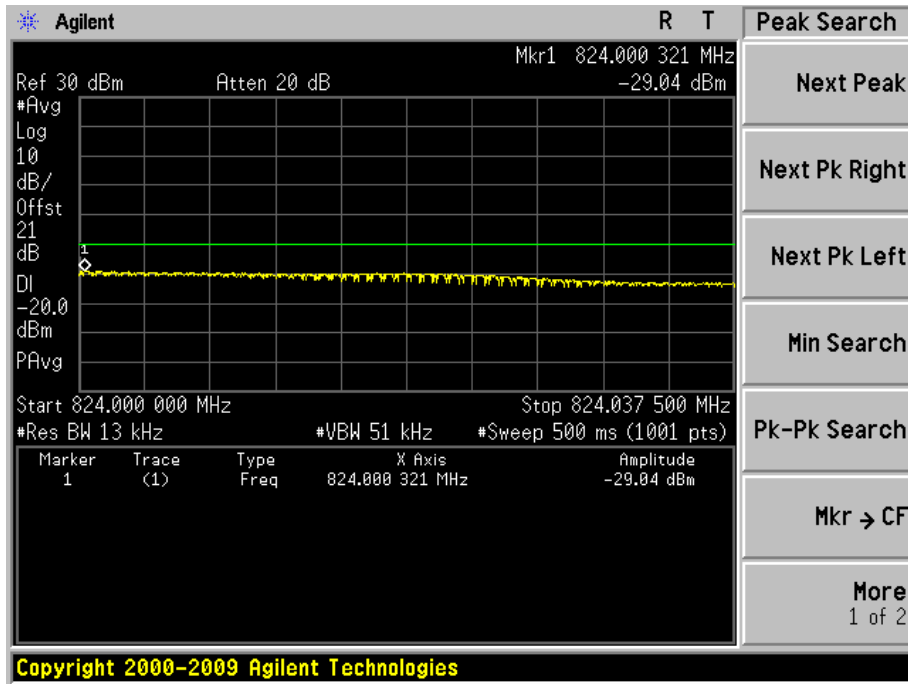

Figure Channel 26783 (823.30MHz)

1RB6



7RB0



7. Spurious Emission

7.1. Test Equipment

Conducted Emission / AC-6

Instrument	Manufacturer	Type No.	Serial No	Cali. Due Date
PSA Series Spectrum Analyzer	Agilent	E4440A	MY49420184	2016/03/10
Radio Communication Tester	R&S	CMU 200	117088	2016/03/10
Dual Directional Coupler	Agilent	778D	20160	2016/03/10
10dB Coaxial Coupler	Agilent	87300C	MY44300299	2016/03/10
Temperature/Humidity Meter	Zhicheng	ZC1-2	AC6-TH	2016/01/07

Radiated Spurious Emission / AC-5

Instrument	Manufacturer	Type No.	Serial No	Cali. Due Date
EMI Receiver	Agilent	N9038A	MY51210196	2015/08/07
Radio Communication Tester	R&S	CMU 200	117088	2016/03/10
PSG Analog Signal Generator	Agilent	E8257D	MY44321116	2016/03/10
Preamplifier	QuieTek	AP-025C	CHM-0503006	2016/04/11
Preamplifier	Miteq	NSP1800-25	1364185	2016/05/03
DRG Horn	ETS-Lindgren	3117	00123988	2016/01/07
Broad-Band Horn Antenna	Schwarzbeck	BBHA9120D	737	2016/03/01
Coaxial Cable	Huber+Suhner	SUCOFLEX 106	AC5-C1	2016/03/01
Coaxial Cable	Huber+Suhner	SUCOFLEX 106	AC5-C2	2016/03/01
Coaxial Cable	Huber+Suhner	SUCOFLEX 102	AC5-C3	2016/03/10
EMI Receiver	Agilent	N9038A	MY51210196	2016/01/07
Temperature/Humidity Meter	Zhichen	ZC1-2	AC5-TH	2016/01/07

7.2. Test Setup

Conducted Spurious Measurement: below 1GHz

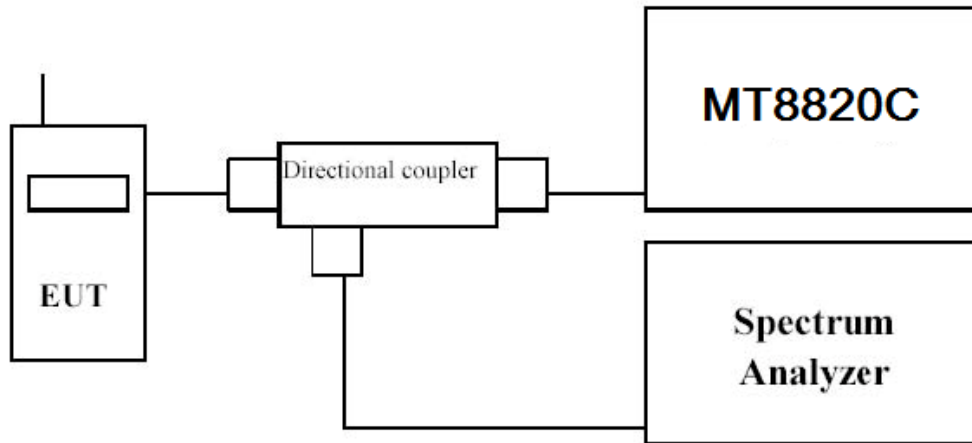

Radiated Spurious Measurement: below 1GHz

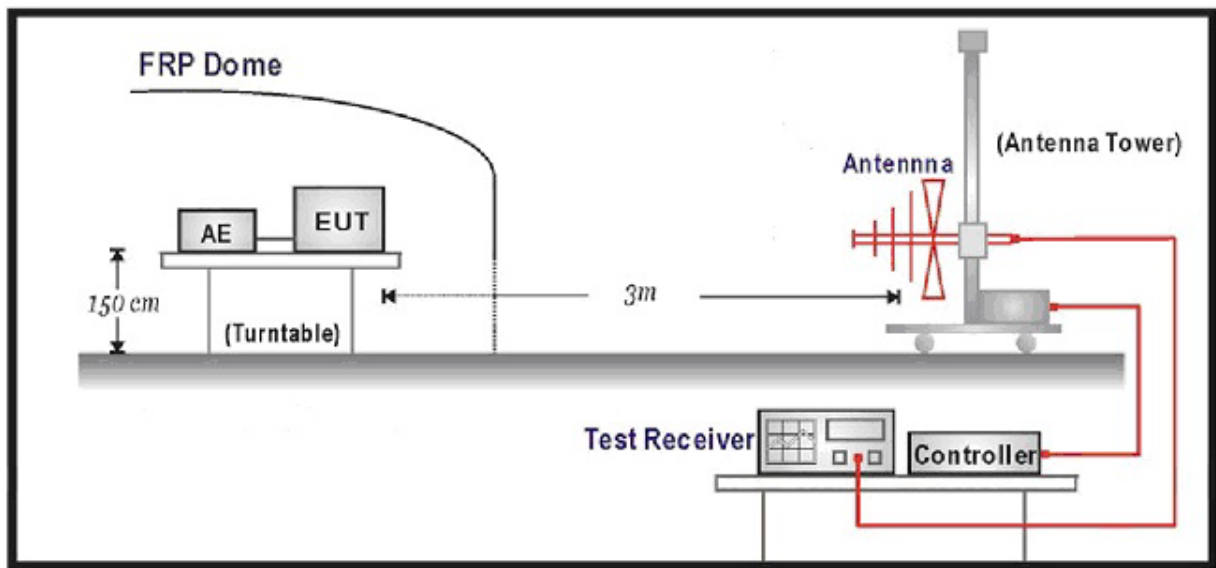

Radiated Spurious Measurement: above 1GHz

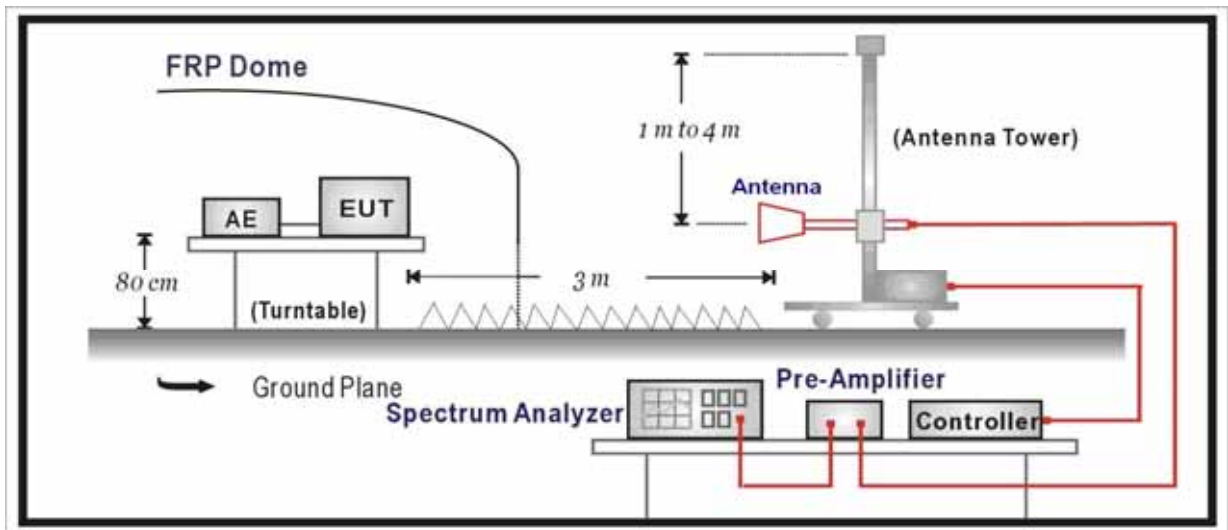

7.3. Test Procedure

Conducted Spurious Measurement:

- a) The EUT was connected to spectrum analyzer and System Simulator via power divider.
- b) The RF output of EUT was connected to the spectrum analyzer by RF cable and attenuator.
The path loss was compensated to the results for each measurement.
- c) The conducted spurious emission for the whole frequency range was taken.

Radiated Spurious Measurement:

- d) The EUT was placed on a rotatable wooden table with 1.5 meter above ground.
- e) The EUT was set 3 meters from the receiving antenna, which was mounted on the antenna tower.
- f) The table was rotated 360 degrees to determine the position of the highest spurious emission.
- g) The height of the receiving antenna is varied between one meter and four meters to search the maximum spurious emission for both horizontal and vertical polarizations.
- h) Make the measurement with the spectrum analyzer's RBW = 1MHz, VBW = 1MHz, Sweep 500ms, Taking the record of maximum spurious emission.
- i) A horn antenna was substituted in place of the EUT and was driven by a signal generator.
- j) Tune the output power of signal generator to the same emission level with EUT maximum spurious emission.
- k) Taking the record of output power at antenna port
- l) Repeat step 7 to step 8 for another polarization.
- m) $EIRP = SG - \text{Cable loss} + \text{Antenna Gain}$

7.4. Uncertainty

The measurement uncertainty is defined as 3.2 dB for Radiated Power Measurement.

7.5. Test Result

LTE Band 26 for Part 22H

Product	Wireless Module		
Test Item	Conducted Spurious Emission		
Test Mode	Mode 1: LTE Band 26 (10M/QPSK)		
Date of Test	2015/07/09	Test Site	TR8

Low Channel 26840(829.00MHz) 1RB0

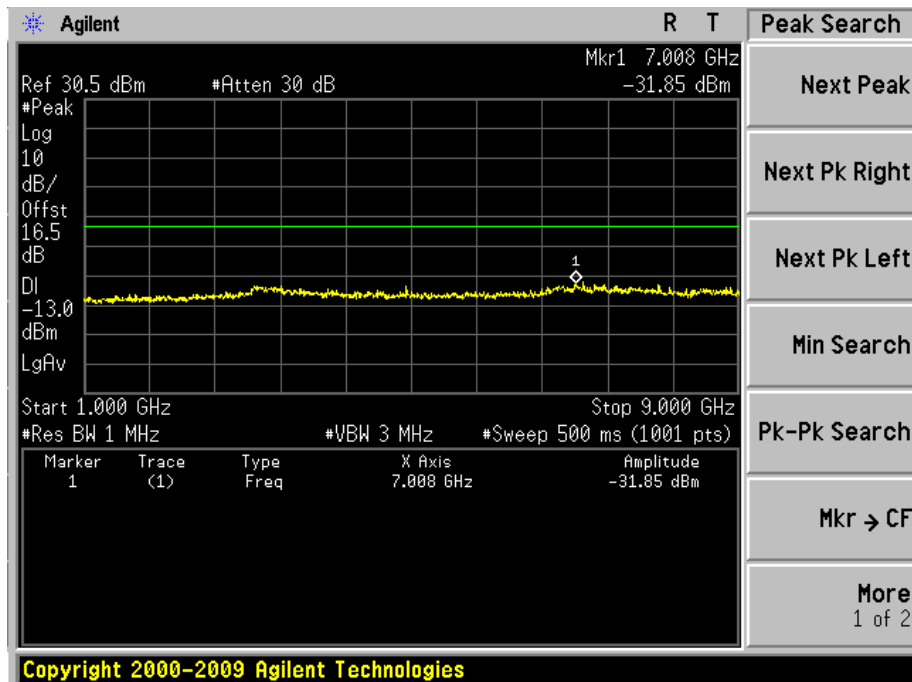
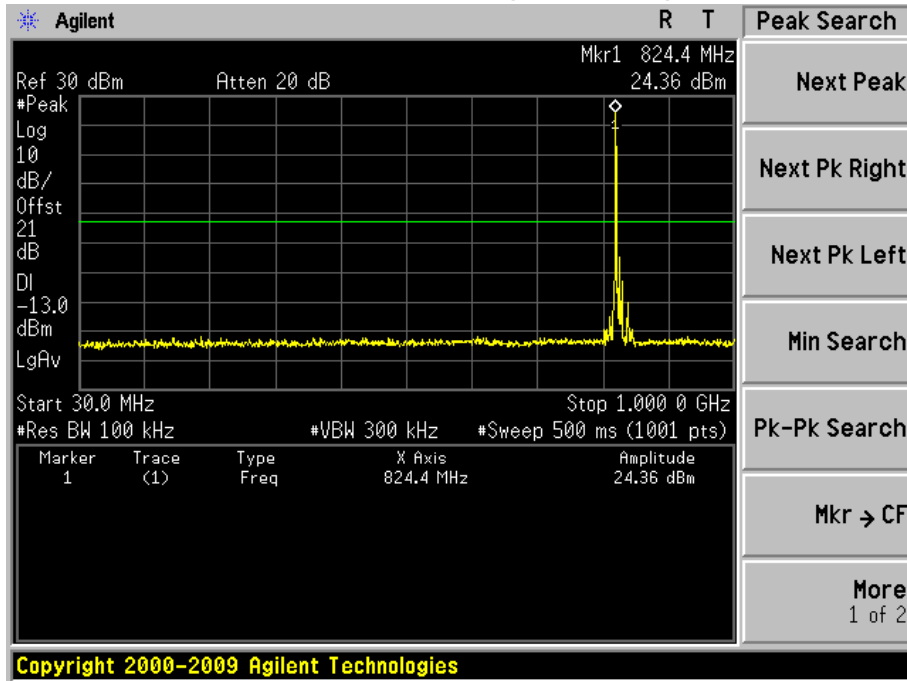

Mid Channel 26915(836.50MHz) 1RB0

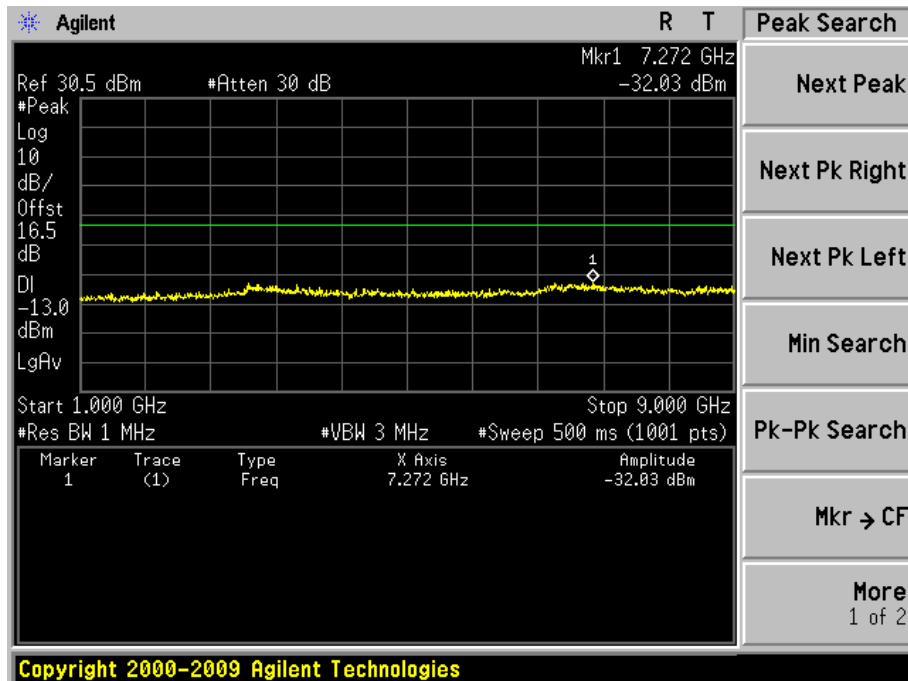
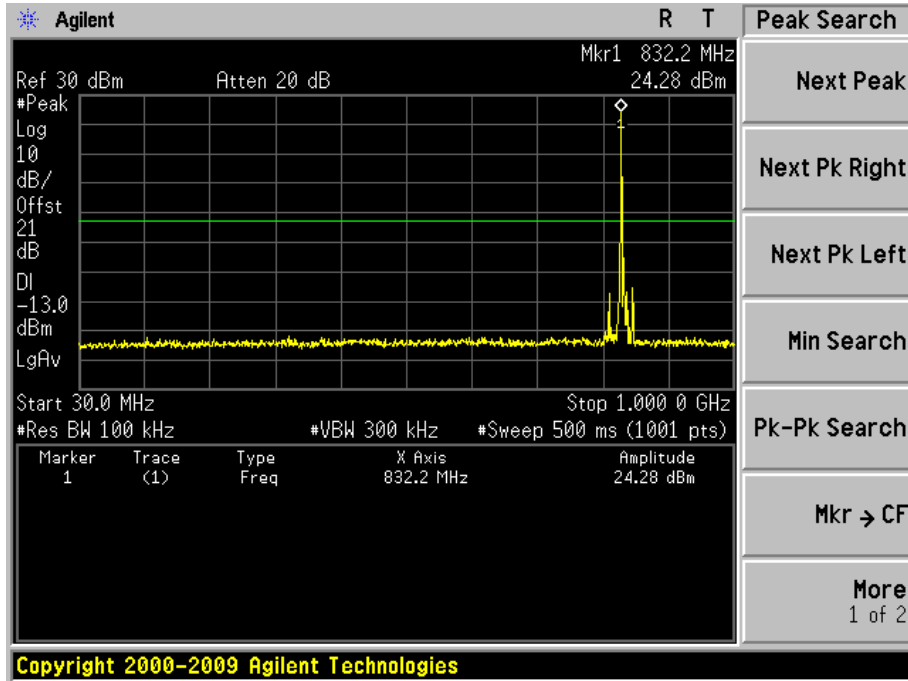

High Channel 26990(844.00MHz) 1RB0

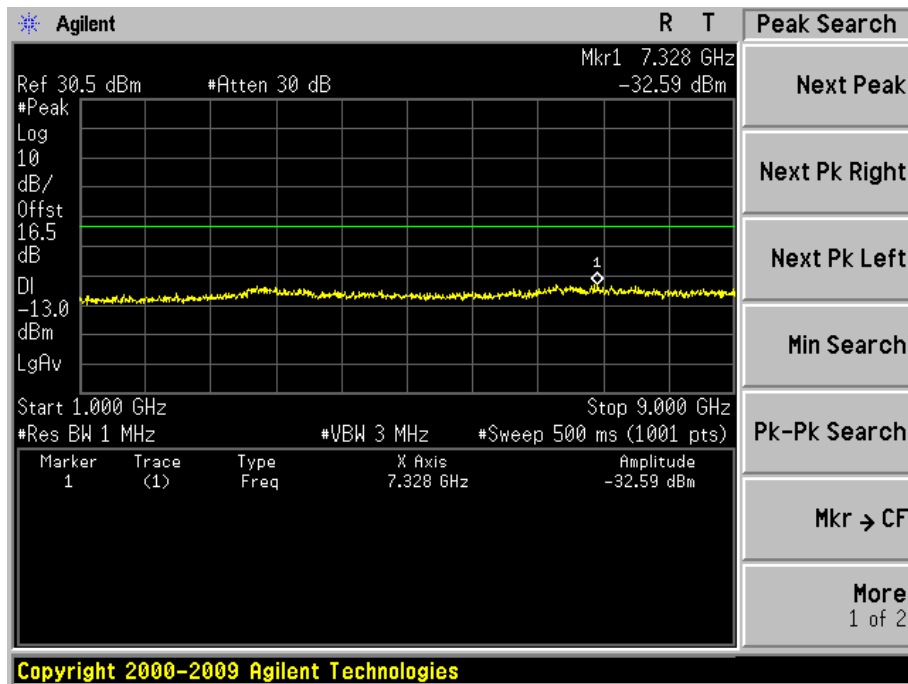
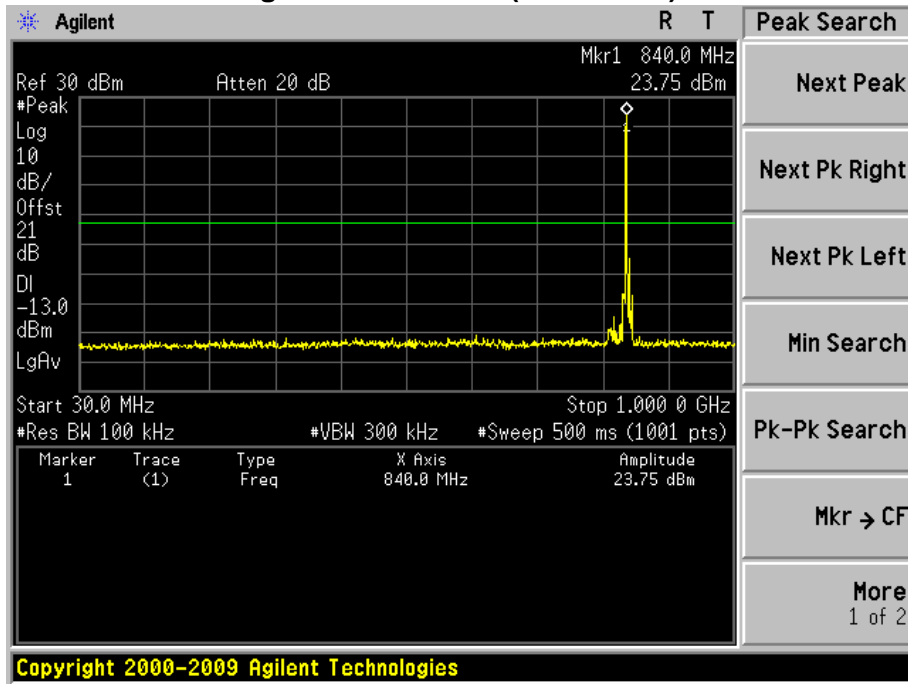

Product	Wireless Module		
Test Item	Conducted Spurious Emission		
Test Mode	Mode 1: LTE Band 26 (10M/16QAM)		
Date of Test	2015/07/09	Test Site	TR8

Low Channel 26840(829.00MHz) 1RB0

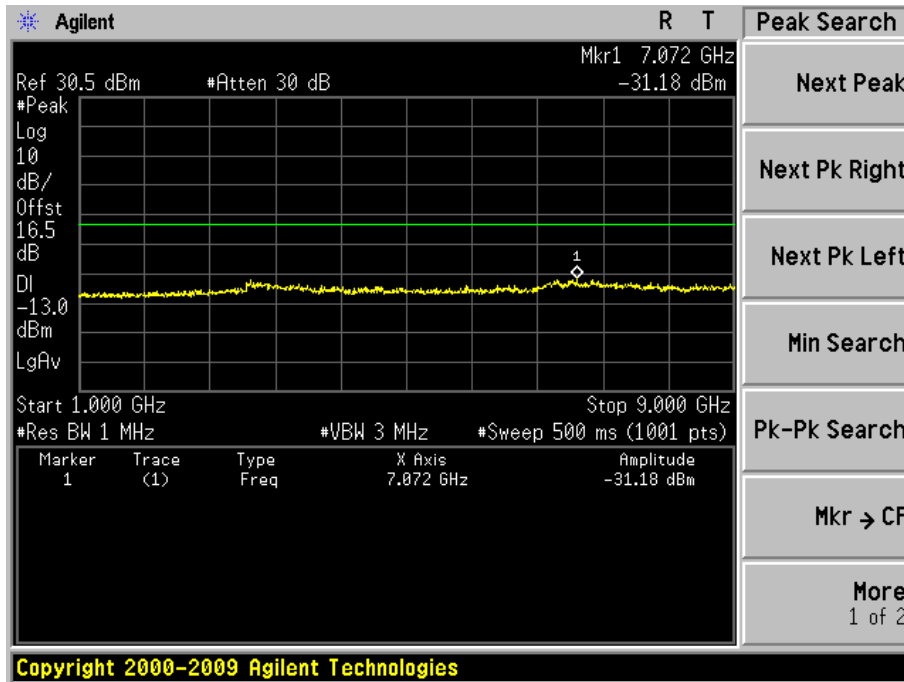
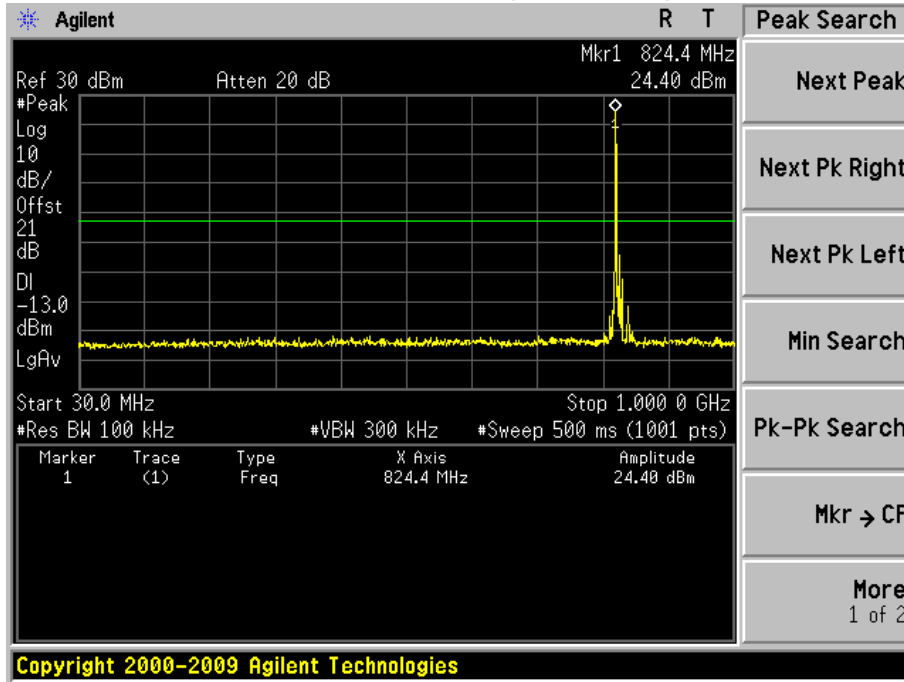

Mid Channel 26915(836.50MHz) 1RB0

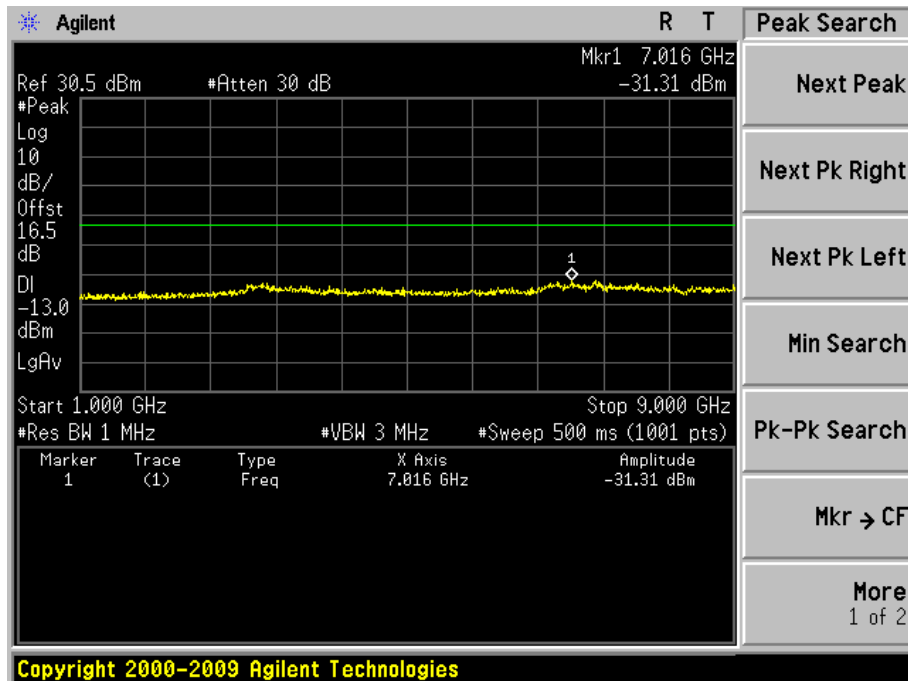
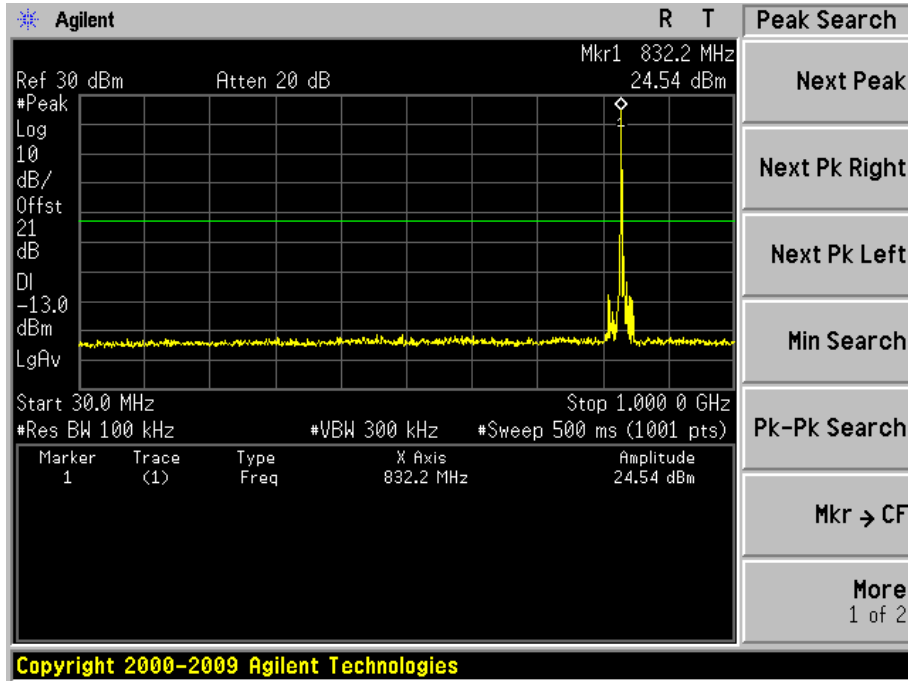

LTE Band 26 For Part 90S

Product	Wireless Module		
Test Item	Conducted Spurious Emission		
Test Mode	Mode 1: LTE Band 26 (10M/16QAM)		
Date of Test	2015/07/09	Test Site	TR8

Low Channel 26740(819.00MHz) 1RB0

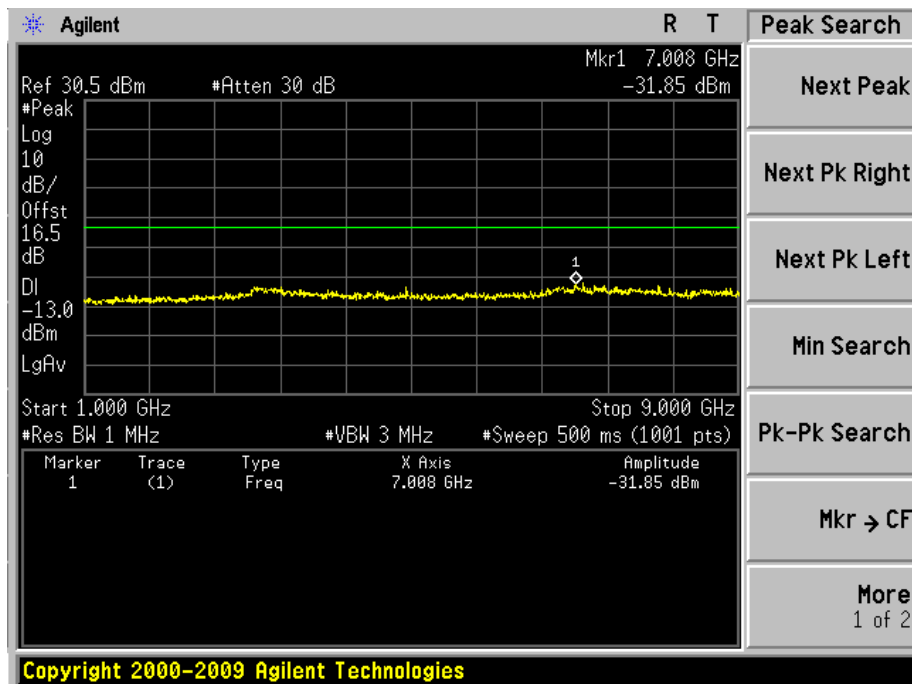
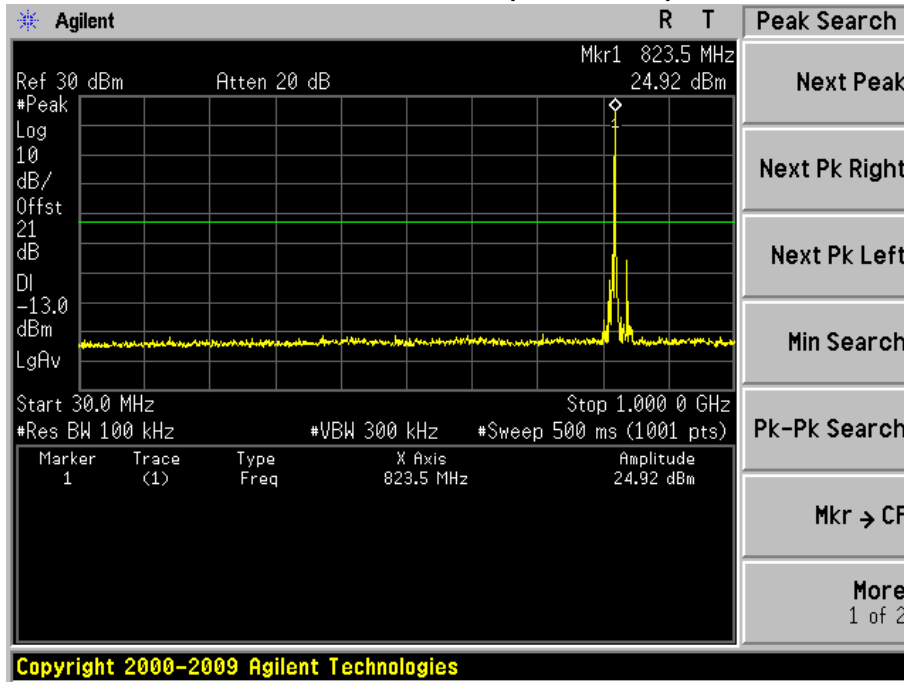

Product	Wireless Module		
Test Item	Conducted Spurious Emission		
Test Mode	Mode 1: LTE Band 26 (10M/16QAM)		
Date of Test	2015/07/09	Test Site	TR8

Low Channel 26740(819.00MHz) 1RB0

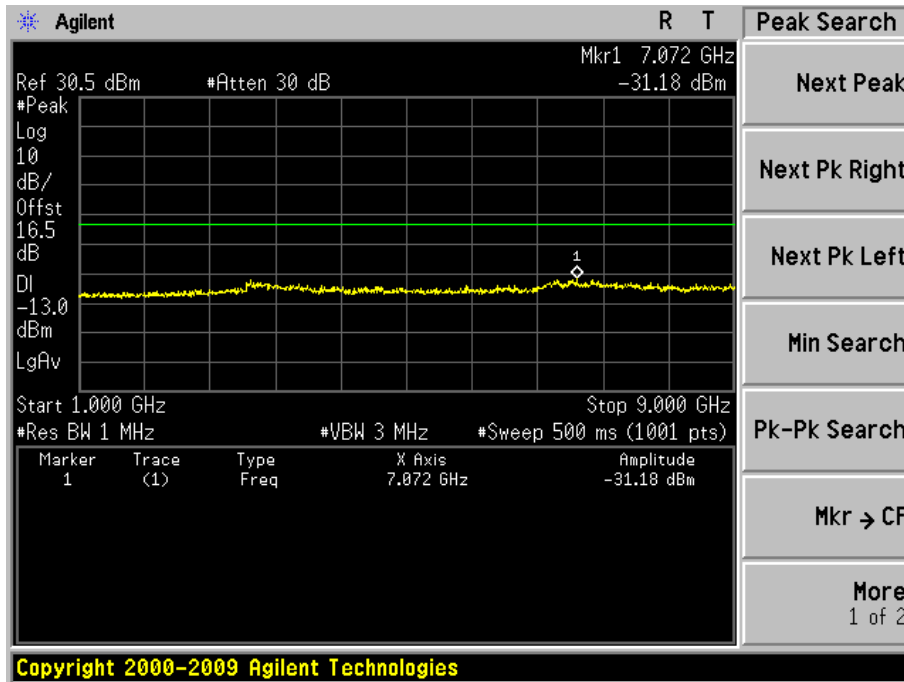
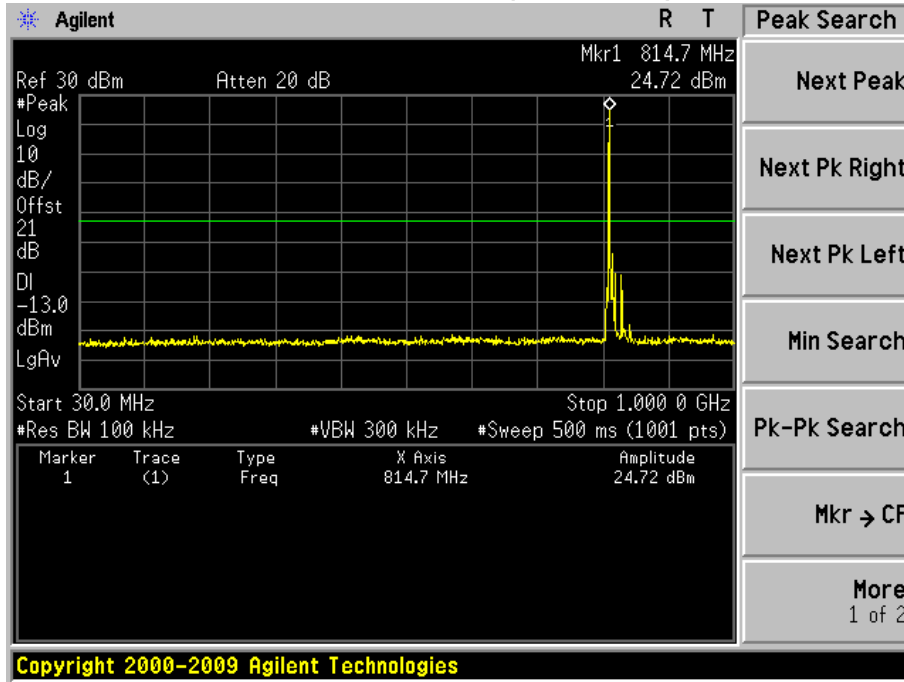

LTE Band 26 For Part 22H

Product	Wireless Module		
Test Item	Radiated Spurious Emission		
Test Mode	Mode 1: LTE Band 26 (10M/QPSK)		
Date of Test	2015/07/09	Test Site	AC-5

Frequency (MHz)	SA Reading (dBm)	Ant.Pol. (H/V)	SG Reading (dBm)	Cable Loss (dB)	Gain (dBi)	EIRP (dBm)	Limit (dBm)	Margin (dB)
Low Channel 26840 (829.00MHz) 1RB0								
1658.00	-61.37	V	-65.30	1.03	9.73	-56.60	-13.00	-43.60
2487.00	-63.79	V	-64.63	1.30	10.45	-55.48	-13.00	-42.48
1658.00	-63.38	H	-67.35	1.03	9.73	-58.65	-13.00	-45.65
2487.00	-64.14	H	-65.28	1.30	10.45	-56.13	-13.00	-43.13
Middle Channel 26915 (836.50MHz) 1RB0								
1673.00	-61.38	V	-64.27	1.05	9.89	-55.43	-13.00	-42.43
2509.50	-63.79	V	-64.79	1.31	10.58	-55.52	-13.00	-42.52
1673.00	-63.39	H	-66.01	1.05	9.89	-57.17	-13.00	-44.17
2509.50	-64.14	H	-65.54	1.31	10.58	-56.27	-13.00	-43.27
High Channel 26990 (844.00MHz) 1RB0								
1688.00	-62.50	V	-66.18	1.02	10.04	-57.16	-13.00	-44.16
2532.00	-64.29	V	-64.68	1.28	10.65	-55.31	-13.00	-42.31
1688.00	-62.78	H	-67.02	1.02	10.04	-58.00	-13.00	-45.00
2532.00	-64.64	H	-65.33	1.28	10.65	-55.96	-13.00	-42.96

Product	Wireless Module		
Test Item	Radiated Spurious Emission		
Test Mode	Mode 1: LTE Band 26 (10M/16QAM)		
Date of Test	2015/07/09	Test Site	AC-5

Frequency (MHz)	SA Reading (dBm)	Ant.Pol. (H/V)	SG Reading (dBm)	Cable Loss (dB)	Gain (dBi)	EIRP (dBm)	Limit (dBm)	Margin (dB)
Low Channel 26840 (829.00MHz) 1RB0								
1658.00	-61.36	V	-66.03	1.03	9.73	-57.33	-13.00	-44.33
2487.00	-63.78	V	-65.44	1.30	10.45	-56.29	-13.00	-43.29
1658.00	-63.40	H	-64.90	1.03	9.73	-56.20	-13.00	-43.20
2487.00	-64.15	H	-65.06	1.30	10.45	-55.91	-13.00	-42.91
Middle Channel 26915 (836.50MHz) 1RB0								
1673.00	-61.37	V	-64.99	1.05	9.89	-56.15	-13.00	-43.15
2509.50	-63.79	V	-64.36	1.31	10.58	-55.09	-13.00	-42.09
1673.00	-63.39	H	-65.89	1.05	9.89	-57.05	-13.00	-44.05
2509.50	-64.15	H	-64.91	1.31	10.58	-55.64	-13.00	-42.64
High Channel 26990 (844.00MHz) 1RB0								
1688.00	-62.63	V	-66.31	1.02	10.04	-57.29	-13.00	-44.29
2532.00	-64.11	V	-64.50	1.28	10.65	-55.13	-13.00	-42.13
1688.00	-62.95	H	-67.19	1.02	10.04	-58.17	-13.00	-45.17
2532.00	-64.90	H	-65.60	1.28	10.65	-56.23	-13.00	-43.23

LTE Band 26 For Part 90S

Product	Wireless Module		
Test Item	Radiated Spurious Emission		
Test Mode	Mode 1: LTE Band 26 (10M/QPSK)		
Date of Test	2015/07/09	Test Site	AC-5

Frequency (MHz)	SA Reading (dBm)	Ant.Pol. (H/V)	SG Reading (dBm)	Cable Loss (dB)	Gain (dBi)	EIRP (dBm)	Limit (dBm)	Margin (dB)
Low Channel 26740 (819.00MHz) 1RB0								
1638.00	-61.94	V	-65.87	1.00	9.70	-57.17	-13.00	-44.17
2457.00	-64.35	V	-65.19	1.27	10.42	-56.04	-13.00	-43.04
1638.00	-63.97	H	-67.94	1.00	9.70	-59.24	-13.00	-46.24
2457.00	-64.71	H	-65.85	1.27	10.42	-56.70	-13.00	-43.70

Product	Wireless Module		
Test Item	Radiated Spurious Emission		
Test Mode	Mode 1: LTE Band 26 (10M/16QAM)		
Date of Test	2015/07/09	Test Site	AC-5

Frequency (MHz)	SA Reading (dBm)	Ant.Pol. (H/V)	SG Reading (dBm)	Cable Loss (dB)	Gain (dBi)	EIRP (dBm)	Limit (dBm)	Margin (dB)
Low Channel 26840 (819.00MHz) 1RB0								
1638.00	-62.67	V	-66.61	1.00	9.70	-57.91	-13.00	-44.91
2457.00	-65.17	V	-66.01	1.27	10.42	-56.86	-13.00	-43.86
1638.00	-61.50	H	-65.47	1.00	9.70	-56.77	-13.00	-43.77
2457.00	-64.48	H	-65.62	1.27	10.42	-56.47	-13.00	-43.47

8. Frequency Stability Under Temperature & Voltage Variations

8.1. Test Equipment

Frequency Stability Under Temperature & Voltage Variations / TR-7

Instrument	Manufacturer	Type No.	Serial No	Cali. Due Date
PSA Series Spectrum Analyzer	Agilent	E4440A	MY49420184	2016/03/10
Radio Communication Tester	R&S	CMU 200	117088	2016/03/10
Dual Directional Coupler	Agilent	778D	20160	2016/03/10
10dB Coaxial Coupler	Agilent	87300C	MY44300299	2016/03/10
DC Power Supply	IDRC	CD-035-020PR	977272	2016/03/10
Temperature & Humidity Chamber	Gaoyu	TH-1P-B	WIT-05121302	2016/01/07
Temperature/Humidity Meter	Zhicheng	ZC1-2	AC6-TH	2016/01/07

8.2. Test Setup

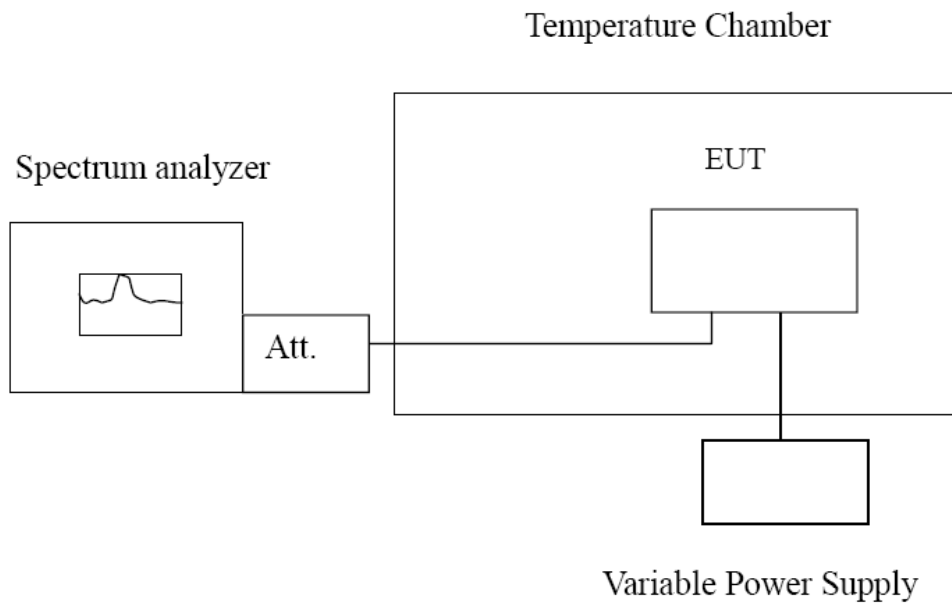

8.3. Test Procedure

Frequency Stability Under Temperature Variations:

The equipment under test was connected to an external AC or DC power supply and input rated voltage. RF output was connected to a frequency counter or spectrum analyzer via feed through attenuators. The EUT was placed inside the temperature chamber. Set the spectrum analyzer RBW low enough to obtain the desired frequency resolution and measure EUT 20°C operating frequency as reference frequency. Turn EUT off and set the chamber temperature to -30°C. After the temperature stabilized for approximately 30 minutes recorded the frequency. Repeat step measure with 10°C increased per stage until the highest temperature of +50°C reached.

Frequency Stability Under Voltage Variations:

Set chamber temperature to 20°C. Use a variable AC power supply / DC power source to power the EUT and set the voltage to rated voltage. Set the spectrum analyzer RBW low enough to obtain the desired frequency resolution and recorded the frequency.

Reduce the input voltage to specify extreme voltage variation ($\pm 15\%$) and endpoint, record the maximum frequency change.

8.4. Uncertainty

The measurement uncertainty is defined as ± 10 Hz.

8.5. Test Result

LTE Band 26 for Part 22H

Product	Wireless Module		
Test Item	Frequency Stability Under Temperature & Voltage Variations		
Test Mode	Mode 1: LTE Band 26 (15M/QPSK)		
Date of Test	2015/07/09	Test Site	TR7

Frequency Stability under Temperature

Temperature Interval (°C)	Test Frequency (MHz)	Deviation (Hz)	Limit (Hz)
-30	836.50	-32	± 2078.8
-20	836.50	58	± 2078.8
-10	836.50	42	± 2078.8
0	836.50	-40	± 2078.8
10	836.50	48	± 2078.8
20	836.50	-45	± 2078.8
30	836.50	57	± 2078.8
40	836.50	-59	± 2078.8
50	836.50	-56	± 2078.8

Frequency Stability under Voltage

DC Voltage (V)	Test Frequency (MHz)	Deviation (Hz)	Limit (Hz)
4.2	836.50	-44	± 2078.8
3.7	836.50	-39	± 2078.8
3.4	836.50	28	± 2078.8

Product	Wireless Module		
Test Item	Frequency Stability Under Temperature & Voltage Variations		
Test Mode	Mode 1: LTE Band 26 (15M/16QAM)		
Date of Test	2015/07/09	Test Site	TR7

Frequency Stability under Temperature

Temperature Interval (°C)	Test Frequency (MHz)	Deviation (Hz)	Limit (Hz)
-30	836.50	32	± 2078.8
-20	836.50	-49	± 2078.8
-10	836.50	59	± 2078.8
0	836.50	46	± 2078.8
10	836.50	-60	± 2078.8
20	836.50	-53	± 2078.8
30	836.50	32	± 2078.8
40	836.50	53	± 2078.8
50	836.50	-46	± 2078.8

Frequency Stability under Voltage

DC Voltage (V)	Test Frequency (MHz)	Deviation (Hz)	Limit (Hz)
4.2	836.50	55	± 2078.8
3.7	836.50	36	± 2078.8
3.4	836.50	56	± 2078.8

Product	Wireless Module		
Test Item	Frequency Stability Under Temperature & Voltage Variations		
Test Mode	Mode 1: LTE Band 26 (10M/QPSK)		
Date of Test	2015/07/09	Test Site	TR7

Frequency Stability under Temperature

Temperature Interval (°C)	Test Frequency (MHz)	Deviation (Hz)	Limit (Hz)
-30	836.50	-47	± 2078.8
-20	836.50	-53	± 2078.8
-10	836.50	60	± 2078.8
0	836.50	19	± 2078.8
10	836.50	-59	± 2078.8
20	836.50	37	± 2078.8
30	836.50	-52	± 2078.8
40	836.50	-27	± 2078.8
50	836.50	-51	± 2078.8

Frequency Stability under Voltage

DC Voltage (V)	Test Frequency (MHz)	Deviation (Hz)	Limit (Hz)
4.2	836.50	44	± 2078.8
3.7	836.50	-32	± 2078.8
3.4	836.50	-11	± 2078.8

Product	Wireless Module		
Test Item	Frequency Stability Under Temperature & Voltage Variations		
Test Mode	Mode 1: LTE Band 26 (10M/16QAM)		
Date of Test	2015/07/09	Test Site	TR7

Frequency Stability under Temperature

Temperature Interval (°C)	Test Frequency (MHz)	Deviation (Hz)	Limit (Hz)
-30	836.50	29	± 2078.8
-20	836.50	-32	± 2078.8
-10	836.50	-54	± 2078.8
0	836.50	46	± 2078.8
10	836.50	-52	± 2078.8
20	836.50	47	± 2078.8
30	836.50	-31	± 2078.8
40	836.50	48	± 2078.8
50	836.50	38	± 2078.8

Frequency Stability under Voltage

DC Voltage (V)	Test Frequency (MHz)	Deviation (Hz)	Limit (Hz)
4.2	836.50	-27	± 2078.8
3.7	836.50	33	± 2078.8
3.4	836.50	-17	± 2078.8

Product	Wireless Module		
Test Item	Frequency Stability Under Temperature & Voltage Variations		
Test Mode	Mode 1: LTE Band 26 (5M/QPSK)		
Date of Test	2015/07/09	Test Site	TR7

Frequency Stability under Temperature

Temperature Interval (°C)	Test Frequency (MHz)	Deviation (Hz)	Limit (Hz)
-30	836.50	36	± 2078.8
-20	836.50	54	± 2078.8
-10	836.50	50	± 2078.8
0	836.50	47	± 2078.8
10	836.50	-58	± 2078.8
20	836.50	17	± 2078.8
30	836.50	51	± 2078.8
40	836.50	38	± 2078.8
50	836.50	-26	± 2078.8

Frequency Stability under Voltage

DC Voltage (V)	Test Frequency (MHz)	Deviation (Hz)	Limit (Hz)
4.2	836.50	44	± 2078.8
3.7	836.50	-32	± 2078.8
3.4	836.50	11	± 2078.8

Product	Wireless Module		
Test Item	Frequency Stability Under Temperature & Voltage Variations		
Test Mode	Mode 1: LTE Band 26 (5M/16QAM)		
Date of Test	2015/07/09	Test Site	TR7

Frequency Stability under Temperature

Temperature Interval (°C)	Test Frequency (MHz)	Deviation (Hz)	Limit (Hz)
-30	836.50	-34	± 2078.8
-20	836.50	-56	± 2078.8
-10	836.50	47	± 2078.8
0	836.50	-54	± 2078.8
10	836.50	-49	± 2078.8
20	836.50	39	± 2078.8
30	836.50	59	± 2078.8
40	836.50	55	± 2078.8
50	836.50	-56	± 2078.8

Frequency Stability under Voltage

DC Voltage (V)	Test Frequency (MHz)	Deviation (Hz)	Limit (Hz)
4.2	836.50	-46	± 2078.8
3.7	836.50	35	± 2078.8
3.4	836.50	-42	± 2078.8

Product	Wireless Module		
Test Item	Frequency Stability Under Temperature & Voltage Variations		
Test Mode	Mode 1: LTE Band 26 (3M/QPSK)		
Date of Test	2015/07/09	Test Site	TR7

Frequency Stability under Temperature

Temperature Interval (°C)	Test Frequency (MHz)	Deviation (Hz)	Limit (Hz)
-30	836.50	-52	± 2078.8
-20	836.50	-39	± 2078.8
-10	836.50	47	± 2078.8
0	836.50	52	± 2078.8
10	836.50	37	± 2078.8
20	836.50	-50	± 2078.8
30	836.50	-47	± 2078.8
40	836.50	47	± 2078.8
50	836.50	42	± 2078.8

Frequency Stability under Voltage

DC Voltage (V)	Test Frequency (MHz)	Deviation (Hz)	Limit (Hz)
4.2	836.50	44	± 2078.8
3.7	836.50	-35	± 2078.8
3.4	836.50	-28	± 2078.8

Product	Wireless Module		
Test Item	Frequency Stability Under Temperature & Voltage Variations		
Test Mode	Mode 1: LTE Band 26 (3M/16QAM)		
Date of Test	2015/07/09	Test Site	TR7

Frequency Stability under Temperature

Temperature Interval (°C)	Test Frequency (MHz)	Deviation (Hz)	Limit (Hz)
-30	836.50	50	± 2078.8
-20	836.50	57	± 2078.8
-10	836.50	34	± 2078.8
0	836.50	47	± 2078.8
10	836.50	-49	± 2078.8
20	836.50	-58	± 2078.8
30	836.50	-43	± 2078.8
40	836.50	47	± 2078.8
50	836.50	44	± 2078.8

Frequency Stability under Voltage

DC Voltage (V)	Test Frequency (MHz)	Deviation (Hz)	Limit (Hz)
4.2	836.50	-37	± 2078.8
3.7	836.50	45	± 2078.8
3.4	836.50	39	± 2078.8

Product	Wireless Module		
Test Item	Frequency Stability Under Temperature & Voltage Variations		
Test Mode	Mode 1: LTE Band 26 (1.4M/QPSK)		
Date of Test	2015/07/09	Test Site	TR7

Frequency Stability under Temperature

Temperature Interval (°C)	Test Frequency (MHz)	Deviation (Hz)	Limit (Hz)
-30	836.50	43	± 2078.8
-20	836.50	-43	± 2078.8
-10	836.50	27	± 2078.8
0	836.50	57	± 2078.8
10	836.50	56	± 2078.8
20	836.50	-56	± 2078.8
30	836.50	-47	± 2078.8
40	836.50	46	± 2078.8
50	836.50	36	± 2078.8

Frequency Stability under Voltage

DC Voltage (V)	Test Frequency (MHz)	Deviation (Hz)	Limit (Hz)
4.2	836.50	43	± 2078.8
3.7	836.50	-36	± 2078.8
3.4	836.50	-41	± 2078.8

Product	Wireless Module		
Test Item	Frequency Stability Under Temperature & Voltage Variations		
Test Mode	Mode 1: LTE Band 26 (1.4M/16QAM)		
Date of Test	2015/07/09	Test Site	TR7

Frequency Stability under Temperature

Temperature Interval (°C)	Test Frequency (MHz)	Deviation (Hz)	Limit (Hz)
-30	836.50	48	± 2078.8
-20	836.50	42	± 2078.8
-10	836.50	-40	± 2078.8
0	836.50	-25	± 2078.8
10	836.50	-56	± 2078.8
20	836.50	-49	± 2078.8
30	836.50	-39	± 2078.8
40	836.50	-41	± 2078.8
50	836.50	-48	± 2078.8

Frequency Stability under Voltage

DC Voltage (V)	Test Frequency (MHz)	Deviation (Hz)	Limit (Hz)
4.2	836.50	-33	± 2078.8
3.7	836.50	-45	± 2078.8
3.4	836.50	28	± 2078.8

LTE Band 26 For Part 90S

Product	Wireless Module		
Test Item	Frequency Stability Under Temperature & Voltage Variations		
Test Mode	Mode 1: LTE Band 26 (10M/QPSK)		
Date of Test	2015/07/09	Test Site	TR7

Frequency Stability under Temperature

Temperature Interval (°C)	Test Frequency (MHz)	Deviation (Hz)	Limit (Hz)
-30	819.00	46	± 2078.8
-20	819.00	-52	± 2078.8
-10	819.00	59	± 2078.8
0	819.00	39	± 2078.8
10	819.00	-58	± 2078.8
20	819.00	36	± 2078.8
30	819.00	51	± 2078.8
40	819.00	-26	± 2078.8
50	819.00	-50	± 2078.8

Frequency Stability under Voltage

DC Voltage (V)	Test Frequency (MHz)	Deviation (Hz)	Limit (Hz)
4.2	819.00	-44	± 2078.8
3.7	819.00	22	± 2078.8
3.4	819.00	-11	± 2078.8

Product	Wireless Module		
Test Item	Frequency Stability Under Temperature & Voltage Variations		
Test Mode	Mode 1: LTE Band 26 (10M/16QAM)		
Date of Test	2015/07/09	Test Site	TR7

Frequency Stability under Temperature

Temperature Interval (°C)	Test Frequency (MHz)	Deviation (Hz)	Limit (Hz)
-30	819.00	-48	± 2078.8
-20	819.00	31	± 2078.8
-10	819.00	53	± 2078.8
0	819.00	-45	± 2078.8
10	819.00	-51	± 2078.8
20	819.00	56	± 2078.8
30	819.00	-30	± 2078.8
40	819.00	47	± 2078.8
50	819.00	37	± 2078.8

Frequency Stability under Voltage

DC Voltage (V)	Test Frequency (MHz)	Deviation (Hz)	Limit (Hz)
4.2	819.00	-44	± 2078.8
3.7	819.00	32	± 2078.8
3.4	819.00	19	± 2078.8

Product	Wireless Module		
Test Item	Frequency Stability Under Temperature & Voltage Variations		
Test Mode	Mode 1: LTE Band 26 (5M/QPSK)		
Date of Test	2015/07/09	Test Site	TR7

Frequency Stability under Temperature

Temperature Interval (°C)	Test Frequency (MHz)	Deviation (Hz)	Limit (Hz)
-30	819.00	-35	± 2078.8
-20	819.00	53	± 2078.8
-10	819.00	-49	± 2078.8
0	819.00	47	± 2078.8
10	819.00	-57	± 2078.8
20	819.00	19	± 2078.8
30	819.00	35	± 2078.8
40	819.00	37	± 2078.8
50	819.00	-25	± 2078.8

Frequency Stability under Voltage

DC Voltage (V)	Test Frequency (MHz)	Deviation (Hz)	Limit (Hz)
4.2	819.00	-38	± 2078.8
3.7	819.00	19	± 2078.8
3.4	819.00	23	± 2078.8

Product	Wireless Module		
Test Item	Frequency Stability Under Temperature & Voltage Variations		
Test Mode	Mode 1: LTE Band 26 (5M/16QAM)		
Date of Test	2015/07/09	Test Site	TR7

Frequency Stability under Temperature

Temperature Interval (°C)	Test Frequency (MHz)	Deviation (Hz)	Limit (Hz)
-30	819.00	43	± 2078.8
-20	819.00	-55	± 2078.8
-10	819.00	46	± 2078.8
0	819.00	-53	± 2078.8
10	819.00	-48	± 2078.8
20	819.00	48	± 2078.8
30	819.00	-58	± 2078.8
40	819.00	34	± 2078.8
50	819.00	35	± 2078.8

Frequency Stability under Voltage

DC Voltage (V)	Test Frequency (MHz)	Deviation (Hz)	Limit (Hz)
4.2	819.00	-35	± 2078.8
3.7	819.00	44	± 2078.8
3.4	819.00	29	± 2078.8

Product	Wireless Module		
Test Item	Frequency Stability Under Temperature & Voltage Variations		
Test Mode	Mode 1: LTE Band 26 (3M/QPSK)		
Date of Test	2015/07/09	Test Site	TR7

Frequency Stability under Temperature

Temperature Interval (°C)	Test Frequency (MHz)	Deviation (Hz)	Limit (Hz)
-30	819.00	44	± 2078.8
-20	819.00	-38	± 2078.8
-10	819.00	-46	± 2078.8
0	819.00	38	± 2078.8
10	819.00	36	± 2078.8
20	819.00	49	± 2078.8
30	819.00	-46	± 2078.8
40	819.00	61	± 2078.8
50	819.00	-41	± 2078.8

Frequency Stability under Voltage

DC Voltage (V)	Test Frequency (MHz)	Deviation (Hz)	Limit (Hz)
4.2	819.00	32	± 2078.8
3.7	819.00	18	± 2078.8
3.4	819.00	34	± 2078.8

Product	Wireless Module		
Test Item	Frequency Stability Under Temperature & Voltage Variations		
Test Mode	Mode 1: LTE Band 26 (3M/16QAM)		
Date of Test	2015/07/09	Test Site	TR7

Frequency Stability under Temperature

Temperature Interval (°C)	Test Frequency (MHz)	Deviation (Hz)	Limit (Hz)
-30	819.00	-49	± 2078.8
-20	819.00	56	± 2078.8
-10	819.00	23	± 2078.8
0	819.00	-46	± 2078.8
10	819.00	-48	± 2078.8
20	819.00	-57	± 2078.8
30	819.00	42	± 2078.8
40	819.00	46	± 2078.8
50	819.00	-43	± 2078.8

Frequency Stability under Voltage

DC Voltage (V)	Test Frequency (MHz)	Deviation (Hz)	Limit (Hz)
4.2	819.00	43	± 2078.8
3.7	819.00	29	± 2078.8
3.4	819.00	-35	± 2078.8

Product	Wireless Module		
Test Item	Frequency Stability Under Temperature & Voltage Variations		
Test Mode	Mode 1: LTE Band 26 (1.4M/QPSK)		
Date of Test	2015/07/09	Test Site	TR7

Frequency Stability under Temperature

Temperature Interval (°C)	Test Frequency (MHz)	Deviation (Hz)	Limit (Hz)
-30	819.00	32	± 2078.8
-20	819.00	-42	± 2078.8
-10	819.00	26	± 2078.8
0	819.00	-56	± 2078.8
10	819.00	45	± 2078.8
20	819.00	38	± 2078.8
30	819.00	46	± 2078.8
40	819.00	45	± 2078.8
50	819.00	35	± 2078.8

Frequency Stability under Voltage

DC Voltage (V)	Test Frequency (MHz)	Deviation (Hz)	Limit (Hz)
4.2	819.00	-43	± 2078.8
3.7	819.00	66	± 2078.8
3.4	819.00	51	± 2078.8

Product	Wireless Module		
Test Item	Frequency Stability Under Temperature & Voltage Variations		
Test Mode	Mode 1: LTE Band 26 (1.4M/16QAM)		
Date of Test	2015/07/09	Test Site	TR7

Frequency Stability under Temperature

Temperature Interval (°C)	Test Frequency (MHz)	Deviation (Hz)	Limit (Hz)
-30	819.00	-47	± 2078.8
-20	819.00	-41	± 2078.8
-10	819.00	39	± 2078.8
0	819.00	45	± 2078.8
10	819.00	55	± 2078.8
20	819.00	-48	± 2078.8
30	819.00	-38	± 2078.8
40	819.00	50	± 2078.8
50	819.00	-37	± 2078.8

Frequency Stability under Voltage

DC Voltage (V)	Test Frequency (MHz)	Deviation (Hz)	Limit (Hz)
4.2	819.00	-29	± 2078.8
3.7	819.00	-35	± 2078.8
3.4	819.00	43	± 2078.8

_____ The End _____