

# FCC/ISED Test Report

Product Name : Module  
Trade Name : AirPrime  
Model No. : EM7411  
FCC ID : N7NEM74B  
IC : 2417C-EM74B

Applicant : SIERRA WIRELESS, INC.  
Address : 13811 Wireless Way, Richmond, BC, Canada V6V 3A4  
Canada

Date of Receipt : Jun. 30, 2020  
Issued Date : Nov. 19, 2020  
Report No. : 2061278R-E3042110012  
Report Version : V1.0



The test results relate only to the samples tested.  
The test report shall not be reproduced except in full without the written approval of DEKRA Testing and Certification Co., Ltd..

# Test Report Certification

Issued Date : Nov. 19, 2020

Report No. : 2061278R-E3042110012



Product Name : Module  
 Applicant : SIERRA WIRELESS, INC.  
 Address : 13811 Wireless Way, Richmond, BC, Canada V6V 3A4  
 Canada  
 Manufacturer : SIERRA WIRELESS, INC.  
 Trade Name : AirPrime  
 Model No. : EM7411  
 FCC ID : N7NEM74B  
 IC : 2417C-EM74B  
 EUT Voltage : DC 3.7V  
 Testing Voltage : DC 3.7V  
 Applicable Standard : FCC CFR Title 47 Part 22 Subpart H  
 FCC CFR Title 47 Part 24 Subpart E  
 FCC CFR Title 47 Part 27 Subpart L, Subpart M, Subpart F  
 FCC CFR Title 47 Part 90 Subpart S, Subpart R  
 ANSI/TIA-603  
 RSS-GEN Issue 5, RSS-130 Issue 2, RSS-132 Issue 3,  
 RSS-133 Issue 6, RSS-139 Issue 3, RSS-140 Issue 1,  
 RSS-199 Issue 3

Test Lab : Hsin Chu Laboratory  
 Address : No.372-2, Sec. 4, Zhongxing Rd., Zhudong Township, Hsinchu  
 County 310, Taiwan, R.O.C.  
 TEL: +886-3-582-8001 / FAX: +886-3-582-8958

Test Result : Complied

Documented By :   
 \_\_\_\_\_  
 ( Demi Chang / Senior Engineering Adm. Specialist )

Tested By :   
 \_\_\_\_\_  
 ( Max Chang / Engineer )

Approved By :   
 \_\_\_\_\_  
 ( Louis Hsu / Deputy Manager )

**Revision History**

<b>Version</b>	<b>Description</b>	<b>Issued Date</b>
V1.0	Initial issue of report	Nov. 19, 2020

## TABLE OF CONTENTS

Description	Page
1. General Information .....	6
1.1. EUT Description .....	6
1.2. Mode of Operation .....	7
1.3. Tested System Details .....	8
1.4. Configuration of Tested System .....	8
1.5. Operation Descriptions .....	8
1.6. Comments and Remarks .....	9
2. Technical Test .....	10
2.1. Summary of Test Result .....	10
2.2. Test Environment .....	25
2.3. List of Test Equipment .....	27
2.4. Measurement Uncertainty .....	30
3. RF Output Power .....	31
3.1. Test Setup .....	31
3.2. Test Procedure .....	31
3.3. Test Method .....	31
3.4. Test Result .....	32
4. Occupied Bandwidth .....	120
4.1. Test Setup .....	120
4.2. Test Procedure .....	120
4.3. Test Method .....	120
4.4. Test Result .....	121
5. Peak To Average Ratio .....	435
5.1. Test Setup .....	435
5.2. Test Procedure .....	435
5.3. Test Method .....	435
5.4. Test Result .....	436
6. Spurious Emissions .....	636
6.1. Test Setup .....	636
6.2. Test Procedure .....	637
6.3. Test Method .....	637
6.4. Test Result .....	638
7. Spurious Emissions at Antenna Terminals .....	840
7.1. Test Setup .....	840
7.2. Test Procedure .....	840

---

7.3. Test Method .....	840
7.4. Test Result .....	841
8. Frequency Stability .....	973
8.1. Test Setup .....	973
8.2. Test Procedure .....	974
8.3. Test Method .....	974
8.4. Test Result .....	975
Attachment 1 .....	1002
Test Setup Photograph .....	1002
Attachment 2 .....	1005
EUT Photograph .....	1005
Attachment 3 .....	1009
EUT Internal Photograph .....	1009

## 1. General Information

### 1.1. EUT Description

Product Name	Module	
Trade Name	AirPrime	
Model No.	EM7411	
Uplink Frequency Range (MHz)	Band 2: 1850~1910 Band 4: 1710~1755 Band 5: 824~849 Band 7: 2500~2570 Band 12: 699~716 Band 13: 777~787	Band 14: 788~798 Band 25: 1850~1915 Band 26: 814~849 Band 41: 2496~2690 Band 66: 1710~1780 Band 71: 663~698
Downlink Frequency Range (MHz)	Band 2: 1930~1990 Band 4: 2110~2115 Band 5: 869~894 Band 7: 2620~2690 Band 12: 729~746 Band 13: 746~756	Band 14: 758~768 Band 25: 1930~1995 Band 26: 859~894 Band 41: 2496~2690 Band 66: 2110~2200 Band 71: 617~652
Modulation	QPSK / 16QAM / 64QAM	
HW Version	1.0	
SW Version	SWI9X50C_01.13.02.00 22fdf9	
IMEI No.	356280110001130	

Antenna Information	
Trade Name	PANORAMA ANTENNAS
Model No.	PWB-7-60
Antenna Type	Dipole Antenna
Antenna Gain	698-960MHz / 2.4-2.7GHz: 4dBi 1710-2170MHz: 2dBi

#### Note:

1. This EM7411 supports WCDMA Band 2/4/5, LTE Band 2/4/5/7/12/13/14/25/26/41/66/71 and CA Band 5B, 7C, 41C.
2. Regarding frequency band operation, the lowest, middle and highest frequency of channel were selected to perform the test, and the details were shown on this report.
3. The EUT description is from the customer declaration.
4. This device was tested under all bandwidths, RB configurations and modulations. The worst case was found in QPSK modulation and show the worst case in "Spurious Emissions at Antenna Terminals" & "Spurious emission".

## 1.2. Mode of Operation

DEKRA has verified the construction and function in typical operation. All the test modes were carried out with the EUT in normal operation, which was shown in this test report and defined as:

Test Mode
Mode 1: LTE Band 2/25
Mode 2: LTE Band 4/66
Mode 3: LTE Band 5/26 (Part 22)
Mode 4: LTE Band 7
Mode 5: LTE Band 12
Mode 6: LTE Band 13
Mode 7: LTE Band 14
Mode 8: LTE Band 26 (Part 90)
Mode 9: LTE Band 41
Mode 10: LTE Band 71
Mode 11: LTE CA Band 5B
Mode 12: LTE CA Band 7C
Mode 13: LTE CA Band 41C

### 1.3. Tested System Details

The types for all equipment, plus descriptions of all cables used in the tested system (including inserted cards) are:

Product	Manufacturer	Model No.	Serial No.	FCC ID	Power Cord
1   Base Station	R&S	CMW500	157118	DoC	Non-Shielded, 2m
2   Horn Antenna	Schwarzbeck	BBHA 9120D	1640	DoC	--

### 1.4. Configuration of Tested System

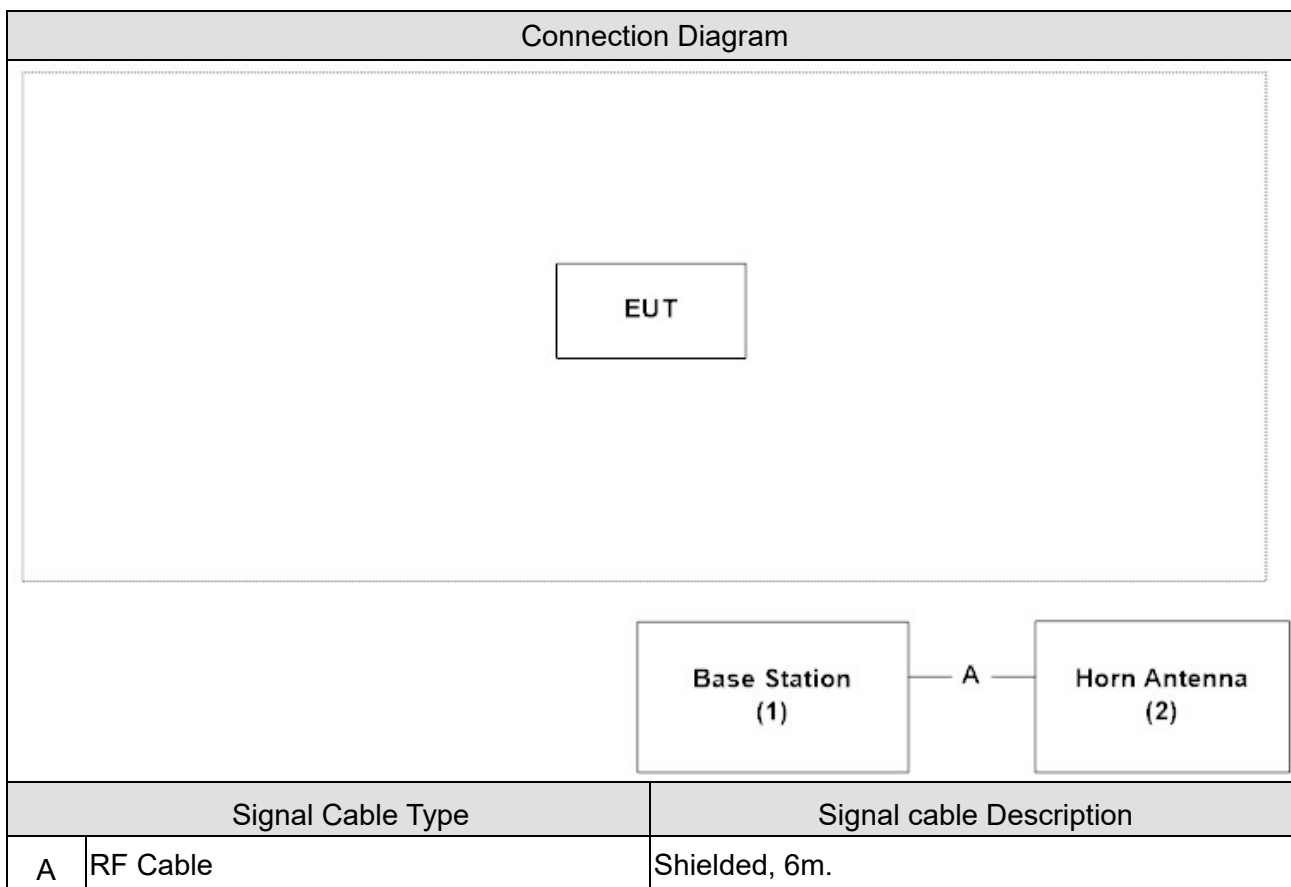

### 1.5. Operation Descriptions

1	Setup the EUT and simulators as shown on.
2	Turn on the power of all equipment.
3	The EUT will continue receive the signal from LTE function.
4	Repeat the above procedure.



## **1.6. Comments and Remarks**

The product specification and testing instructions for the EUT declared in the report are provided by the manufacturer who will take all responsibilities for the accuracy.

## 2. Technical Test

### 2.1. Summary of Test Result

- No deviations from the test standards
- Deviations from the test standards as below description:

B2

Uplink: 1850-1910MHz

Downlink: 1930-1990MHz

LTE B2					
FCC Part 24 Subpart E					
Industry Canada RSS-133, issue 6, Industry Canada RSS-GEN					
Test item	FCC Reference section	FCC Limit	IC Reference section	IC Limit	Result
RF Output Power	§2.1033 §2.1046 §24.232	<2 Watts	§6.4	<2 Watts	Pass
Occupied Bandwidth	§2.1049	N/A	RSS-GEN §4.2	N/A	Pass
Peak-to-average power ratio	§24.232	<13 dB	§6.4	<13 dB	Pass
Spurious Emissions	§2.1053 §24.238	<-13dBm	§6.5	<-13dBm	Pass
Spurious Emissions at Antenna Terminals	§27.238	<-13dBm	§6.5	<-13dBm	Pass
Frequency Stability	§2.1055 §24.235	<±2.5 ppm	§6.3	<±2.5 ppm	Pass

Determining compliance shall be based on the results of the compliance measurement, not taking into account measurement instrumentation uncertainty.

B4

Uplink: 1710-1755MHz

Downlink: 2100-2155MHz

LTE B4					
FCC Part 27 Subpart L					
Industry Canada RSS-139, issue 3, Industry Canada RSS-GEN					
Test item	FCC Reference section	FCC Limit	IC Reference section	IC Limit	Result
RF Output Power	§2.1033 §2.1046 §27.50	<1 Watt	§6.5	<1 Watt	Pass
Occupied Bandwidth	§2.1049	N/A	RSS-GEN §4.2	N/A	Pass
Peak-to-average power ratio	§27.50	<13 dB	§6.5	<13 dB	Pass
Spurious Emissions	§2.1053 §27.53	<-13dBm	§6.6	<-13dBm	Pass
Spurious Emissions at Antenna Terminals	§27.53	<-13dBm	§6.6	<-13dBm	Pass
Frequency Stability	§2.1055 §27.54	<2.5 ppm	§6.4	Within the frequency range	Pass

Determining compliance shall be based on the results of the compliance measurement, not taking into account measurement instrumentation uncertainty.

B5

Uplink: 824-849MHz

Downlink: 869-894MHz

LTE B5					
FCC Part 22 Subpart H					
Industry Canada RSS-132, issue 3, Industry Canada RSS-GEN					
Test item	FCC Reference section	FCC Limit	IC Reference section	IC Limit	Result
RF Output Power	§2.1033 §2.1046 §22.913	<7 Watts	§5.4	<7 Watts EIRP: <11.5 Watts	Pass
Occupied Bandwidth	§2.1049	N/A	RSS-GEN §4.2	N/A	Pass
Peak-to-average power ratio	§22.913	<13 dB	§5.4	<13 dB	Pass
Spurious Emissions	§2.1053 §22.917	<-13dBm	§5.5	<-13dBm	Pass
Spurious Emissions at Antenna Terminals	§22.917	<-13dBm	§5.5	<-13dBm	Pass
Frequency Stability	§2.1055 §22.335	<±2.5 ppm	§5.3	<±2.5 ppm for mobile stations <±1.5 ppm for base stations	Pass

Determining compliance shall be based on the results of the compliance measurement, not taking into account measurement instrumentation uncertainty.

B7

Uplink: 2500-2570MHz

Downlink: 2620-2690MHz

LTE B7					
FCC Part 27 Subpart M					
Industry Canada RSS-199, issue 3, Industry Canada RSS-GEN					
Test item	FCC Reference section	FCC Limit	IC Reference section	IC Limit	Result
RF Output Power	§2.1033 §2.1046 §27.50	<2 Watts	§4.4	<2 Watts	Pass
Occupied Bandwidth	§2.1049	N/A	RSS-GEN §4.2	N/A	Pass
Peak-to-average power ratio	§27.50	<13 dB	§4.4	<13 dB	Pass
Spurious Emissions	§2.1053 §27.53	<-25dBm	§4.5	<-25dBm	Pass
Spurious Emissions at Antenna Terminals	§27.53	<5MHz:-10dBm 5MHz-X MHz:-13dBm>X MHz:-25dBm	§4.5	<5MHz:-10dBm 5MHz-X MHz:-13dBm>X MHz:-25dBm	Pass
Frequency Stability	§2.1055 §27.54	<±2.5 ppm	§4.3	Within the frequency range	Pass

Determining compliance shall be based on the results of the compliance measurement, not taking into account measurement instrumentation uncertainty.

B12

Uplink: 699-716MHz

Downlink: 729-746MHz

LTE B12					
FCC Part 27 Subpart F					
Industry Canada RSS-130, issue 2, Industry Canada RSS-GEN					
Test item	FCC Reference section	FCC Limit	IC Reference section	IC Limit	Result
RF Output Power	§2.1033 §2.1046 §27.50	<3 Watts ERP	§4.6	<3 Watts E.R.P for portable equipment or for indoor fixed subscriber equipment	Pass
Occupied Bandwidth	§2.1049	N/A	RSS-GEN §4.2	N/A	Pass
Peak-to-average power ratio	§27.50	<13 dB	§4.4	<13 dB	Pass
Spurious Emissions	§2.1053 §27.53	<-13dBm	§4.6	<-13dBm The e.i.r.p. in the band 1559-1610 MHz shall not exceed -70 dBW/MHz for wideband signal and -80 dBW for discrete emission with bandwidth less than 700 Hz.	Pass
Spurious Emissions at Antenna Terminals	§27.53	<-13dBm	§4.6	<-13dBm	Pass
Frequency Stability	§2.1055 §27.54	<±2.5 ppm	§4.3	Within the frequency range	Pass

Determining compliance shall be based on the results of the compliance measurement, not taking into account measurement instrumentation uncertainty.

B13

Uplink: 777-787MHz

Downlink: 746-756MHz

LTE B13					
FCC Part 27 Subpart F					
Industry Canada RSS-130, issue 2, Industry Canada RSS-GEN					
RF Output Power	FCC Reference section	FCC Limit	IC Reference section	IC Limit	Result
RF Output Power	§2.1033 §2.1046 §27.50	<3 Watts ERP	§4.6	<3 Watts E.R.P for portable equipment or for indoor fixed subscriber equipment	Pass
Occupied Bandwidth	§2.1049	N/A	RSS-GEN §4.2	N/A	Pass
Peak-to-average power ratio	§27.50	<-13 dB	§4.4	<13 dB	Pass
Spurious Emissions	§2.1053 §27.53	<-13dBm	§4.6	<-13dBm	Pass
Spurious Emissions at Antenna Terminals	§27.53	<-13dBm	§4.6	<-13dBm	Pass
Frequency Stability	§2.1055 §27.54	<±2.5 ppm	§4.5	Within the frequency range	Pass

Determining compliance shall be based on the results of the compliance measurement, not taking into account measurement instrumentation uncertainty.

B14

Uplink: 788-798MHz

Downlink: 758-768MHz

LTE B14					
FCC Part 90 Subpart R					
Industry Canada RSS-140, issue 1, Industry Canada RSS-GEN					
Test item	FCC Reference section	FCC Limit	IC Reference section	IC Limit	Result
RF Output Power	§2.1033 §2.1046 §90.542	<3 Watts ERP	§4.3	<3 Watts ERP	Pass
Occupied Bandwidth	§2.1049	N/A	RSS-GEN §4.2	N/A	Pass
Peak-to-average power ratio	§27.50	<13 dB	§4.3	<13 dB	Pass
Spurious Emissions	§2.1053 §90.543	<-13dBm	§4.4	<-13dBm <-70 dBW/MHz e.i.r.p.of all emissions, including harmonics in the band 1559-1610 MHz,	Pass
Spurious Emissions at Antenna Terminals	§90.543	<-35dBm	§4.4	<-35dBm. for mobile and portable/hand-held equipment	Pass
Frequency Stability	§2.1055 §90.543	<±2.5 ppm	§4.2	Within the frequency range	Pass

Determining compliance shall be based on the results of the compliance measurement, not taking into account measurement instrumentation uncertainty.



B25

Uplink: 1850~1915MHz

Downlink: 1930~1995MHz

LTE B25					
FCC Part 24 Subpart E					
Industry Canada RSS-133, issue 6, Industry Canada RSS-GEN					
Test item	FCC Reference section	FCC Limit	IC Reference section	IC Limit	Result
RF Output Power	§2.1033 §2.1046 §24.232	<2 Watts	§6.4	<2 Watts	Pass
Occupied Bandwidth	§2.1049	N/A	RSS-GEN §4.2	N/A	Pass
Peak-to-average power ratio	§24.232	<13 dB	§6.4	<13 dB	Pass
Spurious Emissions	§2.1053 §24.238	<-13dBm	§6.5	<-13dBm	Pass
Spurious Emissions at Antenna Terminals	§27.238	<-13dBm	§6.5	<-13dBm	Pass
Frequency Stability	§2.1055 §24.235	<±2.5 ppm	§6.3	<±2.5 ppm	Pass

Determining compliance shall be based on the results of the compliance measurement, not taking into account measurement instrumentation uncertainty.

B26

Uplink: 814~849MHz (ISED not support 814~824 MHz)

Downlink: 859~894MHz

LTE B26					
FCC Part 22 Subpart H					
FCC Part 90 Subpart S					
Industry Canada RSS-132, issue 3, Industry Canada RSS-GEN					
Test item	FCC Reference section	FCC Limit	IC Reference section	IC Limit	Result
RF Output Power	§2.1033 §2.1046 §90.635(b) §22.913	<100 Watts	§5.4	<11.5 Watts	Pass
Occupied Bandwidth	§2.1049	N/A	RSS-GEN §4.2	N/A	Pass
Peak-to-average power ratio	§22.913	<13 dB	§5.4	<13 dB	Pass
Spurious Emissions	§2.1053 §90.691 §22.917	<-13dBm	§5.5	<-13dBm	Pass
Spurious Emissions at Antenna Terminals	§90.691 §22.917	<-13dBm	§5.5	<-13dBm	Pass
Frequency Stability	§2.1055 §90.213	<±2.5 ppm	§5.2	<±2.5ppm	Pass

Determining compliance shall be based on the results of the compliance measurement, not taking into account measurement instrumentation uncertainty.

B41

Uplink: 2496~2690MHz for FCC, 2500~2690MHz for ISSED

Downlink: 2496~2690MHz

LTE B41					
FCC Part 27 Subpart M					
Industry Canada RSS-199, issue 3, Industry Canada RSS-GEN					
Test item	FCC Reference section	FCC Limit	IC Reference section	IC Limit	Result
RF Output Power	§2.1033 §2.1046 §27.50	<2 Watts	§4.4	<2 Watts	Pass
Occupied Bandwidth	§2.1049	N/A	RSS-GEN §4.2	N/A	Pass
Peak-to-average power ratio	§27.50	<13 dB	§4.4	<13 dB	Pass
Spurious Emissions	§2.1053 §27.53	<-25dBm	§4.5	<-25dBm	Pass
Spurious Emissions at Antenna Terminals	§27.53	-25dBm	§4.5	<5MHz:-10dBm 5NHZ-X MHz:-13dBm>X MHz:-25dBm	Pass
Frequency Stability	§2.1055 §27.54	<±2.5 ppm	§4.3	Within the frequency range	Pass

Determining compliance shall be based on the results of the compliance measurement, not taking into account measurement instrumentation uncertainty.

B66

Uplink: 1710~1780MHz

Downlink: 2110~2200MHz

LTE B66					
FCC Part 27 Subpart L					
Industry Canada RSS-139, issue 3, Industry Canada RSS-GEN					
Test item	FCC Reference section	FCC Limit	IC Reference section	IC Limit	Result
RF Output Power	§2.1033 §2.1046 §27.50	<1 Watts	§6.5	<1 Watts	Pass
Occupied Bandwidth	§2.1049	N/A	RSS-GEN §4.2	N/A	Pass
Peak-to-average power ratio	§27.50	<13 dB	§6.5	<13 dB	Pass
Spurious Emissions	§2.1053 §27.53	<-13dBm	§6.6	<-13dBm	Pass
Spurious Emissions at Antenna Terminals	§27.53	<-13dBm	§6.6	<-13dBm	Pass
Frequency Stability	§2.1055 §27.54	<2.5 ppm	§6.4	Within the frequency range	Pass

Determining compliance shall be based on the results of the compliance measurement, not taking into account measurement instrumentation uncertainty.

B71

Uplink: 663~698MHz

Downlink: 617~652MHz

LTE B71					
FCC Part 27 Subpart F					
Industry Canada RSS-130, issue 2, Industry Canada RSS-GEN					
Test item	FCC Reference section	FCC Limit	IC Reference section	IC Limit	Result
RF Output Power	§2.1033 §2.1046 §27.50	<3 Watts	§4.6	<3 Watts E.R.P for portable equipment or for indoor fixed subscriber equipment	Pass
Occupied Bandwidth	§2.1049	N/A	RSS-GEN §4.2	N/A	Pass
Peak-to-average power ratio	§27.50	<13 dB	§4.6	<13 dB	Pass
Spurious Emissions	§2.1053 §27.53	<-13dBm	§4.7	<-13dBm	Pass
Spurious Emissions at Antenna Terminals	§27.53	<-13dBm	§4.7	<-13dBm	Pass
Frequency Stability	§2.1055 §27.54	<2.5 ppm	§4.5	Within the frequency range	Pass

Determining compliance shall be based on the results of the compliance measurement, not taking into account measurement instrumentation uncertainty.

5B

Uplink: 824-849MHz

Downlink: 869-894MHz

LTE B5					
FCC Part 22 Subpart H					
Industry Canada RSS-132, issue 3, Industry Canada RSS-GEN					
Test item	FCC Reference section	FCC Limit	IC Reference section	IC Limit	Result
RF Output Power	§2.1033 §2.1046 §22.913	<7 Watts	§5.4	<7 Watts EIRP: <11.5 Watts	Pass
Occupied Bandwidth	§2.1049	N/A	RSS-GEN §4.2	N/A	Pass
Peak-to-average power ratio	§22.913	<13 dB	§5.4	<13 dB	Pass
Spurious Emissions	§2.1053 §22.917	<-13dBm	§5.5	<-13dBm	Pass
Spurious Emissions at Antenna Terminals	§22.917	<-13dBm	§5.5	<-13dBm	Pass
Frequency Stability	§2.1055 §22.335	<±2.5 ppm	§5.3	<±2.5 ppm for mobile stations <±1.5 ppm for base stations	Pass

Determining compliance shall be based on the results of the compliance measurement, not taking into account measurement instrumentation uncertainty.

7C

Uplink: 2500-2570MHz

Downlink: 2620-2690MHz

LTE B7					
FCC Part 27 Subpart M					
Industry Canada RSS-199, issue 3, Industry Canada RSS-GEN					
Test item	FCC Reference section	FCC Limit	IC Reference section	IC Limit	Result
RF Output Power	§2.1033 §2.1046 §27.50	<2 Watts	§4.4	<2 Watts	Pass
Occupied Bandwidth	§2.1049	N/A	RSS-GEN §4.2	N/A	Pass
Peak-to-average power ratio	§27.50	<13 dB	§4.4	<13 dB	Pass
Spurious Emissions	§2.1053 §27.53	<-25dBm	§4.5	<-25dBm	Pass
Spurious Emissions at Antenna Terminals	§27.53	<5MHz:-10dBm 5MHz-X MHz:-13dBm>X MHz:-25dBm	§4.5	<5MHz:-10dBm 5MHz-X MHz:-13dBm>X MHz:-25dBm	Pass
Frequency Stability	§2.1055 §27.54	<±2.5 ppm	§4.3	Within the frequency range	Pass

Determining compliance shall be based on the results of the compliance measurement, not taking into account measurement instrumentation uncertainty.

41C

Uplink: 2496~2690MHz for FCC, 2500~2690MHz for ISED

Downlink: 2496~2690MHz

LTE B41					
FCC Part 27 Subpart M					
Industry Canada RSS-199, issue 3, Industry Canada RSS-GEN					
Test item	FCC Reference section	FCC Limit	IC Reference section	IC Limit	Result
RF Output Power	§2.1033 §2.1046 §27.50	<2 Watts	§4.4	<2 Watts	Pass
Occupied Bandwidth	§2.1049	N/A	RSS-GEN §4.2	N/A	Pass
Peak-to-average power ratio	§27.50	<13 dB	§4.4	<13 dB	Pass
Spurious Emissions	§2.1053 §27.53	<-25dBm	§4.5	<-25dBm	Pass
Spurious Emissions at Antenna Terminals	§27.53	-25dBm	§4.5	<5MHz:-10dBm 5NHZ-X MHz:-13dBm>X MHz:-25dBm	Pass
Frequency Stability	§2.1055 §27.54	<±2.5 ppm	§4.3	Within the frequency range	Pass

Determining compliance shall be based on the results of the compliance measurement, not taking into account measurement instrumentation uncertainty.



## 2.2. Test Environment

Items	Test Item	Required	Test Site
Temperature (°C)	RF Output Power	15 - 35	2
Humidity (%RH)		20 - 75	
Temperature (°C)	Occupied Bandwidth	15 - 35	2
Humidity (%RH)		20 - 75	
Temperature (°C)	Peak To Average Ratio	15 - 35	2
Humidity (%RH)		20 - 75	
Temperature (°C)	Spurious Emission	15 - 35	2
Humidity (%RH)		20 - 75	
Temperature (°C)	Spurious Emissions at Antenna Terminals	15 - 35	2
Humidity (%RH)		20 - 75	
Temperature (°C)	Frequency Stability	15 - 35	2
Humidity (%RH)		20 - 75	

Note: Test site information refers to Laboratory Information.

## Laboratory Information

**USA** : **FCC Registration Number: TW3024**  
**Canada** : **IC Registration Number: 22397-1 / 22397-2 / 22397-3**

The address and introduction of DEKRA Testing and Certification Co., Ltd. laboratories can be founded in our Web site: <http://www.dekra.com.tw>

If you have any comments, please don't hesitate to contact us. Our test sites as below:

Test Laboratory	DEKRA Testing and Certification Co., Ltd.
Address	<ol style="list-style-type: none"> <li>1. No. 75-2, 3rd Lin, WangYe Keng, Yonghxing Tsuen, Qionglin Shiang, Hsinchu County 307, Taiwan, R.O.C.</li> <li>2. No.372, Sec. 4, Zhongxing Rd., Zhudong Township, Hsinchu County 31061, Taiwan, R.O.C.</li> <li>3. No.372-2, Sec. 4, Zhongxing Rd., Zhudong Township, Hsinchu County 31061, Taiwan, R.O.C.</li> </ol>
Phone number	<ol style="list-style-type: none"> <li>1. +886-3-592-8858</li> <li>2. +886-3-582-8001</li> <li>3. +886-3-582-8001</li> </ol>
Fax number	<ol style="list-style-type: none"> <li>1. +886-3-592-8859</li> <li>2. +886-3-582-8958</li> <li>3. +886-3-582-8958</li> </ol>
E mail address	<a href="mailto:info.tw@dekra.com">info.tw@dekra.com</a>
Website	<a href="http://www.dekra.com.tw">http://www.dekra.com.tw</a>

### 2.3. List of Test Equipment

#### RF Output Power / SR12-H

Instrument	Manufacturer	Model No.	Serial No.	Cal. Date	Next Cal. Date
Signal & Spectrum Analyzer	R&S	FSV40	101049	2020/03/30	2021/03/29
EXA Signal Analyzer	Keysight	N9010A	MY51440132	2020/02/21	2021/02/20
Spectrum Analyzer	Keysight	N9030B	MY57140404	2020/06/03	2021/06/02
Spectrum Analyzer	Keysight	N9010B	MY57110159	2020/04/15	2021/04/14
Wireless Conn. Tseter	R&S	CMW500	157118	2020/07/23	2021/07/22
Wideband Radio Communication Tester	R&S	CMW500	106071	2020/02/03	2021/02/02

#### Occupied Bandwidth / SR12-H

Instrument	Manufacturer	Model No.	Serial No.	Cal. Date	Next Cal. Date
Signal & Spectrum Analyzer	R&S	FSV40	101049	2020/03/30	2021/03/29
EXA Signal Analyzer	Keysight	N9010A	MY51440132	2020/02/21	2021/02/20
Spectrum Analyzer	Keysight	N9030B	MY57140404	2020/06/03	2021/06/02
Spectrum Analyzer	Keysight	N9010B	MY57110159	2020/04/15	2021/04/14
Wireless Conn. Tseter	R&S	CMW500	157118	2020/07/23	2021/07/22
Wideband Radio Communication Tester	R&S	CMW500	106071	2020/02/03	2021/02/02

#### Peak To Average Ratio / SR12-H

Instrument	Manufacturer	Model No.	Serial No.	Cal. Date	Next Cal. Date
Signal & Spectrum Analyzer	R&S	FSV40	101049	2020/03/30	2021/03/29
EXA Signal Analyzer	Keysight	N9010A	MY51440132	2020/02/21	2021/02/20
Spectrum Analyzer	Keysight	N9030B	MY57140404	2020/06/03	2021/06/02
Spectrum Analyzer	Keysight	N9010B	MY57110159	2020/04/15	2021/04/14
Wireless Conn. Tseter	R&S	CMW500	157118	2020/07/23	2021/07/22
Wideband Radio Communication Tester	R&S	CMW500	106071	2020/02/03	2021/02/02

## Spurious Emission / CB2-H

Instrument	Manufacturer	Model No.	Serial No.	Cal. Date	Next Cal. Date
Horn Antenna	Schwarzbeck	BBHA 9120D	639	2020/06/04	2021/06/03
Bilog Antenna	Teseq	CBL6112D	23191	2020/06/12	2021/06/11
Signal & Spectrum Analyzer	R&S	FSV40	101049	2020/03/30	2021/03/29
EXA Signal Analyzer	Keysight	N9010A	MY51440132	2020/02/21	2021/02/20
Signal Analyzer	R&S	FSVA40	101455	2019/10/21	2020/10/20
Horn Antenna	Schwarzbeck	BBHA 9170	202	2019/12/27	2020/12/26
Pre-Amplifier	DEKRA	AP-400C	201801231	2019/12/03	2020/12/02
Pre-Amplifier	EMCI	EMC11830I	980366	2019/12/03	2020/12/02
Horn Antenna	Schwarzbeck	BBHA 9120D	01656	2019/10/25	2020/10/24
Pre-Amplifier	DEKRA	AP-025C	12183122	2020/09/03	2021/09/02
Signal Analyzer	R&S	FSV40	101435	2020/06/24	2021/06/23
Wideband Radio Communication Tester	R&S	CMW500	106071	2020/02/03	2021/02/02
Wireless Conn. Tseter	R&S	CMW500	157118	2020/07/23	2021/07/22
Coaxial Cable(13m)	Huber+Suhner	SF104	CB2-H	2020/07/25	2021/07/24
EMI system	DEKRA	Version 1.0	CB2-H	NA	NA
Horn Antenna	Schwarzbeck	BBHA 9120D	639	2020/06/04	2021/06/03

## Spurious Emissions at Antenna Terminals / SR12-H

Instrument	Manufacturer	Model No.	Serial No.	Cal. Date	Next Cal. Date
Signal & Spectrum Analyzer	R&S	FSV40	101049	2020/03/30	2021/03/29
EXA Signal Analyzer	Keysight	N9010A	MY51440132	2020/02/21	2021/02/20
Spectrum Analyzer	Keysight	N9030B	MY57140404	2020/06/03	2021/06/02
Spectrum Analyzer	Keysight	N9010B	MY57110159	2020/04/15	2021/04/14
Wireless Conn. Tseter	R&S	CMW500	157118	2020/07/23	2021/07/22
Wideband Radio Communication Tester	R&S	CMW500	106071	2020/02/03	2021/02/02

## Frequency Stability / SR12-H

Instrument	Manufacturer	Model No.	Serial No.	Cal. Date	Next Cal. Date
Signal & Spectrum Analyzer	R&S	FSV40	101049	2020/03/30	2021/03/29
EXA Signal Analyzer	Keysight	N9010A	MY51440132	2020/02/21	2021/02/20
Spectrum Analyzer	Keysight	N9030B	MY57140404	2020/06/03	2021/06/02
Spectrum Analyzer	Keysight	N9010B	MY57110159	2020/04/15	2021/04/14
Wireless Conn. Tseter	R&S	CMW500	157118	2020/07/23	2021/07/22
Wideband Radio Communication Tester	R&S	CMW500	106071	2020/02/03	2021/02/02

Note: All equipment upon which need to calibrated are with calibration period of 1 year.

## 2.4. Measurement Uncertainty

Test Item	Uncertainty
RF Output Power	$\pm 1.27$ dB
Occupied Bandwidth	$\pm 10$ Hz
Peak To Average Ratio	Not exceed 13 dB
Spurious Emissions	$\pm 1.27$ dB for Conducted Measurement $\pm 3.2$ dB for Radiated Measurement
Spurious Emissions at Antenna Terminals	$\pm 3.2$ dB
Frequency Stability	$\pm 10$ Hz

### 3. RF Output Power

#### 3.1. Test Setup

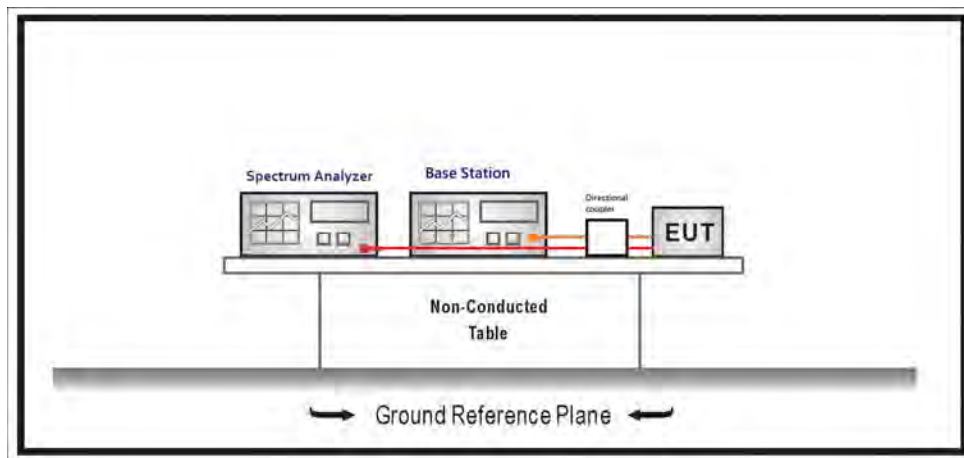

#### 3.2. Test Procedure

- The RF output of the transmitter was connected to base station simulator.
- The RF output of EUT was connected to the power meter by RF cable and attenuator. The path loss was compensated to the results for each measurement..
- Set EUT at maximum average power by base station emulator.
- Measure lowest, middle, and highest channels for each bandwidth and different modulation.

Effective Isotropic Radiated Power = Conducted Power(dBm) + Antenna Gain(dBi)

Effective Radiated Power = Conducted Power(dBm) + Antenna Gain(dBi) - 2.15dB

#### 3.3. Test Method

KDB 971168 D01 Power Meas License Digital Systems v03 sub-clause5.2.4

ANSI C63.26-2015 Sub-clause 5.2.4.2

### 3.4. Test Result

Product	Module		
Test Item	RF Output Power		
Test Mode	Mode 1: LTE Band 2/25		
Date of Test	2020/08/19	Test Site	SR12-H
Temperature(°C)	23	Humidity (%RH)	67

Band	Channel Freq. (MHz)	Modulation	RB No.	RB offset	MPR	Conducted Output Power (dBm)	RF Output Power (W) EIRP	Limit (W) EIRP
Band 25 1.4MHz	26047 1850.7	QPSK	1	0	0	20.99	0.316	2
		QPSK		2		21.01	0.317	2
		QPSK		5		20.98	0.315	2
		QPSK	6	0	1	19.95	0.248	2
		16-QAM	1	0	1	19.87	0.244	2
		16-QAM		2		19.93	0.247	2
		16-QAM		5		19.78	0.239	2
		16-QAM	6	0	2	19.05	0.202	2
	26365 1882.5	QPSK	1	0	0	21.29	0.338	2
		QPSK		2		21.09	0.323	2
		QPSK		5		21.28	0.337	2
		QPSK	6	0	1	20.26	0.267	2
		16-QAM	1	0	1	20.32	0.270	2
		16-QAM		2		20.47	0.280	2
		16-QAM		5		20.32	0.270	2
		16-QAM	6	0	2	19.18	0.208	2
	26683 1914.3	QPSK	1	0	0	21.22	0.333	2
		QPSK		2		21.24	0.334	2
		QPSK		5		21.19	0.330	2
		QPSK	6	0	1	20.24	0.265	2
		16-QAM	1	0	1	20.23	0.265	2
		16-QAM		2		20.35	0.272	2
		16-QAM		5		20.28	0.268	2
		16-QAM	6	0	2	19.21	0.209	2



Band	Channel Freq. (MHz)	Modulation	RB No.	RB offset	MPR	Conducted Output Power (dBm)	RF Output Power (W) EIRP	Limit (W) EIRP
Band 25 1.4MHz	26047 1850.7	64-QAM	1	0	0	19.83	0.242	2
		64-QAM		2		19.94	0.248	2
		64-QAM		5		19.86	0.243	2
		64-QAM	6	0	1	18.58	0.181	2
	26365 1882.5	64-QAM	1	0	0	20.05	0.254	2
		64-QAM		2		20.11	0.258	2
		64-QAM		5		20.08	0.256	2
		64-QAM	6	0	1	18.77	0.189	2
	26683 1914.3	64-QAM	1	0	0	20.06	0.255	2
		64-QAM		2		20.16	0.261	2
		64-QAM		5		20.05	0.254	2
		64-QAM	6	0	1	18.82	0.191	2

Note:

1. Measure Level (EIRP) = Reading Level (dBm) + Antenna Gain(dBi)
2. power (W)=  $(10^{(\text{power(dBm)}/10)}) * 10^{-3}$

Band	Channel Freq. (MHz)	Modulation	RB No.	RB offset	MPR	Conducted Output Power (dBm)	RF Output Power (W) EIRP	Limit (W) EIRP		
Band 25 3MHz	26055 1851.5	QPSK	1	0	0	21.00	0.316	2		
		QPSK		7		21.02			0.318	2
		QPSK		14		21.01			0.317	2
		QPSK	15	0	1	20.02	0.252	2		
		16-QAM	1	0	1	20.03	0.253	2		
		16-QAM		7		20.07			0.255	2
		16-QAM		14		20.01			0.252	2
		16-QAM	15	0	2	18.91	0.195	2		
	26365 1882.5	QPSK	1	0	0	20.98	0.315	2		
		QPSK		7		20.97			0.314	2
		QPSK		14		20.96			0.313	2
		QPSK	15	0	1	20.11	0.258	2		
		16-QAM	1	0	1	20.12	0.258	2		
		16-QAM		7		20.24			0.265	2
		16-QAM		14		20.13			0.259	2
		16-QAM	15	0	2	19.18	0.208	2		
	26675 1913.5	QPSK	1	0	0	21.36	0.344	2		
		QPSK		7		21.43			0.349	2
		QPSK		14		21.33			0.341	2
		QPSK	15	0	1	20.34	0.272	2		
		16-QAM	1	0	1	20.38	0.274	2		
		16-QAM		7		20.49			0.281	2
		16-QAM		14		20.37			0.274	2
		16-QAM	15	0	2	19.29	0.213	2		

Band	Channel Freq. (MHz)	Modulation	RB No.	RB offset	MPR	Conducted Output Power (dBm)	RF Output Power (W) EIRP	Limit (W) EIRP
Band 25 3MHz	26055 1851.5	64-QAM	1	0	0	19.82	0.241	2
		64-QAM		7		19.92	0.247	2
		64-QAM		14		19.79	0.239	2
		64-QAM	15	0	1	18.44	0.175	2
	26365 1882.5	64-QAM	1	0	0	19.63	0.231	2
		64-QAM		7		19.96	0.249	2
		64-QAM		14		19.62	0.230	2
		64-QAM	15	0	1	18.37	0.173	2
	26675 1913.5	64-QAM	1	0	0	20.03	0.253	2
		64-QAM		7		20.13	0.259	2
		64-QAM		14		19.99	0.251	2
		64-QAM	15	0	1	18.74	0.188	2

Note:

1. Measure Level (EIRP) = Reading Level (dBm) + Antenna Gain(dBi)
2. power (W)=  $(10^{(\text{power(dBm)}/10)}) * 10^{-3}$

Band	Channel Freq. (MHz)	Modulation	RB No.	RB offset	MPR	Conducted Output Power (dBm)	RF Output Power (W) EIRP	Limit (W) EIRP
Band 25 5MHz	26065 1852.5	QPSK	1	0	0	21.14	0.327	2
		QPSK		12		21.18	0.330	2
		QPSK		24		21.08	0.322	2
		QPSK	25	0	1	20.05	0.254	2
		16-QAM	1	0	1	20.20	0.263	2
		16-QAM		12		20.33	0.271	2
		16-QAM		24		20.25	0.266	2
	16-QAM	25	0	2	19.08	0.203	2	
	26365 1882.5	QPSK	1	0	0	21.27	0.337	2
		QPSK		12		21.31	0.340	2
		QPSK		24		21.21	0.332	2
		QPSK	25	0	1	20.11	0.258	2
		16-QAM	1	0	1	20.13	0.259	2
		16-QAM		12		20.19	0.262	2
		16-QAM		24		20.08	0.256	2
	16-QAM	25	0	2	19.17	0.207	2	
	26665 1912.5	QPSK	1	0	0	21.50	0.355	2
		QPSK		12		21.58	0.361	2
		QPSK		24		21.47	0.352	2
		QPSK	25	0	1	20.45	0.279	2
		16-QAM	1	0	1	20.65	0.292	2
		16-QAM		12		20.75	0.299	2
		16-QAM		24		20.62	0.290	2
	16-QAM	25	0	2	19.35	0.216	2	

Band	Channel Freq. (MHz)	Modulation	RB No.	RB offset	MPR	Conducted Output Power (dBm)	RF Output Power (W) EIRP	Limit (W) EIRP
Band 25 5MHz	26065 1852.5	64-QAM	1	0	0	19.98	0.250	2
		64-QAM		12		20.06	0.255	2
		64-QAM		24		19.95	0.248	2
		64-QAM	25	0	1	18.53	0.179	2
	26365 1882.5	64-QAM	1	0	0	19.87	0.244	2
		64-QAM		12		19.92	0.247	2
		64-QAM		24		19.86	0.243	2
		64-QAM	25	0	1	18.67	0.185	2
	26665 1912.5	64-QAM	1	0	0	19.88	0.244	2
		64-QAM		12		19.97	0.249	2
		64-QAM		24		19.92	0.247	2
		64-QAM	25	0	1	18.69	0.186	2

Note:

1. Measure Level (EIRP) = Reading Level (dBm) + Antenna Gain(dBi)
2. power (W)=  $(10^{(\text{power(dBm)}/10)}) * 10^{-3}$

Band	Channel Freq. (MHz)	Modulation	RB No.	RB offset	MPR	Conducted Output Power (dBm)	RF Output Power (W) EIRP	Limit (W) EIRP
Band 25 10MHz	26090 1855	QPSK	1	0	0	21.05	0.320	2
		QPSK		24		21.02	0.318	2
		QPSK		49		20.98	0.315	2
		QPSK	50	0	1	20.17	0.261	2
		16-QAM	1	0	1	20.24	0.265	2
		16-QAM		24		20.25	0.266	2
		16-QAM		49		20.24	0.265	2
		16-QAM		50		0	2	19.15
	26365 1882.5	QPSK	1	0	0	21.19	0.330	2
		QPSK		24		21.17	0.329	2
		QPSK		49		21.12	0.325	2
		QPSK	50	0	1	20.15	0.260	2
		16-QAM	1	0	1	20.31	0.270	2
		16-QAM		24		20.24	0.265	2
		16-QAM		49		20.21	0.264	2
		16-QAM		50		0	2	19.14
	26640 1910	QPSK	1	0	0	21.26	0.336	2
		QPSK		24		21.31	0.340	2
		QPSK		49		21.28	0.337	2
		QPSK	50	0	1	20.46	0.279	2
		16-QAM	1	0	1	20.58	0.287	2
		16-QAM		24		20.51	0.282	2
		16-QAM		49		20.50	0.282	2
		16-QAM		50		0	2	19.45

Band	Channel Freq. (MHz)	Modulation	RB No.	RB offset	MPR	Conducted Output Power (dBm)	RF Output Power (W) EIRP	Limit (W) EIRP
Band 25 10MHz	26090 1855	64-QAM	1	0	0	19.93	0.247	2
		64-QAM		24		20.02	0.252	2
		64-QAM		49		19.95	0.248	2
		64-QAM	50	0	1	18.46	0.176	2
	26365 1882.5	64-QAM	1	0	0	19.84	0.242	2
		64-QAM		24		19.91	0.246	2
		64-QAM		49		19.79	0.239	2
		64-QAM	50	0	1	18.42	0.175	2
	26640 1910	64-QAM	1	0	0	18.86	0.193	2
		64-QAM		24		19.96	0.249	2
		64-QAM		49		18.85	0.193	2
		64-QAM	50	0	1	18.47	0.177	2

Note:

1. Measure Level (EIRP) = Reading Level (dBm) + Antenna Gain(dBi)
2. power (W)=  $(10^{(\text{power(dBm)}/10)}) * 10^{-3}$

Band	Channel Freq. (MHz)	Modulation	RB No.	RB offset	MPR	Conducted Output Power (dBm)	RF Output Power (W) EIRP	Limit (W) EIRP
Band 25 15MHz	26115 1857.5	QPSK	1	0	0	21.14	0.327	2
		QPSK		37		21.03	0.318	2
		QPSK		74		21.12	0.325	2
		QPSK	75	0	1	21.07	0.321	2
		16-QAM	1	0	1	20.37	0.274	2
		16-QAM		37		20.28	0.268	2
		16-QAM		74		20.42	0.277	2
	16-QAM	75	0	2	19.14	0.206	2	
	26365 1882.5	QPSK	1	0	0	21.26	0.336	2
		QPSK		37		21.23	0.333	2
		QPSK		74		21.21	0.332	2
		QPSK	75	0	1	20.17	0.261	2
		16-QAM	1	0	1	20.42	0.277	2
		16-QAM		37		20.27	0.267	2
		16-QAM		74		20.23	0.265	2
	16-QAM	75	0	2	19.17	0.207	2	
	26615 1907.5	QPSK	1	0	0	21.59	0.362	2
		QPSK		37		21.48	0.353	2
		QPSK		74		21.36	0.344	2
		QPSK	75	0	1	20.58	0.287	2
		16-QAM	1	0	1	20.88	0.308	2
		16-QAM		37		20.83	0.304	2
		16-QAM		74		20.85	0.305	2
	16-QAM	75	0	2	19.58	0.228	2	



Band	Channel Freq. (MHz)	Modulation	RB No.	RB offset	MPR	Conducted Output Power (dBm)	RF Output Power (W) EIRP	Limit (W) EIRP
Band 25 15MHz	26115 1857.5	64-QAM	1	0	0	19.96	0.249	2
		64-QAM		37		20.04	0.254	2
		64-QAM		74		19.91	0.246	2
		64-QAM	75	0	1	18.49	0.177	2
	26365 1882.5	64-QAM	1	0	0	19.89	0.245	2
		64-QAM		37		19.93	0.247	2
		64-QAM		74		19.83	0.242	2
		64-QAM	75	0	1	18.43	0.175	2
	26615 1907.5	64-QAM	1	0	0	19.88	0.244	2
		64-QAM		37		19.98	0.250	2
		64-QAM		74		19.86	0.243	2
		64-QAM	75	0	1	18.47	0.177	2

Note:

1. Measure Level (EIRP) = Reading Level (dBm) + Antenna Gain(dBi)
2. power (W)=  $(10^{(\text{power(dBm)}/10)}) * 10^{-3}$

Band	Channel Freq. (MHz)	Modulation	RB No.	RB offset	MPR	Conducted Output Power (dBm)	RF Output Power (W) EIRP	Limit (W) EIRP
Band 25 20MHz	26140 1860	QPSK	1	0	0	21.36	0.344	2
		QPSK		49		21.31	0.340	2
		QPSK		99		21.17	0.329	2
		QPSK	100	0	1	20.25	0.266	2
		16-QAM	1	0	1	20.21	0.264	2
		16-QAM		49		20.09	0.256	2
		16-QAM		99		20.02	0.252	2
		16-QAM	100	0	2	19.23	0.210	2
	26365 1882.5	QPSK	1	0	0	21.62	0.365	2
		QPSK		49		21.02	0.318	2
		QPSK		99		20.91	0.310	2
		QPSK	100	0	1	20.19	0.262	2
		16-QAM	1	0	1	20.46	0.279	2
		16-QAM		49		20.41	0.276	2
		16-QAM		99		20.27	0.267	2
		16-QAM	100	0	2	19.20	0.209	2
	26590 1905	QPSK	1	0	0	21.60	0.363	2
		QPSK		49		21.43	0.349	2
		QPSK		99		21.49	0.354	2
		QPSK	100	0	1	20.62	0.290	2
		16-QAM	1	0	1	20.65	0.292	2
		16-QAM		49		20.56	0.286	2
		16-QAM		99		20.61	0.289	2
		16-QAM	100	0	2	19.61	0.230	2

Band	Channel Freq. (MHz)	Modulation	RB No.	RB offset	MPR	Conducted Output Power (dBm)	RF Output Power (W) EIRP	Limit (W) EIRP
Band 25 20MHz	26140 1860	64-QAM	1	0	0	20.18	0.262	2
		64-QAM		49		20.08	0.256	2
		64-QAM		99		19.89	0.245	2
		64-QAM	100	0	1	18.59	0.182	2
	26365 1882.5	64-QAM	1	0	0	20.08	0.256	2
		64-QAM		49		19.89	0.245	2
		64-QAM		99		19.80	0.240	2
		64-QAM	100	0	1	18.55	0.180	2
	26590 1905	64-QAM	1	0	0	20.06	0.255	2
		64-QAM		49		19.95	0.248	2
		64-QAM		99		19.88	0.244	2
		64-QAM	100	0	1	18.57	0.181	2

Note:

1. Measure Level (EIRP) = Reading Level (dBm) + Antenna Gain(dBi)
2. power (W)=  $(10^{(\text{power(dBm)}/10)}) * 10^{-3}$

Product	Module		
Test Item	RF Output Power		
Test Mode	Mode 2: LTE Band 4/66		
Date of Test	2020/08/19	Test Site	SR12-H
Temperature(°C)	23	Humidity (%RH)	67

Band	Channel Freq. (MHz)	Modulation	RB No.	RB offset	MPR	Conducted Output Power (dBm)	RF Output Power (W) EIRP	Limit (W) EIRP
Band 66 1.4MHz	131979 1710.7	QPSK	1	0	0	21.39	0.346	1
		QPSK		2		21.49	0.354	1
		QPSK		5		21.36	0.344	1
		QPSK	6	0	1	20.41	0.276	1
		16-QAM	1	0	1	20.21	0.264	1
		16-QAM		2		20.29	0.269	1
		16-QAM		5		20.23	0.265	1
		16-QAM	6	0	2	19.41	0.219	1
	132322 1745	QPSK	1	0	0	21.54	0.358	1
		QPSK		2		21.65	0.367	1
		QPSK		5		21.57	0.361	1
		QPSK	6	0	1	20.56	0.286	1
		16-QAM	1	0	1	20.55	0.285	1
		16-QAM		2		20.58	0.287	1
		16-QAM		5		20.57	0.286	1
		16-QAM	6	0	2	19.43	0.220	1
	132665 1779.3	QPSK	1	0	0	21.21	0.332	1
		QPSK		2		21.19	0.330	1
		QPSK		5		21.18	0.330	1
		QPSK	6	0	1	20.28	0.268	1
		16-QAM	1	0	1	20.01	0.252	1
		16-QAM		2		20.06	0.255	1
		16-QAM		5		19.95	0.248	1
		16-QAM	6	0	2	19.27	0.212	1

Band	Channel Freq. (MHz)	Modulation	RB No.	RB offset	MPR	Conducted Output Power (dBm)	RF Output Power (W) EIRP	Limit (W) EIRP
Band 66 1.4MHz	131979 1710.7	64-QAM	1	0	0	20.06	0.255	1
		64-QAM		2		20.14	0.259	1
		64-QAM		5		20.11	0.258	1
		64-QAM	6	0	1	18.83	0.192	1
	132322 1745	64-QAM	1	0	0	20.09	0.256	1
		64-QAM		2		20.21	0.264	1
		64-QAM		5		20.10	0.257	1
		64-QAM	6	0	1	18.86	0.193	1
	132665 1779.3	64-QAM	1	0	0	20.13	0.259	1
		64-QAM		2		20.23	0.265	1
		64-QAM		5		20.17	0.261	1
		64-QAM	6	0	1	18.96	0.198	1

Note:

1. Measure Level (EIRP) = Reading Level (dBm) + Antenna Gain(dBi)
2. power (W)=  $(10^{(\text{power(dBm)}/10)}) * 10^{-3}$

Band	Channel Freq. (MHz)	Modulation	RB No.	RB offset	MPR	Conducted Output Power (dBm)	RF Output Power (W) EIRP	Limit (W) EIRP
Band 66 3MHz	131987 1711.5	QPSK	1	0	0	21.24	0.334	1
		QPSK		7		21.37	0.344	1
		QPSK		14		21.25	0.335	1
		QPSK	15	0	1	20.54	0.284	1
		16-QAM	1	0	1	20.96	0.313	1
		16-QAM		7		20.97	0.314	1
		16-QAM		14		20.87	0.307	1
		16-QAM	15	0	2	20.90	0.309	1
	132322 1745	QPSK	1	0	0	21.74	0.375	1
		QPSK		7		21.77	0.378	1
		QPSK		14		21.69	0.371	1
		QPSK	15	0	1	20.66	0.292	1
		16-QAM	1	0	1	20.56	0.286	1
		16-QAM		7		20.52	0.283	1
		16-QAM		14		20.48	0.281	1
		16-QAM	15	0	2	19.61	0.230	1
	132657 1778.5	QPSK	1	0	0	21.39	0.346	1
		QPSK		7		21.38	0.345	1
		QPSK		14		21.37	0.344	1
		QPSK	15	0	1	20.41	0.276	1
		16-QAM	1	0	1	20.47	0.280	1
		16-QAM		7		20.45	0.279	1
		16-QAM		14		20.43	0.277	1
		16-QAM	15	0	2	19.46	0.222	1

Band	Channel Freq. (MHz)	Modulation	RB No.	RB offset	MPR	Conducted Output Power (dBm)	RF Output Power (W) EIRP	Limit (W) EIRP
Band 66 3MHz	131987 1711.5	64-QAM	1	0	0	20.19	0.262	1
		64-QAM		7		20.28	0.268	1
		64-QAM		14		20.12	0.258	1
		64-QAM	15	0	1	18.83	0.192	1
	132322 1745	64-QAM	1	0	0	20.23	0.265	1
		64-QAM		7		20.34	0.272	1
		64-QAM		14		20.17	0.261	1
		64-QAM	15	0	1	18.89	0.195	1
	132657 1778.5	64-QAM	1	0	0	20.24	0.265	1
		64-QAM		7		20.37	0.274	1
		64-QAM		14		20.21	0.264	1
		64-QAM	15	0	1	18.91	0.195	1

Note:

1. Measure Level (EIRP) = Reading Level (dBm) + Antenna Gain(dBi)
2. power (W)=  $(10^{(\text{power(dBm)}/10)}) * 10^{-3}$

Band	Channel Freq. (MHz)	Modulation	RB No.	RB offset	MPR	Conducted Output Power (dBm)	RF Output Power (W) EIRP	Limit (W) EIRP	
Band 66 5MHz	131997 1712.5	QPSK	1	0	0	21.39	0.346	1	
		QPSK		12		21.41			0.348
		QPSK		24		21.29			0.338
		QPSK	16-QAM	25	0	1	20.53	0.284	1
		16-QAM		1	0	1	20.42	0.277	1
		16-QAM			12		20.56	0.286	
		16-QAM			24		20.41	0.276	
		16-QAM	25	0	2	19.56	0.227	1	
	132322 1745	QPSK	1	0	0	21.71	0.372	1	
		QPSK		12		21.77			0.378
		QPSK		24		21.67			0.369
		QPSK	16-QAM	25	0	1	20.71	0.296	1
		16-QAM		1	0	1	21.09	0.323	1
		16-QAM			12		21.12	0.325	
		16-QAM			24		21.07	0.321	
		16-QAM	25	0	2	19.67	0.233	1	
	132647 1777.5	QPSK	1	0	0	21.35	0.343	1	
		QPSK		12		21.39			0.346
		QPSK		24		21.29			0.338
		QPSK	16-QAM	25	0	1	20.42	0.277	1
		16-QAM		1	0	1	20.52	0.283	1
		16-QAM			12		20.49	0.281	
		16-QAM			24		20.41	0.276	
		16-QAM	25	0	2	19.49	0.223	1	



Band	Channel Freq. (MHz)	Modulation	RB No.	RB offset	MPR	Conducted Output Power (dBm)	RF Output Power (W) EIRP	Limit (W) EIRP
Band 66 5MHz	131997 1712.5	64-QAM	1	0	0	20.35	0.272	1
		64-QAM		12		20.20	0.263	1
		64-QAM		24		20.32	0.270	1
		64-QAM	25	0	1	18.87	0.194	1
	132322 1745	64-QAM	1	0	0	20.38	0.274	1
		64-QAM		12		20.24	0.265	1
		64-QAM		24		20.36	0.273	1
		64-QAM	25	0	1	18.89	0.195	1
	132647 1777.5	64-QAM	1	0	0	20.40	0.275	1
		64-QAM		12		20.31	0.270	1
		64-QAM		24		20.33	0.271	1
		64-QAM	25	0	1	18.92	0.196	1

Note:

1. Measure Level (EIRP) = Reading Level (dBm) + Antenna Gain(dBi)
2. power (W)=  $(10^{(\text{power(dBm)}/10)}) * 10^{-3}$

Band	Channel Freq. (MHz)	Modulation	RB No.	RB offset	MPR	Conducted Output Power (dBm)	RF Output Power (W) EIRP	Limit (W) EIRP			
Band 66 10MHz	132022 1715	QPSK	1	0	0	21.34	0.342	1			
		QPSK		24		21.19			0.330	1	
		QPSK		49		21.32			0.340	1	
		QPSK	50	0	1	20.50	0.282	1			
		16-QAM		0		21.00			0.316	1	
		16-QAM		1		24			20.87	0.307	1
		16-QAM				49			20.96	0.313	1
		16-QAM	50	0	2	19.52	0.225	1			
	132322 1745	QPSK	1	0	0	21.79	0.379	1			
		QPSK		24		21.74			0.375	1	
		QPSK		49		21.70			0.372	1	
		QPSK	50	0	1	20.71	0.296	1			
		16-QAM		0		20.59			0.288	1	
		16-QAM		1		24			20.57	0.286	1
		16-QAM				49			20.59	0.288	1
		16-QAM	50	0	2	19.72	0.236	1			
	132622 1775	QPSK	1	0	0	21.51	0.356	1			
		QPSK		24		21.42			0.348	1	
		QPSK		49		21.39			0.346	1	
		QPSK	50	0	1	20.47	0.280	1			
		16-QAM		0		20.54			0.284	1	
		16-QAM		1		24			20.45	0.279	1
		16-QAM				49			20.37	0.274	1
		16-QAM	50	0	2	19.54	0.226	1			

Band	Channel Freq. (MHz)	Modulation	RB No.	RB offset	MPR	Conducted Output Power (dBm)	RF Output Power (W) EIRP	Limit (W) EIRP
Band 66 10MHz	132022 1715	64-QAM	1	0	0	20.42	0.277	1
		64-QAM		24		20.33	0.271	1
		64-QAM		49		20.35	0.272	1
		64-QAM	50	0	1	18.92	0.196	1
	132322 1745	64-QAM	1	0	0	20.46	0.279	1
		64-QAM		24		20.35	0.272	1
		64-QAM		49		20.38	0.274	1
		64-QAM	50	0	1	18.94	0.197	1
	132622 1775	64-QAM	1	0	0	20.51	0.282	1
		64-QAM		24		20.38	0.274	1
		64-QAM		49		20.40	0.275	1
		64-QAM	50	0	1	18.99	0.199	1

Note:

1. Measure Level (EIRP) = Reading Level (dBm) + Antenna Gain(dBi)
2. power (W)=  $(10^{(\text{power(dBm)}/10)}) * 10^{-3}$

Band	Channel Freq. (MHz)	Modulation	RB No.	RB offset	MPR	Conducted Output Power (dBm)	RF Output Power (W) EIRP	Limit (W) EIRP
Band 66 15MHz	132047 1717.5	QPSK	1	0	0	21.39	0.346	1
		QPSK		37		21.38		
		QPSK		74		21.40		
		QPSK	75	0	1	20.46	0.279	1
		16-QAM	1	0	1	20.99	0.316	1
		16-QAM		37		20.97		
		16-QAM		74		21.01		
		16-QAM	75	0	2	19.54	0.226	1
	132322 1745	QPSK	1	0	0	21.77	0.378	1
		QPSK		37		21.74		
		QPSK		74		21.73		
		QPSK	75	0	1	20.70	0.295	1
		16-QAM	1	0	1	20.56	0.286	1
		16-QAM		37		20.54		
		16-QAM		74		20.57		
		16-QAM	75	0	2	19.76	0.238	1
	132597 1772.5	QPSK	1	0	0	21.56	0.360	1
		QPSK		37		21.38		
		QPSK		74		21.37		
		QPSK	75	0	1	20.48	0.281	1
		16-QAM	1	0	1	20.82	0.303	1
		16-QAM		37		20.63		
		16-QAM		74		20.65		
		16-QAM	75	0	2	19.51	0.224	1

Band	Channel Freq. (MHz)	Modulation	RB No.	RB offset	MPR	Conducted Output Power (dBm)	RF Output Power (W) EIRP	Limit (W) EIRP
Band 66 15MHz	132047 1717.5	64-QAM	1	0	0	20.28	0.268	1
		64-QAM		37		20.22	0.264	1
		64-QAM		74		20.24	0.265	1
		64-QAM	75	0	1	19.01	0.200	1
	132322 1745	64-QAM	1	0	0	20.34	0.272	1
		64-QAM		37		20.27	0.267	1
		64-QAM		74		20.29	0.269	1
		64-QAM	75	0	1	19.04	0.201	1
	132597 1772.5	64-QAM	1	0	0	20.37	0.274	1
		64-QAM		37		20.29	0.269	1
		64-QAM		74		20.32	0.270	1
		64-QAM	75	0	1	19.05	0.202	1

Note:

1. Measure Level (EIRP) = Reading Level (dBm) + Antenna Gain(dBi)
2. power (W)=  $(10^{(\text{power(dBm)}/10)}) * 10^{-3}$

Band	Channel Freq. (MHz)	Modulation	RB No.	RB offset	MPR	Conducted Output Power (dBm)	RF Output Power (W) EIRP	Limit (W) EIRP
Band 66 20MHz	132072 1720	QPSK	1	0	0	21.52	0.356	1
		QPSK		49		21.35	0.343	1
		QPSK		99		21.40	0.347	1
		QPSK	100	0	1	20.56	0.286	1
		16-QAM	1	0	1	20.99	0.316	1
		16-QAM		49		20.88	0.308	1
		16-QAM		99		21.05	0.320	1
		16-QAM	100	0	2	19.61	0.230	1
	132322 1745	QPSK	1	0	0	21.85	0.385	1
		QPSK		49		21.81	0.381	1
		QPSK		99		21.83	0.383	1
		QPSK	100	0	1	20.77	0.300	1
		16-QAM	1	0	1	20.81	0.303	1
		16-QAM		49		20.69	0.294	1
		16-QAM		99		20.75	0.299	1
		16-QAM	100	0	2	19.81	0.240	1
	132572 1770	QPSK	1	0	0	21.59	0.362	1
		QPSK		49		21.33	0.341	1
		QPSK		99		21.29	0.338	1
		QPSK	100	0	1	20.57	0.286	1
		16-QAM	1	0	1	20.96	0.313	1
		16-QAM		49		20.64	0.291	1
		16-QAM		99		20.61	0.289	1
		16-QAM	100	0	2	19.58	0.228	1

Band	Channel Freq. (MHz)	Modulation	RB No.	RB offset	MPR	Conducted Output Power (dBm)	RF Output Power (W) EIRP	Limit (W) EIRP
Band 66 20MHz	132072 1720	64-QAM	1	0	0	20.42	0.277	1
		64-QAM		49		20.25	0.266	1
		64-QAM		99		20.29	0.269	1
		64-QAM	100	0	1	19.00	0.200	1
	132322 1745	64-QAM	1	0	0	20.47	0.280	1
		64-QAM		49		20.23	0.265	1
		64-QAM		99		20.24	0.265	1
		64-QAM	100	0	1	19.02	0.200	1
	132572 1770	64-QAM	1	0	0	20.52	0.283	1
		64-QAM		49		20.35	0.272	1
		64-QAM		99		20.39	0.275	1
		64-QAM	100	0	1	19.07	0.203	1

Note:

1. Measure Level (EIRP) = Reading Level (dBm) + Antenna Gain(dBi)
2. power (W)=  $(10^{(\text{power(dBm)}/10)}) * 10^{-3}$

Product	Module		
Test Item	RF Output Power		
Test Mode	Mode 3: LTE Band 5/26 (Part 22)		
Date of Test	2020/08/19	Test Site	SR12-H
Temperature(°C)	23	Humidity (%RH)	67

Band	Channel Freq. (MHz)	Modulation	RB No.	RB offset	MPR	Conducted Output Power (dBm)	RF Output Power (W) ERP	Limit (W) ERP
Band 26 1.4MHz	26797 824.7	QPSK	1	0	0	22.37	0.167	7
		QPSK		2		22.38	0.167	7
		QPSK		5		22.33	0.165	7
		QPSK	6	0	1	21.37	0.132	7
		16-QAM	1	0	1	21.05	0.123	7
		16-QAM		2		21.16	0.126	7
		16-QAM		5		21.10	0.124	7
		16-QAM		6		0	2	20.35
	26915 836.5	QPSK	1	0	0	22.51	0.172	7
		QPSK		2		22.56	0.174	7
		QPSK		5		22.62	0.177	7
		QPSK	6	0	1	21.57	0.139	7
		16-QAM	1	0	1	21.40	0.133	7
		16-QAM		2		21.47	0.136	7
		16-QAM		5		21.38	0.133	7
		16-QAM		6		0	2	20.55
	27033 848.3	QPSK	1	0	0	22.47	0.171	7
		QPSK		2		22.49	0.171	7
		QPSK		5		22.46	0.170	7
		QPSK	6	0	1	21.40	0.133	7
		16-QAM	1	0	1	21.46	0.135	7
		16-QAM		2		21.49	0.136	7
		16-QAM		5		21.48	0.136	7
		16-QAM		6		0	2	20.32



Band	Channel Freq. (MHz)	Modulation	RB No.	RB offset	MPR	Conducted Output Power (dBm)	RF Output Power (W) ERP	Limit (W) ERP
Band 26 1.4MHz	26797 824.7	64-QAM	1	0	0	21.10	0.124	7
		64-QAM		2		21.24	0.129	7
		64-QAM		5		21.08	0.124	7
		64-QAM	6	0	1	19.79	0.092	7
	26915 836.5	64-QAM	1	0	0	21.13	0.125	7
		64-QAM		2		21.25	0.129	7
		64-QAM		5		21.11	0.125	7
		64-QAM	6	0	1	19.78	0.092	7
	27033 848.3	64-QAM	1	0	0	21.05	0.123	7
		64-QAM		2		21.18	0.127	7
		64-QAM		5		21.01	0.122	7
		64-QAM	6	0	1	19.74	0.091	7

Note:

1. Measure Level (ERP) = Reading Level (dBm) + Antenna Gain(dBi)-2.15dB
2. power (W)=  $(10^{(\text{power(dBm)}/10)}) * 10^{-3}$

Band	Channel Freq. (MHz)	Modulation	RB No.	RB offset	MPR	Conducted Output Power (dBm)	RF Output Power (W) ERP	Limit (W) ERP
Band 26 3MHz	26805 825.5	QPSK	1	0	0	22.33	0.165	7
		QPSK		7		22.29	0.164	7
		QPSK		14		22.27	0.163	7
		QPSK	15	0	1	21.44	0.135	7
		16-QAM	1	0	1	21.93	0.151	7
		16-QAM		7		21.94	0.151	7
		16-QAM		14		21.87	0.149	7
		16-QAM	15	0	2	20.58	0.110	7
	26915 836.5	QPSK	1	0	0	22.66	0.178	7
		QPSK		7		22.61	0.176	7
		QPSK		14		22.60	0.176	7
		QPSK	15	0	1	21.63	0.141	7
		16-QAM	1	0	1	21.51	0.137	7
		16-QAM		7		21.49	0.136	7
		16-QAM		14		21.40	0.133	7
		16-QAM	15	0	2	20.57	0.110	7
	27025 847.5	QPSK	1	0	0	22.57	0.175	7
		QPSK		7		22.53	0.173	7
		QPSK		14		22.51	0.172	7
		QPSK	15	0	1	21.52	0.137	7
		16-QAM	1	0	1	21.58	0.139	7
		16-QAM		7		21.51	0.137	7
		16-QAM		14		21.48	0.136	7
		16-QAM	15	0	2	20.54	0.109	7

Band	Channel Freq. (MHz)	Modulation	RB No.	RB offset	MPR	Conducted Output Power (dBm)	RF Output Power (W) ERP	Limit (W) ERP
Band 26 3MHz	26805 825.5	64-QAM	1	0	0	21.27	0.129	7
		64-QAM		7		21.16	0.126	7
		64-QAM		14		21.13	0.125	7
		64-QAM	15	0	1	19.83	0.093	7
	26915 836.5	64-QAM	1	0	0	21.29	0.130	7
		64-QAM		7		21.22	0.128	7
		64-QAM		14		21.17	0.126	7
		64-QAM	15	0	1	19.86	0.094	7
	27025 847.5	64-QAM	1	0	0	21.24	0.129	7
		64-QAM		7		21.18	0.127	7
		64-QAM		14		21.12	0.125	7
		64-QAM	15	0	1	19.88	0.094	7

Note:

1. Measure Level (ERP) = Reading Level (dBm) + Antenna Gain(dBi)-2.15dB
2. power (W)=  $(10^{(\text{power(dBm)}/10)}) * 10^{-3}$

Band	Channel Freq. (MHz)	Modulation	RB No.	RB offset	MPR	Conducted Output Power (dBm)	RF Output Power (W) ERP	Limit (W) ERP			
Band 26 5MHz	26815 826.5	QPSK	1	0	0	22.28	0.163	7			
		QPSK		12		22.33			0.165	7	
		QPSK		24		22.34			0.166	7	
		QPSK	25	0	1	21.30	0.130	7			
		16-QAM		0		21.24			0.129	7	
		16-QAM		1		12			21.37	0.132	7
		16-QAM				24			21.36	0.132	7
		16-QAM	25	0	2	20.37	0.105	7			
	26915 836.5	QPSK	1	0	0	22.61	0.176	7			
		QPSK		12		22.62			0.177	7	
		QPSK		24		22.53			0.173	7	
		QPSK	25	0	1	21.61	0.140	7			
		16-QAM		0		22.03			0.154	7	
		16-QAM		1		12			22.06	0.155	7
		16-QAM				24			21.95	0.151	7
		16-QAM	25	0	2	20.58	0.110	7			
	27015 846.5	QPSK	1	0	0	22.48	0.171	7			
		QPSK		12		22.54			0.173	7	
		QPSK		24		22.48			0.171	7	
		QPSK	25	0	1	21.64	0.141	7			
		16-QAM		0		21.61			0.140	7	
		16-QAM		1		12			21.71	0.143	7
		16-QAM				24			21.62	0.140	7
		16-QAM	25	0	2	20.71	0.114	7			

Band	Channel Freq. (MHz)	Modulation	RB No.	RB offset	MPR	Conducted Output Power (dBm)	RF Output Power (W) ERP	Limit (W) ERP
Band 26 5MHz	26815 826.5	64-QAM	1	0	0	21.30	0.130	7
		64-QAM		12		21.25	0.129	7
		64-QAM		24		21.22	0.128	7
		64-QAM	25	0	1	19.90	0.094	7
	26915 836.5	64-QAM	1	0	0	21.32	0.131	7
		64-QAM		12		21.24	0.129	7
		64-QAM		24		21.26	0.129	7
		64-QAM	25	0	1	19.85	0.093	7
	27015 846.5	64-QAM	1	0	0	21.29	0.130	7
		64-QAM		12		21.23	0.128	7
		64-QAM		24		21.27	0.129	7
		64-QAM	25	0	1	19.85	0.093	7

Note:

1. Measure Level (ERP) = Reading Level (dBm) + Antenna Gain(dBi)-2.15dB
2. power (W)=  $(10^{(\text{power(dBm)}/10)}) * 10^{-3}$

Band	Channel Freq. (MHz)	Modulation	RB No.	RB offset	MPR	Conducted Output Power (dBm)	RF Output Power (W) ERP	Limit (W) ERP
Band 26 10MHz	26840 829	QPSK	1	0	0	22.32	0.165	7
		QPSK		24		22.34	0.166	7
		QPSK		49		22.28	0.163	7
		QPSK	50	0	1	21.52	0.137	7
		16-QAM	1	0	1	21.97	0.152	7
		16-QAM		24		21.99	0.153	7
		16-QAM		49		21.85	0.148	7
		16-QAM	50	0	2	20.56	0.110	7
	26915 836.5	QPSK	1	0	0	22.59	0.175	7
		QPSK		24		22.62	0.177	7
		QPSK		49		22.59	0.175	7
		QPSK	50	0	1	21.63	0.141	7
		16-QAM	1	0	1	21.41	0.134	7
		16-QAM		24		21.44	0.135	7
		16-QAM		49		21.42	0.134	7
		16-QAM	50	0	2	20.58	0.110	7
	26990 844	QPSK	1	0	0	22.45	0.170	7
		QPSK		24		22.48	0.171	7
		QPSK		49		22.47	0.171	7
		QPSK	50	0	1	21.48	0.136	7
		16-QAM	1	0	1	21.40	0.133	7
		16-QAM		24		21.43	0.134	7
		16-QAM		49		21.41	0.134	7
		16-QAM	50	0	2	20.51	0.109	7

Band	Channel Freq. (MHz)	Modulation	RB No.	RB offset	MPR	Conducted Output Power (dBm)	RF Output Power (W) ERP	Limit (W) ERP
Band 26 10MHz	26840 829	64-QAM	1	0	0	21.21	0.128	7
		64-QAM		24		21.10	0.124	7
		64-QAM		49		21.13	0.125	7
		64-QAM	50	0	1	19.85	0.093	7
	26915 836.5	64-QAM	1	0	0	21.24	0.129	7
		64-QAM		24		21.12	0.125	7
		64-QAM		49		21.18	0.127	7
		64-QAM	50	0	1	19.88	0.094	7
	26990 844	64-QAM	1	0	0	21.15	0.126	7
		64-QAM		24		21.11	0.125	7
		64-QAM		49		21.06	0.123	7
		64-QAM	50	0	1	19.91	0.095	7

Note:

1. Measure Level (ERP) = Reading Level (dBm) + Antenna Gain(dBi)-2.15dB
2. power (W)=  $(10^{(\text{power(dBm)}/10)}) * 10^{-3}$

Band	Channel Freq. (MHz)	Modulation	RB No.	RB offset	MPR	Conducted Output Power (dBm)	RF Output Power (W) ERP	Limit (W) ERP
Band 26 15MHz	26865 831.5	QPSK	1	0	0	22.39	0.167	7
		QPSK		37		22.29	0.164	7
		QPSK		74		22.37	0.167	7
		QPSK	75	0	1	21.44	0.135	7
		16-QAM	1	0	1	21.95	0.151	7
		16-QAM		37		22.05	0.155	7
		16-QAM		74		21.92	0.150	7
		16-QAM	75	0	2	20.50	0.108	7
	26915 836.5	QPSK	1	0	0	22.67	0.179	7
		QPSK		37		22.64	0.177	7
		QPSK		74		22.58	0.175	7
		QPSK	75	0	1	21.60	0.140	7
		16-QAM	1	0	1	21.47	0.136	7
		16-QAM		37		21.50	0.136	7
		16-QAM		74		21.44	0.135	7
		16-QAM	75	0	2	20.66	0.112	7
	26965 841.5	QPSK	1	0	0	22.60	0.176	7
		QPSK		37		22.55	0.174	7
		QPSK		74		22.43	0.169	7
		QPSK	75	0	1	21.58	0.139	7
		16-QAM	1	0	1	21.85	0.148	7
		16-QAM		37		21.87	0.149	7
		16-QAM		74		21.83	0.147	7
		16-QAM	75	0	2	20.62	0.111	7



Band	Channel Freq. (MHz)	Modulation	RB No.	RB offset	MPR	Conducted Output Power (dBm)	RF Output Power (W) ERP	Limit (W) ERP
Band 26 15MHz	26865 831.5	64-QAM	1	0	0	21.21	0.128	7
		64-QAM		37		21.27	0.129	7
		64-QAM		74		21.13	0.125	7
		64-QAM	75	0	1	19.90	0.094	7
	26915 836.5	64-QAM	1	0	0	21.23	0.128	7
		64-QAM		37		21.34	0.132	7
		64-QAM		74		21.14	0.126	7
		64-QAM	75	0	1	19.92	0.095	7
	26965 841.5	64-QAM	1	0	0	21.19	0.127	7
		64-QAM		37		21.25	0.129	7
		64-QAM		74		21.13	0.125	7
		64-QAM	75	0	1	19.86	0.094	7

Note:

1. Measure Level (ERP) = Reading Level (dBm) + Antenna Gain(dBi)-2.15dB
2. power (W)=  $(10^{(\text{power(dBm)}/10)}) * 10^{-3}$

Product	Module		
Test Item	RF Output Power		
Test Mode	Mode 4: LTE Band 7		
Date of Test	2020/08/19	Test Site	SR12-H
Temperature(°C)	23	Humidity (%RH)	67

Band	Channel Freq. (MHz)	Modulation	RB No.	RB offset	MPR	Conducted Output Power (dBm)	RF Output Power (W) EIRP	Limit (W) EIRP
Band 7 5MHz	20775 2502.5	QPSK	1	0	0	20.65	0.184	2
		QPSK		12		20.74	0.188	2
		QPSK		24		20.56	0.180	2
		QPSK	25	0	1	19.62	0.145	2
		16-QAM	1	0	1	19.64	0.146	2
		16-QAM		12		19.68	0.147	2
		16-QAM		24		19.59	0.144	2
		16-QAM	25	0	2	18.71	0.118	2
	21100 2535	QPSK	1	0	0	20.72	0.187	2
		QPSK		12		20.80	0.191	2
		QPSK		24		20.67	0.185	2
		QPSK	25	0	1	19.63	0.146	2
		16-QAM	1	0	1	19.88	0.154	2
		16-QAM		12		19.97	0.157	2
		16-QAM		24		19.83	0.152	2
		16-QAM	25	0	2	18.54	0.113	2
	21425 2567.5	QPSK	1	0	0	20.44	0.175	2
		QPSK		12		20.51	0.178	2
		QPSK		24		20.35	0.172	2
		QPSK	25	0	1	19.50	0.141	2
		16-QAM	1	0	1	19.57	0.144	2
		16-QAM		12		19.67	0.147	2
		16-QAM		24		19.52	0.142	2
		16-QAM	25	0	2	18.53	0.113	2

Band	Channel Freq. (MHz)	Modulation	RB No.	RB offset	MPR	Conducted Output Power (dBm)	RF Output Power (W) EIRP	Limit (W) EIRP
Band 7 5MHz	20775 2502.5	64-QAM	1	0	0	19.13	0.130	2
		64-QAM		12		19.05	0.127	2
		64-QAM		24		19.10	0.129	2
		64-QAM	25	0	1	17.85	0.097	2
	21100 2535	64-QAM	1	0	0	19.16	0.131	2
		64-QAM		12		19.02	0.126	2
		64-QAM		24		19.13	0.130	2
		64-QAM	25	0	1	17.91	0.098	2
	21425 2567.5	64-QAM	1	0	0	19.09	0.129	2
		64-QAM		12		19.01	0.126	2
		64-QAM		24		19.15	0.130	2
		64-QAM	25	0	1	17.96	0.099	2

Note:

1. Measure Level (EIRP) = Reading Level (dBm) + Antenna Gain(dBi)
2. power (W)=  $(10^{(\text{power(dBm)}/10)}) * 10^{-3}$

Band	Channel Freq. (MHz)	Modulation	RB No.	RB offset	MPR	Conducted Output Power (dBm)	RF Output Power (W) EIRP	Limit (W) EIRP
Band 7 10MHz	20800 2505	QPSK	1	0	0	20.56	0.180	2
		QPSK		24		20.50	0.178	2
		QPSK		49		20.51	0.178	2
		QPSK	50	0	1	19.66	0.147	2
		16-QAM	1	0	1	19.85	0.153	2
		16-QAM		24		19.80	0.151	2
		16-QAM		49		19.70	0.148	2
		16-QAM		50		0	2	18.70
	21100 2535	QPSK	1	0	0	20.79	0.190	2
		QPSK		24		20.63	0.183	2
		QPSK		49		20.60	0.182	2
		QPSK	50	0	1	19.62	0.145	2
		16-QAM	1	0	1	19.84	0.153	2
		16-QAM		24		19.67	0.147	2
		16-QAM		49		19.63	0.146	2
		16-QAM		50		0	2	18.60
	21400 2565	QPSK	1	0	0	20.43	0.175	2
		QPSK		24		20.44	0.175	2
		QPSK		49		20.36	0.172	2
		QPSK	50	0	1	19.49	0.141	2
		16-QAM	1	0	1	19.50	0.141	2
		16-QAM		24		19.45	0.140	2
		16-QAM		49		19.44	0.139	2
		16-QAM		50		0	2	18.46

Band	Channel Freq. (MHz)	Modulation	RB No.	RB offset	MPR	Conducted Output Power (dBm)	RF Output Power (W) EIRP	Limit (W) EIRP
Band 7 10MHz	20800 2505	64-QAM	1	0	0	19.06	0.128	2
		64-QAM		24		19.01	0.126	2
		64-QAM		49		18.95	0.124	2
		64-QAM	50	0	1	17.82	0.096	2
	21100 2535	64-QAM	1	0	0	19.21	0.132	2
		64-QAM		24		19.09	0.129	2
		64-QAM		49		18.91	0.123	2
		64-QAM	50	0	1	17.81	0.096	2
	21400 2565	64-QAM	1	0	0	19.04	0.127	2
		64-QAM		24		18.98	0.125	2
		64-QAM		49		18.88	0.122	2
		64-QAM	50	0	1	17.77	0.095	2

Note:

1. Measure Level (EIRP) = Reading Level (dBm) + Antenna Gain(dBi)
2. power (W)=  $(10^{(\text{power(dBm)}/10)}) * 10^{-3}$

Band	Channel Freq. (MHz)	Modulation	RB No.	RB offset	MPR	Conducted Output Power (dBm)	RF Output Power (W) EIRP	Limit (W) EIRP
Band 7 15MHz	20825 2507.5	QPSK	1	0	0	20.61	0.182	2
		QPSK		37		20.49	0.177	2
		QPSK		74		20.46	0.176	2
		QPSK	75	0	1	19.62	0.145	2
		16-QAM	1	0	1	19.83	0.152	2
		16-QAM		37		19.77	0.150	2
		16-QAM		74		19.78	0.151	2
		16-QAM	75	0	2	18.60	0.115	2
	21100 2535	QPSK	1	0	0	20.69	0.186	2
		QPSK		37		20.52	0.179	2
		QPSK		74		20.50	0.178	2
		QPSK	75	0	1	19.50	0.141	2
		16-QAM	1	0	1	19.89	0.155	2
		16-QAM		37		19.71	0.148	2
		16-QAM		74		19.69	0.148	2
		16-QAM	75	0	2	18.61	0.115	2
	21375 2562.5	QPSK	1	0	0	20.52	0.179	2
		QPSK		37		20.45	0.176	2
		QPSK		74		20.48	0.177	2
		QPSK	75	0	1	19.46	0.140	2
		16-QAM	1	0	1	19.87	0.154	2
		16-QAM		37		19.80	0.151	2
		16-QAM		74		19.86	0.153	2
		16-QAM	75	0	2	18.48	0.112	2

Band	Channel Freq. (MHz)	Modulation	RB No.	RB offset	MPR	Conducted Output Power (dBm)	RF Output Power (W) EIRP	Limit (W) EIRP
Band 7 15MHz	20825 2507.5	64-QAM	1	0	0	19.19	0.132	2
		64-QAM		37		19.05	0.127	2
		64-QAM		74		19.02	0.126	2
		64-QAM	75	0	1	17.74	0.094	2
	21100 2535	64-QAM	1	0	0	19.22	0.132	2
		64-QAM		37		19.10	0.129	2
		64-QAM		74		19.01	0.126	2
		64-QAM	75	0	1	17.78	0.095	2
	21375 2562.5	64-QAM	1	0	0	19.15	0.130	2
		64-QAM		37		19.00	0.126	2
		64-QAM		74		18.94	0.124	2
		64-QAM	75	0	1	17.71	0.094	2

Note:

1. Measure Level (EIRP) = Reading Level (dBm) + Antenna Gain(dBi)
2. power (W)=  $(10^{(\text{power(dBm)}/10)}) * 10^{-3}$

Band	Channel Freq. (MHz)	Modulation	RB No.	RB offset	MPR	Conducted Output Power (dBm)	RF Output Power (W) EIRP	Limit (W) EIRP
Band 7 20MHz	20850 2510	QPSK	1	0	0	20.78	0.190	2
		QPSK		49		20.70	0.186	2
		QPSK		99		20.67	0.185	2
		QPSK	100	0	1	19.70	0.148	2
		16-QAM	1	0	1	19.89	0.155	2
		16-QAM		49		19.71	0.148	2
		16-QAM		99		19.59	0.144	2
		16-QAM	100	0	2	18.68	0.117	2
	21100 2535	QPSK	1	0	0	20.84	0.192	2
		QPSK		49		20.47	0.177	2
		QPSK		99		20.30	0.170	2
		QPSK	100	0	1	20.30	0.170	2
		16-QAM	1	0	1	19.57	0.144	2
		16-QAM		49		19.71	0.148	2
		16-QAM		99		19.64	0.146	2
		16-QAM	100	0	2	18.68	0.117	2
	21350 2560	QPSK	1	0	0	20.62	0.183	2
		QPSK		49		20.35	0.172	2
		QPSK		99		20.34	0.171	2
		QPSK	100	0	1	19.48	0.141	2
		16-QAM	1	0	1	19.71	0.148	2
		16-QAM		49		19.52	0.142	2
		16-QAM		99		19.48	0.141	2
		16-QAM	100	0	2	18.48	0.112	2



Band	Channel Freq. (MHz)	Modulation	RB No.	RB offset	MPR	Conducted Output Power (dBm)	RF Output Power (W) EIRP	Limit (W) EIRP
Band 7 20MHz	20850 2510	64-QAM	1	0	0	19.24	0.133	2
		64-QAM		49		19.11	0.129	2
		64-QAM		99		19.05	0.127	2
		64-QAM	100	0	1	17.79	0.095	2
	21100 2535	64-QAM	1	0	0	19.32	0.136	2
		64-QAM		49		19.16	0.131	2
		64-QAM		99		19.08	0.128	2
		64-QAM	100	0	1	17.85	0.097	2
	21350 2560	64-QAM	1	0	0	19.19	0.132	2
		64-QAM		49		19.13	0.130	2
		64-QAM		99		19.04	0.127	2
		64-QAM	100	0	1	17.81	0.096	2

Note:

1. Measure Level (EIRP) = Reading Level (dBm) + Antenna Gain(dBi)
2. power (W)=  $(10^{(\text{power(dBm)}/10)}) * 10^{-3}$

Product	Module		
Test Item	RF Output Power		
Test Mode	Mode 5: LTE Band 12		
Date of Test	2020/08/19	Test Site	SR12-H
Temperature(°C)	23	Humidity (%RH)	67

Band	Channel Freq. (MHz)	Modulation	RB No.	RB offset	MPR	Conducted Output Power (dBm)	RF Output Power (W) ERP	Limit (W) ERP
Band 12 1.4MHz	23017 699.7	QPSK	1	0	0	22.64	0.177	3
		QPSK		2		22.73	0.181	3
		QPSK		5		22.66	0.178	3
		QPSK	6	0	1	21.61	0.140	3
		16-QAM	1	0	1	21.73	0.144	3
		16-QAM		2		21.82	0.147	3
		16-QAM		5		21.69	0.143	3
		16-QAM	6	0	2	20.55	0.110	3
	23095 707.5	QPSK	1	0	0	22.83	0.185	3
		QPSK		2		22.91	0.189	3
		QPSK		5		22.82	0.185	3
		QPSK	6	0	1	21.81	0.147	3
		16-QAM	1	0	1	21.76	0.145	3
		16-QAM		2		21.79	0.146	3
		16-QAM		5		21.65	0.141	3
		16-QAM	6	0	2	20.73	0.114	3
	23173 715.3	QPSK	1	0	0	22.98	0.192	3
		QPSK		2		23.08	0.196	3
		QPSK		5		23.04	0.195	3
		QPSK	6	0	1	22.02	0.154	3
		16-QAM	1	0	1	22.11	0.157	3
		16-QAM		2		22.23	0.161	3
		16-QAM		5		22.10	0.157	3
		16-QAM	6	0	2	20.99	0.121	3

Band	Channel Freq. (MHz)	Modulation	RB No.	RB offset	MPR	Conducted Output Power (dBm)	RF Output Power (W) ERP	Limit (W) ERP
Band 12 1.4MHz	23017 699.7	64-QAM	1	0	0	20.94	0.120	3
		64-QAM		2		21.13	0.125	3
		64-QAM		5		20.88	0.118	3
		64-QAM	6	0	1	19.84	0.093	3
	23097 707.5	64-QAM	1	0	0	20.95	0.120	3
		64-QAM		2		21.17	0.126	3
		64-QAM		5		20.85	0.117	3
		64-QAM	6	0	1	19.82	0.093	3
	23173 715.3	64-QAM	1	0	0	20.91	0.119	3
		64-QAM		2		21.08	0.124	3
		64-QAM		5		20.82	0.117	3
		64-QAM	6	0	1	19.79	0.092	3

Note:

1. Measure Level (ERP) = Reading Level (dBm) + Antenna Gain(dBi)-2.15dB
2. power (W)=  $(10^{(\text{power(dBm)}/10)}) * 10^{-3}$

Band	Channel Freq. (MHz)	Modulation	RB No.	RB offset	MPR	Conducted Output Power (dBm)	RF Output Power (W) ERP	Limit (W) ERP		
Band 12 3MHz	23025 700.5	QPSK	1	0	0	22.53	0.173	3		
		QPSK		7		22.57			0.175	3
		QPSK		14		22.62			0.177	3
		QPSK	15	0	1	21.64	0.141	3		
		16-QAM	1	0	1	21.79	0.146	3		
		16-QAM		7		21.81			0.147	3
		16-QAM		14		21.88			0.149	3
		16-QAM	15	0	2	20.72	0.114	3		
	23095 707.5	QPSK	1	0	0	22.78	0.183	3		
		QPSK		7		22.84			0.186	3
		QPSK		14		22.73			0.181	3
		QPSK	15	0	1	21.83	0.147	3		
		16-QAM	1	0	1	21.79	0.146	3		
		16-QAM		7		21.90			0.150	3
		16-QAM		14		21.84			0.148	3
		16-QAM	15	0	2	20.74	0.115	3		
	23165 714.5	QPSK	1	0	0	22.94	0.190	3		
		QPSK		7		23.10			0.197	3
		QPSK		14		23.06			0.195	3
		QPSK	15	0	1	22.06	0.155	3		
		16-QAM	1	0	1	21.96	0.152	3		
		16-QAM		7		22.14			0.158	3
		16-QAM		14		22.04			0.155	3
		16-QAM	15	0	2	21.01	0.122	3		

Band	Channel Freq. (MHz)	Modulation	RB No.	RB offset	MPR	Conducted Output Power (dBm)	RF Output Power (W) ERP	Limit (W) ERP
Band 12 3MHz	23025 700.5	64-QAM	1	0	0	20.85	0.117	3
		64-QAM		7		21.18	0.127	3
		64-QAM		14		20.83	0.117	3
		64-QAM	15	0	1	19.76	0.091	3
	23095 707.5	64-QAM	1	0	0	20.90	0.119	3
		64-QAM		7		21.22	0.128	3
		64-QAM		14		20.88	0.118	3
		64-QAM	15	0	1	19.81	0.092	3
	23165 714.5	64-QAM	1	0	0	20.86	0.118	3
		64-QAM		7		21.15	0.126	3
		64-QAM		14		20.85	0.117	3
		64-QAM	15	0	1	19.78	0.092	3

Note:

1. Measure Level (ERP) = Reading Level (dBm) + Antenna Gain(dBi)-2.15dB
2. power (W)=  $(10^{(\text{power(dBm)}/10)}) * 10^{-3}$

Band	Channel Freq. (MHz)	Modulation	RB No.	RB offset	MPR	Conducted Output Power (dBm)	RF Output Power (W) ERP	Limit (W) ERP
Band 12 5MHz	23035 701.5	QPSK	1	0	0	22.75	0.182	3
		QPSK		12		22.47	0.171	3
		QPSK		24		22.76	0.182	3
		QPSK	25	0	1	21.75	0.145	3
		16-QAM	1	0	1	21.85	0.148	3
		16-QAM		12		22.06	0.155	3
		16-QAM		24		21.94	0.151	3
		16-QAM	25	0	2	20.72	0.114	3
	23095 707.5	QPSK	1	0	0	22.91	0.189	3
		QPSK		12		22.80	0.184	3
		QPSK		24		22.93	0.190	3
		QPSK	25	0	1	21.91	0.150	3
		16-QAM	1	0	1	21.77	0.145	3
		16-QAM		12		21.97	0.152	3
		16-QAM		24		21.74	0.144	3
		16-QAM	25	0	2	20.91	0.119	3
	23155 713.5	QPSK	1	0	0	23.00	0.193	3
		QPSK		12		22.78	0.183	3
		QPSK		24		23.20	0.202	3
		QPSK	25	0	1	22.08	0.156	3
		16-QAM	1	0	1	22.32	0.165	3
		16-QAM		12		22.45	0.170	3
		16-QAM		24		22.41	0.168	3
		16-QAM	25	0	2	20.99	0.121	3

Band	Channel Freq. (MHz)	Modulation	RB No.	RB offset	MPR	Conducted Output Power (dBm)	RF Output Power (W) ERP	Limit (W) ERP
Band 12 5MHz	23035 701.5	64-QAM	1	0	0	20.86	0.118	3
		64-QAM		12		21.01	0.122	3
		64-QAM		24		20.89	0.119	3
		64-QAM	25	0	1	19.75	0.091	3
	23095 707.5	64-QAM	1	0	0	20.93	0.120	3
		64-QAM		12		21.13	0.125	3
		64-QAM		24		20.88	0.118	3
		64-QAM	25	0	1	19.77	0.092	3
	23155 713.5	64-QAM	1	0	0	20.89	0.119	3
		64-QAM		12		21.04	0.123	3
		64-QAM		24		20.90	0.119	3
		64-QAM	25	0	1	19.71	0.090	3

Note:

1. Measure Level (ERP) = Reading Level (dBm) + Antenna Gain(dBi)-2.15dB
2. power (W)=  $(10^{(\text{power(dBm)}/10)}) * 10^{-3}$

Band	Channel Freq. (MHz)	Modulation	RB No.	RB offset	MPR	Conducted Output Power (dBm)	RF Output Power (W) ERP	Limit (W) ERP			
Band 12 10MHz	23060 704	QPSK	1	0	0	22.92	0.189	3			
		QPSK		24		22.61			0.176	3	
		QPSK		49		22.63			0.177	3	
		QPSK	50	0	1	21.73	0.144	3			
		16-QAM		0		21.74			0.144	3	
		16-QAM		1		24			21.96	0.152	3
		16-QAM				49			21.90	0.150	3
		16-QAM	50	0	2	20.76	0.115	3			
	23095 707.5	QPSK	1	0	0	23.28	0.206	3			
		QPSK		24		22.90			0.188	3	
		QPSK		49		22.88			0.187	3	
		QPSK	50	0	1	21.97	0.152	3			
		16-QAM		0		21.93			0.151	3	
		16-QAM		1		24			22.02	0.154	3
		16-QAM				49			22.01	0.153	3
		16-QAM	50	0	2	20.98	0.121	3			
	23130 711	QPSK	1	0	0	23.02	0.194	3			
		QPSK		24		22.95			0.191	3	
		QPSK		49		23.04			0.195	3	
		QPSK	50	0	1	22.02	0.154	3			
		16-QAM		0		21.93			0.151	3	
		16-QAM		1		24			22.03	0.154	3
		16-QAM				49			22.15	0.158	3
		16-QAM	50	0	2	21.03	0.122	3			



Band	Channel Freq. (MHz)	Modulation	RB No.	RB offset	MPR	Conducted Output Power (dBm)	RF Output Power (W) ERP	Limit (W) ERP
Band 12 10MHz	23060 704	64-QAM	1	0	0	21.19	0.127	3
		64-QAM		24		20.94	0.120	3
		64-QAM		49		20.90	0.119	3
		64-QAM	50	0	1	19.80	0.092	3
	23095 707.5	64-QAM	1	0	0	21.22	0.128	3
		64-QAM		24		20.97	0.121	3
		64-QAM		49		21.01	0.122	3
		64-QAM	50	0	1	19.84	0.093	3
	23130 711	64-QAM	1	0	0	21.14	0.126	3
		64-QAM		24		20.93	0.120	3
		64-QAM		49		20.99	0.121	3
		64-QAM	50	0	1	19.83	0.093	3

Note:

1. Measure Level (ERP) = Reading Level (dBm) + Antenna Gain(dBi)-2.15dB
2. power (W)=  $(10^{(\text{power(dBm)}/10)}) * 10^{-3}$

Product	Module		
Test Item	RF Output Power		
Test Mode	Mode 6: LTE Band 13		
Date of Test	2020/08/19	Test Site	SR12-H
Temperature(°C)	23	Humidity (%RH)	67

Band	Channel Freq. (MHz)	Modulation	RB No.	RB offset	MPR	Conducted Output Power (dBm)	RF Output Power (W) ERP	Limit (W) ERP
Band 13 5MHz	23205 779.5	QPSK	1	0	0	23.19	0.201	3
		QPSK		12		22.99	0.192	3
		QPSK		24		23.14	0.199	3
		QPSK	25	0	1	22.08	0.156	3
		16-QAM	1	0	1	22.42	0.169	3
		16-QAM		12		22.52	0.173	3
		16-QAM		24		22.40	0.168	3
		16-QAM	25	0	2	21.03	0.122	3
	23230 782	QPSK	1	0	0	23.21	0.202	3
		QPSK		12		23.22	0.203	3
		QPSK		24		23.13	0.199	3
		QPSK	25	0	1	22.05	0.155	3
		16-QAM	1	0	1	22.32	0.165	3
		16-QAM		12		22.26	0.163	3
		16-QAM		24		22.27	0.163	3
		16-QAM	25	0	2	21.06	0.123	3
	23255 784.5	QPSK	1	0	0	23.25	0.204	3
		QPSK		12		23.18	0.201	3
		QPSK		24		23.15	0.200	3
		QPSK	25	0	1	22.04	0.155	3
		16-QAM	1	0	1	22.01	0.153	3
		16-QAM		12		22.06	0.155	3
		16-QAM		24		22.01	0.153	3
		16-QAM	25	0	2	21.10	0.124	3

Band	Channel Freq. (MHz)	Modulation	RB No.	RB offset	MPR	Conducted Output Power (dBm)	RF Output Power (W) ERP	Limit (W) ERP
Band 13 5MHz	23205 779.5	64-QAM	1	0	0	21.31	0.131	3
		64-QAM		12		21.15	0.126	3
		64-QAM		24		21.24	0.129	3
		64-QAM	25	0	1	19.90	0.094	3
	23230 782	64-QAM	1	0	0	21.33	0.131	3
		64-QAM		12		21.18	0.127	3
		64-QAM		24		21.25	0.129	3
		64-QAM	25	0	1	19.94	0.095	3
	23255 784.5	64-QAM	1	0	0	21.28	0.130	3
		64-QAM		12		21.17	0.126	3
		64-QAM		24		21.21	0.128	3
		64-QAM	25	0	1	19.91	0.095	3

Note:

1. Measure Level (ERP) = Reading Level (dBm) + Antenna Gain(dBi)-2.15dB
2. power (W)=  $(10^{(\text{power(dBm)}/10)}) * 10^{-3}$

Band	Channel Freq. (MHz)	Modulation	RB No.	RB offset	MPR	Conducted Output Power (dBm)	RF Output Power (W) ERP	Limit (W) ERP		
Band 13 10MHz	23230 782	QPSK	1	0	0	23.31	0.207	3		
		QPSK		24		22.94	0.190	3		
		QPSK		49		22.85	0.186	3		
		QPSK	50	0	1	22.05	0.155	3		
		16-QAM	1	0	1	22.27	0.163	3		
		16-QAM		24		22.18	0.160	3		
		16-QAM		49		22.16	0.159	3		
		16-QAM	50	0	2	21.07	0.124	3		
		Band 13 10MHz	23230 782	64-QAM	1	0	0	21.31	0.131	3
				64-QAM		24		21.22	0.128	3
64-QAM	49			21.28		0.130		3		
64-QAM	50			0	1	19.98	0.096	3		

Note:

1. Measure Level (ERP) = Reading Level (dBm) + Antenna Gain(dBi)-2.15dB
2. power (W)=  $(10^{(\text{power(dBm)}/10)}) * 10^{-3}$

Product	Module		
Test Item	RF Output Power		
Test Mode	Mode 7: LTE Band 14		
Date of Test	2020/08/19	Test Site	SR12-H
Temperature(°C)	23	Humidity (%RH)	67

Band	Channel Freq. (MHz)	Modulation	RB No.	RB offset	MPR	Conducted Output Power (dBm)	RF Output Power (W) ERP	Limit (W) ERP
Band 14 5MHz	23305 790.5	QPSK	1	0	0	23.28	0.206	3
		QPSK		12		23.26	0.205	3
		QPSK		24		23.03	0.194	3
		QPSK	25	0	1	22.17	0.159	3
		16-QAM	1	0	1	22.48	0.171	3
		16-QAM		12		22.54	0.173	3
		16-QAM		24		22.39	0.167	3
		16-QAM	25	0	2	21.05	0.123	3
	23330 793	QPSK	1	0	0	23.22	0.203	3
		QPSK		12		23.27	0.205	3
		QPSK		24		23.17	0.200	3
		QPSK	25	0	1	22.10	0.157	3
		16-QAM	1	0	1	22.27	0.163	3
		16-QAM		12		22.33	0.165	3
		16-QAM		24		22.24	0.162	3
		16-QAM	25	0	2	21.12	0.125	3
	23355 795.5	QPSK	1	0	0	23.32	0.207	3
		QPSK		12		23.26	0.205	3
		QPSK		24		23.16	0.200	3
		QPSK	25	0	1	22.05	0.155	3
		16-QAM	1	0	1	22.11	0.157	3
		16-QAM		12		22.08	0.156	3
		16-QAM		24		22.01	0.153	3
		16-QAM	25	0	2	21.14	0.126	3

Band	Channel Freq. (MHz)	Modulation	RB No.	RB offset	MPR	Conducted Output Power (dBm)	RF Output Power (W) ERP	Limit (W) ERP
Band 14 5MHz	23305 790.5	64-QAM	1	0	0	21.58	0.139	3
		64-QAM		12		21.25	0.129	3
		64-QAM		24		21.13	0.125	3
		64-QAM	25	0	1	19.96	0.096	3
	23330 793	64-QAM	1	0	0	21.57	0.139	3
		64-QAM		12		21.28	0.130	3
		64-QAM		24		21.17	0.126	3
		64-QAM	25	0	1	19.94	0.095	3
	23355 795.5	64-QAM	1	0	0	21.55	0.138	3
		64-QAM		12		21.23	0.128	3
		64-QAM		24		21.14	0.126	3
		64-QAM	25	0	1	19.91	0.095	3

Note:

1. Measure Level (ERP) = Reading Level (dBm) + Antenna Gain(dBi)-2.15dB
2. power (W)=  $(10^{(\text{power(dBm)}/10)}) * 10^{-3}$

Band	Channel Freq. (MHz)	Modulation	RB No.	RB offset	MPR	Conducted Output Power (dBm)	RF Output Power (W) ERP	Limit (W) ERP			
Band 14 10MHz	23330 793	QPSK	1	0	0	23.38	0.210	3			
		QPSK		24		22.99	0.192	3			
		QPSK		49		22.93	0.190	3			
		QPSK	16-QAM	50	0	1	22.12	0.157	3		
		16-QAM		1	0	1	22.28	0.163	3		
		16-QAM			24		22.17	0.159	3		
		16-QAM			49		22.14	0.158	3		
		16-QAM		50	0	2	21.12	0.125	3		
		Band 14 10MHz		23330 793	64-QAM	1	0	0	21.51	0.137	3
					64-QAM		24		21.39	0.133	3
64-QAM	49		21.32		0.131		3				
64-QAM	50		0		1	19.96	0.096	3			

Note:

1. Measure Level (ERP) = Reading Level (dBm) + Antenna Gain(dBi)-2.15dB
2. power (W)=  $(10^{(\text{power(dBm)}/10)}) * 10^{-3}$

Product	Module		
Test Item	RF Output Power		
Test Mode	Mode 8: LTE Band 26 (Part 90)		
Date of Test	2020/08/19	Test Site	SR12-H
Temperature(°C)	23	Humidity (%RH)	67

Band	Channel Freq. (MHz)	Modulation	RB No.	RB offset	MPR	Conducted Output Power (dBm)	RF Output Power (W) ERP	Limit (W) ERP
Band 26 1.4MHz	26697 814.7	QPSK	1	0	0	22.50	0.172	100
		QPSK		2		22.33	0.165	100
		QPSK		5		22.42	0.169	100
		QPSK	6	0	1	21.47	0.136	100
		16-QAM	1	0	1	21.33	0.131	100
		16-QAM		2		21.40	0.133	100
		16-QAM		5		21.33	0.131	100
		16-QAM		6		0	2	20.49
	26740 819	QPSK	1	0	0	22.30	0.164	100
		QPSK		2		22.44	0.169	100
		QPSK		5		22.45	0.170	100
		QPSK	6	0	1	21.38	0.133	100
		16-QAM	1	0	1	21.32	0.131	100
		16-QAM		2		21.50	0.136	100
		16-QAM		5		21.43	0.134	100
		16-QAM		6		0	2	20.30
	26783 823.3	QPSK	1	0	0	22.24	0.162	100
		QPSK		2		22.33	0.165	100
		QPSK		5		22.28	0.163	100
		QPSK	6	0	1	21.32	0.131	100
		16-QAM	1	0	1	21.07	0.124	100
		16-QAM		2		21.12	0.125	100
		16-QAM		5		21.05	0.123	100
		16-QAM		6		0	2	20.34



Band	Channel Freq. (MHz)	Modulation	RB No.	RB offset	MPR	Conducted Output Power (dBm)	RF Output Power (W) ERP	Limit (W) ERP	
Band 26 1.4MHz	26697 814.7	64-QAM	1	0	0	21.02	0.122	100	
		64-QAM		2		20.98	0.121	100	
		64-QAM		5		20.94	0.120	100	
			64-QAM	6	0	1	19.77	0.092	100
	26740 819	64-QAM	1	0	0	21.05	0.123	100	
		64-QAM		2		21.01	0.122	100	
		64-QAM		5		20.95	0.120	100	
		64-QAM	6	0	1	19.75	0.091	100	
	26783 823.3	64-QAM	1	0	0	21.03	0.122	100	
		64-QAM		2		20.95	0.120	100	
		64-QAM		5		20.98	0.121	100	
		64-QAM	6	0	1	19.79	0.092	100	

Note:

1. Measure Level (ERP) = Reading Level (dBm) + Antenna Gain(dBi)-2.15dB
2. power (W)=  $(10^{(\text{power(dBm)}/10)}) * 10^{-3}$

Band	Channel Freq. (MHz)	Modulation	RB No.	RB offset	MPR	Conducted Output Power (dBm)	RF Output Power (W) ERP	Limit (W) ERP
Band 26 3MHz	26705 815.5	QPSK	1	0	0	22.42	0.169	100
		QPSK		7		22.41	0.168	100
		QPSK		14		22.38	0.167	100
		QPSK	15	0	1	21.58	0.139	100
		16-QAM		1	0	22.07	0.156	100
		16-QAM			7	22.06	0.155	100
		16-QAM			14	22.01	0.153	100
		16-QAM	15	0	2	20.66	0.112	100
	26740 819	QPSK	1	0	0	22.45	0.170	100
		QPSK		7		22.51	0.172	100
		QPSK		14		22.48	0.171	100
		QPSK	15	0	1	21.50	0.136	100
		16-QAM		1	0	21.28	0.130	100
		16-QAM			7	21.37	0.132	100
		16-QAM			14	21.29	0.130	100
		16-QAM	15	0	2	20.49	0.108	100
	26775 822.5	QPSK	1	0	0	22.38	0.167	100
		QPSK		7		22.46	0.170	100
		QPSK		14		22.41	0.168	100
		QPSK	15	0	1	21.47	0.136	100
		16-QAM		1	0	21.49	0.136	100
		16-QAM			7	21.47	0.136	100
		16-QAM			14	21.41	0.134	100
		16-QAM	15	0	2	20.48	0.108	100

Band	Channel Freq. (MHz)	Modulation	RB No.	RB offset	MPR	Conducted Output Power (dBm)	RF Output Power (W) ERP	Limit (W) ERP
Band 26 3MHz	26705 815.5	64-QAM	1	0	0	21.06	0.123	100
		64-QAM		7		21.17	0.126	100
		64-QAM		14		21.11	0.125	100
		64-QAM	15	0	1	19.79	0.092	100
	26740 819	64-QAM	1	0	0	21.10	0.124	100
		64-QAM		7		21.18	0.127	100
		64-QAM		14		21.13	0.125	100
		64-QAM	15	0	1	19.85	0.093	100
	26775 822.5	64-QAM	1	0	0	21.08	0.124	100
		64-QAM		7		21.15	0.126	100
		64-QAM		14		21.10	0.124	100
		64-QAM	15	0	1	19.82	0.093	100

Note:

1. Measure Level (ERP) = Reading Level (dBm) + Antenna Gain(dBi)-2.15dB
2. power (W)=  $(10^{(\text{power(dBm)}/10)}) * 10^{-3}$

Band	Channel Freq. (MHz)	Modulation	RB No.	RB offset	MPR	Conducted Output Power (dBm)	RF Output Power (W) ERP	Limit (W) ERP
Band 26 5MHz	26715 816.5	QPSK	1	0	0	22.51	0.172	100
		QPSK		12		22.46	0.170	100
		QPSK		24		22.35	0.166	100
		QPSK	25	0	1	21.44	0.135	100
		16-QAM	1	0	1	21.45	0.135	100
		16-QAM		12		21.49	0.136	100
		16-QAM		24		21.37	0.132	100
		16-QAM	25	0	2	20.52	0.109	100
	26740 819	QPSK	1	0	0	22.39	0.167	100
		QPSK		12		22.54	0.173	100
		QPSK		24		22.43	0.169	100
		QPSK	25	0	1	21.52	0.137	100
		16-QAM	1	0	1	21.84	0.148	100
		16-QAM		12		22.01	0.153	100
		16-QAM		24		21.83	0.147	100
		16-QAM	25	0	2	20.53	0.109	100
	26765 821.5	QPSK	1	0	0	22.49	0.171	100
		QPSK		12		22.43	0.169	100
		QPSK		24		22.36	0.166	100
		QPSK	25	0	1	21.50	0.136	100
		16-QAM	1	0	1	21.58	0.139	100
		16-QAM		12		21.55	0.138	100
		16-QAM		24		21.51	0.137	100
		16-QAM	25	0	2	20.51	0.109	100

Band	Channel Freq. (MHz)	Modulation	RB No.	RB offset	MPR	Conducted Output Power (dBm)	RF Output Power (W) ERP	Limit (W) ERP	
Band 26 5MHz	26715 816.5	64-QAM	1	0	0	21.21	0.128	100	
		64-QAM		12		21.16	0.126	100	
		64-QAM		24		21.17	0.126	100	
			64-QAM	25	0	1	19.89	0.094	100
	26740 819	64-QAM	1	0	0	21.23	0.128	100	
		64-QAM		12		21.12	0.125	100	
		64-QAM		24		21.18	0.127	100	
		64-QAM	25	0	1	19.86	0.094	100	
	26765 821.5	64-QAM	1	0	0	21.18	0.127	100	
		64-QAM		12		21.08	0.124	100	
		64-QAM		24		21.11	0.125	100	
		64-QAM	25	0	1	19.83	0.093	100	

Note:

1. Measure Level (ERP) = Reading Level (dBm) + Antenna Gain(dBi)-2.15dB
2. power (W)=  $(10^{(\text{power(dBm)}/10)}) * 10^{-3}$

Band	Channel Freq. (MHz)	Modulation	RB No.	RB offset	MPR	Conducted Output Power (dBm)	RF Output Power (W) ERP	Limit (W) ERP
Band 26 10MHz	26740 819	QPSK	1	0	0	22.61	0.176	100
		QPSK		24		22.39	0.167	100
		QPSK		49		22.27	0.163	100
		QPSK	50	0	1	21.46	0.135	100
	26740 819	16-QAM	1	0	1	22.01	0.153	100
		16-QAM		24		21.98	0.152	100
		16-QAM		49		21.87	0.149	100
		16-QAM	50	0	2	20.49	0.108	100
Band 26 10MHz	26740 819	64-QAM	1	0	0	21.18	0.127	100
		64-QAM		24		21.14	0.126	100
		64-QAM		49		21.06	0.123	100
		64-QAM	50	0	1	19.76	0.091	100

Note:

1. Measure Level (ERP) = Reading Level (dBm) + Antenna Gain(dBi)-2.15dB
2. power (W)=  $(10^{(\text{power(dBm)}/10)}) * 10^{-3}$

Product	Module		
Test Item	RF Output Power		
Test Mode	Mode 9: LTE Band 41 (FCC)		
Date of Test	2020/08/19	Test Site	SR12-H
Temperature(°C)	23	Humidity (%RH)	67

Band	Channel Freq. (MHz)	Modulation	RB No.	RB offset	MPR	Conducted Output Power (dBm)	RF Output Power (W) EIRP	Limit (W) EIRP
Band 41 5MHz	39675 2498.5	QPSK	1	0	0	21.32	0.215	2
		QPSK		12		21.38	0.218	2
		QPSK		24		21.28	0.213	2
		QPSK	25	0	1	20.39	0.173	2
		16-QAM	1	0	1	20.50	0.178	2
		16-QAM		12		20.62	0.183	2
		16-QAM		24		20.45	0.176	2
		16-QAM	25	0	2	19.42	0.139	2
	40620 2593	QPSK	1	0	0	21.37	0.217	2
		QPSK		12		21.38	0.218	2
		QPSK		24		21.30	0.214	2
		QPSK	25	0	1	20.29	0.169	2
		16-QAM	1	0	1	20.21	0.166	2
		16-QAM		12		20.30	0.170	2
		16-QAM		24		20.15	0.164	2
		16-QAM	25	0	2	19.38	0.137	2
	41565 2687.5	QPSK	1	0	0	21.59	0.229	2
		QPSK		12		21.67	0.233	2
		QPSK		24		21.55	0.226	2
		QPSK	25	0	1	20.46	0.176	2
		16-QAM	1	0	1	20.76	0.189	2
		16-QAM		12		20.88	0.194	2
		16-QAM		24		20.75	0.188	2
		16-QAM	25	0	2	19.39	0.138	2

Band	Channel Freq. (MHz)	Modulation	RB No.	RB offset	MPR	Conducted Output Power (dBm)	RF Output Power (W) EIRP	Limit (W) EIRP
Band 41 5MHz	39675 2498.5	64-QAM	1	0	0	20.45	0.176	2
		64-QAM		12		20.41	0.174	2
		64-QAM		24		20.22	0.167	2
		64-QAM	25	0	1	19.41	0.138	2
	40620 2593	64-QAM	1	0	0	20.44	0.175	2
		64-QAM		12		20.35	0.172	2
		64-QAM		24		20.38	0.173	2
		64-QAM	25	0	1	19.48	0.141	2
	41565 2687.5	64-QAM	1	0	0	20.39	0.173	2
		64-QAM		12		20.38	0.173	2
		64-QAM		24		20.31	0.170	2
		64-QAM	25	0	1	19.40	0.138	2

Note:

1. Measure Level (EIRP) = Reading Level (dBm) + Antenna Gain(dBi)
2. power (W)=  $(10^{(\text{power(dBm)}/10)}) * 10^{-3}$



Band	Channel Freq. (MHz)	Modulation	RB No.	RB offset	MPR	Conducted Output Power (dBm)	RF Output Power (W) EIRP	Limit (W) EIRP			
Band 41 10MHz	39700 2501	QPSK	1	0	0	21.31	0.214	2			
		QPSK		24		21.21			0.209	2	
		QPSK		49		21.20			0.209	2	
		QPSK	50	0	1	20.43	0.175	2			
		16-QAM		0		20.56			0.180	2	
		16-QAM		1		24			20.55	0.180	2
		16-QAM				49			20.49	0.177	2
		16-QAM	50	0	2	19.39	0.138	2			
	40620 2593	QPSK	1	0	0	21.33	0.215	2			
		QPSK		24		21.31			0.214	2	
		QPSK		49		21.30			0.214	2	
		QPSK	50	0	1	20.29	0.169	2			
		16-QAM		0		20.45			0.176	2	
		16-QAM		1		24			20.37	0.173	2
		16-QAM				49			20.39	0.173	2
		16-QAM	50	0	2	19.34	0.136	2			
	41540 2685	QPSK	1	0	0	21.64	0.231	2			
		QPSK		24		21.66			0.232	2	
		QPSK		49		21.59			0.229	2	
		QPSK	50	0	1	20.54	0.179	2			
		16-QAM		0		20.57			0.181	2	
		16-QAM		1		24			20.60	0.182	2
		16-QAM				49			20.54	0.179	2
		16-QAM	50	0	2	19.55	0.143	2			

Band	Channel Freq. (MHz)	Modulation	RB No.	RB offset	MPR	Conducted Output Power (dBm)	RF Output Power (W) EIRP	Limit (W) EIRP
Band 41 10MHz	39700 2501	64-QAM	1	0	0	20.56	0.180	2
		64-QAM		24		20.48	0.177	2
		64-QAM		49		20.43	0.175	2
		64-QAM	50	0	1	19.41	0.138	2
	40620 2593	64-QAM	1	0	0	20.54	0.179	2
		64-QAM		24		20.44	0.175	2
		64-QAM		49		20.43	0.175	2
		64-QAM	50	0	1	19.35	0.136	2
	41540 2685	64-QAM	1	0	0	20.49	0.177	2
		64-QAM		24		20.42	0.175	2
		64-QAM		49		20.40	0.174	2
		64-QAM	50	0	1	19.34	0.136	2

Note:

1. Measure Level (EIRP) = Reading Level (dBm) + Antenna Gain(dBi)
2. power (W)=  $(10^{(\text{power(dBm)}/10)}) * 10^{-3}$

Band	Channel Freq. (MHz)	Modulation	RB No.	RB offset	MPR	Conducted Output Power (dBm)	RF Output Power (W) EIRP	Limit (W) EIRP						
Band 41 15MHz	39725 2503.5	QPSK	1	0	0	21.36	0.217	2						
		QPSK		37		21.27			0.212	2				
		QPSK		74		21.19			0.208	2				
		QPSK	75	1	0	1	20.35	0.172	2					
		16-QAM			0		20.65			0.184	2			
		16-QAM			37		20.52			0.179	2			
		16-QAM			74		20.47			0.177	2			
		16-QAM	75	2	0	2	19.42	0.139	2					
	QPSK	1			0		0			21.37	0.217	2		
	QPSK				37					21.31			0.214	2
	QPSK				74					21.30			0.214	2
	QPSK	75	1	0	1	20.25	0.168	2						
	16-QAM			1		0			1	20.51	0.178	2		
	16-QAM					37				20.41			0.174	2
	16-QAM					74				20.40			0.174	2
	16-QAM	75	2	0	2	19.31	0.135	2						
	QPSK			1		0			0	21.63	0.231	2		
	QPSK					37				21.58			0.228	2
	QPSK					74				21.53			0.225	2
	QPSK	75	1	0	1	20.46	0.176	2						
	16-QAM			1		0			1	20.83	0.192	2		
	16-QAM					37				20.73			0.187	2
	16-QAM					74				20.67			0.185	2
	16-QAM	75	2	0	2	19.50	0.141	2						

Band	Channel Freq. (MHz)	Modulation	RB No.	RB offset	MPR	Conducted Output Power (dBm)	RF Output Power (W) EIRP	Limit (W) EIRP
Band 41 15MHz	39725 2503.5	64-QAM	1	0	0	20.50	0.178	2
		64-QAM		37		20.40	0.174	2
		64-QAM		74		20.35	0.172	2
		64-QAM	75	0	1	19.38	0.137	2
	40620 2593	64-QAM	1	0	0	20.47	0.177	2
		64-QAM		37		20.38	0.173	2
		64-QAM		74		20.29	0.169	2
		64-QAM	75	0	1	19.31	0.135	2
	41515 2682.5	64-QAM	1	0	0	20.45	0.176	2
		64-QAM		37		20.32	0.171	2
		64-QAM		74		20.28	0.169	2
		64-QAM	75	0	1	19.27	0.134	2

Note:

1. Measure Level (EIRP) = Reading Level (dBm) + Antenna Gain(dBi)
2. power (W)=  $(10^{(\text{power(dBm)}/10)}) * 10^{-3}$

Band	Channel Freq. (MHz)	Modulation	RB No.	RB offset	MPR	Conducted Output Power (dBm)	RF Output Power (W) EIRP	Limit (W) EIRP
Band 41 20MHz	39750 2506	QPSK	1	0	0	21.52	0.225	2
		QPSK		49		21.36	0.217	2
		QPSK		99		21.35	0.216	2
		QPSK	100	0	1	20.46	0.176	2
		16-QAM	1	0	1	20.47	0.177	2
		16-QAM		49		20.38	0.173	2
		16-QAM		99		20.31	0.170	2
		16-QAM	100	0	2	19.40	0.138	2
	40620 2593	QPSK	1	0	0	21.69	0.234	2
		QPSK		49		21.41	0.219	2
		QPSK		99		21.34	0.216	2
		QPSK	100	0	1	20.40	0.174	2
		16-QAM	1	0	1	20.68	0.185	2
		16-QAM		49		20.50	0.178	2
		16-QAM		99		20.41	0.174	2
		16-QAM	100	0	2	19.40	0.138	2
	41490 2680	QPSK	1	0	0	21.58	0.228	2
		QPSK		49		21.57	0.228	2
		QPSK		99		21.56	0.227	2
		QPSK	100	0	1	20.52	0.179	2
		16-QAM	1	0	1	20.79	0.190	2
		16-QAM		49		20.67	0.185	2
		16-QAM		99		20.66	0.185	2
		16-QAM	100	0	2	19.53	0.142	2

Band	Channel Freq. (MHz)	Modulation	RB No.	RB offset	MPR	Conducted Output Power (dBm)	RF Output Power (W) EIRP	Limit (W) EIRP
Band 41 20MHz	39750 2506	64-QAM	1	0	0	20.60	0.182	2
		64-QAM		49		20.41	0.174	2
		64-QAM		99		20.43	0.175	2
		64-QAM	100	0	1	19.34	0.136	2
	40620 2593	64-QAM	1	0	0	20.65	0.184	2
		64-QAM		49		20.40	0.174	2
		64-QAM		99		20.32	0.171	2
		64-QAM	100	0	1	19.41	0.138	2
	41490 2680	64-QAM	1	0	0	20.58	0.181	2
		64-QAM		49		20.37	0.173	2
		64-QAM		99		20.35	0.172	2
		64-QAM	100	0	1	19.37	0.137	2

Note:

1. Measure Level (EIRP) = Reading Level (dBm) + Antenna Gain(dBi)
2. power (W)=  $(10^{(\text{power(dBm)}/10)}) * 10^{-3}$

Product	Module		
Test Item	RF Output Power		
Test Mode	Mode 9: LTE Band 41 (ISED)		
Date of Test	2020/08/19	Test Site	SR12-H
Temperature(°C)	23	Humidity (%RH)	67

Band	Channel Freq. (MHz)	Modulation	RB No.	RB offset	MPR	Conducted Output Power (dBm)	RF Output Power (W) EIRP	Limit (W) EIRP
Band 41 5MHz	39715 2502.5	QPSK	1	0	0	21.31	0.214	2
		QPSK		12		21.36	0.217	2
		QPSK		24		21.25	0.211	2
		QPSK	25	0	1	20.37	0.173	2
		16-QAM	1	0	1	20.52	0.179	2
		16-QAM		12		20.61	0.182	2
		16-QAM		24		20.46	0.176	2
		16-QAM	25	0	2	19.41	0.138	2
Band 41 5MHz	39675 2498.5	64-QAM	1	0	0	20.44	0.175	2
		64-QAM		12		20.43	0.175	2
		64-QAM		24		20.23	0.167	2
		64-QAM	25	0	1	19.42	0.139	2

Note:

1. Measure Level (EIRP) = Reading Level (dBm) + Antenna Gain(dBi)

2. power (W)=  $(10^{(\text{power(dBm)}/10)}) * 10^{-3}$

Band	Channel Freq. (MHz)	Modulation	RB No.	RB offset	MPR	Conducted Output Power (dBm)	RF Output Power (W) EIRP	Limit (W) EIRP	
Band 41 10MHz	39740 2505	QPSK	1	0	0	21.35	0.216	2	
		QPSK		24		21.27	0.212	2	
		QPSK		49		21.25	0.211	2	
		QPSK	50	0	1	20.41	0.174	2	
	16-QAM	1	16-QAM	1	0	1	20.57	0.181	2
			16-QAM		24		20.54	0.179	2
			16-QAM		49		20.42	0.175	2
			16-QAM	50	0	2	19.34	0.136	2
Band 41 10MHz	39700 2501	64-QAM	1	0	0	20.55	0.180	2	
		64-QAM		24		20.47	0.177	2	
		64-QAM		49		20.41	0.174	2	
		64-QAM	50	0	1	19.45	0.140	2	

Note:

1. Measure Level (EIRP) = Reading Level (dBm) + Antenna Gain(dBi)
2. power (W)=  $(10^{(\text{power(dBm)}/10)}) * 10^{-3}$



Band	Channel Freq. (MHz)	Modulation	RB No.	RB offset	MPR	Conducted Output Power (dBm)	RF Output Power (W) EIRP	Limit (W) EIRP
Band 41 15MHz	39765 2507.5	QPSK	1	0	0	21.35	0.216	2
		QPSK		37		21.23	0.210	2
		QPSK		74		21.14	0.206	2
		QPSK	75	0	1	20.32	0.171	2
	39725 2503.5	64-QAM	1	0	1	20.64	0.184	2
		64-QAM		37		20.51	0.178	2
		64-QAM		74		20.43	0.175	2
		64-QAM	75	0	2	19.41	0.138	2
	39725 2503.5	64-QAM	1	0	0	20.49	0.177	2
		64-QAM		37		20.36	0.172	2
		64-QAM		74		20.32	0.171	2
		64-QAM	75	0	1	19.32	0.136	2

Note:

1. Measure Level (EIRP) = Reading Level (dBm) + Antenna Gain(dBi)
2. power (W)=  $(10^{(\text{power(dBm)}/10)}) * 10^{-3}$

Band	Channel Freq. (MHz)	Modulation	RB No.	RB offset	MPR	Conducted Output Power (dBm)	RF Output Power (W) EIRP	Limit (W) EIRP
Band 41 20MHz	39790	QPSK	1	0	0	21.51	0.224	2
		QPSK		49		21.37	0.217	2
		QPSK		99		21.32	0.215	2
		QPSK	100	0	1	20.44	0.175	2
	2510	16-QAM	1	0	1	20.46	0.176	2
		16-QAM		49		20.37	0.173	2
		16-QAM		99		20.30	0.170	2
		16-QAM	100	0	2	19.39	0.138	2
	39750 2506	64-QAM	1	0	0	20.58	0.181	2
		64-QAM		49		20.44	0.175	2
		64-QAM		99		20.42	0.175	2
		64-QAM	100	0	1	19.36	0.137	2

Note:

1. Measure Level (EIRP) = Reading Level (dBm) + Antenna Gain(dBi)
2. power (W)=  $(10^{(\text{power(dBm)}/10)}) * 10^{-3}$

Product	Module		
Test Item	RF Output Power		
Test Mode	Mode 10: LTE Band 71		
Date of Test	2020/08/19	Test Site	SR12-H
Temperature(°C)	23	Humidity (%RH)	67

Band	Channel Freq. (MHz)	Modulation	RB No.	RB offset	MPR	Conducted Output Power (dBm)	RF Output Power (W) ERP	Limit (W) ERP
Band 71 5MHz	133147 665.5	QPSK	1	0	0	22.92	0.189	3
		QPSK		12		23.20	0.202	3
		QPSK		24		23.06	0.195	3
		QPSK	25	0	1	21.94	0.151	3
		16-QAM	1	0	1	22.35	0.166	3
		16-QAM		12		22.42	0.169	3
		16-QAM		24		22.22	0.161	3
		16-QAM	25	0	2	20.94	0.120	3
	133297 680.5	QPSK	1	0	0	23.07	0.196	3
		QPSK		12		22.80	0.184	3
		QPSK		24		22.92	0.189	3
		QPSK	25	0	1	21.89	0.149	3
		16-QAM	1	0	1	22.10	0.157	3
		16-QAM		12		22.14	0.158	3
		16-QAM		24		22.08	0.156	3
		16-QAM	25	0	2	20.92	0.119	3
	133447 695.5	QPSK	1	0	0	22.87	0.187	3
		QPSK		12		22.94	0.190	3
		QPSK		24		22.81	0.185	3
		QPSK	25	0	1	21.73	0.144	3
		16-QAM	1	0	1	21.67	0.142	3
		16-QAM		12		21.79	0.146	3
		16-QAM		24		21.65	0.141	3
		16-QAM	25	0	2	20.76	0.115	3

Band	Channel Freq. (MHz)	Modulation	RB No.	RB offset	MPR	Conducted Output Power (dBm)	RF Output Power (W) ERP	Limit (W) ERP
Band 71 5MHz	133147 665.5	64-QAM	1	0	0	22.11	0.157	3
		64-QAM		12		21.88	0.149	3
		64-QAM		24		21.94	0.151	3
		64-QAM	25	0	1	20.52	0.109	3
	133297 680.5	64-QAM	1	0	0	21.83	0.147	3
		64-QAM		12		21.69	0.143	3
		64-QAM		24		21.74	0.144	3
		64-QAM	25	0	1	20.34	0.104	3
	133447 695.5	64-QAM	1	0	0	21.96	0.152	3
		64-QAM		12		21.73	0.144	3
		64-QAM		24		21.82	0.147	3
		64-QAM	25	0	1	20.31	0.104	3

Note:

1. Measure Level (ERP) = Reading Level (dBm) + Antenna Gain(dBi)-2.15dB
2. power (W)=  $(10^{(\text{power(dBm)}/10)}) * 10^{-3}$

Band	Channel Freq. (MHz)	Modulation	RB No.	RB offset	MPR	Conducted Output Power (dBm)	RF Output Power (W) ERP	Limit (W) ERP		
Band 71 10MHz	133172 668	QPSK	1	0	0	22.97	0.191	3		
		QPSK		24		22.89			0.188	3
		QPSK		49		22.78			0.183	3
		QPSK	50	0	1	21.97	0.152	3		
		16-QAM		1	0	22.14	0.158	3		
		16-QAM			24	22.10	0.157	3		
		16-QAM			49	22.00	0.153	3		
		16-QAM	50	0	2	20.98	0.121	3		
	133297 680.5	QPSK	1	0	0	23.03	0.194	3		
		QPSK		24		22.99			0.192	3
		QPSK		49		22.81			0.185	3
		QPSK	50	0	1	21.90	0.150	3		
		16-QAM		1	0	22.12	0.157	3		
		16-QAM			24	22.11	0.157	3		
		16-QAM			49	21.99	0.153	3		
		16-QAM	50	0	2	20.85	0.117	3		
	133422 693	QPSK	1	0	0	22.68	0.179	3		
		QPSK		24		22.73			0.181	3
		QPSK		49		22.62			0.177	3
		QPSK	50	0	1	21.75	0.145	3		
		16-QAM		1	0	21.80	0.146	3		
		16-QAM			24	21.84	0.148	3		
		16-QAM			49	21.68	0.142	3		
		16-QAM	50	0	2	20.76	0.115	3		

Band	Channel Freq. (MHz)	Modulation	RB No.	RB offset	MPR	Conducted Output Power (dBm)	RF Output Power (W) ERP	Limit (W) ERP
Band 71 10MHz	133172 668	64-QAM	1	0	0	22.07	0.156	3
		64-QAM		24		21.91	0.150	3
		64-QAM		49		21.94	0.151	3
		64-QAM	50	0	1	20.64	0.112	3
	133297 680.5	64-QAM	1	0	0	22.02	0.154	3
		64-QAM		24		21.82	0.147	3
		64-QAM		49		21.77	0.145	3
		64-QAM	50	0	1	20.48	0.108	3
	133422 693	64-QAM	1	0	0	22.03	0.154	3
		64-QAM		24		21.85	0.148	3
		64-QAM		49		21.81	0.147	3
		64-QAM	50	0	1	20.49	0.108	3

Note:

1. Measure Level (ERP) = Reading Level (dBm) + Antenna Gain(dBi)-2.15dB
2. power (W)=  $(10^{(\text{power(dBm)}/10)}) * 10^{-3}$

Band	Channel Freq. (MHz)	Modulation	RB No.	RB offset	MPR	Conducted Output Power (dBm)	RF Output Power (W) ERP	Limit (W) ERP			
Band 71 15MHz	133197 670.5	QPSK	1	0	0	22.94	0.190	3			
		QPSK		37		22.88			0.187	3	
		QPSK		74		22.78			0.183	3	
		QPSK	75	1	0	1	21.91	0.150	3		
		16-QAM			0		22.19			0.160	3
		16-QAM			37		22.11			0.157	3
		16-QAM			74		22.07			0.156	3
		16-QAM	75	2	20.93	0.120	3				
	133297 680.5	QPSK	1	0	0	22.94	0.190	3			
		QPSK		37		23.00			0.193	3	
		QPSK		74		22.82			0.185	3	
		QPSK	75	1	0	1	21.88	0.149	3		
		16-QAM			0		22.04			0.155	3
		16-QAM			37		22.08			0.156	3
		16-QAM			74		21.93			0.151	3
		16-QAM	75	2	20.97	0.121	3				
	133397 690.5	QPSK	1	0	0	22.86	0.187	3			
		QPSK		37		22.82			0.185	3	
		QPSK		74		22.65			0.178	3	
		QPSK	75	1	0	1	21.82	0.147	3		
		16-QAM			0		22.11			0.157	3
		16-QAM			37		22.09			0.156	3
		16-QAM			74		21.83			0.147	3
		16-QAM	75	2	20.82	0.117	3				

Band	Channel Freq. (MHz)	Modulation	RB No.	RB offset	MPR	Conducted Output Power (dBm)	RF Output Power (W) ERP	Limit (W) ERP
Band 71 15MHz	133197 670.5	64-QAM	1	0	0	22.03	0.154	3
		64-QAM		37		21.96	0.152	3
		64-QAM		74		21.90	0.150	3
		64-QAM	75	0	1	20.46	0.107	3
	133297 680.5	64-QAM	1	0	0	21.97	0.152	3
		64-QAM		37		21.88	0.149	3
		64-QAM		74		21.77	0.145	3
		64-QAM	75	0	1	20.43	0.107	3
	133397 690.5	64-QAM	1	0	0	22.00	0.153	3
		64-QAM		37		21.93	0.151	3
		64-QAM		74		21.89	0.149	3
		64-QAM	75	0	1	20.42	0.106	3

Note:

1. Measure Level (ERP) = Reading Level (dBm) + Antenna Gain(dBi)-2.15dB
2. power (W)=  $(10^{(\text{power(dBm)}/10)}) * 10^{-3}$