



中国认可
国际互认
检测
TESTING
CNAS L5313



DEKRA

FCC Part22H & 24E & 27 F&L&M Test Report

Product Name : Module
Model No. : AR7582
FCC ID : N7NAR7582
IC : 2417C-AR7582

Applicant : Sierra Wireless Inc.

Address : 13811 Wireless Way, Richmond, BC, V6V 3A4 Canada

Date of Receipt : Feb. 21st, 2017
Test Date : Feb. 21st, 2017~ Mar. 30th, 2017
Issued Date : Apr. 10th, 2017
Report No. : 1720509R-HP-US-P07V01
Report Version : V1.0

The test results relate only to the samples tested.

The test results shown in the test report are traceable to the national/international standard through the calibration of the equipment and evaluated measurement uncertainty herein.

This report must not be used to claim product endorsement by TAF, CNAS or any agency of the government.

The test report shall not be reproduced without the written approval of DEKRA Testing & Certification (Suzhou) Co., Ltd.

Test Report Certification

Issued Date : Apr. 10th, 2017

Report No. :1720509R-HP-US-P07V01



Product Name : Module
 Applicant : Sierra Wireless Inc.
 Address : 13811 Wireless Way, Richmond, BC, V6V 3A4 Canada
 Manufacturer : Sierra Wireless Inc.
 Address : 13811 Wireless Way, Richmond, BC, V6V 3A4 Canada
 Model No. : AR7582
 FCC ID : N7NAR7582
 IC : 2417C-AR7582
 EUT Voltage : Low: 3.4V, High: 4.2V, Normal: 3.7V
 Brand Name : AirPrime
 Applicable Standard : FCC CFR Title 47 Part 2, TIA/EIA 603-C
 FCC Part22 Subpart H
 FCC Part24 Subpart E
 FCC Part 27 Subpart L&F&M
 Industry Canada RSS-GEN, Issue 4
 Industry Canada RSS-132, Issue 3
 Industry Canada RSS-133, Issue 6
 Industry Canada RSS-139, Issue 3
 Industry Canada RSS-130, Issue 1
 Industry Canada RSS-199, Issue 2

Test Result : Complied
 Performed Location : DEKRA Testing and Certification (Suzhou) Co., Ltd.
 No.99 Hongye Rd., Suzhou Industrial Park, Suzhou,215006,
 Jiangsu,China
 TEL:+86-512-6251-5088 / FAX:+86-512-6251-5098
 FCC Registration Number: 800392, IC Lab Code: 4075B

Documented By : Kitty Li
 (Adm. Specialist: Kitty Li)

Reviewed By : Frank He
 (Senior Engineer: Frank He)

Approved By : Harry Zhao
 (Engineering Manager: Harry Zhao)

TABLE OF CONTENTS

Description	Page
1. General Information	5
1.1. EUT Description	5
1.2. Mode of Operation	6
1.3. Tested System Details	7
1.4. Configuration of Tested System	7
1.5. EUT Exercise Software	8
2. Summary Technical Test	9
2.1. Limit and Test Result	9
2.3. Test Environment	23
2.4. Measurement Uncertainty	23
3. Maximum Output Power and Effectivelsotropic Radiated PowerMeasurement	24
3.1. Test Equipment	24
3.2. Test Setup	25
3.3. Test Procedure	26
3.4. Test Result	27
4. Occupied Bandwidth	50
4.1. Test Equipment	57
4.2. Test Setup	57
4.3. Test Procedure	57
4.4. Test Result	58
5. Conducted Band Edge	66
5.1. Test Equipment	66
5.2. Test Procedure	66
5.3. Test Result	67
6. Spurious Emission	77
6.1. Test Equipment	77
6.2. Test Setup	78
6.3. Test Procedure	79
6.4. Test Result	80
7. Frequency Stability Under Temperature & Voltage Variations	116
7.1. Test Equipment	116
7.2. Test Setup	116
7.3. Test Procedure	117
7.4. Test Result	118

History of This Test Report

REPORT NO.	VERSION	DESCRIPTION	ISSUED DATE
1720509R-HP-US-P07V01	V1.0	Initial Issued Report	Apr. 10th, 2017

1. General Information

1.1. EUT Description

Product Name	Module
Model No.	AR7582
Brand Name	AirPrime
EUT Voltage	Low: 3.4V, High: 4.2V, Normal: 3.7V
HW	1.0
SW	SWI9X28A_00.04.03.00.
4G	
Support Band	LTE Band 2/4/5/7/12/13/17
Uplink	Band 2: 1850-1910MHz Band 4: 1710~1755MHz Band 5: 824-849MHz Band 7: 2500~2570MHz Band 12: 699~716MHz Band 13: 777-787MHz Band 17: 704-716MHz
Downlink	Band 2: 1930-1990MHz Band 4: 2110~2155MHz Band 5: 869-894MHz Band 7:2620~2690mMHz Band 12:729~746MHz Band 13: 746-756MHz Band 17: 734-746MHz
Type of modulation	QPSK, 16QAM
Antenna Type	Dipole
Antenna Gain	Band 2:1.3dBi Band 4: 1.3dBi Band 5: 1.2dBi Band 7: 1.3dBi Band 12: 1.2dBi Band 13: 1.2dBi Band 17: 1.2dBi

1.2. Mode of Operation

We have verified the construction and function in typical operation. All the test modes were carried out with the EUT in normal operation, which was shown in this test report and defined as:

Test Mode
Mode 1 :LTE Band 2 Link
Mode 2 :LTE Band 4 Link
Mode 3 :LTE Band 5 Link
Mode 4 :LTE Band 7 Link
Mode 5 : LTE Band 12 Link
Mode 6:LTE Band 13 Link
Mode 7:LTE Band 17 Link
Note 1: Regards to the frequency band operation: the lowest, middle and highest frequency of channel were selected to perform the test, then shown on this report. For the LTE band, we also evaluate the each channel of bandwidth, RB offset and modulation, we will choose the worst case shown on this report.

1.3. Tested System Details

The types for all equipment, plus descriptions of all cables used in the tested system (including inserted cards) are:

Product	Manufacturer	Model No.	Serial No.	Power Cord
1 DC Power Supply	IDRC	CD-035-020PR	977272	N/A
2 Radio Communication Tester	Anritsu	MT8820C	6201181503	N/A

1.4. Configuration of Tested System

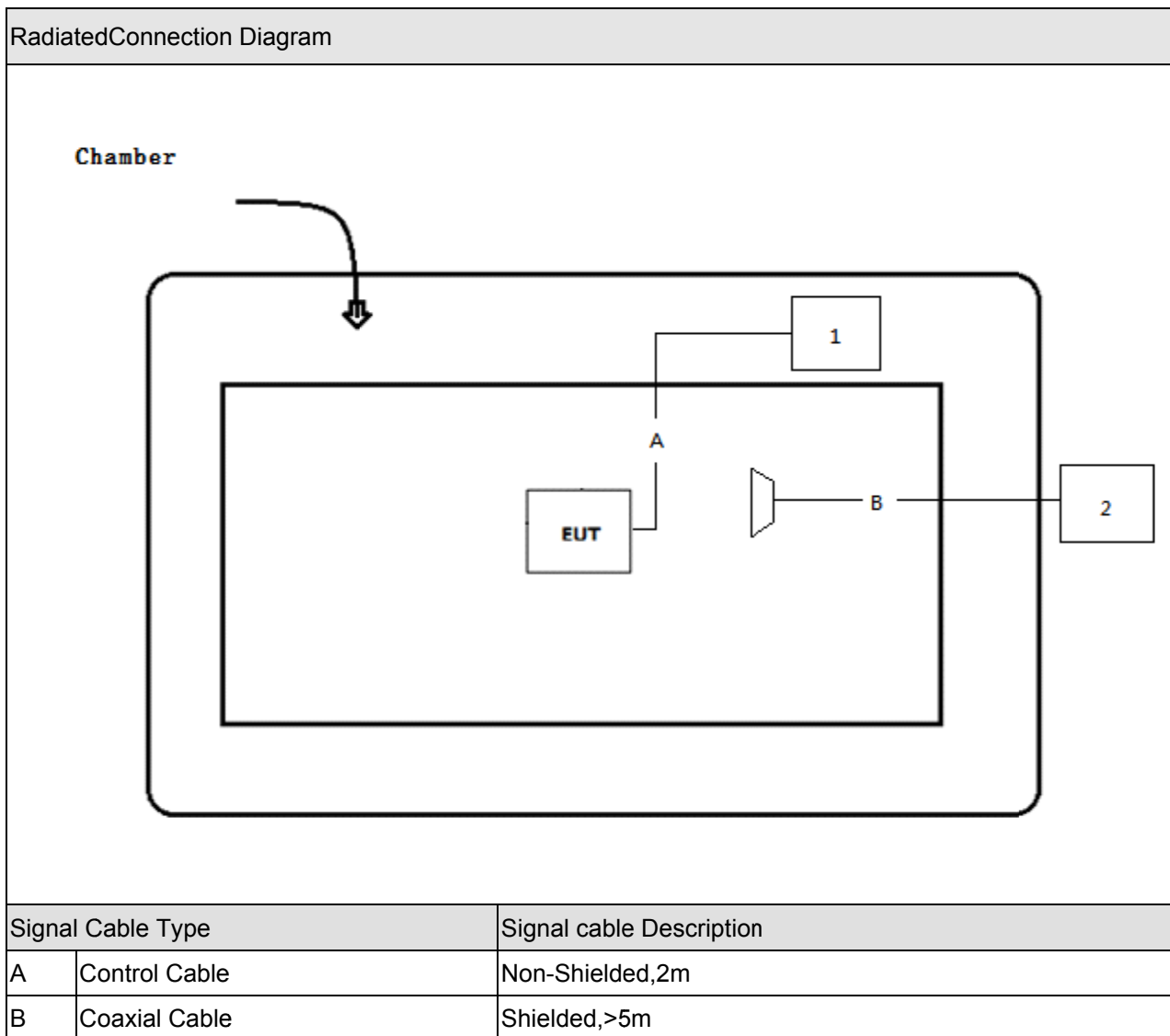

Conducted Connection Diagram

Chamber

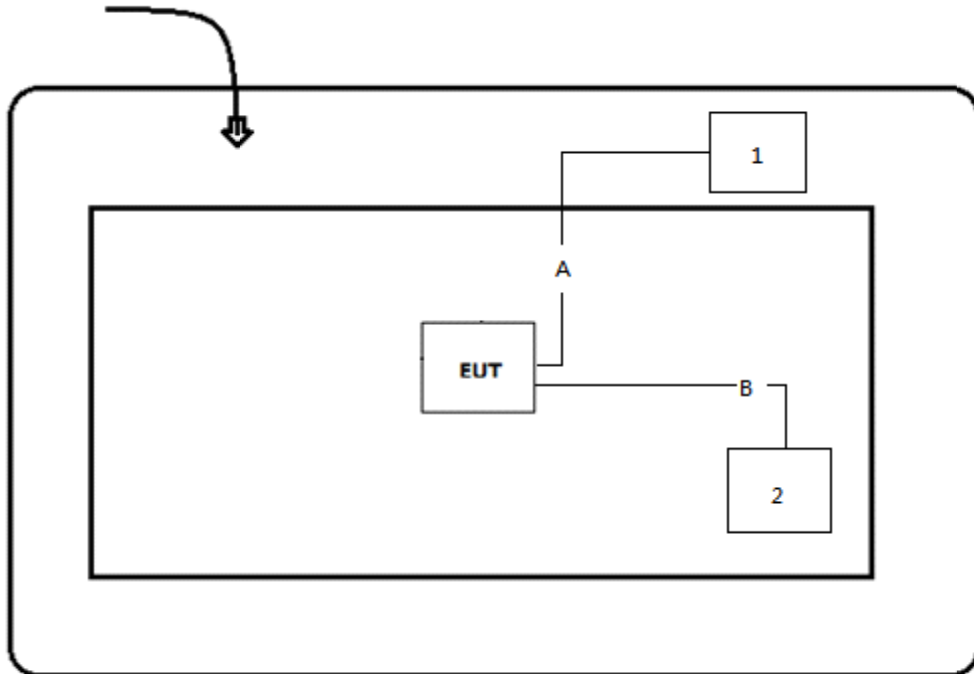

Signal Cable Type	Signal cable Description	
A	Control Cable	Non-Shielded,2m
B	Coaxial Cable	Shielded,>5m

1.5. EUT Exercise Software

1	Setup the EUT and simulators as shown on above.
2	Turn on the power of all equipment.
3	EUT Communicate with MT8820C, then select channel to test.

2. Summary Technical Test

2.1. Limit and Test Result

LTE Band 2					
FCC Part 24 Subpart E					
Industry Canada RSS-133, Issue 6, Industry Canada RSS-GEN					
Test Item	FCC Reference section	FCC Limit	IC Reference section	IC Limit	Result
Maximum Output Power	§2.1033 §2.1046 §24.232	< 2 Watts	§6.4	< 2 Watts	Pass
Equivalent Isotropic Radiated Power	§24.232	< 2 Watts	§6,4	< 2 Watts	Pass
Peak-to-average power ratio	§24.232	< 13dB	§6.4	< 13dB	Pass
Occupied Bandwidth	§2.1049	N/A	RSS-GEN §4.2	N/A	Pass
Conducted Band Edge Emissions	§27.238	<-13dBm	§6.5	<-13dBm	Pass
Spurious Radiation	§2.1053 §24.238	<-13dBm	§6.5	<-13dBm	Pass
Frequency Stability Under Temperature & Voltage Variations	§2.1055 §24.235	< 2.5 ppm	§6.3	< 2.5 ppm	Pass

LTE Band 4					
FCC Part 27 Subpart L					
Industry Canada RSS-139, Issue 3, Industry Canada RSS-GEN					
Test Item	FCC Reference section	FCC Limit	IC Reference section	IC Limit	Result
Maximum Output Power	§2.1033	<1 Watts	§6.5	<1 Watts	Pass
	§2.1046				
	§27.50				
Equivalent Isotropic Radiated Power	§27.50	<1 Watts	§6,5	<1 Watts	Pass
Peak-to-average power ratio	§27.50	< 13dB	§6.5	< 13dB	Pass
Occupied Bandwidth	§2.1049	N/A	RSS-GEN §4.2	N/A	Pass
Conducted Band EdgeEmissions	§27.53	<-13dBm	§6.6	<-13dBm	Pass
Spurious Radiation	§2.1053	<-13dBm	§6.6	<-13dBm	Pass
	§27.53				
Frequency Stability Under Temperature & Voltage Variations	§2.1055 §27.54	<2.5 ppm	§6.4	within the frequency range	Pass

LTE Band 5					
FCC Part 22 Subpart H					
Industry Canada RSS-132, Issue 3, Industry Canada RSS-GEN					
Test Item	FCC Reference section	FCC Limit	IC Reference section	IC Limit	Result
Maximum Output Power	§2.1033 §2.1046 §22.913	<7 Watts	§5.4	<7 Watts	Pass
Equivalent Isotropic Radiated Power	§22.913	<7 Watts	§5.4	<11.5 Watts	Pass
Occupied Bandwidth	§2.1049	N/A	RSS-GEN §4.2	N/A	Pass
Conducted Band Edge Emissions	§22.917	<-13dBm	§5.5	<-13dBm	Pass
Spurious Radiation	§2.1053 §§22.917	<-13dBm	§5.5	<-13dBm	Pass
Frequency Stability Under Temperature & Voltage Variations	§2.1055 §22.335	< 2.5 ppm	§5.3	< 2.5 ppm	Pass

LTE Band 7					
FCC Part 27 SubpartM					
Industry Canada RSS-199, Issue 2, Industry Canada RSS-GEN					
Test Item	FCC Reference section	Limit	IC Reference section	Limit	Result
Maximum Output Power	§2.1033 §2.1046 §27.50	Output Power < 2 Watts	§5.4	Output Power < 2 Watts	Pass
Equivalent Isotropic Radiated Power	§27.50	< 33 dBW + 10 log(X/Y)dBW + 10 log(360/beamwidth) dBW	§5.4	< 33 dBW + 10 log(X/Y)dBW + 10 log(360/beamwidth) dBW	Pass
Occupied Bandwidth	§2.1049	N/A	RSS-GEN §4.2	N/A	Pass
Conducted Band EdgeEmissions	§27.53	< 5MHz: -10dBm 5MHz-X MHz:-13dBm >X MHz:-25dBm	§5.5	< 5MHz: -10dBm 5MHz-X MHz:-13dBm >X MHz:-25dBm	Pass
Spurious Radiation	§2.1053 §27.53	-25 dBm	§5.5	-25 dBm	Pass
Frequency Stability Under Temperature & Voltage Variations	§2.1055 §27.54	2.5 ppm	§5.3	2.5 ppm	Pass

LTE Band 12					
FCC Part 27 Subpart F					
Industry Canada RSS-130, Issue 1, Industry Canada RSS-GEN					
Test Item	FCC Reference section	FCC Limit	IC Reference section	IC Limit	Result
Maximum Output Power	§2.1033 §2.1046 §27.50	<3 Watts	§4.4	<5 Watts	Pass
Equivalent Isotropic Radiated Power	§27.50	<3 Watts	§4.4	<5 Watts	Pass
Occupied Bandwidth	§2.1049	N/A	RSS-GEN	N/A	Pass
Conducted Band Edge Emissions	§27.53	<-13dBm	§4.6	<-13dBm	Pass
Spurious Radiation	§2.1053 §27.53	<-13dBm	§4.6	<-13dBm	Pass
Frequency Stability Under Temperature & Voltage Variations	§2.1055 §27.54	< 2.5 ppm	§4.3	within the frequency range	Pass

LTE Band 13					
FCC Part 27 Subpart F					
Industry Canada RSS-130, Issue 1, Industry Canada RSS-GEN					
Test Item	FCC Reference section	FCC Limit	IC Reference section	IC Limit	Result
Maximum Output Power	§2.1033 §2.1046 §27.50	<3 Watts	§4.4	<5 Watts	Pass
Equivalent Isotropic Radiated Power	§27.50	<3 Watts	§4.4	<5 Watts	Pass
Occupied Bandwidth	§2.1049	N/A	RSS-GEN	N/A	Pass
Conducted Band Edge Emissions	§27.53	<-13dBm	§4.6	<-13dBm	Pass
Spurious Radiation	§2.1053 §27.53	<-13dBm	§4.6	<-13dBm	Pass
Frequency Stability Under Temperature & Voltage Variations	§2.1055 §27.54	< 2.5 ppm	§4.3	within the frequency range	Pass

LTE Band 17					
FCC Part 27 Subpart F					
Industry Canada RSS-130, Issue 1, Industry Canada RSS-GEN					
Test Item	FCC Reference section	FCC Limit	IC Reference section	IC Limit	Result
Maximum Output Power	§2.1033 §2.1046 §27.50	<3 Watts	§4.4	<5 Watts	Pass
Equivalent Isotropic Radiated Power	§27.50	<3 Watts	§4.4	<5 Watts	Pass
Occupied Bandwidth	§2.1049	N/A	RSS-GEN	N/A	Pass
Conducted Band Edge Emissions	§27.53	<-13dBm	§4.6	<-13dBm	Pass
Spurious Radiation	§2.1053 §27.53	<-13dBm	§4.6	<-13dBm	Pass
Frequency Stability Under Temperature & Voltage Variations	§2.1055 §27.54	< 2.5 ppm	§4.3	within the frequency range	Pass

2.2. Worst Data

Test Item	LTE Band	Bandwidth	Channel	Frequency	RB Size	RB Offset	Value
Maximum Output Power	2	20M	19100	1900	1	49	22.19
		15M	19125	1902.5	1	37	21.99
		10M	18650	1855	1	24	22.03
		5M	19175	1907.5	1	12	22.14
		3M	19185	1908.5	1	0	22.19
		1.4M	19193	1909.3	1	2	22.31
	4	20M	20300	1745	1	49	22.69
		15M	20175	1732.5	1	0	22.34
		10M	20350	1750	1	24	22.54
		5M	20175	1732.5	1	12	22.27
		3M	20175	1732.5	1	0	22.38
		1.4M	20175	1732.5	1	0	22.37
	5	10M	20450	829	1	24	23.53
		5M	20425	826.5	1	12	23.38
		3M	20415	825.5	1	7	23.51
		1.4M	20407	824.7	3	0	23.48
	7	20M	21350	2560	1	49	21.73
		15M	20825	2507.5	1	37	21.85
		10M	20800	2505	1	24	21.92
		5M	20775	2502.5	1	12	21.66
	12	10M	23130	711	1	24	23.28
		5M	23035	701.5	1	12	23.05
		3M	23095	707.5	1	0	23.09
		1.4M	23095	707.5	1	0	23.40
	13	10M	23790	710	1	24	23.31
		5M	23825	713.5	1	12	23.31
	17	10M	23800	711	1	24	23.37
		5M	23755	706.5	1	12	23.03

Note: The modulation of the worst data is QPSK

Test Item	LTE Band	Bandwidth	Channel	Frequency	RB Size	RB Offset	Value
Equivalent Isotropic Radiated Power	2	20M	18900	1880	1	0	24.33
		15M	18900	1880	1	0	24.18
		10M	18650	1855	1	0	24.31
		5M	18900	1880	1	0	24.47
		3M	19185	1908.5	1	0	25.07
		1.4M	18607	1850.7	1	0	24.13
	4	20M	20050	1720	1	0	24.44
		15M	20025	1717.5	1	0	24.54
		10M	20350	1750	1	0	24.65
		5M	19975	1712.5	1	0	24.21
		3M	20175	1732.5	1	0	24.26
		1.4M	19957	1710.7	1	0	24.14
	5	10M	20450	829	1	0	24.53
		5M	20425	826.5	1	0	24.45
		3M	20415	825.5	1	0	24.53
		1.4M	20525	836.5	1	0	24.51
	7	20M	21350	2560	1	0	24.27
		15M	20825	2507.5	1	0	24.62
		10M	20800	2505	1	0	24.60
		5M	20775	2502.5	1	0	24.37
	12	10M	23130	711	1	0	24.94
		5M	23095	707.5	1	0	24.13
		3M	23095	707.5	1	0	24.41
		1.4M	23017	699.7	1	0	24.28
	13	10M	23230	782	1	0	24.89
		5M	23230	782	1	0	24.49
	17	10M	23790	711	1	0	24.34
		5M	23755	706.5	1	0	24.49
Note: The modulation of the worst data is QPSK							

Test Item	LTE Band	Bandwidth	Channel	Frequency	RB Size	RB Offset	Value
Peak-to-average power ratio	2	20M	18900	1880	100	0	6.41
		15M	18900	1880	75	0	6.37
		10M	19150	1905	50	0	6.47
		5M	18900	1880	25	0	6.37
		3M	19185	1908.5	15	0	6.43
		1.4M	19193	1909.3	6	0	6.41
	4	20M	20175	1732.5	100	0	6.50
		15M	20175	1732.5	75	0	6.51
		10M	20175	1732.5	50	0	6.51
		5M	19975	1712.5	25	0	6.46
		3M	19965	1711.5	15	0	6.33
		1.4M	19957	1710.7	6	0	6.54

Note: The modulation of the worst data is 16QAM

Test Item	LTE Band	Bandwidth	Channel	Frequency	RB Size	RB Offset	Value	
Occupied Bandwidth	2	20M	19100	1900	100	0	17845	
		15M	18900	1880	75	0	13388	
		10M	18900	1880	50	0	8923.1	
		5M	19175	1907.5	25	0	4478.8	
		3M	18615	1851.5	15	0	2681.0	
		1.4M	18900	1880	7	0	1079.4	
	4	20M	20300	1745	100	0	17872	
		15M	20325	1747.5	75	0	13385	
		10M	20350	1750	50	0	8937.4	
		5M	20375	1752.5	25	0	4471.2	
		3M	20385	1753.5	15	0	2682.6	
		1.4M	19957	1710.7	7	0	1081.8	
	5	10M	20600	844	50	0	8938.6	
		5M	20525	836.5	25	0	4466.8	
		3M	20635	847.5	15	0	2689.2	
		1.4M	20407	824.7	7	0	1083.8	
	7	20M	20850	2510	100	0	17875	
		15M	20825	2507.5	75	0	13386	
		10M	21100	2535	50	0	8923.6	
		5M	21425	2567.5	15	0	4470.1	
	12	10M	23130	711	50	0	8928.6	
		5M	23155	713.5	15	0	4474.1	
		3M	23025	700.5	15	0	2687.6	
		1.4M	23017	699.7	7	0	1079.1	
	13	10M	23230	782	50	0	8895.6	
		5M	23205	779.5	25	0	4464.1	
	17	10M	23790	710	50	0	8941.2	
		5M	23825	713.5	25	0	4469	
	Note: The modulation of the worst data is QPSK							

Test Item	LTE Band	Bandwidth	Channel	Frequency	RB Size	RB Offset	Value
Conducted Band Edge Emissions	2	20M	19100	1900	100	0	-25.012
		15M	19125	1902.5	1	74	-23.942
		10M	19150	1905	1	49	-15.078
		5M	18625	1852.5	25	0	-14.550
		3M	19185	1908.5	15	0	-13.872
		1.4M	18607	1850.7	1	0	-13.729
	4	20M	20300	1745	100	0	-23.383
		15M	20325	1747.5	75	0	-22.377
		10M	20000	1715	1	0	-14.572
		5M	20375	1752.5	25	0	-15.113
		3M	19965	1711.5	1	0	-13.464
		1.4M	20393	1754.3	7	0	-16.619
	5	10M	20450	829	50	0	-33.078
		5M	20425	826.5	1	0	-24.181
		3M	20635	847.5	1	14	-23.407
		1.4M	20643	848.3	1	6	-27.473
	7	20M	21350	2560	100	0	-24.200
		15M	21400	2562.5	75	0	-27.320
		10M	20800	2505	50	0	-14.328
		5M	20775	2502.5	25	0	-15.249
	12	10M	23130	711	50	0	-32.564
		5M	23155	713.5	1	24	-23.802
		3M	23165	714.5	1	14	-21.398
		1.4M	23173	715.3	1	6	-25.870
	13	10M	23230	782	50	0	-32.341
		5M	23205	779.5	1	0	-22.321
	17	10M	23780	709	50	0	-31.292
		5M	23755	706.5	1	0	-22.976
Note: The modulation of the worst data is QPSK							

Test Item	LTE Band	Bandwidth	Channel	Frequency	RB Size	RB Offset	Value
Field Strength of Spurious Radiation	2	20M	18900	1880	1	0	-58.623
		15M	19125	1902.5	1	0	-58.062
		10M	18900	1880	1	0	-58.292
		5M	18625	1852.5	1	0	-58.509
		3M	18900	1880	1	0	-58.015
		1.4M	18607	1850.7	1	0	-58.245
	4	20M	20175	1732.5	1	0	-58.071
		15M	20325	1747.5	1	0	-58.172
		10M	20000	1715	1	0	-57.547
		5M	19975	1712.5	1	0	-58.134
		3M	20175	1732.5	1	0	-58.046
		1.4M	20175	1732.5	1	0	-57.436
	5	10M	20450	829	1	0	-48.978
		5M	20525	836.5	1	0	-48.739
		3M	20525	836.5	1	0	-48.582
		1.4M	20525	836.5	1	0	-49.675
	7	20M	21350	2560	1	0	-52.255
		15M	20825	2507.5	1	0	-53.172
		10M	21400	2565	1	0	-52.659
		5M	20775	2502.5	1	0	-51.709
	12	10M	23130	711	1	49	-49.313
		5M	23155	713.5	1	12	-50.268
		3M	23025	700.5	1	7	-49.454
		1.4M	23173	715.3	1	5	-50.391
	13	10M	20535	836.5	1	0	-50.657
		5M	23230	782	1	0	-49.368
	17	10M	23790	710	1	0	-49.153
		5M	23790	710	1	0	-49.814
Note: The modulation of the worst data is QPSK							

Test Item	LTE Band	Bandwidth	Channel	Frequency	RB Size	RB Offset	Value
Frequency Stability Under Temperature & Voltage Variations	2	20M	18900	1880	1	0	95
	4	20M	20175	1732.5	1	0	-87
	5	10M	20525	836.5	1	0	92
	7	20M	21100	2535	1	0	-95
	12	10M	23095	707.5	1	0	-89
	13	10M	23230	782	1	0	-73
	17	10M	23790	710	1	0	84

Note: The modulation of the worst data is QPSK

2.3. Test Environment

Items	Required (IEC 68-1)	Actual
Temperature (°C)	15-35	23
Humidity (%RH)	25-75	52
Barometric pressure (mbar)	860-1060	950-1000

2.4. Measurement Uncertainty

Items	Uncertainty
Maximum Output Power	±1.2 dB
Equivalent Isotropic Radiated Power	±3.2 dB
Occupied Bandwidth	±10 Hz
Conducted Band Edge Emissions	±1.2 dB
Field Strength of Spurious Radiation	±3.2 dB
Frequency Stability Under Temperature & Voltage Variations	±10 Hz

3. Maximum Output Power and Effective Isotropic Radiated Power Measurement

3.1. Test Equipment

Maximum Output Power and Effective Isotropic Radiated Power Measurement / AC-5				
Instrument	Manufacturer	Type No.	Serial No	Cali. Due Date
PSA Series Spectrum Analyzer	Agilent	E4440A	MY49420184	2018.02.04
Radio Communication Tester	Anritsu	MT8820C	6201181503	2017.09.16
Dual Directional Coupler	Agilent	778D	20160	2018.02.04
10dB Coaxial Coupler	Agilent	87300C	MY44300299	2018.03.28
PSG Analog Signal Generator	Agilent	E8257D	MY44321116	2018.02.04
Preamplifier	QuieTek	AP-025C	CHM-0503006	2017.04.11
Preamplifier	Miteq	NSP1800-25	1364185	2017.05.03
Bilog Antenna	Teseq GmbH	CBL6112D	27612	2018.01.23
Half Wave Tuned Dipole Antenna	COM-POWER	AD-100	40137	2018.02.26
Broad-Band Horn Antenna	Schwarzbeck	BBHA9120D	737	2018.03.06
DRG Horn	ETS-Lindgren	3117	00167055	2017.07.23
Temperature/Humidity Meter	Zhicheng	ZC1-2	AC5-TH	2018.01.05

3.2. Test Setup

Conducted Power Measurement:

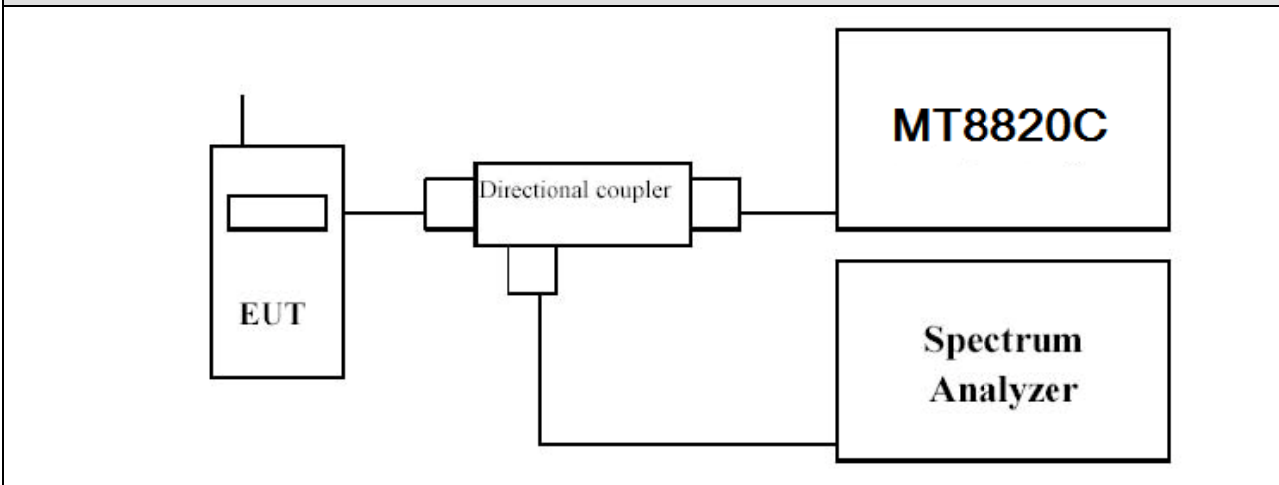

Radiated Power Measurement (Below 1G):

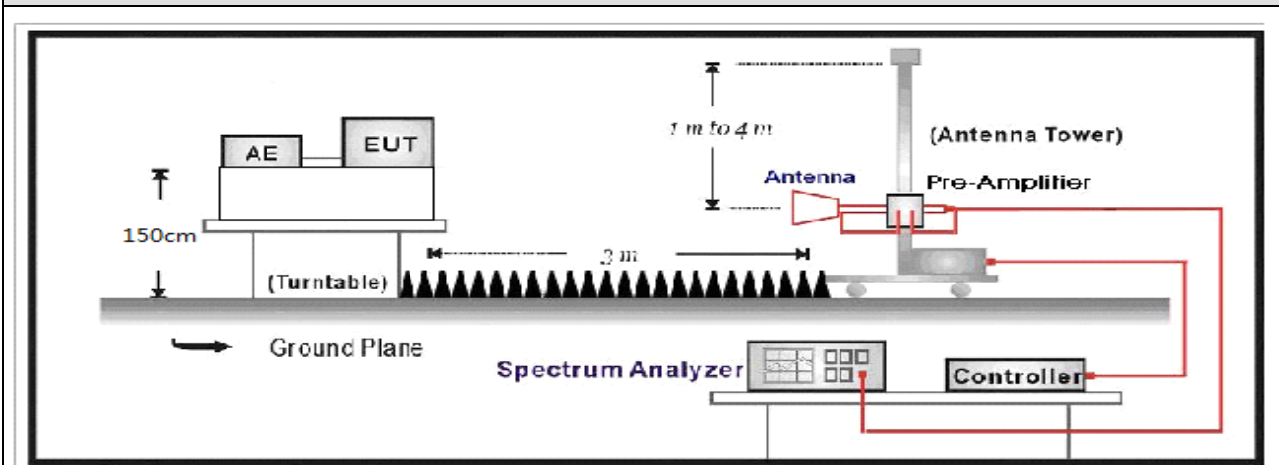

Radiated Power Measurement (Above 1G):

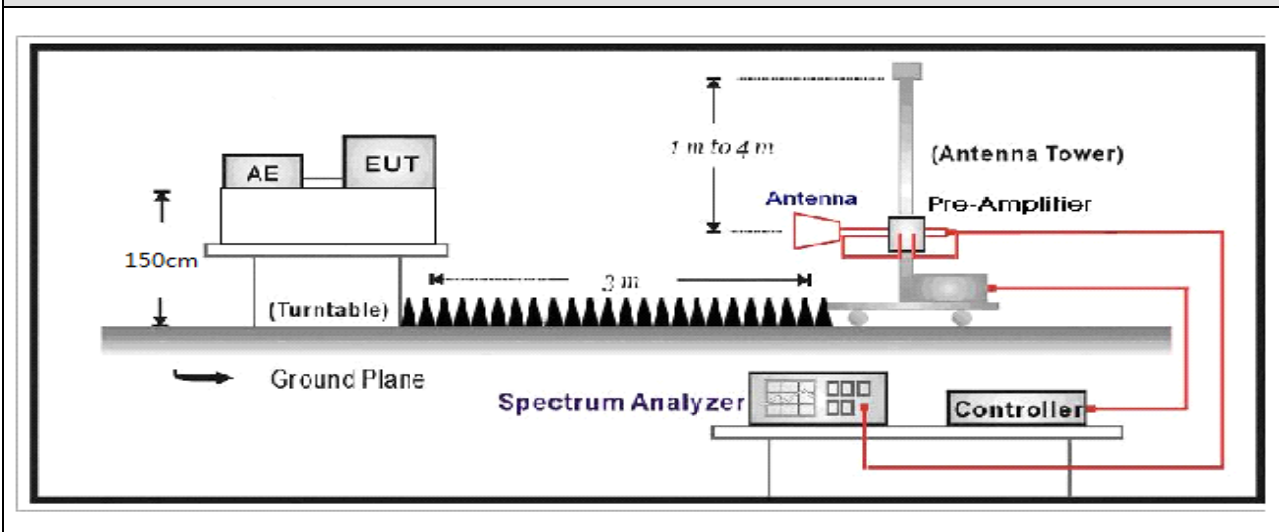

3.3. Test Procedure

Test Method for conducted power

- a) The RF output of the transmitter was connected to base station simulator.
- b) The RF output of EUT was connected to the spectrum analyzer by RF cable and attenuator.
The path loss was compensated to the results for each measurement.
- c) Set EUT at maximum average power by base station simulator.
- d) Measure lowest, middle, and highest channels for each bandwidth and different modulation.

Test For Effective Isotropic Radiated Power Measurement:

- a) The EUT was placed on a turntable with 1.5 meter height in a fully anechoic chamber.
- b) The EUT was set at 3 meters from the receiving antenna, which was mounted on the antenna tower
- c) LTE operating modes: use channel power function to test
- d) The table was rotated 360 degrees to determine the position of the highest radiated power.
- e) The height of the receiving antenna is adjusted to look for the maximum EIRP.
- f) The maximum EIRP shall be record.
- g) A dipole antenna was substituted in place of the EUT and was driven by a signal generator.
- h) The conducted power at the terminal of the dipole antenna is measured.
- i) Repeat step c) to step h) to get the maximum EIRP of the substitution antenna.
- j) $EIRP = P_s + E_t - E_s + G_s = P_s + R_t - R_s + G_s$.
- k) P_s (dBm): Input power to substitution antenna
- l) G_s (dBi or dBd): Substitution antenna Gain.
- m) $E_t = R_t + AF$
- n) $E_s = R_s + AF$
- o) AF (dB/m): Receive antenna factor
- p) R_t : The highest received signal in spectrum analyzer for EUT.
- q) R_s : The highest received signal in spectrum analyzer for substitution antenna.

3.4. Test Result

Product	Module	Test Site	AC-5
Test Item	Maximum Output Power	Date of Test	2017/03/29
Test Mode	Mode 1: LTE Band 2 Link	Test engineer	Scott

BW [MHz]	RB Size	RB Offset	Mod	Maximum Average Power[dBm]		
				Low Ch. / Freq.	Mid Ch. / Freq.	High Ch. / Freq.
Channel				18700	18900	19100
Frequency				1860	1880	1900
20	1	0	QPSK	23.05	22.59	22.89
20	1	49		22.61	22.93	23.19
20	1	99		22.49	22.45	23.18
20	50	0		21.81	21.75	21.96
20	50	24		21.76	21.82	21.85
20	50	49		21.70	21.89	21.87
20	100	0		21.71	21.83	21.81
20	1	0	16-QAM	22.18	22.48	22.20
20	1	49		22.24	22.66	22.17
20	1	99		22.14	22.36	22.27
20	50	0		21.48	21.39	21.48
20	50	24		21.44	21.37	21.45
20	50	49		21.43	21.42	21.38
20	100	0		21.43	21.41	21.37
Channel				18675	18900	19125
Frequency				1857.5	1880	1902.5
15	1	0	QPSK	22.63	22.67	22.87
15	1	37		22.65	22.61	22.99
15	1	74		22.51	22.71	22.94
15	36	0		21.81	21.71	21.89
15	36	18		21.77	21.82	21.87
15	36	37		21.75	21.85	21.91
15	75	0		21.77	21.66	21.79
15	1	0	16-QAM	22.21	22.08	22.26
15	1	37		22.18	22.10	22.37
15	1	74		22.06	22.28	22.29

15	36	0		21.36	21.28	21.42
15	36	18		21.39	21.37	21.48
15	36	37		21.25	21.41	21.51
15	75	0		21.24	21.23	21.40
Channel				18650	18900	19150
Frequency				1855	1880	1905
10	1	0	QPSK	23.07	23.04	23.17
10	1	24		23.23	22.98	23.11
10	1	49		22.93	23.18	23.07
10	25	0		21.98	21.91	21.96
10	25	12		22.02	21.96	21.99
10	25	24		22.03	22.00	22.15
10	50	0		22.01	22.07	22.01
10	1	0	16-QAM	22.36	22.32	23.03
10	1	24		22.25	22.03	22.64
10	1	49		22.31	22.21	22.34
10	25	0		21.61	21.41	21.49
10	25	12		21.67	21.53	21.78
10	25	24		21.61	21.48	21.84
10	50	0		21.36	21.49	21.54
Channel				18625	18900	19175
Frequency				1852.5	1880	1907.5
5	1	0	QPSK	23.04	22.88	23.07
5	1	12		23.11	22.84	23.34
5	1	24		23.00	22.87	22.99
5	12	0		22.02	21.93	22.04
5	12	6		22.12	22.02	22.16
5	12	11		22.15	22.09	22.33
5	25	0		22.03	21.97	22.19
5	1	0	16-QAM	22.02	21.90	22.61
5	1	12		22.27	22.15	23.05
5	1	24		21.99	22.42	23.06
5	12	0		21.31	21.27	21.49
5	12	6		21.35	21.33	21.59
5	12	11		21.29	21.26	21.65
5	25	0		21.43	21.33	21.66

Channel				18615	18900	19185
Frequency				1851.5	1880	1908.5
3	1	0	QPSK	23.23	23.28	23.83
3	1	7		23.27	23.09	23.63
3	1	14		23.31	23.28	23.94
3	8	0		22.31	22.24	22.64
3	8	4		22.36	22.33	22.69
3	8	7		22.47	22.38	22.78
3	15	0		22.38	22.24	22.71
3	1	0	16-QAM	22.94	22.98	23.39
3	1	7		22.92	22.88	23.25
3	1	14		23.17	22.94	23.28
3	8	0		21.94	21.98	22.39
3	8	4		21.97	22.04	22.42
3	8	7		22.09	22.12	22.43
3	15	0		22.02	22.06	22.37
Channel				18607	18900	19193
Frequency				1850.7	1880	1909.3
1.4	1	0	QPSK	22.78	23.05	22.96
1.4	1	2		22.92	22.82	23.11
1.4	1	5		23.01	23.02	23.36
1.4	3	0		22.73	22.71	23.02
1.4	3	1		22.87	22.75	23.21
1.4	3	2		22.92	22.95	23.29
1.4	6	0		21.91	21.79	22.03
1.4	1	0	16-QAM	21.72	21.93	21.87
1.4	1	2		22.12	21.88	22.31
1.4	1	5		21.82	21.88	21.98
1.4	3	0		21.93	21.66	22.20
1.4	3	1		21.87	21.67	22.21
1.4	3	2		21.83	21.69	22.19
1.4	6	0		20.83	20.67	21.06

Product	Module	Test Site	AC-5
Test Item	Maximum Output Power	Date of Test	2017/03/29
Test Mode	Mode 2: LTE Band 4 Link	Test engineer	Scott

BW [MHz]	RB Size	RB Offset	Mod	Maximum Average Power[dBm]		
				Low Ch. / Freq.	Mid Ch. / Freq.	High Ch. / Freq.
Channel				20050	20175	20300
Frequency				1720	1732.5	1745
20	1	0	QPSK	22.91	23.17	21.96
20	1	49		23.32	23.51	22.23
20	1	99		23.18	23.03	21.98
20	50	0		22.33	21.31	21.49
20	50	24		22.41	21.34	21.17
20	50	49		22.48	21.32	21.25
20	100	0		22.38	21.27	21.33
20	1	0	16-QAM	22.02	22.14	22.52
20	1	49		22.32	22.39	22.69
20	1	99		22.34	22.01	22.51
20	50	0		21.26	21.31	21.47
20	50	24		21.29	21.27	21.41
20	50	49		21.33	21.25	21.32
20	100	0		21.32	21.39	21.45
Channel				20025	20175	20325
Frequency				1717.5	1732.5	1747.5
15	1	0	QPSK	22.81	22.60	22.64
15	1	37		23.36	22.43	23.31
15	1	74		22.97	21.55	22.52
15	36	0		21.09	21.13	21.28
15	36	18		21.17	21.19	21.33
15	36	37		21.16	21.17	21.17
15	75	0		21.29	21.19	21.16
15	1	0	16-QAM	21.96	22.34	22.21
15	1	37		22.08	22.34	22.26
15	1	74		22.04	22.22	22.08
15	36	0		21.05	21.33	21.24
15	36	18		21.17	21.30	21.19

15	36	37		21.27	21.32	21.14
15	75	0		21.26	21.18	21.10
Channel				20000	20175	20350
Frequency				1715	1732.5	1750
10	1	0	QPSK	23.02	23.03	23.32
10	1	24		23.16	23.26	23.54
10	1	49		23.07	23.18	23.21
10	25	0		22.06	22.30	22.13
10	25	12		22.13	22.32	22.25
10	25	24		22.09	22.25	22.28
10	50	0		22.20	22.23	22.16
10	1	0	16-QAM	21.98	22.46	22.68
10	1	24		22.25	23.24	23.15
10	1	49		21.94	22.25	22.75
10	25	0		21.37	21.32	21.28
10	25	12		21.28	21.27	21.25
10	25	24		21.21	21.14	21.24
10	50	0		21.04	21.15	21.28
Channel				19975	20175	20375
Frequency				1712.5	1732.5	1752.5
5	1	0	QPSK	22.94	23.23	23.11
5	1	12		23.03	23.27	23.09
5	1	24		23.10	23.17	23.04
5	12	0		21.98	22.38	22.11
5	12	6		22.13	22.35	22.21
5	12	11		22.18	22.28	22.16
5	25	0		22.18	22.23	22.18
5	1	0	16-QAM	22.08	22.06	22.91
5	1	12		22.19	22.10	23.11
5	1	24		21.95	21.96	23.01
5	12	0		21.34	21.65	21.63
5	12	6		21.31	21.68	21.65
5	12	11		21.27	21.66	21.62
5	25	0		21.44	21.59	21.64
Channel				19965	20175	20385
Frequency				1711.5	1732.5	1753.5
3	1	0	QPSK	22.93	23.24	22.94

3	1	7		23.13	23.38	23.21
3	1	14		22.91	23.18	22.86
3	8	0		22.09	22.31	22.07
3	8	4		22.05	22.29	22.13
3	8	7		22.07	22.25	22.10
3	15	0		22.06	22.31	22.04
3	1	0		16-QAM	22.44	22.93
3	1	7	22.40		22.77	23.15
3	1	14	22.52		22.62	23.12
3	8	0	21.30		21.99	21.72
3	8	4	21.26		22.01	21.69
3	8	7	21.31		21.92	21.74
3	15	0	21.45		21.71	21.42
Channel				19957	20175	20393
Frequency				1710.7	1732.5	1754.3
1.4	1	0	QPSK	23.12	22.51	22.52
1.4	1	2		23.19	22.65	22.86
1.4	1	5		22.96	22.82	22.97
1.4	3	0		22.33	22.80	22.66
1.4	3	1		22.70	22.86	22.65
1.4	3	2		22.53	22.82	22.68
1.4	6	0		21.36	21.54	21.29
1.4	1	0	16-QAM	22.06	22.37	22.18
1.4	1	2		22.19	22.25	22.27
1.4	1	5		22.14	22.35	22.17
1.4	3	0		22.16	22.34	22.04
1.4	3	1		22.35	22.31	22.14
1.4	3	2		22.29	22.24	22.13
1.4	6	0		21.15	21.29	21.05

Product	Module	Test Site	AC-5
Test Item	Maximum Output Power	Date of Test	2017/03/29
Test Mode	Mode 3: LTE Band 5 Link	Test engineer	Scott

BW [MHz]	RB Size	RB Offset	Mod	Maximum Average Power[dBm]		
				Low Ch. / Freq.	Mid Ch. / Freq.	High Ch. / Freq.
Channel				20450	20525	20600
Frequency				829	836.5	844
10	1	0	QPSK	23.35	22.99	23.13
10	1	24		23.53	22.04	23.50
10	1	49		23.15	22.93	23.11
10	25	0		22.19	22.07	22.02
10	25	12		22.31	22.17	22.13
10	25	24		22.21	22.13	22.26
10	50	0		22.19	22.11	22.13
10	1	0	16-QAM	22.97	23.15	22.58
10	1	24		23.06	22.97	22.74
10	1	49		22.90	23.11	22.51
10	25	0		21.68	21.76	21.63
10	25	12		21.64	21.56	21.77
10	25	24		21.55	21.60	21.86
10	50	0		21.56	21.51	21.51
Channel				20425	20525	20625
Frequency				826.5	836.5	846.5
5	1	0	QPSK	23.22	22.94	22.83
5	1	12		23.38	22.92	23.15
5	1	24		23.27	23.01	23.18
5	12	0		22.26	22.17	22.17
5	12	6		22.31	22.14	22.25
5	12	11		22.33	22.13	22.21
5	25	0		22.32	22.08	22.11
5	1	0	16-QAM	22.45	22.58	22.52
5	1	12		22.51	22.73	22.86
5	1	24		22.91	22.83	22.55
5	12	0		21.97	21.93	21.98
5	12	6		22.03	22.03	22.01

5	12	11		22.04	21.94	21.93
5	25	0		22.14	22.12	22.02
Channel				20415	20525	20635
Frequency				825.5	836.5	847.5
3	1	0	QPSK	23.48	23.07	23.18
3	1	7		23.51	22.92	23.33
3	1	14		23.38	22.97	23.46
3	8	0		22.36	22.17	22.25
3	8	4		22.42	22.13	22.27
3	8	7		22.38	22.07	22.17
3	15	0		22.34	22.14	22.16
3	1	0		16-QAM	23.43	23.26
3	1	7	22.83		22.70	22.94
3	1	14	23.17		22.41	21.94
3	8	0	22.52		21.82	22.08
3	8	4	22.45		21.85	21.84
3	8	7	22.51		21.81	21.69
3	15	0	22.17		21.79	22.01
Channel					20407	20525
Frequency				824.7	836.5	848.3
1.4	1	0	QPSK	23.27	23.35	23.26
1.4	1	2		23.29	23.39	23.17
1.4	1	5		23.27	23.28	23.11
1.4	3	0		23.48	23.36	23.14
1.4	3	1		23.45	23.13	23.27
1.4	3	2		23.38	22.96	23.41
1.4	6	0		22.27	22.04	22.15
1.4	1	0	16-QAM	23.11	23.47	23.35
1.4	1	2		23.47	23.58	23.42
1.4	1	5		22.89	22.88	23.34
1.4	3	0		23.16	22.76	23.19
1.4	3	1		23.23	22.81	23.15
1.4	3	2		23.52	22.89	23.22
1.4	6	0		21.68	21.82	22.06

Product	Module	Test Site	AC-5
Test Item	Maximum Output Power	Date of Test	2017/03/29
Test Mode	Mode 4: LTE Band 7 Link	Test engineer	Scott

BW [MHz]	RB Size	RB Offset	Mod	Maximum Average Power[dBm]		
				Low Ch. / Freq.	Mid Ch. / Freq.	High Ch. / Freq.
Channel				20850	21100	21350
Frequency				2510	2535	2560
20	1	0	QPSK	22.89	23.09	22.96
20	1	49		23.03	23.23	23.33
20	1	99		22.98	22.76	23.11
20	50	0		22.32	22.16	21.92
20	50	24		22.15	22.13	21.94
20	50	49		22.24	22.05	21.95
20	100	0		22.34	21.99	21.99
20	1	0	16-QAM	22.41	22.14	21.61
20	1	49		22.51	22.48	22.11
20	1	99		22.37	22.32	21.74
20	50	0		20.75	20.83	20.81
20	50	24		20.67	20.89	20.62
20	50	49		20.66	20.91	20.72
20	100	0		20.75	20.82	20.79
Channel				20825	21100	21375
Frequency				2507.5	2535	2562.5
15	1	0	QPSK	23.43	23.37	23.05
15	1	37		23.45	23.33	23.08
15	1	74		23.33	23.25	22.99
15	36	0		22.33	22.24	21.98
15	36	18		22.27	22.17	22.01
15	36	37		22.11	22.03	22.02
15	75	0		22.15	22.05	22.26
15	1	0	16-QAM	23.25	23.16	23.03
15	1	37		23.23	23.25	23.01
15	1	74		23.18	23.11	22.52
15	36	0		22.19	22.09	21.97
15	36	18		22.21	22.11	21.81

15	36	37		22.12	22.03	22.09
15	75	0		22.17	22.05	21.81
Channel				20800	21100	21400
Frequency				2505	2535	2565
10	1	0	QPSK	23.07	23.16	23.01
10	1	24		23.52	23.31	22.94
10	1	49		23.38	23.08	23.04
10	25	0		22.11	22.03	22.24
10	25	12		22.09	22.02	22.17
10	25	24		22.12	21.97	22.11
10	50	0		22.06	22.02	22.01
10	1	0	16-QAM	23.07	23.37	23.54
10	1	24		23.08	23.61	23.03
10	1	49		22.80	23.13	22.81
10	25	0		22.47	21.86	21.97
10	25	12		22.05	22.12	22.05
10	25	24		22.28	21.96	21.87
10	50	0		22.22	21.99	22.04
Channel				20775	21100	21425
Frequency				2502.5	2535	2567.5
5	1	0	QPSK	23.22	22.97	22.82
5	1	12		23.26	23.07	22.97
5	1	24		22.97	22.85	22.77
5	12	0		22.15	22.11	21.97
5	12	6		22.11	22.13	22.07
5	12	11		22.07	21.99	22.06
5	25	0		23.22	22.97	22.82
5	1	0	16-QAM	22.69	22.23	22.17
5	1	12		22.72	22.56	22.34
5	1	24		22.58	22.45	22.33
5	12	0		21.69	21.39	21.21
5	12	6		21.71	21.29	21.36
5	12	11		21.65	21.34	21.28
5	25	0		21.66	21.25	21.29

Product	Module	Test Site	AC-5
Test Item	Maximum Output Power	Date of Test	2017/03/29
Test Mode	Mode 5: LTE Band 12 Link	Test engineer	Scott

BW [MHz]	RB Size	RB Offset	Mod	Maximum Average Power[dBm]		
				Low Ch. / Freq.	Mid Ch. / Freq.	High Ch. / Freq.
Channel				23060	23095	23130
Frequency				704	707.5	711
10	1	0	QPSK	22.68	23.16	23.54
10	1	24		23.23	23.61	24.06
10	1	49		22.98	23.14	23.63
10	25	0		21.95	22.09	22.31
10	25	12		22.09	22.18	22.24
10	25	24		22.14	22.25	22.03
10	50	0		21.88	22.14	22.17
10	1	0	16-QAM	22.93	23.08	23.21
10	1	24		23.27	23.11	23.28
10	1	49		23.05	22.89	22.89
10	25	0		22.07	22.21	22.23
10	25	12		22.13	22.17	22.13
10	25	24		22.26	22.03	21.96
10	50	0		22.18	22.11	22.09
Channel				23035	23095	23155
Frequency				701.5	707.5	713.5
5	1	0	QPSK	22.71	22.96	23.01
5	1	12		23.05	23.04	22.81
5	1	24		22.72	22.96	22.82
5	12	0		22.02	22.17	21.97
5	12	6		21.93	22.13	22.01
5	12	11		22.11	21.99	22.02
5	25	0		22.03	22.08	21.94
5	1	0	16-QAM	22.59	22.63	22.58
5	1	12		22.73	22.75	22.75
5	1	24		22.71	22.79	22.66
5	12	0		21.90	21.88	22.01
5	12	6		21.89	22.12	21.79

5	12	11		21.75	22.17	21.64
5	25	0		22.09	22.04	21.75
Channel				23025	23095	23165
Frequency				700.5	707.5	714.5
3	1	0	QPSK	22.97	23.33	23.16
3	1	7		23.18	23.36	23.31
3	1	14		23.03	23.25	23.23
3	8	0		22.15	22.31	22.24
3	8	4		22.21	22.34	22.18
3	8	7		22.08	22.27	22.21
3	15	0		22.06	22.21	22.26
3	1	0		16-QAM	22.87	23.09
3	1	7	23.05		23.03	22.97
3	1	14	22.91		23.04	22.92
3	8	0	22.07		22.24	22.09
3	8	4	22.12		22.21	22.07
3	8	7	22.08		22.11	22.11
3	15	0	22.02		22.19	22.04
Channel					23017	23095
Frequency				699.7	707.5	715.3
1.4	1	0	QPSK	23.48	23.37	23.34
1.4	1	2		23.25	23.26	23.49
1.4	1	5		23.37	23.29	23.32
1.4	3	0		23.03	23.11	23.02
1.4	3	1		23.10	23.12	23.06
1.4	3	2		22.98	23.05	23.14
1.4	6	0		21.77	21.72	21.96
1.4	1	0	16-QAM	22.97	23.40	23.15
1.4	1	2		23.04	23.21	23.06
1.4	1	5		23.02	23.32	22.97
1.4	3	0		22.97	23.06	23.14
1.4	3	1		23.01	23.02	23.07
1.4	3	2		23.04	23.05	23.02
1.4	6	0		21.99	22.09	21.98

Product	Module	Test Site	AC-5
Test Item	Maximum Output Power	Date of Test	2017/03/29
Test Mode	Mode 6: LTE Band 13 Link	Test engineer	Scott

BW [MHz]	RB Size	RB Offset	Mod	Maximum Average Power[dBm]		
				Low Ch. / Freq.	Mid Ch. / Freq.	High Ch. / Freq.
Channel				/	23230	/
Frequency				/	782	/
10	1	0	QPSK	/	23.12	/
10	1	24		/	23.99	/
10	1	49		/	23.43	/
10	25	0		/	22.23	/
10	25	12		/	22.26	/
10	25	24		/	22.29	/
10	50	0		/	22.05	/
10	1	0	16-QAM	/	22.94	/
10	1	24		/	23.31	/
10	1	49		/	23.23	/
10	25	0		/	22.26	/
10	25	12		/	22.27	/
10	25	24		/	22.19	/
10	50	0		/	22.22	/
Channel				23205	23230	23255
Frequency				779.5	782	784.5
5	1	0	QPSK	23.09	23.13	23.29
5	1	12		23.18	23.29	23.31
5	1	24		23.12	23.19	22.89
5	12	0		22.23	22.11	22.29
5	12	6		22.21	22.21	22.33
5	12	11		22.13	22.25	22.30
5	25	0		22.11	22.14	22.39
5	1	0	16-QAM	22.35	22.29	22.69
5	1	12		22.65	22.19	22.84
5	1	24		22.63	22.32	22.77
5	12	0		21.64	21.50	21.65
5	12	6		21.69	21.48	21.56
5	12	11		21.58	21.53	21.71
5	25	0		21.61	21.81	21.78

Product	Module	Test Site	AC-5
Test Item	Maximum Output Power	Date of Test	2017/03/29
Test Mode	Mode 7: LTE Band 17 Link	Test engineer	Scott

BW [MHz]	RB Size	RB Offset	Mod	Maximum Average Power[dBm]		
				Low Ch. / Freq.	Mid Ch. / Freq.	High Ch. / Freq.
Channel				23780	23790	23800
Frequency				709	710	711
10	1	0	QPSK	22.96	23.01	23.02
10	1	24		22.91	23.07	23.37
10	1	49		22.96	22.83	22.89
10	25	0		22.09	22.03	22.02
10	25	12		22.12	22.05	22.07
10	25	24		22.08	22.07	22.05
10	50	0		22.17	22.08	22.00
10	1	0	16-QAM	22.36	22.47	23.02
10	1	24		22.43	22.53	23.08
10	1	49		22.47	22.46	22.89
10	25	0		22.02	22.11	21.86
10	25	12		22.06	22.07	21.71
10	25	24		22.10	22.09	21.83
10	50	0		22.09	22.12	21.77
Channel				23755	23790	23825
Frequency				706.5	710	713.5
5	1	0	QPSK	23.48	23.39	23.35
5	1	12		23.53	23.36	23.43
5	1	24		23.43	23.35	23.17
5	12	0		22.03	22.13	22.01
5	12	6		22.09	22.07	22.07
5	12	11		22.11	21.96	22.05
5	25	0		21.99	22.01	21.99
5	1	0	16-QAM	23.13	22.63	22.84
5	1	12		23.22	22.72	22.80
5	1	24		23.35	22.69	22.63
5	12	0		21.85	21.85	21.77
5	12	6		21.97	21.93	21.79
5	12	11		21.85	21.86	21.89
5	25	0		21.93	21.83	22.05

Product	Module	Test Site	AC-5
Test Item	Effective Isotropic Radiated Power	Date of Test	2017/03/29
Test Mode	Mode 1: LTE Band 2 Link	Test engineer	Scott

LTE Band	Channel BW (MHz)	Modulation	RB Configuration		Channel	Freq. (MHz)	EIRP (dBm)
			RB Size	RB Offset			
2	20	QPSK	1	0	Low	1860	24.07
2	20	QPSK	1	0	Mid	1880	24.33
2	20	QPSK	1	0	High	1900	24.21
2	20	16QAM	1	0	Low	1860	23.61
2	20	16QAM	1	0	Mid	1880	23.83
2	20	16QAM	1	0	High	1900	23.37
2	15	QPSK	1	0	Low	1857.5	24.06
2	15	QPSK	1	0	Mid	1880.0	24.18
2	15	QPSK	1	0	High	1902.5	23.95
2	15	16QAM	1	0	Low	1857.5	23.43
2	15	16QAM	1	0	Mid	1880.0	23.39
2	15	16QAM	1	0	High	1902.5	23.41
2	10	QPSK	1	0	Low	1855	24.31
2	10	QPSK	1	0	Mid	1880	24.30
2	10	QPSK	1	0	High	1905	24.14
2	10	16QAM	1	0	Low	1855	24.05
2	10	16QAM	1	0	Mid	1880	23.76
2	10	16QAM	1	0	High	1905	23.38
2	5	QPSK	1	0	Low	1852.5	24.07
2	5	QPSK	1	0	Mid	1880	24.47
2	5	QPSK	1	0	High	1907.5	24.05
2	5	16QAM	1	0	Low	1852.5	23.76
2	5	16QAM	1	0	Mid	1880	24.24
2	5	16QAM	1	0	High	1907.5	24.17
2	3	QPSK	1	0	Low	1851.5	24.85
2	3	QPSK	1	0	Mid	1880	24.74
2	3	QPSK	1	0	High	1908.5	25.07
2	3	16QAM	1	0	Low	1851.5	24.56
2	3	16QAM	1	0	Mid	1880	24.40
2	3	16QAM	1	0	High	1908.5	24.29

2	1.4	QPSK	1	0	Low	1850.7	24.13
2	1.4	QPSK	1	0	Mid	1880	23.90
2	1.4	QPSK	1	0	High	1909.3	24.12
2	1.4	16QAM	1	0	Low	1850.7	23.04
2	1.4	16QAM	1	0	Mid	1880	22.92
2	1.4	16QAM	1	0	High	1909.3	22.95

Note: For EIRP test, we have evaluated all the and RB size and Offset in each channel, we choose the worst data shown in the report.

Product	Module	Test Site	AC-5
Test Item	Effective Isotropic Radiated Power	Date of Test	2017/03/29
Test Mode	Mode 2: LTE Band 4 Link	Test engineer	Scott

LTE Band	Channel BW (MHz)	Modulation	RB Configuration		Channel	Freq. (MHz)	EIRP (dBm)
			RB Size	RB Offset			
4	20	QPSK	1	0	Low	1720.0	24.22
4	20	QPSK	1	0	Mid	1723.5	24.44
4	20	QPSK	1	0	High	1745.0	23.36
4	20	16QAM	1	0	Low	1720.0	23.40
4	20	16QAM	1	0	Mid	1723.5	23.25
4	20	16QAM	1	0	High	1745.0	23.74
4	15	QPSK	1	0	Low	1717.5	24.54
4	15	QPSK	1	0	Mid	1732.5	23.59
4	15	QPSK	1	0	High	1747.5	24.34
4	15	16QAM	1	0	Low	1717.5	22.89
4	15	16QAM	1	0	Mid	1732.5	23.51
4	15	16QAM	1	0	High	1747.5	23.23
4	10	QPSK	1	0	Low	1715	24.36
4	10	QPSK	1	0	Mid	1732.5	24.26
4	10	QPSK	1	0	High	1750	24.65
4	10	16QAM	1	0	Low	1715	23.08
4	10	16QAM	1	0	Mid	1732.5	24.14
4	10	16QAM	1	0	High	1750	24.05
4	5	QPSK	1	0	Low	1712.5	24.21
4	5	QPSK	1	0	Mid	1732.5	24.13
4	5	QPSK	1	0	High	1752.5	24.04
4	5	16QAM	1	0	Low	1712.5	23.16
4	5	16QAM	1	0	Mid	1732.5	23.02
4	5	16QAM	1	0	High	1752.5	24.17
4	3	QPSK	1	0	Low	1711.5	24.23
4	3	QPSK	1	0	Mid	1732.5	24.26
4	3	QPSK	1	0	High	1753.5	24.09
4	3	16QAM	1	0	Low	1711.5	23.41
4	3	16QAM	1	0	Mid	1732.5	23.46
4	3	16QAM	1	0	High	1753.5	24.04

4	1.4	QPSK	1	0	Low	1710.7	24.14
4	1.4	QPSK	1	0	Mid	1732.5	23.74
4	1.4	QPSK	1	0	High	1754.3	24.00
4	1.4	16QAM	1	0	Low	1710.7	23.18
4	1.4	16QAM	1	0	Mid	1732.5	23.19
4	1.4	16QAM	1	0	High	1754.3	23.27

Note: For EIRP test, we have evaluated all the and RB size and Offset in each channel, we choose the worst data shown in the report.

Product	Module	Test Site	AC-5
Test Item	Effective Isotropic Radiated Power	Date of Test	2017/03/29
Test Mode	Mode 3: LTE Band 5 Link	Test engineer	Scott

LTE Band	Channel BW (MHz)	Modulation	RB Configuration		Channel	Freq. (MHz)	ERP (dBm)
			RB Size	RB Offset			
5	10	QPSK	1	0	Low	829	24.53
5	10	QPSK	1	0	Mid	836.5	23.87
5	10	QPSK	1	0	High	844	24.46
5	10	16QAM	1	0	Low	829	23.89
5	10	16QAM	1	0	Mid	836.5	23.93
5	10	16QAM	1	0	High	844	23.70
5	5	QPSK	1	0	Low	826.5	24.45
5	5	QPSK	1	0	Mid	836.5	23.86
5	5	QPSK	1	0	High	846.5	24.15
5	5	16QAM	1	0	Low	826.5	23.80
5	5	16QAM	1	0	Mid	836.5	23.91
5	5	16QAM	1	0	High	846.5	23.67
5	3	QPSK	1	0	Low	825.5	24.53
5	3	QPSK	1	0	Mid	836.5	24.01
5	3	QPSK	1	0	High	847.5	24.38
5	3	16QAM	1	0	Low	825.5	23.98
5	3	16QAM	1	0	Mid	836.5	23.58
5	3	16QAM	1	0	High	847.5	23.81
5	1.4	QPSK	1	0	Low	824.7	24.31
5	1.4	QPSK	1	0	Mid	836.5	24.51
5	1.4	QPSK	1	0	High	848.3	24.36
5	1.4	16QAM	1	0	Low	824.7	24.48
5	1.4	16QAM	1	0	Mid	836.5	24.67
5	1.4	16QAM	1	0	High	848.3	24.49

Note: For EIRP test, we have evaluated all the and RB size and Offset in each channel, we choose the worst data shown in the report.

Product	Module	Test Site	AC-5
Test Item	Effective Isotropic Radiated Power	Date of Test	2017/03/29
Test Mode	Mode 4: LTE Band 7 Link	Test engineer	Scott

LTE Band	Channel BW (MHz)	Modulation	RB Configuration		Channel	Freq. (MHz)	EIRP (dBm)
			RB Size	RB Offset			
7	20	QPSK	1	0	Low	2510	24.19
7	20	QPSK	1	0	Mid	2535	24.15
7	20	QPSK	1	0	High	2560	24.27
7	20	16QAM	1	0	Low	2510	23.39
7	20	16QAM	1	0	Mid	2535	23.56
7	20	16QAM	1	0	High	2560	23.07
7	15	QPSK	1	0	Low	2507.5	24.62
7	15	QPSK	1	0	Mid	2535	24.25
7	15	QPSK	1	0	High	2562.5	24.20
7	15	16QAM	1	0	Low	2507.5	24.29
7	15	16QAM	1	0	Mid	2535	24.35
7	15	16QAM	1	0	High	2562.5	24.42
7	10	QPSK	1	0	Low	2505	24.60
7	10	QPSK	1	0	Mid	2535	24.29
7	10	QPSK	1	0	High	2565	24.00
7	10	16QAM	1	0	Low	2505	23.93
7	10	16QAM	1	0	Mid	2535	24.14
7	10	16QAM	1	0	High	2565	24.26
7	5	QPSK	1	0	Low	2502.5	24.37
7	5	QPSK	1	0	Mid	2535	24.03
7	5	QPSK	1	0	High	2567.5	24.02
7	5	16QAM	1	0	Low	2502.5	23.80
7	5	16QAM	1	0	Mid	2535	23.59
7	5	16QAM	1	0	High	2567.5	23.30

Note: For EIRP test, we have evaluated all the and RB size and Offset in each channel, we choose the worst data shown in the report.

Product	Module	Test Site	AC-5
Test Item	Effective Isotropic Radiated Power	Date of Test	2017/03/29
Test Mode	Mode 5: LTE Band 12 Link	Test engineer	Scott

LTE Band	Channel BW (MHz)	Modulation	RB Configuration		Channel	Freq. (MHz)	ERP (dBm)
			RB Size	RB Offset			
12	10	QPSK	1	0	Low	704	24.30
12	10	QPSK	1	0	Mid	707.5	24.72
12	10	QPSK	1	0	High	711	24.94
12	10	16QAM	1	0	Low	704	24.20
12	10	16QAM	1	0	Mid	707.5	24.01
12	10	16QAM	1	0	High	711	24.30
12	5	QPSK	1	0	Low	701.5	23.90
12	5	QPSK	1	0	Mid	707.5	24.13
12	5	QPSK	1	0	High	713.5	23.64
12	5	16QAM	1	0	Low	701.5	23.70
12	5	16QAM	1	0	Mid	707.5	23.71
12	5	16QAM	1	0	High	713.5	23.74
12	3	QPSK	1	0	Low	700.5	24.29
12	3	QPSK	1	0	Mid	707.5	24.41
12	3	QPSK	1	0	High	714.5	24.25
12	3	16QAM	1	0	Low	700.5	23.93
12	3	16QAM	1	0	Mid	707.5	24.16
12	3	16QAM	1	0	High	714.5	24.16
12	1.4	QPSK	1	0	Low	699.7	24.28
12	1.4	QPSK	1	0	Mid	707.5	24.17
12	1.4	QPSK	1	0	High	715.3	24.25
12	1.4	16QAM	1	0	Low	699.7	24.09
12	1.4	16QAM	1	0	Mid	707.5	24.14
12	1.4	16QAM	1	0	High	715.3	23.97

Note: For EIRP test, we have evaluated all the and RB size and Offset in each channel, we choose the worst data shown in the report.

Product	Module	Test Site	AC-5
Test Item	Effective Isotropic Radiated Power	Date of Test	2017/03/29
Test Mode	Mode 6: LTE Band 13 Link	Test engineer	Scott

LTE Band	Channel BW (MHz)	Modulation	RB Configuration		Channel	Freq. (MHz)	ERP (dBm)
			RB Size	RB Offset			
13	10	QPSK	1	0	Mid	23230	24.89
13	10	16QAM	1	0	Mid	23230	24.26
13	5	QPSK	1	12	Low	779.5	24.22
13	5	QPSK	1	12	Mid	782	24.49
13	5	QPSK	1	12	High	784.5	24.43
13	5	16QAM	1	12	Low	779.5	23.72
13	5	16QAM	1	12	Mid	782	23.23
13	5	16QAM	1	12	High	784.5	24.00

Note: For EIRP test, we have evaluated all the and RB size and Offset in each channel, we choose the worst data shown in the report.

Product	Module	Test Site	AC-5
Test Item	Effective Isotropic Radiated Power	Date of Test	2017/03/29
Test Mode	Mode 7: LTE Band 17 Link	Test engineer	Scott

LTE Band	Channel BW (MHz)	Modulation	RB Configuration		Channel	Freq. (MHz)	ERP (dBm)
			RB Size	RB Offset			
17	10	QPSK	1	0	Low	709	23.87
17	10	QPSK	1	0	Mid	710	24.02
17	10	QPSK	1	0	High	711	24.34
17	10	16QAM	1	0	Low	709	23.54
17	10	16QAM	1	0	Mid	710	23.35
17	10	16QAM	1	0	High	711	24.19
17	5	QPSK	1	0	Low	706.5	24.49
17	5	QPSK	1	0	Mid	710	24.32
17	5	QPSK	1	0	High	713.5	24.27
17	5	16QAM	1	0	Low	706.5	24.34
17	5	16QAM	1	0	Mid	710	23.68
17	5	16QAM	1	0	High	713.5	23.76

Note: For EIRP test, we have evaluated all the and RB size and Offset in each channel, we choose the worst data shown in the report.

4. Peak-to-average power ratio

4.1. Test Equipment

Peak-to-average power ratio / AC-5				
Instrument	Manufacturer	Type No.	Serial No	Cali. Due Date
PSA Series Spectrum Analyzer	Agilent	E4440A	MY49420184	2018.02.04
Radio Communication Tester	Anritsu	MT8820C	6201181503	2017.09.16
Dual Directional Coupler	Agilent	778D	20160	2018.02.04
10dB Coaxial Coupler	Agilent	87300C	MY44300299	2018.03.28
Temperature/Humidity Meter	Zhicheng	ZC1-2	AC6-TH	2018.01.05

4.2. Test Setup

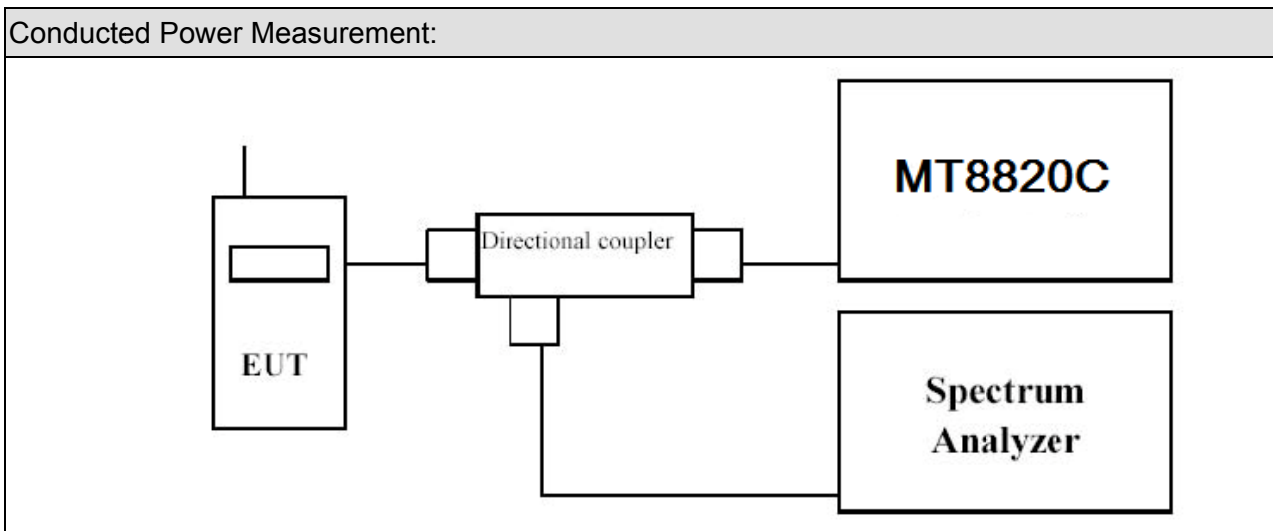

4.3. Test Procedure

<input checked="" type="checkbox"/>	CCDF procedure for PAPR
	<p>The inherent randomness of the power peaks in a noise-like digital signal makes it difficult to quantify the peak power using traditional measurement techniques for determining the peak power of an analog signal.</p> <p>The peak power of a digitally-modulated signal is predictable only on a statistical basis. Thus, for these types of signals, a statistical measurement of the peak power is necessary.</p> <p>The power complementary cumulative distribution function (CCDF) curves provide a means for characterizing the power peaks of a digitally modulated signal on a statistical basis. A CCDF curve depicts the probability of the peak signal amplitude exceeding the average power level. Most contemporary measurement instrumentation include the capability to produce CCDF curves for an input signal provided that the instrument's resolution bandwidth can be set wide enough to accommodate the entire input signal bandwidth. The following guidelines are offered for performing a CCDF measurement.</p> <ol style="list-style-type: none"> a) Refer to instrument's analyzer instruction manual for details on how to use the power statistics/CCDF function; b) Set resolution/measurement bandwidth \geq signal's occupied bandwidth; c) Set the number of counts to a value that stabilizes the measured CCDF curve; d) Set the measurement interval as follows: <ol style="list-style-type: none"> 1) for continuous transmissions, set to 1 ms, 2) for burst transmissions, employ an external trigger that is synchronized with the EUT burst timing sequence, or use the internal burst trigger with a trigger level that allows the burst to stabilize and set the measurement interval to a time that is less than or equal to the burst duration.

e) Record the maximum PAPR level associated with a probability of 0.1%.

Alternate procedure for PAPR

Use one of the procedures presented in 4.1 to measure the total peak power and record as PPk. Use one of the applicable procedures presented 4.2 to measure the total average power and record as PAvg. Both the peak and average power levels must be expressed in the same logarithmic units (e.g., dBm). Determine the PAPR from:

$$\text{PAPR (dB)} = \text{PPk (dBm)} - \text{PAvg (dBm)}.$$

4.4. Test Result

Product	Module	Test Site	TR-8
Test Item	Peak-to-average power ratio	Date of Test	2017/03/29
Test Mode	Mode 1: LTE Band 2 Link	Test engineer	Scott

BW [MHz]	RB Size	RB Offset	Mod	Maximum Average Power[dBm]		
				Low Ch. / Freq.	Mid Ch. / Freq.	High Ch. / Freq.
Channel				18700	18900	19100
Frequency				1860	1880	1900
20	100	0	QPSK	5.44	5.50	5.66
20	100	0	16-QAM	6.20	6.41	6.24
Channel				18675	18900	19125
Frequency				1857.5	1880	1902.5
15	75	0	QPSK	5.24	5.50	5.58
15	75	0	16-QAM	6.09	6.37	6.24
Channel				18650	18900	19150
Frequency				1855	1880	1905
10	50	0	QPSK	5.17	5.49	5.42
10	50	0	16-QAM	5.98	6.21	6.47
Channel				18625	18900	19175
Frequency				1852.5	1880	1907.5
5	25	0	QPSK	5.25	5.43	5.34
5	25	0	16-QAM	6.11	6.37	6.11
Channel				18615	18900	19185
Frequency				1851.5	1880	1908.5
3	15	0	QPSK	5.36	5.46	5.37
3	15	0	16-QAM	6.13	6.24	6.43
Channel				18607	18900	19193
Frequency				1850.7	1880	1909.3
1.4	6	0	QPSK	5.26	5.40	5.35
1.4	6	0	16-QAM	6.35	6.26	6.41

Note1: The worst case as below:

16QAM LTE Band 2 BW10M Channel 19100 100RB0

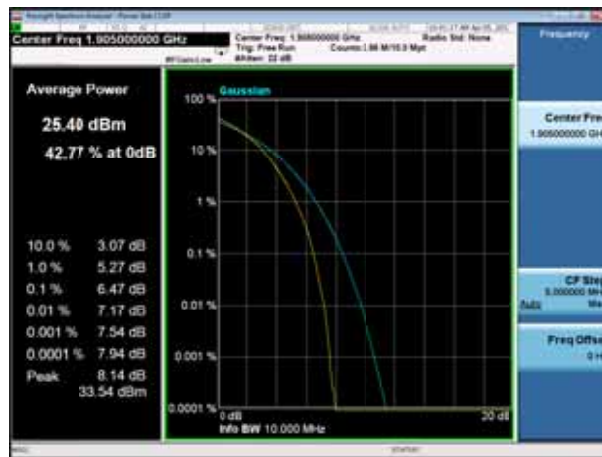

Product	Module	Test Site	TR-8
Test Item	Peak-to-average power ratio	Date of Test	2017/03/29
Test Mode	Mode 2: LTE Band 4 Link	Test engineer	Scott

BW [MHz]	RB Size	RB Offset	Mod	Maximum Average Power[dBm]		
				Low Ch. / Freq.	Mid Ch. / Freq.	High Ch. / Freq.
Channel				20050	20175	20300
Frequency				1720	1732.5	1745
20	100	0	QPSK	5.79	5.41	5.17
20	100	0	16-QAM	6.49	6.50	6.31
Channel				20025	20175	20325
Frequency				1717.5	1732.5	1747.5
15	75	0	QPSK	5.57	5.45	5.03
15	75	0	16-QAM	6.31	6.51	6.02
Channel				20000	20175	20350
Frequency				1715	1732.5	1750
10	50	0	QPSK	5.55	5.48	5.27
10	50	0	16-QAM	6.24	6.51	6.10
Channel				19975	20175	20375
Frequency				1712.5	1732.5	1752.5
5	25	0	QPSK	5.72	5.47	5.43
5	25	0	16-QAM	6.46	6.25	6.14
Channel				19965	20175	20385
Frequency				1711.5	1732.5	1753.5
3	15	0	QPSK	5.53	5.50	5.43
3	15	0	16-QAM	6.33	6.30	6.20
Channel				19957	20175	20393
Frequency				1710.7	1732.5	1754.3
1.4	6	0	QPSK	5.55	5.45	5.37
1.4	6	0	16-QAM	6.54	6.28	6.15

Note1: The worst case as below:

16QAM LTE Band 4 BW1.4M Channel 19957 6RB0

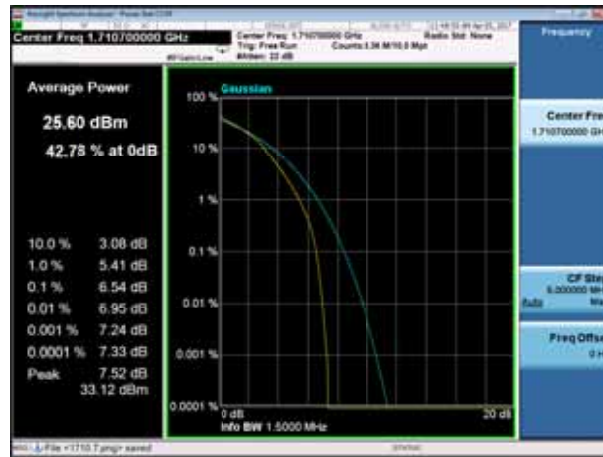

5. Occupied Bandwidth

5.1. Test Equipment

Occupied Bandwidth / TR-8				
Instrument	Manufacturer	Type No.	Serial No	Cali. Due Date
PSA Series Spectrum Analyzer	Agilent	E4440A	MY49420184	2018.02.04
Radio Communication Tester	Anritsu	MT8820C	6201181503	2017.09.16
Dual Directional Coupler	Agilent	778D	20160	2018.02.04
10dB Coaxial Coupler	Agilent	87300C	MY44300299	2018.03.28
Temperature/Humidity Meter	Zhicheng	ZC1-2	AC6-TH	2018.01.05

5.2. Test Setup

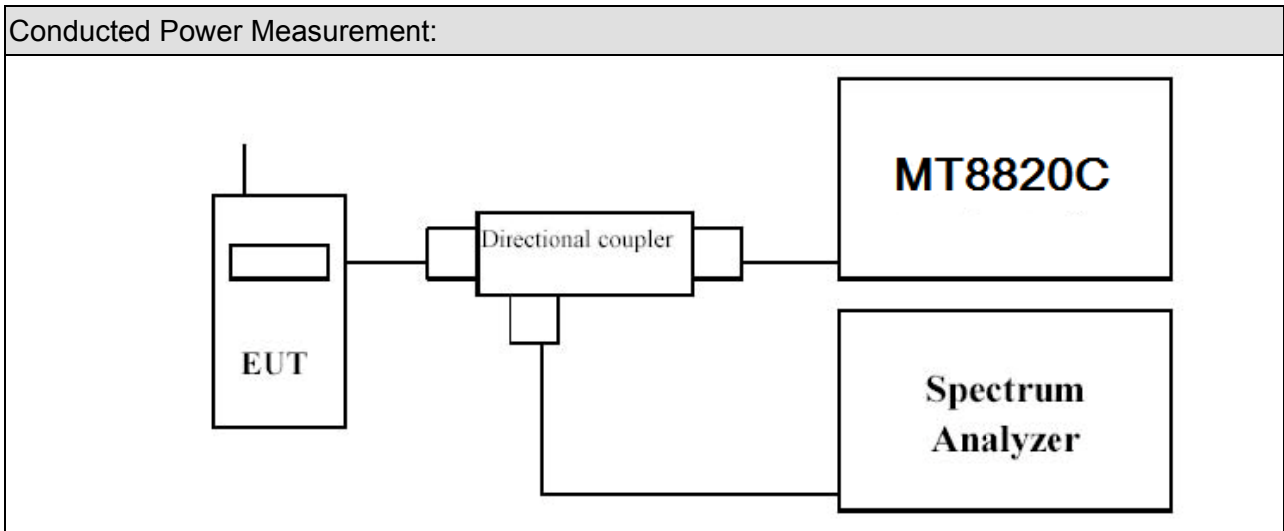

5.3. Test Procedure

Test Method for conducted test
<ol style="list-style-type: none"> 1. The EUT was connected to Spectrum Analyzer and Base Station via power divider. 2. The RF output of EUT was connected to the spectrum analyzer by RF cable and attenuator. The path loss was compensated to the results for each measurement. 3. The 99% occupied bandwidth and 26 dB bandwidth of the middle channel for the highest RF powers were measured.

5.4. Test Result

Product	Module	Test Site	AC-5
Test Item	Occupied Bandwidth	Date of Test	2017/03/29
Test Mode	Mode 1-7(QPSK)	Test engineer	Scott

Mode	Bandwidth (MHz)	Channel No.	Frequency (MHz)	99% Occupied Bandwidth (kHz)	-26dB Occupied Bandwidth (kHz)
LTE Band 2	20	18700	1860	17787	18970
		18900	1880	17834	19280
		19100	1900	17845	19120
	15	18675	1857.5	13375	14410
		18900	1880	13388	14300
		19125	1902.5	13383	14390
	10	18650	1855	8912.9	9547
		18900	1880	8923.1	9522
		19150	1905	8921.5	9461
	5	18625	1852.5	4467.0	4927
		18900	1880	4467.2	4855
		19175	1907.5	4478.8	4911
	3	18615	1851.5	2681.0	2913
		18900	1880	2678.7	2928
		19185	1908.5	2680.6	2908
	1.4	18607	1850.7	1076.9	1243
		18900	1880	1079.4	1261
		19193	1909.3	1079.1	1234
LTE Band 4	20	20050	1720	17834	19060
		20175	1732.5	17791	19030
		20300	1745	17872	19050
	15	20025	1717.5	13367	14230
		20175	1732.5	13381	14380
		20325	1747.5	13385	14320
	10	20000	1715	8933.3	9600
		20175	1732.5	8914.6	9626
		20350	1750	8937.4	9636
	5	19975	1712.5	4469.5	4956
		20175	1732.5	4460.3	4901

	3	20375	1752.5	4471.2	4893
		19965	1711.5	2679.6	2938
		20175	1732.5	2678.6	2928
	1.4	20385	1753.5	2682.6	2924
		19957	1710.7	1081.8	1265
		20175	1732.5	1078.3	1209
		20393	1754.3	1077.7	1229
LTE Band 5	10	20450	829	8923.3	9693
		20525	836.5	8923.6	9644
		20600	844	8938.6	9636
	5	20425	826.5	4463.7	4906
		20525	836.5	4466.8	4897
		20625	846.5	4460.8	4858
	3	20415	825.5	2682.9	2920
		20525	836.5	2683.1	2924
		20635	847.5	2689.2	2925
	1.4	20407	824.7	1083.8	1237
		20525	836.5	1077.6	1242
		20643	848.3	1078.7	1254
LTE Band 7	20	20850	2510	17875	19200
		21100	2535	17810	18880
		21350	2560	17807	19100
	15	20825	2507.5	13386	14340
		21100	2535	13374	14280
		21400	2562.5	13402	14350
	10	20800	2505	8916.3	9647
		21100	2535	8923.6	9704
		21400	2565	8917.2	9540
	5	20775	2502.5	4464.3	4933
		21100	2535	4459.7	4897
		21425	2567.5	4470.1	4900
LTE Band 12	10	23060	704	8916.2	9644
		23095	707.5	8918.6	9672
		23130	711	8928.6	9675
	5	23035	701.5	4473.5	4872
		23095	707.5	4455.5	4914
		23155	713.5	4474.1	4915

	3	23025	700.5	2687.6	2904
		23095	707.5	2682.1	2921
		23165	714.5	2680.3	2902
	1.4	23017	699.7	1079.1	1259
		23095	707.5	1077.3	1234
		23173	715.3	1075.2	1260
LTE Band 13	10	23230	782	8895.6	9664
	5	23205	779.5	4464.1	4864
		23230	782	4462.6	4909
		23255	784.5	4455	4874
LTE Band 17	10	23780	709	8920.2	9643
		23790	710	8941.2	9747
		23800	711	8936.6	9636
	5	23755	706.5	4463.8	4859
		23790	710	4462.1	4893
		23825	713.5	4469	4893

Note1: The worst case as below:

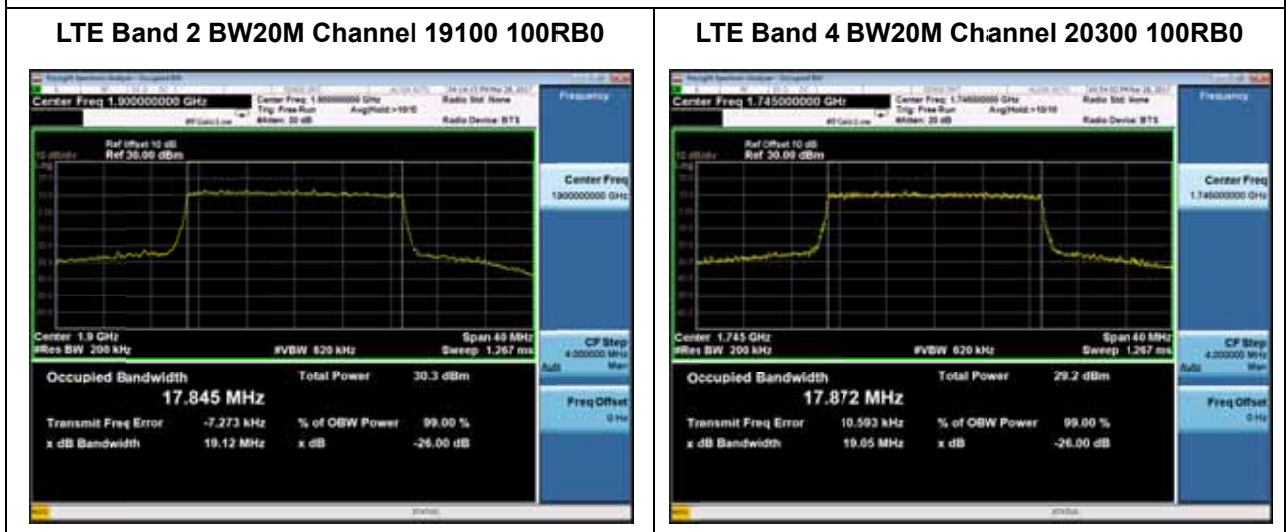

LTE Band 5 BW10M Channel 20600 50RB0



LTE Band 7 BW20M Channel 20850 100RB0



LTE Band 12 BW10M Channel 23130 50RB0



LTE Band 13 BW10M Channel 23230 50RB0



LTE Band 17 BW10M Channel 23790 50RB0

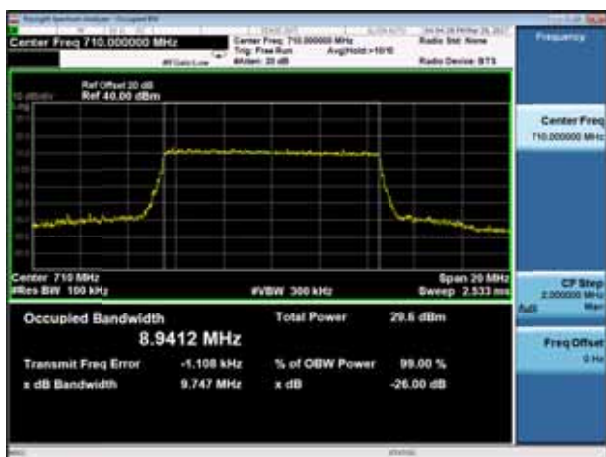

Product	Module	Test Site	AC-5
Test Item	Occupied Bandwidth	Date of Test	2017/03/29
Test Mode	Mode 1-7(16QAM)	Test engineer	Scott

Mode	Bandwidth (MHz)	Channel No.	Frequency (MHz)	99% Occupied Bandwidth (kHz)	-26dB Occupied Bandwidth (kHz)
LTE Band 2	20	18700	1860	17803	19030
		18900	1880	17836	18960
		19100	1900	17873	19070
	15	18675	1857.5	13342	14320
		18900	1880	13379	14380
		19125	1902.5	13393	14420
	10	18650	1855	8922.5	9554
		18900	1880	8921.3	9612
		19150	1905	8929.5	9631
	5	18625	1852.5	4468.9	4939
		18900	1880	4469	4870
		19175	1907.5	4475.7	4927
	3	18615	1851.5	2680.7	2945
		18900	1880	2682.3	2913
		19185	1908.5	2683.4	2899
	1.4	18607	1850.7	1077.7	1247
		18900	1880	1081.3	1275
		19193	1909.3	1077.8	1241
LTE Band 4	20	20050	1720	17863	19150
		20175	1732.5	17812	18940
		20300	1745	17809	18930
	15	20025	1717.5	13388	14450
		20175	1732.5	13357	14330
		20325	1747.5	13397	14310
	10	20000	1715	8954.5	9630
		20175	1732.5	8923	9654
		20350	1750	8936	9555
	5	19975	1712.5	4472.1	4944
		20175	1732.5	4452.4	4850
		20375	1752.5	4468.7	4896

	3	19965	1711.5	2678.4	2920	
		20175	1732.5	2677.5	2930	
		20385	1753.5	2683.2	2916	
	1.4	19957	1710.7	1078.1	1237	
		20175	1732.5	1078.1	1259	
		20393	1754.3	1080.1	1232	
LTE Band 5	10	20450	829	8925.3	9601	
		20525	836.5	8923.3	9520	
		20600	844	8941.1	9679	
	5	20425	826.5	4471.5	4934	
		20525	836.5	4467.1	4874	
		20625	846.5	4460.7	4912	
	3	20415	825.5	2681.7	2923	
		20525	836.5	2681.2	2936	
		20635	847.5	2681.1	2928	
	1.4	20407	824.7	1079.7	1245	
		20525	836.5	1081.4	1252	
		20643	848.3	1078.9	1236	
	LTE Band 7	20	20850	2510	17844	18980
			21100	2535	17813	18910
			21350	2560	17844	19110
15		20825	2507.5	13401	14290	
		21100	2535	13402	14430	
		21400	2562.5	13410	14360	
10		20800	2505	8925.5	9657	
		21100	2535	8935.3	9607	
		21400	2565	8920.9	9572	
5		20775	2502.5	4462.9	4924	
		21100	2535	4456.6	4912	
		21425	2567.5	4475	4887	
LTE Band 12		10	23060	704	8929.2	9599
			23095	707.5	8920.1	9580
			23130	711	8948.1	9567
	5	23035	701.5	4463.8	4867	
		23095	707.5	4457.7	4857	
		23155	713.5	4463.7	4912	
	3	23025	700.5	2679.6	2907	

	1.4	23095	707.5	2677.3	2880
		23165	714.5	2678.9	2899
		23017	699.7	1079.1	1240
		23095	707.5	1076.9	1212
		23173	715.3	1081.7	1246
LTE Band 13	10	23230	782	8891.8	9522
	5	23205	779.5	4458.2	4878
		23230	782	4459.8	4923
		23255	784.5	4454.9	4886
LTE Band 17	10	23780	709	8926.4	9613
		23790	710	8928.9	9695
		23800	711	8940.1	9630
	5	23755	706.5	4458.6	4852
		23790	710	4467.4	4886
		23825	713.5	4462.9	4900

Note1: The worst case as below:

LTE Band 2 BW20M Channel 19100 100RB0



LTE Band 4 BW20M Channel 20050 100RB0



LTE Band 5 BW10M Channel 20600 50RB0



LTE Band 7 BW20M Channel 20850 100RB0



LTE Band 12 BW10M Channel 23130 50RB0



LTE Band 13 BW10M Channel 23230 50RB0



LTE Band 17 BW10M Channel 23800 50RB0



6. Conducted Band Edge

6.1. Test Equipment

Conducted Band Edge / TR-8				
Instrument	Manufacturer	Type No.	Serial No	Cali. Due Date
PSA Series Spectrum Analyzer	Agilent	E4440A	MY49420184	2018.02.04
Radio Communication Tester	Anritsu	MT8820C	6201181503	2017.09.16
Dual Directional Coupler	Agilent	778D	20160	2018.02.04
10dB Coaxial Coupler	Agilent	87300C	MY44300299	2018.03.28
Temperature/Humidity Meter	Zhicheng	ZC1-2	AC6-TH	2018.01.05

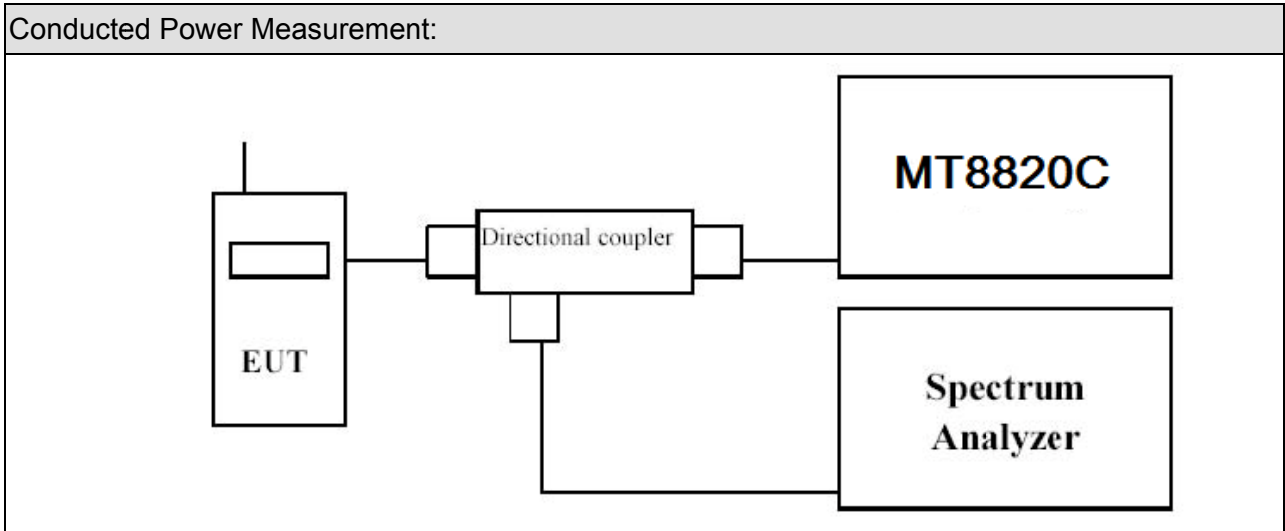

6.2. Test Procedure

Test Method for conducted test
<ol style="list-style-type: none"> 1. The EUT was connected to spectrum analyzer and System Simulator via power divider. 2. The RF output of EUT was connected to the spectrum analyzer by RF cable and attenuator. The path loss was compensated to the results for each measurement. 3. The conducted spurious emission for the whole frequency range was taken.

6.3. Test Result

Product	Module	Test Site	AC-5
Test Item	Conducted Band Edge	Date of Test	2017/03/29
Test Mode	Mode 1-7(QPSK)	Test engineer	Scott

Mode	Bandwidth (MHz)	Channel	Test Frequency (MHz)	RB	Measure Level (dBm)	Limit (dBm)	Result
LTE Band 2	20	18700	1860	1RB0	-31.778	<-13	Pass
				100RB0	-33.047	<-13	Pass
		19100	1900	1RB99	-30.237	<-13	Pass
				100RB0	-25.012	<-13	Pass
	15	18675	1857.5	1RB0	-24.700	<-13	Pass
				75RB0	-31.765	<-13	Pass
		19125	1902.5	1RB74	-23.942	<-13	Pass
				75RB0	-26.017	<-13	Pass
	10	18650	1855	1RB0	-16.019	<-13	Pass
				50RB0	-27.053	<-13	Pass
		19150	1905	1RB49	-15.078	<-13	Pass
				50RB0	-23.420	<-13	Pass
	5	18625	1852.5	1RB0	-18.536	<-13	Pass
				25RB0	-14.550	<-13	Pass
		19175	1907.5	1RB24	-16.279	<-13	Pass
				25RB0	-15.678	<-13	Pass
	3	18615	1851.5	1RB0	-18.311	<-13	Pass
				15RB0	-15.959	<-13	Pass
		19185	1908.5	1RB14	-15.818	<-13	Pass
				15RB0	-13.872	<-13	Pass
	1.4	18607	1850.7	1RB0	-13.729	<-13	Pass
				7RB0	-15.111	<-13	Pass
		19193	1909.3	1RB6	-17.004	<-13	Pass
				7RB0	-15.585	<-13	Pass
LTE Band 4	20	20050	1720	1RB0	-34.815	<-13	Pass
				100RB0	-29.560	<-13	Pass
		20300	1745	1RB99	-31.681	<-13	Pass
				100RB0	-23.383	<-13	Pass
	15	20025	1717.5	1RB0	-28.355	<-13	Pass

		20325	1747.5	75RB0	-29.529	<-13	Pass
				1RB74	-26.779	<-13	Pass
				75RB0	-22.377	<-13	Pass
	10	20000	1715	1RB0	-14.572	<-13	Pass
				50RB0	-28.044	<-13	Pass
		20350	1750	1RB49	-32.409	<-13	Pass
				50RB0	-25.555	<-13	Pass
	5	19975	1712.5	1RB0	-17.778	<-13	Pass
				25RB0	-17.142	<-13	Pass
		20375	1752.5	1RB24	-15.543	<-13	Pass
				25RB0	-15.113	<-13	Pass
	3	19965	1711.5	1RB0	-13.464	<-13	Pass
				15RB0	-14.070	<-13	Pass
		20385	1753.5	1RB14	-15.113	<-13	Pass
				15RB0	-14.497	<-13	Pass
	1.4	19957	1710.7	1RB0	-17.835	<-13	Pass
7RB0				-16.760	<-13	Pass	
20393		1754.3	1RB6	-17.954	<-13	Pass	
			7RB0	-16.619	<-13	Pass	
LTE Band 5	10	20450	829	1RB0	-33.984	<-13	Pass
				50RB0	-33.078	<-13	Pass
		20600	844	1RB49	-33.915	<-13	Pass
				50RB0	-35.026	<-13	Pass
	5	20425	826.5	1RB0	-24.181	<-13	Pass
				25RB0	-30.027	<-13	Pass
		20625	846.5	1RB24	-24.768	<-13	Pass
				25RB0	-31.706	<-13	Pass
	3	20415	825.5	1RB0	-24.417	<-13	Pass
				15RB0	-28.818	<-13	Pass
		20635	847.5	1RB14	-23.407	<-13	Pass
				15RB0	-30.334	<-13	Pass
	1.4	20407	824.7	1RB0	-28.532	<-13	Pass
				7RB0	-33.038	<-13	Pass
		20643	848.3	1RB6	-27.473	<-13	Pass
				7RB0	-32.284	<-13	Pass
LTE Band 7	20	20850	2510	1RB0	-34.233	<-10	Pass

		21350	2560	100RB0	-27.387	<-10	Pass
				1RB99	-32.934	<-10	Pass
				100RB0	-24.200	<-10	Pass
	15	20825	2507.5	1RB0	-28.150	<-10	Pass
				75RB0	-28.073	<-10	Pass
		21400	2562.5	1RB74	-27.945	<-10	Pass
				75RB0	-27.320	<-10	Pass
	10	20800	2505	1RB0	-14.580	<-10	Pass
				50RB0	-14.328	<-10	Pass
		21400	2565	1RB49	-14.885	<-10	Pass
				50RB0	-25.815	<-10	Pass
	5	20775	2502.5	1RB0	-23.456	<-10	Pass
25RB0				-15.249	<-10	Pass	
21425		2567.5	1RB24	-24.638	<-10	Pass	
			25RB0	-17.637	<-10	Pass	
LTE Band 12	10	23060	704	1RB0	-49.919	<-13	Pass
				50RB0	-41.642	<-13	Pass
		23130	711	1RB49	-32.596	<-13	Pass
				50RB0	-32.564	<-13	Pass
	5	23035	701.5	1RB0	-51.120	<-13	Pass
				25RB0	-39.388	<-13	Pass
		23155	713.5	1RB24	-23.802	<-13	Pass
				25RB0	-29.540	<-13	Pass
	3	23025	700.5	1RB0	-46.265	<-13	Pass
				15RB0	-38.143	<-13	Pass
		23165	714.5	1RB14	-21.398	<-13	Pass
				15RB0	-28.507	<-13	Pass
	1.4	23017	699.7	1RB0	-47.917	<-13	Pass
				7RB0	-41.208	<-13	Pass
		23173	715.3	1RB6	-25.870	<-13	Pass
				7RB0	-26.602	<-13	Pass
RLTE Band 13	5	23205	779.5	1RB0	-22.321	<-13	Pass
				25RB0	-28.198	<-13	Pass
		23255	784.5	1RB24	-22.750	<-13	Pass
				25RB0	-27.894	<-13	Pass
RLTE Band 17	10	23780	709	1RB0	-34.034	<-13	Pass
				50RB0	-31.292	<-13	Pass

5	23800	711	1RB49	-32.901	<-13	Pass
			50RB0	-32.745	<-13	Pass
	23755	706.5	1RB0	-22.976	<-13	Pass
			25RB0	-29.051	<-13	Pass
	23825	713.5	1RB24	-23.888	<-13	Pass
			25RB0	-24.556	<-13	Pass

Note: The worst case as below:

LTE Band 2 BW1.4M Channel 18607 1RB0



LTE Band 4 BW3M Channel 19965 1RB0

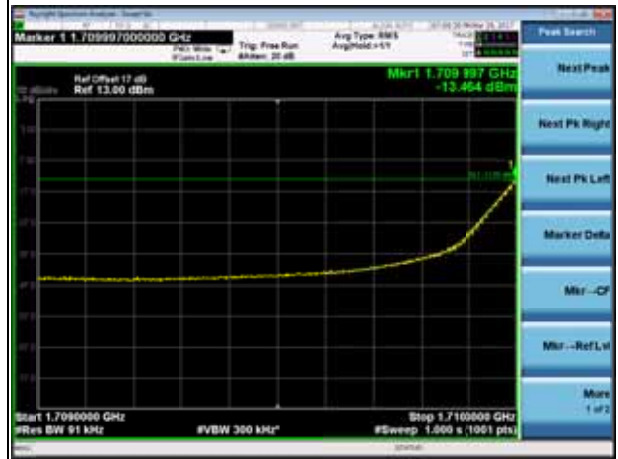

LTE Band 5 BW3M Channel 20635 1RB14

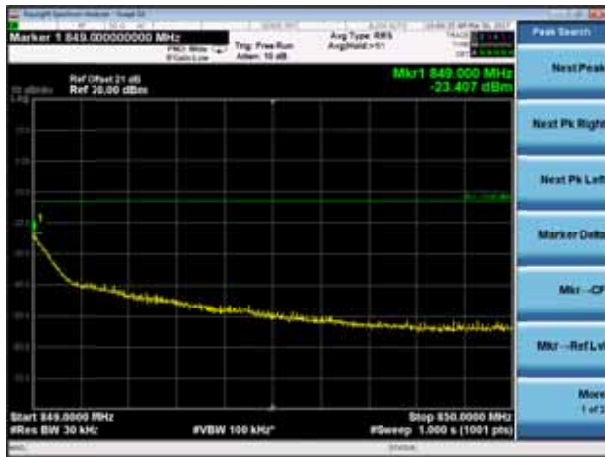

LTE Band 7 BW10M Channel 20800 50RB0

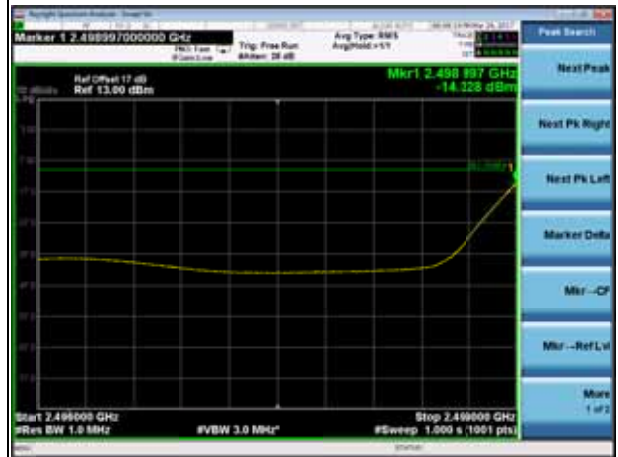

LTE Band 12 BW3M Channel 23165 1RB14

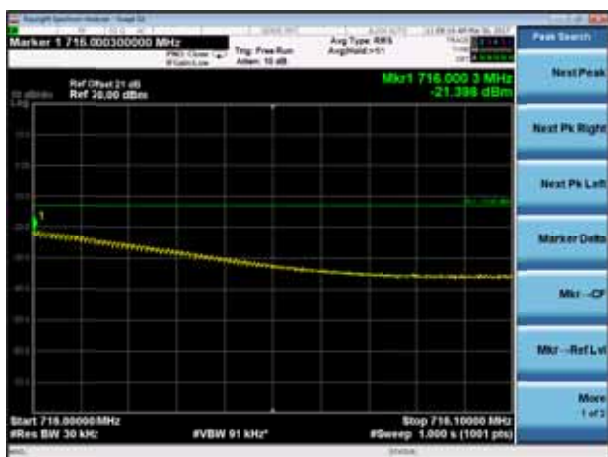

LTE Band 13 BW5M Channel 23205 1RB0

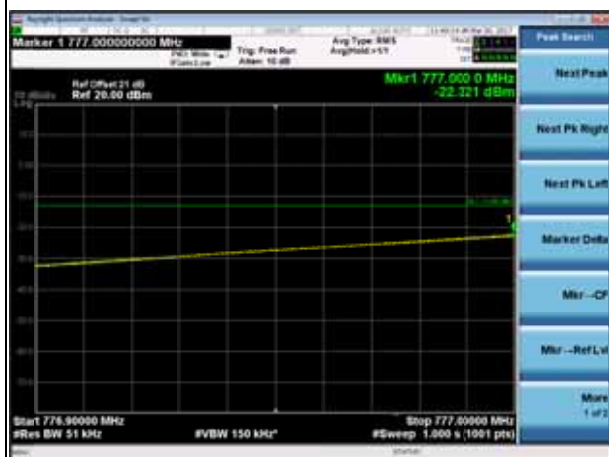

LTE Band 17 BW5M Channel 23755 1RB0

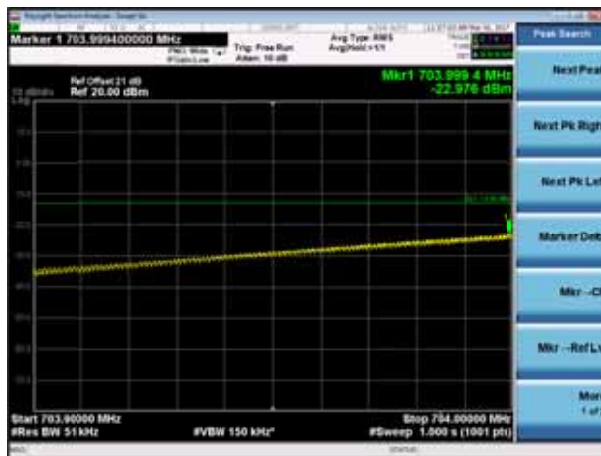

Product	Module	Test Site	AC-5
Test Item	Conducted Band Edge	Date of Test	2017/03/29
Test Mode	Mode 1-7(16QAM)	Test engineer	Scott

Mode	Bandwidth (MHz)	Channel	Test Frequency (MHz)	RB	Measure Level (dBm)	Limit (dBm)	Result
LTE Band 2	20	18700	1860	1RB0	-31.784	<-13	Pass
				100RB0	-33.418	<-13	Pass
		19100	1900	1RB99	-29.689	<-13	Pass
				100RB0	-24.716	<-13	Pass
	15	18675	1857.5	1RB0	-24.758	<-13	Pass
				75RB0	-31.837	<-13	Pass
		19125	1902.5	1RB74	-24.058	<-13	Pass
				75RB0	-25.648	<-13	Pass
	10	18650	1855	1RB0	-16.146	<-13	Pass
				50RB0	-26.924	<-13	Pass
		19150	1905	1RB49	-14.993	<-13	Pass
				50RB0	-23.392	<-13	Pass
	5	18625	1852.5	1RB0	-18.706	<-13	Pass
				25RB0	-14.479	<-13	Pass
		19175	1907.5	1RB24	-16.258	<-13	Pass
				25RB0	-15.803	<-13	Pass
	3	18615	1851.5	1RB0	-18.501	<-13	Pass
				15RB0	-15.632	<-13	Pass
		19185	1908.5	1RB14	-15.687	<-13	Pass
				15RB0	-13.739	<-13	Pass
	1.4	18607	1850.7	1RB0	-13.776	<-13	Pass
				7RB0	-16.863	<-13	Pass
		19193	1909.3	1RB6	-15.907	<-13	Pass
				7RB0	-14.807	<-13	Pass
LTE Band 4	20	20050	1720	1RB0	-35.017	<-13	Pass
				100RB0	-29.608	<-13	Pass
		20300	1745	1RB99	-31.986	<-13	Pass
				100RB0	-23.653	<-13	Pass
	15	20025	1717.5	1RB0	-27.630	<-13	Pass
				75RB0	-29.513	<-13	Pass

		20325	1747.5	1RB74	-27.149	<-13	Pass
				75RB0	-22.524	<-13	Pass
	10	20000	1715	1RB0	-14.675	<-13	Pass
				50RB0	-27.980	<-13	Pass
		20350	1750	1RB49	-32.409	<-13	Pass
				50RB0	-25.475	<-13	Pass
	5	19975	1712.5	1RB0	-14.108	<-13	Pass
				25RB0	-17.234	<-13	Pass
		20375	1752.5	1RB24	-15.206	<-13	Pass
				25RB0	-14.845	<-13	Pass
	3	19965	1711.5	1RB0	-13.290	<-13	Pass
				15RB0	-14.352	<-13	Pass
		20385	1753.5	1RB14	-14.328	<-13	Pass
				15RB0	-14.626	<-13	Pass
	1.4	19957	1710.7	1RB0	-14.873	<-13	Pass
				7RB0	-16.838	<-13	Pass
20393		1754.3	1RB6	-18.006	<-13	Pass	
			7RB0	-16.355	<-13	Pass	
LTE Band 5	10	20450	829	1RB0	-34.346	<-13	Pass
				50RB0	-32.862	<-13	Pass
		20600	844	1RB49	-34.142	<-13	Pass
				50RB0	-34.897	<-13	Pass
	5	20425	826.5	1RB0	-24.929	<-13	Pass
				25RB0	-29.949	<-13	Pass
		20625	846.5	1RB24	-24.867	<-13	Pass
				25RB0	-31.302	<-13	Pass
	3	20415	825.5	1RB0	-24.561	<-13	Pass
				15RB0	-29.503	<-13	Pass
		20635	847.5	1RB14	-23.628	<-13	Pass
				15RB0	-31.448	<-13	Pass
	1.4	20407	824.7	1RB0	-29.623	<-13	Pass
				7RB0	-32.956	<-13	Pass
		20643	848.3	1RB6	-28.588	<-13	Pass
				7RB0	-32.838	<-13	Pass
LTE Band 7	20	20850	2510	1RB0	-33.352	<-10	Pass
				100RB0	-27.275	<-10	Pass

		21350	2560	1RB99	-33.006	<-10	Pass
				100RB0	-23.963	<-10	Pass
	15	20825	2507.5	1RB0	-27.973	<-10	Pass
				75RB0	-28.053	<-10	Pass
		21400	2562.5	1RB74	-28.467	<-10	Pass
				75RB0	-26.711	<-10	Pass
	10	20800	2505	1RB0	-14.421	<-10	Pass
				50RB0	-14.454	<-10	Pass
		21400	2565	1RB49	-14.574	<-10	Pass
				50RB0	-26.469	<-10	Pass
	5	20775	2502.5	1RB0	-23.407	<-10	Pass
				25RB0	-15.388	<-10	Pass
21425		2567.5	1RB24	-24.104	<-10	Pass	
			25RB0	-17.772	<-10	Pass	
LTE Band 12	10	23060	704	1RB0	-50.072	<-13	Pass
				50RB0	-41.469	<-13	Pass
		23130	711	1RB49	-32.804	<-13	Pass
				50RB0	-32.509	<-13	Pass
	5	23035	701.5	1RB0	-51.131	<-13	Pass
				25RB0	-39.711	<-13	Pass
		23155	713.5	1RB24	-24.127	<-13	Pass
				25RB0	-29.847	<-13	Pass
	3	23025	700.5	1RB0	-46.275	<-13	Pass
				15RB0	-37.727	<-13	Pass
		23165	714.5	1RB14	-21.442	<-13	Pass
				15RB0	-28.682	<-13	Pass
	1.4	23017	699.7	1RB0	-48.441	<-13	Pass
				7RB0	-41.218	<-13	Pass
		23173	715.3	1RB6	-26.031	<-13	Pass
				7RB0	-26.644	<-13	Pass
RLTE Band 13	5	23205	779.5	1RB0	-22.585	<-13	Pass
				25RB0	-28.434	<-13	Pass
		23255	784.5	1RB24	-22.362	<-13	Pass
				25RB0	-27.729	<-13	Pass
RLTE Band 17	10	23780	709	1RB0	-33.490	<-13	Pass
				50RB0	-31.347	<-13	Pass
		23800	711	1RB49	-33.101	<-13	Pass

				50RB0	-32.766	<-13	Pass
	5	23755	706.5	1RB0	-22.918	<-13	Pass
				25RB0	-29.211	<-13	Pass
	5	23825	713.5	1RB24	-24.411	<-13	Pass
				25RB0	-28.645	<-13	Pass

Note: The worst case as below:

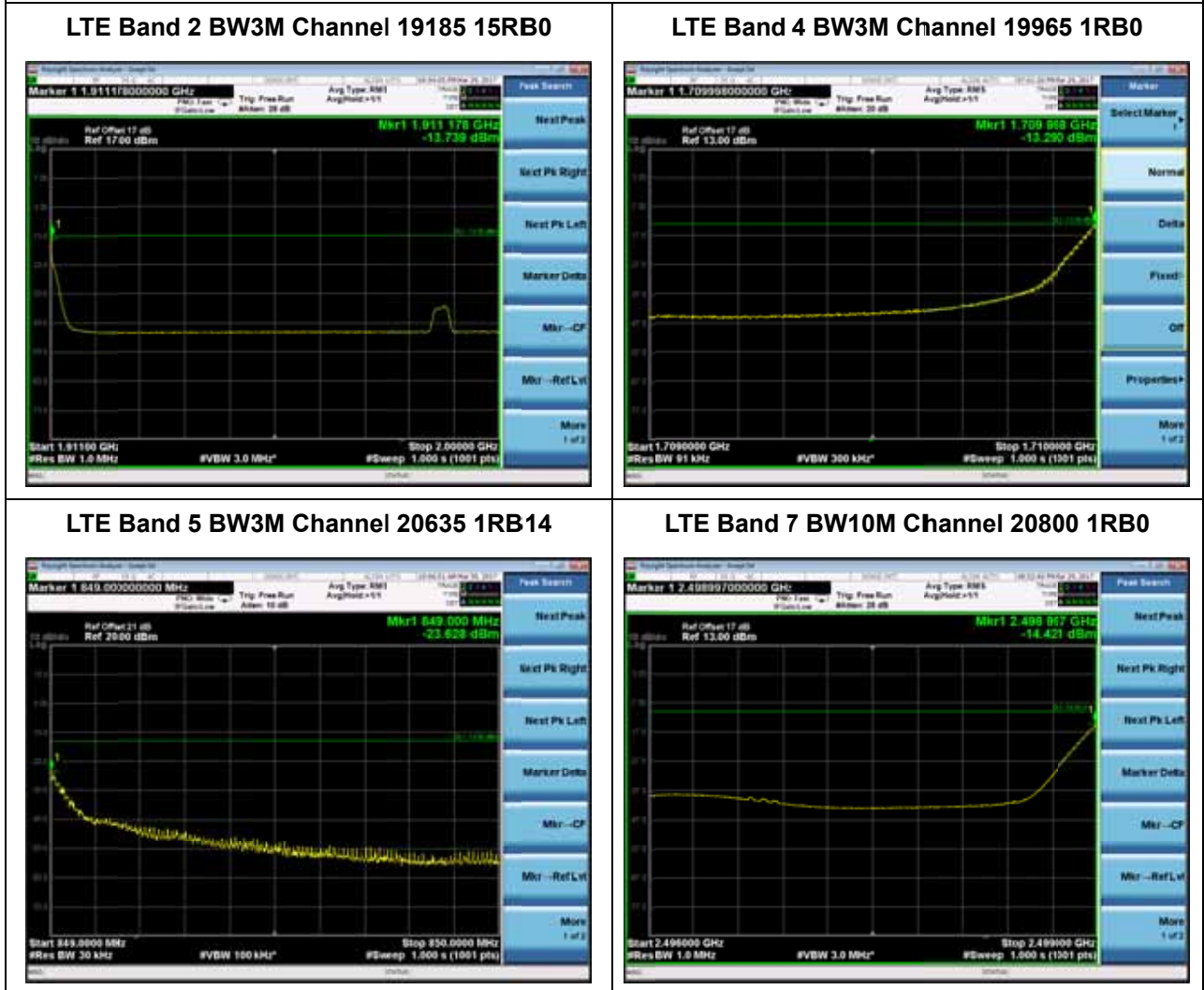

LTE Band 12 BW3M Channel 23165 1RB14

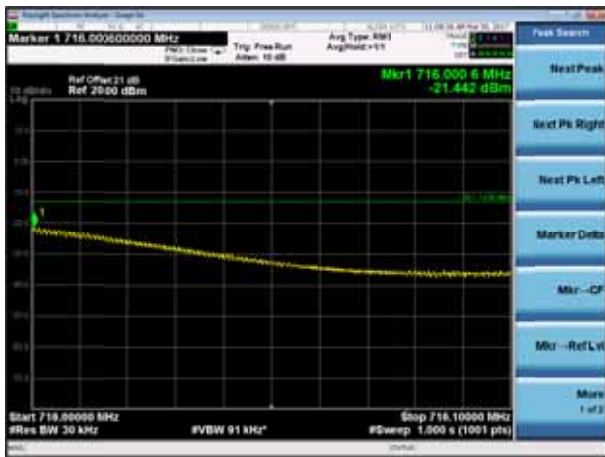

LTE Band 13 BW5M Channel 23255 1RB24



LTE Band 17 BW5M Channel 23755 1RB0

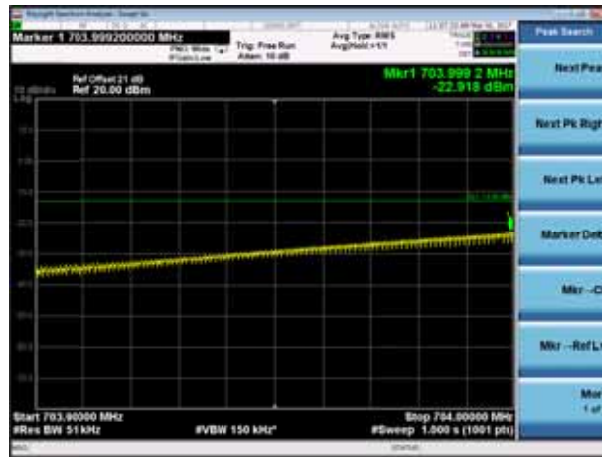

7. Spurious Emission

7.1. Test Equipment

Spurious Emission / AC-5				
Instrument	Manufacturer	Type No.	Serial No	Cali. Due Date
PSA Series Spectrum Analyzer	Agilent	E4440A	MY49420184	2018.02.04
Radio Communication Tester	Anritsu	MT8820C	6201181503	2017.09.16
Dual Directional Coupler	Agilent	778D	20160	2018.02.04
10dB Coaxial Coupler	Agilent	87300C	MY44300299	2018.03.28
PSG Analog Signal Generator	Agilent	E8257D	MY44321116	2018.02.04
Preamplifier	QuieTek	AP-025C	CHM-0503006	2017.04.11
Preamplifier	Miteq	NSP1800-25	1364185	2017.05.03
Bilog Antenna	Teseq GmbH	CBL6112D	27612	2018.01.23
Half Wave Tuned Dipole Antenna	COM-POWER	AD-100	40137	2018.02.26
Broad-Band Horn Antenna	Schwarzbeck	BBHA9120D	737	2018.03.06
DRG Horn	ETS-Lindgren	3117	00167055	2017.07.23
Temperature/Humidity Meter	Zhicheng	ZC1-2	AC5-TH	2018.01.05

7.2. Test Setup

Conducted Power Measurement:

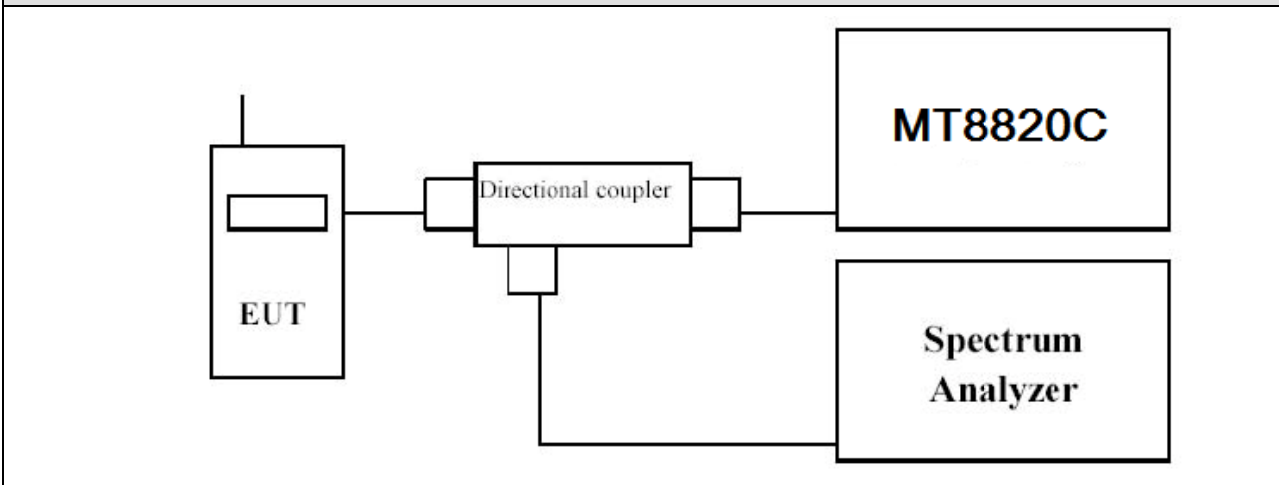

Radiated Power Measurement (Below 1G):

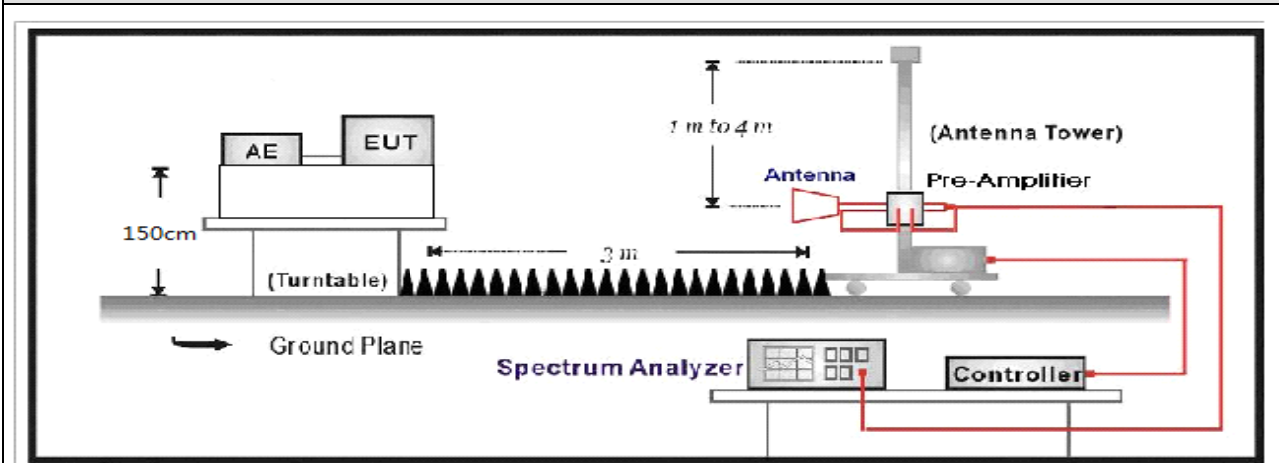

Radiated Power Measurement (Above 1G):

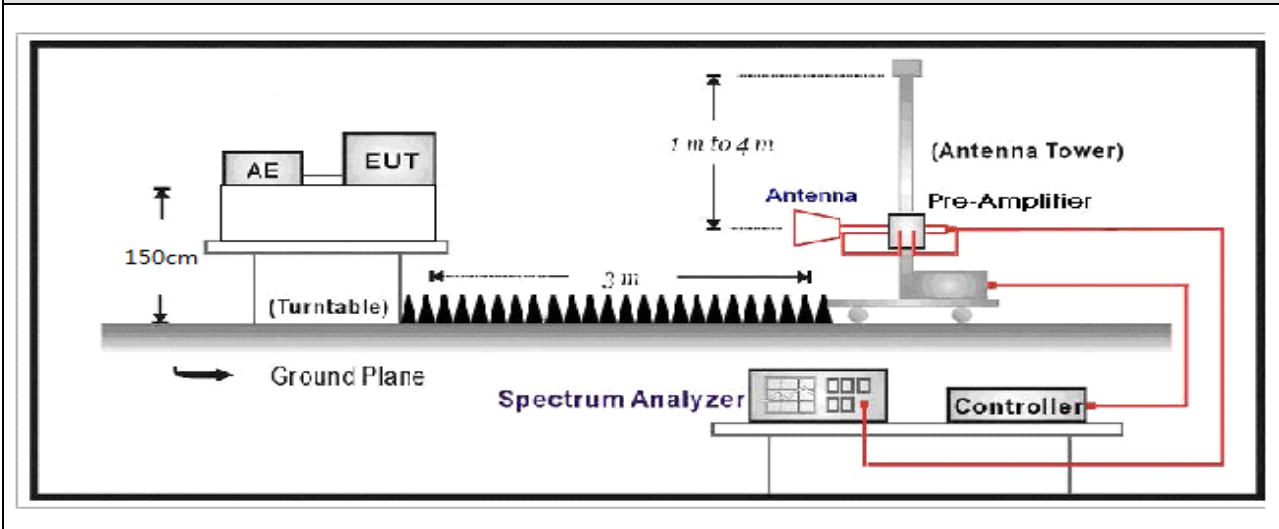

7.3. Test Procedure

Test Method for conducted power

- a) The RF output of the transmitter was connected to base station simulator.
- b) The RF output of EUT was connected to the spectrum analyzer by RF cable and attenuator.
The path loss was compensated to the results for each measurement.
- c) Set EUT at maximum average power by base station simulator.
- d) Measure lowest, middle, and highest channels for each bandwidth and different modulation.

Test For Effective Isotropic Radiated Power Measurement:

- a) The EUT was placed on a turntable with 1.5 meter height in a fully anechoic chamber.
- b) The EUT was set at 3 meters from the receiving antenna, which was mounted on the antenna tower
- c) LTE operating modes: use channel power function to test
- d) The table was rotated 360 degrees to determine the position of the highest radiated power.
- e) The height of the receiving antenna is adjusted to look for the maximum EIRP.
- f) The maximum EIRP shall be record.
- g) A dipole antenna was substituted in place of the EUT and was driven by a signal generator.
- h) The conducted power at the terminal of the dipole antenna is measured.
- i) Repeat step c) to step h) to get the maximum EIRP of the substitution antenna.
- j) $EIRP = P_s + E_t - E_s + G_s = P_s + R_t - R_s + G_s$.
- k) P_s (dBm): Input power to substitution antenna
- l) G_s (dBi or dBd): Substitution antenna Gain.
- m) $E_t = R_t + AF$
- n) $E_s = R_s + AF$
- o) AF (dB/m): Receive antenna factor
- p) R_t : The highest received signal in spectrum analyzer for EUT.
- q) R_s : The highest received signal in spectrum analyzer for substitution antenna.

7.4. Test Result

Product	Module	Test Site	AC-5
Test Item	Conducted Spurious Emission	Date of Test	2017/03/29
Test Mode	Mode 1-7(QPSK)	Test engineer	Scott

Mode	Bandwidth (MHz)	Channel	Test Frequency (MHz)	RB	Measure Level (dBm)	Limit (dBm)	Result	
LTE Band 2	20	18700	1860	1RB0	-59.054	<-13	Pass	
		18900	1880	1RB0	-58.623	<-13	Pass	
		19100	1900	1RB0	-59.645	<-13	Pass	
	15	18675	1857.5	1RB0	-58.067	<-13	Pass	
		18900	1880	1RB0	-58.859	<-13	Pass	
		19125	1902.5	1RB0	-58.062	<-13	Pass	
	10	18650	1855	1RB0	-58.335	<-13	Pass	
		18900	1880	1RB0	-58.295	<-13	Pass	
		19150	1905	1RB0	-59.528	<-13	Pass	
	5	18625	1852.5	1RB0	-58.509	<-13	Pass	
		18900	1880	1RB0	-58.872	<-13	Pass	
		19175	1907.5	1RB0	-58.554	<-13	Pass	
	3	18615	1851.5	1RB0	-58.350	<-13	Pass	
		18900	1880	1RB0	-58.015	<-13	Pass	
		19185	1908.5	1RB0	-59.354	<-13	Pass	
	1.4	18607	1850.7	1RB0	-58.245	<-13	Pass	
		18900	1880	1RB0	-58.696	<-13	Pass	
		19193	1909.3	1RB0	-58.387	<-13	Pass	
	LTE Band 4	20	20050	1720	1RB0	-59.452	<-13	Pass
			20175	1732.5	1RB0	-58.071	<-13	Pass
			20030	1745	1RB0	-58.834	<-13	Pass
15		20025	1717.5	1RB0	-58.219	<-13	Pass	
		20175	1732.5	1RB0	-58.768	<-13	Pass	
		20325	1747.5	1RB0	-58.172	<-13	Pass	
10		20000	1715	1RB0	-57.547	<-13	Pass	
		20175	1732.5	1RB0	-58.905	<-13	Pass	
		20350	1750	1RB0	-58.546	<-13	Pass	
5		19975	1712.5	1RB0	-58.134	<-13	Pass	

		20175	1732.5	1RB0	-59.119	<-13	Pass
		20375	1752.5	1RB0	-58.984	<-13	Pass
	3	19965	1711.5	1RB0	-58.093	<-13	Pass
		20175	1732.5	1RB0	-58.046	<-13	Pass
		20385	1753.5	1RB0	-59.429	<-13	Pass
	1.4	19957	1710.7	1RB0	-59.658	<-13	Pass
		20175	1732.5	1RB0	-57.436	<-13	Pass
		20393	1754.3	1RB0	-59.527	<-13	Pass
	LTE Band 5	10	20450	829	1RB0	-48.978	<-13
20525			836.5	1RB0	-49.237	<-13	Pass
20600			844	1RB0	-50.057	<-13	Pass
5		20425	826.5	1RB0	-50.198	<-13	Pass
		20525	836.5	1RB0	-48.739	<-13	Pass
		20625	846.5	1RB0	-50.526	<-13	Pass
3		20415	825.5	1RB0	-50.471	<-13	Pass
		20525	836.5	1RB0	-48.582	<-13	Pass
		20635	847.5	1RB0	-49.997	<-13	Pass
1.4		20407	824.7	1RB0	-50.092	<-13	Pass
		20525	836.5	1RB0	-49.675	<-13	Pass
		20643	848.3	1RB0	-49.879	<-13	Pass
LTE Band 7	20	20850	2510	1RB99	-53.397	<-13	Pass
		21100	2535	1RB99	-52.781	<-13	Pass
		21350	2560	1RB0	-52.255	<-13	Pass
	15	20825	2507.5	1RB0	-53.172	<-13	Pass
		21100	2535	1RB74	-52.956	<-13	Pass
		21375	2562.5	1RB0	-53.499	<-13	Pass
	10	20800	2505	1RB48	-52.697	<-13	Pass
		21100	2535	1RB0	-53.474	<-13	Pass
		21400	2565	1RB0	-52.659	<-13	Pass
	5	20775	2502.5	1RB0	-51.709	<-13	Pass
		21100	2535	1RB0	-52.620	<-13	Pass
		21425	2567.5	1RB0	-53.814	<-13	Pass
LTE Band 12	10	23060	704	1RB49	-49.700	<-13	Pass
		23095	707.5	1RB49	-49.553	<-13	Pass
		23130	711	1RB49	-49.313	<-13	Pass
	5	23035	701.5	1RB0	-50.384	<-13	Pass
		23095	707.5	1RB12	-50.322	<-13	Pass

	3	23155	713.5	1RB12	-50.268	<-13	Pass
		23025	700.5	1RB7	-49.454	<-13	Pass
		23095	707.5	1RB7	-50.345	<-13	Pass
		23165	714.5	1RB14	-49.717	<-13	Pass
	1.4	23017	699.7	1RB2	-50.396	<-13	Pass
		23095	707.5	1RB5	-50.887	<-13	Pass
		23173	715.3	1RB5	-50.391	<-13	Pass
LTE Band 13	10	20525	836.5	1RB0	-50.657	<-13	Pass
		23205	779.5	1RB0	-50.110	<-13	Pass
	5	23230	782	1RB0	-49.368	<-13	Pass
		23255	784.5	1RB0	-50.213	<-13	Pass
LTE Band 17	10	23780	709	1RB0	-49.777	<-13	Pass
		23790	710	1RB0	-49.153	<-13	Pass
		23800	711	1RB0	-49.560	<-13	Pass
	5	23755	706.5	1RB0	-49.870	<-13	Pass
		23790	710	1RB0	-49.814	<-13	Pass
		23825	713.5	1RB0	-50.403	<-13	Pass

Note: The worst case as below:

LTE Band 2 BW3M Channel 18900 1RB0

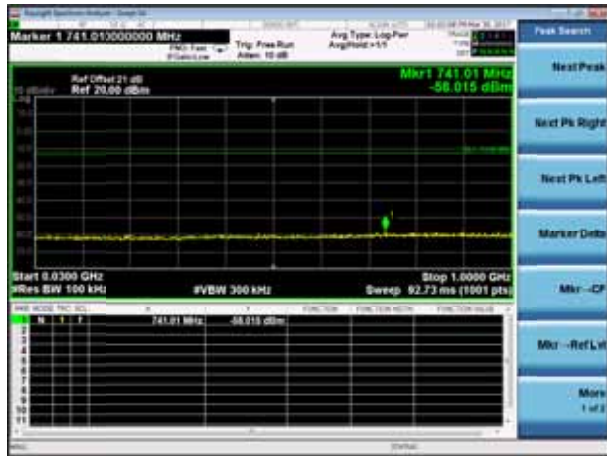

LTE Band 4 BW1.4M Channel 20175 1RB0

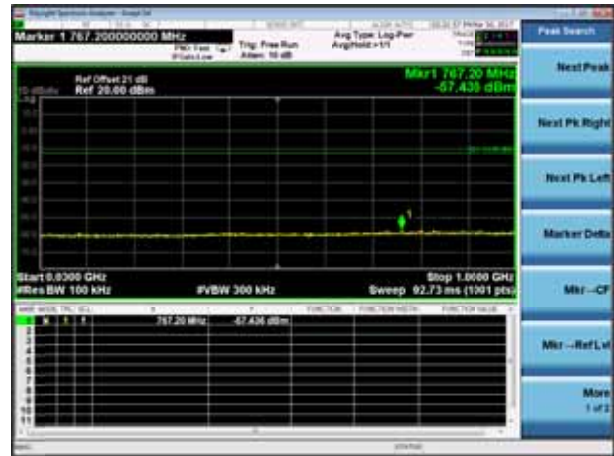

LTE Band 5 BW3M Channel 20525 1RB0

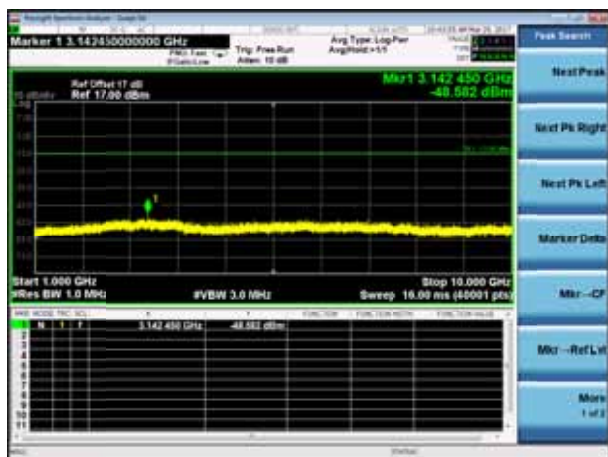

LTE Band 7 BW5M Channel 20775 1RB0

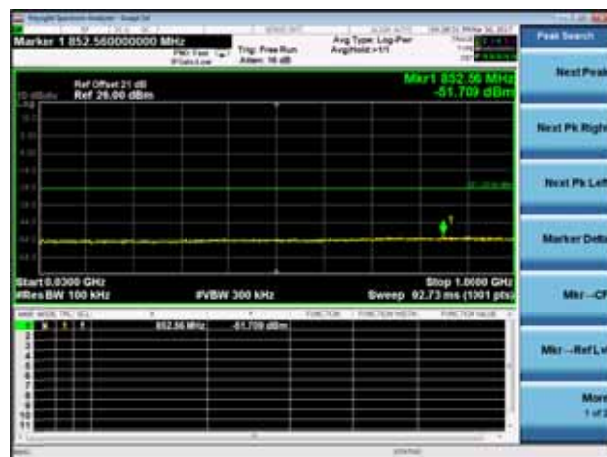

LTE Band 12 BW10M Channel 23130 1RB49

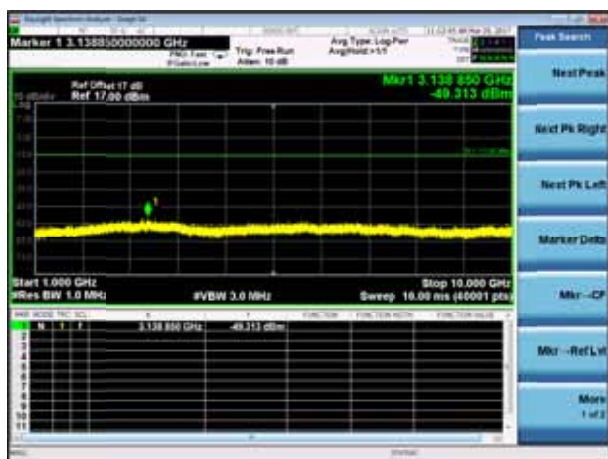

LTE Band 13 BW5M Channel 23230 1RB0

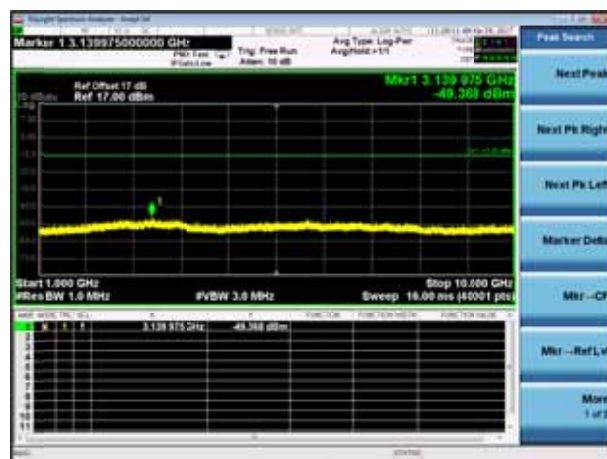

LTE Band 17 BW10M Channel 23790 1RB0

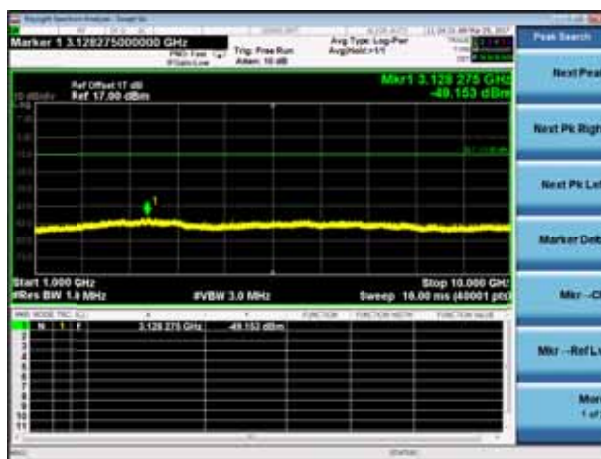

Product	Module	Test Site	AC-5
Test Item	Conducted Spurious Emission	Date of Test	2017/03/29
Test Mode	Mode 1-7(16QAM)	Test engineer	Scott

Mode	Bandwidth (MHz)	Channel	Test Frequency (MHz)	RB	Measure Level (dBm)	Limit (dBm)	Result
LTE Band 2	20	18700	1860	1RB0	-59.630	<-13	Pass
		18900	1880	1RB0	-57.815	<-13	Pass
		19100	1900	1RB0	-57.114	<-13	Pass
	15	18675	1857.5	1RB0	-58.386	<-13	Pass
		18900	1880	1RB0	-59.027	<-13	Pass
		19125	1902.5	1RB0	-58.985	<-13	Pass
	10	18650	1855	1RB0	-58.685	<-13	Pass
		18900	1880	1RB0	-58.104	<-13	Pass
		19150	1905	1RB0	-59.278	<-13	Pass
	5	18625	1852.5	1RB0	-58.969	<-13	Pass
		18900	1880	1RB0	-58.634	<-13	Pass
		19175	1907.5	1RB0	-59.431	<-13	Pass
	3	18615	1851.5	1RB0	-57.731	<-13	Pass
		18900	1880	1RB0	-59.035	<-13	Pass
		19185	1908.5	1RB0	-58.836	<-13	Pass
	1.4	18607	1850.7	1RB0	-59.645	<-13	Pass
		18900	1880	1RB0	-57.859	<-13	Pass
		19193	1909.3	1RB0	-58.625	<-13	Pass
LTE Band 4	20	20050	1720	1RB0	-57.945	<-13	Pass
		20175	1732.5	1RB0	-58.123	<-13	Pass
		20030	1745	1RB0	-59.419	<-13	Pass
	15	20025	1717.5	1RB0	-58.611	<-13	Pass
		20175	1732.5	1RB0	-58.446	<-13	Pass
		20325	1747.5	1RB0	-59.684	<-13	Pass
	10	20000	1715	1RB0	-59.381	<-13	Pass
		20175	1732.5	1RB0	-58.320	<-13	Pass
		20350	1750	1RB0	-59.195	<-13	Pass
	5	19975	1712.5	1RB0	-57.825	<-13	Pass
		20175	1732.5	1RB0	-58.451	<-13	Pass
		20375	1752.5	1RB0	-59.121	<-13	Pass

	3	19965	1711.5	1RB0	-58.818	<-13	Pass
		20175	1732.5	1RB0	-57.806	<-13	Pass
		20385	1753.5	1RB0	-59.813	<-13	Pass
	1.4	19957	1710.7	1RB0	-58.335	<-13	Pass
		20175	1732.5	1RB0	-57.790	<-13	Pass
		20393	1754.3	1RB0	-59.246	<-13	Pass
LTE Band 5	10	20450	829	1RB0	-49.996	<-13	Pass
		20525	836.5	1RB0	-50.350	<-13	Pass
		20600	844	1RB0	-49.606	<-13	Pass
	5	20425	826.5	1RB0	-50.057	<-13	Pass
		20525	836.5	1RB0	-49.451	<-13	Pass
		20625	846.5	1RB0	-50.833	<-13	Pass
	3	20415	825.5	1RB0	-50.547	<-13	Pass
		20525	836.5	1RB0	-50.666	<-13	Pass
		20635	847.5	1RB0	-49.893	<-13	Pass
	1.4	20407	824.7	1RB0	-48.932	<-13	Pass
		20525	836.5	1RB0	-50.524	<-13	Pass
		20643	848.3	1RB0	-50.146	<-13	Pass
LTE Band 7	20	20850	2510	1RB99	-53.551	<-13	Pass
		21100	2535	1RB99	-52.776	<-13	Pass
		21350	2560	1RB0	-53.650	<-13	Pass
	15	20825	2507.5	1RB0	-52.183	<-13	Pass
		21100	2535	1RB74	-53.210	<-13	Pass
		21375	2562.5	1RB0	-52.754	<-13	Pass
	10	20800	2505	1RB48	-52.940	<-13	Pass
		21100	2535	1RB0	-52.304	<-13	Pass
		21400	2565	1RB0	-53.200	<-13	Pass
	5	20775	2502.5	1RB0	-52.255	<-13	Pass
		21100	2535	1RB0	-51.400	<-13	Pass
		21425	2567.5	1RB0	-51.973	<-13	Pass
LTE Band 12	10	23060	704	1RB49	-50.136	<-13	Pass
		23095	707.5	1RB49	-50.351	<-13	Pass
		23130	711	1RB49	-49.170	<-13	Pass
	5	23035	701.5	1RB0	-49.864	<-13	Pass
		23095	707.5	1RB12	-49.604	<-13	Pass
		23155	713.5	1RB12	-49.852	<-13	Pass
3	23025	700.5	1RB7	-49.484	<-13	Pass	

	1.4	23095	707.5	1RB7	-50.554	<-13	Pass
		23165	714.5	1RB14	-50.735	<-13	Pass
		23017	699.7	1RB2	-49.468	<-13	Pass
		23095	707.5	1RB5	-50.457	<-13	Pass
		23173	715.3	1RB5	-49.886	<-13	Pass
LTE Band 13	10	20525	836.5	1RB0	-49.178	<-13	Pass
		23205	779.5	1RB0	-49.416	<-13	Pass
	5	23230	782	1RB0	-49.698	<-13	Pass
		23255	784.5	1RB0	-49.272	<-13	Pass
LTE Band 17	10	23780	709	1RB0	-50.202	<-13	Pass
		23790	710	1RB0	-50.598	<-13	Pass
		23800	711	1RB0	-49.433	<-13	Pass
	5	23755	706.5	1RB0	-49.760	<-13	Pass
		23790	710	1RB0	-50.541	<-13	Pass
		23825	713.5	1RB0	-49.729	<-13	Pass

Note: The worst case as below:

LTE Band 2 BW20M Channel 19100 1RB0

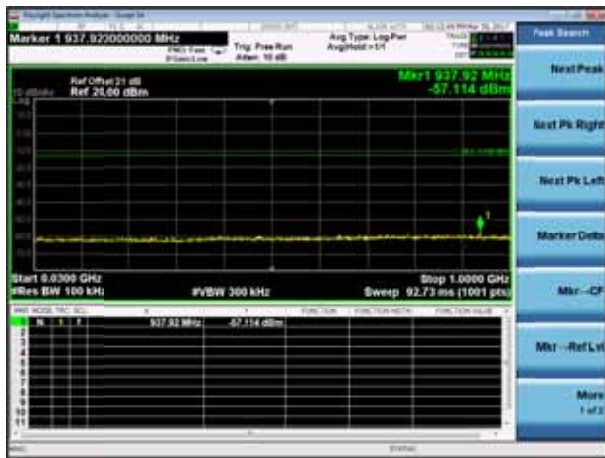

LTE Band 4 BW3M Channel 20175 1RB0

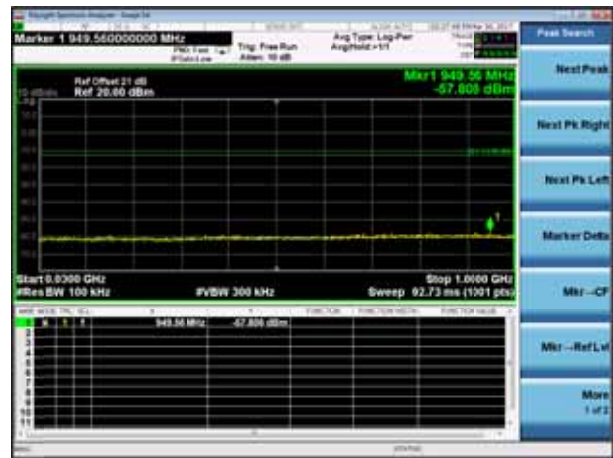

LTE Band 5 BW1.4M Channel 20407 1RB0

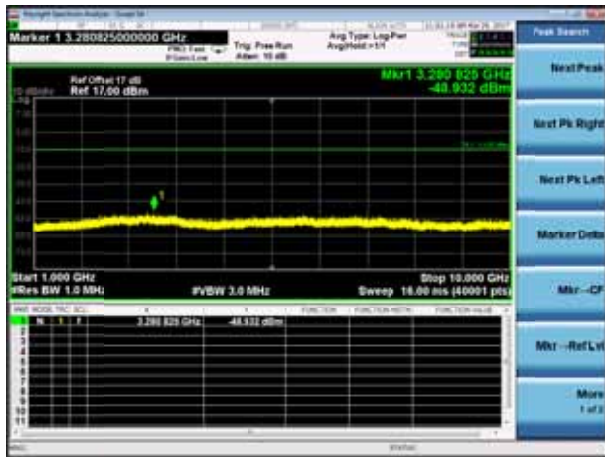

LTE Band 7 BW5M Channel 21100 1RB0



LTE Band 12 BW3M Channel 23025 1RB7

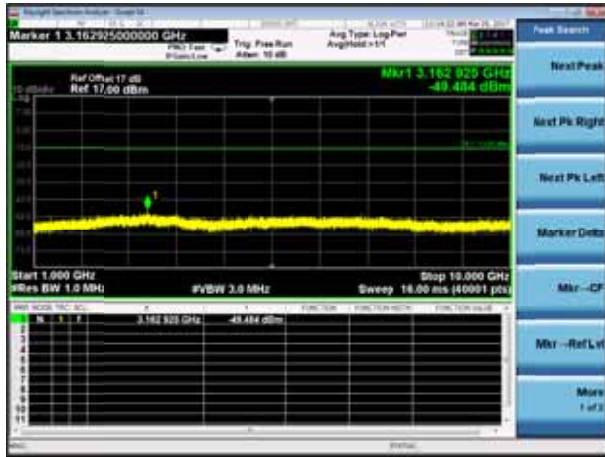

LTE Band 13 BW5M Channel 23255 1RB0

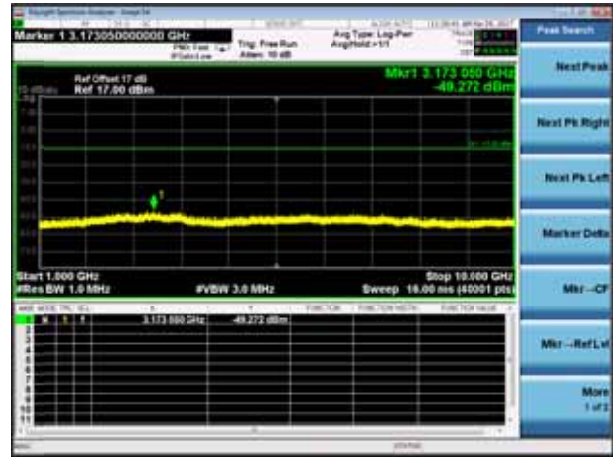

LTE Band 17 BW10M Channel 23800 1RB0

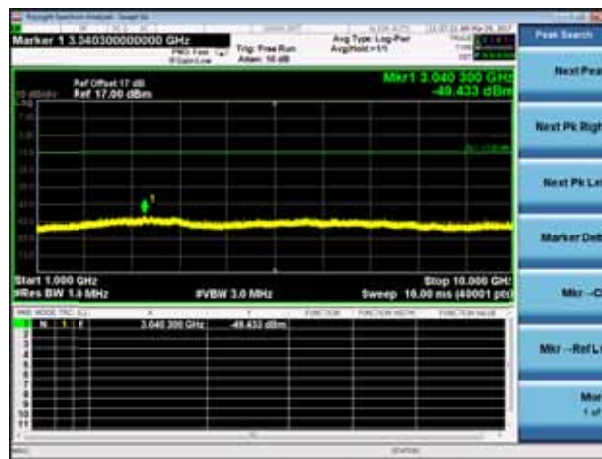

Product	Module	Test Site	AC-5
Test Item	Radiated Spurious Emission	Date of Test	2017/03/29
Test Mode	Mode1: LTE Band 2 Link QPSK/16QAM 20MHz	Test engineer	Scott

Frequency (MHz)	SA Reading (dBm)	Ant.Pol. (H/V)	SG Reading (dBm)	Cable Loss (dB)	Gain (dBi)	EIRP (dBm)	Limit (dBm)	Over Limit (dB)
Low Channel 18700 (1860MHz) BW20MHz 1RB0								
3720.00	-56.02	V	-64.79	4.79	12.71	-56.87	-13.00	-43.87
5580.00	-56.06	V	-58.03	4.83	13.16	-49.70	-13.00	-36.70
3720.00	-52.89	H	-64.09	4.79	12.71	-56.17	-13.00	-43.17
5580.00	-50.34	H	-61.44	4.83	13.16	-53.11	-13.00	-40.11
Middle Channel 18900 (1880.00MHz) BW20MHz 1RB0								
3760.00	-56.19	V	-64.16	5.03	12.72	-56.47	-13.00	-43.47
5640.00	-55.97	V	-61.00	5.93	13.14	-53.79	-13.00	-40.79
3760.00	-51.65	H	-65.88	5.03	12.72	-58.19	-13.00	-45.19
5640.00	-50.95	H	-61.09	5.93	13.14	-53.88	-13.00	-40.88
High Channel 19100 (1900.00MHz) BW20MHz 1RB0								
3800.00	-53.84	V	-64.35	5.05	12.74	-56.66	-13.00	-43.66
5700.00	-53.34	V	-61.95	4.85	13.26	-53.54	-13.00	-40.54
3800.00	-52.54	H	-65.56	5.03	12.76	-57.83	-13.00	-44.83
5700.00	-52.33	H	-62.22	4.87	13.12	-53.97	-13.00	-40.97
Note: We have evaluated all bandwidth and channels by modulation of QPSK and 16QAM, shown in the report are worst case.								

Product	Module	Test Site	AC-5
Test Item	Radiated Spurious Emission	Date of Test	2017/03/29
Test Mode	Mode1: LTE Band 2 Link QPSK/16QAM 15MHz	Test engineer	Scott

Frequency (MHz)	SA Reading (dBm)	Ant.Pol. (H/V)	SG Reading (dBm)	Cable Loss (dB)	Gain (dBi)	EIRP (dBm)	Limit (dBm)	Over Limit (dB)
Low Channel 18675 (1857.5MHz) BW15MHz 1RB0								
3715.00	-52.09	V	-64.79	4.79	12.71	-56.87	-13.00	-43.87
5572.50	-55.14	V	-62.34	4.83	13.16	-54.01	-13.00	-41.01
3715.00	-51.60	H	-64.47	4.79	12.71	-56.55	-13.00	-43.55
5572.50	-53.78	H	-62.78	4.83	13.16	-54.45	-13.00	-41.45
Middle Channel 18900 (1880.00MHz) BW15MHz 1RB0								
3760.00	-56.99	V	-65.69	5.03	12.72	-58.00	-13.00	-45.00
5640.00	-55.95	V	-61.79	5.93	13.14	-54.58	-13.00	-41.58
3760.00	-50.95	H	-65.38	5.03	12.72	-57.69	-13.00	-44.69
5640.00	-52.76	H	-61.58	5.93	13.14	-54.37	-13.00	-41.37
High Channel 19125 (1902.50MHz) BW15MHz 1RB0								
3805.00	-49.74	V	-65.63	5.02	12.72	-57.93	-13.00	-44.93
5707.50	-55.54	V	-62.30	4.86	13.10	-54.06	-13.00	-41.06
3805.00	-51.69	H	-65.75	5.02	12.72	-58.05	-13.00	-45.05
5707.50	-55.06	H	-60.42	4.86	13.10	-52.18	-13.00	-39.18
Note: We have evaluated all bandwidth and channels by modulation of QPSK and 16QAM, shown in the report are worst case.								

Product	Module	Test Site	AC-5
Test Item	Radiated Spurious Emission	Date of Test	2017/03/29
Test Mode	Mode1: LTE Band 2 Link QPSK/16QAM 10MHz	Test engineer	Scott

Frequency (MHz)	SA Reading (dBm)	Ant.Pol. (H/V)	SG Reading (dBm)	Cable Loss (dB)	Gain (dBi)	EIRP (dBm)	Limit (dBm)	Over Limit (dB)
Low Channel 18650 (1855MHz) BW10MHz 1RB0								
3710.00	-49.54	V	-64.50	4.78	12.76	-56.52	-13.00	-43.52
5565.00	-53.12	V	-59.52	4.87	13.22	-51.17	-13.00	-38.17
3710.00	-47.58	H	-64.60	4.81	12.78	-56.63	-13.00	-43.63
5565.00	-50.95	H	-62.28	4.86	13.17	-53.97	-13.00	-40.97
Middle Channel 18900 (1880.00MHz) BW10MHz 1RB0								
3760.00	-52.61	V	-65.53	5.03	12.72	-57.84	-13.00	-44.84
5640.00	-56.64	V	-61.71	5.93	13.14	-54.50	-13.00	-41.50
3760.00	-49.98	H	-65.41	5.03	12.72	-57.72	-13.00	-44.72
5640.00	-54.78	H	-61.32	5.93	13.14	-54.11	-13.00	-41.11
High Channel 19150 (1905.00MHz) BW10MHz 1RB0								
3810.00	-51.90	V	-65.86	5.06	12.72	-58.20	-13.00	-45.20
5715.00	-55.31	V	-63.04	4.85	13.14	-54.75	-13.00	-41.75
3810.00	-48.43	H	-65.36	4.97	12.75	-57.58	-13.00	-44.58
5715.00	-54.70	H	-61.90	4.88	13.12	-53.66	-13.00	-40.66
Note: We have evaluated all bandwidth and channels by modulation of QPSK and 16QAM, shown in the report are worst case.								

Product	Module	Test Site	AC-5
Test Item	Radiated Spurious Emission	Date of Test	2017/03/29
Test Mode	Mode1: LTE Band 2 Link QPSK/16QAM 5MHz	Test engineer	Scott

Frequency (MHz)	SA Reading (dBm)	Ant.Pol. (H/V)	SG Reading (dBm)	Cable Loss (dB)	Gain (dBi)	EIRP (dBm)	Limit (dBm)	Over Limit (dB)
Low Channel 18625 (1852.5MHz) BW5MHz 1RB0								
3705.00	-51.45	V	-60.10	4.76	12.73	-52.13	-13.00	-39.13
5557.50	-55.15	V	-59.44	4.81	13.20	-51.05	-13.00	-38.05
3705.00	-50.01	H	-65.04	4.83	12.73	-57.14	-13.00	-44.14
5557.50	-50.58	H	-62.79	4.87	13.18	-54.48	-13.00	-41.48
Middle Channel 18900 (1880.00MHz) BW5MHz 1RB0								
3760.00	-50.70	V	-64.00	5.03	12.72	-56.31	-13.00	-43.31
5640.00	-55.73	V	-60.52	5.93	13.14	-53.31	-13.00	-40.31
3760.00	-49.93	H	-65.60	5.03	12.72	-57.91	-13.00	-44.91
5640.00	-55.50	H	-60.18	5.93	13.14	-52.97	-13.00	-39.97
High Channel 19175 (1907.50MHz) BW5MHz 1RB0								
3815.00	-48.06	V	-65.92	5.01	12.80	-58.13	-13.00	-45.13
5722.50	-51.98	V	-62.36	4.84	13.13	-54.07	-13.00	-41.07
3815.00	-48.92	H	-66.07	5.04	12.81	-58.30	-13.00	-45.30
5722.50	-52.80	H	-62.63	4.88	13.12	-54.39	-13.00	-41.39
Note: We have evaluated all bandwidth and channels by modulation of QPSK and 16QAM, shown in the report are worst case.								

Product	Module	Test Site	AC-5
Test Item	Radiated Spurious Emission	Date of Test	2017/03/29
Test Mode	Mode1: LTE Band 2 Link QPSK/16QAM 3MHz	Test engineer	Scott

Frequency (MHz)	SA Reading (dBm)	Ant.Pol. (H/V)	SG Reading (dBm)	Cable Loss (dB)	Gain (dBi)	EIRP (dBm)	Limit (dBm)	Over Limit (dB)
-----------------	------------------	----------------	------------------	-----------------	------------	------------	-------------	-----------------

Low Channel 18615 (1851.5MHz) BW3MHz 1RB0

3703.00	-53.84	V	-61.77	4.81	12.75	-53.83	-13.00	-40.83
5554.50	-54.19	V	-61.53	4.84	13.22	-53.15	-13.00	-40.15
3703.00	-48.22	H	-64.83	4.79	12.80	-56.82	-13.00	-43.82
5554.50	-53.18	H	-62.28	4.80	13.24	-53.84	-13.00	-40.84

Middle Channel 18900 (1880.00MHz) BW3MHz 1RB0

3760.00	-48.68	V	-65.50	5.03	12.72	-57.81	-13.00	-44.81
5640.00	-54.12	V	-62.23	5.93	13.14	-55.02	-13.00	-42.02
3760.00	-47.10	H	-64.80	5.03	12.72	-57.11	-13.00	-44.11
5640.00	-55.45	H	-62.08	5.93	13.14	-54.87	-13.00	-41.87

High Channel 19185 (1908.50MHz) BW3MHz 1RB0

3817.00	-48.71	V	-65.71	5.03	12.79	-57.95	-13.00	-44.95
5725.50	-53.48	V	-63.31	4.85	13.17	-54.99	-13.00	-41.99
3817.00	-47.98	H	-65.15	5.02	12.78	-57.39	-13.00	-44.39
5725.50	-51.63	H	-61.42	4.86	13.12	-53.16	-13.00	-40.16

Note: We have evaluated all bandwidth and channels by modulation of QPSK and 16QAM, shown in the report are worst case.

Product	Module	Test Site	AC-5
Test Item	Radiated Spurious Emission	Date of Test	2017/03/29
Test Mode	Mode1: LTE Band 2 Link QPSK/16QAM 1.4MHz	Test engineer	Scott

Frequency (MHz)	SA Reading (dBm)	Ant.Pol. (H/V)	SG Reading (dBm)	Cable Loss (dB)	Gain (dBi)	EIRP (dBm)	Limit (dBm)	Over Limit (dB)
Low Channel 18607 (1850.70MHz) BW1.4MHz 1RB0								
3701.40	-50.72	V	-62.28	4.78	12.70	-54.36	-13.00	-41.36
5552.10	-54.76	V	-60.52	4.85	13.18	-52.19	-13.00	-39.19
3701.40	-50.09	H	-64.32	4.81	12.72	-56.41	-13.00	-43.41
5552.10	-51.81	H	-62.70	4.80	13.17	-54.33	-13.00	-41.33
Middle Channel 18900 (1880.00MHz) BW1.4MHz 1RB0								
3760.00	-50.84	V	-64.97	5.03	12.72	-57.28	-13.00	-44.28
5640.00	-54.15	V	-60.87	5.93	13.14	-53.66	-13.00	-40.66
3760.00	-48.76	H	-65.59	5.03	12.72	-57.90	-13.00	-44.90
5640.00	-54.41	H	-60.51	5.93	13.14	-53.30	-13.00	-40.30
High Channel 19193 (1909.30MHz) BW1.4MHz 1RB0								
3818.60	-48.33	V	-64.87	5.05	12.73	-57.19	-13.00	-44.19
5727.90	-54.14	V	-62.84	4.87	13.13	-54.58	-13.00	-41.58
3818.60	-46.89	H	-65.12	5.03	12.74	-57.41	-13.00	-44.41
5727.90	-51.82	H	-61.44	4.84	13.15	-53.13	-13.00	-40.13
Note: We have evaluated all bandwidth and channels by modulation of QPSK and 16QAM, shown in the report are worst case.								

Product	Module	Test Site	AC-5
Test Item	Radiated Spurious Emission	Date of Test	2017/03/29
Test Mode	Mode2: LTE Band 4 Link QPSK/16QAM 20MHz	Test engineer	Scott

Frequency (MHz)	SA Reading (dBm)	Ant.Pol. (H/V)	SG Reading (dBm)	Cable Loss (dB)	Gain (dBi)	EIRP (dBm)	Limit (dBm)	Over Limit (dB)
Low Channel 20050 (1720.00MHz) BW20MHz 1RB0								
3440.00	-53.85	V	-54.69	4.75	12.84	-46.60	-13.00	-33.60
5160.00	-57.02	V	-62.52	4.81	12.87	-54.46	-13.00	-41.46
3440.00	-51.90	H	-51.82	4.82	12.85	-43.79	-13.00	-30.79
5160.00	-54.82	H	-62.79	4.79	12.82	-54.76	-13.00	-41.76
Middle Channel 20175 (1732.50MHz) BW20MHz 1RB0								
3465.00	-55.59	V	-50.23	5.03	12.73	-42.53	-13.00	-29.53
5197.50	-56.43	V	-63.09	5.93	12.85	-56.17	-13.00	-43.17
3465.00	-51.20	H	-52.12	5.03	12.73	-44.42	-13.00	-31.42
5197.50	-56.27	H	-61.55	5.93	12.85	-54.63	-13.00	-41.63
High Channel 20300 (1745.00MHz) BW20MHz 1RB0								
3490.00	-55.13	V	-52.47	5.02	12.64	-44.85	-13.00	-31.85
5235.50	-55.72	V	-63.33	4.86	12.90	-55.29	-13.00	-42.29
3490.00	-51.71	H	-52.85	5.02	12.64	-45.23	-13.00	-32.23
5235.50	-55.95	H	-63.33	4.86	12.90	-55.29	-13.00	-42.29
Note: We have evaluated all bandwidth and channels by modulation of QPSK and 16QAM, shown in the report are worst case.								

Product	Module		
Test Item	Radiated Spurious Emission		
Test Mode	Mode 2: LTE Band 4 Link QPSK/16QAM 15MHz		
Date of Test	2017/04/01	Test Site	AC-5

Frequency (MHz)	SA Reading (dBm)	Ant.Pol. (H/V)	SG Reading (dBm)	Cable Loss (dB)	Gain (dBi)	EIRP (dBm)	Limit (dBm)	Over Limit (dB)
Low Channel 20025 (1717.50MHz) BW15MHz 1RB0								
3435.00	-54.78	V	-66.43	4.81	12.87	-58.37	-13.00	-45.37
5152.50	-55.23	V	-63.22	4.80	12.82	-55.20	-13.00	-42.20
3435.00	-52.45	H	-65.42	4.80	12.88	-57.34	-13.00	-44.34
5152.50	-57.52	H	-62.34	4.85	12.86	-54.33	-13.00	-41.33
Middle Channel 20175 (1732.50MHz) BW15MHz 1RB0								
3465.00	-57.03	V	-64.49	5.03	12.73	-56.79	-13.00	-43.79
5197.50	-56.79	V	-61.88	5.93	12.85	-54.96	-13.00	-41.96
3465.00	-52.97	H	-64.98	5.03	12.73	-57.28	-13.00	-44.28
5197.50	-58.04	H	-62.54	5.93	12.85	-55.62	-13.00	-42.62
High Channel 20325 (1747.50MHz) BW15MHz 1RB0								
3495.00	-53.86	V	-66.12	5.07	12.63	-58.56	-13.00	-45.56
5242.50	-54.99	V	-62.98	4.90	12.93	-54.95	-13.00	-41.95
3495.00	-52.15	H	-65.76	5.06	12.64	-58.18	-13.00	-45.18
5242.50	-56.42	H	-63.69	4.87	12.92	-55.64	-13.00	-42.64
Note: We have evaluated all bandwidth and channels by modulation of QPSK and 16QAM, shown in the report are worst case.								

Product	Module		
Test Item	Radiated Spurious Emission		
Test Mode	Mode 2: LTE Band 4 Link QPSK/16QAM 10MHz		
Date of Test	2017/04/01	Test Site	AC-5

Frequency (MHz)	SA Reading (dBm)	Ant.Pol. (H/V)	SG Reading (dBm)	Cable Loss (dB)	Gain (dBi)	EIRP (dBm)	Limit (dBm)	Over Limit (dB)
Low Channel 20000 (1715.00MHz) BW10MHz 1RB0								
3430.00	-56.23	V	-51.89	4.78	12.89	-43.78	-13.00	-30.78
5145.00	-55.56	V	-63.82	4.85	12.82	-55.85	-13.00	-42.85
3430.00	-56.68	H	-48.06	4.80	12.80	-40.06	-13.00	-27.06
5145.00	-56.99	H	-63.20	4.79	12.89	-55.10	-13.00	-42.10
Middle Channel 20175 (1732.50MHz) BW10MHz 1RB0								
3465.00	-56.58	V	-49.47	5.03	12.73	-41.77	-13.00	-28.77
5197.50	-55.61	V	-61.65	5.93	12.85	-54.73	-13.00	-41.73
3465.00	-55.60	H	-47.12	5.03	12.73	-39.42	-13.00	-26.42
5197.50	-54.86	H	-61.73	5.93	12.85	-54.81	-13.00	-41.81
High Channel 20325 (1750.00MHz) BW10MHz 1RB0								
3500.00	-58.56	V	-52.53	4.99	12.63	-44.89	-13.00	-31.89
5250.00	-58.34	V	-64.54	4.85	12.94	-56.45	-13.00	-43.45
3500.00	-54.91	H	-48.49	5.01	12.64	-40.86	-13.00	-27.86
5250.00	-55.46	H	-62.98	4.89	12.96	-54.91	-13.00	-41.91
Note: We have evaluated all bandwidth and channels by modulation of QPSK and 16QAM, shown in the report are worst case.								

Product	Module		
Test Item	Radiated Spurious Emission		
Test Mode	Mode 2: LTE Band 4 Link QPSK/16QAM 5MHz		
Date of Test	2017/04/01	Test Site	AC-5

Frequency (MHz)	SA Reading (dBm)	Ant.Pol. (H/V)	SG Reading (dBm)	Cable Loss (dB)	Gain (dBi)	EIRP (dBm)	Limit (dBm)	Over Limit (dB)
Low Channel 19975 (1712.50MHz) BW5MHz 1RB0								
3425.00	-49.74	V	-50.16	4.78	12.81	-42.13	-13.00	-29.13
5137.50	-50.08	V	-64.25	4.79	12.83	-56.21	-13.00	-43.21
3425.00	-47.03	H	-49.77	4.80	12.84	-41.73	-13.00	-28.73
5137.50	-50.06	H	-63.87	4.80	12.82	-55.85	-13.00	-42.85
Middle Channel 20175 (1732.50MHz) BW5MHz 1RB0								
3465.00	-56.59	V	-49.84	5.03	12.73	-42.14	-13.00	-29.14
5197.50	-56.05	V	-62.56	5.93	12.85	-55.64	-13.00	-42.64
3465.00	-55.99	H	-48.28	5.03	12.73	-40.58	-13.00	-27.58
5197.50	-54.27	H	-61.97	5.93	12.85	-55.05	-13.00	-42.05
High Channel 20375 (1752.50MHz) BW5MHz 1RB0								
3505.00	-55.64	V	-53.61	4.98	12.65	-45.94	-13.00	-32.94
5257.50	-54.27	V	-63.51	4.81	12.97	-55.35	-13.00	-42.35
3505.00	-56.27	H	-49.10	5.00	12.63	-41.47	-13.00	-28.47
5257.50	-56.69	H	-64.00	4.84	12.94	-55.90	-13.00	-42.90
Note: We have evaluated all bandwidth and channels by modulation of QPSK and 16QAM, shown in the report are worst case.								

Product	Module		
Test Item	Radiated Spurious Emission		
Test Mode	Mode 2: LTE Band 4 Link QPSK/16QAM 3MHz		
Date of Test	2017/04/01	Test Site	AC-5

Frequency (MHz)	SA Reading (dBm)	Ant.Pol. (H/V)	SG Reading (dBm)	Cable Loss (dB)	Gain (dBi)	EIRP (dBm)	Limit (dBm)	Over Limit (dB)
Low Channel 19965 (1711.50MHz) BW3MHz 1RB0								
3425.00	-53.78	V	-50.93	4.79	12.90	-42.82	-13.00	-29.82
5137.50	-52.63	V	-63.88	4.87	12.84	-55.91	-13.00	-42.91
3425.00	-53.19	H	-49.34	4.77	12.80	-41.31	-13.00	-28.31
5137.50	-52.41	H	-62.30	4.86	12.81	-54.35	-13.00	-41.35
Middle Channel 20175 (1732.50MHz) BW3MHz 1RB0								
3465.00	-53.87	V	-49.64	5.03	12.73	-41.94	-13.00	-28.94
5197.50	-54.16	V	-62.87	5.93	12.85	-55.95	-13.00	-42.95
3465.00	-54.38	H	-49.34	5.03	12.73	-41.64	-13.00	-28.64
5197.50	-53.87	H	-63.30	5.93	12.85	-56.38	-13.00	-43.38
High Channel 20385 (1753.50MHz) BW3MHz 1RB0								
3505.00	-55.91	V	-52.02	5.01	12.65	-44.38	-13.00	-31.38
5257.50	-55.48	V	-63.55	4.87	12.98	-55.44	-13.00	-42.44
3505.00	-54.06	H	-50.85	5.05	12.71	-43.19	-13.00	-30.19
5257.50	-56.85	H	-62.98	4.82	12.99	-54.81	-13.00	-41.81
Note: We have evaluated all bandwidth and channels by modulation of QPSK and 16QAM, shown in the report are worst case.								

Product	Module		
Test Item	Radiated Spurious Emission		
Test Mode	Mode 2: LTE Band 4 Link QPSK/16QAM 1.4MHz		
Date of Test	2017/04/01	Test Site	AC-5

Frequency (MHz)	SA Reading (dBm)	Ant.Pol. (H/V)	SG Reading (dBm)	Cable Loss (dB)	Gain (dBi)	EIRP (dBm)	Limit (dBm)	Over Limit (dB)
Low Channel 19957 (1710.70MHz) BW1.4MHz 1RB0								
3421.40	-54.58	V	-50.34	4.81	12.88	-42.27	-13.00	-29.27
5132.10	-56.79	V	-63.09	4.86	12.84	-55.11	-13.00	-42.11
3421.40	-52.16	H	-50.49	4.81	12.88	-42.42	-13.00	-29.42
5132.10	-56.03	H	-64.47	4.88	12.89	-56.46	-13.00	-43.46
Middle Channel 20175 (1732.50MHz) BW1.4MHz 1RB0								
3465.00	-54.54	V	-51.74	5.03	12.73	-44.04	-13.00	-31.04
5197.50	-54.76	V	-60.09	5.93	12.85	-53.17	-13.00	-40.17
3465.00	-54.02	H	-48.24	5.03	12.73	-40.54	-13.00	-27.54
5197.50	-52.24	H	-62.18	5.93	12.85	-55.26	-13.00	-42.26
High Channel 20393 (1754.30MHz) BW1.4MHz 1RB0								
3508.60	-55.14	V	-53.65	5.00	12.72	-45.93	-13.00	-32.93
5262.90	-55.54	V	-63.88	4.87	12.90	-55.85	-13.00	-42.85
3508.60	-54.37	H	-51.71	4.99	12.68	-44.02	-13.00	-31.02
5262.90	-54.81	H	-62.59	4.88	12.93	-54.54	-13.00	-41.54
Note: We have evaluated all bandwidth and channels by modulation of QPSK and 16QAM, shown in the report are worst case.								

Product	Module		
Test Item	Radiated Spurious Emission		
Test Mode	Mode 3: LTE Band 5 Link QPSK/16QAM 10MHz		
Date of Test	2017/04/01	Test Site	AC-5

Frequency (MHz)	SA Reading (dBm)	Ant.Pol. (H/V)	SG Reading (dBm)	Cable Loss (dB)	Gain (dBi)	EIRP (dBm)	Limit (dBm)	Over Limit (dB)
Low Channel 20450 (829MHz) BW10MHz 1RB0								
1658.00	-52.06	V	-40.72	3.31	9.76	-34.27	-13.00	-21.27
2487.00	-51.27	V	-51.41	4.13	10.49	-45.05	-13.00	-32.05
1658.00	-50.83	H	-45.43	3.31	9.76	-38.98	-13.00	-25.98
2487.00	-48.88	H	-52.67	4.13	10.49	-46.31	-13.00	-33.31
Middle Channel 20525 (836.5MHz) BW10MHz 1RB0								
1673.00	-54.90	V	-41.70	3.27	9.73	-35.24	-13.00	-22.24
2509.50	-54.81	V	-57.69	4.09	10.47	-51.31	-13.00	-38.31
1673.00	-54.60	H	-47.74	3.27	9.73	-41.28	-13.00	-28.28
2509.50	-50.16	H	-58.70	4.09	10.47	-52.32	-13.00	-39.32
High Channel 20600 (844MHz) BW10MHz 1RB0								
1688.00	-53.20	V	-39.13	3.29	10.06	-32.36	-13.00	-19.36
2532.00	-47.22	V	-59.51	4.08	10.31	-53.28	-13.00	-40.28
1688.00	-55.77	H	-45.39	3.29	10.06	-38.62	-13.00	-25.62
2532.00	-51.30	H	-57.80	4.08	10.31	-51.57	-13.00	-38.57
Note: We have evaluated all bandwidth and channels by modulation of QPSK and 16QAM, shown in the report are worst case.								

Product	Module		
Test Item	Radiated Spurious Emission		
Test Mode	Mode 3: LTE Band 5 Link QPSK/16QAM 5MHz		
Date of Test	2017/04/01	Test Site	AC-5

Frequency (MHz)	SA Reading (dBm)	Ant.Pol. (H/V)	SG Reading (dBm)	Cable Loss (dB)	Gain (dBi)	EIRP (dBm)	Limit (dBm)	Over Limit (dB)
Low Channel 20425 (826.5MHz) BW5MHz 1RB0								
1653.00	-55.81	V	-41.37	3.28	9.75	-34.90	-13.00	-21.90
2479.50	-50.26	V	-54.81	4.18	10.58	-48.41	-13.00	-35.41
1653.00	-55.42	H	-48.40	3.31	9.83	-41.88	-13.00	-28.88
2479.50	-54.37	H	-56.72	4.15	10.50	-50.37	-13.00	-37.37
Middle Channel 20525 (836.5MHz) BW5MHz 1RB0								
1673.00	-53.07	V	-41.11	3.27	9.73	-34.65	-13.00	-21.65
2509.50	-47.96	V	-54.73	4.09	10.47	-48.35	-13.00	-35.35
1673.00	-50.63	H	-47.86	3.27	9.73	-41.40	-13.00	-28.40
2509.50	-49.41	H	-56.08	4.09	10.47	-49.70	-13.00	-36.70
High Channel 20625 (846.5MHz) BW5MHz 1RB0								
1693.00	-53.36	V	-39.38	3.27	10.08	-32.57	-13.00	-19.57
2539.50	-50.48	V	-58.71	4.09	10.32	-52.48	-13.00	-39.48
1693.00	-51.04	H	-45.95	3.33	10.13	-39.15	-13.00	-26.15
2539.50	-49.00	H	-55.91	4.04	10.37	-49.58	-13.00	-36.58
Note: We have evaluated all bandwidth and channels by modulation of QPSK and 16QAM, shown in the report are worst case.								

Product	Module		
Test Item	Radiated Spurious Emission		
Test Mode	Mode 3: LTE Band 5 Link QPSK/16QAM 3MHz		
Date of Test	2017/04/01	Test Site	AC-5

Frequency (MHz)	SA Reading (dBm)	Ant.Pol. (H/V)	SG Reading (dBm)	Cable Loss (dB)	Gain (dBi)	EIRP (dBm)	Limit (dBm)	Over Limit (dB)
Low Channel 20415 (825.5MHz) BW3MHz 1RB0								
1651.00	-52.21	V	-42.28	3.30	9.84	-35.74	-13.00	-22.74
2476.50	-51.14	V	-57.50	4.09	10.50	-51.09	-13.00	-38.09
1651.00	-53.18	H	-49.29	3.30	9.78	-42.81	-13.00	-29.81
2476.50	-49.33	H	-52.80	4.18	10.54	-46.44	-13.00	-33.44
Middle Channel 20525 (836.5MHz) BW3MHz 1RB0								
1673.00	-54.16	V	-43.01	3.27	9.73	-36.55	-13.00	-23.55
2509.50	-49.52	V	-59.75	4.09	10.47	-53.37	-13.00	-40.37
1673.00	-52.48	H	-50.38	3.27	9.73	-43.92	-13.00	-30.92
2509.50	-50.91	H	-53.95	4.09	10.47	-47.57	-13.00	-34.57
High Channel 20635 (847.5MHz) BW3MHz 1RB0								
1695.00	-55.89	V	-41.83	3.26	10.14	-34.95	-13.00	-21.95
2542.50	-54.54	V	-57.27	4.08	10.39	-50.96	-13.00	-37.96
1695.00	-54.20	H	-48.70	3.31	10.09	-41.92	-13.00	-28.92
2542.50	-53.34	H	-57.32	4.04	10.39	-50.97	-13.00	-37.97
Note: We have evaluated all bandwidth and channels by modulation of QPSK and 16QAM, shown in the report are worst case.								

Product	Module		
Test Item	Radiated Spurious Emission		
Test Mode	Mode 3: LTE Band 5 Link QPSK/16QAM 1.4MHz		
Date of Test	2017/04/01	Test Site	AC-5

Frequency (MHz)	SA Reading (dBm)	Ant.Pol. (H/V)	SG Reading (dBm)	Cable Loss (dB)	Gain (dBi)	EIRP (dBm)	Limit (dBm)	Over Limit (dB)
Low Channel 20407 (824.7MHz) BW1.4MHz 1RB0								
1649.40	-54.90	V	-42.32	3.31	9.82	-35.81	-13.00	-22.81
2474.10	-54.88	V	-60.48	4.13	10.51	-54.10	-13.00	-41.10
1649.40	-55.57	H	-49.63	3.36	9.82	-43.17	-13.00	-30.17
2474.10	-54.58	H	-52.83	4.11	10.53	-46.41	-13.00	-33.41
Middle Channel 20525 (836.5MHz) BW1.4MHz 1RB0								
1673.00	-52.48	V	-43.41	3.27	9.73	-36.95	-13.00	-23.95
2509.50	-48.99	V	-61.56	4.09	10.47	-55.18	-13.00	-42.18
1673.00	-54.12	H	-50.82	3.27	9.73	-44.36	-13.00	-31.36
2509.50	-50.21	H	-58.12	4.09	10.47	-51.74	-13.00	-38.74
High Channel 20643 (848.3MHz) BW1.4MHz 1RB0								
1696.60	-55.90	V	-42.36	3.32	10.10	-35.58	-13.00	-22.58
2544.90	-56.04	V	-56.69	4.09	10.30	-50.48	-13.00	-37.48
1696.60	-54.42	H	-49.02	3.35	10.14	-42.23	-13.00	-29.23
2544.90	-56.22	H	-59.30	4.08	10.37	-53.01	-13.00	-40.01
Note: We have evaluated all bandwidth and channels by modulation of QPSK and 16QAM, shown in the report are worst case.								

Product	Module		
Test Item	Radiated Spurious Emission		
Test Mode	Mode 4: LTE Band 7 Link QPSK/16QAM20MHz		
Date of Test	2017/04/01	Test Site	AC-5

Frequency (MHz)	SA Reading (dBm)	Ant.Pol. (H/V)	SG Reading (dBm)	Cable Loss (dB)	Gain (dBi)	EIRP (dBm)	Limit (dBm)	Over Limit (dB)
Low Channel 20850 (2510.00MHz) BW20MHz 1RB0								
5020.00	-54.54	V	-67.86	1.24	12.67	-56.43	-25.00	-31.43
7530.00	-56.97	V	-63.15	1.50	11.30	-53.35	-25.00	-28.35
5020.00	-52.82	H	-65.91	1.24	12.67	-54.48	-25.00	-29.48
7530.00	-56.50	H	-61.58	1.50	11.30	-51.78	-25.00	-26.78
Middle Channel 21100 (2535.00MHz) BW20MHz 1RB0								
5070.00	-55.78	V	-68.98	1.22	12.72	-57.48	-25.00	-32.48
7605.00	-54.67	V	-64.43	1.54	11.45	-54.52	-25.00	-29.52
5070.00	-50.60	H	-66.26	1.22	12.72	-54.76	-25.00	-29.76
7605.00	-53.82	H	-60.81	1.54	11.45	-50.90	-25.00	-25.90
High Channel 21350 (2560.00MHz) BW20MHz 1RB0								
5120.00	-57.16	V	-68.91	1.21	12.78	-57.34	-25.00	-32.34
7680.00	-57.43	V	-64.86	1.57	11.45	-54.98	-25.00	-29.98
5120.00	-56.35	H	-67.55	1.21	12.78	-55.98	-25.00	-30.98
7680.00	-55.05	H	-60.81	1.57	11.45	-50.93	-25.00	-25.93
Note: We have evaluated all bandwidth and channels by modulation of QPSK and 16QAM, shown in the report are worst case.								

Product	Module		
Test Item	Radiated Spurious Emission		
Test Mode	Mode 4: LTE Band 7 Link QPSK/16QAM15MHz		
Date of Test	2017/04/01	Test Site	AC-5

Frequency (MHz)	SA Reading (dBm)	Ant.Pol. (H/V)	SG Reading (dBm)	Cable Loss (dB)	Gain (dBi)	EIRP (dBm)	Limit (dBm)	Over Limit (dB)
Low Channel 20825 (2507.50MHz) BW15MHz 1RB0								
5015.00	-50.40	V	-68.06	1.24	12.67	-56.63	-25.00	-31.63
7522.50	-56.73	V	-63.84	1.49	11.27	-54.06	-25.00	-29.06
5015.00	-53.93	H	-67.94	1.24	12.67	-56.51	-25.00	-31.51
7522.50	-56.35	H	-62.12	1.49	11.27	-52.34	-25.00	-27.34
Middle Channel 21100 (2535.00MHz)BW15MHz 1RB0								
5070.00	-57.96	V	-68.39	1.22	12.72	-56.89	-25.00	-31.89
7605.00	-56.82	V	-63.40	1.54	11.45	-53.49	-25.00	-28.49
5070.00	-54.83	H	-67.06	1.22	12.72	-55.56	-25.00	-30.56
7605.00	-56.43	H	-61.45	1.54	11.45	-51.54	-25.00	-26.54
High Channel 21375 (2562.50MHz) BW15MHz 1RB0								
5125.00	-52.87	V	-69.19	1.22	12.78	-57.63	-25.00	-32.63
7687.50	-57.42	V	-63.29	1.57	11.45	-53.41	-25.00	-28.41
5125.00	-57.09	H	-66.97	1.22	12.78	-55.41	-25.00	-30.41
7687.50	-56.88	H	-61.93	1.57	11.45	-52.05	-25.00	-27.05
Note: We have evaluated all bandwidth and channels by modulation of QPSK and 16QAM, shown in the report are worst case.								

Product	Module		
Test Item	Radiated Spurious Emission		
Test Mode	Mode 4: LTE Band 7 Link QPSK/16QAM10MHz		
Date of Test	2017/04/01	Test Site	AC-5

Frequency (MHz)	SA Reading (dBm)	Ant.Pol. (H/V)	SG Reading (dBm)	Cable Loss (dB)	Gain (dBi)	EIRP (dBm)	Limit (dBm)	Over Limit (dB)
Low Channel 20800 (2505.00MHz)BW10MHz1RB0								
5010.00	-55.23	V	-67.01	1.24	12.66	-55.59	-25.00	-30.59
7515.00	-55.60	V	-62.58	1.49	11.27	-52.80	-25.00	-27.80
5010.00	-53.78	H	-67.04	1.24	12.66	-55.62	-25.00	-30.62
7515.00	-54.94	H	-62.29	1.49	11.27	-52.51	-25.00	-27.51
Middle Channel 21100 (2535.00MHz) BW10MHz 1RB49								
5070.00	-56.25	V	-66.77	1.22	12.72	-55.27	-25.00	-30.27
7605.00	-56.33	V	-63.47	1.54	11.45	-53.56	-25.00	-28.56
5070.00	-51.97	H	-65.48	1.22	12.72	-53.98	-25.00	-28.98
7605.00	-54.13	H	-62.42	1.54	11.45	-52.51	-25.00	-27.51
High Channel 21400 (2565.00MHz) BW10MHz 1RB24								
5130.00	-54.58	V	-67.00	1.22	12.79	-55.43	-25.00	-30.43
7695.00	-56.05	V	-63.64	1.57	11.45	-53.76	-25.00	-28.76
5130.00	-55.51	H	-67.27	1.22	12.79	-55.70	-25.00	-30.70
7695.00	-57.71	H	-61.85	1.57	11.45	-51.97	-25.00	-26.97
Note: We have evaluated all bandwidth and channels by modulation of QPSK and 16QAM, shown in the report are worst case.								

Product	Module		
Test Item	Radiated Spurious Emission		
Test Mode	Mode 4: LTE Band 7 Link QPSK/16QAM5MHz		
Date of Test	2017/04/01	Test Site	AC-5

Frequency (MHz)	SA Reading (dBm)	Ant.Pol. (H/V)	SG Reading (dBm)	Cable Loss (dB)	Gain (dBi)	EIRP (dBm)	Limit (dBm)	Over Limit (dB)
Low Channel 20775 (2502.50MHz) BW5MHz 1RB0								
5005.00	-52.27	V	-67.08	1.24	12.65	-55.67	-25.00	-30.67
7507.50	-56.19	V	-63.22	1.48	11.25	-53.45	-25.00	-28.45
5005.00	-50.75	H	-66.54	1.24	12.65	-55.13	-25.00	-30.13
7507.50	-56.90	H	-62.30	1.48	11.25	-52.53	-25.00	-27.53
Middle Channel 21100 (2535.00MHz) BW5MHz 1RB0								
5070.00	-54.60	V	-66.72	1.22	12.72	-55.22	-25.00	-30.22
7605.00	-58.43	V	-63.25	1.54	11.45	-53.34	-25.00	-28.34
5070.00	-56.34	H	-66.10	1.22	12.72	-54.60	-25.00	-29.60
7605.00	-55.59	H	-62.98	1.54	11.45	-53.07	-25.00	-28.07
High Channel 21425 (2567.50MHz) BW5MHz 1RB0								
5135.00	-54.07	V	-67.02	1.22	12.79	-55.45	-25.00	-30.45
7702.50	-55.56	V	-62.63	1.57	11.45	-52.75	-25.00	-27.75
5135.00	-54.08	H	-65.86	1.22	12.79	-54.29	-25.00	-29.29
7702.50	-56.79	H	-61.12	1.57	11.45	-51.24	-25.00	-26.24
Note: We have evaluated all bandwidth and channels by modulation of QPSK and 16QAM, shown in the report are worst case.								

Product	Module		
Test Item	Radiated Spurious Emission		
Test Mode	Mode 5: LTE Band 12 Link QPSK/16QAM10MHz		
Date of Test	2017/04/01	Test Site	AC-5

Frequency (MHz)	SA Reading (dBm)	Ant.Pol. (H/V)	SG Reading (dBm)	Cable Loss (dB)	Gain (dBi)	EIRP (dBm)	Limit (dBm)	Over Limit (dB)
Low Channel 23060 (704MHz) BW10MHz 1RB0								
1408.00	-52.30	V	-63.94	2.78	8.06	-58.66	-13.00	-45.66
2112.00	-53.32	V	-66.00	3.97	9.49	-60.48	-13.00	-47.48
1408.00	-52.82	H	-65.04	2.78	8.06	-59.76	-13.00	-46.76
2112.00	-55.35	H	-63.48	3.97	9.49	-57.96	-13.00	-44.96
Middle Channel 23095 (707.5MHz) BW10MHz 1RB0								
1415.00	-53.70	V	-66.08	2.79	8.12	-60.75	-13.00	-47.75
2122.50	-53.35	V	-65.62	3.98	9.46	-60.14	-13.00	-47.14
1415.00	-51.43	H	-66.06	2.79	8.12	-60.73	-13.00	-47.73
2122.50	-54.67	H	-64.14	3.98	9.46	-58.66	-13.00	-45.66
High Channel 23255 (711MHz) BW10MHz 1RB0								
1422.00	-52.43	V	-66.27	2.81	8.18	-60.90	-13.00	-47.90
2133.50	-53.44	V	-64.53	3.99	9.43	-59.09	-13.00	-46.09
1422.00	-53.60	H	-66.76	2.81	8.18	-61.39	-13.00	-48.39
2133.50	-53.37	H	-64.62	3.99	9.43	-59.18	-13.00	-46.18
Note: We have evaluated all bandwidth and channels by modulation of QPSK and 16QAM, shown in the report are worst case.								

Product	Module		
Test Item	Radiated Spurious Emission		
Test Mode	Mode 5: LTE Band 12 Link QPSK/16QAM5MHz		
Date of Test	2017/04/01	Test Site	AC-5

Frequency (MHz)	SA Reading (dBm)	Ant.Pol. (H/V)	SG Reading (dBm)	Cable Loss (dB)	Gain (dBi)	EIRP (dBm)	Limit (dBm)	Over Limit (dB)
Low Channel 23035 (701.5MHz) BW5MHz 1RB0								
1403.00	-51.42	V	-56.95	2.78	8.03	-51.70	-13.00	-38.70
2104.50	-54.91	V	-65.83	3.97	9.51	-60.29	-13.00	-47.29
1403.00	-51.75	H	-65.07	2.78	8.03	-59.82	-13.00	-46.82
2104.50	-54.32	H	-65.27	3.97	9.51	-59.73	-13.00	-46.73
Middle Channel 23095 (707.5MHz) BW5MHz 1RB0								
1415.00	-53.88	V	-56.44	2.79	8.12	-51.11	-13.00	-38.11
2122.50	-52.36	V	-66.31	3.98	9.46	-60.83	-13.00	-47.83
1415.00	-52.32	H	-64.72	2.79	8.12	-59.39	-13.00	-46.39
2122.50	-54.05	H	-64.59	3.98	9.46	-59.11	-13.00	-46.11
High Channel 23155 (713.5MHz) BW5MHz 1RB0								
1427.00	-54.79	V	-57.89	2.81	8.22	-52.48	-13.00	-39.48
2140.50	-54.29	V	-65.49	3.99	9.41	-60.07	-13.00	-47.07
1427.00	-52.43	H	-65.35	2.81	8.22	-59.94	-13.00	-46.94
2140.50	-54.95	H	-65.27	3.99	9.41	-59.85	-13.00	-46.85
Note: We have evaluated all bandwidth and channels by modulation of QPSK and 16QAM, shown in the report are worst case.								

Product	Module		
Test Item	Radiated Spurious Emission		
Test Mode	Mode 5: LTE Band 12 Link QPSK/16QAM3MHz		
Date of Test	2017/04/01	Test Site	AC-5

Frequency (MHz)	SA Reading (dBm)	Ant.Pol. (H/V)	SG Reading (dBm)	Cable Loss (dB)	Gain (dBi)	EIRP (dBm)	Limit (dBm)	Over Limit (dB)
Low Channel 23025 (700.5MHz) BW3MHz 1RB0								
1414.00	-52.46	V	-58.92	2.78	8.11	-53.59	-13.00	-40.59
2114.50	-53.44	V	-65.38	3.97	9.48	-59.87	-13.00	-46.87
1414.00	-52.13	H	-65.34	2.78	8.11	-60.01	-13.00	-47.01
2114.50	-55.46	H	-64.07	3.97	9.48	-58.56	-13.00	-45.56
Middle Channel 23095 (707.5MHz) BW3MHz 1RB0								
1415.00	-53.11	V	-56.33	2.79	8.12	-51.00	-13.00	-38.00
2122.50	-54.28	V	-64.88	3.98	9.46	-59.40	-13.00	-46.40
1415.00	-51.19	H	-64.46	2.79	8.12	-59.13	-13.00	-46.13
2122.50	-52.64	H	-64.48	3.98	9.46	-59.00	-13.00	-46.00
High Channel 23165 (714.5MHz) BW3MHz 1RB0								
1429.00	-53.79	V	-55.25	2.81	8.24	-49.82	-13.00	-36.82
2143.50	-55.26	V	-64.49	3.99	9.40	-59.08	-13.00	-46.08
1429.00	-52.72	H	-65.48	2.81	8.24	-60.05	-13.00	-47.05
2143.50	-53.31	H	-64.03	3.99	9.40	-58.62	-13.00	-45.62
Note: We have evaluated all bandwidth and channels by modulation of QPSK and 16QAM, shown in the report are worst case.								

Product	Module		
Test Item	Radiated Spurious Emission		
Test Mode	Mode 5: LTE Band 12 Link QPSK/16QAM1.4MHz		
Date of Test	2017/04/01	Test Site	AC-5

Frequency (MHz)	SA Reading (dBm)	Ant.Pol. (H/V)	SG Reading (dBm)	Cable Loss (dB)	Gain (dBi)	EIRP (dBm)	Limit (dBm)	Over Limit (dB)
Low Channel 23017 (699.7MHz) BW1.4MHz 1RB0								
1399.40	-50.23	V	-56.43	2.78	8.01	-51.20	-13.00	-38.20
2099.10	-54.10	V	-65.37	3.97	9.55	-59.79	-13.00	-46.79
1399.40	-53.23	H	-65.18	2.78	8.01	-59.95	-13.00	-46.95
2099.10	-53.54	H	-63.86	3.97	9.55	-58.28	-13.00	-45.28
Middle Channel 23095 (707.5MHz) BW1.4MHz 1RB0								
1415.00	-54.07	V	-56.07	2.79	8.12	-50.74	-13.00	-37.74
2122.50	-54.20	V	-65.63	3.98	9.46	-60.15	-13.00	-47.15
1415.00	-53.89	H	-65.86	2.79	8.12	-60.53	-13.00	-47.53
2122.50	-52.94	H	-64.84	3.98	9.46	-59.36	-13.00	-46.36
High Channel 23173 (715.3MHz) BW1.4MHz 1RB0								
1430.60	-52.46	V	-51.99	2.79	8.25	-46.53	-13.00	-33.53
2145.90	-54.00	V	-63.77	3.98	9.40	-58.35	-13.00	-45.35
1430.60	-53.65	H	-64.06	2.79	8.25	-58.60	-13.00	-45.60
2145.90	-55.36	H	-64.44	3.98	9.40	-59.02	-13.00	-46.02
Note: We have evaluated all bandwidth and channels by modulation of QPSK and 16QAM, shown in the report are worst case.								

Product	Module		
Test Item	Radiated Spurious Emission		
Test Mode	Mode 6: LTE Band 13 Link QPSK/16QAM10MHz		
Date of Test	2017/04/01	Test Site	AC-5

Frequency (MHz)	SA Reading (dBm)	Ant.Pol. (H/V)	SG Reading (dBm)	Cable Loss (dB)	Gain (dBi)	EIRP (dBm)	Limit (dBm)	Over Limit (dB)
Middle Channel 23230 (782MHz) BW10MHz 1RB0								
1564.00	-53.95	V	-55.46	3.26	9.51	-49.21	-13.00	-36.21
2346.50	-52.89	V	-65.32	4.08	10.39	-59.01	-13.00	-46.01
1564.00	-52.32	H	-67.52	3.26	9.51	-61.27	-13.00	-48.27
2346.50	-55.74	H	-65.20	4.08	10.39	-58.89	-13.00	-45.89

Note: We have evaluated all bandwidth and channels by modulation of QPSK and 16QAM, shown in the report are worst case.

Product	Module		
Test Item	Radiated Spurious Emission		
Test Mode	Mode 6: LTE Band 13 Link QPSK/16QAM 5MHz		
Date of Test	2017/04/01	Test Site	AC-5

Frequency (MHz)	SA Reading (dBm)	Ant.Pol. (H/V)	SG Reading (dBm)	Cable Loss (dB)	Gain (dBi)	EIRP (dBm)	Limit (dBm)	Over Limit (dB)
Low Channel 23205 (779.5MHz) BW5MHz 1RB0								
1559.00	-53.90	V	-58.66	3.29	9.32	-52.63	-13.00	-39.63
2338.50	-54.08	V	-66.30	4.12	10.21	-60.21	-13.00	-47.21
1559.00	-52.33	H	-61.65	3.29	9.32	-55.62	-13.00	-42.62
2338.50	-55.41	H	-63.91	4.12	10.21	-57.82	-13.00	-44.82
Middle Channel 23230 (782MHz) BW5MHz 1RB0								
1564.00	-52.17	V	-57.12	3.26	9.51	-50.87	-13.00	-37.87
2346.50	-53.91	V	-66.44	4.08	10.39	-60.13	-13.00	-47.13
1564.00	-52.45	H	-61.22	3.26	9.51	-54.97	-13.00	-41.97
2346.50	-52.07	H	-64.25	4.08	10.39	-57.94	-13.00	-44.94
High Channel 23255 (784.5MHz) BW5MHz 1RB0								
1569.00	-52.70	V	-56.67	3.28	9.87	-50.08	-13.00	-37.08
2353.50	-54.43	V	-66.61	4.06	10.41	-60.26	-13.00	-47.26
1569.00	-51.60	H	-60.49	3.28	9.87	-53.90	-13.00	-40.90
2353.50	-52.71	H	-65.07	4.06	10.41	-58.72	-13.00	-45.72
Note: We have evaluated all bandwidth and channels by modulation of QPSK and 16QAM, shown in the report are worst case.								

Product	Module		
Test Item	Radiated Spurious Emission		
Test Mode	Mode 7: LTE Band 17 Link QPSK/16QAM10MHz		
Date of Test	2017/04/01	Test Site	AC-5

Frequency (MHz)	SA Reading (dBm)	Ant.Pol. (H/V)	SG Reading (dBm)	Cable Loss (dB)	Gain (dBi)	EIRP (dBm)	Limit (dBm)	Over Limit (dB)
Low Channel 23780 (709MHz) BW10MHz 1RB0								
1418.00	-53.09	V	-55.37	3.25	9.21	-49.41	-13.00	-36.41
2127.00	-52.94	V	-66.18	4.08	10.11	-60.15	-13.00	-47.15
1418.00	-51.91	H	-65.74	3.25	9.21	-59.78	-13.00	-46.78
2127.00	-53.63	H	-63.78	4.08	10.11	-57.75	-13.00	-44.75
Middle Channel 23790 (710MHz) BW10MHz 1RB0								
1420.00	-53.82	V	-55.24	3.25	9.21	-49.28	-13.00	-36.28
2130.00	-54.20	V	-65.73	4.08	10.11	-59.70	-13.00	-46.70
1420.00	-54.19	H	-66.62	3.25	9.21	-60.66	-13.00	-47.66
2130.00	-52.17	H	-65.19	4.08	10.11	-59.16	-13.00	-46.16
High Channel 23800 (711MHz) BW10MHz 1RB0								
1422.00	-52.64	V	-55.76	3.25	9.21	-49.80	-13.00	-36.80
2133.00	-53.82	V	-65.80	4.08	10.11	-59.77	-13.00	-46.77
1422.00	-52.72	H	-65.72	3.25	9.21	-59.76	-13.00	-46.76
2133.00	-52.85	H	-65.18	4.08	10.11	-59.15	-13.00	-46.15
Note: We have evaluated all bandwidth and channels by modulation of QPSK and 16QAM, shown in the report are worst case.								

Product	Module		
Test Item	Radiated Spurious Emission		
Test Mode	Mode 7: LTE Band 17 Link QPSK/16QAM 5MHz		
Date of Test	2017/04/01	Test Site	AC-5

Frequency (MHz)	SA Reading (dBm)	Ant.Pol. (H/V)	SG Reading (dBm)	Cable Loss (dB)	Gain (dBi)	EIRP (dBm)	Limit (dBm)	Over Limit (dB)
Low Channel 23755 (706.5MHz) BW5MHz 1RB0								
1413.00	-53.06	V	-56.13	3.29	9.25	-50.17	-13.00	-37.17
2119.50	-54.55	V	-65.77	4.12	10.11	-59.78	-13.00	-46.78
1413.00	-53.68	H	-64.23	3.23	9.20	-58.26	-13.00	-45.26
2119.50	-53.06	H	-63.88	4.13	10.10	-57.91	-13.00	-44.91
Middle Channel 23790 (710MHz) BW5MHz 1RB0								
1420.00	-53.42	V	-57.21	3.25	9.21	-51.25	-13.00	-38.25
2130.00	-54.30	V	-65.56	4.08	10.11	-59.53	-13.00	-46.53
1420.00	-52.28	H	-67.01	3.25	9.21	-61.05	-13.00	-48.05
2130.00	-53.81	H	-64.44	4.08	10.11	-58.41	-13.00	-45.41
High Channel 23825 (713.5MHz) BW5MHz 1RB0								
1427.00	-55.36	V	-57.05	3.30	9.29	-51.06	-13.00	-38.06
2140.50	-56.82	V	-66.36	4.12	10.18	-60.30	-13.00	-47.30
1427.00	-54.30	H	-66.01	3.29	9.21	-60.09	-13.00	-47.09
2140.50	-55.16	H	-65.18	4.09	10.12	-59.15	-13.00	-46.15
Note: We have evaluated all bandwidth and channels by modulation of QPSK and 16QAM, shown in the report are worst case.								

8. Frequency Stability Under Temperature & Voltage Variations

8.1. Test Equipment

Frequency Stability Under Temperature & Voltage Variations/TR-7				
Instrument	Manufacturer	Type No.	Serial No	Cali. Due Date
PSA Series Spectrum Analyzer	Agilent	E4440A	MY49420184	2018.02.04
Radio Communication Tester	Anritsu	MT8820C	6201181503	2017.09.16
Dual Directional Coupler	Agilent	778D	20160	2018.02.04
10dB Coaxial Coupler	Agilent	87300C	MY44300299	2018.03.28
DC Power Supply	IDRC	CD-035-020PR	977272	2017.09.16
Temperature & Humidity Chamber	Gaoyu	TH-1P-B	WIT-05121302	2017.01.04
Temperature/Humidity Meter	Zhicheng	ZC1-2	AC6-TH	2018.01.05

8.2. Test Setup

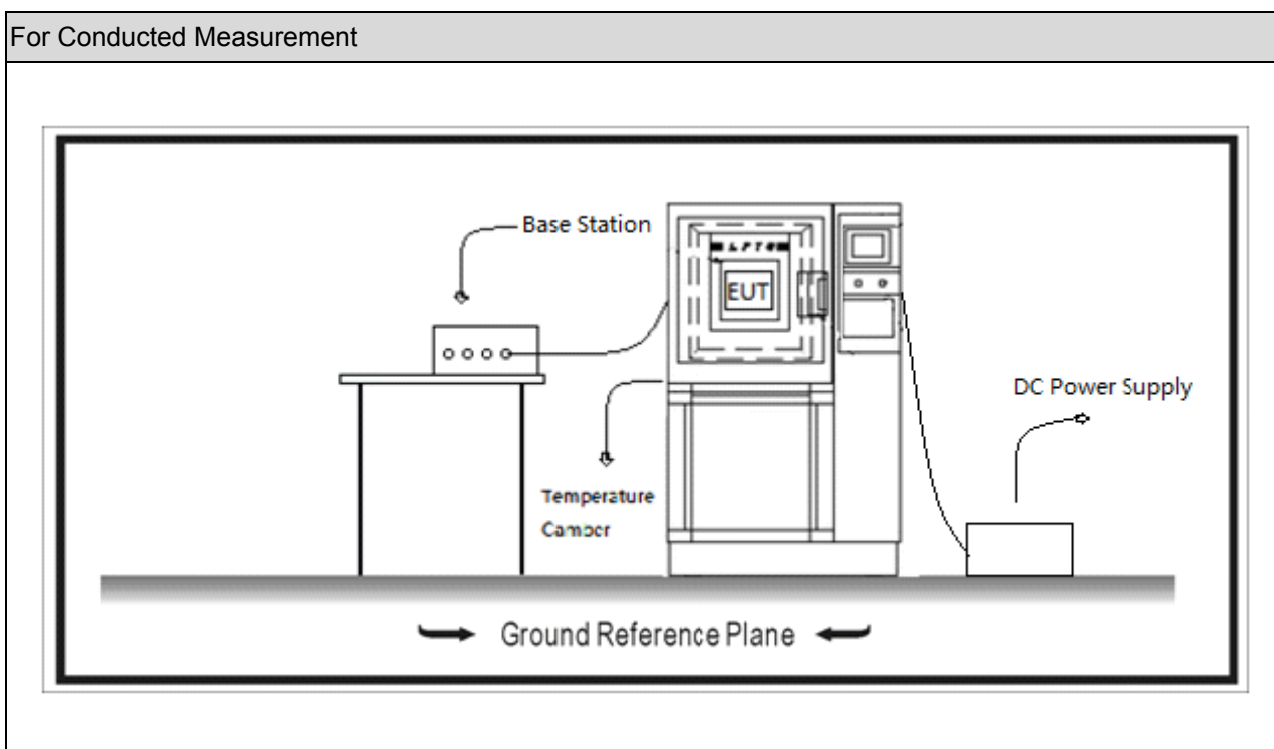

8.3. Test Procedure

Frequency Stability Under Temperature Variations:

The equipment under test was connected to an external AC or DC power supply and input rated voltage. RF output was connected to a frequency counter or spectrum analyzer via feed through attenuators. The EUT was placed inside the temperature chamber. Set the spectrum analyzer RBW low enough to obtain the desired frequency resolution and measure EUT 20°C operating frequency as reference frequency. Turn EUT off and set the chamber temperature to -30°C. After the temperature stabilized for approximately 30 minutes recorded the frequency. Repeat step measure with 10°C increased per stage until the highest temperature of +50°C reached.

Frequency Stability Under Voltage Variations:

Set chamber temperature to 20°C. Use a variable AC power supply / DC power source to power the EUT and set the voltage to rated voltage. Set the spectrum analyzer RBW low enough to obtain the desired frequency resolution and recorded the frequency.

Reduce the input voltage to specify extreme voltage variation ($\pm 15\%$) and endpoint, record the maximum frequency change.

8.4. Test Result

Product	Module		
Test Item	Frequency Stability Under Temperature & Voltage Variations		
Test Mode	Mode 1: LTE Band 2 Link(QPSK/16QAM)		
Date of Test	2016/12/03	Test Site	TR7

Frequency Stability under Temperature

Temperature Interval(°C)	Test Frequency (MHz)	Deviation (Hz)	Test Result
-30	1880	-21	PASS
-20	1880	22	PASS
-10	1880	-75	PASS
0	1880	61	PASS
10	1880	95	PASS
20	1880	77	PASS
30	1880	-56	PASS
40	1880	-21	PASS
50	1880	80	PASS

Frequency Stability under Voltage

DC Voltage (V)	Test Frequency (MHz)	Deviation (Hz)	Limit (Hz)
4.5	1880	-62	PASS
3.7	1880	-75	PASS
3.2	1880	43	PASS

Product	Module		
Test Item	Frequency Stability Under Temperature & Voltage Variations		
Test Mode	Mode 2: LTE Band 4 Link(QPSK/16QAM)		
Date of Test	2016/12/03	Test Site	TR7

Frequency Stability under Temperature

Temperature Interval(°C)	Test Frequency (MHz)	Deviation (Hz)	Test Result
-30	1732.50	9	PASS
-20	1732.50	4	PASS
-10	1732.50	54	PASS
0	1732.50	18	PASS
10	1732.50	-60	PASS
20	1732.50	-51	PASS
30	1732.50	-87	PASS
40	1732.50	40	PASS
50	1732.50	35	PASS

Frequency Stability under Voltage

DC Voltage (V)	Test Frequency (MHz)	Deviation (Hz)	Test Result
4.5	1732.50	17	PASS
3.7	1732.50	56	PASS
3.2	1732.50	33	PASS

Product	Module		
Test Item	Frequency Stability Under Temperature & Voltage Variations		
Test Mode	Mode 3: LTE Band 5 Link(QPSK/16QAM)		
Date of Test	2016/12/03	Test Site	TR7

Frequency Stability under Temperature

Temperature Interval(°C)	Test Frequency (MHz)	Deviation (Hz)	Test Result
-30	836.5	80	PASS
-20	836.5	40	PASS
-10	836.5	-57	PASS
0	836.5	89	PASS
10	836.5	1	PASS
20	836.5	49	PASS
30	836.5	92	PASS
40	836.5	-64	PASS
50	836.5	69	PASS

Frequency Stability under Voltage

DC Voltage (V)	Test Frequency (MHz)	Deviation (Hz)	Limit (Hz)
4.5	836.5	-5	PASS
3.7	836.5	27	PASS
3.2	836.5	23	PASS

Product	Module		
Test Item	Frequency Stability Under Temperature & Voltage Variations		
Test Mode	Mode 4: LTE Band 7 Link(QPSK/16QAM)		
Date of Test	2016/12/03	Test Site	TR7

Frequency Stability under Temperature

Temperature Interval(°C)	Test Frequency (MHz)	Deviation (Hz)	Test Result
-30	2535	46	PASS
-20	2535	88	PASS
-10	2535	0	PASS
0	2535	-91	PASS
10	2535	-63	PASS
20	2535	-8	PASS
30	2535	90	PASS
40	2535	-55	PASS
50	2535	-95	PASS

Frequency Stability under Voltage

DC Voltage (V)	Test Frequency (MHz)	Deviation (Hz)	Test Result
4.5	2535	-26	PASS
3.7	2535	-15	PASS
3.2	2535	-29	PASS

Product	Module		
Test Item	Frequency Stability Under Temperature & Voltage Variations		
Test Mode	Mode 5: LTE Band 12 Link(QPSK/16QAM)		
Date of Test	2016/12/03	Test Site	TR7

Frequency Stability under Temperature

Temperature Interval(°C)	Test Frequency (MHz)	Deviation (Hz)	Test Result
-30	707.5	-14	PASS
-20	707.5	27	PASS
-10	707.5	-89	PASS
0	707.5	-26	PASS
10	707.5	69	PASS
20	707.5	-22	PASS
30	707.5	39	PASS
40	707.5	28	PASS
50	707.5	-72	PASS

Frequency Stability under Voltage

DC Voltage (V)	Test Frequency (MHz)	Deviation (Hz)	Test Result
4.5	707.5	53	PASS
3.7	707.5	85	PASS
3.2	707.5	67	PASS

Product	Module		
Test Item	Frequency Stability Under Temperature & Voltage Variations		
Test Mode	Mode 6: LTE Band 13 Link(QPSK/16QAM)		
Date of Test	2016/12/07	Test Site	TR7

Frequency Stability under Temperature

Temperature Interval(°C)	Test Frequency (MHz)	Deviation (Hz)	Test Result
-30	782	42	PASS
-20	782	41	PASS
-10	782	-67	PASS
0	782	-70	PASS
10	782	33	PASS
20	782	-5	PASS
30	782	37	PASS
40	782	29	PASS
50	782	69	PASS

Frequency Stability under Voltage

DC Voltage (V)	Test Frequency (MHz)	Deviation (Hz)	Test Result
4.5	782	-73	PASS
3.7	782	7	PASS
3.2	782	-35	PASS

Product	Module		
Test Item	Frequency Stability Under Temperature & Voltage Variations		
Test Mode	Mode 7: LTE Band 17 Link(QPSK/16QAM)		
Date of Test	2016/12/07	Test Site	TR7

Frequency Stability under Temperature

Temperature Interval(°C)	Test Frequency (MHz)	Deviation (Hz)	Test Result
-30	710	58	PASS
-20	710	1	PASS
-10	710	-2	PASS
0	710	46	PASS
10	710	-39	PASS
20	710	20	PASS
30	710	-17	PASS
40	710	84	PASS
50	710	-34	PASS

Frequency Stability under Voltage

DC Voltage (V)	Test Frequency (MHz)	Deviation (Hz)	Test Result
4.5	710	-72	PASS
3.7	710	-50	PASS
3.2	710	4	PASS

————— The End —————