

FCC Part22H&24E&90S Test Report

Product Name : Wireless Module
Model No. : AR7558
FCC ID : N7NAR7558
IC : 2417C-AR7558

Applicant : Sierra Wireless Inc.

Address : 13811 Wireless Way Richmond, British Columbia,
Canada, V6V 3A4.

Date of Receipt : Jan. 14, 2015
Test Date : Jan. 14, 2015~ Feb. 02, 2015
Issued Date : Feb. 11, 2015
Report No. : 1510280R-HP-US-P07V03
Report Version : V 1.0



The test results relate only to the samples tested.

The test results shown in the test report are traceable to the national/international standard through the calibration of the equipment and evaluated measurement uncertainty herein.

This report must not be used to claim product endorsement by TAF or any agency of the government.

The test report shall not be reproduced without the written approval of QuieTek Corporation.

Test Report Certification

Issued Date : Feb. 11, 2015

Report No. : 1510280R-HP-US-P07V03



Product Name : Wireless Module
Applicant : Sierra Wireless Inc.
Address : 13811 Wireless Way Richmond, British Columbia, Canada,
V6V 3A4.
Manufacturer : Sierra Wireless Inc.
Address : 13811 Wireless Way Richmond, British Columbia, Canada,
V6V 3A4.
Model No. : AR7558
FCC ID : N7NAR7558
IC : 2417C-AR7558
EUT Voltage : Low: 3.4V, High: 4.2V, Normal: 3.7V
Brand Name : AirPrime
Applicable Standard : FCC CFR Title 47 Part 2, TIA/EIA 603-C
FCC Part22 Subpart H, FCC Part24 Subpart E
FCC Part90 Subpart S
Industry Canada RSS-132, Issue 3
Industry Canada RSS-133, Issue 6
Test Result : Complied
Performed Location : Suzhou EMC Laboratory
No.99 Hongye Rd., Suzhou Industrial Park Loufeng Hi-Tech
Development Zone., Suzhou, China
TEL: +86-512-6251-5088 / FAX: +86-512-6251-5098
FCC Registration Number: 800392

Documented By : Alice Ni
Reviewed By : Dream Cao
Approved By : Jeff Chen

Laboratory Information

We, **Quietek Corporation**, are an independent EMC and safety consultancy that was established the whole facility in our laboratories. The test facility has been accredited/accepted(audited or listed) by the following related bodies in compliance with ISO 17025, EN 45001 and specified testing scope:

Taiwan R.O.C.	:	BSMI, NCC, TAF
Germany	:	TUV Rheinland
Norway	:	Nemko, DNV
USA	:	FCC
Japan	:	VCCI
China	:	CNAS

The related certificate for our laboratories about the test site and management system can be downloaded from Quietek Corporation's Web Site :<http://www.quietek.com/tw/ctg/cts/accreditations.htm>

The address and introduction of Quietek Corporation's laboratories can be founded in our Web site :
<http://www.quietek.com/>

If you have any comments, Please don't hesitate to contact us. Our contact information is as below:

HsinChu Testing Laboratory :

No.75-2, 3rd Lin, Wangye Keng, Yongxing Tsuen, Qionglin Shiang, Hsinchu County 307, Taiwan, R.O.C.
TEL:+886-3-592-8858 / FAX:+886-3-592-8859 E-Mail : service@quietek.com

LinKou Testing Laboratory :

No.5-22, Ruishukeng, Linkou Dist., New Taipei City 24451, Taiwan, R.O.C.
TEL : 886-2-8601-3788 / FAX : 886-2-8601-3789 E-Mail : service@quietek.com

Suzhou Testing Laboratory :

No.99 Hongye Rd., Suzhou Industrial Park Loufeng Hi-Tech Development Zone., SuZhou, China
TEL : +86-512-6251-5088 / FAX : 86-512-6251-5098 E-Mail : service@quietek.com

TABLE OF CONTENTS

Description	Page
1. General Information	7
1.1. EUT Description	7
1.2. Mode of Operation	9
1.3. Tested System Details	10
1.4. Configuration of Tested System	11
1.5. EUT Exercise Software	12
2. Technical Test	13
2.1. Summary of Test Result	13
2.2. Test Environment	16
3. Maximum Output Power and Effective Isotropic Radiated Power Measurement	17
3.1. Test Equipment	17
3.2. Test Setup	18
3.3. Test Procedure	18
3.4. Uncertainty	21
3.5. Test Result	22
4. Modulation Characteristic	28
4.1. Test Equipment	28
4.2. Test Setup	28
4.3. Uncertainty	28
4.4. Test Result	28
5. Occupied Bandwidth	29
5.1. Test Equipment	29
5.2. Test Setup	29
5.3. Test Procedure	29
5.4. Uncertainty	29
5.5. Test Result	30
6. Conducted Band Edge	48
6.1. Test Equipment	48
6.2. Test Setup	48
6.3. Test Procedure	48
6.4. Uncertainty	49
6.5. Test Result	50
7. Spurious Emission	62
7.1. Test Equipment	62
7.2. Test Setup	63
7.3. Test Procedure	65

7.4. Uncertainty	65
7.5. Test Result.....	66
8. Frequency Stability Under Temperature & Voltage Variations.....	102
8.1. Test Equipment.....	102
8.2. Test Setup.....	102
8.3. Test Procedure	103
8.4. Uncertainty	103
8.5. Test Result.....	104

History of This Test Report

REPORT NO.	VERSION	DESCRIPTION	ISSUED DATE
1510280R-HP-US-P07V03	V1.0	Initial Issued Report	Feb. 11, 2015

1. General Information

1.1. EUT Description

Product Name	Wireless Module
Model No.	AR7558
Brand Name	AirPrime
EUT Voltage	Low: 3.4V, High: 4.2V, Normal: 3.7V
2G	
Support Band	GSM850/PCS1900
GPRS Class	Class 12
Uplink	GSM 850: 824~849MHz PCS 1900: 1850~1910MHz
Downlink	GSM 850: 869~894MHz PCS 1900: 1930~1990MHz
Type of modulation	GMSK for GPRS; 8PSK for EDGE
Antenna Type	Dipole
Antenna Gain	GSM 850: 1.2dBi PCS1900: 1.3dBi
CDMA	
Support Band	BC0/BC1/BC10
Uplink	BC0: 824~849MHz BC1: 1850~1910MHz BC10:809~824MHz
Downlink	BC0: 869~894MHz BC1: 1930~1990MHz BC10: 854~869MHz
Type of Modulation	QPSK
Antenna Type	Dipole
Peak Antenna Gain	BC0: 1.2dBi BC1: 1.3dBi BC10: 1.2dBi
3G	
Support Band	WCDMA Band 2/WCDMA Band 5
Uplink	WCDMA Band 2: 1850~1910MHz WCDMA Band 5: 824~849MHz
Downlink	WCDMA Band 2: 1930~1990MHz

	WCDMA Band 5: 869~894MHz
Type of modulation	QPSK for Uplink
Antenna Type	Dipole
Antenna Gain	Band 2: 1.3dBi Band 5: 1.2dBi
1XEVD0	
Support Band	BC0/BC1
Uplink	BC0: 824~849MHz BC1: 1850~1910MHz BC10:809~824MHz
Downlink	BC0: 869~894MHz BC1: 1930~1990MHz BC10: 854~869MHz
Release Version	Rel-A
Type of Modulation	QPSK
Antenna Type	Dipole
Peak Antenna Gain	BC0: 1.2dBi BC1: 1.3dBi BC10: 1.2dBi
4G	
Support Band	LTE Band 4/25/26/41
Uplink	Band 4: 1710~1755MHz Band 25: 1850~1915MHz Band 26: 814~849MHz Band 41: 2496~2690MHz
Downlink	Band 4: 2110~2155MHz Band 25: 1930~1995MHz Band 26: 859~894MHz Band 41: 2496~2690MHz
Type of modulation	QPSK, 16QAM
Antenna Type	Dipole
Antenna Gain	Band 4: 1.3dBi Band 25: 1.3dBi Band 26: 1.2dBi Band 41: 4.2dBi

1.2. Mode of Operation

QuieTek has verified the construction and function in typical operation. All the test modes were carried out with the EUT in normal operation, which was shown in this test report and defined as:

Test Mode
Mode 1: CDMA 2000 1X BC0 Link
Mode 2: CDMA 2000 1X BC1 Link
Mode 3: CDMA 2000 1X BC10 Link
Mode 4: CDMA 2000 1XEVD0 BC0 Rel-0 Link
Mode 5: CDMA 2000 1XEVD0 BC1 Rel-0 Link
Mode 6: CDMA 2000 1XEVD0 BC10 Rel-0 Link
Mode 7: CDMA 2000 1XEVD0 BC0 Rel-A Link
Mode 8: CDMA 2000 1XEVD0 BC1 Rel-A Link
Mode 9: CDMA 2000 1XEVD0 BC10 Rel-A Link

Note:

1. Regards to the frequency band operation: the lowest, middle and highest frequency of channel were selected to perform the test, then shown on this report.

1.3. Tested System Details

The types for all equipments, plus descriptions of all cables used in the tested system (including inserted cards) are:

Product		Manufacturer	Model No.	Serial No.	Power Cord
1	CMU200	R&S	CMU200	N/A	N/A

1.4. Configuration of Tested System

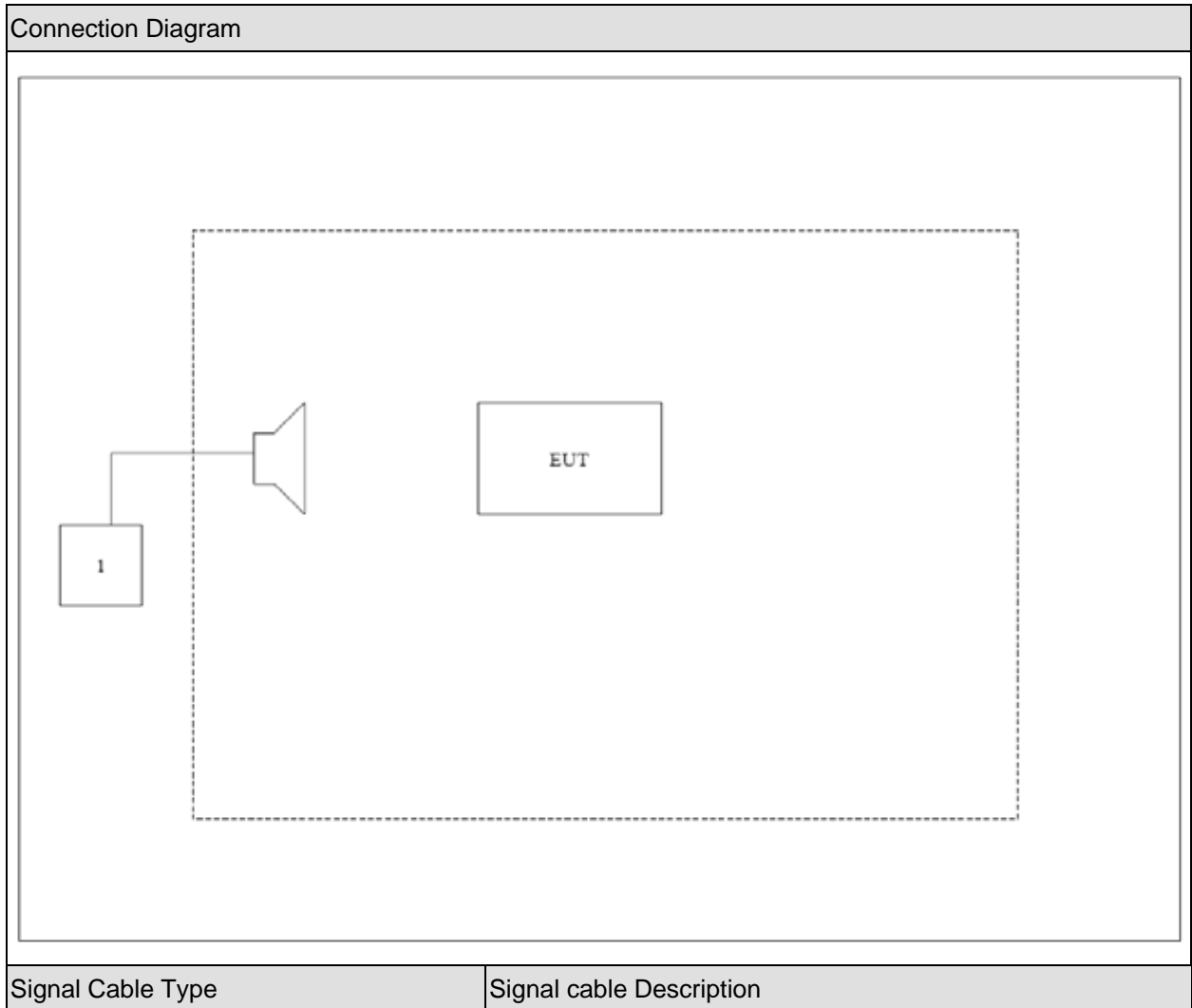

1.5. EUT Exercise Software

1	Setup the EUT and simulators as shown on above.
2	Turn on the power of all equipment.
3	EUT Communicate with CMU200, then select channel to test.

2. Technical Test

2.1. Summary of Test Result

- No deviations from the test standards
- Deviations from the test standards as below description:

**For CDMA 2000 1X BC0/CDMA 2000 1XEVD0 BC0
(FCC Part 22 Subpart H & Part 2, Industry Canada RSS-132, Issue 3, Industry Canada RSS-GEN)**

Performed Item	FCC Rule	IC Rule	Limit	Result
Maximum Output Power	§2.1033 §2.1046 §22.913	§5.4	< 7 Watts	Pass
Equivalent Isotropic Radiated Power	§22.913	§5.4	< 7 Watts	Pass
Modulation characteristics	§2.1047	§5.2	N/A	Pass
Occupied Bandwidth	§2.1049	RSS-GEN §4.2	N/A	Pass
Conducted Band Edge Emissions	§22.917	§5.5	< -13dBm	Pass
Field Strength of Spurious Radiation	§2.1053 §22.917	§5.5	< -13dBm	Pass
Frequency Stability Under Temperature & Voltage Variations	§2.1055 §22.335	§5.3	< 2.5 ppm	Pass

**For CDMA 2000 1X BC1/ CDMA 2000 1XEVD0 BC1
 (FCC Part 24 Subpart E & Part 2, Industry Canada RSS-133, Issue 6, Industry Canada
 RSS-GEN)**

Performed Item	FCC Rule	IC Rule	Limit	Result
Maximum Output Power	§2.1033 §2.1046 §24.232	§6.4	< 2 Watts	Pass
Equivalent Isotropic Radiated Power	§24.232	§6,4	< 2 Watts	Pass
Modulation characteristics	§2.1047	§6.2	N/A	Pass
Occupied Bandwidth	§2.1049	RSS-GEN §4.2	N/A	Pass
Conducted Band Edge Emissions	§27.238	§6.5	< -13dBm	Pass
Field Strength of Spurious Radiation	§2.1053 §24.238	§6.5	< -13dBm	Pass
Frequency Stability Under Temperature & Voltage Variations	§2.1055 §24.235	§6.3	< 2.5 ppm	Pass

**For CDMA 2000 1X BC10/CDMA 2000 1XEVD0 BC10
(FCC Part 90 Subpart S & Part 2)**

Performed Item	FCC Rule	Limit	Result
Maximum Output Power	§2.1033	< 100 Watts	Pass
	§2.1046		
	§90.635		
Equivalent Isotropic Radiated Power	§90.635	< 100 Watts	Pass
Modulation characteristics	§2.1047	N/A	Pass
Occupied Bandwidth	§2.1049	N/A	Pass
Conducted Band Edge Emissions	§90.691	< - 20dBm	Pass
Field Strength of Spurious Radiation	§2.1053	< -13dBm	Pass
	§90.691		
Frequency Stability Under Temperature & Voltage Variations	§2.1055 §90.231	< 2.5 ppm	Pass

2.2. Test Environment

Items	Required (IEC 68-1)	Actual
Temperature (°C)	15-35	23
Humidity (%RH)	25-75	52
Barometric pressure (mbar)	860-1060	950-1000

3. Maximum Output Power and Effective Isotropic Radiated Power Measurement

3.1. Test Equipment

Peak Conducted Output Power / AC-6

Instrument	Manufacturer	Type No.	Serial No	Cali. Due Date
PSA Series Spectrum Analyzer	Agilent	E4440A	MY49420184	2015.03.28
Radio Communication Tester	R&S	CMU 200	117088	2015.03.28
Dual Directional Coupler	Agilent	778D	20160	2015.03.28
10dB Coaxial Coupler	Agilent	87300C	MY44300299	2015.03.28
Temperature/Humidity Meter	Zhicheng	ZC1-2	AC6-TH	2016.01.07

Peak Radiated Output Power / AC-5

Instrument	Manufacturer	Type No.	Serial No	Cali. Due Date
Radio Communication Tester	R&S	CMU 200	117088	2015.03.28
Preamplifier	Miteq	NSP1800-25	1364185	2015.05.03
Preamplifier	Quietek	AP-040G	CHM-0906001	2015.05.03
Bilog Antenna	Teseq GmbH	CBL6112D	27612	2015.10.15
DRG Horn	ETS-Lindgren	3117	00123988	2016.01.07
Broad-Band Horn Antenna	Schwarzbeck	BBHA9120D	737	2015.03.01
Coaxial Cable	Huber+Suhner	SUCOFLEX 106	AC5-C1	2015.03.01
Coaxial Cable	Huber+Suhner	SUCOFLEX 106	AC5-C2	2015.03.01
Coaxial Cable	Huber+Suhner	SUCOFLEX 102	AC5-C3	2015.08.07
EMI Receiver	Agilent	N9038A	MY51210196	2016.01.07
Temperature/Humidity Meter	Zhichen	ZC1-2	AC5-TH	2015.03.30

3.2. Test Setup

Conducted Power Measurement:

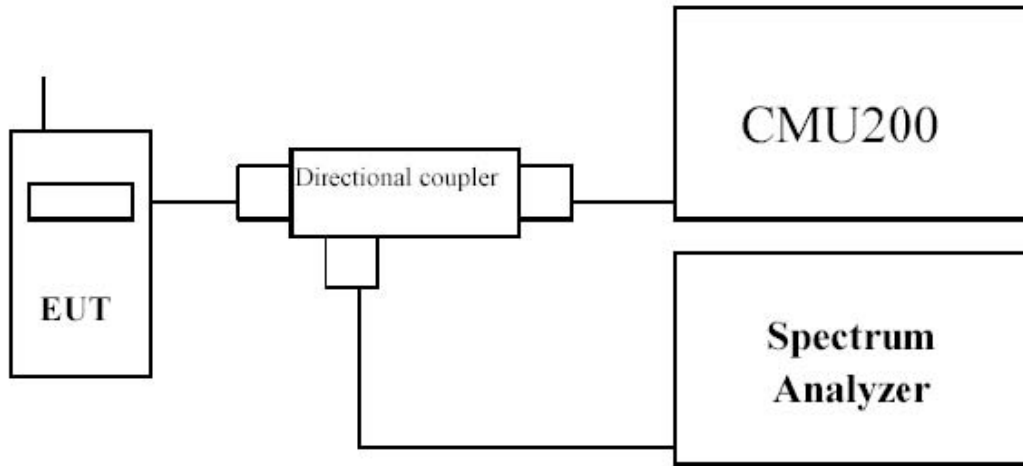

Radiated Power Measurement:

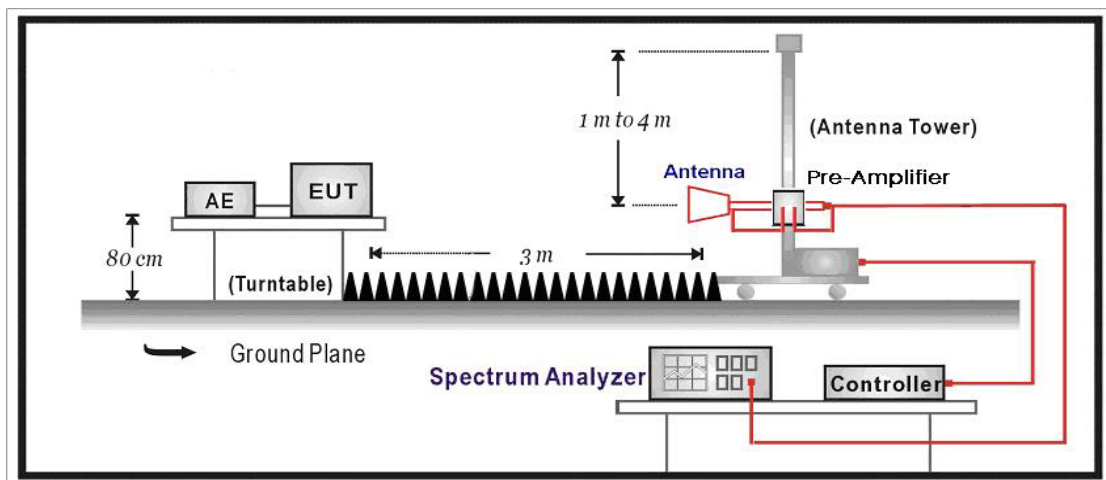

3.3. Test Procedure

For Conducted Power Measurement:

- a) The RF output of the transmitter was connected to base station simulator.
- b) The RF output of EUT was connected to the spectrum analyzer by RF cable and attenuator. The path loss was compensated to the results for each measurement..
- c) Set EUT at maximum average power by base station simulator.
- d) Measure lowest, middle, and highest channels for each bandwidth and different modulation.

For Effective Isotropic Radiated Power Measurement:

Radiated Power Measurement:

- a) The EUT shall be placed at the specified height on a support, and in the position closest to normal use as declared by provider.
- b) The test antenna shall be oriented initially for vertical polarization and shall be chosen to correspond to the frequency of the transmitter
- c) The output of the test antenna shall be connected to the measuring receiver.
- d) The transmitter shall be switched on and the measuring receiver shall be tuned to the frequency of the transmitter under test.
- e) The test antenna shall be raised and lowered through the specified range of height until a maximum signal level is detected by the measuring receiver.
- f) The transmitter shall then be rotated through 360° in the horizontal plane, until the maximum signal level is detected by the measuring receiver.
- g) The test antenna shall be raised and lowered again through the specified range of height until a maximum signal level is detected by the measuring receiver.
- h) The maximum signal level detected by the measuring receiver shall be noted.
- i) The transmitter shall be replaced by a substitution antenna.
- j) The substitution antenna shall be orientated for vertical polarization and the length of the substitution antenna shall be adjusted to correspond to the frequency of the transmitter.
- k) The substitution antenna shall be connected to a calibrated signal generator.
- l) If necessary, the input attenuator setting of the measuring receiver shall be adjusted in order to increase the sensitivity of the measuring receiver.
- m) The test antenna shall be raised and lowered through the specified range of height to ensure that the maximum signal is received.
- n) The input signal to the substitution antenna shall be adjusted to the level that produces a level detected by the measuring receiver, that is equal to the level noted while the transmitter radiated power was measured, corrected for the change of input attenuator setting of the measuring receiver.
- o) The measurement shall be repeated with the test antenna and the substitution antenna orientated for horizontal polarization.
- p) The measure of the effective radiated power is the larger of the two levels recorded at the input to the substitution antenna, corrected for gain of the substitution antenna if necessary.
 - q) Test site anechoic chamber refer to ANSI C63.4: 2009.

Base station simulator settings for each test mode:

1. For 1xRTT

Use CDMA2000 Rev 6 protocol in R&S CMU200.

1) Test for Reverse/Forward TCH RC1, Reverse/Forward TCH RC2, and RC3 Reverse FCH and demodulation of RC 3, 4 and 5.

a. Set up a call using Fundamental Channel Test Mode 1 (RC1, SO 2) with 9600 bps data rate only.

b. As per C.S0011 or TIA/EIA-98-F Table 4.4.5.2-1, set the test parameters as shown in Table 4-1.

c. Send continuously '0' power control bits to the Gobi2000 Module.

d. Measure the output power at Gobi2000 Module antenna connector as recorded on the power meter with values corrected for cables losses.

e. Repeat step b through d for Fundamental Channel Test Mode:

i. RC1, SO55

ii. RC2, SO9

iii. RC2, SO55

iv. RC3, SO55

2) Test for RC 3 Reverse FCH, RC3 Reverse SCH0 and demodulation of RC 3, 4 and 5.

a. Set up a call using Supplemental Channel Test Mode 3 (RC 3, SO 32) with 9600 bps Fundamental Channel and 9600 bps SCH0 data rate.

b. As per C.S0011 or TIA/EIA-98-F Table 4.4.5.2-2, set the test parameters as shown in Table 4-2.

c. Send alternating '0' and '1' power control bit to the Gobi2000 Module

d. Determine the active channel configuration. If the desired channel configuration is not the active channel configuration, increase $\hat{\rho}$ by 1 dB and repeat the verification. Repeat this step until the desired channel configuration becomes active.

e. Measure the output power at the Gobi2000 Module antenna connector.

f. Decrease $\hat{\rho}$ by 0.5 dB.

g. Determine the active channel configuration. If the active channel configuration is the desired channel configuration, measure the output power at the Gobi2000 Module antenna connector.

h. Repeat step f and g until the output power no longer increases or the desired channel configuration is no longer active. Record the highest output power achieved with the desired channel configuration active.

i. Repeat step a through h ten times and average the result.

Table 4-1 Parameters for Max. Power with a single traffic code channel, SR1

Parameter	Units	Value
\hat{I}_{or}	dBm/1.23 MHz	-104
(Pilot Ec) / Ior	dB	-7
(Traffic Ec) / Ior	dB	-7.4

Table 4-2 Parameters for Max. Power with multiple traffic code channel, SR1

Parameter	Units	Value
(Pilot Ec) / Ior	dB	-7
(Traffic Ec) / Ior	dB	-7.4

3.4. Uncertainty

The measurement uncertainty is defined as for Conducted Power Measurement ± 1.2 dB, for Radiated Power Measurement ± 3.2 dB

3.5. Test Result

Product	Wireless Module		
Test Item	Maximum Output Power		
Date of Test	2015/01/14	Test Site	TR-8

Mode	Test Case			BC0 (850MHz) Channel		
	Num.	FWD RC/TAP	REV RC/TAP	Conducted Power (dBm)		
				1013	384	777
1x	1	RC1	RC1 (SO2)	23.15	23.26	23.36
	2	RC1	RC1 (SO55)	23.30	23.36	23.45
	3	RC2	RC2 (SO9)	23.09	23.26	23.41
	4	RC2	RC2 (SO55)	23.02	23.34	23.45
	5	RC3	RC3 (SO55)	23.11	23.29	23.40
	6	RC3	RC3 (SO32)	23.28	23.38	23.39
1x EV-DO Rel0	7a	FTAP rate = 307kbps (2 slot, QPSK)	RTAP rate = 9.6kbps	22.71	22.75	22.85
	7b		RTAP rate = 19.2kbps	22.69	22.78	22.81
	7c		RTAP rate = 38.4kbps	22.71	22.76	22.88
	7d		RTAP rate = 76.8kbps	22.70	22.77	22.87
	7e		RTAP rate = 153.6kbps	22.72	22.79	22.90
1x EV-DO Rev A	8a	FETAP rate = 307kbps (2 slot, ACK channel is transmitted at all the slots)	RETAP – payload size = 128	22.72	22.95	23.13
	8b		RETAP – payload size = 256	22.73	22.93	23.12
	8c		RETAP – payload size = 512	22.76	22.92	23.11
	8d		RETAP – payload size = 768	22.79	22.88	23.09
	8e		RETAP – payload size = 1024	22.81	22.99	23.10
	8f		RETAP – payload size = 1536	22.87	22.89	23.15
	8g		RETAP – payload size = 2048	22.88	22.90	23.19
	8h		RETAP – payload size = 3072	22.79	22.93	23.13
	8i		RETAP – payload size = 4096	22.81	22.92	23.15
	8j		RETAP – payload size = 6144	22.86	22.99	23.14
	8k		RETAP – payload size = 8192	22.89	23.00	23.20
8l	RETAP – payload size = 12288	22.90	23.01	23.22		

Mode	Test Case			BC1 (1900MHz) Channel		
	Num.	FWD RC/TAP	REV RC/TAP	Conducted Power (dBm)		
				25	600	1175
1x	1	RC1	RC1 (SO2)	22.82	23.01	23.21
	2	RC1	RC1 (SO55)	22.85	23.03	23.12
	3	RC2	RC2 (SO9)	22.78	22.83	23.02
	4	RC2	RC2 (SO55)	22.72	22.91	23.27
	5	RC3	RC3 (SO55)	22.69	22.81	23.01
	6	RC3	RC3 (SO32)	22.68	22.85	23.17
1x EV-DO Rel0	7a	FTAP rate = 307kbps (2 slot, QPSK)	RTAP rate = 9.6kbps	22.23	22.35	22.63
	7b		RTAP rate = 19.2kbps	22.32	22.38	22.59
	7c		RTAP rate = 38.4kbps	22.45	22.59	22.66
	7d		RTAP rate = 76.8kbps	22.38	22.76	22.95
	7e		RTAP rate = 153.6kbps	22.77	22.90	23.05
1x EV-DO Rev A	8a	FETAP rate = 307kbps (2 slot, ACK channel is transmitted at all the slots)	RETAP – payload size = 128	22.53	22.76	22.98
	8b		RETAP – payload size = 256	22.49	22.76	22.94
	8c		RETAP – payload size = 512	22.59	22.77	22.89
	8d		RETAP – payload size = 768	22.56	22.61	22.71
	8e		RETAP – payload size = 1024	22.58	22.94	23.01
	8f		RETAP – payload size = 1536	22.61	22.71	22.89
	8g		RETAP – payload size = 2048	22.57	22.84	22.99
	8h		RETAP – payload size = 3072	22.49	22.57	22.61
	8i		RETAP – payload size = 4096	22.56	22.62	22.76
	8j		RETAP – payload size = 6144	22.53	22.72	22.67
	8k		RETAP – payload size = 8192	22.59	22.61	22.88
8l	RETAP – payload size = 12288	22.62	22.77	22.74		

Note: All conducted measurements are based on an average detector.

Mode	Test Case			BC10 (800MHz) Channel		
	Num.	FWD RC/TAP	REV RC/TAP	Conducted Power (dBm)		
				476	580	684
1x	1	RC1	RC1 (SO2)	23.32	23.34	23.38
	2	RC1	RC1 (SO55)	23.31	23.33	23.35
	3	RC2	RC2 (SO9)	23.28	23.32	23.37
	4	RC2	RC2 (SO55)	23.29	23.31	23.35
	5	RC3	RC3 (SO55)	23.28	23.32	23.36
	6	RC3	RC3 (SO32)	23.21	23.26	23.30
1x EV-DO Rel0	7a	FTAP rate = 307kbps (2 slot, QPSK)	RTAP rate = 9.6kbps	22.46	22.57	22.61
	7b		RTAP rate = 19.2kbps	22.64	22.67	22.71
	7c		RTAP rate = 38.4kbps	22.56	22.58	22.61
	7d		RTAP rate = 76.8kbps	22.49	22.52	22.59
	7e		RTAP rate = 153.6kbps	22.51	22.55	22.61
1x EV-DO Rev A	8a	FETAP rate = 307kbps (2 slot, ACK channel is transmitted at all the slots)	RETAP – payload size = 128	22.41	22.44	22.48
	8b		RETAP – payload size = 256	22.39	22.41	22.45
	8c		RETAP – payload size = 512	22.40	22.43	22.47
	8d		RETAP – payload size = 768	22.38	22.41	22.43
	8e		RETAP – payload size = 1024	22.41	22.42	22.45
	8f		RETAP – payload size = 1536	22.35	22.39	22.43
	8g		RETAP – payload size = 2048	22.38	22.42	22.47
	8h		RETAP – payload size = 3072	22.41	22.47	22.51
	8i		RETAP – payload size = 4096	22.33	22.36	22.43
	8j		RETAP – payload size = 6144	22.29	22.31	22.38
	8k		RETAP – payload size = 8192	22.44	22.46	22.52
8l	RETAP – payload size = 12288	22.36	22.41	22.51		

Note: All conducted measurements are based on an average detector.

Product	Wireless Module		
Test Item	Effective Isotropic Radiated Power		
Date of Test	2015/01/14	Test Site	AC-5

Radiated Power EIRP/ERP				
Band	Modulation	Freq. (MHz)	EIRP (dBm)	H/V
CDMA 2000 1X BC0	GMSK	824.70	21.63	H
		836.52	21.83	H
		848.31	21.77	H
		824.70	24.05	V
		836.52	24.18	V
		848.31	24.33	V
CDMA 2000 1X BC1	GMSK	1851.25	21.71	H
		1880.00	21.89	H
		1908.75	21.94	H
		1851.25	24.27	V
		1880.00	24.39	V
		1908.75	24.41	V
CDMA 2000 1X BC10	GMSK	817.90	22.49	H
		820.50	22.58	H
		823.10	22.64	H
		817.90	24.21	V
		820.50	24.34	V
		823.10	24.37	V
CDMA 2000 1X EVDO Rel-0 BC0	QPSK	824.70	21.09	H
		836.52	21.17	H
		848.31	21.24	H
		824.70	23.98	V
		836.52	24.01	V

		848.31	24.13	V
CDMA 2000 1X EVDO Rel-0 BC1	QPSK	1851.25	21.16	H
		1880.00	21.28	H
		1908.75	21.43	H
		1851.25	23.95	V
		1880.00	24.08	V
		1908.75	24.11	V
CDMA 2000 1X EVDO Rel-0 BC10	QPSK	817.90	21.23	H
		820.50	21.28	H
		823.10	21.21	H
		817.90	23.21	V
		820.50	23.39	V
		823.10	23.47	V
CDMA 2000 1X EVDO Rel-A	QPSK	824.70	20.65	H
		836.52	20.73	H
		848.31	20.80	H
		824.70	23.68	V
		836.52	23.71	V
		848.31	23.80	V
CDMA 2000 1X EVDO Rel-A	QPSK	1851.25	20.72	H
		1880.00	20.84	H
		1908.75	20.99	H
		1851.25	23.77	V
		1880.00	23.85	V
		1908.75	23.91	V
CDMA 2000 1X EVDO Rel-A BC10	QPSK	817.90	21.47	H
		820.50	21.65	H
		823.10	21.89	H
		817.90	23.76	V

		820.50	23.88	V
		823.10	23.96	V

4. Modulation Characteristic

4.1. Test Equipment

Modulation Characteristic / AC-6

Instrument	Manufacturer	Type No.	Serial No	Cali. Due Date
PSA Series Spectrum Analyzer	Agilent	E4440A	MY49420184	2015.03.28
Radio Communication Tester	R&S	CMU 200	117088	2015.03.28
Dual Directional Coupler	Agilent	778D	20160	2015.03.28
10dB Coaxial Coupler	Agilent	87300C	MY44300299	2015.03.28
Temperature/Humidity Meter	Zhicheng	ZC1-2	AC6-TH	2016.01.07

4.2. Test Setup

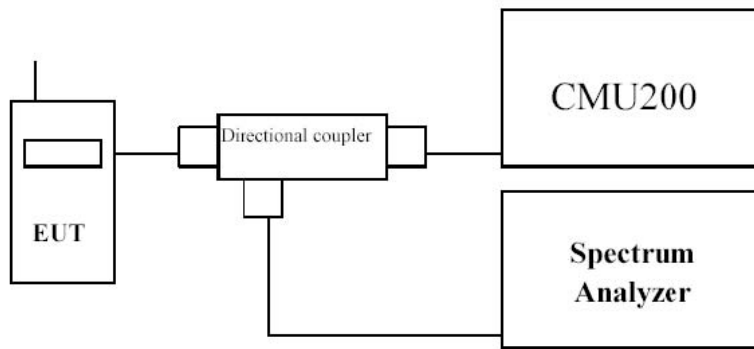

4.3. Uncertainty

The measurement uncertainty is defined as 0.1%

4.4. Test Result

The modulation of CDMA was verified and confirmed compliance with requirement.

5. Occupied Bandwidth

5.1. Test Equipment

Occupied Bandwidth / AC-6

Instrument	Manufacturer	Type No.	Serial No	Cali. Due Date
PSA Series Spectrum Analyzer	Agilent	E4440A	MY49420184	2015.03.28
Radio Communication Tester	R&S	CMU 200	117088	2015.03.28
Dual Directional Coupler	Agilent	778D	20160	2015.03.28
10dB Coaxial Coupler	Agilent	87300C	MY44300299	2015.03.28
Temperature/Humidity Meter	Zhicheng	ZC1-2	AC6-TH	2016.01.07

5.2. Test Setup

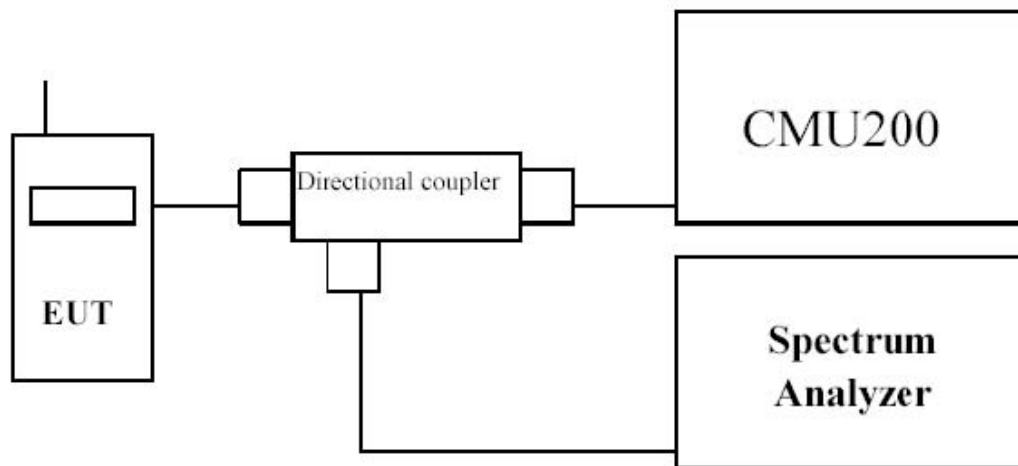

5.3. Test Procedure

1. The EUT was connected to Spectrum Analyzer and Base Station via power divider.
2. The RF output of EUT was connected to the spectrum analyzer by RF cable and attenuator. The path loss was compensated to the results for each measurement.
3. The 99% occupied bandwidth and 26 dB bandwidth of the low & middle & high channel for the highest RF powers were measured.

5.4. Uncertainty

The measurement uncertainty is defined as ± 10 Hz

5.5. Test Result

Product	Wireless Module		
Test Item	Occupied Bandwidth		
Test Mode	Mode 1: CDMA 2000 1X BC0 Link		
Date of Test	2015/01/15	Test Site	AC-6

Channel No.	Frequency (MHz)	-26dB Occupied Bandwidth (kHz)	99% Occupied Bandwidth (kHz)
1013	824.70	1423.00	1272.90
384	836.52	1418.00	1271.60
777	848.31	1415.00	1271.50

Figure Channel 1013 (824.70MHz)

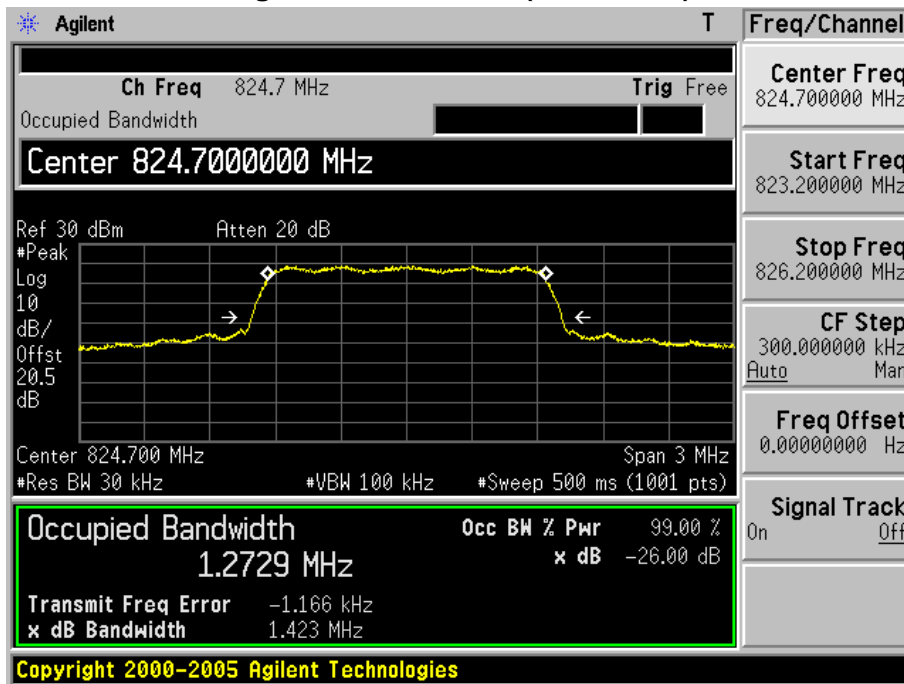

Figure Channel 384 (836.52MHz)

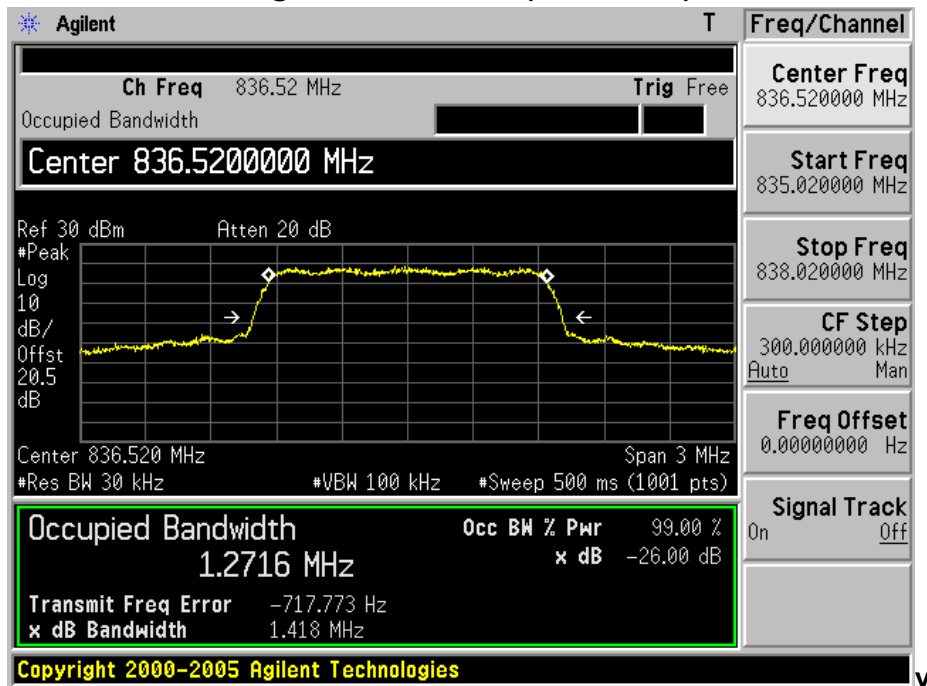
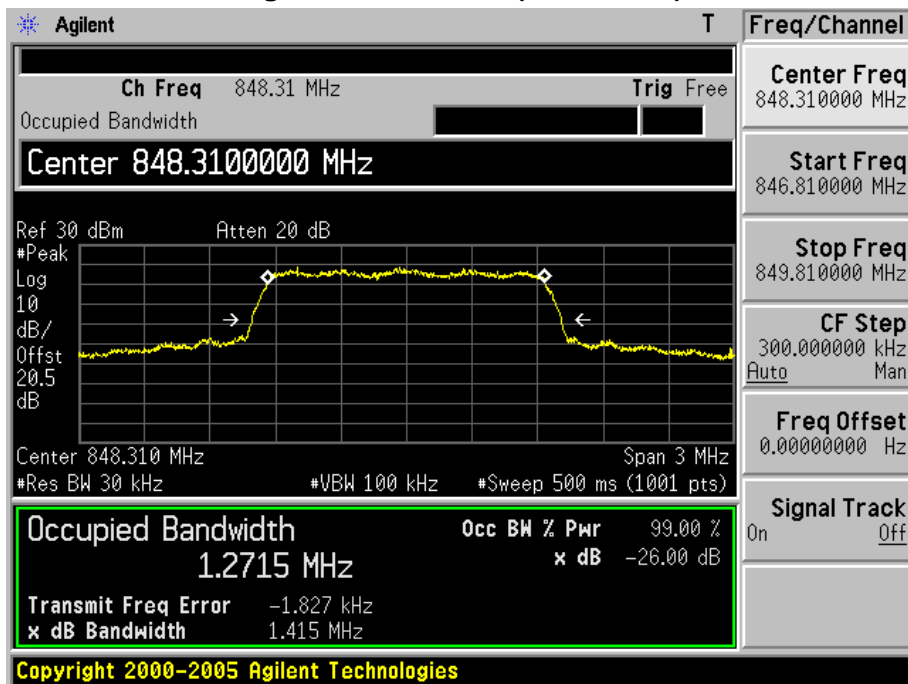

Figure Channel 777 (848.31MHz)



Product	Wireless Module		
Test Item	Occupied Bandwidth		
Test Mode	Mode 2: CDMA 2000 1X BC1 Link		
Date of Test	2015/01/15	Test Site	AC-6

Channel No.	Frequency (MHz)	-26dB Occupied Bandwidth (kHz)	99% Occupied Bandwidth (kHz)
25	1851.25	1441.00	1276.80
600	1880.00	1415.00	1273.70
1175	1908.75	1430.00	1274.80

Figure Channel 25 (1851.25MHz)

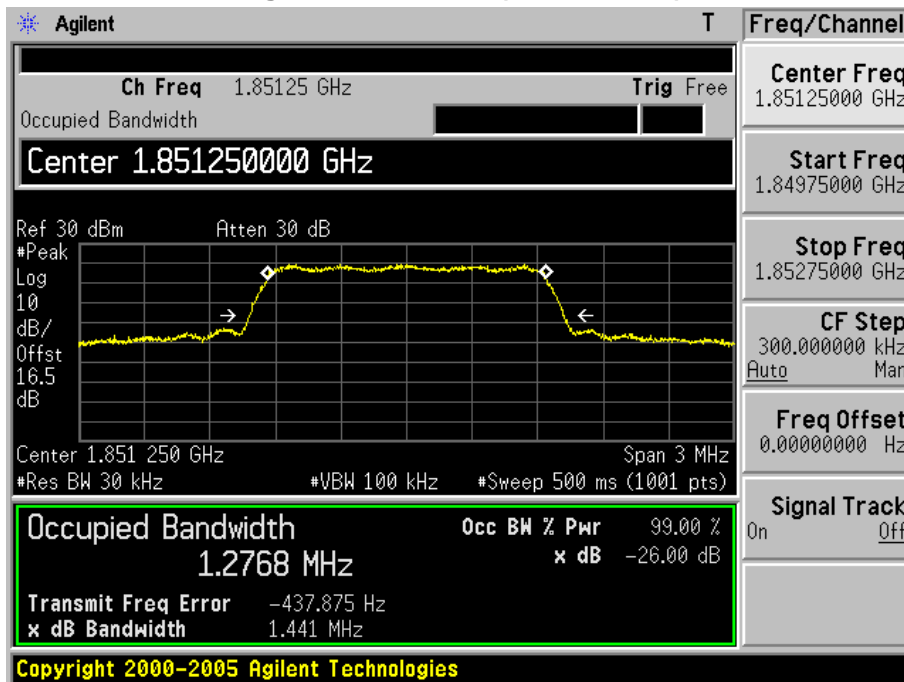

Figure Channel 600 (1880MHz)

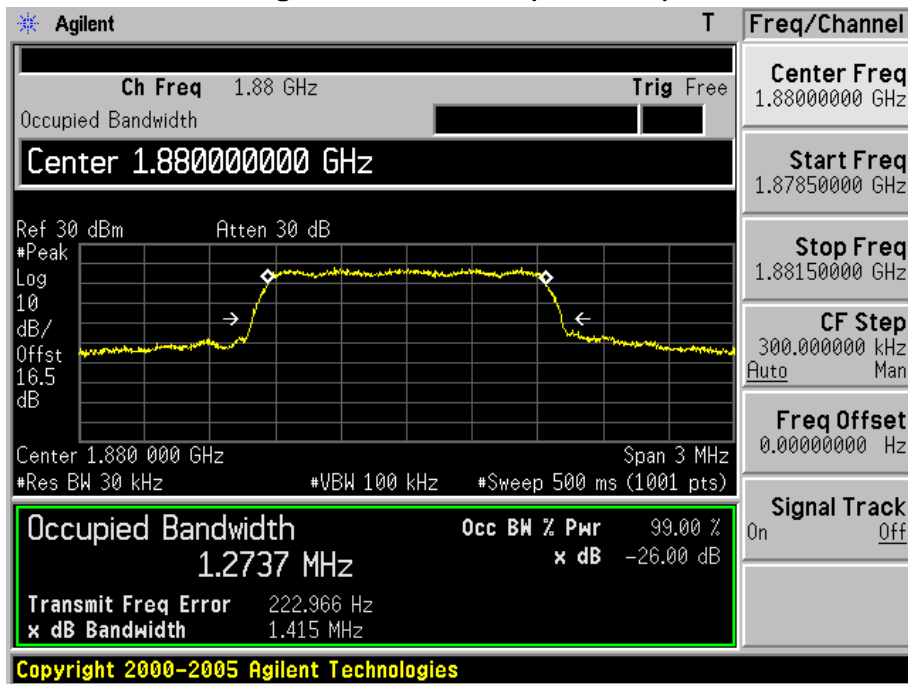
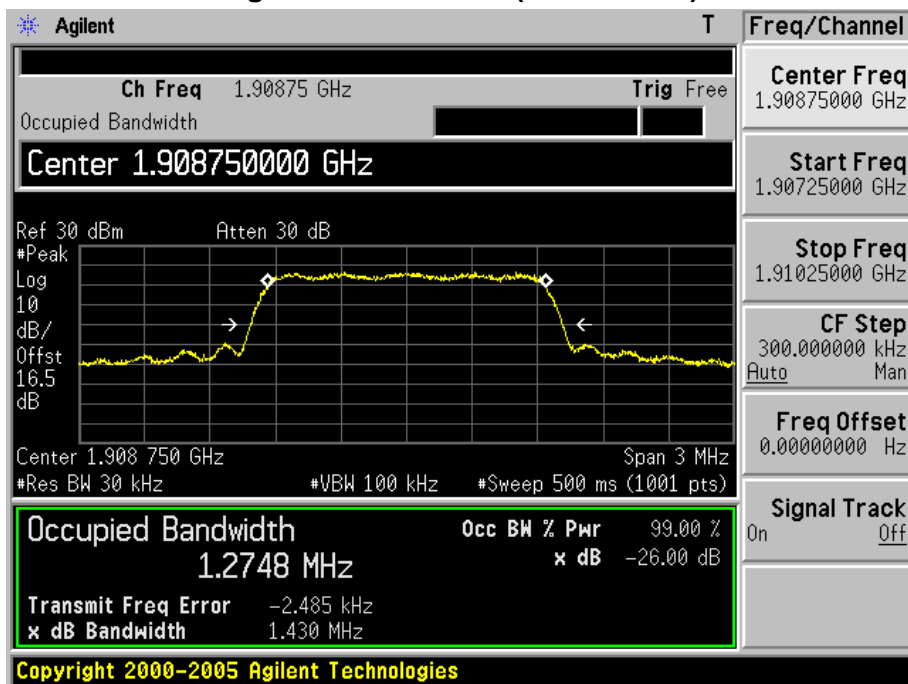

Figure Channel 1175 (1908.75MHz)



Product	Wireless Module		
Test Item	Occupied Bandwidth		
Test Mode	Mode 3: CDMA 2000 1X BC10 Link		
Date of Test	2015/02/09	Test Site	AC-6

Channel No.	Frequency (MHz)	-26dB Occupied Bandwidth (kHz)	99% Occupied Bandwidth (kHz)
476	817.90	1417.00	1272.20
580	820.50	1419.00	1271.90
684	823.10	1420.00	1270.90

Figure Channel 476 (817.90MHz)

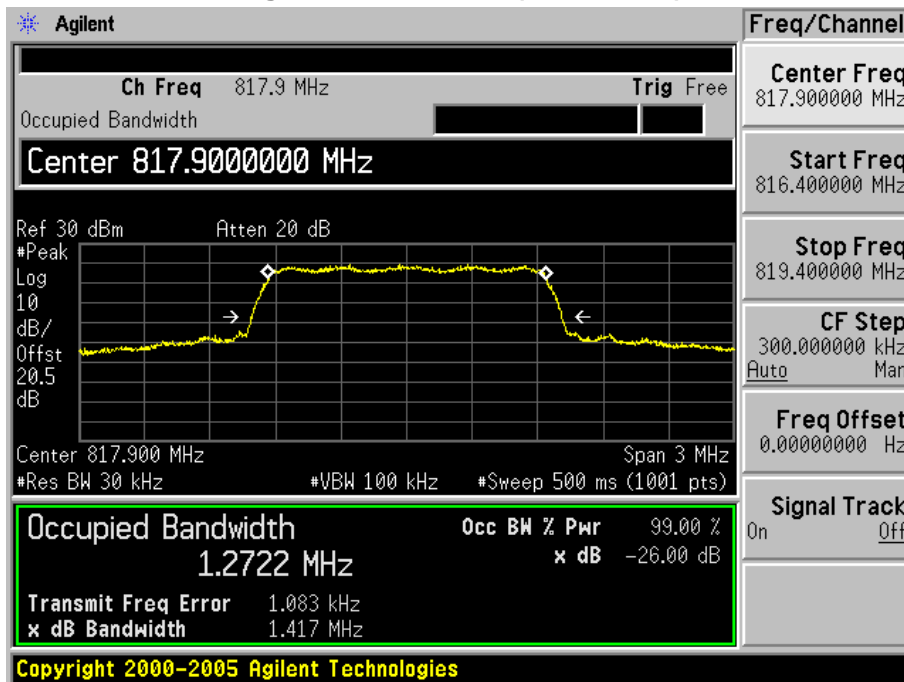

Figure Channel 580 (820.50MHz)

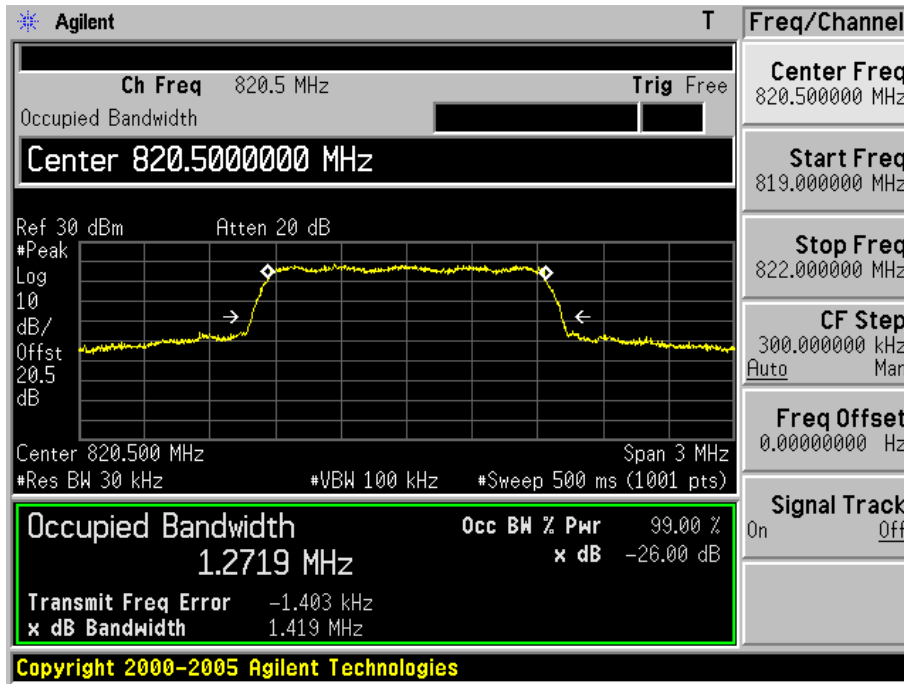
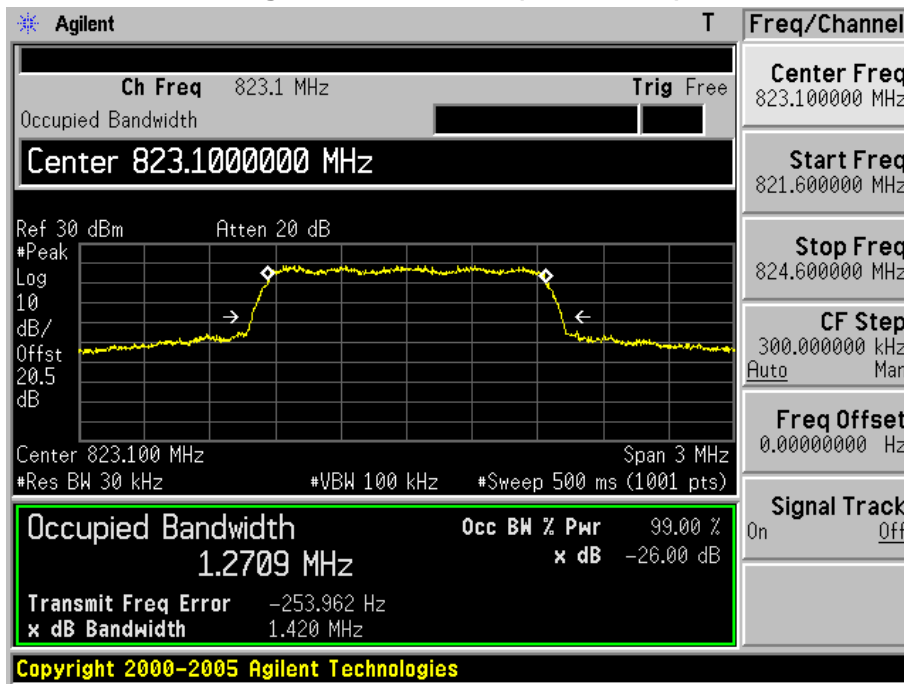

Figure Channel 684 (823.10MHz)



Product	Wireless Module		
Test Item	Occupied Bandwidth		
Test Mode	Mode 4: CDMA 2000 1XEVD0 Rel-0 BC0 Link		
Date of Test	2015/01/16	Test Site	AC-6

Channel No.	Frequency (MHz)	-26dB Occupied Bandwidth (kHz)	99% Occupied Bandwidth (kHz)
1013	824.70	1421.00	1269.80
384	836.52	1420.00	1270.10
777	848.31	1415.00	1271.40

Figure Channel 1013 (824.70MHz)

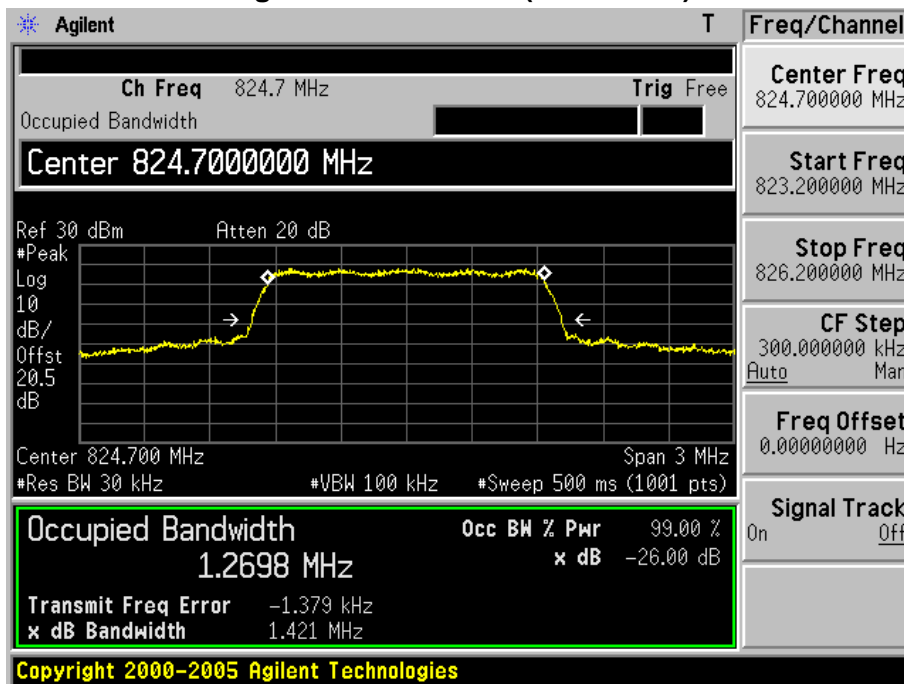

Figure Channel 384 (836.52MHz)

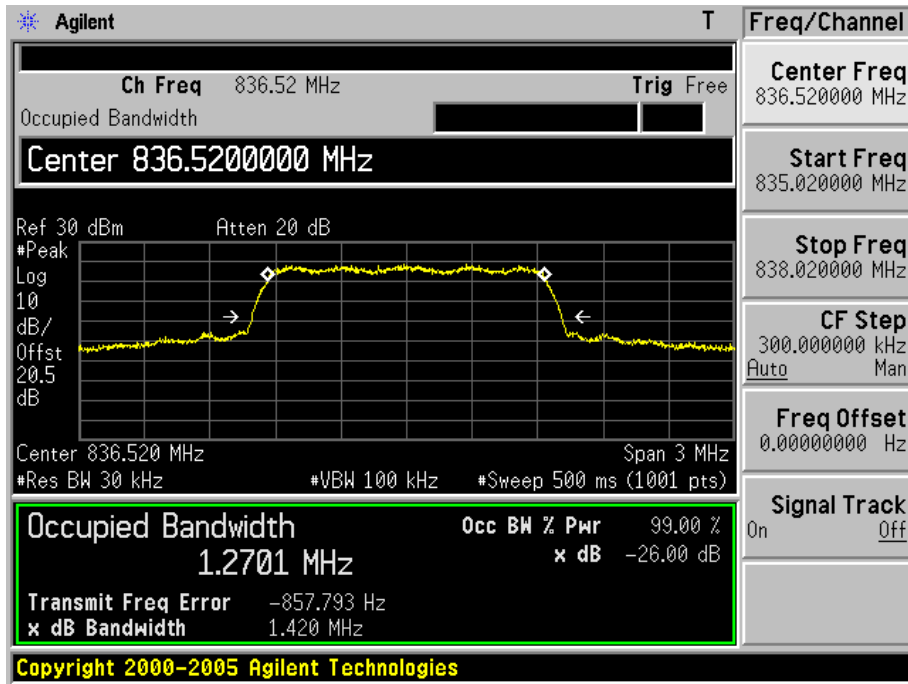
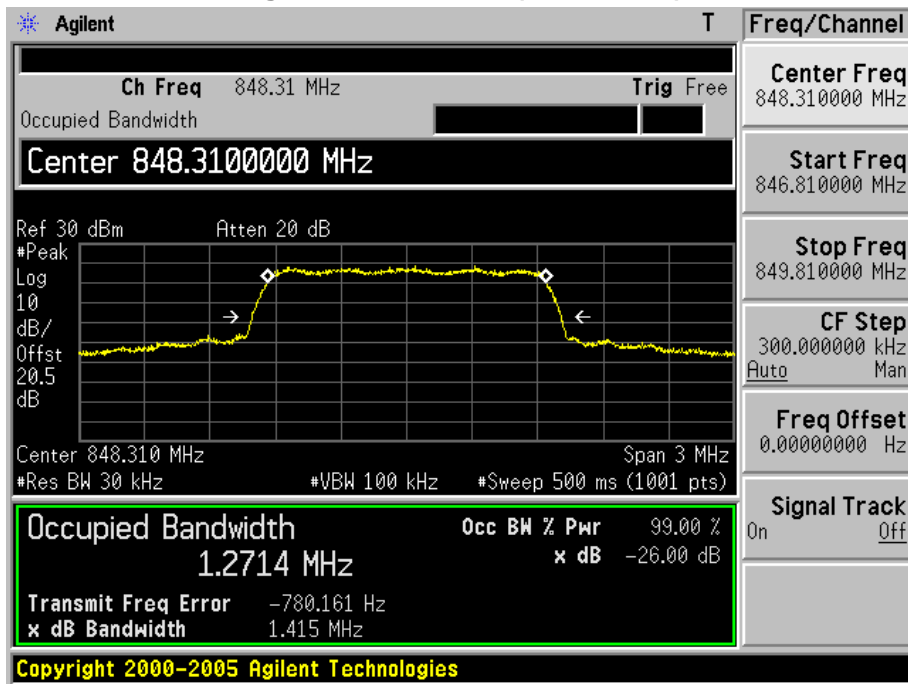

Figure Channel 777 (848.31MHz)



Product	Wireless Module		
Test Item	Occupied Bandwidth		
Test Mode	Mode 5 :CDMA 2000 1XEVD0 Rel-0 BC1 Link		
Date of Test	2015/01/16	Test Site	AC-6

Channel No.	Frequency (MHz)	-26dB Occupied Bandwidth (kHz)	99% Occupied Bandwidth (kHz)
25	1851.25	1427.00	1274.60
600	1880.00	1423.00	1272.90
1175	1908.75	1417.00	1271.20

Figure Channel 25 (1851.25MHz)

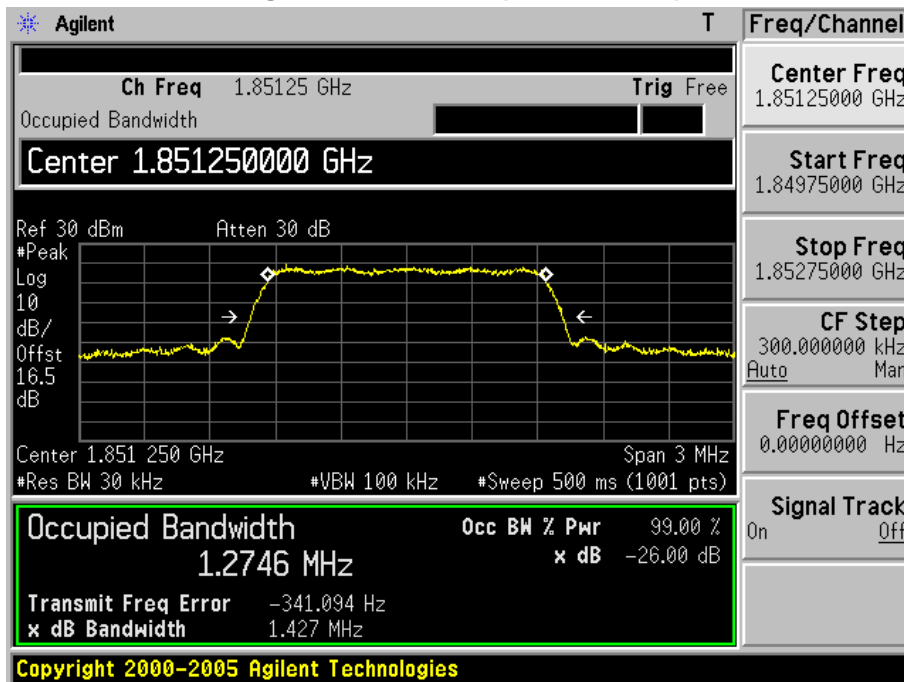

Figure Channel 600 (1880MHz)

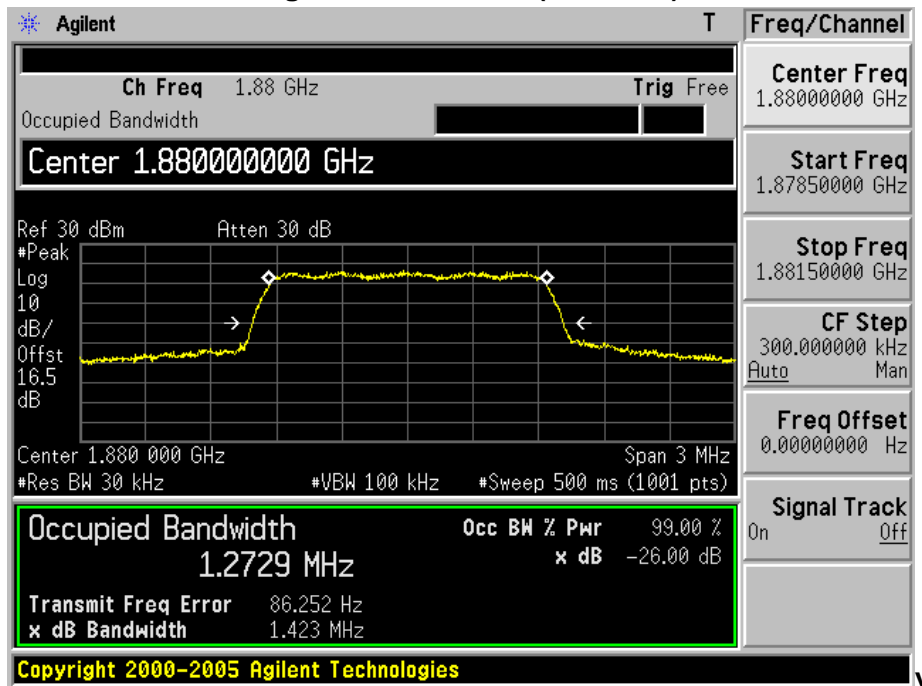
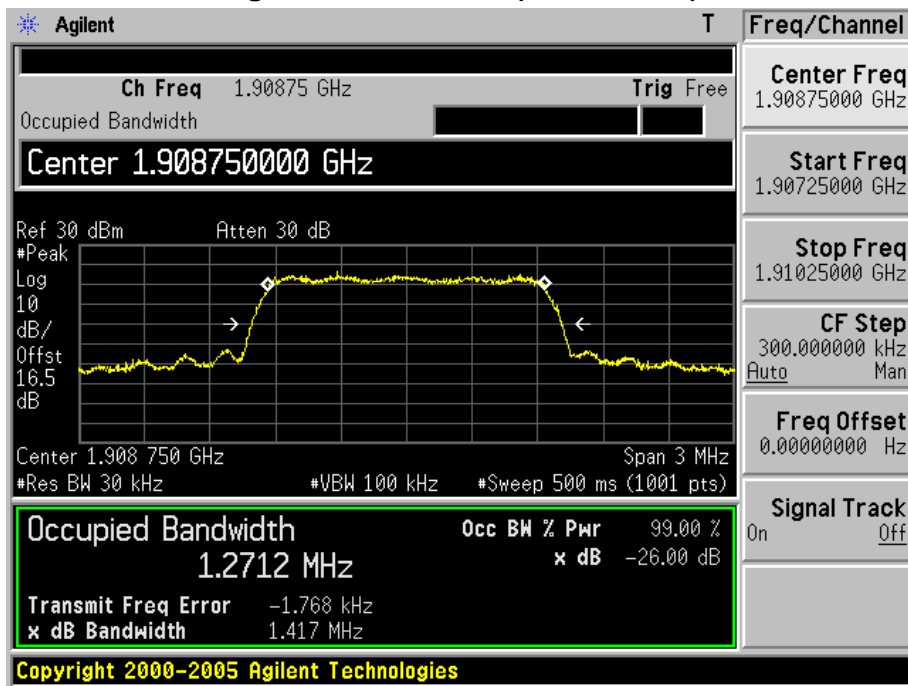

Figure Channel 1175 (1908.75MHz)



Product	Wireless Module		
Test Item	Occupied Bandwidth		
Test Mode	Mode 6 :CDMA 2000 1XEVD0 Rel-0 BC10 Link		
Date of Test	2015/02/09	Test Site	AC-6

Channel No.	Frequency (MHz)	-26dB Occupied Bandwidth (kHz)	99% Occupied Bandwidth (kHz)
476	817.90	1422.00	1273.60
580	820.50	1419.00	1271.40
684	823.10	1414.00	1270.20

Figure Channel 476 (817.90MHz)

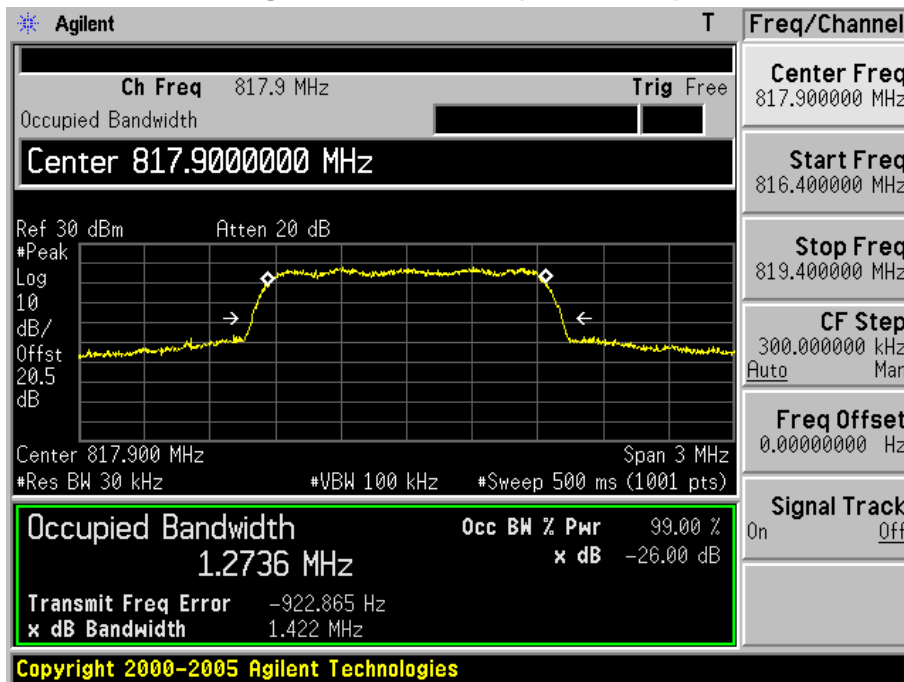

Figure Channel 580 (820.50MHz)

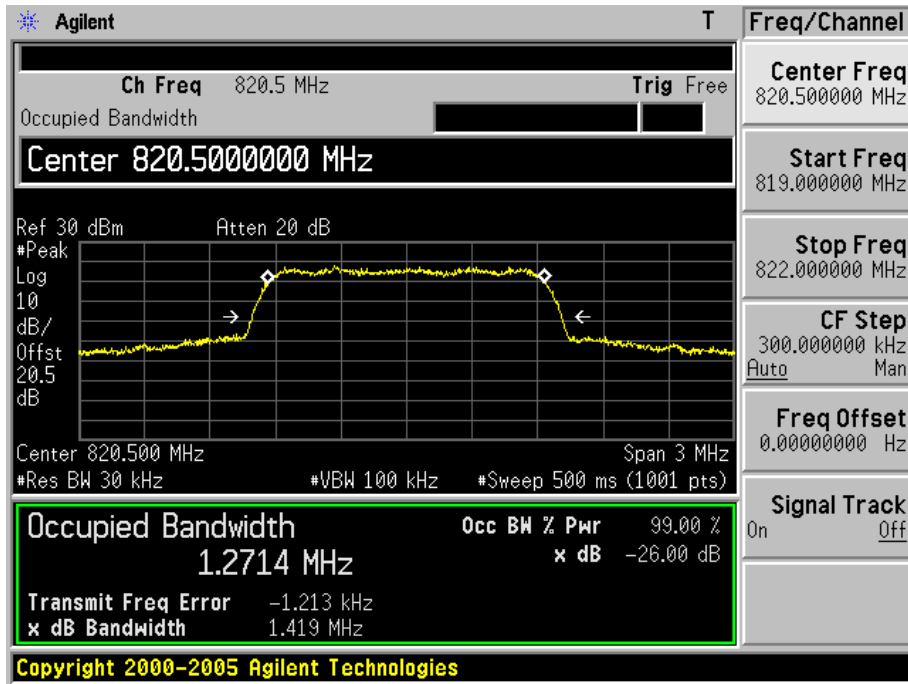
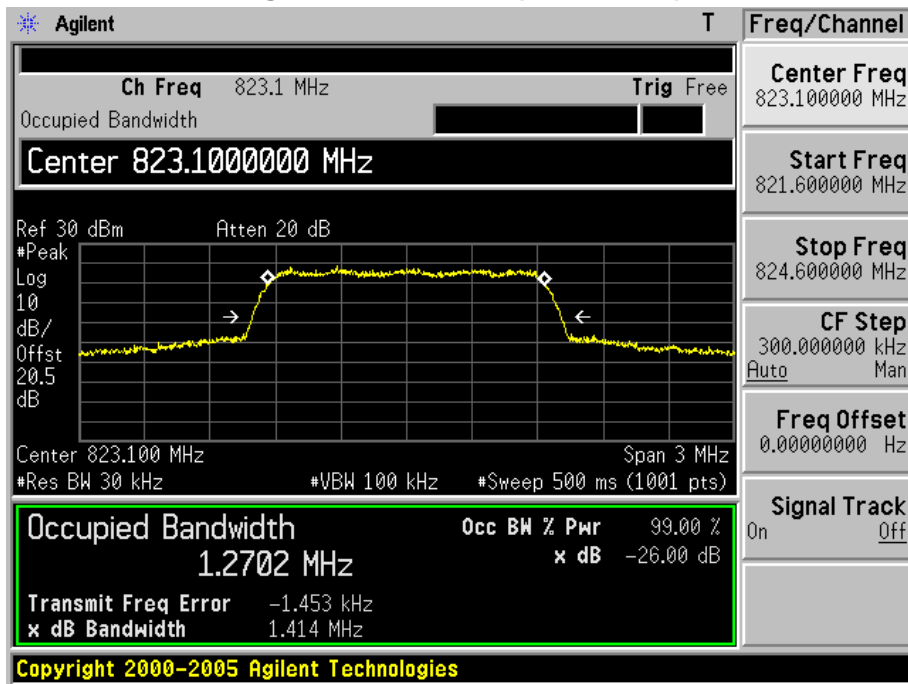

Figure Channel 684 (823.10MHz)



Product	Wireless Module		
Test Item	Occupied Bandwidth		
Test Mode	Mode 7 :CDMA 2000 1XEVD0 Rel-A BC0 Link		
Date of Test	2015/01/16	Test Site	AC-6

Channel No.	Frequency (MHz)	-26dB Occupied Bandwidth (kHz)	99% Occupied Bandwidth (kHz)
1013	824.70	1416.00	1274.20
384	836.52	1421.00	1273.80
777	848.31	1422.00	1272.00

Figure Channel 1013 (824.70MHz)

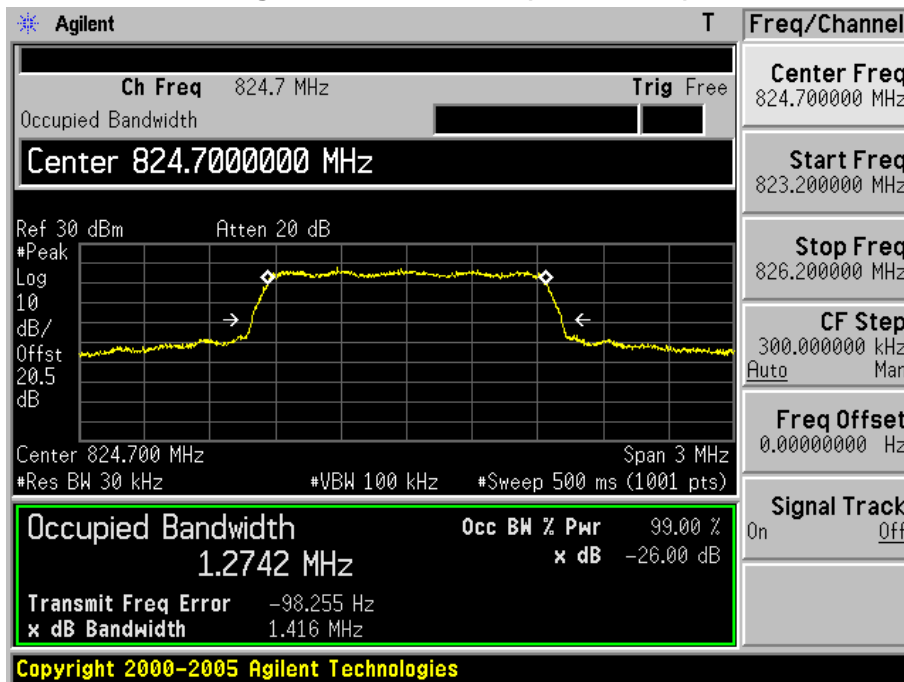

Figure Channel 384 (836.52MHz)

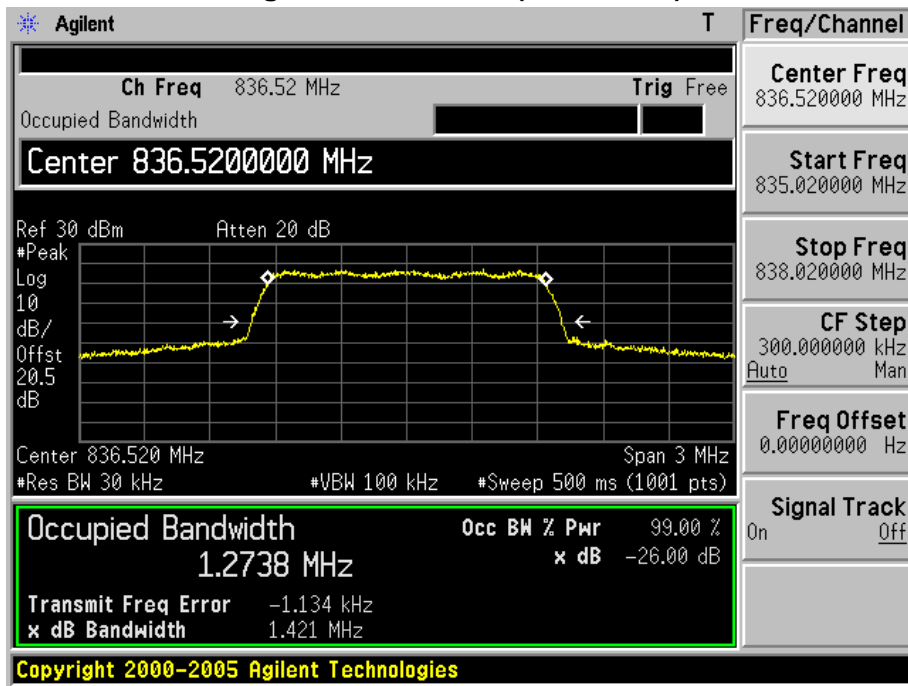
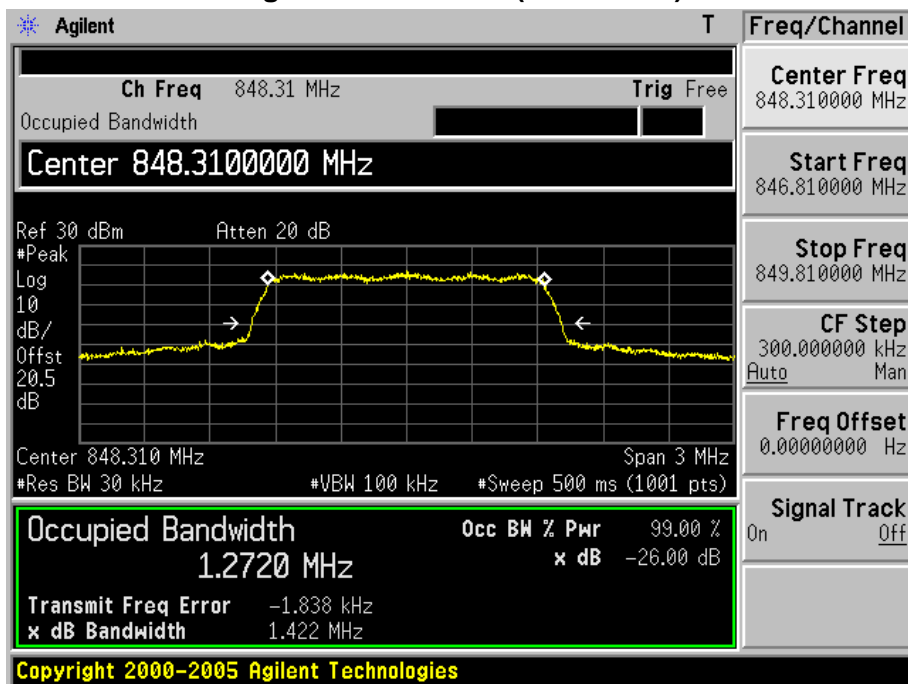

Figure Channel 777 (848.31MHz)



Product	Wireless Module		
Test Item	Occupied Bandwidth		
Test Mode	Mode 8: CDMA 2000 1XEVD0 Rel-A BC1 Link		
Date of Test	2015/01/15	Test Site	AC-6

Channel No.	Frequency (MHz)	-26dB Occupied Bandwidth (kHz)	99% Occupied Bandwidth (kHz)
25	1851.25	1428.00	1272.60
600	1880.00	1420.00	1272.70
1175	1908.75	1424.00	1274.10

Figure Channel 25 (1851.25MHz)

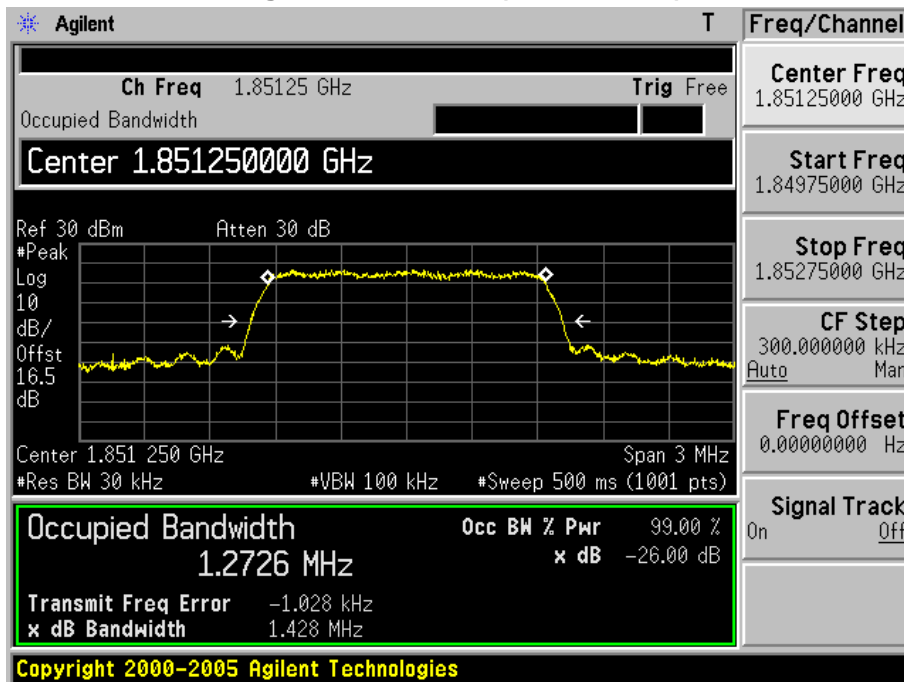

Figure Channel 600 (1880MHz)

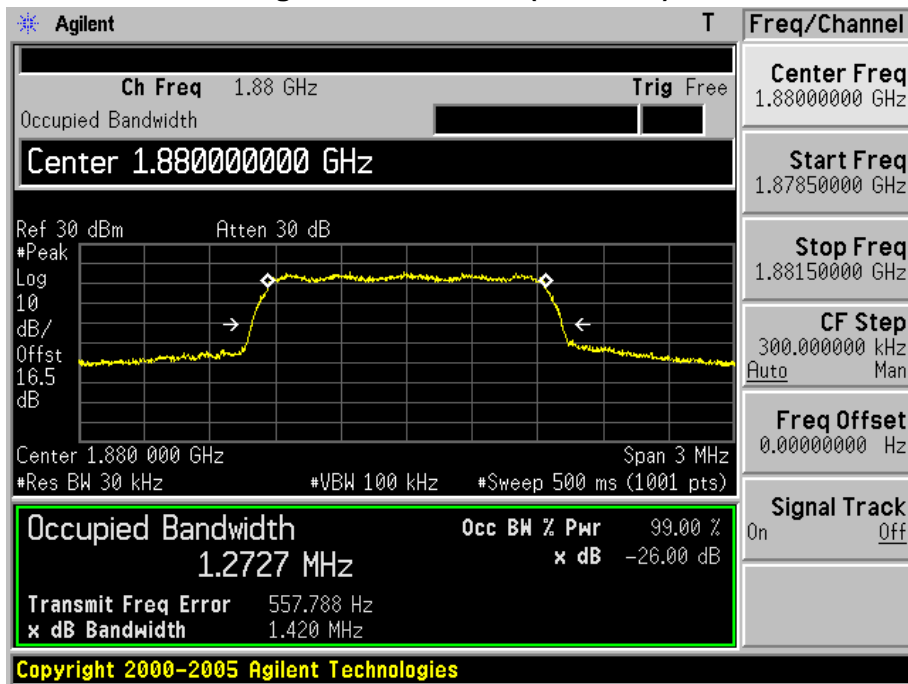
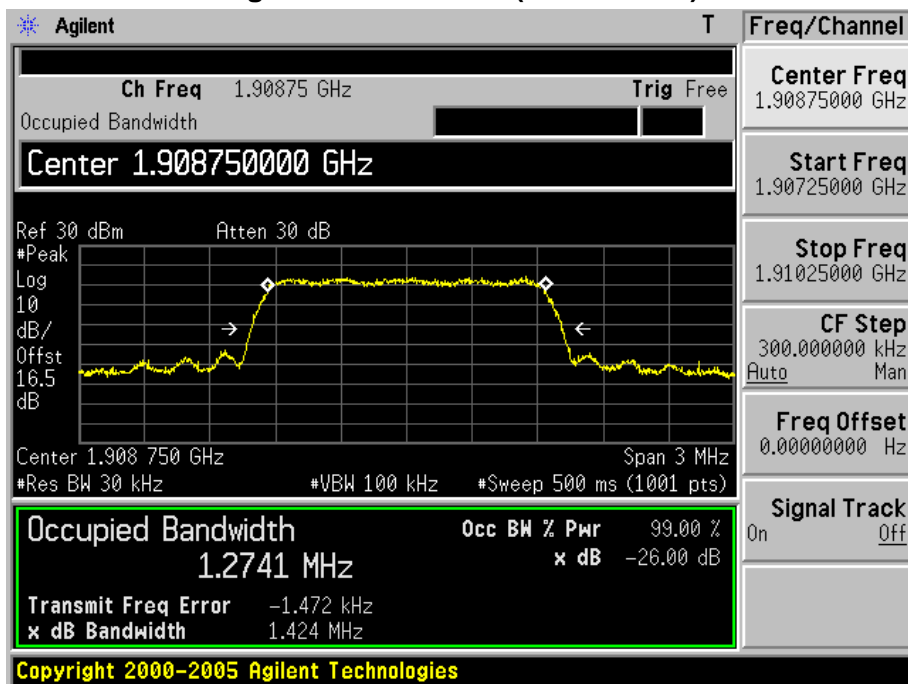

Figure Channel 1175 (1908.75MHz)



Product	Wireless Module		
Test Item	Occupied Bandwidth		
Test Mode	Mode 9: CDMA 2000 1XEVD0 Rel-A BC10 Link		
Date of Test	2015/02/09	Test Site	AC-6

Channel No.	Frequency (MHz)	-26dB Occupied Bandwidth (kHz)	99% Occupied Bandwidth (kHz)
476	817.90	1422.00	1273.60
580	820.50	1422.00	1270.90
684	823.10	1420.00	1273.90

Figure Channel 476 (817.90MHz)

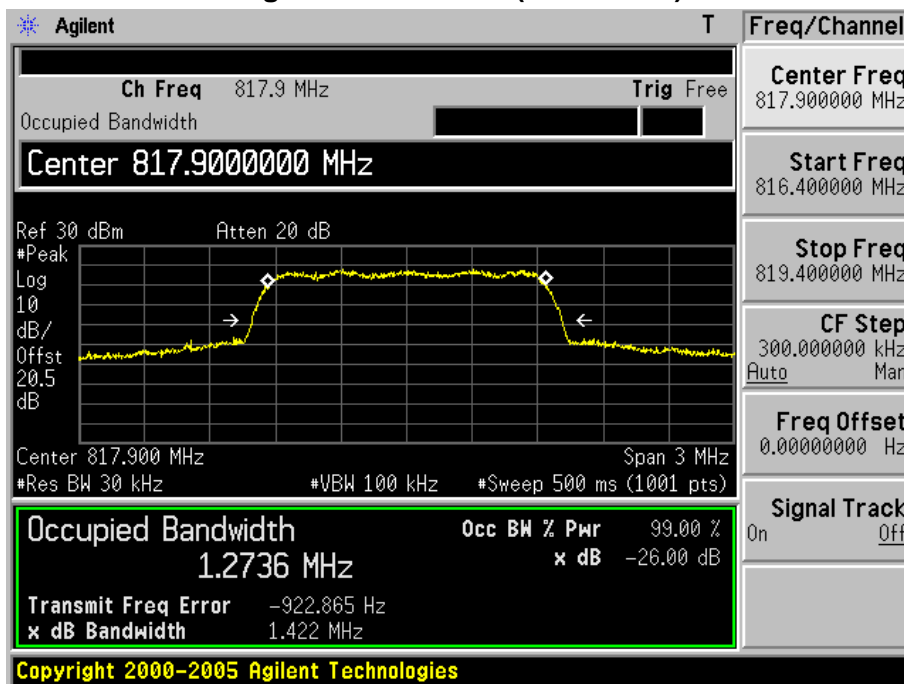

Figure Channel 580 (820.50MHz)

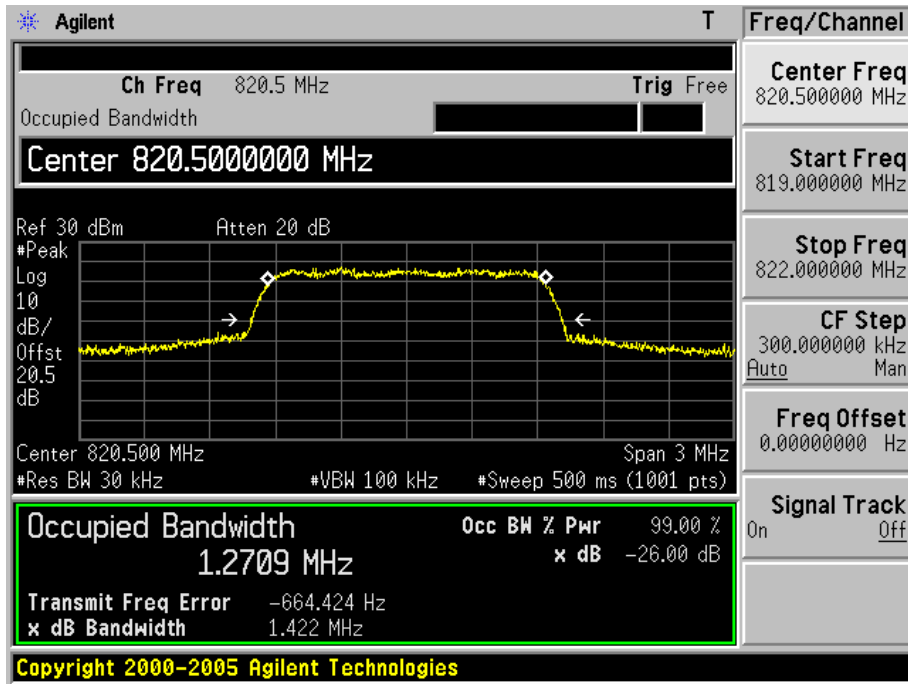
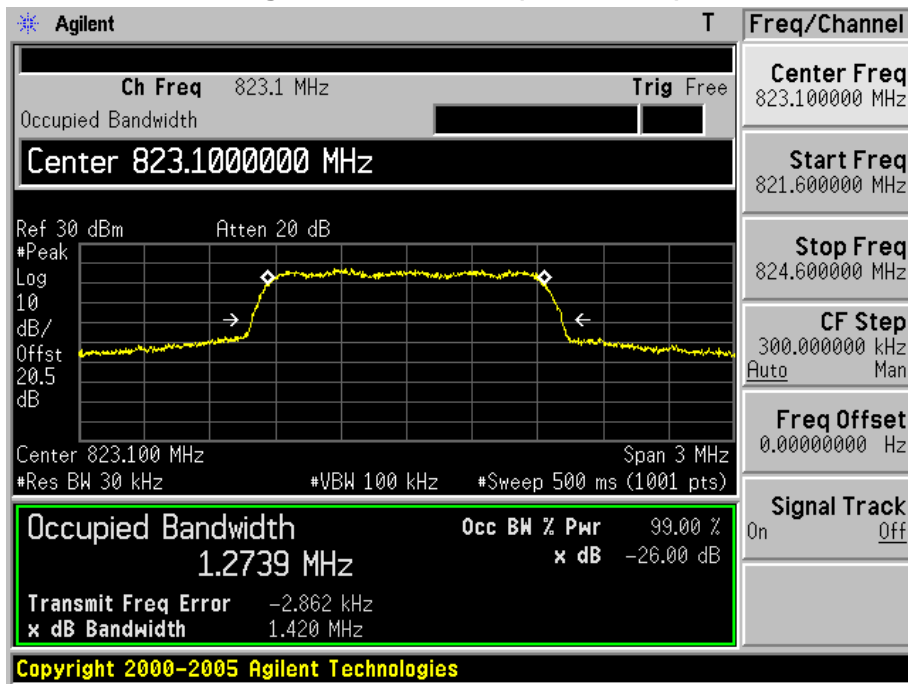

Figure Channel 684 (823.10MHz)



6. Conducted Band Edge

6.1. Test Equipment

Spurious Emission At Antenna Terminals (+/- 1MHz) / AC-6

Instrument	Manufacturer	Type No.	Serial No	Cali. Due Date
PSA Series Spectrum Analyzer	Agilent	E4440A	MY49420184	2015.03.28
Radio Communication Tester	R&S	CMU 200	117088	2015.03.28
Dual Directional Coupler	Agilent	778D	20160	2015.03.28
10dB Coaxial Coupler	Agilent	87300C	MY44300299	2015.03.28
Temperature/Humidity Meter	Zhicheng	ZC1-2	AC6-TH	2016.01.07

6.2. Test Setup

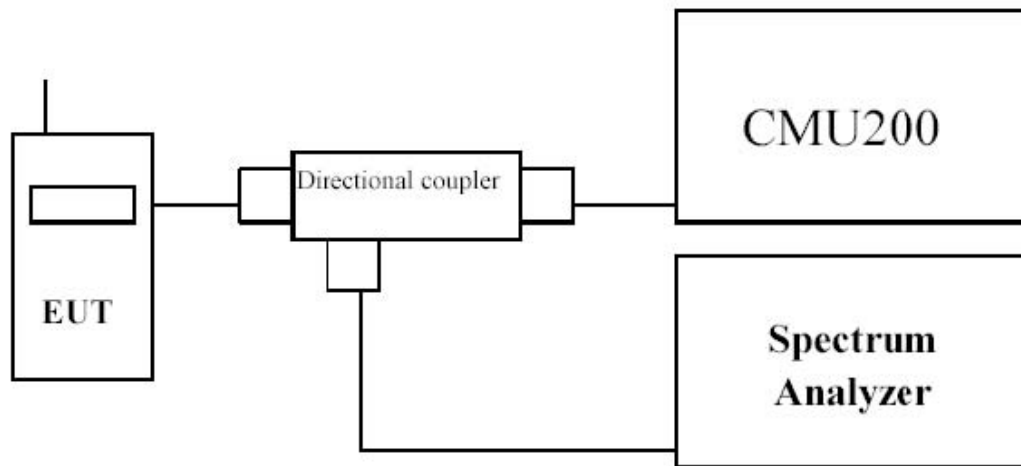

6.3. Test Procedure

1. The EUT was connected to spectrum analyzer and System Simulator via power divider.
2. The RF output of EUT was connected to the spectrum analyzer by RF cable and attenuator. The path loss was compensated to the results for each measurement.
3. The conducted spurious emission for the whole frequency range was taken.
4. In the 1MHz bands immediately outside and adjacent to the frequency block a resolution bandwidth of at least one percent of the emission bandwidth of the fundamental emission of the transmitter may be employed to measure the out of band Emissions.

6.4. Uncertainty

The measurement uncertainty is defined as ± 1.2 dB.

6.5. Test Result

Product	Wireless Module		
Test Item	Spurious Emission At Antenna Terminals (+/- 1MHz)		
Test Mode	Mode 1: CDMA 2000 1X BC0 Link		
Date of Test	2015/01/16	Test Site	AC-6

Figure Channel 1013 (824.70MHz)

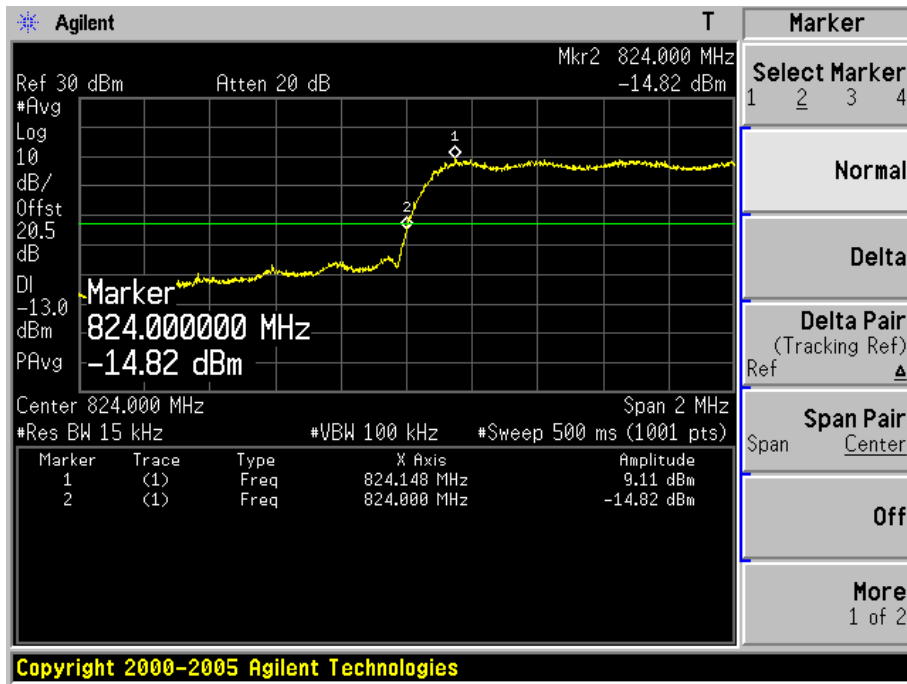
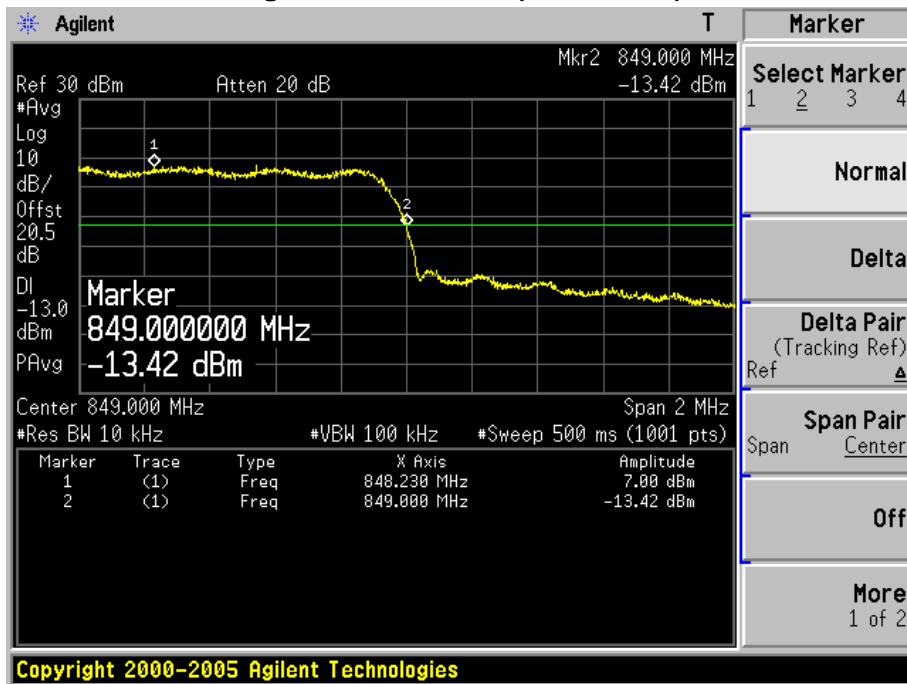

Figure Channel 777 (848.31MHz)



Product	Wireless Module		
Test Item	Spurious Emission At Antenna Terminals (+/- 1MHz)		
Test Mode	Mode 2: CDMA 2000 1X BC1 Link		
Date of Test	2015/01/16	Test Site	AC-6

Figure Channel 25 (1851.25MHz)

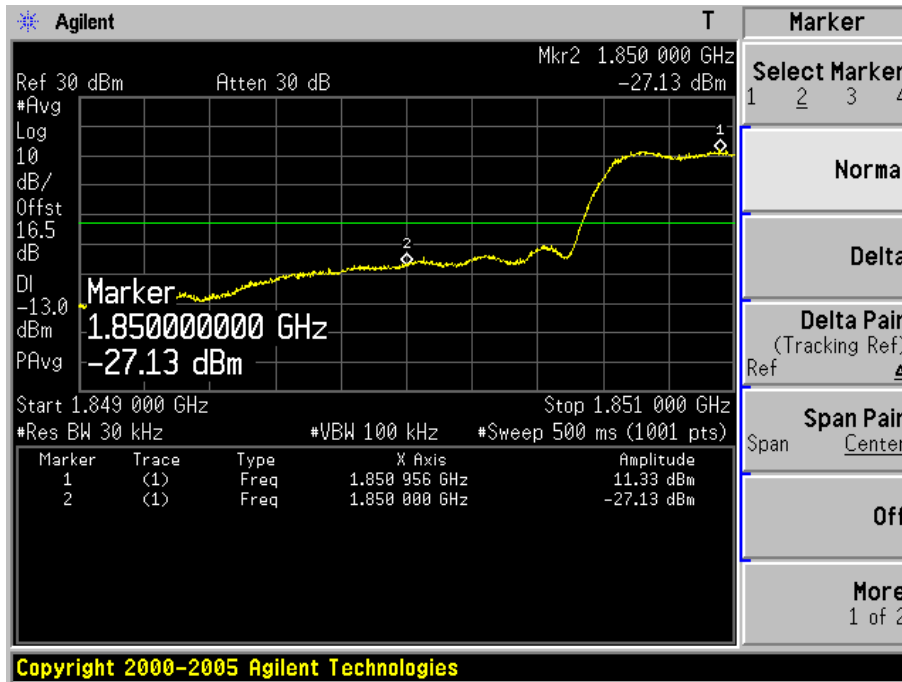
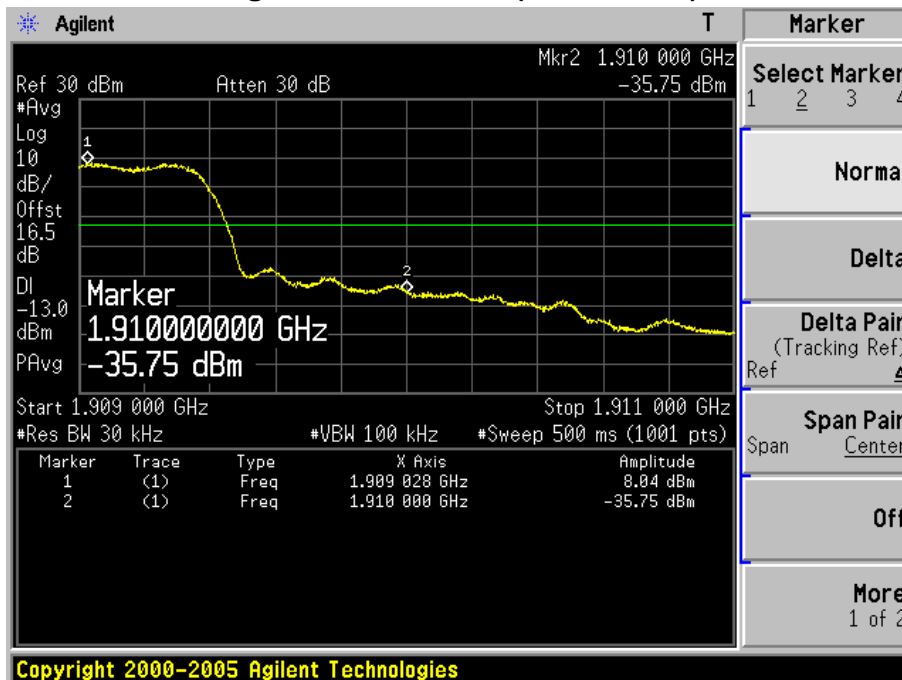

Figure Channel 1175 (1908.75MHz)



Product	Wireless Module		
Test Item	Spurious Emission At Antenna Terminals (+/- 1MHz)		
Test Mode	Mode 3: CDMA 2000 1X BC10 Link		
Date of Test	2015/02/09	Test Site	AC-6

Figure Channel 476 (817.90MHz)

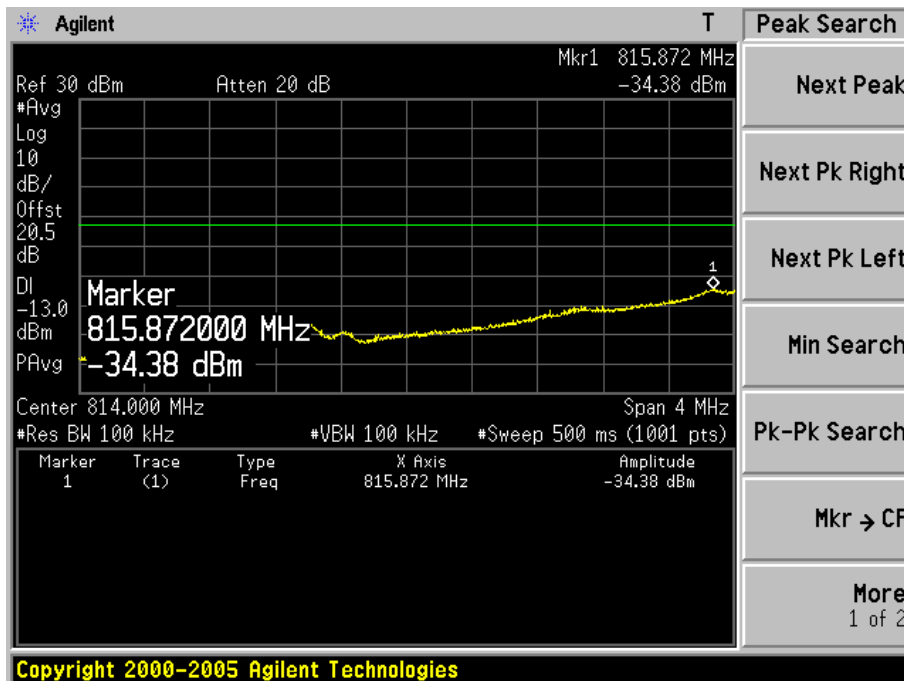
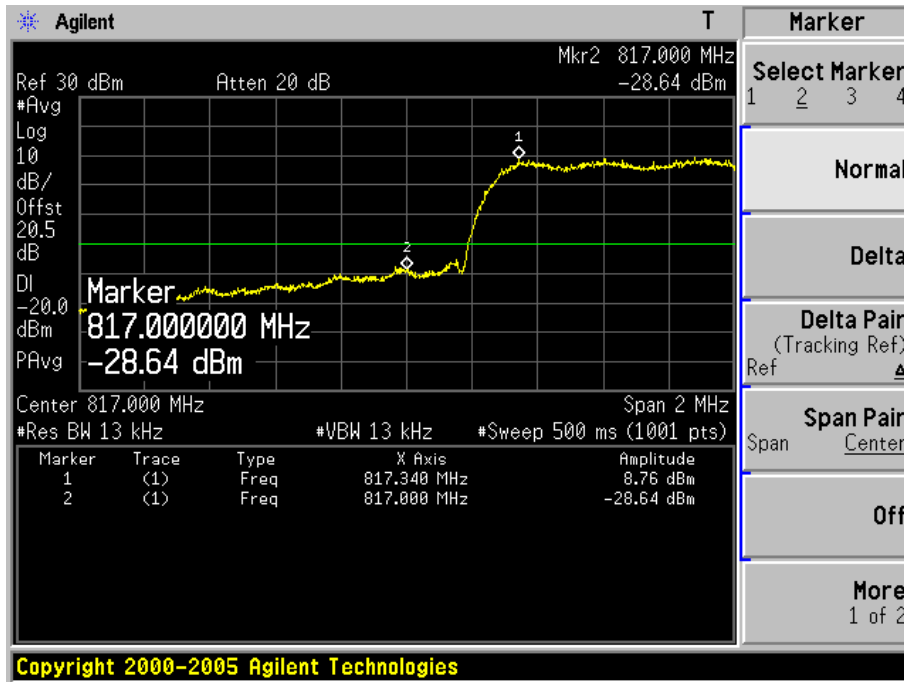
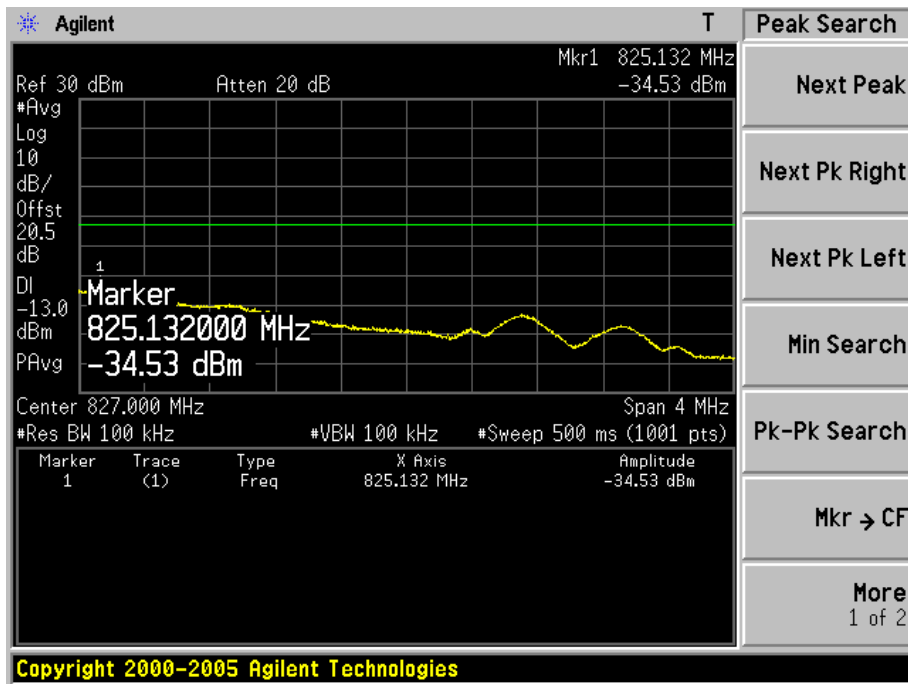
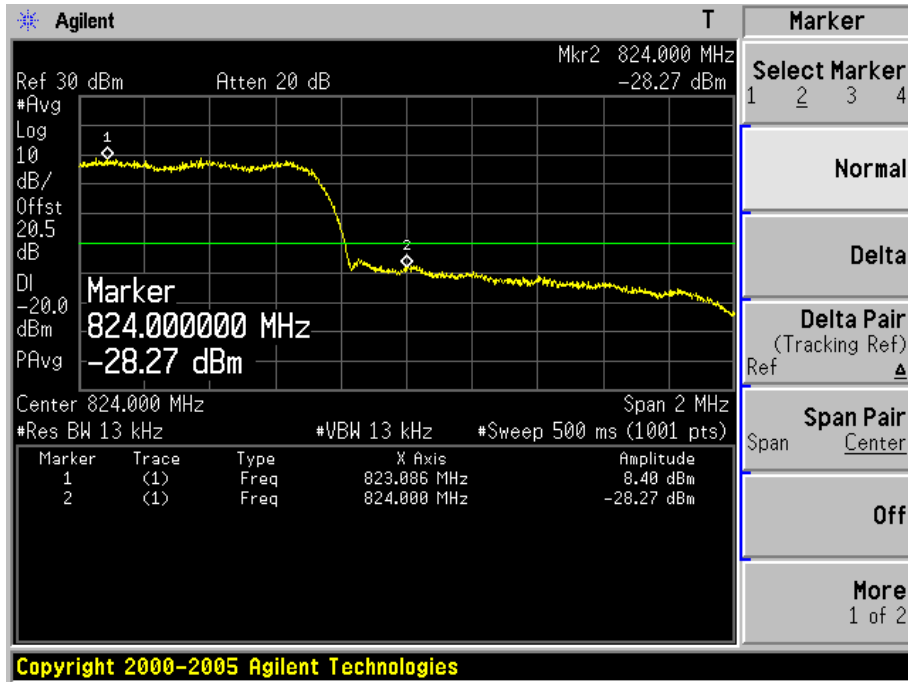

Figure Channel 684 (823.10MHz)



Product	Wireless Module		
Test Item	Spurious Emission At Antenna Terminals (+/- 1MHz)		
Test Mode	Mode 4: CDMA 2000 1XEVD0 Rel 0 BC0 Link		
Date of Test	2015/01/16	Test Site	AC-6

Figure Channel 1013 (824.70MHz)

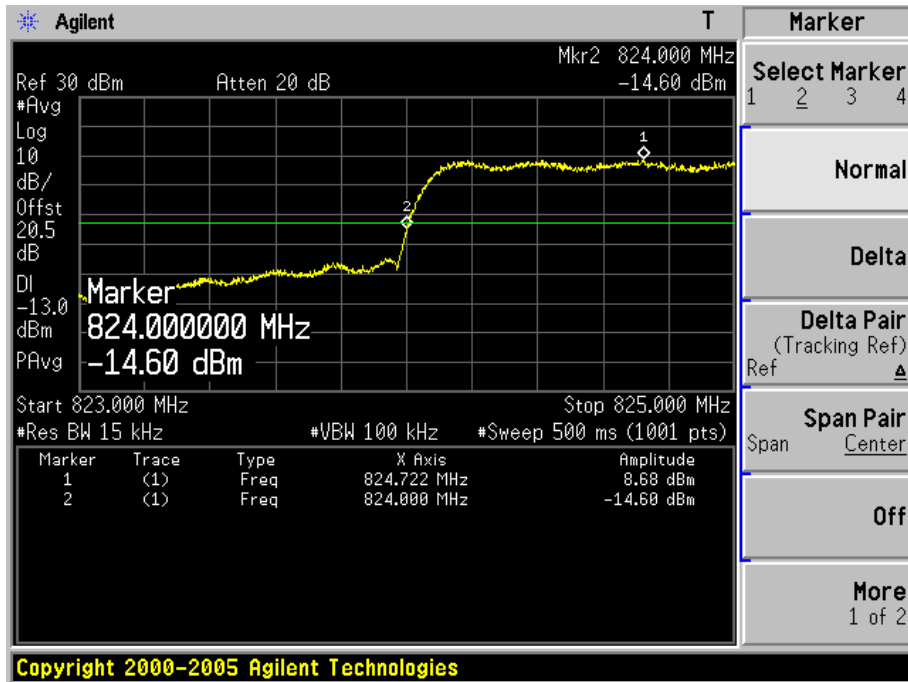
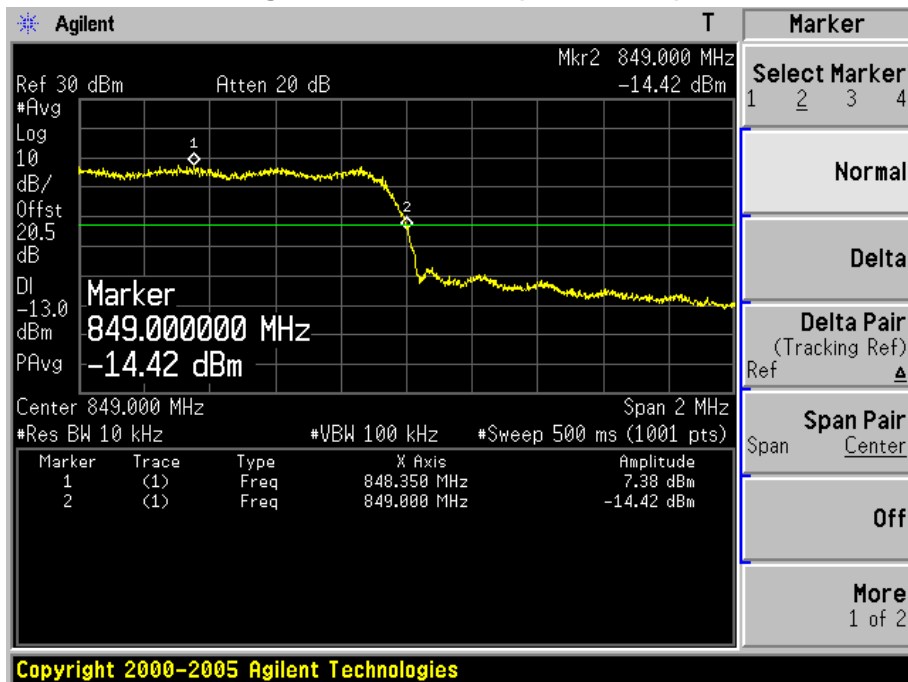

Figure Channel 777 (848.31MHz)



Product	Wireless Module		
Test Item	Spurious Emission At Antenna Terminals (+/- 1MHz)		
Test Mode	Mode 5: CDMA 2000 1XEVD0 Rel 0 BC1 Link		
Date of Test	2015/01/16	Test Site	AC-6

Figure Channel 25 (1851.25MHz)

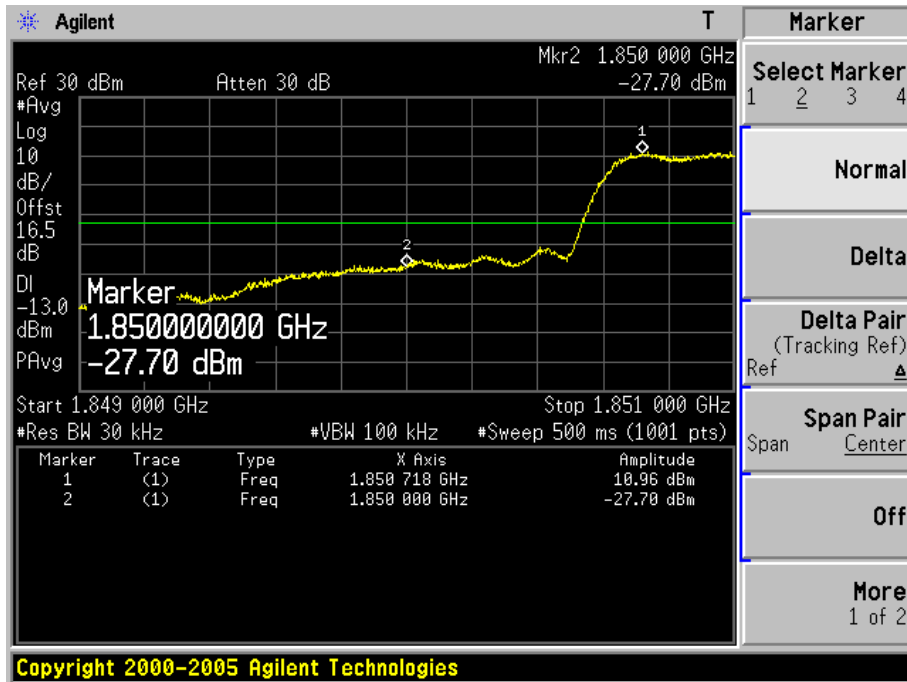
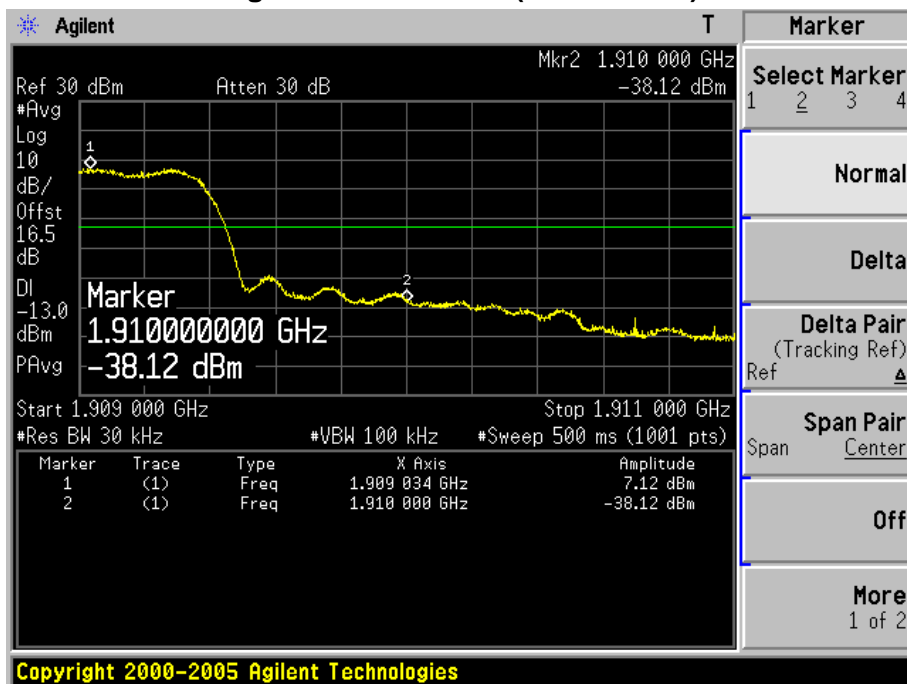

Figure Channel 1175 (1908.75MHz)



Product	Wireless Module		
Test Item	Spurious Emission At Antenna Terminals (+/- 1MHz)		
Test Mode	Mode 6: CDMA 2000 1XEVD0 Rel 0 BC10 Link		
Date of Test	2015/02/09	Test Site	AC-6

Figure Channel 476 (817.90MHz)

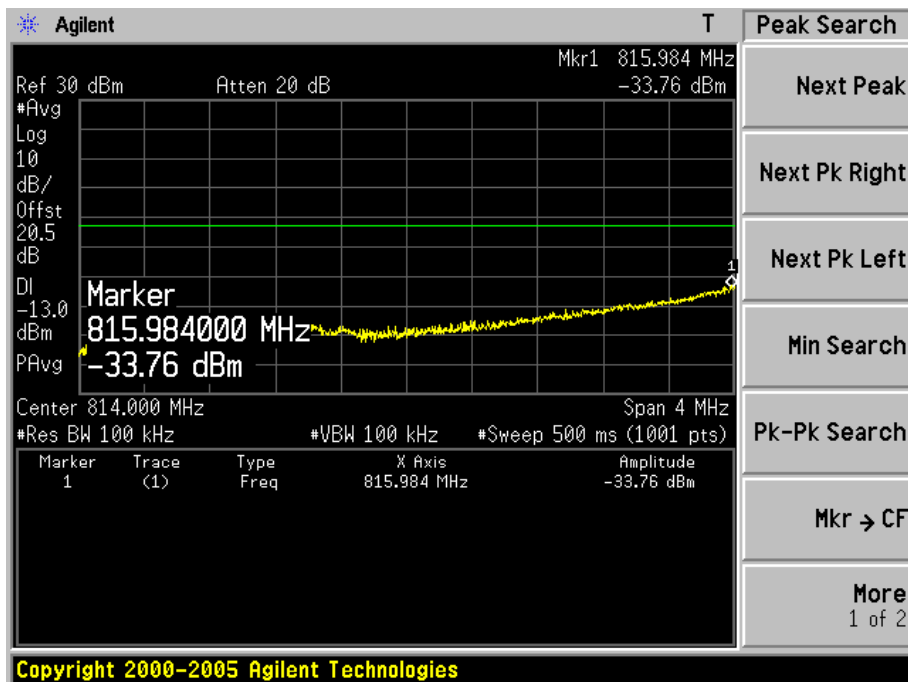
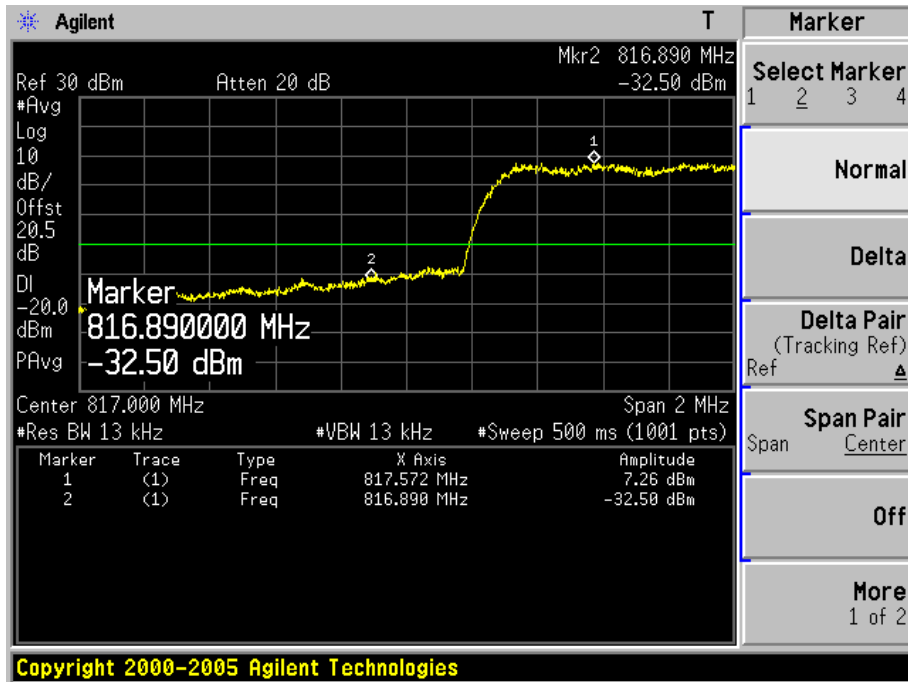
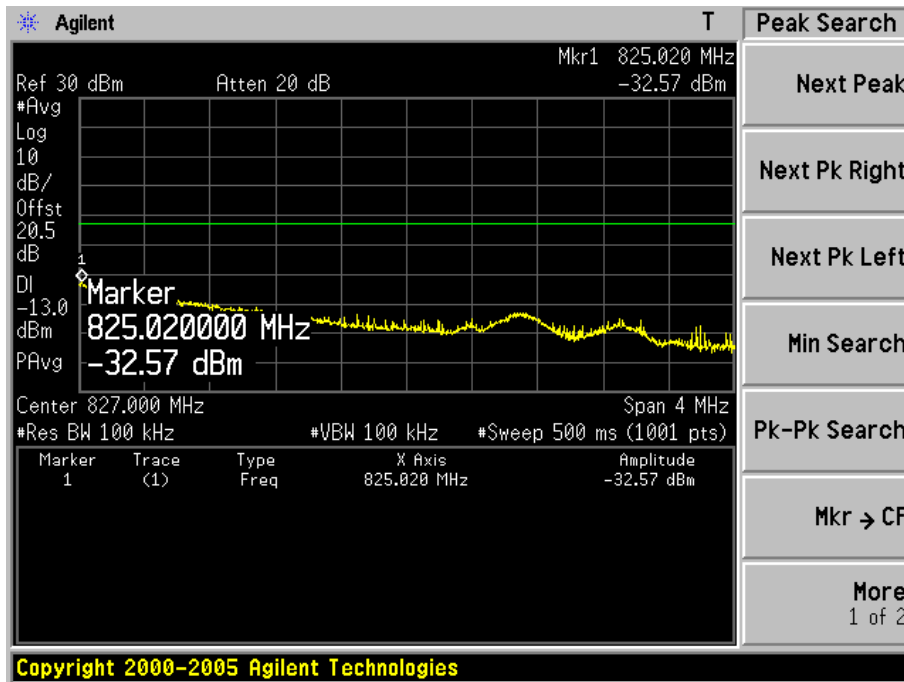
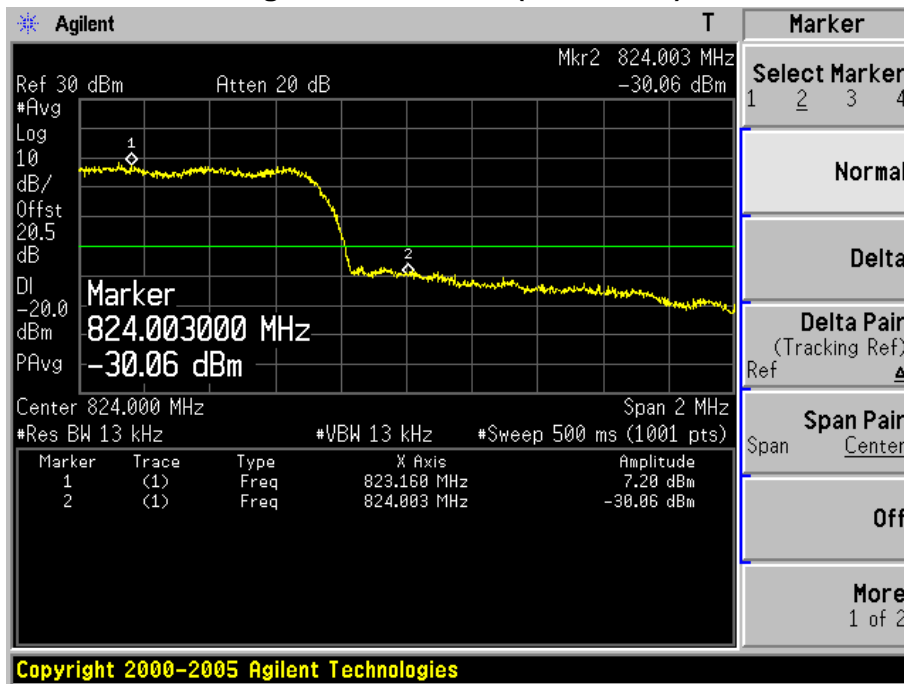

Figure Channel 684 (823.10MHz)



Product	Wireless Module		
Test Item	Spurious Emission At Antenna Terminals (+/- 1MHz)		
Test Mode	Mode 7: CDMA 2000 1XEVD0 Rel A BC0 Link		
Date of Test	2015/02/09	Test Site	AC-6

Figure Channel 1013 (824.70MHz)

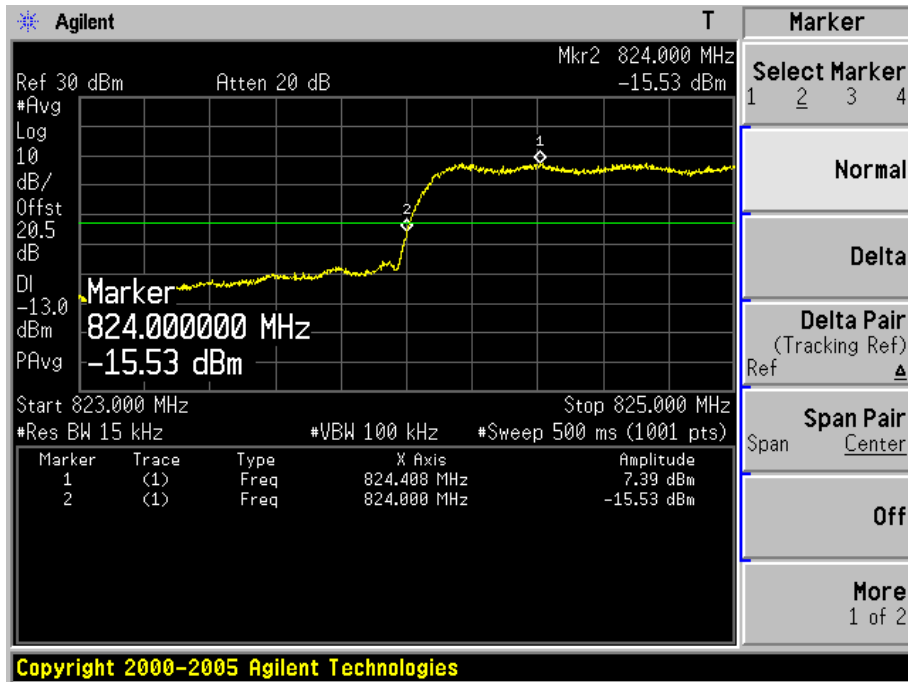
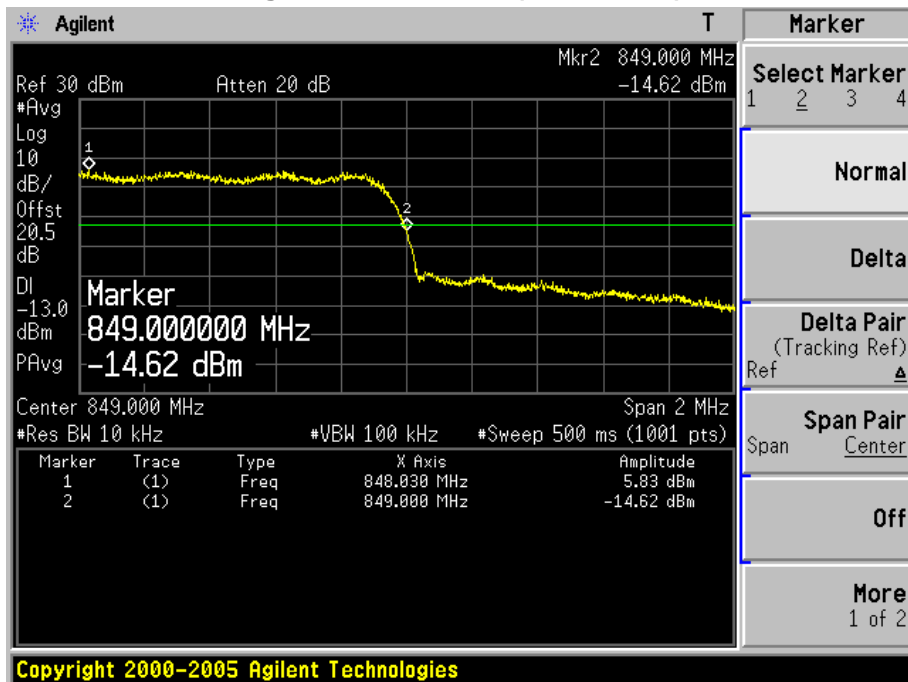

Figure Channel 777 (848.31MHz)



Product	Wireless Module		
Test Item	Spurious Emission At Antenna Terminals (+/- 1MHz)		
Test Mode	Mode 8: CDMA 2000 1XEVD0 Rel A BC1 Link		
Date of Test	2015/01/16	Test Site	AC-6

Figure Channel 25 (1851.25MHz)

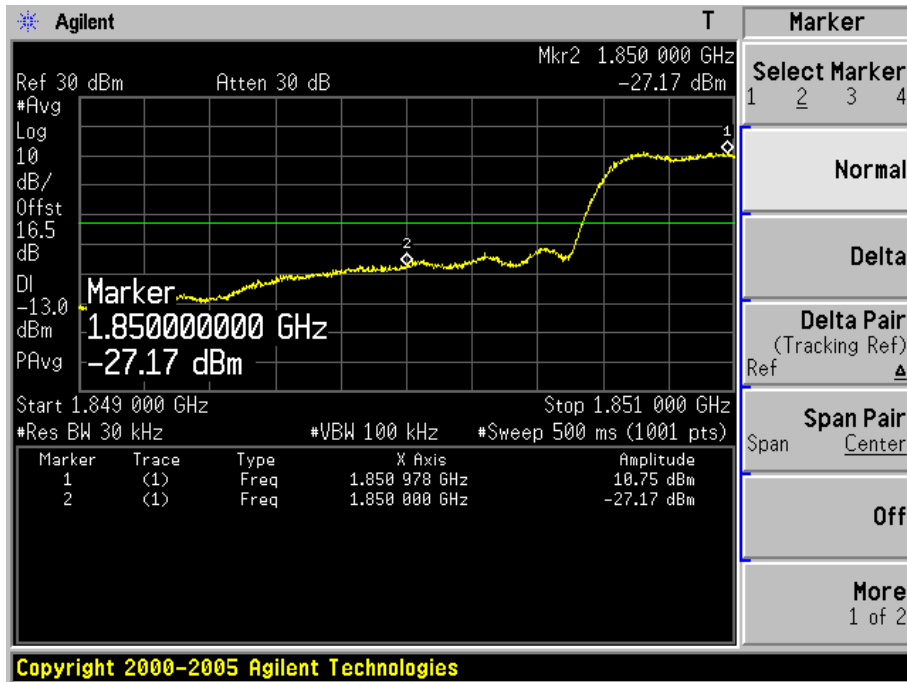
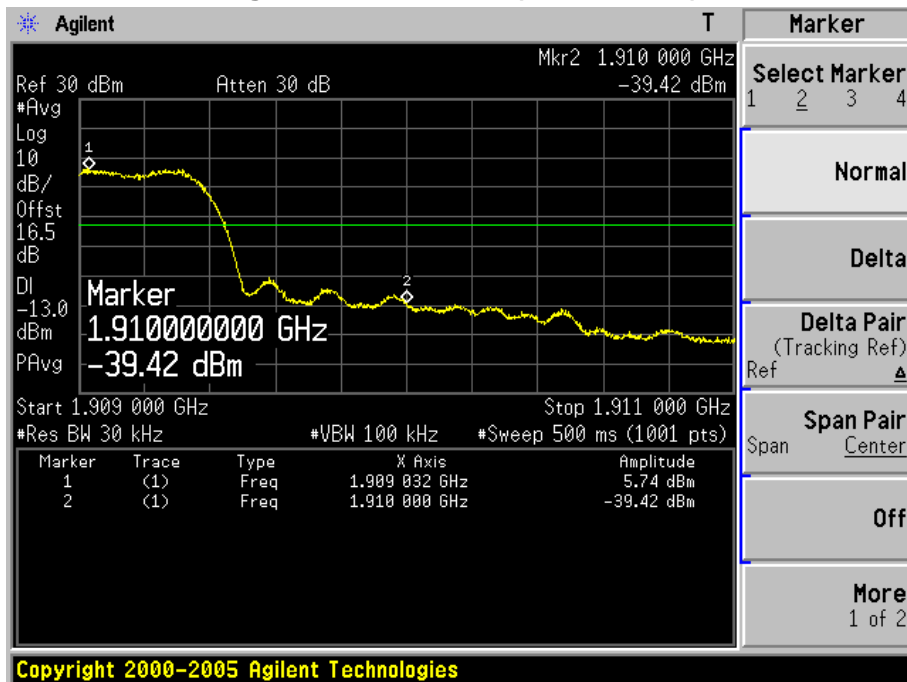

Figure Channel 1175 (1908.75MHz)



Product	Wireless Module		
Test Item	Spurious Emission At Antenna Terminals (+/- 1MHz)		
Test Mode	Mode 9: CDMA 2000 1XEVD0 Rel A BC10 Link		
Date of Test	2015/02/09	Test Site	AC-6

Figure Channel 476 (817.90MHz)

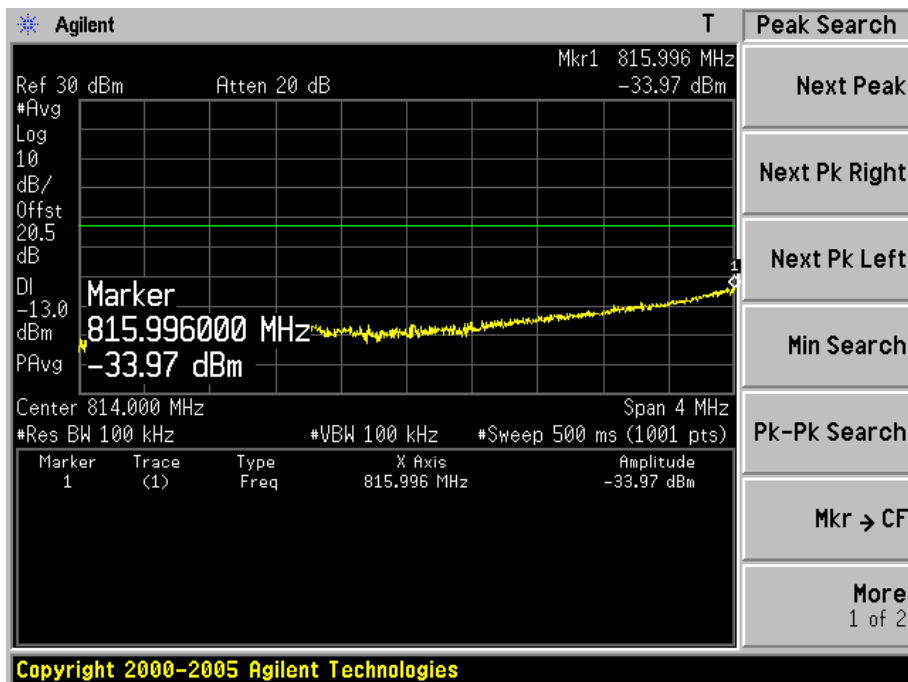
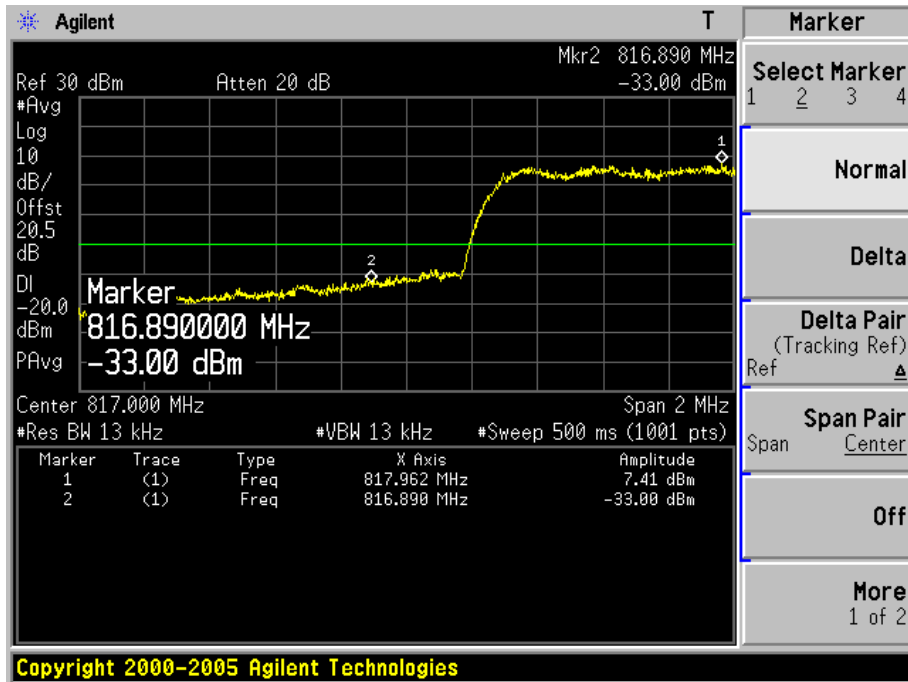
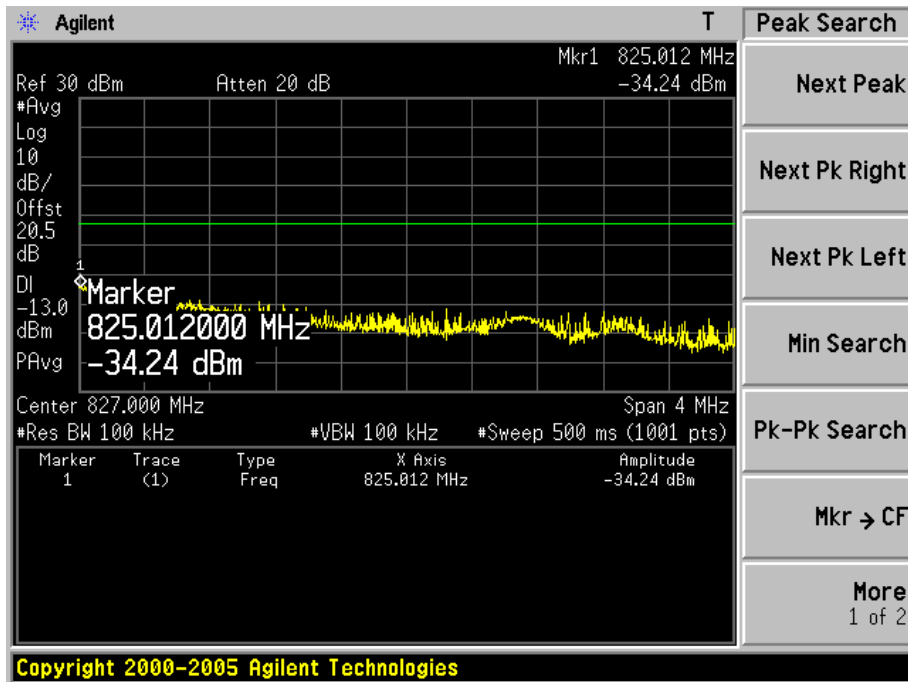
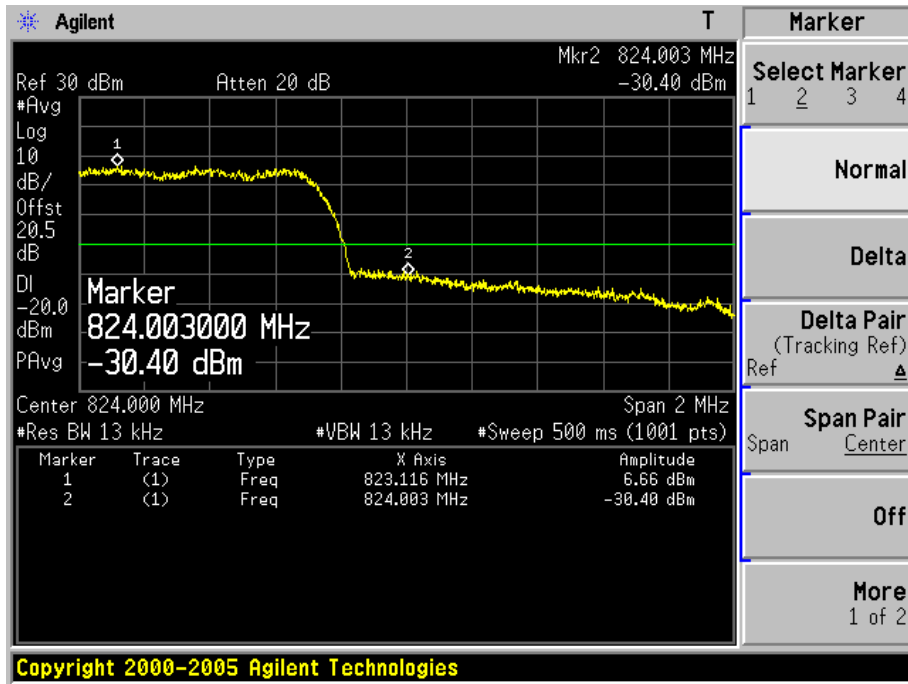

Figure Channel 684 (823.10MHz)



7. Spurious Emission

7.1. Test Equipment

Conducted Emission / AC-6

Instrument	Manufacturer	Type No.	Serial No	Cali. Due Date
PSA Series Spectrum Analyzer	Agilent	E4440A	MY49420184	2015.03.28
Radio Communication Tester	R&S	CMU 200	117088	2015.03.28
Dual Directional Coupler	Agilent	778D	20160	2015.03.28
10dB Coaxial Coupler	Agilent	87300C	MY44300299	2015.03.28
Temperature/Humidity Meter	Zhicheng	ZC1-2	AC6-TH	2016.01.07

Radiated Spurious Emission / AC-5

Instrument	Manufacturer	Type No.	Serial No	Cali. Due Date
EMI Receiver	Agilent	N9038A	MY51210196	2016.01.07
Radio Communication Tester	R&S	CMU 200	117088	2015.03.28
PSG Analog Signal Generator	Agilent	E8257D	MY44321116	2015.03.28
Preamplifier	Quietek	AP-025C	CHM-0503006	2015.04.11
Preamplifier	Miteq	NSP1800-25	1364185	2015.05.03
DRG Horn	ETS-Lindgren	3117	00123988	2016.01.07
Broad-Band Horn Antenna	Schwarzbeck	BBHA9120D	737	2015.03.01
Coaxial Cable	Huber+Suhner	SUCOFLEX 106	AC5-C1	2015.03.01
Coaxial Cable	Huber+Suhner	SUCOFLEX 106	AC5-C2	2015.03.01
Coaxial Cable	Huber+Suhner	SUCOFLEX 102	AC5-C3	2015.08.07
EMI Receiver	Agilent	N9038A	MY51210196	2016.01.07
Temperature/Humidity Meter	Zhichen	ZC1-2	AC5-TH	2015.03.30

7.2. Test Setup

Conducted Spurious Emission Measurement:

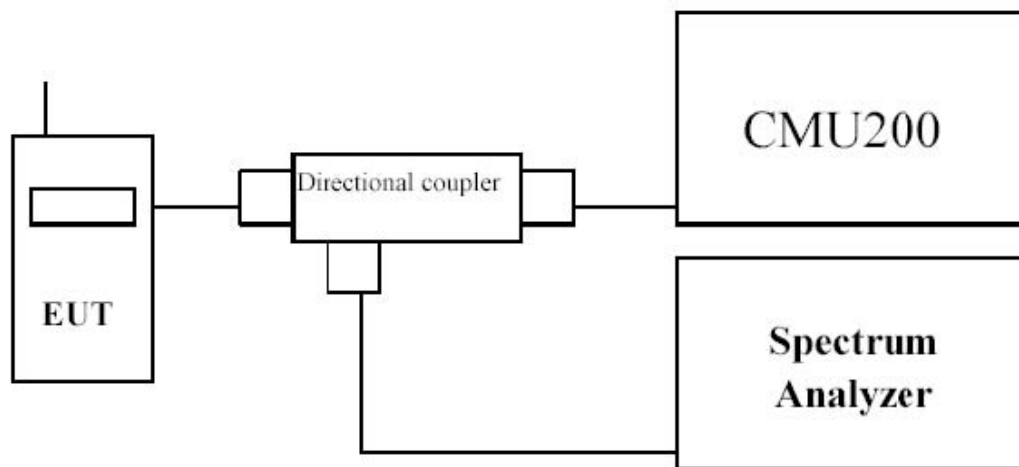

Radiated Spurious Measurement: below 1GHz

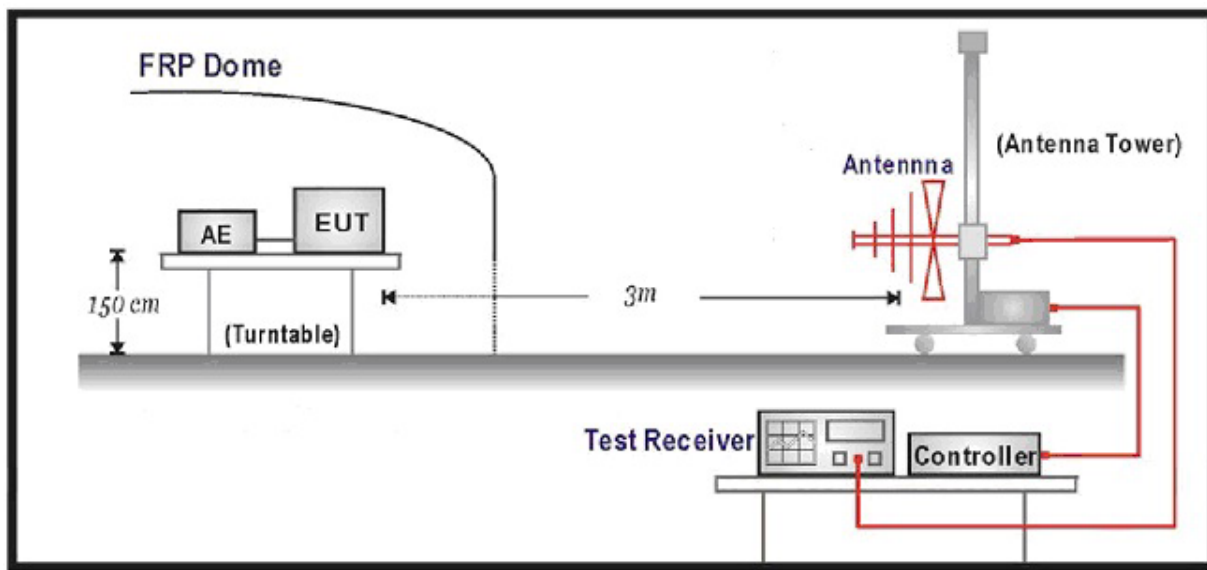

Radiated Spurious Measurement: above 1GHz

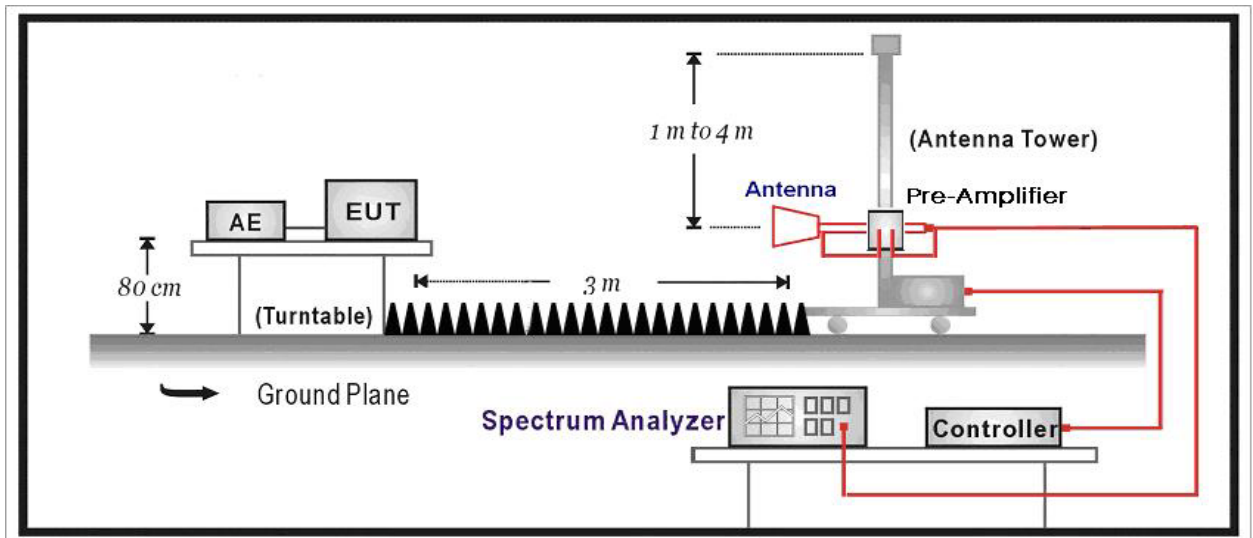

7.3. Test Procedure

Conducted Spurious Measurement:

- a) Place the EUT on a bench and set it in transmitting mode.
- b) Connect a low loss RF cable from the antenna port to a spectrum analyzer and CMU200 by a Directional Couple.
- c) EUT Communicate with CMU200, then select a channel for testing.
- d) Add a correction factor to the display of spectrum, and then test.
- e) The resolution bandwidth of the spectrum analyzer was set at 1 MHz, sufficient scans were taken to show the out of band Emission if any up to 10th harmonic.

Radiated Spurious Measurement:

- f) The EUT was placed on a rotatable wooden table with 1.5 meter above ground.
- g) The EUT was set 3 meters from the receiving antenna, which was mounted on the antenna tower.
- h) The table was rotated 360 degrees to determine the position of the highest spurious emission.
- i) The height of the receiving antenna is varied between one meter and four meters to search the maximum spurious emission for both horizontal and vertical polarizations.
- j) Make the measurement with the spectrum analyzer's RBW = 1MHz, VBW = 1MHz, Sweep 500ms, Taking the record of maximum spurious emission.
- k) A horn antenna was substituted in place of the EUT and was driven by a signal generator.
- l) Tune the output power of signal generator to the same emission level with EUT maximum spurious emission.
- m) Taking the record of output power at antenna port
- n) Repeat step 7 to step 8 for another polarization.I receiver.
- o) $EIRP = SG - \text{Cable loss} + \text{Antenna Gain}$

7.4. Uncertainty

The measurement uncertainty is defined as 3.2 dB for Radiated Power Measurement.

7.5. Test Result

Product	Wireless Module		
Test Item	Conducted Spurious Emission		
Test Mode	Mode 1: CDMA 2000 1X BC0 Link Link		
Date of Test	2015/01/16	Test Site	TR-8

Low Channel 1013(824.7MHz)

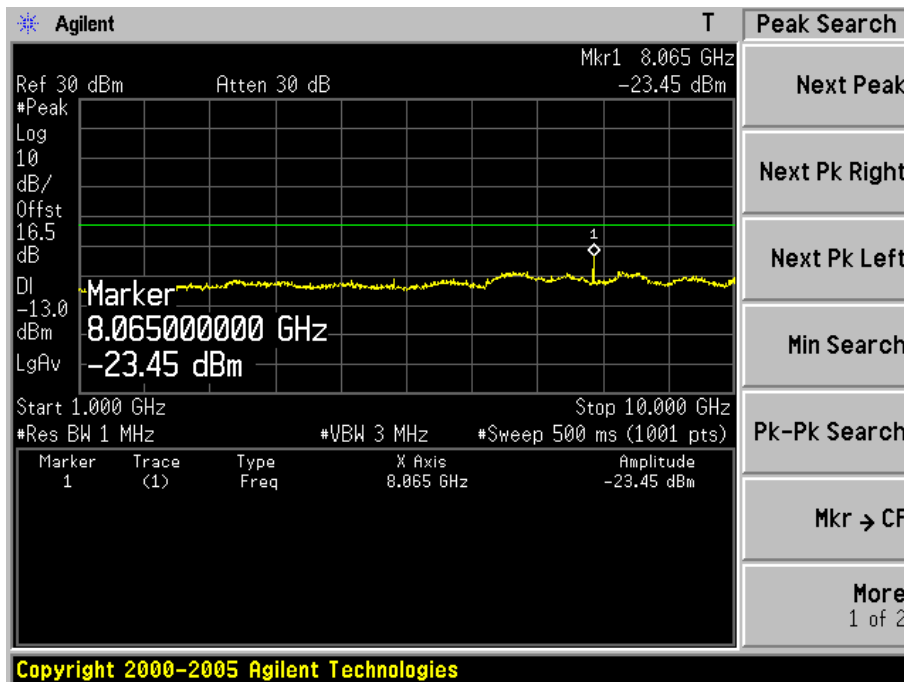
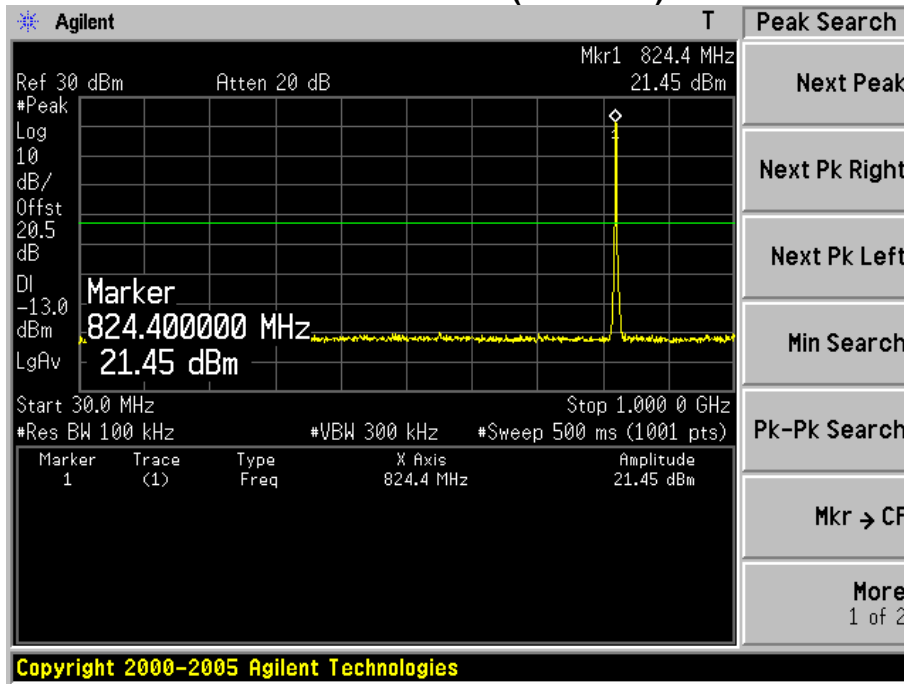

Mid Channel 384(836.52MHz)

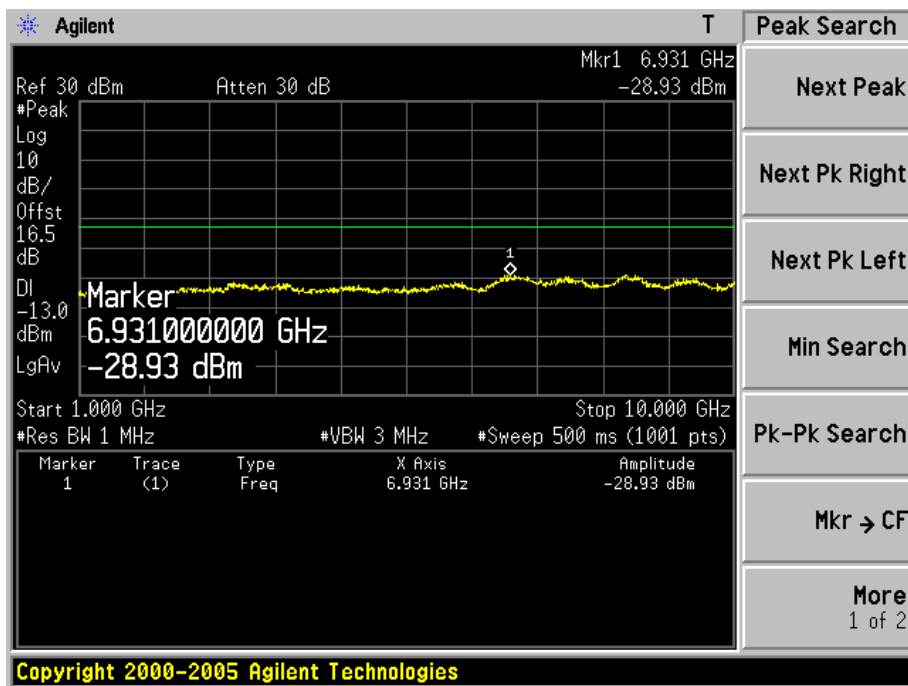
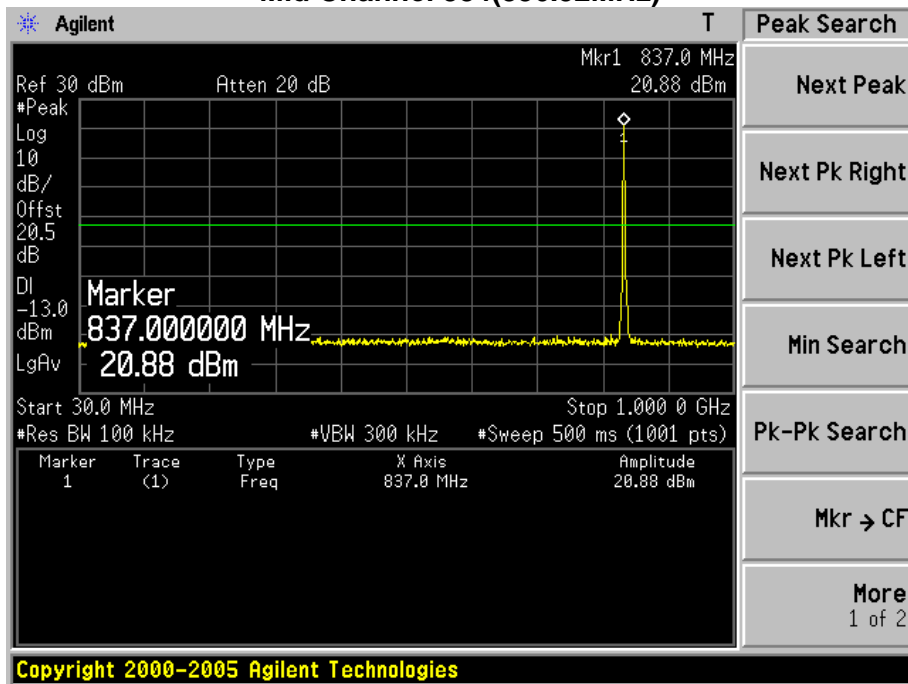

High Channel 777(848.31MHz)

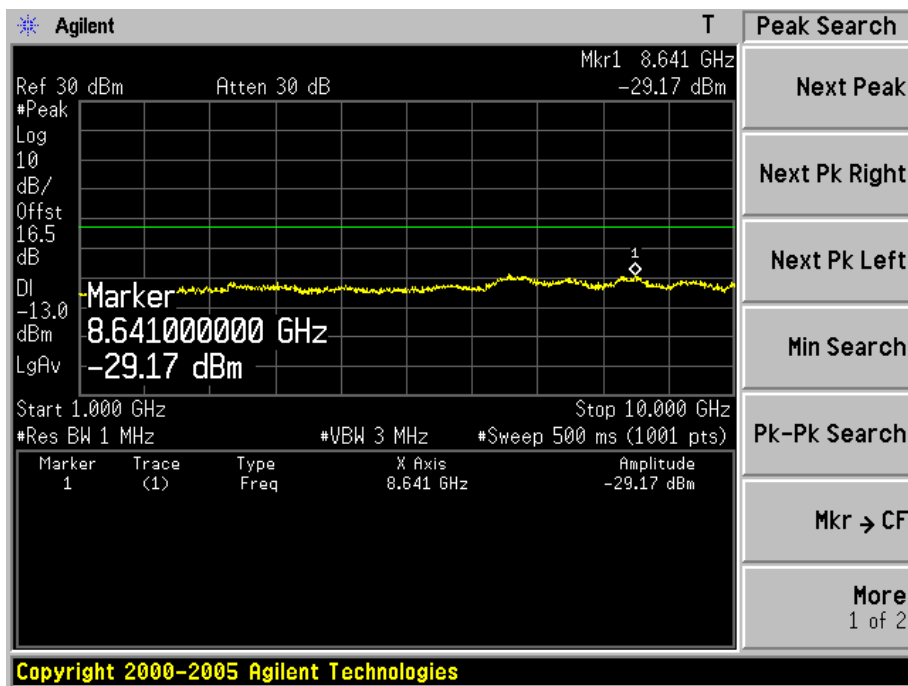
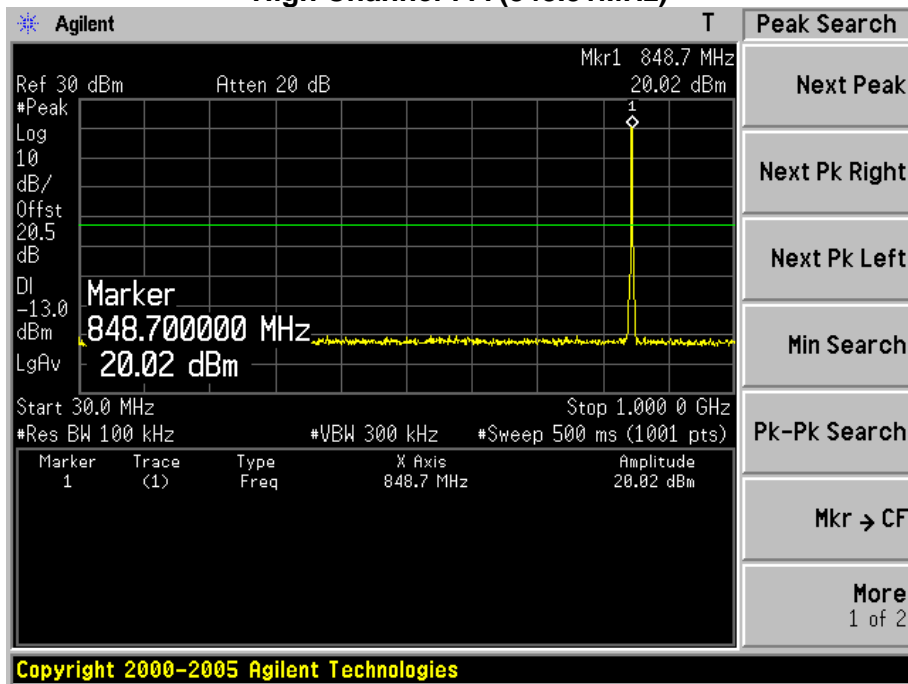

Product	Wireless Module		
Test Item	Conducted Spurious Emission		
Test Mode	Mode 2: CDMA 2000 1X BC1 Link		
Date of Test	2015/01/16	Test Site	TR-8

Low Channel 25(1851.25MHz)

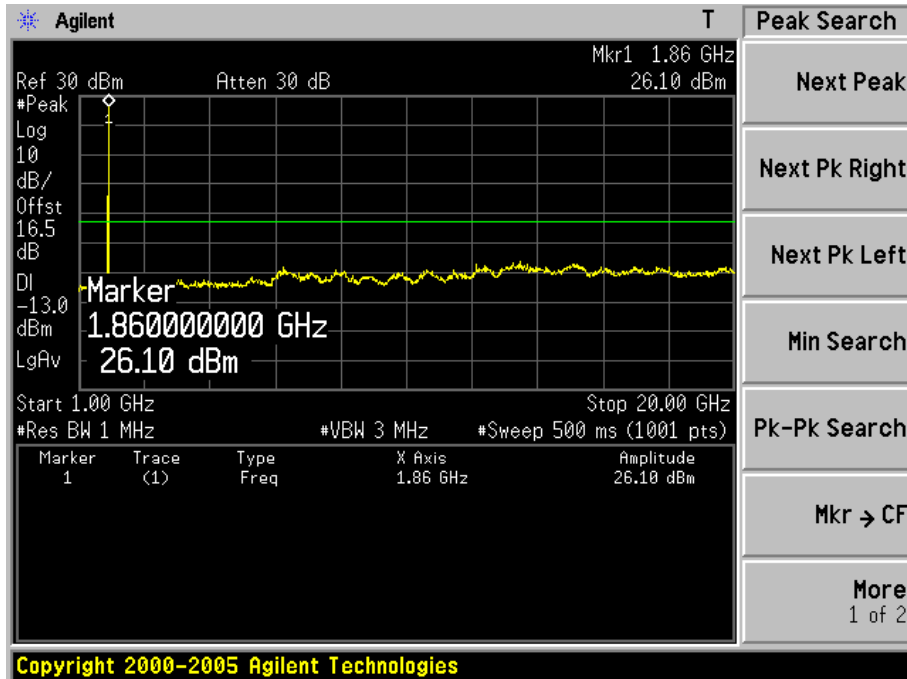
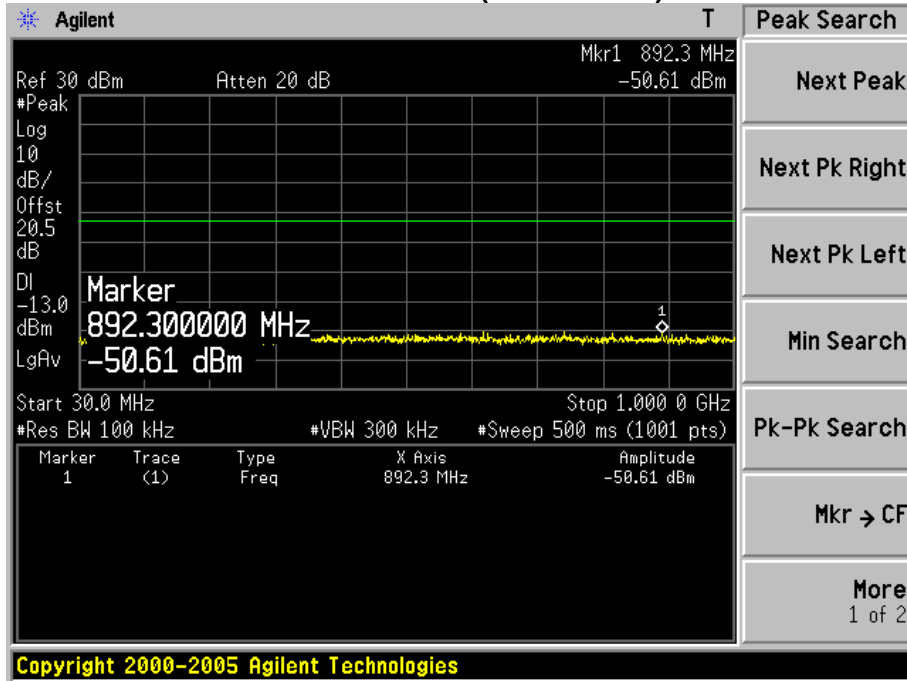

Mid Channel 600(1880MHz)

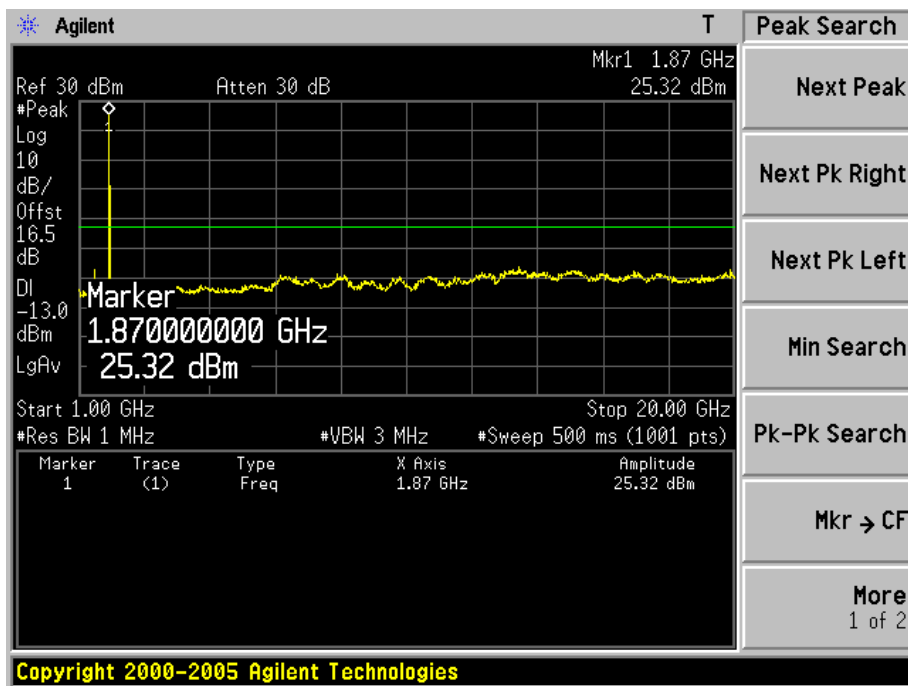
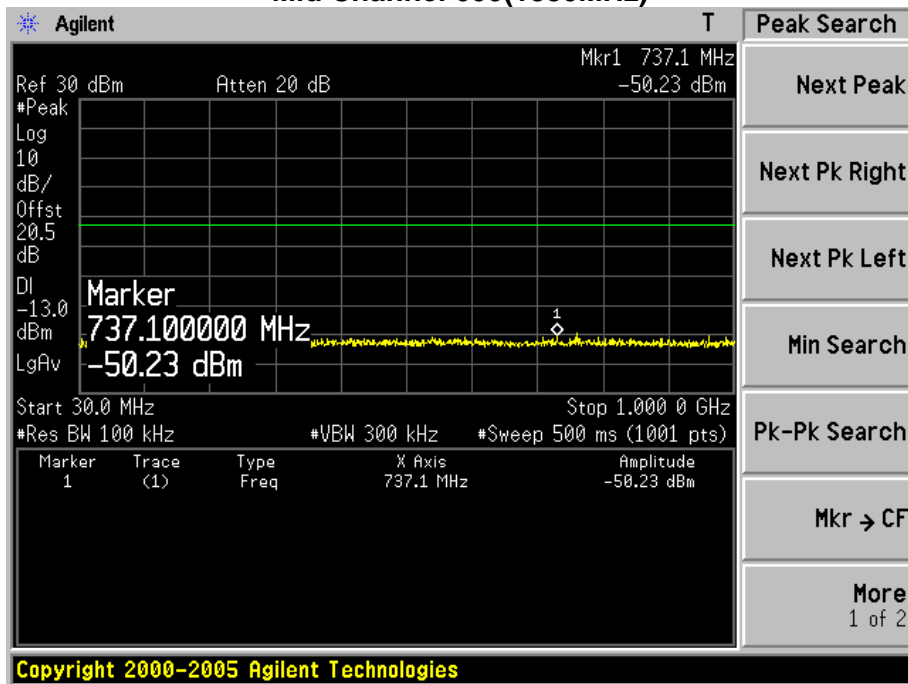

High Channel 1175(1908.75MHz)

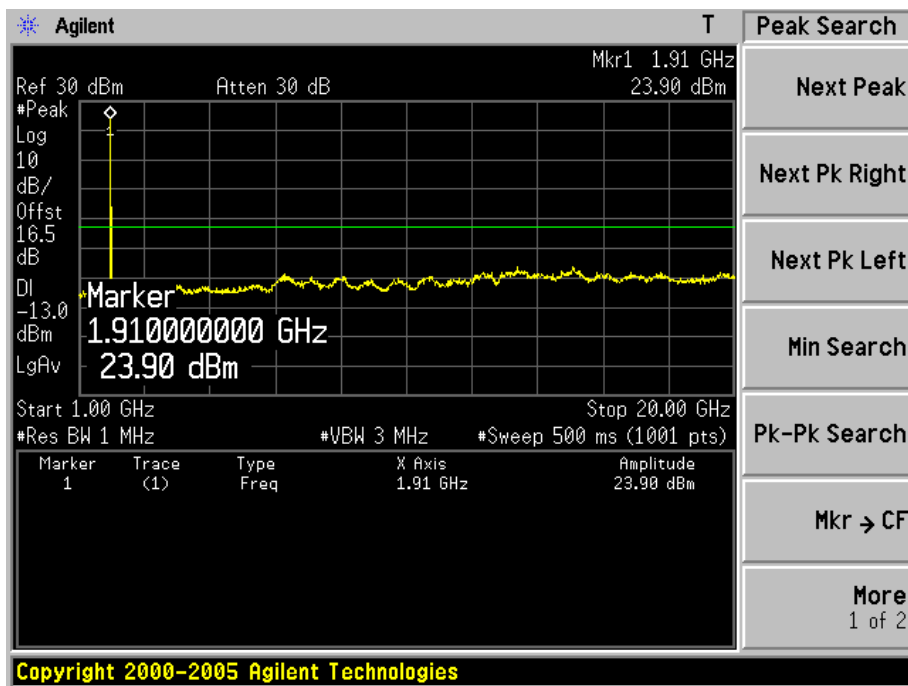
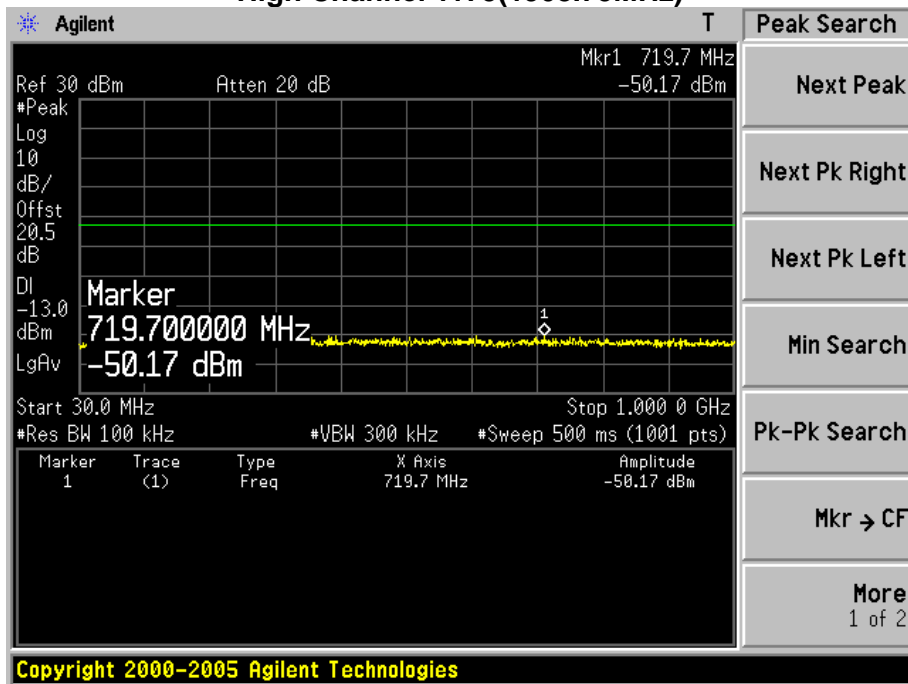

Product	Wireless Module		
Test Item	Conducted Spurious Emission		
Test Mode	Mode 3: CDMA 2000 1X BC10 Link		
Date of Test	2015/02/09	Test Site	TR-8

Low Channel 476(817.90MHz)

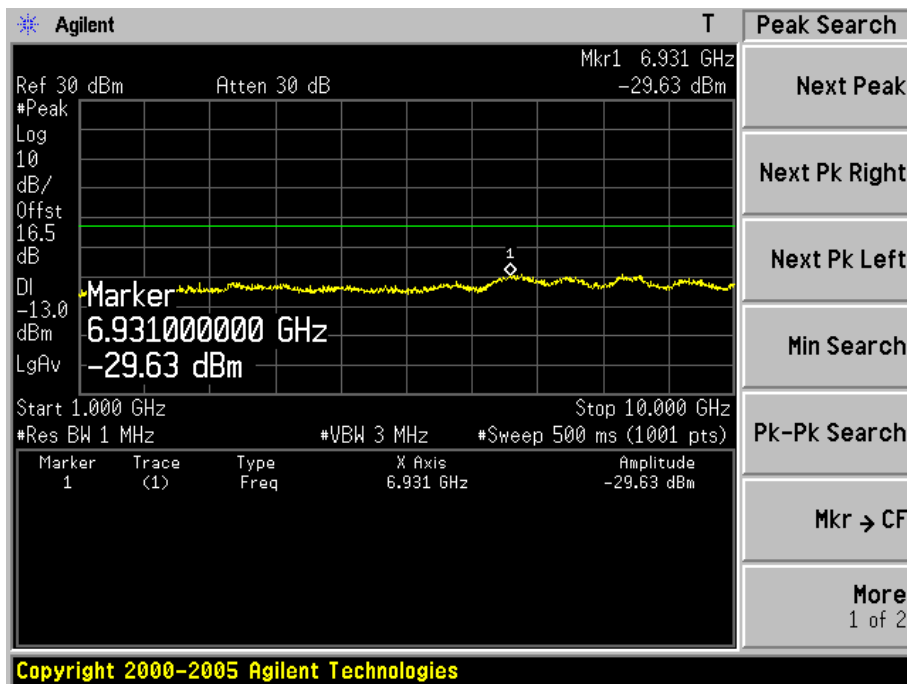
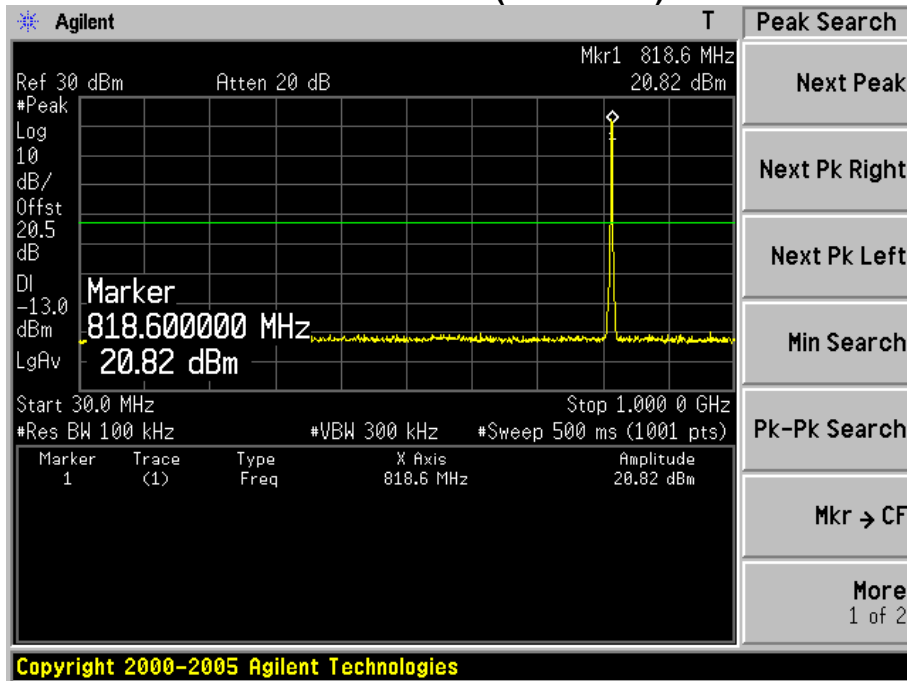

Mid Channel 580(820.50MHz)

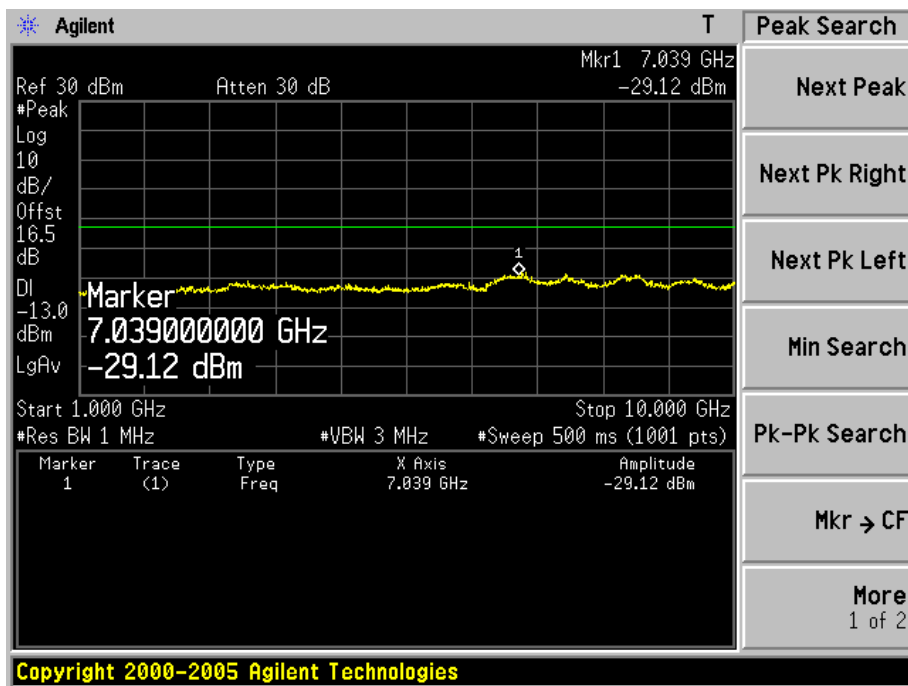
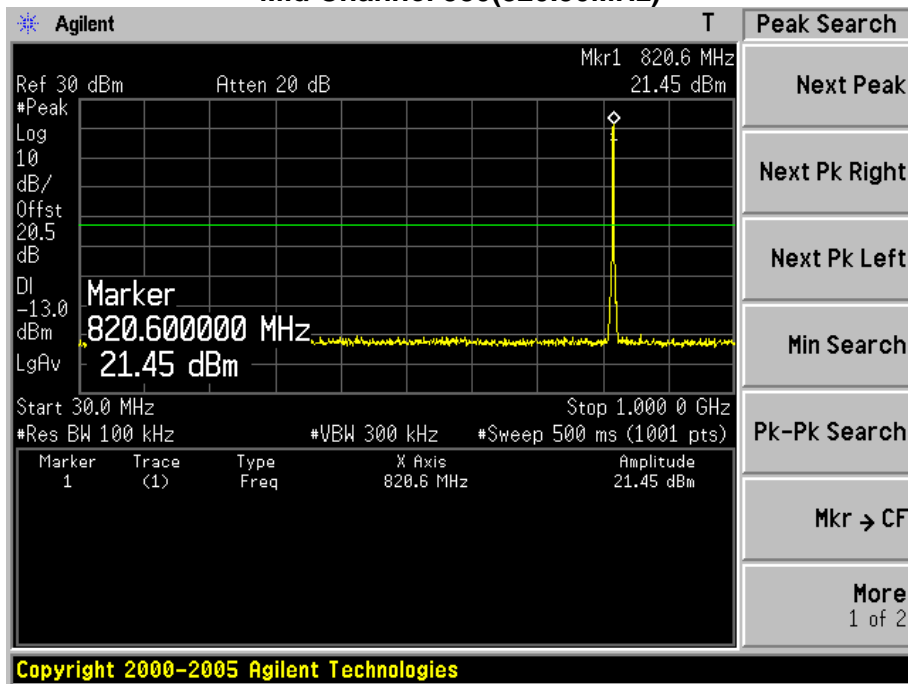

High Channel 684(823.10MHz)

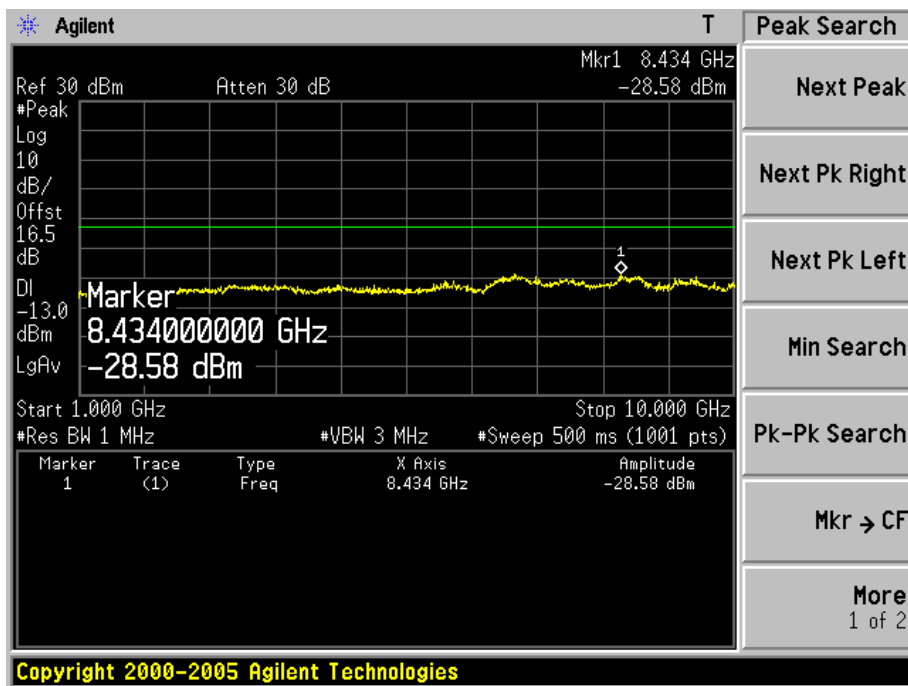
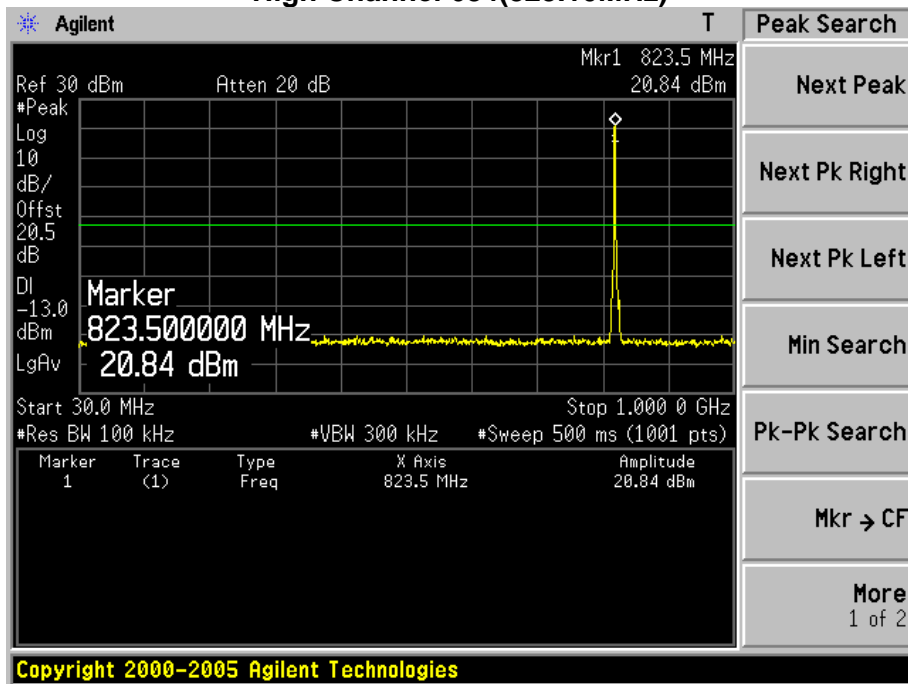

Product	Wireless Module		
Test Item	Conducted Spurious Emission		
Test Mode	Mode 4: CDMA 2000 1XEVD0 Rel-0 BC0 Link		
Date of Test	2015/01/16	Test Site	TR-8

Low Channel 1013(824.7MHz)

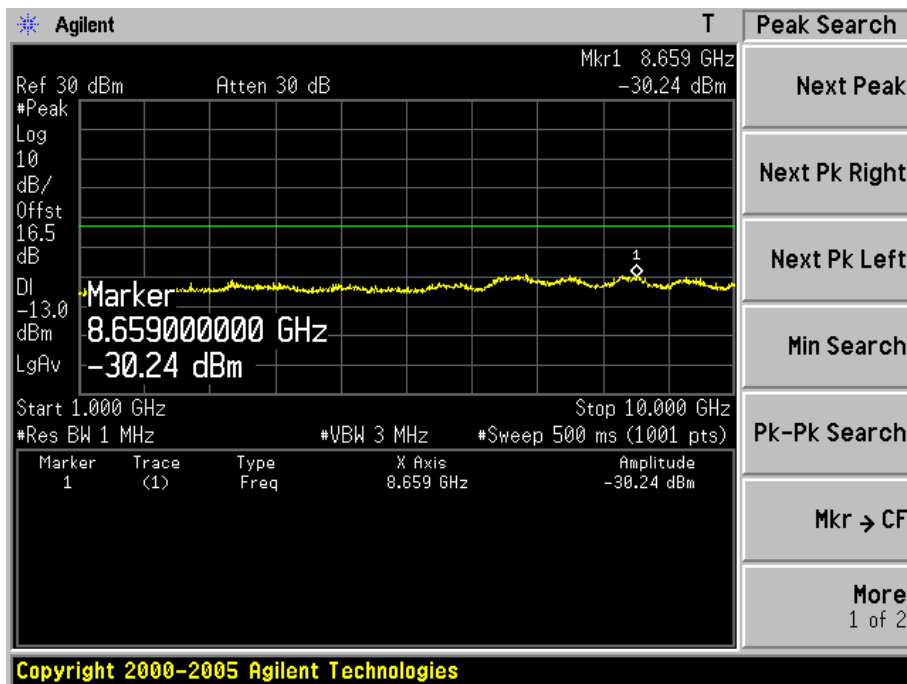
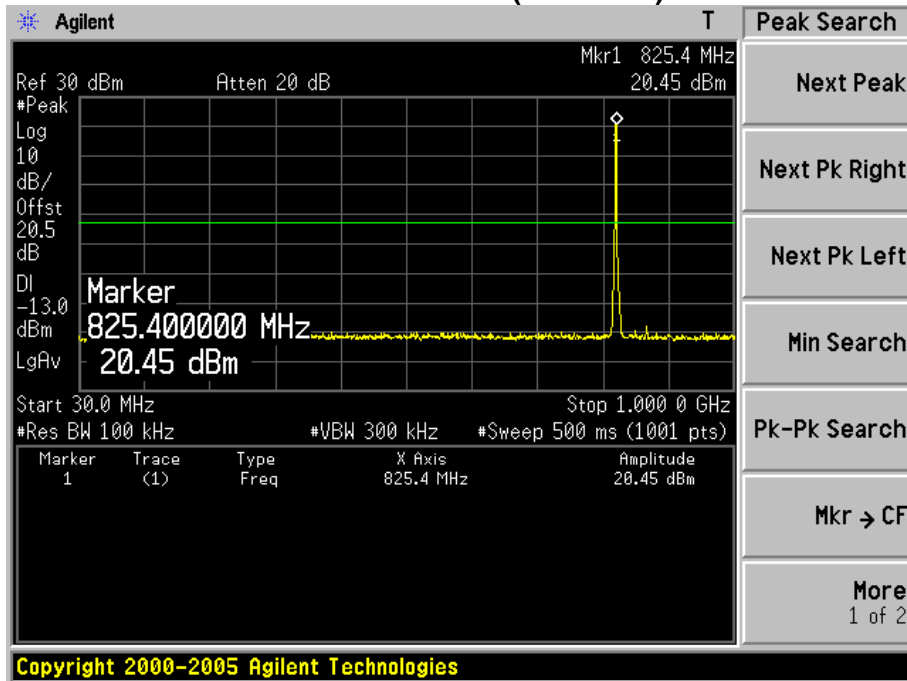

Mid Channel 384(836.52MHz)

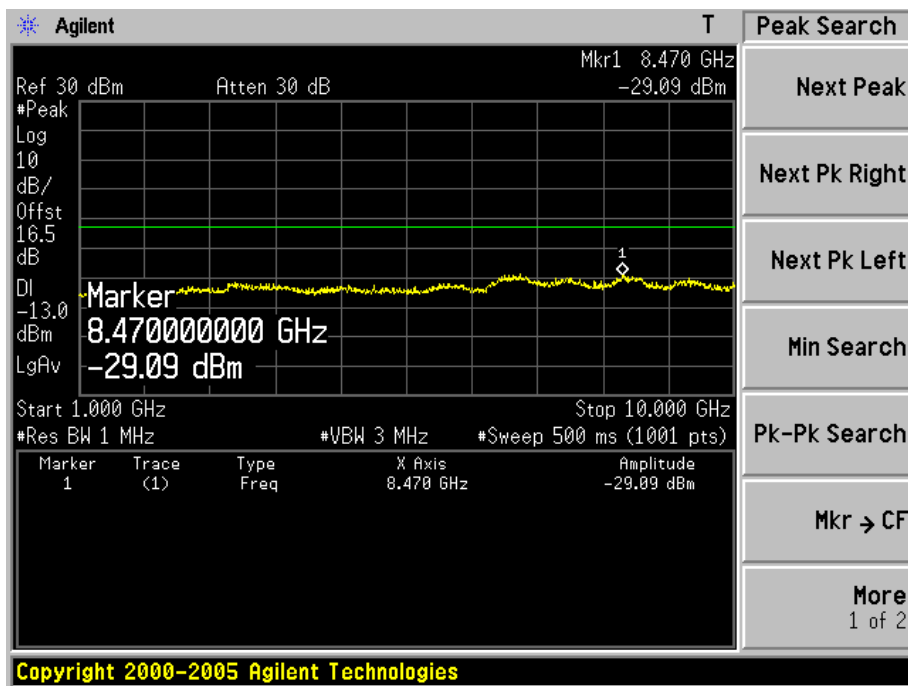
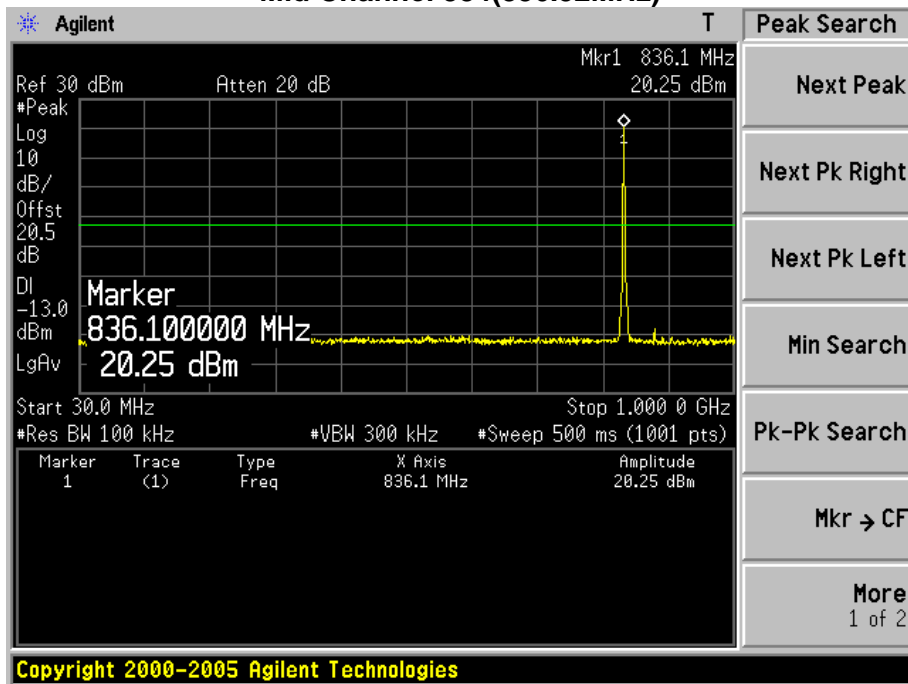

High Channel 777(848.31MHz)

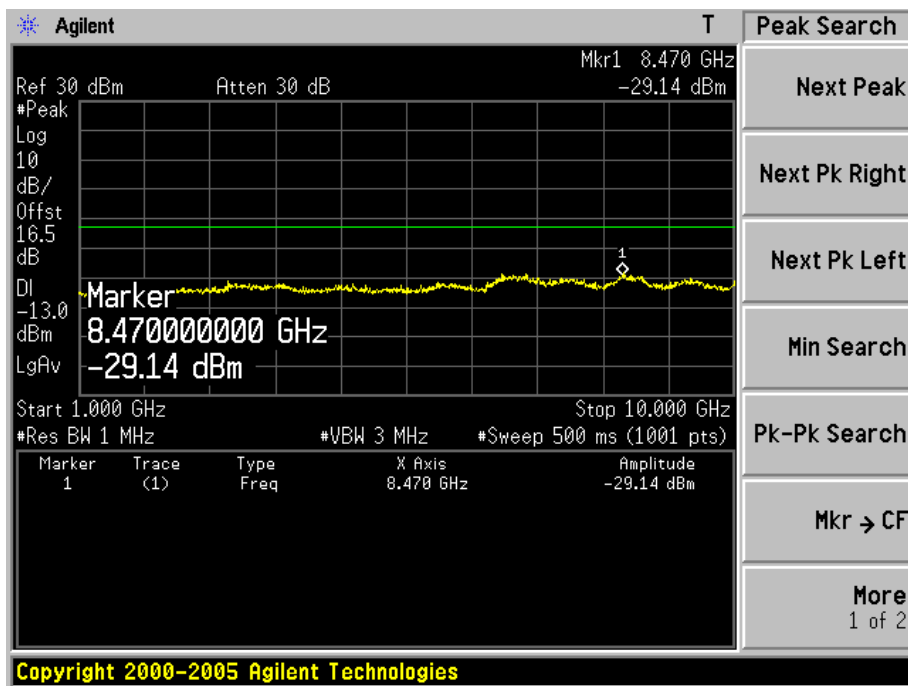
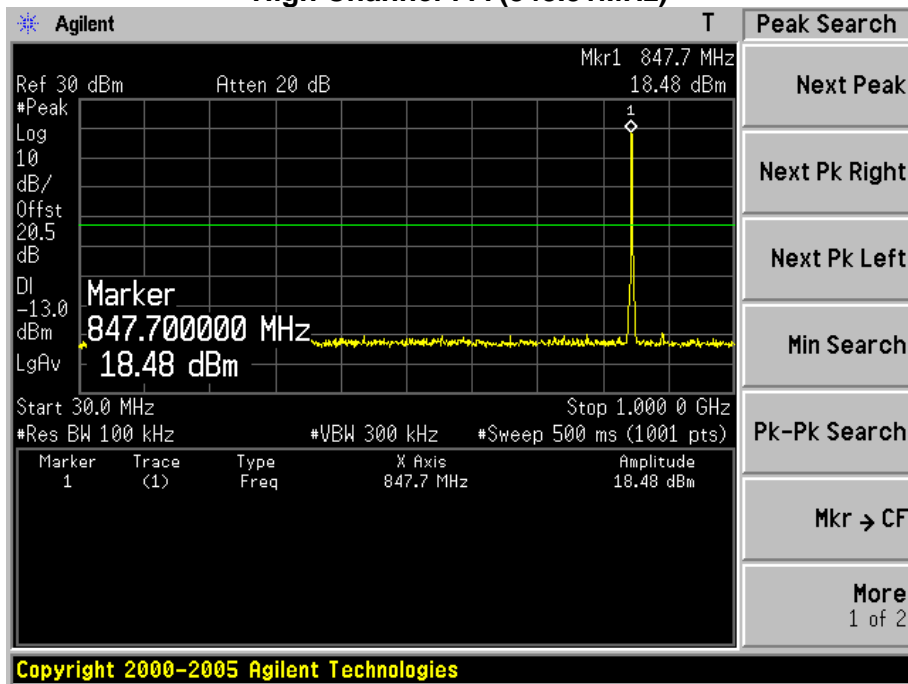

Product	Wireless Module		
Test Item	Conducted Spurious Emission		
Test Mode	Mode 5: CDMA 2000 1XEVD0 Rel-0 BC1 Link		
Date of Test	2015/01/16	Test Site	TR-8

Low Channel 25(1851.25MHz)

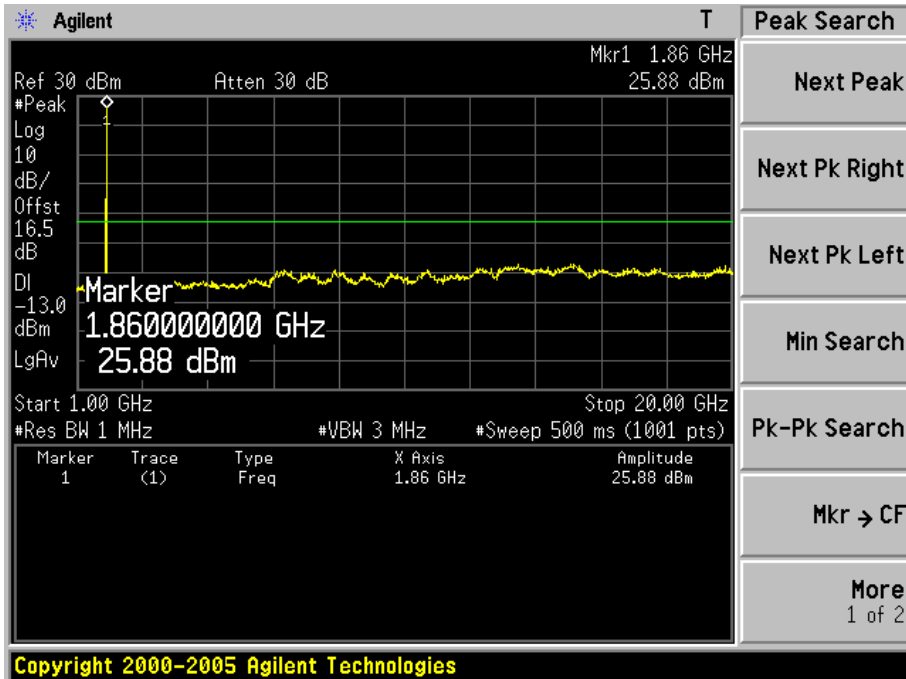
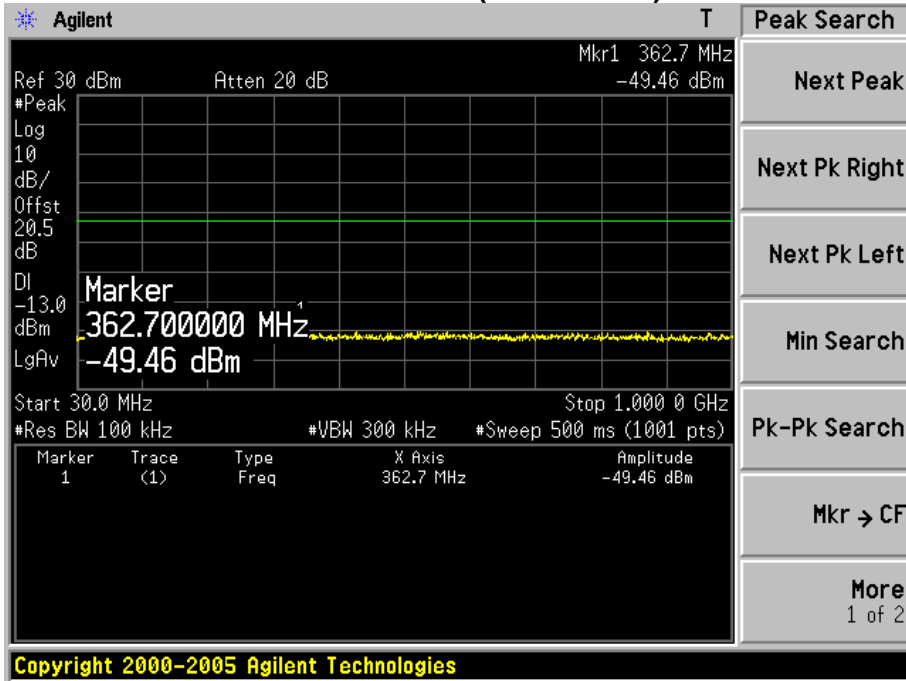

Mid Channel 600(1880MHz)

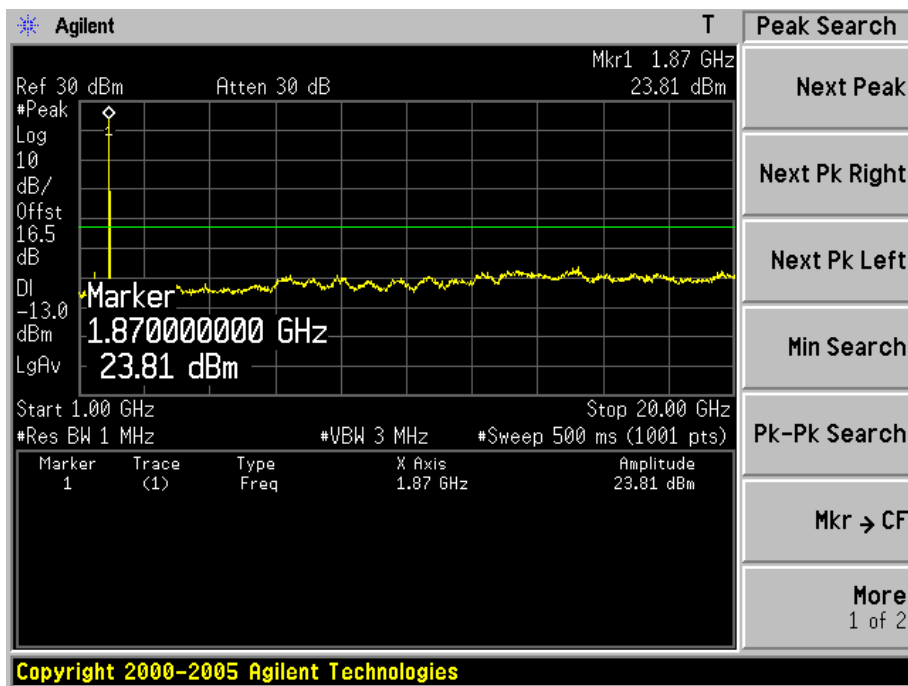
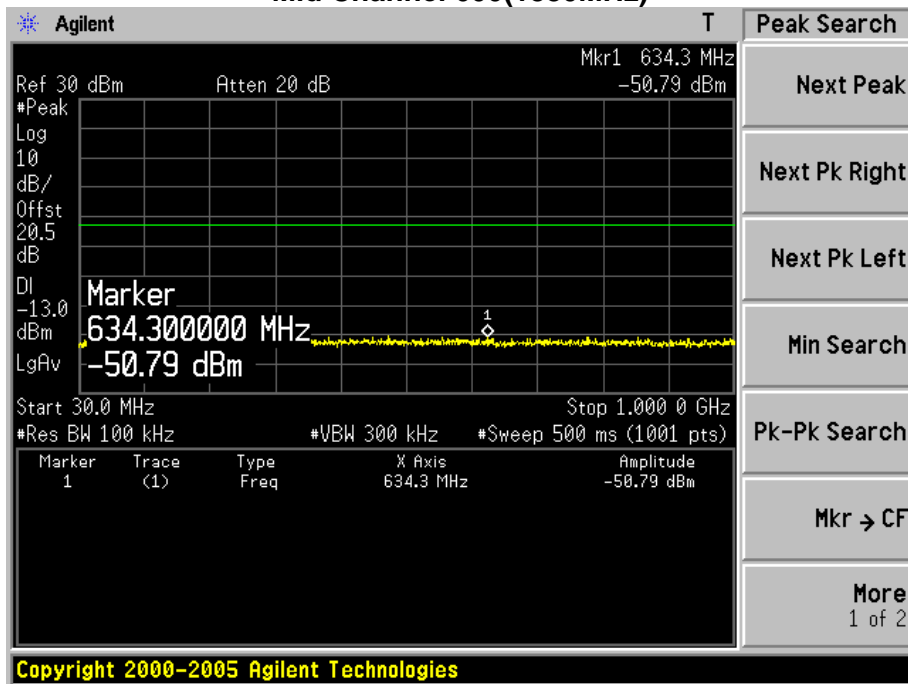

High Channel 1175(1908.75MHz)

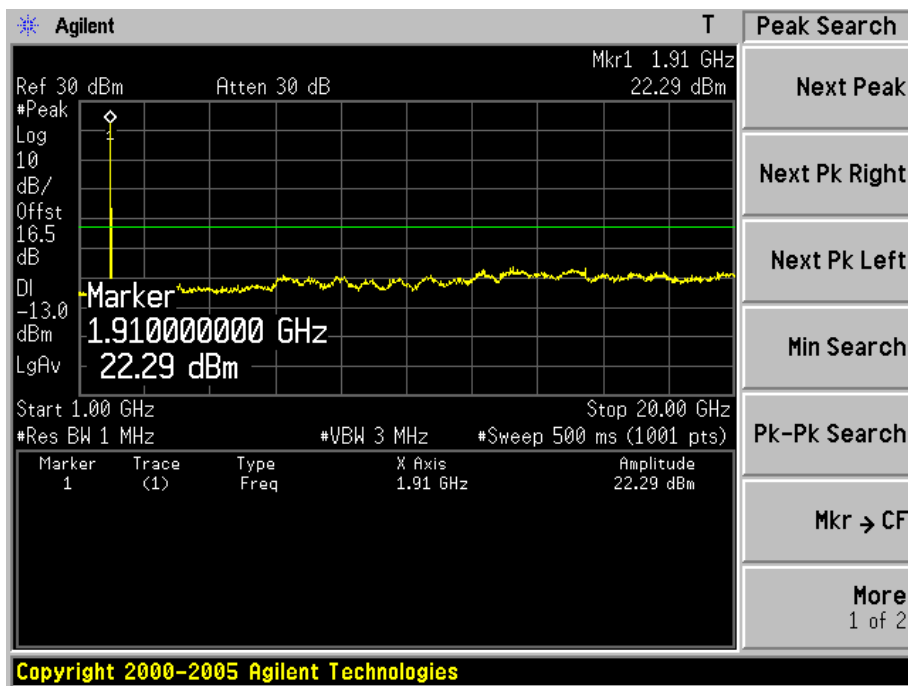
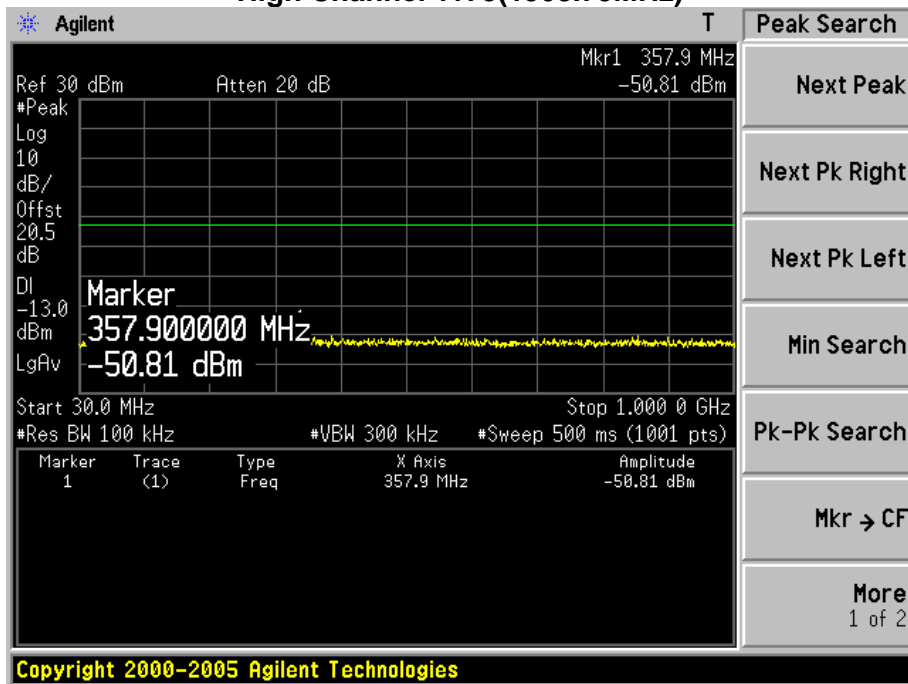

Product	Wireless Module		
Test Item	Conducted Spurious Emission		
Test Mode	Mode 6: CDMA 2000 1XEVD0 Rel-0 BC10 Link		
Date of Test	2015/02/09	Test Site	TR-8

Low Channel 476(817.90MHz)

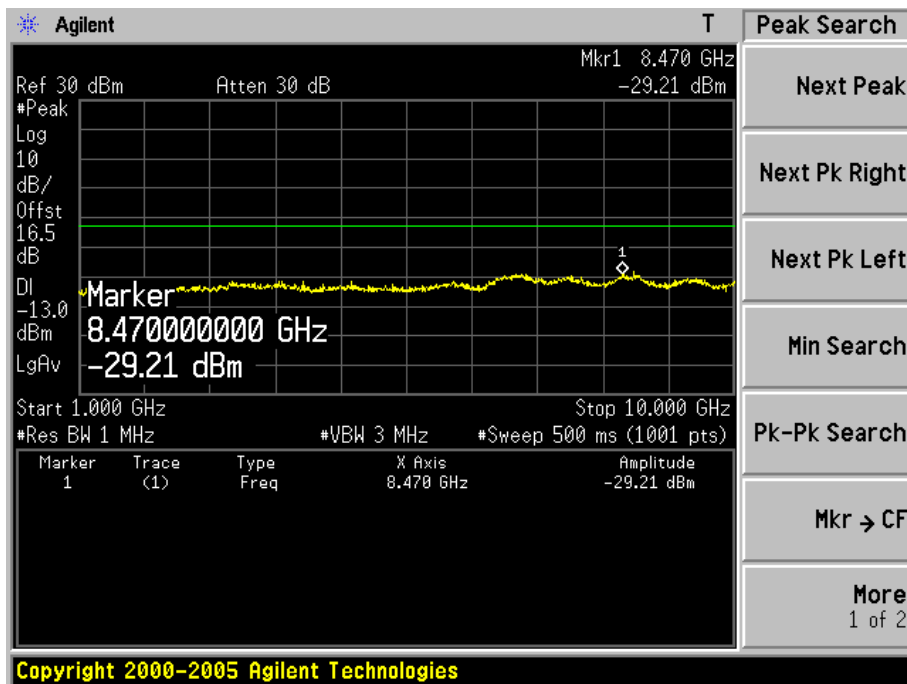
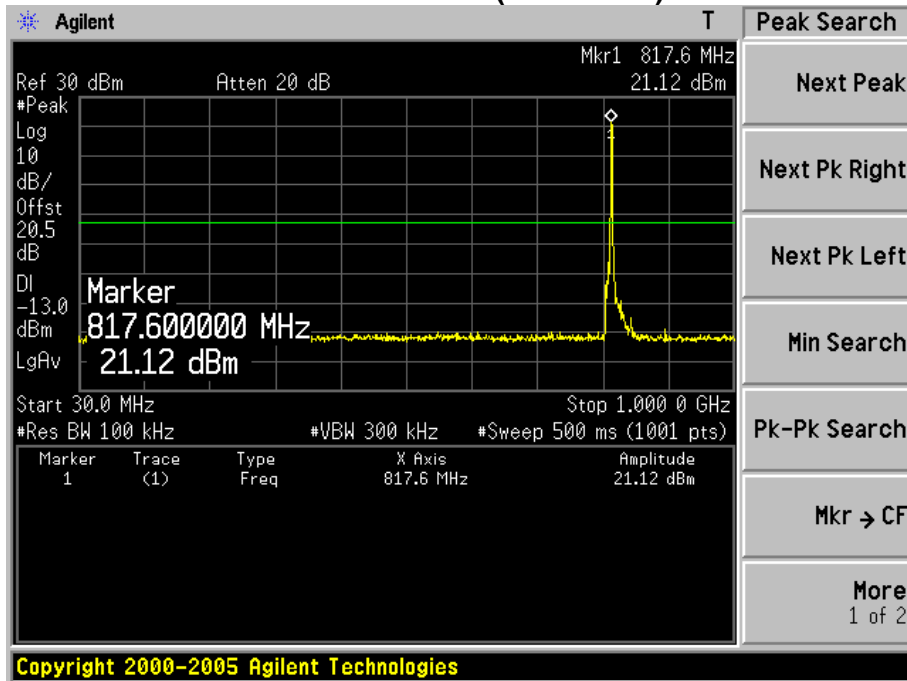

Mid Channel 580(820.50MHz)

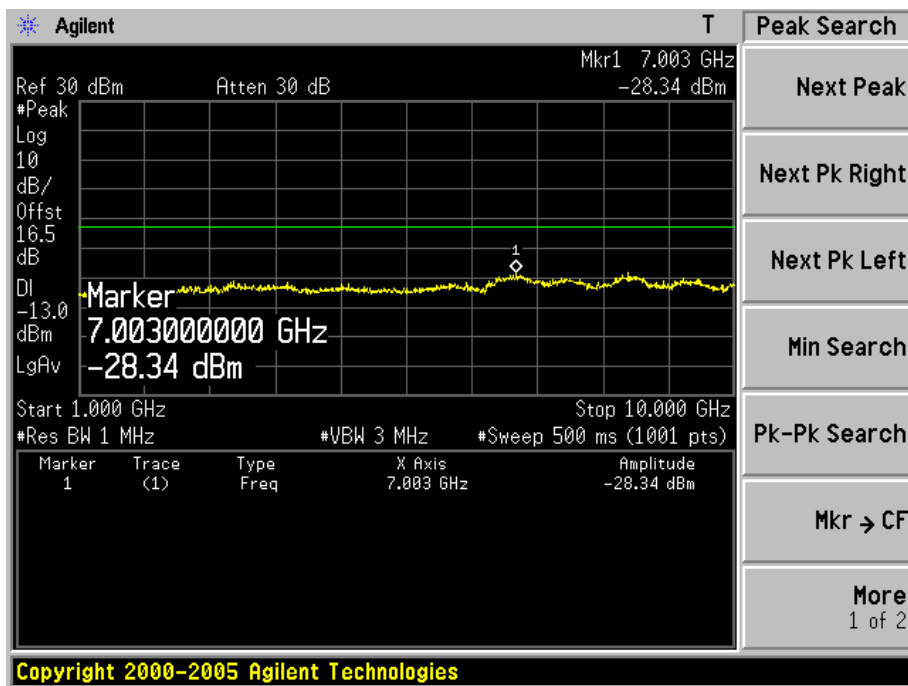
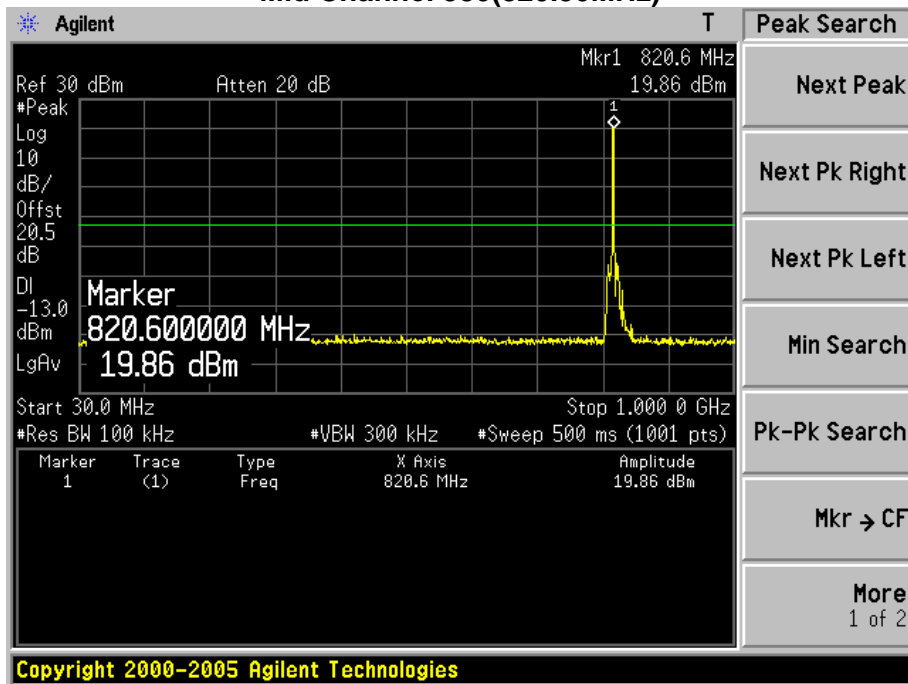

High Channel 684(823.10MHz)

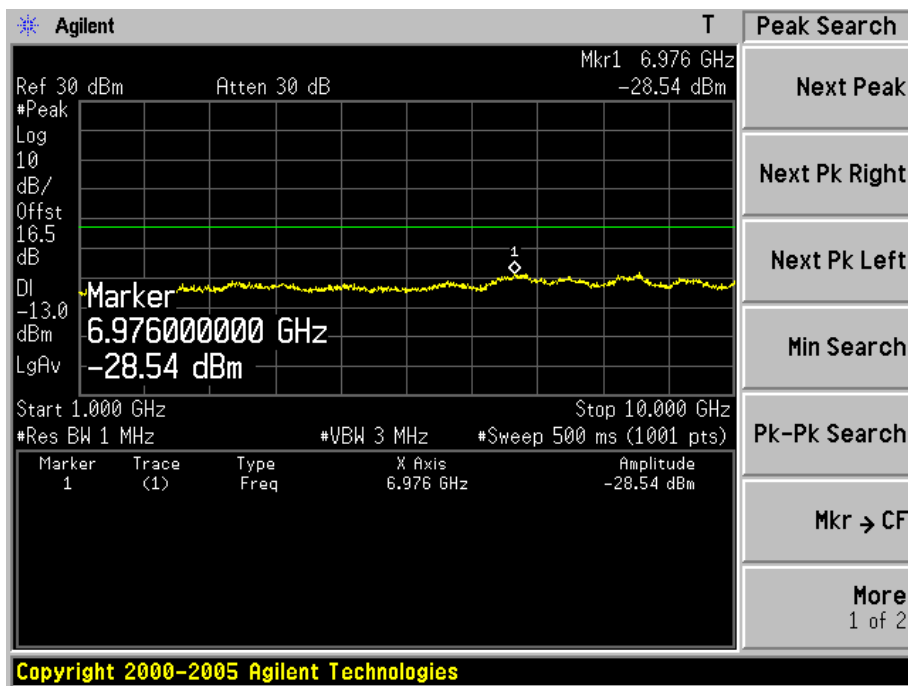
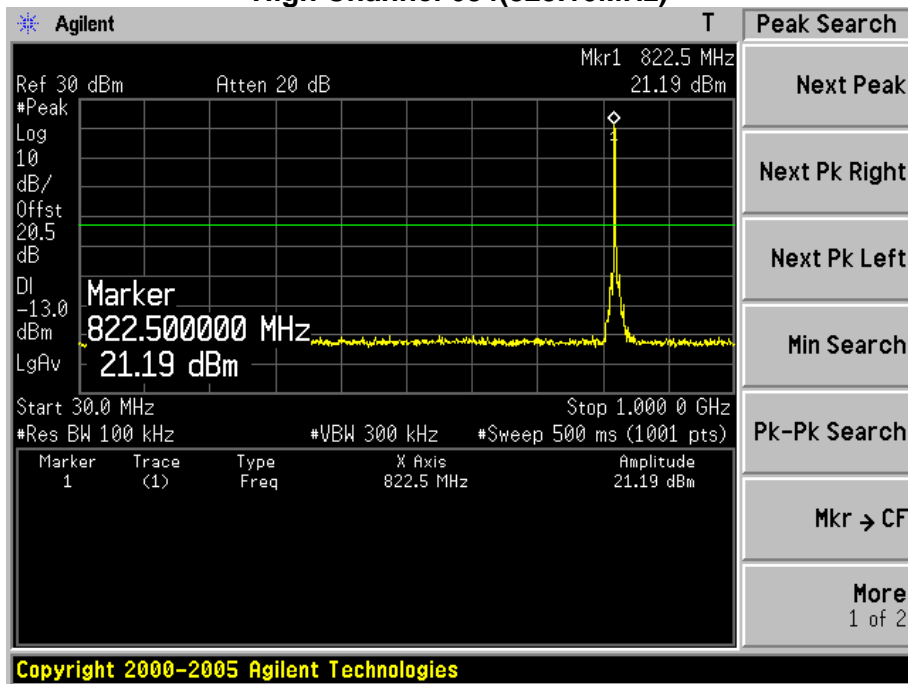

Product	Wireless Module		
Test Item	Conducted Spurious Emission		
Test Mode	Mode 7: CDMA 2000 1XEVD0 Rel-A BC0 Link		
Date of Test	2015/01/16	Test Site	TR-8

Low Channel 1013(824.7MHz)

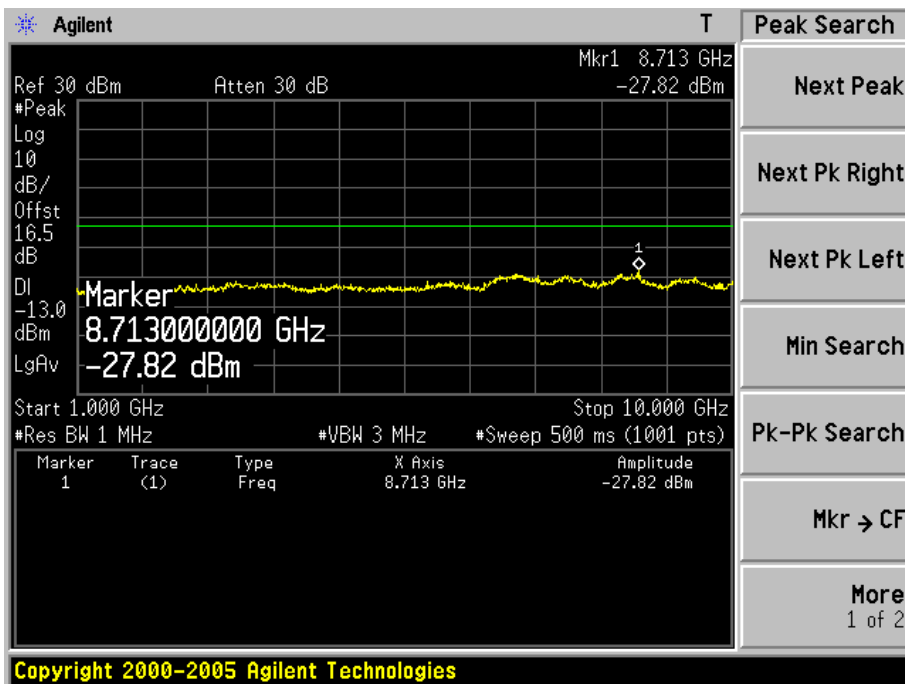
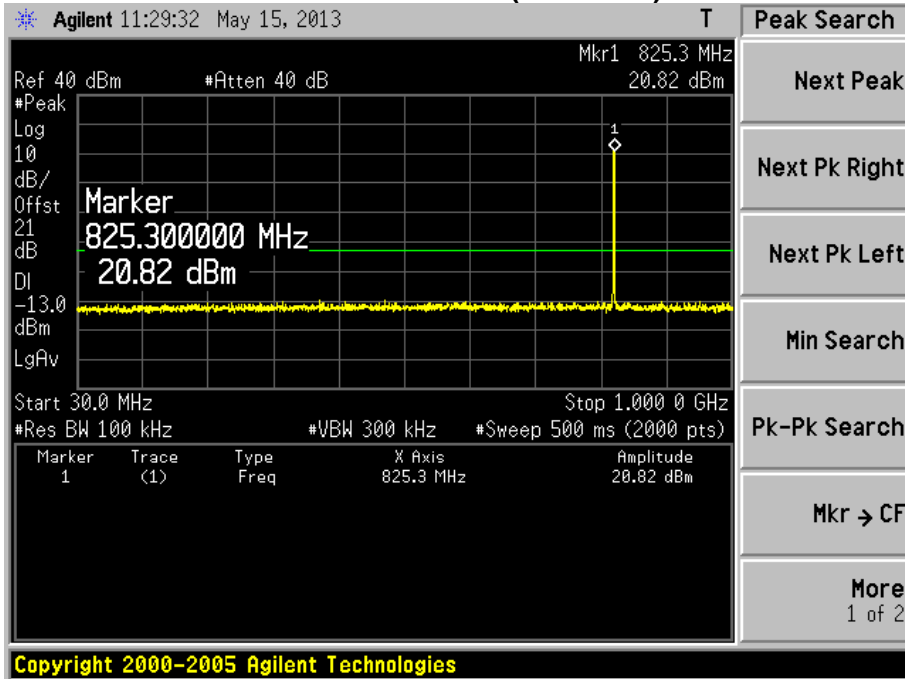

Mid Channel 384(836.52MHz)

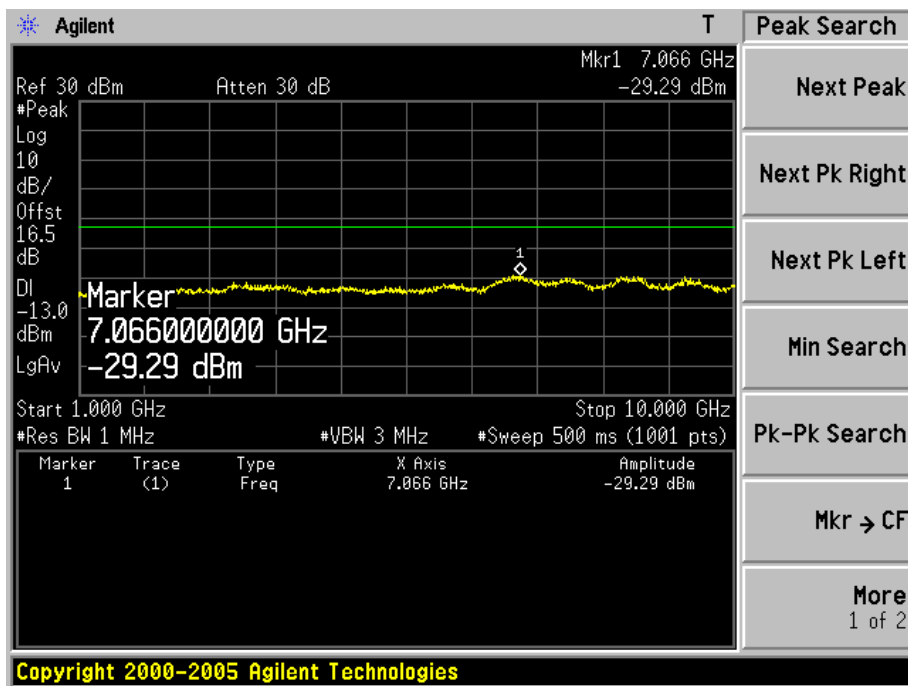
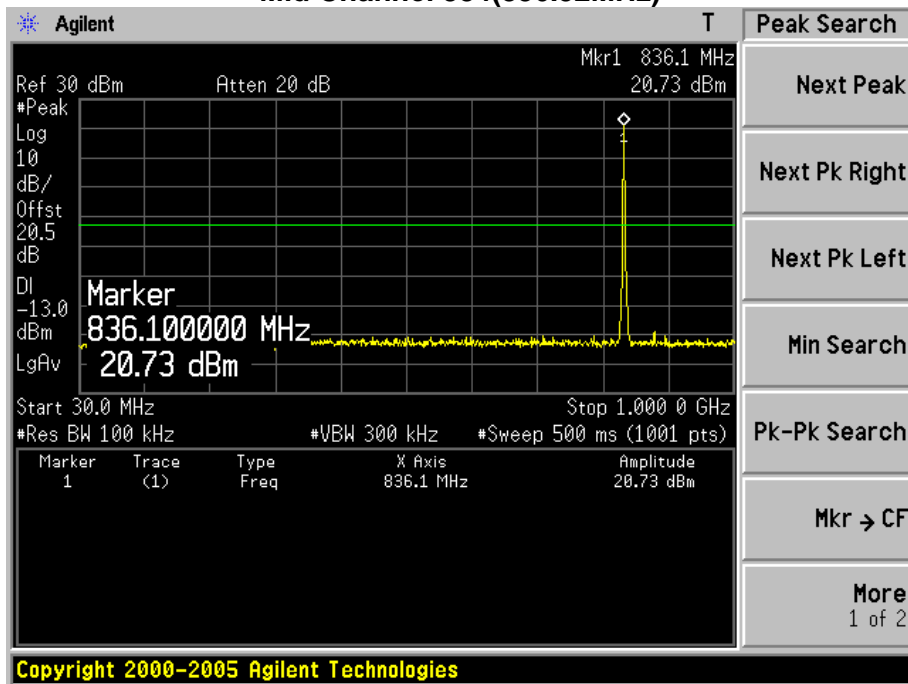

High Channel 777(848.31MHz)

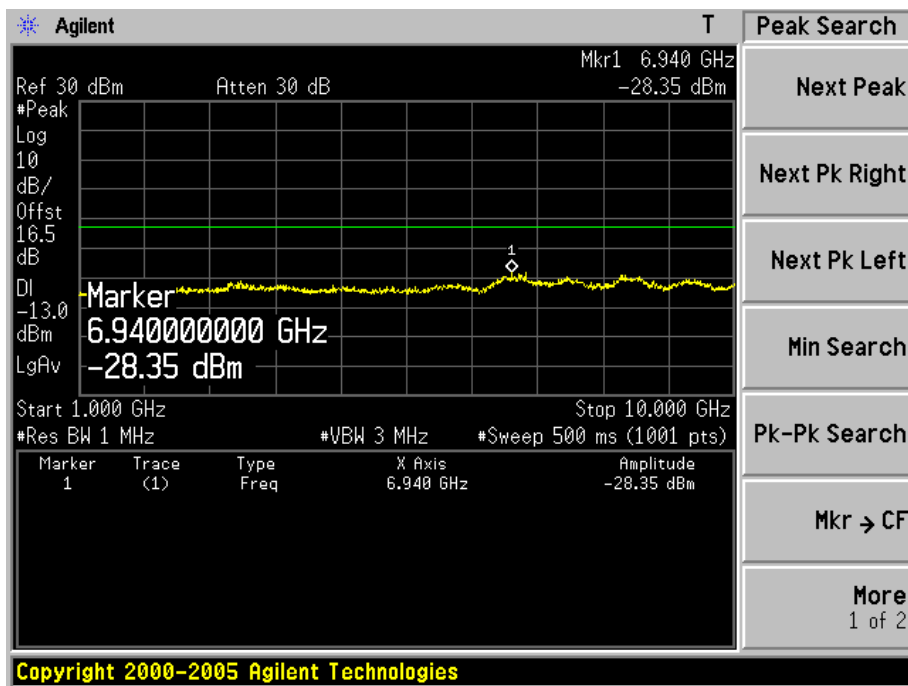
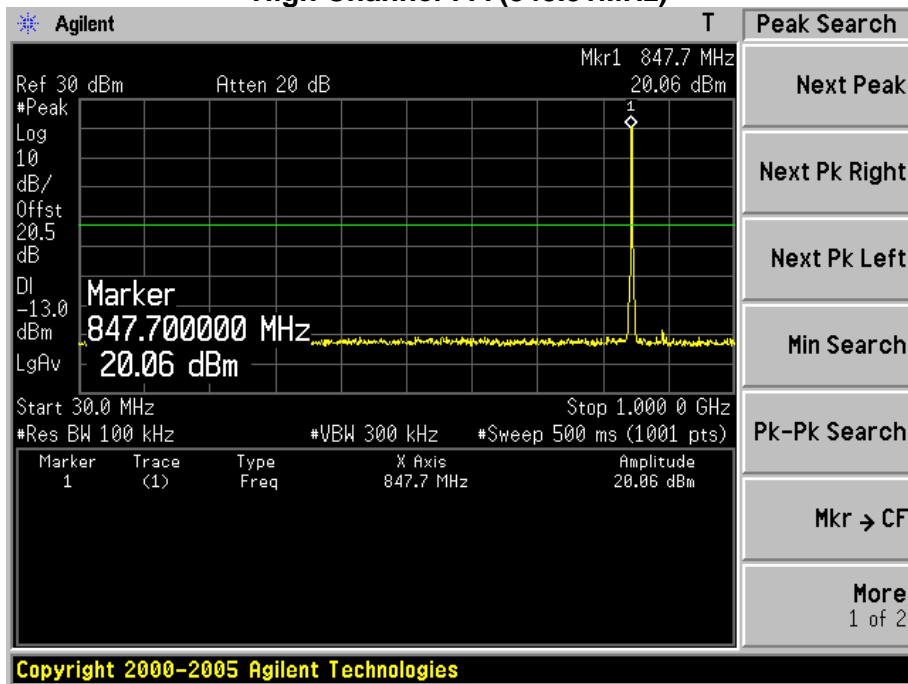

Product	Wireless Module		
Test Item	Conducted Spurious Emission		
Test Mode	Mode 8: CDMA 2000 1XEVD0 Rel-A BC1 Link		
Date of Test	2015/01/16	Test Site	TR-8

Low Channel 25(1851.25MHz)

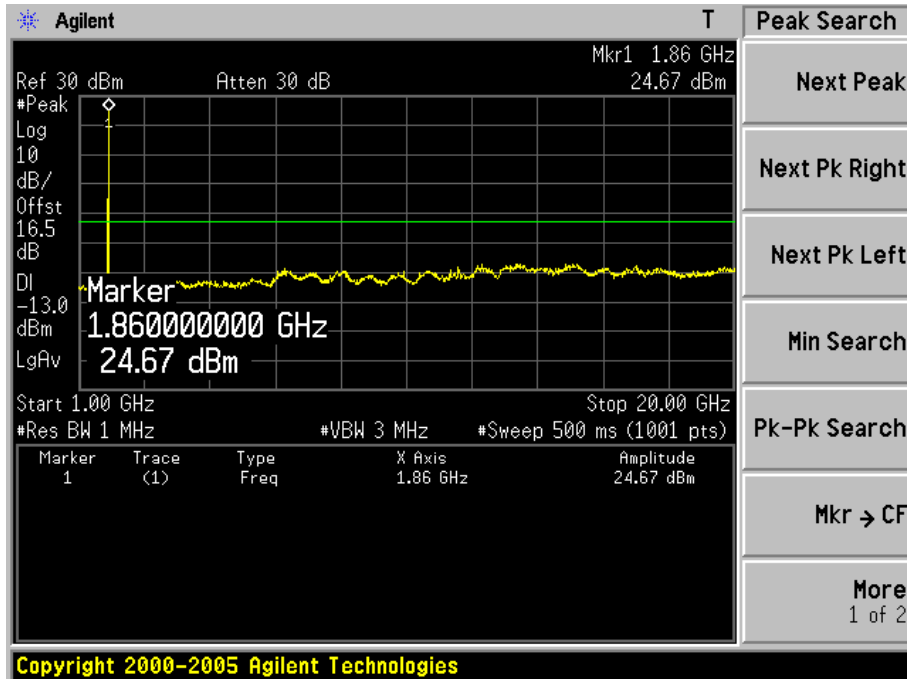
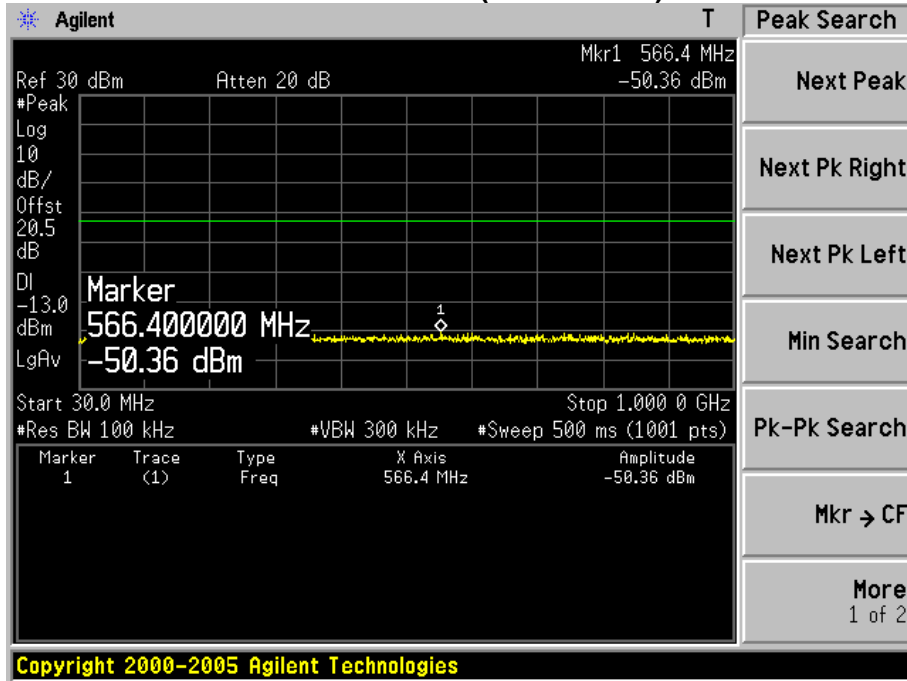

Mid Channel 600(1880MHz)

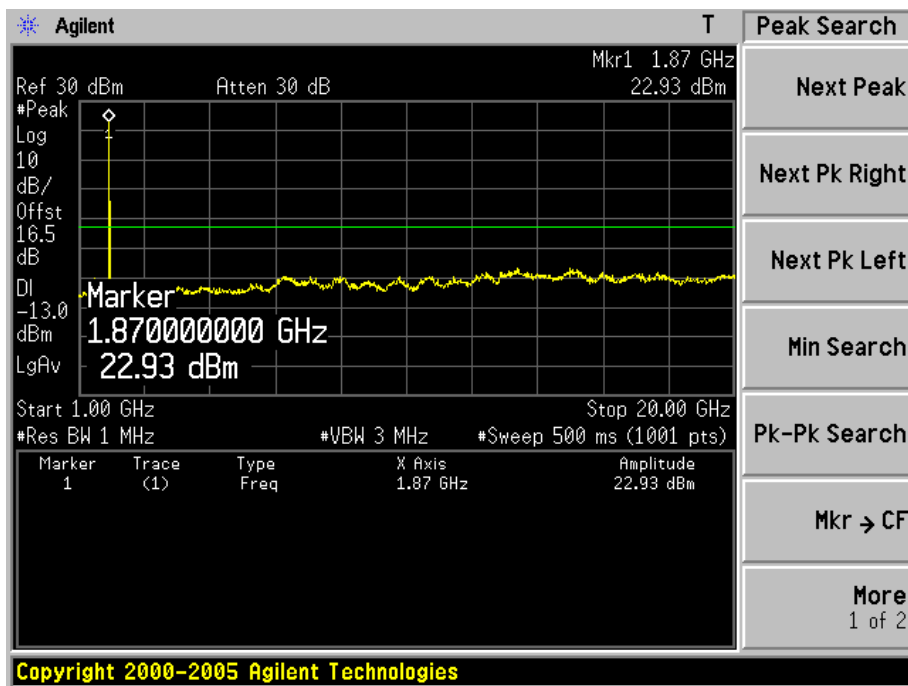
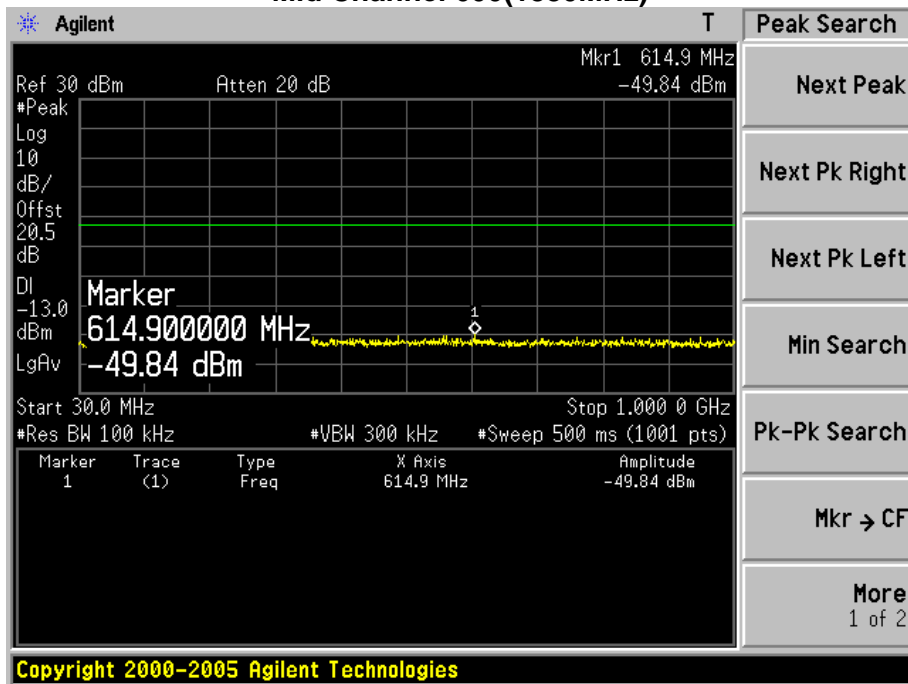

High Channel 1175(1908.75MHz)

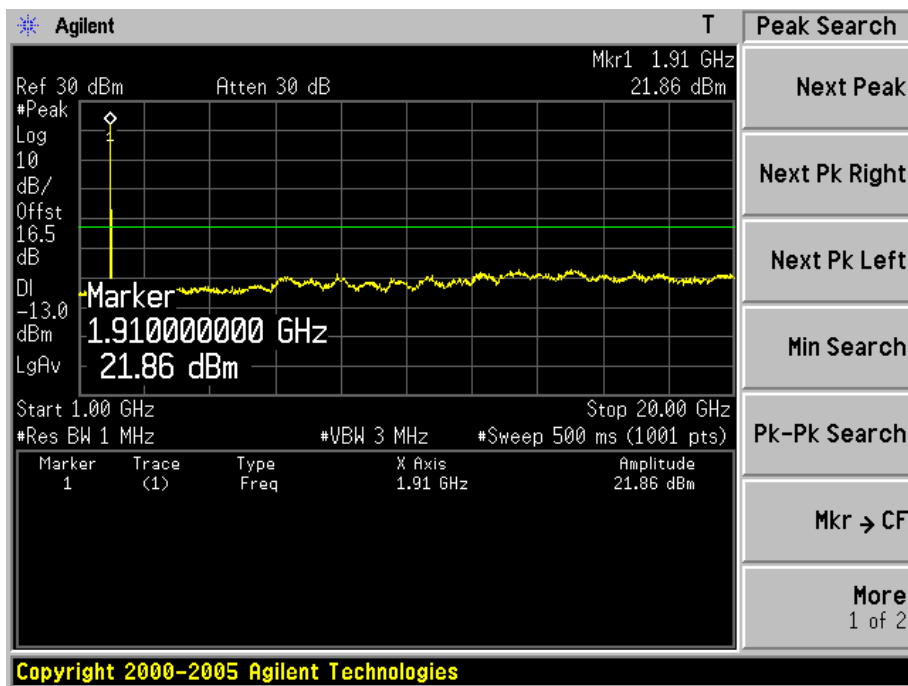
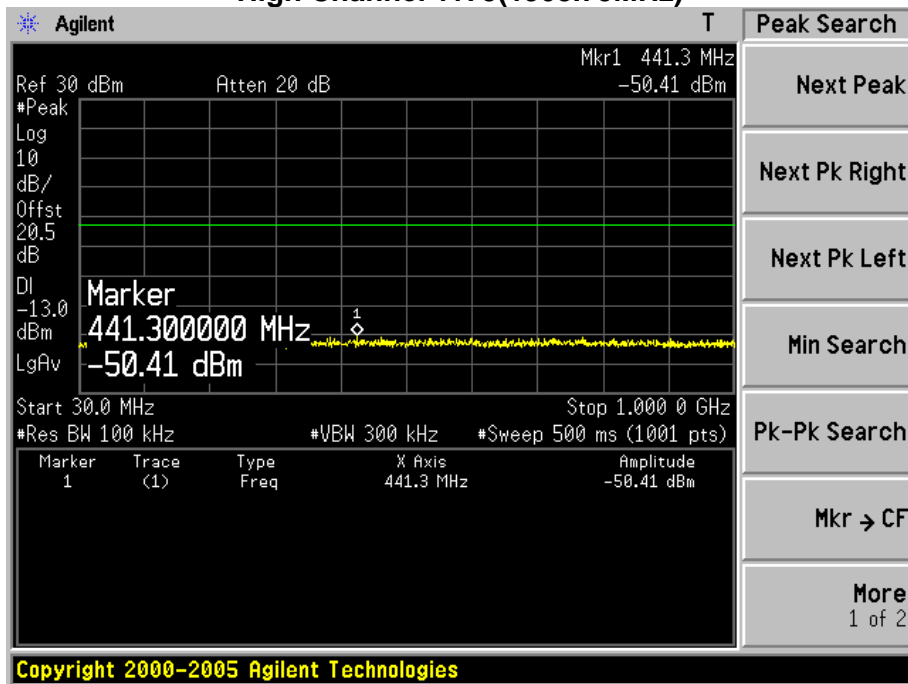

Product	Wireless Module		
Test Item	Conducted Spurious Emission		
Test Mode	Mode 9: CDMA 2000 1XEVD0 Rel-A BC10 Link		
Date of Test	2015/02/09	Test Site	TR-8

Low Channel 476(817.90MHz)

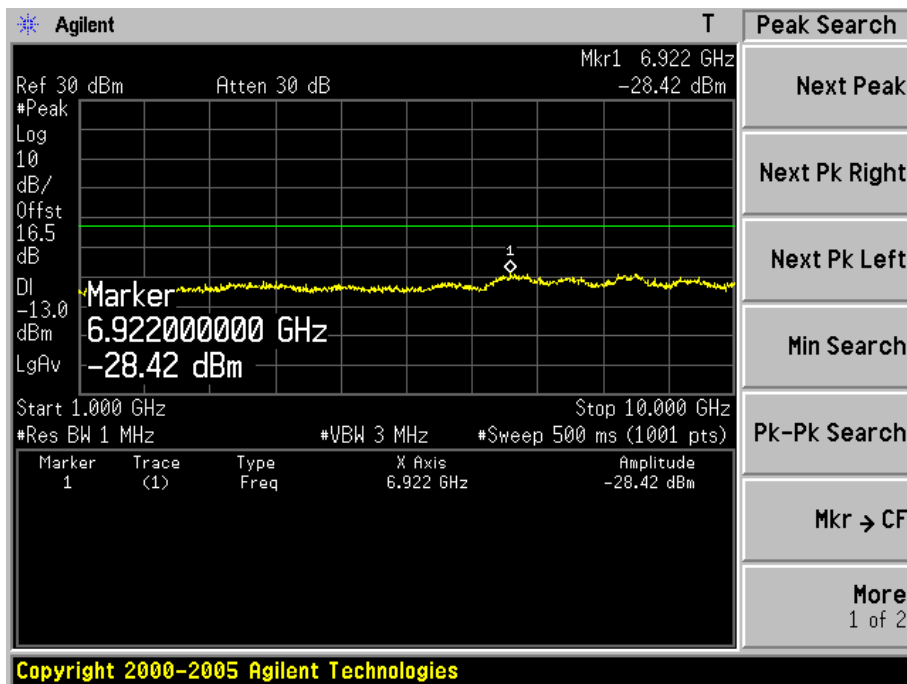
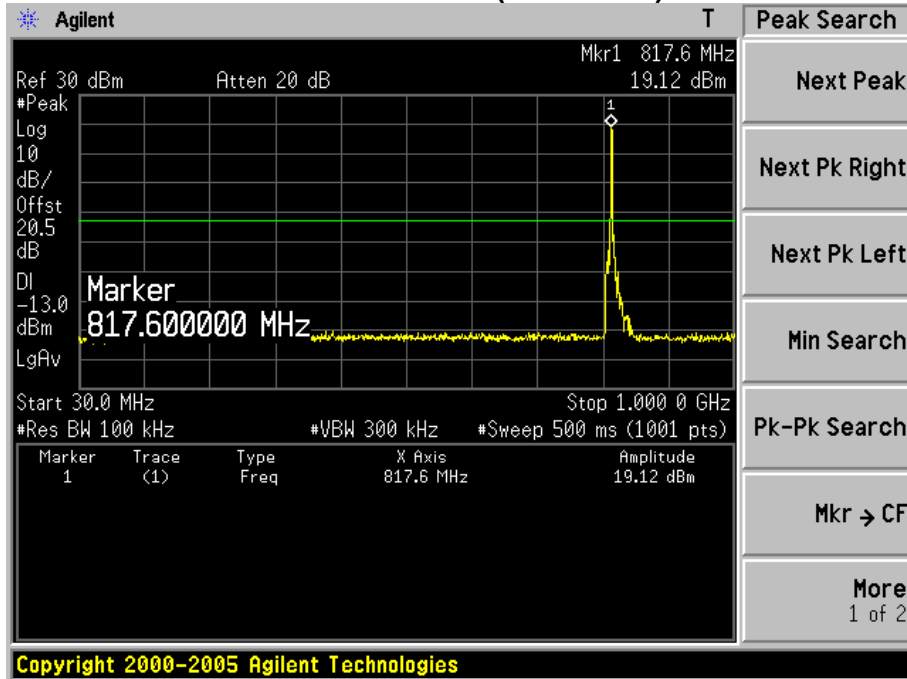

Mid Channel 580(820.50MHz)

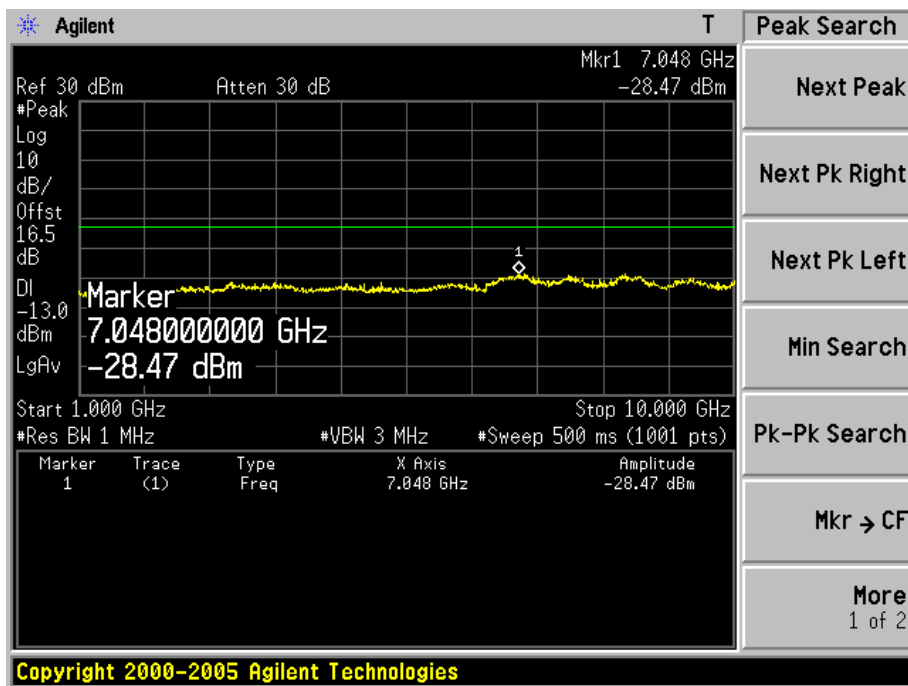
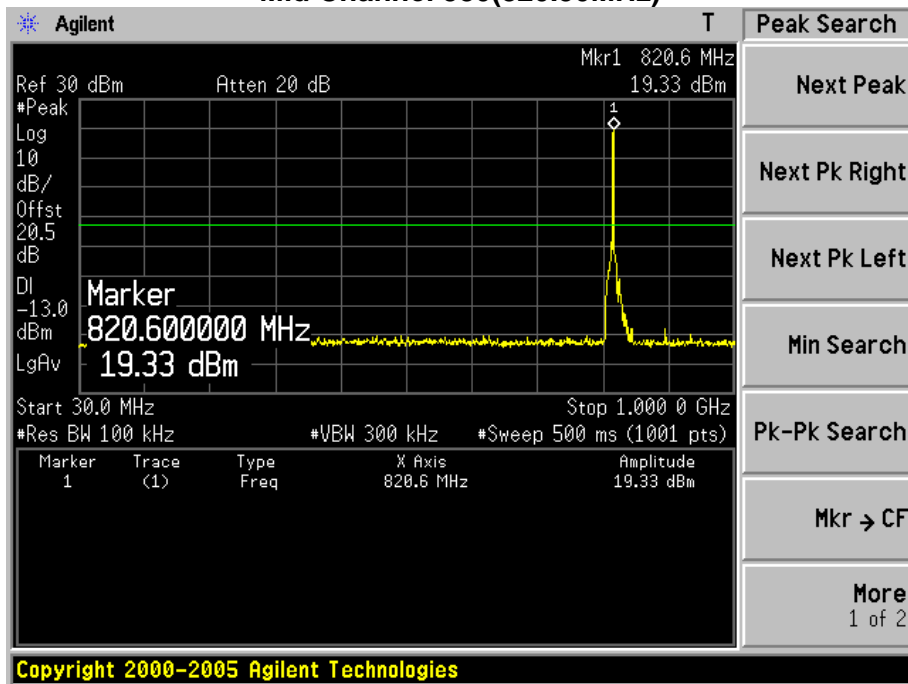

High Channel 684(823.10MHz)

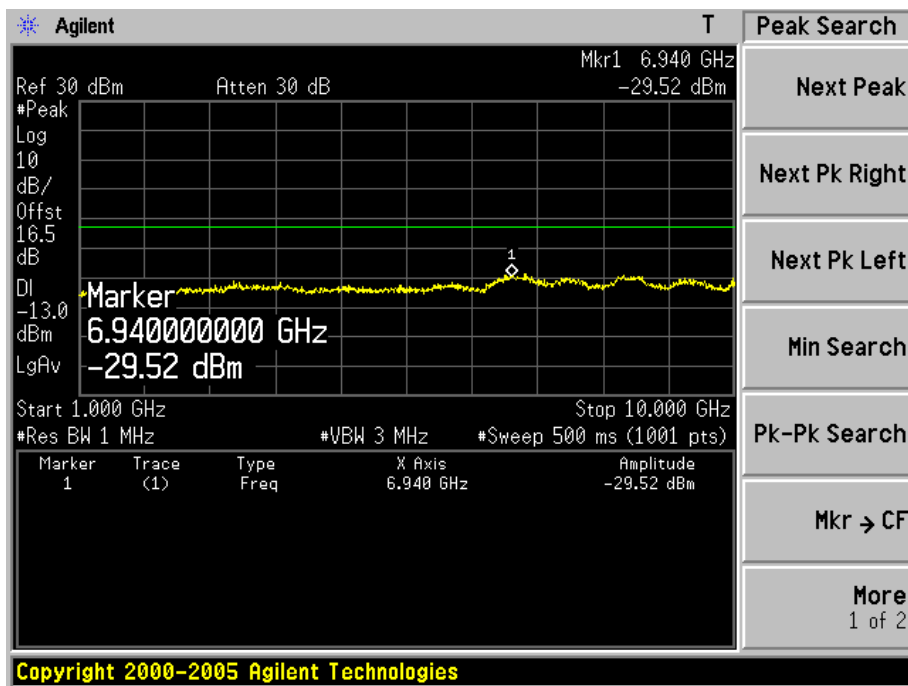
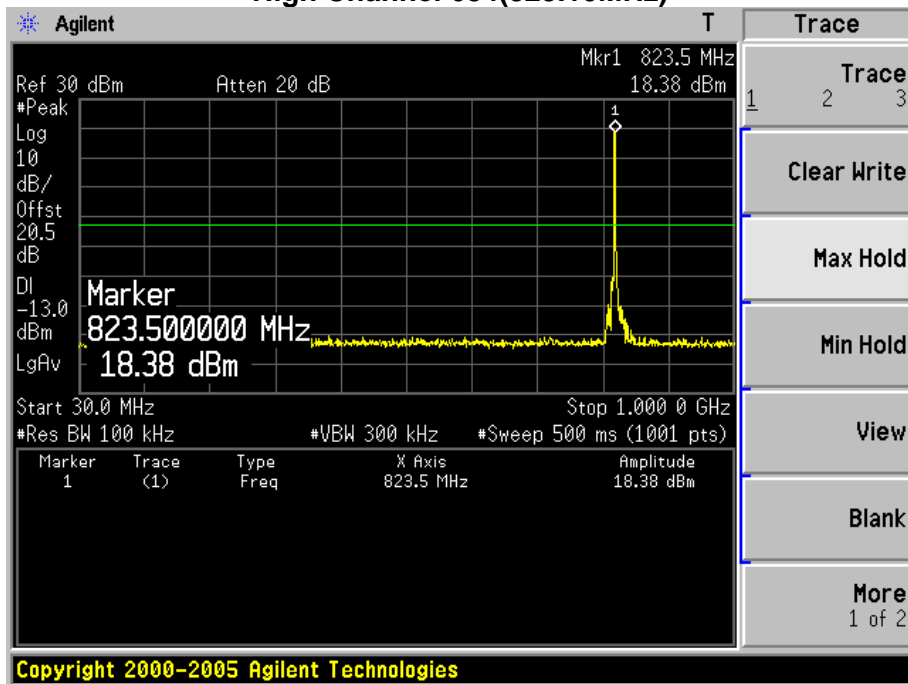

Product	Wireless Module		
Test Item	Radiated Spurious Emission		
Test Mode	Mode 1: CDMA 2000 1X BC0 Link		
Date of Test	2015/01/16	Test Site	AC-5

Frequency (MHz)	SA Reading (dBm)	Ant.Pol. (H/V)	SG Reading (dBm)	Cable Loss (dB)	Gain (dBi)	EIRP (dBm)	Limit (dBm)	Margin (dB)
Low Channel 1013 (824.70MHz)								
1649.40	-63.20	V	-65.78	2.50	9.78	-58.50	-13.00	-45.50
2474.10	-63.60	V	-62.71	3.12	10.49	-55.34	-13.00	-42.34
1649.40	-59.05	H	-61.74	2.50	9.78	-54.46	-13.00	-41.46
2474.10	-63.84	H	-62.78	3.12	10.49	-55.41	-13.00	-42.41
Middle Channel 384 (836.52MHz)								
1672.64	-60.98	V	-63.64	2.51	9.94	-56.21	-13.00	-43.21
2508.96	-59.87	V	-59.17	3.18	10.61	-51.74	-13.00	-38.74
1672.64	-60.93	H	-63.32	2.51	9.94	-55.89	-13.00	-42.89
2508.96	-63.09	H	-62.07	3.18	10.61	-54.64	-13.00	-41.64
High Channel 777 (848.31MHz)								
1696.62	-60.56	V	-63.35	2.53	10.10	-55.78	-13.00	-42.78
2544.93	-63.76	V	-62.23	3.15	10.67	-54.71	-13.00	-41.71
1696.62	-59.53	H	-61.58	2.53	10.10	-54.01	-13.00	-41.01
2544.93	-64.34	H	-62.55	3.15	10.67	-55.03	-13.00	-42.03

Product	Wireless Module		
Test Item	Radiated Spurious Emission		
Test Mode	Mode 2: CDMA 2000 1X BC1 Link		
Date of Test	2015/01/16	Test Site	AC-5

Frequency (MHz)	SA Reading (dBm)	Ant.Pol. (H/V)	SG Reading (dBm)	Cable Loss (dB)	Gain (dBi)	EIRP (dBm)	Limit (dBm)	Margin (dB)
Low Channel 25 (1851.25MHz)								
3702.50	-62.47	V	-45.23	3.83	12.69	-50.28	-13.00	-23.37
5553.75	-64.41	V	-52.12	4.82	13.14	-47.77	-13.00	-30.80
3702.50	-63.98	H	-49.74	3.83	12.69	-51.82	-13.00	-27.88
5553.75	-65.42	H	-51.71	4.82	13.14	-49.23	-13.00	-30.39
Middle Channel 600 (1880MHz)								
3760.00	-63.98	V	-49.94	3.73	12.72	-51.38	-13.00	-27.95
5640.00	-66.01	V	-49.55	4.92	13.13	-49.33	-13.00	-28.34
3760.00	-64.04	H	-50.96	3.73	12.72	-51.37	-13.00	-28.97
5640.00	-65.94	H	-55.59	4.92	13.13	-49.55	-13.00	-34.38
High Channel 1175 (1908.75MHz)								
3817.50	-64.27	V	-42.08	3.98	12.73	-52.79	-13.00	-20.33
5726.25	-64.99	V	-47.76	4.86	13.11	-49.42	-13.00	-26.51
3817.50	-64.59	H	-45.53	3.98	12.73	-52.72	-13.00	-23.78
5726.25	-64.17	H	-50.71	4.86	13.11	-47.99	-13.00	-29.46

Product	Wireless Module		
Test Item	Radiated Spurious Emission		
Test Mode	Mode 3: CDMA 2000 1X BC10 Link		
Date of Test	2015/02/09	Test Site	AC-5

Frequency (MHz)	SA Reading (dBm)	Ant.Pol. (H/V)	SG Reading (dBm)	Cable Loss (dB)	Gain (dBi)	EIRP (dBm)	Limit (dBm)	Margin (dB)
Low Channel 476 (817.90MHz)								
1635.80	-65.44	V	-60.42	2.41	9.68	-53.15	-13.00	-40.15
2453.70	-66.24	V	-56.76	3.05	10.41	-49.40	-13.00	-36.40
1635.80	-64.56	H	-59.62	2.41	9.68	-52.35	-13.00	-39.35
2453.70	-66.82	H	-57.96	3.05	10.41	-50.60	-13.00	-37.60
Middle Channel 580 (820.50MHz)								
1641.00	-64.90	V	-60.01	2.42	9.72	-52.71	-13.00	-39.71
2641.50	-66.56	V	-58.17	3.09	10.85	-50.41	-13.00	-37.41
1641.00	-64.49	H	-59.53	2.42	9.72	-52.23	-13.00	-39.23
2641.50	-65.77	H	-57.70	3.09	10.85	-49.94	-13.00	-36.94
High Channel 684 (823.10MHz)								
1646.20	-65.06	V	-59.94	2.44	9.75	-52.63	-13.00	-39.63
2469.30	-65.67	V	-56.13	3.10	10.47	-48.76	-13.00	-35.76
1646.20	-64.60	H	-59.33	2.44	9.75	-52.02	-13.00	-39.02
2469.30	-66.65	H	-57.51	3.10	10.47	-50.14	-13.00	-37.14

Product	Wireless Module		
Test Item	Radiated Spurious Emission		
Test Mode	Mode 4: CDMA 2000 1XEVD0 Rel-0 BC0 Link		
Date of Test	2015/01/16	Test Site	AC-5

Frequency (MHz)	SA Reading (dBm)	Ant.Pol. (H/V)	SG Reading (dBm)	Cable Loss (dB)	Gain (dBi)	EIRP (dBm)	Limit (dBm)	Margin (dB)
Low Channel 1013 (824.70MHz)								
1649.40	-62.07	V	-57.52	2.50	9.78	-50.24	-13.00	-37.24
2474.10	-65.12	V	-56.23	3.12	10.49	-48.86	-13.00	-35.86
1649.40	-61.24	H	-57.29	2.50	9.78	-50.01	-13.00	-37.01
2474.10	-64.41	H	-55.62	3.12	10.49	-48.25	-13.00	-35.25
Middle Channel 384 (836.52MHz)								
1672.64	-59.03	V	-61.70	2.51	9.94	-54.27	-13.00	-41.27
2508.96	-60.57	V	-59.87	3.18	10.61	-52.44	-13.00	-39.44
1672.64	-58.90	H	-61.32	2.51	9.94	-53.89	-13.00	-40.89
2508.96	-62.75	H	-61.73	3.18	10.61	-54.30	-13.00	-41.30
High Channel 777 (848.31MHz)								
1696.62	-60.93	V	-63.71	2.53	10.10	-56.14	-13.00	-43.14
2544.93	-62.62	V	-61.09	3.15	10.67	-53.57	-13.00	-40.57
1696.62	-58.35	H	-60.40	2.53	10.10	-52.83	-13.00	-39.83
2544.93	-63.57	H	-61.78	3.15	10.67	-54.26	-13.00	-41.26

Product	Wireless Module		
Test Item	Radiated Spurious Emission		
Test Mode	Mode 5: CDMA 2000 1XEVD0 Rel-0 BC1 Link		
Date of Test	2015/01/16	Test Site	AC-5

Frequency (MHz)	SA Reading (dBm)	Ant.Pol. (H/V)	SG Reading (dBm)	Cable Loss (dB)	Gain (dBi)	EIRP (dBm)	Limit (dBm)	Margin (dB)
Low Channel 25 (1851.25MHz)								
3702.50	-63.08	V	-60.11	3.83	12.69	-51.25	-13.00	-38.25
5553.75	-66.22	V	-58.28	4.82	13.14	-49.96	-13.00	-36.96
3702.50	-62.34	H	-59.97	3.83	12.69	-51.11	-13.00	-38.11
5553.75	-65.51	H	-57.67	4.82	13.14	-49.35	-13.00	-36.35
Middle Channel 600 (1880MHz)								
3760.00	-63.96	V	-61.04	3.73	12.72	-52.05	-13.00	-39.05
5640.00	-64.50	V	-56.62	4.92	13.13	-48.41	-13.00	-35.41
3760.00	-62.80	H	-59.82	3.73	12.72	-50.83	-13.00	-37.83
5640.00	-65.40	H	-57.07	4.92	13.13	-48.86	-13.00	-35.86
High Channel 1175 (1908.75MHz)								
3817.50	-62.77	V	-61.05	3.98	12.73	-52.30	-13.00	-39.30
5726.25	-65.23	V	-59.23	4.86	13.11	-50.98	-13.00	-37.98
3817.50	-63.32	H	-60.40	3.98	12.73	-51.65	-13.00	-38.65
5726.25	-66.34	H	-58.00	4.86	13.11	-49.75	-13.00	-36.75

Product	Wireless Module		
Test Item	Radiated Spurious Emission		
Test Mode	Mode 6: CDMA 2000 1XEVD0 Rel-0 BC10 Link		
Date of Test	2015/02/09	Test Site	AC-5

Frequency (MHz)	SA Reading (dBm)	Ant.Pol. (H/V)	SG Reading (dBm)	Cable Loss (dB)	Gain (dBi)	EIRP (dBm)	Limit (dBm)	Margin (dB)
Low Channel 476 (817.90MHz)								
1649.40	-65.02	V	-60.02	2.50	9.78	-52.74	-13.00	-39.74
2474.10	-65.93	V	-56.47	3.12	10.49	-49.10	-13.00	-36.10
1649.40	-64.44	H	-59.51	2.50	9.78	-52.23	-13.00	-39.23
2474.10	-66.35	H	-57.51	3.12	10.49	-50.14	-13.00	-37.14
Middle Channel 580 (820.50MHz)								
1672.64	-64.98	V	-60.22	2.51	9.94	-52.79	-13.00	-39.79
2508.96	-66.39	V	-57.67	3.18	10.61	-50.24	-13.00	-37.24
1672.64	-64.74	H	-59.91	2.51	9.94	-52.48	-13.00	-39.48
2508.96	-66.34	H	-57.94	3.18	10.61	-50.51	-13.00	-37.51
High Channel 684 (823.10MHz)								
1696.62	-65.01	V	-60.15	2.53	10.10	-52.58	-13.00	-39.58
2544.93	-65.99	V	-56.60	3.15	10.67	-49.08	-13.00	-36.08
1696.62	-65.10	H	-60.09	2.53	10.10	-52.52	-13.00	-39.52
2544.93	-66.35	H	-57.36	3.15	10.67	-49.84	-13.00	-36.84

Product	Wireless Module		
Test Item	Radiated Spurious Emission		
Test Mode	Mode 7: CDMA 2000 1XEVD0 Rel-A BC0 Link		
Date of Test	2015/01/16	Test Site	AC-5

Frequency (MHz)	SA Reading (dBm)	Ant.Pol. (H/V)	SG Reading (dBm)	Cable Loss (dB)	Gain (dBi)	EIRP (dBm)	Limit (dBm)	Margin (dB)
Low Channel 1013 (824.70MHz)								
1649.40	-60.05	V	-62.65	2.50	9.78	-55.37	-13.00	-42.37
2474.10	-64.10	V	-63.22	3.12	10.49	-55.85	-13.00	-42.85
1649.40	-58.59	H	-61.16	2.50	9.78	-53.88	-13.00	-40.88
2474.10	-64.00	H	-62.94	3.12	10.49	-55.57	-13.00	-42.57
Middle Channel 384 (836.52MHz)								
1672.64	-60.57	V	-63.24	2.51	9.94	-55.81	-13.00	-42.81
2508.96	-61.93	V	-61.30	3.18	10.61	-53.87	-13.00	-40.87
1672.64	-57.64	H	-60.06	2.51	9.94	-52.63	-13.00	-39.63
2508.96	-63.19	H	-62.16	3.18	10.61	-54.73	-13.00	-41.73
High Channel 777 (848.31MHz)								
1696.62	-61.84	V	-64.63	2.53	10.10	-57.06	-13.00	-44.06
2544.93	-63.66	V	-62.13	3.15	10.67	-54.61	-13.00	-41.61
1696.62	-59.51	H	-61.57	2.53	10.10	-54.00	-13.00	-41.00
2544.93	-63.07	H	-61.28	3.15	10.67	-53.76	-13.00	-40.76

Product	Wireless Module		
Test Item	Radiated Spurious Emission		
Test Mode	Mode 8: CDMA 2000 1XEVD0 Rel-A BC1 Link		
Date of Test	2015/01/16	Test Site	AC-5

Frequency (MHz)	SA Reading (dBm)	Ant.Pol. (H/V)	SG Reading (dBm)	Cable Loss (dB)	Gain (dBi)	EIRP (dBm)	Limit (dBm)	Margin (dB)
Low Channel 25 (1851.25MHz)								
3702.50	-63.68	V	-60.64	3.83	12.69	-51.78	-13.00	-38.78
5553.75	-64.86	V	-57.39	4.82	13.14	-49.07	-13.00	-36.07
3702.50	-64.18	H	-60.54	3.83	12.69	-51.68	-13.00	-38.68
5553.75	-65.72	H	-58.05	4.82	13.14	-49.73	-13.00	-36.73
Middle Channel 600 (1880MHz)								
3760.00	-64.17	V	-61.10	3.73	12.72	-52.11	-13.00	-39.11
5640.00	-65.01	V	-57.65	4.92	13.13	-49.44	-13.00	-36.44
3760.00	-63.29	H	-60.36	3.73	12.72	-51.37	-13.00	-38.37
5640.00	-65.02	H	-57.17	4.92	13.13	-48.96	-13.00	-35.96
High Channel 1175 (1908.75MHz)								
3817.50	-62.59	V	-59.15	3.98	12.73	-50.40	-13.00	-37.40
5726.25	-64.29	V	-56.73	4.86	13.11	-48.48	-13.00	-35.48
3817.50	-64.03	H	-60.61	3.98	12.73	-51.86	-13.00	-38.86
5726.25	-65.20	H	-56.95	4.86	13.11	-48.70	-13.00	-35.70

Product	Wireless Module		
Test Item	Radiated Spurious Emission		
Test Mode	Mode 9: CDMA 2000 1XEVD0 Rel-A BC10 Link		
Date of Test	2015/02/09	Test Site	AC-5

Frequency (MHz)	SA Reading (dBm)	Ant.Pol. (H/V)	SG Reading (dBm)	Cable Loss (dB)	Gain (dBi)	EIRP (dBm)	Limit (dBm)	Margin (dB)
Low Channel 476 (817.90MHz)								
1649.40	-63.97	V	-59.95	2.50	9.78	-52.67	-13.00	-39.67
2474.10	-65.47	V	-57.01	3.12	10.49	-49.64	-13.00	-36.64
1649.40	-64.30	H	-59.36	2.50	9.78	-52.08	-13.00	-39.08
2474.10	-63.60	H	-54.76	3.12	10.49	-47.39	-13.00	-34.39
Middle Channel 580 (820.50MHz)								
1672.64	-64.74	V	-59.97	2.51	9.94	-52.54	-13.00	-39.54
2508.96	-66.06	V	-57.34	3.18	10.61	-49.91	-13.00	-36.91
1672.64	-64.00	H	-59.16	2.51	9.94	-51.73	-13.00	-38.73
2508.96	-65.78	H	-57.37	3.18	10.61	-49.94	-13.00	-36.94
High Channel 684 (823.10MHz)								
1696.62	-64.35	V	-59.48	2.53	10.10	-51.91	-13.00	-38.91
2544.93	-66.09	V	-56.82	3.15	10.67	-49.30	-13.00	-36.30
1696.62	-64.12	H	-59.08	2.53	10.10	-51.51	-13.00	-38.51
2544.93	-66.01	H	-57.07	3.15	10.67	-49.55	-13.00	-36.55

8. Frequency Stability Under Temperature & Voltage Variations

8.1. Test Equipment

Frequency Stability Under Temperature & Voltage Variations / TR-7

Instrument	Manufacturer	Type No.	Serial No	Cali. Due Date
PSA Series Spectrum Analyzer	Agilent	E4440A	MY49420184	2015.03.28
Radio Communication Tester	R&S	CMU 200	117088	2015.03.28
Dual Directional Coupler	Agilent	778D	20160	2015.03.28
10dB Coaxial Coupler	Agilent	87300C	MY44300299	2015.03.28
DC Power Supply	IDRC	CD-035-020PR	977272	2015.03.28
Temperature & Humidity Chamber	Gaoyu	TH-1P-B	WIT-05121302	2016.01.07
Temperature/Humidity Meter	Zhicheng	ZC1-2	AC6-TH	2016.01.07

8.2. Test Setup

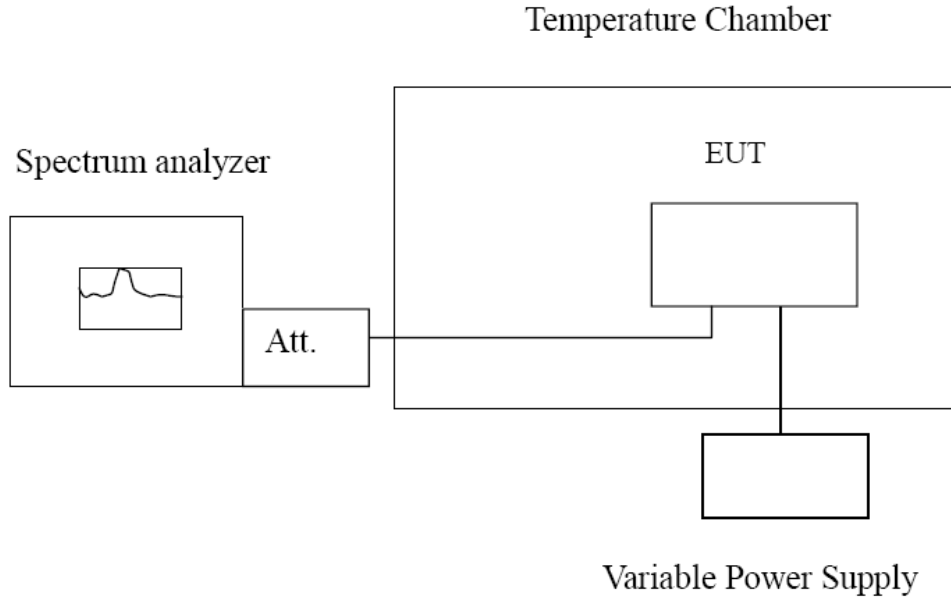

8.3. Test Procedure

Frequency Stability Under Temperature Variations:

The equipment under test was connected to an external AC or DC power supply and input rated voltage. RF output was connected to a frequency counter or spectrum analyzer via feed through attenuators. The EUT was placed inside the temperature chamber. Set the spectrum analyzer RBW low enough to obtain the desired frequency resolution and measure EUT 20°C operating frequency as reference frequency. Turn EUT off and set the chamber temperature to -30°C. After the temperature stabilized for approximately 30 minutes recorded the frequency. Repeat step measure with 10°C increased per stage until the highest temperature of +50°C reached.

Frequency Stability Under Voltage Variations:

Set chamber temperature to 20°C. Use a variable AC power supply / DC power source to power the EUT and set the voltage to rated voltage. Set the spectrum analyzer RBW low enough to obtain the desired frequency resolution and recorded the frequency.

Reduce the input voltage to specify extreme voltage variation ($\pm 15\%$) and endpoint, record the maximum frequency change.

8.4. Uncertainty

The measurement uncertainty is defined as ± 10 Hz.

8.5. Test Result

Product	Wireless Module		
Test Item	Frequency Stability Under Temperature & Voltage Variations		
Test Mode	Mode 1: CDMA 2000 1X BC0 Link		
Date of Test	2015/01/16	Test Site	TR-7

Frequency Stability under Temperature

Temperature Interval (°C)	Test Frequency (MHz)	Deviation (Hz)	Limit (Hz)
-30	836.52	43	± 2091.3
-20	836.52	35	± 2091.3
-10	836.52	23	± 2091.3
0	836.52	-32	± 2091.3
10	836.52	-24	± 2091.3
20	836.52	16	± 2091.3
30	836.52	16	± 2091.3
40	836.52	53	± 2091.3
50	836.52	-62	± 2091.3

Frequency Stability under Voltage

DC Voltage (V)	Test Frequency (MHz)	Deviation (Hz)	Limit (Hz)
4.200	836.52	20	± 2091.3
3.700	836.52	22	± 2091.3
3.400	836.52	-35	± 2091.3

Product	Wireless Module		
Test Item	Frequency Stability Under Temperature & Voltage Variations		
Test Mode	Mode 2: CDMA 2000 1X BC1 Link		
Date of Test	2015/01/16	Test Site	TR-7

Frequency Stability under Temperature

Temperature Interval (°C)	Test Frequency (MHz)	Deviation (Hz)	Limit (Hz)
-30	1880	43	± 4700
-20	1880	30	± 4700
-10	1880	-28	± 4700
0	1880	29	± 4700
10	1880	-16	± 4700
20	1880	25	± 4700
30	1880	-35	± 4700
40	1880	-40	± 4700
50	1880	-56	± 4700

Frequency Stability under Voltage

DC Voltage (V)	Test Frequency (MHz)	Deviation (Hz)	Limit (Hz)
4.200	1880	16	± 4700
3.700	1880	25	± 4700
3.400	1880	43	± 4700

Product	Wireless Module		
Test Item	Frequency Stability Under Temperature & Voltage Variations		
Test Mode	Mode 3: CDMA 2000 1X BC10 Link		
Date of Test	2015/02/09	Test Site	TR-7

Frequency Stability under Temperature

Temperature Interval (°C)	Test Frequency (MHz)	Deviation (Hz)	Limit (Hz)
-30	820.50	48	± 2051.3
-20	820.50	33	± 2051.3
-10	820.50	29	± 2051.3
0	820.50	66	± 2051.3
10	820.50	-30	± 2051.3
20	820.50	43	± 2051.3
30	820.50	29	± 2051.3
40	820.50	-56	± 2051.3
50	820.50	-30	± 2051.3

Frequency Stability under Voltage

DC Voltage (V)	Test Frequency (MHz)	Deviation (Hz)	Limit (Hz)
4.200	820.50	16	± 2051.3
3.700	820.50	-33	± 2051.3
3.400	820.50	-46	± 2051.3

Product	Wireless Module		
Test Item	Frequency Stability Under Temperature & Voltage Variations		
Test Mode	Mode 4: CDMA 2000 1XEVD0 Rel-0 BC0 Link		
Date of Test	2015/01/16	Test Site	TR-7

Frequency Stability under Temperature

Temperature Interval (°C)	Test Frequency (MHz)	Deviation (Hz)	Limit (Hz)
-30	836.52	38	± 2091.3
-20	836.52	-12	± 2091.3
-10	836.52	30	± 2091.3
0	836.52	27	± 2091.3
10	836.52	25	± 2091.3
20	836.52	55	± 2091.3
30	836.52	-60	± 2091.3
40	836.52	38	± 2091.3
50	836.52	-43	± 2091.3

Frequency Stability under Voltage

DC Voltage (V)	Test Frequency (MHz)	Deviation (Hz)	Limit (Hz)
4.200	836.52	-22	± 2091.3
3.700	836.52	16	± 2091.3
3.400	836.52	38	± 2091.3

Product	Wireless Module		
Test Item	Frequency Stability Under Temperature & Voltage Variations		
Test Mode	Mode 5: CDMA 2000 1XEVD0 Rel-0 BC1 Link		
Date of Test	2015/01/16	Test Site	TR-7

Frequency Stability under Temperature

Temperature Interval (°C)	Test Frequency (MHz)	Deviation (Hz)	Limit (Hz)
-30	1880	13	± 4700
-20	1880	25	± 4700
-10	1880	17	± 4700
0	1880	42	± 4700
10	1880	-32	± 4700
20	1880	-20	± 4700
30	1880	-56	± 4700
40	1880	-35	± 4700
50	1880	20	± 4700

Frequency Stability under Voltage

DC Voltage (V)	Test Frequency (MHz)	Deviation (Hz)	Limit (Hz)
4.200	1880	30	± 4700
3.700	1880	17	± 4700
3.400	1880	14	± 4700

Product	Wireless Module		
Test Item	Frequency Stability Under Temperature & Voltage Variations		
Test Mode	Mode 6: CDMA 2000 1XEVD0 Rel-0 BC10 Link		
Date of Test	2015/02/09	Test Site	TR-7

Frequency Stability under Temperature

Temperature Interval (°C)	Test Frequency (MHz)	Deviation (Hz)	Limit (Hz)
-30	820.50	43	± 2051.3
-20	820.50	45	± 2051.3
-10	820.50	-65	± 2051.3
0	820.50	-44	± 2051.3
10	820.50	-28	± 2051.3
20	820.50	49	± 2051.3
30	820.50	40	± 2051.3
40	820.50	-77	± 2051.3
50	820.50	-29	± 2051.3

Frequency Stability under Voltage

DC Voltage (V)	Test Frequency (MHz)	Deviation (Hz)	Limit (Hz)
4.200	820.50	-36	± 2051.3
3.700	820.50	28	± 2051.3
3.400	820.50	41	± 2051.3

Product	Wireless Module		
Test Item	Frequency Stability Under Temperature & Voltage Variations		
Test Mode	Mode 5: CDMA 2000 1XEVD0 Rel-A BC0 Link		
Date of Test	2015/01/16	Test Site	TR-7

Frequency Stability under Temperature

Temperature Interval (°C)	Test Frequency (MHz)	Deviation (Hz)	Limit (Hz)
-30	836.52	-35	± 2091.3
-20	836.52	24	± 2091.3
-10	836.52	10	± 2091.3
0	836.52	-50	± 2091.3
10	836.52	25	± 2091.3
20	836.52	-27	± 2091.3
30	836.52	-20	± 2091.3
40	836.52	-15	± 2091.3
50	836.52	-66	± 2091.3

Frequency Stability under Voltage

DC Voltage (V)	Test Frequency (MHz)	Deviation (Hz)	Limit (Hz)
4.200	836.52	57	± 2091.3
3.700	836.52	-53	± 2091.3
3.400	836.52	-42	± 2091.3

Product	Wireless Module		
Test Item	Frequency Stability Under Temperature & Voltage Variations		
Test Mode	Mode 6: CDMA 2000 1XEVDO Rel-A BC1 Link		
Date of Test	2015/01/16	Test Site	TR-7

Frequency Stability under Temperature

Temperature Interval (°C)	Test Frequency (MHz)	Deviation (Hz)	Limit (Hz)
-30	1880	35	± 4700
-20	1880	-22	± 4700
-10	1880	32	± 4700
0	1880	25	± 4700
10	1880	37	± 4700
20	1880	-42	± 4700
30	1880	29	± 4700
40	1880	-26	± 4700
50	1880	-22	± 4700

Frequency Stability under Voltage

DC Voltage (V)	Test Frequency (MHz)	Deviation (Hz)	Limit (Hz)
4.200	1880	-28	± 4700
3.700	1880	-25	± 4700
3.400	1880	-45	± 4700

Product	Wireless Module		
Test Item	Frequency Stability Under Temperature & Voltage Variations		
Test Mode	Mode 9: CDMA 2000 1XEVD0 Rel-A BC10 Link		
Date of Test	2015/02/09	Test Site	TR-7

Frequency Stability under Temperature

Temperature Interval (°C)	Test Frequency (MHz)	Deviation (Hz)	Limit (Hz)
-30	820.50	25	± 2051.3
-20	820.50	31	± 2051.3
-10	820.50	-41	± 2051.3
0	820.50	-39	± 2051.3
10	820.50	26	± 2051.3
20	820.50	-64	± 2051.3
30	820.50	48	± 2051.3
40	820.50	51	± 2051.3
50	820.50	-45	± 2051.3

Frequency Stability under Voltage

DC Voltage (V)	Test Frequency (MHz)	Deviation (Hz)	Limit (Hz)
4.200	820.50	-28	± 2051.3
3.700	820.50	73	± 2051.3
3.400	820.50	65	± 2051.3

_____ The End _____