



SAR Evaluation Report

in accordance with the requirements of
FCC Report and Order: ET Docket 93-62, and OET Bulletin 65 Supplement C

for

800/1900 MHz Dual Band PCMCIA Card With Laptop PC (Gateway)

MODEL: AirCard 555

FCC ID: N7NACRD555

Date: September 7, 2002

REPORT NO: 02U1473-3

Prepared for

**SIERRA WIRELESS INC
13811 WIRELESS WAY
RICHMOND, BRITISH COLUMBIA V6V 3A4
CANADA**

Prepared by

**COMPLIANCE CERTIFICATION SERVICES
561F MONTEREY ROAD,
MORGAN HILL, CA 95037 USA
TEL: (408) 463-0885**



CERTIFICATE OF COMPLIANCE (SAR EVALUATION)

Dates of Tests: September 6 & 7, 2000

Report No: 02U1473-3

APPLICANT:	SIERRA WIRELESS INC 13811 WIRELESS WAY, RICHMOND, BRITISH COLUMBIA V6V 3A4 CANADA
MODEL:	AirCard 555
FCC ID:	N7NACRD555
DEVICE CATEGORY:	PORTABLE DEVICES
EXPOSURE CATEGORY:	GENERAL POLULATION/UNCONTROLLED EXPOSURE

Test Sample is a: PRODUCTION UNIT

Standard: CDMA

Operating Mode: Maximum Continuous Output

Tx Frequency: 824 – 849 MHz
1850 – 1910 MHz

Rx Frequency: 869 – 894 MHz
1930 – 1990 MHz

Max. Output Power (Conducted): 23.12 dBm (824.04 MHz)
23.05 dBm (1850.0 MHz)

Max. SAR (1g): 1.11 mW/g (848.97 MHz)
1.22 mW/g (1880 MHz)

Application Type: Certification

FCC Rule Part(s): § 22(H) / 24(E)



This wireless portable device has been shown to be capable of compliance for localized specific absorption rate (SAR) for uncontrolled environment/general population exposure limits specified in ANSI/IEEE Std. C95.1-1992 and had been tested in accordance with the measurement procedures specified in FCC OET 65 Supplement C (released on 6/29/2001 see Test Report).

I attest to the accuracy of data. All measurements reported herein were performed by me or were made under my supervision and are correct to the best of my knowledge and belief. I assume full responsibility for the completeness of these measurements and vouch for the qualifications of all persons taking them.

Steve Cheng
EMC Engineering Manager

TABLE OF CONTENT

1.	EUT DESCRIPTION	4
2.	REQUIREMENTS FOR COMPLIANCE TESTING DEFINED BY THE FCC.....	5
3.	DOSIMETRIC ASSESSMENT SYSTEM	5
3.1.	MEASUREMENT SYSTEM DIAGRAM.....	6
3.2.	SYSTEM COMPONENTS.....	7
4.	EVALUATION PROCEDURE.....	9
5.	MEASUREMENT UNCERTAINTY	12
6.	EXPOSURE LIMIT	13
7.	MEASUREMENT RESULTS	14
7.1.	SYSTEM VALIDATION.....	14
7.2.	TEST LIQUID CONFIRMATION	14
7.3.	EUT TUNE-UP PROCEDURE	16
8.	EUT SETUP PHOTOS.....	17
8.1.	SAR MEASUREMENT RESULT.....	17
8.1.1.	Cell 835 MHz.....	19
8.1.2.	PCS 1900 MHz.....	20
9.	EUT PHOTOS.....	21
10.	EQUIPMENTS LIST & CALIBRATION STATUS	23
11.	REFERENCES	24
12.	ATTACHMENT	25

1. EUT DESCRIPTION

APPLICANT:	SIERRA WIRELESS INC 13811 WIRELESS WAY, RICHMOND BRITISH COLUMBIA V6V 3A4 CANADA
MODEL:	AirCard 555
FCC ID:	N7NACRD555
DEVICE CATEGORY:	PORTABLE DEVICES
EXPOSURE CATEGORY:	GENERAL POLULATION/UNCONTROLLED EXPOSURE

Test Sample is a:	PRODUCTION UNIT
Standard:	CDMA
Operating Mode:	Maximum Continuous Output
Tx Frequency:	824 – 849 MHz 1850 – 1910 MHz
Rx Frequency:	869 – 894 MHz 1930 – 1990 MHz
Max. Output Power (Conducted):	23.12 dBm (824.04 MHz) 23.05 dBm (1850.0 MHz)
Max. SAR (1g):	1.11 mW/g (848.97 MHz) 1.22 mW/g (1880 MHz)mW/g
Application Type:	Certification
FCC Rule Part(s):	§ 22(H) / 24(E)
Antenna Type:	Monopole
Antenna dimensions	Approx.: Length = 145 mm; Diameter = 1.2 mm



- ¹ Specific Absorption Rate (SAR) is a measure of the rate of energy absorption due to exposure to an RF transmitting source (wireless portable device).
- ² IEEE/ANSI Std. C95.1-1992 limits are used to determine compliance with FCC ET Docket 93-62.

2. REQUIREMENTS FOR COMPLIANCE TESTING DEFINED BY THE FCC

The US Federal Communications Commission has released the report and order "Guidelines for Evaluating the Environmental Effects of RF Radiation", ET Docket No. 93-62 in August 1996 [1]. The order requires routine SAR evaluation prior to equipment authorization of portable transmitter devices, including portable telephones. For consumer products, the applicable limit is 1.6 mW/g for an uncontrolled environment and 8.0 mW/g for an occupational/controlled environment as recommended by the ANSI/IEEE standard C95.1-1992 [6]. According to the Supplement C of OET Bulletin 65 "Evaluating Compliance with FCC Guide-lines for Human Exposure to Radio frequency Electromagnetic Fields", released on Jun 29, 2001 by the FCC, the device should be evaluated at maximum output power (radiated from the antenna) under "worst-case" conditions for normal or intended use, incorporating normal antenna operating positions, device peak performance frequencies and positions for maximum RF energy coupling.

3. DOSIMETRIC ASSESSMENT SYSTEM

These measurements were performed with the automated near-field scanning system DASY3 from Schmid & Partner Engineering AG (SPEAG). The system is based on a high precision robot (working range greater than 0.9 m) which positions the probes with a positional repeatability of better than ± 0.02 mm. Special E- and H-field probes have been developed for measurements close to material discontinuity, the sensors of which are directly loaded with a Schottky diode and connected via highly resistive lines to the data acquisition unit. The SAR measurements were conducted with the dosimetric probe ET3DV6 SN: 1577 (manufactured by SPEAG), designed in the classical triangular configuration [3] and optimized for dosimetric evaluation. The probe has been calibrated according to the procedure described in [7] with accuracy of better than $\pm 10\%$. The spherical isotropy was evaluated with the procedure described in [8] and found to be better than ± 0.25 dB. The phantom used was the SAM Twin Phantom as described in FCC supplement C, IEEE P1528 and EN50361.

The Tissue simulation liquid used for each test is in according with the FCC OET65 supplement C as listed below.

Ingredients (% by weight)	Frequency (MHz)									
	450		835		915		1900		2450	
Tissue Type	Head	Body	Head	Body	Head	Body	Head	Body	Head	Body
Water	38.56	51.16	41.45	52.4	41.05	56.0	54.9	40.4	62.7	73.2
Salt (NaCl)	3.95	1.49	1.45	1.4	1.35	0.76	0.18	0.5	0.5	0.04
Sugar	56.32	46.78	56.0	45.0	56.5	41.76	0.0	58.0	0.0	0.0
HEC	0.98	0.52	1.0	1.0	1.0	1.21	0.0	1.0	0.0	0.0
Bactericide	0.19	0.05	0.1	0.1	0.1	0.27	0.0	0.1	0.0	0.0
Triton X-100	0.0	0.0	0.0	0.0	0.0	0.0	0.0	0.0	36.8	0.0
DGBE	0.0	0.0	0.0	0.0	0.0	0.0	44.92	0.0	0.0	26.7
Dielectric Constant	43.42	58.0	42.54	56.1	42.0	56.8	39.9	54.0	39.8	52.5
Conductivity (S/m)	0.85	0.83	0.91	0.95	1.0	1.07	1.42	1.45	1.88	1.78

3.1. MEASUREMENT SYSTEM DIAGRAM

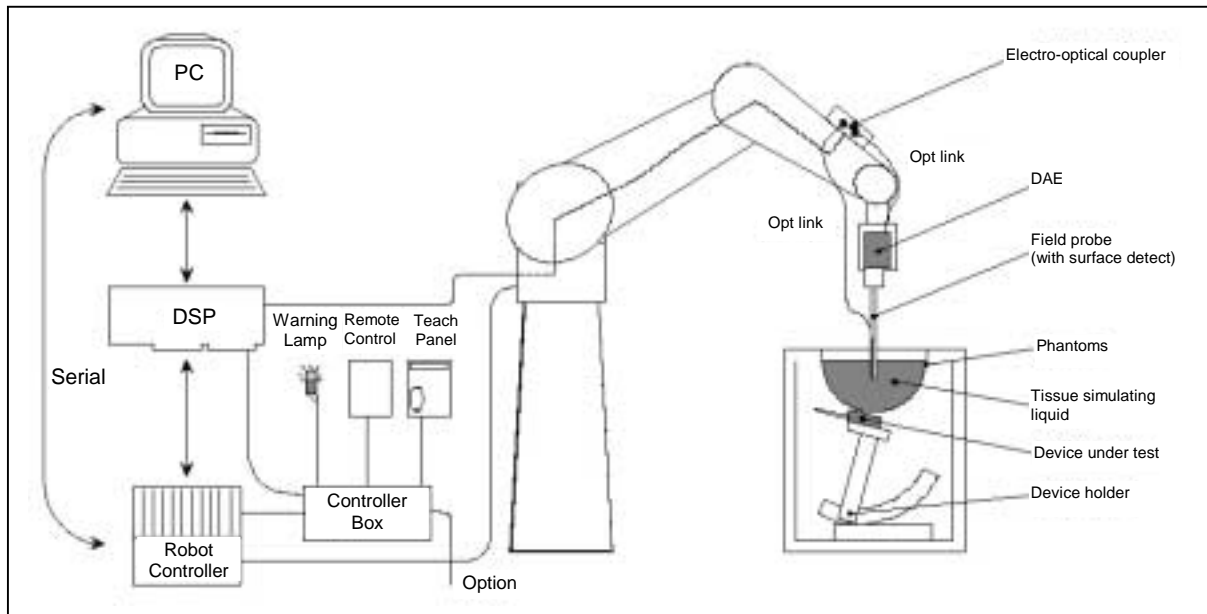

The DASY3 system for performing compliance tests consist of the following items:

1. A standard high precision 6-axis robot (Stäubli RX family) with controller and software.
2. An arm extension for accommodating the data acquisition electronics (DAE).
3. A dosimetric probe, i.e., an isotropic E-field probe optimized and calibrated for usage in tissue simulating liquid. The probe is equipped with an optical surface detector system.
4. A data acquisition electronic (DAE), which performs the signal amplification, signal multiplexing, AD-conversion, offset measurements, mechanical surface detection, collision detection, etc. The unit is battery powered with standard or rechargeable batteries. The signal is optically transmitted to the EOC.
5. A unit to operate the optical surface detector, which is connected to the EOC.
6. The Electro-optical coupler (EOC) performs the conversion from the optical into a digital electric signal of the DAE. The EOC is connected to the PC plug-in card.
7. The functions of the PC plug-in card based on a DSP is to perform the time critical task such as signal filtering, surveillance of the robot operation fast movement interrupts.
8. A computer operating Windows 95 or larger
9. DASY3 software
10. Remote control with teaches pendant and additional circuitry for robot safety such as warning lamps, etc.
11. The SAM phantom enabling testing left-hand and right-hand usage.
12. The device holder for handheld EUT.
13. Tissue simulating liquid mixed according to the given recipes (see Application Note).
14. System validation dipoles to validate the proper functioning of the system.

3.2. SYSTEM COMPONENTS

ET3DV5 Probe Specification

Construction Symmetrical design with triangular core
Built-in optical fiber for surface detection System
Built-in shielding against static charges
Calibration In air from 10 MHz to 2.5 GHz
In brain and muscle simulating tissue at
Frequencies of 450 MHz, 900 MHz and
1.8 GHz (accuracy $\pm 8\%$)
Frequency 10 MHz to > 6 GHz; Linearity: ± 0.2 dB
(30 MHz to 3 GHz)
Directivity ± 0.2 dB in brain tissue (rotation around probe axis)
 ± 0.4 dB in brain tissue (rotation normal probe axis)
Dynamic 5 mW/g to > 100 mW/g;
Range Linearity: ± 0.2 dB
Surface ± 0.2 mm repeatability in air and clear liquids
Detection over diffuse reflecting surfaces.
Dimensions Overall length: 330 mm
Tip length: 16 mm
Body diameter: 12 mm
Tip diameter: 6.8 mm
Distance from probe tip to dipole centers: 2.7 mm
Application General dosimetric up to 3 GHz
Compliance tests of mobile phones
Fast automatic scanning in arbitrary phantoms



Photograph of the probe



Inside view of
ET3DV6 E-field Probe

The SAR measurements were conducted with the dosimetric probe ET3DV6 designed in the classical triangular configuration and optimized for dosimetric evaluation. The probe is constructed using the thick film technique; with printed resistive lines on ceramic substrates. The probe is equipped with an optical multi-fiber line ending at the front of the probe tip. It is connected to the EOC box on the robot arm and provides an automatic detection of the phantom surface. Half of the fibers are connected to a pulsed infrared transmitter, the other half to a synchronized receiver. As the probe approaches the surface, the reflection from the surface produces a coupling from the transmitting to the receiving fibers. This reflection increases first during the approach, reaches maximum and then decreases. If the probe is flatly touching the surface, the coupling is zero. The distance of the coupling maximum to the surface is independent of the surface reflectivity and largely independent of the surface to probe angle. The DASY3 software reads the reflection during a software approach and looks for the maximum using a 2nd order fitting. The approach is stopped when reaching the maximum.

E-Field Probe Calibration Process

Each probe is calibrated according to a dosimetric assessment procedure described in [6] with accuracy better than +/- 10%. The spherical isotropy was evaluated with the procedure described in [7] and found to be better than +/-0.25dB. The sensitivity parameters (NormX, NormY, NormZ), the diode compression parameter (DCP) and the conversion factor (ConvF) of the probe are tested.

The free space E-field from amplified probe outputs is determined in a test chamber. This is performed in a TEM cell for frequencies below 1 GHz, and in a waveguide above 1 GHz for free space. For the free space calibration, the probe is placed in the volumetric center of the cavity and at the proper orientation with the field. The probe is then rotated 360 degrees.

E-field temperature correlation calibration is performed in a flat phantom filled with the appropriate simulated brain tissue. The measured free space E-field in the medium correlates to temperature rise in dielectric medium. For temperature correlation calibration a RF transparent thermistor-based temperature probe is used in conjunction with the E-field probe.

SAM Phantom

The SAM Phantom V4.0 is constructed of a fiberglass shell integrated in a wooden table. The shape of the shell is in compliance with the specification set in IEEE P1528 and CENELEC EN50361. The phantom enables the dosimetric evaluation of left and right hand phone usage as well as body mounted usage at the flat phantom region. A cover prevents the evaporation of the liquid. Reference markings on the Phantom allow the complete setup of all predefined phantom positions and measurement grids by manually teaching three points in the robot.

Shell Thickness: 2 ± 0.2 mm
Filling Volume: Approx. 25 liters
Dimensions (H x L x W): 810 x 1000 x 500 mm



SAM Phantom

Device Holder for Transmitters

In combination with the Generic Twin Phantom V3.0, the Mounting Device enables the rotation of the mounted transmitter in spherical coordinates whereby the rotation points is the ear opening. The devices can be easily, accurately, and repeatedly positioned according to the FCC and CENELEC specifications. The device holder can be locked at different phantom locations (left head, right head, flat phantom).

* Note: A simulating human hand is not used due to the complex anatomical and geometrical structure of the hand that may produced infinite number of configurations [10]. To produce the worst-case condition (the hand absorbs antenna output power), the hand is omitted during the tests.



Device Holder

4. EVALUATION PROCEDURE

Data Evaluation

The DASY3 software automatically executes the following procedures to calculate the field units from the microvolt readings at the probe connector. The parameters used in the evaluation are stored in the configuration modules of the software:

Probe parameters:	- Sensitivity	Norm _i , a _{i10} , a _{i11} , a _{i12}
	- Conversion factor	ConvF _i
	- Diode compression point	Dcp _i
Device parameters:	- Frequency	f
	- Crest factor	cf
Media parameters:	- Conductivity	σ
	- Density	ρ

These parameters must be set correctly in the software. They can either be found in the component documents or be imported into the software from the configuration files issued for the DASY3 components. In the direct measuring mode of the multi-meter option, the parameters of the actual system setup are used. In the scan visualization and export modes, the parameters stored in the corresponding document files are used.

The first step of the evaluation is a linearization of the filtered input signal to account for the compression characteristics of the detector diode. The compensation depends on the input signal, the diode type and the DC-transmission factor from the diode to the evaluation electronics. If the exciting field is pulsed, the crest factor of the signal must be known to correctly compensate for peak power. The formula for each channel can be given as:

$$V_i = U_i + U_i^2 \cdot \frac{cf}{dcp_i}$$

with	V_i	= Compensated signal of channel i	(i = x, y, z)
	U_i	= Input signal of channel i	(i = x, y, z)
	cf	= Crest factor of exciting field	(DASY parameter)
	dcp_i	= Diode compression point	(DASY parameter)

From the compensated input signals the primary field data for each channel can be evaluated:

E-field probes:
$$E_i = \sqrt{\frac{V_i}{Norm_i \cdot ConvF}}$$

H-field probes:
$$H_i = \sqrt{V_i} \cdot \frac{a_{i10} + a_{i11}f + a_{i12}f^2}{f}$$

with V_i = Compensated signal of channel i (i = x, y, z)

$Norm_i$ = Sensor sensitivity of channel i (i = x, y, z)

$\mu V/(V/m)^2$ for E0field Probes

$ConvF$ = Sensitivity enhancement in solution

a_{ij} = Sensor sensitivity factors for H-field probes

f = Carrier frequency (GHz)

E_i = Electric field strength of channel i in V/m

H_i = Magnetic field strength of channel i in A/m

The RSS value of the field components gives the total field strength (Hermitian magnitude):

$$E_{tot} = \sqrt{E_x^2 + E_y^2 + E_z^2}$$

The primary field data are used to calculate the derived field units.

$$SAR = E_{tot}^2 \cdot \frac{\sigma}{\rho \cdot 1000}$$

with SAR = local specific absorption rate in mW/g

E_{tot} = total field strength in V/m

σ = conductivity in [mho/m] or [siemens/m]

ρ = equivalent tissue density in g/cm³

Note that the density is normally set to 1 (or 1.06), to account for actual brain density rather than the density of the simulation liquid.

The power flow density is calculated assuming the excitation field as a free space field.

$$P_{pwe} = \frac{E_{tot}^2}{3770} \quad \text{or} \quad P_{pwe} = H_{tot}^2 \cdot 37.7$$

with P_{pwe} = Equivalent power density of a plane wave in mW/cm²

E_{tot} = total electric field strength in V/m

H_{tot} = total magnetic field strength in A/m

SAR Evaluation Procedure

The evaluation was performed with the following procedure:

Step 1: Measurement of the SAR value at a fixed location above the central position was used as a reference value for assessing the power drop.

Step 2: The SAR distribution at the exposed side of the body was measured at a distance of 3.9 mm from the inner surface of the shell. The area covered the entire dimension of the EUT and the horizontal grid spacing was 20 mm x 20 mm. Based on the data, the area of the maximum absorption was determined by spline interpolation.

Step 3: Around this point, a volume of 32 mm x 32 mm x 34 mm was assessed by measuring 5 x 5 x 7 points. On the basis of this data set, the spatial peak SAR value was evaluated under the following procedure:

1. The data at the surface were extrapolated, since the center of the dipoles is 2.7 mm away from the tip of the probe and the distance between the surface and the lowest measuring point is 1.2 mm. The extrapolation was based on a least square algorithm [11]. A polynomial of the fourth order was calculated through the points in z-axes. This polynomial was then used to evaluate the points between the surface and the probe tip.
2. The maximum interpolated value was searched with a straightforward algorithm. Around this maximum the SAR values averaged over the spatial volumes (1 g or 10 g) were computed by the 3D-Spline interpolation algorithm. The 3D-Spline is composed of three one-dimensional splines with the "Not a knot"-condition (in x, y and z-directions) [11], [12]. The volume was integrated with the trapezoidal-algorithm. One thousand points (10 x 10 x 10) were interpolated to calculate the average.
3. All neighboring volumes were evaluated until no neighboring volume with a higher average value was found.

Step 4: Re-measurement of the SAR value at the same location as in Step 1. If the value changed by more than 5%, the evaluation was repeated.

5. MEASUREMENT UNCERTAINTY

Uncertainty Budget per IEEE P1528

Error Description	Uncertainty value $\pm\%$	Probability distribution	divisor	c_i 1g	Standard unc. (1g) $\pm\%$	ν_i or ν_{eff}
Measurement System						
Probe calibration	± 4.8	normal	1	1	± 4.8	∞
Axial isotropy of the probe	± 4.7	rectangular	$\sqrt{3}$	$(1-c_p)^{1/2}$	± 1.9	∞
Sph. isotropy of the probe	± 9.6	rectangular	$\sqrt{3}$	$(c_p)^{1/2}$	± 3.9	∞
Probe linearity	± 4.7	rectangular	$\sqrt{3}$	1	± 2.7	∞
Detection limit	± 1.0	rectangular	$\sqrt{3}$	1	± 0.6	∞
Boundary effects	± 8.3	rectangular	$\sqrt{3}$	1	± 4.8	∞
Readout electronics	± 1.0	normal	1	1	± 1.0	∞
Response time	± 0.8	rectangular	$\sqrt{3}$	1	± 0.5	∞
Integration time	± 1.4	rectangular	$\sqrt{3}$	1	± 0.8	∞
Mech. constrains of robot	± 0.4	rectangular	$\sqrt{3}$	1	± 0.2	∞
Probe positioning	± 2.9	rectangular	$\sqrt{3}$	1	± 1.7	∞
Extrap. and integration	± 3.9	rectangular	$\sqrt{3}$	1	± 2.3	∞
RF ambient conditions	± 0.75	rectangular	$\sqrt{3}$	1	± 0.43	∞
Test Sample Related						
Device positioning	± 2.23	normal	1	1	± 2.23	11
Device holder uncertainty	± 5.0	normal	1	1	± 5.0	7
Power drift	± 5.0	rectangular	$\sqrt{3}$	1	± 2.9	∞
Phantom and Setup						
Phantom uncertainty	± 4.0	rectangular	$\sqrt{3}$	1	± 2.3	∞
Liquid conductivity (target)	± 5.0	rectangular	$\sqrt{3}$	0.6	± 1.7	∞
Liquid conductivity (meas.)	$\pm 10.0/5.0$	rectangular	$\sqrt{3}$	0.6	$\pm 3.5/1.73$	∞
Liquid permittivity (target)	± 5.0	rectangular	$\sqrt{3}$	0.6	± 1.7	∞
Liquid permittivity (meas.)	± 5.0	rectangular	$\sqrt{3}$	0.6	± 1.7	∞
Combined Standard Uncertainty					$\pm 12.14/11.76$	
Coverage Factor for 95%		kp = 2				
Expanded Standard Uncertainty					$\pm 24.29/23.51$	

Note: Due to the different spec for liquid above 2G (+/- 10%) and below the 2G (+/- 5%), the uncertainty budget is different accordingly.

6. EXPOSURE LIMIT

(A). Limits for Occupational/Controlled Exposure (W/kg)

Whole-Body	Partial-Body	Hands, Wrists, Feet and Ankles
0.4	8.0	20.0

(B). Limits for General Population/Uncontrolled Exposure (W/kg)

Whole-Body	Partial-Body	Hands, Wrists, Feet and Ankles
0.08	1.6	4.0

NOTE: **Whole-Body SAR** is averaged over the entire body, **partial-body SAR** is averaged over any 1 gram of tissue defined as a tissue volume in the shape of a cube. **SAR for hands, wrists, feet and ankles** is averaged over any 10 grams of tissue defined as a tissue volume in the shape of a cube.

Population/Uncontrolled Environments: are defined as locations where there is the exposure of individuals who have no knowledge or control of their exposure.

Occupational/Controlled Environments: are defined as locations where there is exposure that may be incurred by people who are aware of the potential for exposure, (i.e. as a result of employment or occupation).

<p>NOTE GENERAL POPULATION/UNCONTROLLED EXPOSURE PARTIAL BODY LIMIT 1.6 mW/g</p>

7. MEASUREMENT RESULTS

7.1. SYSTEM VALIDATION

Prior to the assessment, the system validation kit was used to test whether the system was operating within its specifications of $\pm 10\%$. The validation results are tabulated below. And also the corresponding SAR plot is attached as well in the SAR plots files.

IEEE P1528 Recommended Reference Value

Frequency (MHz)	1 g SAR	10 g SAR	Local SAR at surface (Above feed point)	Local SAR at surface (y=2cm offset from feed point)
300	3.0	2.0	4.4	2.1
450	4.9	3.3	7.2	3.2
835	9.5	6.2	14.1	4.9
900	10.8	6.9	16.4	5.4
1450	29.0	16.0	50.2	6.5
1800	38.1	19.8	69.5	6.8
1900	39.7	20.5	72.1	6.6
2000	41.1	21.1	74.6	6.5
2450	52.4	24.0	104.2	7.7
3000	63.8	25.7	140.2	9.5

System Validation Results

Measured Date: September 6, 2002

Ambient conditions - Ambient temperature: <u>23°C</u> ; Relative humidity: <u>61%</u>						
System Validation Dipole: <u>D900V2 SN: 108</u>				Depth of liquid: <u>15.1 cm</u>		
Liquid	Liquid Temp [°C]	Parameters	Target Value	Measured Value	Deviation [%]	Limit [%]
Head 900 MHz	22.4	ϵ_r	41.5	41.46	-0.096	± 5
		σ	0.97	0.966	-0.412	± 5
	22.4	1 g SAR	10.8	10.28	-4.81	± 10
Note: Please refer to Attachment for the result presentation in plot format.						

Measured Date: September 7, 2002

Ambient conditions - Ambient temperature: <u>23°C</u> ; Relative humidity: <u>60%</u>						
System Validation Dipole: <u>D1800V2 SN: 294</u>				Depth of liquid: <u>15.1 cm</u>		
Liquid	Liquid Temp [°C]	Parameters	Target Value	Measured Value	Deviation [%]	Limit [%]
Head 1800 MHz	22	ϵ_r	40	39.77	-0.575	± 5
		σ	1.4	1.345	-3.92	± 5
	22	1 g SAR	38.1	36.2	-4.98	± 10
Note: Please refer to attachment for the result presentation in plot format.						

7.2. TEST LIQUID CONFIRMATION

Simulated Tissue Liquid Parameter confirmation

The dielectric parameters were checked prior to assessment using the HP85070C dielectric probe kit. The dielectric parameters measured are reported in each correspondent section.

IEEE SCC-34/SC-2 P1528 recommended Tissue Dielectric Parameters

The head tissue dielectric parameters recommended by the IEEE SCC-34/SC-2 in P1528 have been incorporated in the following table. These head parameters are derived from planar layer models simulating the highest expected SAR for the dielectric properties and tissue thickness variations in a human head. Other head and body tissue parameters that have not been specified in P1528 are derived from the tissue dielectric parameters computed from the 4-Cole-Cole equations and extrapolated according to the head parameters specified in P1528

Target Frequency (MHz)	Head		Body	
	ϵ_r	σ (S/m)	ϵ_r	σ (S/m)
150	52.3	0.76	61.9	0.80
300	45.3	0.87	58.2	0.92
450	43.5	0.87	56.7	0.94
835	41.5	0.90	55.2	0.97
900	41.5	0.97	55.0	1.05
915	41.5	0.98	55.0	1.06
1450	40.5	1.20	54.0	1.30
1610	40.3	1.29	53.8	1.40
1800-2000	40.0	1.40	53.3	1.52
2450	39.2	1.80	52.7	1.95
3000	38.5	2.40	52.0	2.73
5800	45.3	5.27	48.2	6.00

(ϵ_r = relative permittivity, σ = conductivity and $\rho = 1000 \text{ kg/m}^3$)

Liquid Confirmation Results

Measured date: September 6, 2002

Ambient Conditions - Ambient temperature: <u>23°C</u> ; Relative Humidity: <u>61%</u>						
Liquid	Temp. [°C]	Parameters	Target Value	Measured	Deviation [%]	Limit [%]
Muscle 835 MHz	22.4	ϵ_r	55.2	54.49	-1.28	±5
		σ	0.97	0.930	-4.12	±5

Measured date: September 7, 2002

LIQUID VERIFY						
Ambient Conditions - Ambient temperature: <u>23°C</u> ; Relative Humidity: <u>60%</u>						
Liquid	Temp. [°C]	Parameters	Target Value	Measured	Deviation [%]	Limit [%]
Muscle 1900 MHz	22.0	ϵ_r	53.3	51.96	-2.514	±5
		σ	1.52	1.446	-4.868	±5

7.3. EUT TUNE-UP PROCEDURE

- To stabilize the power drift, the EUT was allowed to warm up for 40 minutes in the laptop. Then the output power was adjusted to the specified maximum limit using AT commands supplied by the manufacturer. The output power was monitored and fine-tuned for another 10 minutes to ensure EUT power drift was stabilized.
- Maximum average conducted power was measured by replacing the antenna with an adapter for conductive measurements, before and after the SAR measurements was done.

8. EUT SETUP PHOTOS

EUT Set-up Configuration 1

1. Installation conditions between host device and phantom - Host device perpendicular to flat phantom.
2. Spacing between host device and phantom - 1.5 cm (Measured from central of antenna).
3. Spacing between antenna and phantom - 1.5 cm (Measured from central of antenna).



EUT Set-up Configuration 2

1. Installation conditions between host device and phantom - Bottom face in parallel with flat phantom.
2. Spacing between host device and phantom - In contact (0 cm).
3. Spacing between antenna and phantom - 1.3 cm (Measured from central of antenna).



EUT SETUP PHOTOS (CONTINUE)

EUT Set-up Configuration 3

1. Installation conditions between host device and phantom - Bottom face in parallel with flat phantom.
2. Spacing between host device and phantom - In contact (0 cm).
3. Spacing between antenna and phantom - 1.3 cm (Measured from central of antenna).

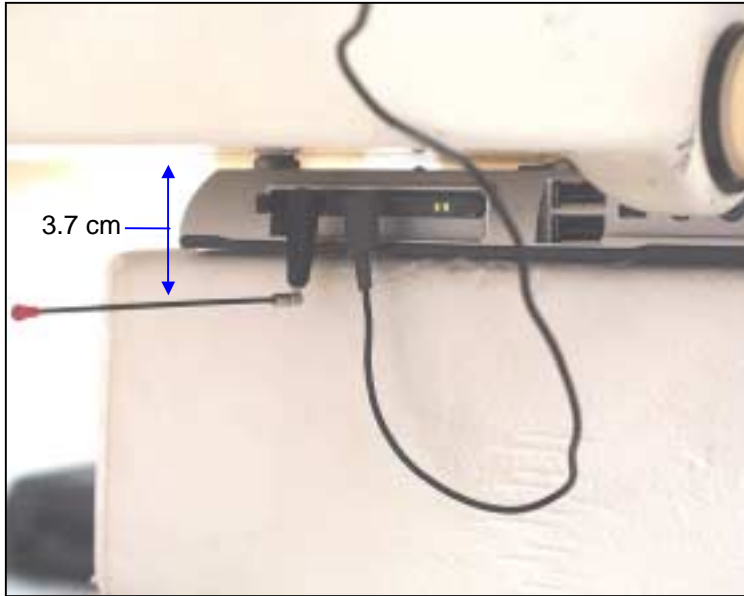

EUT Set-up Configuration 4

1. Installation conditions between host device and phantom - Bottom face in parallel with flat phantom.
2. Spacing between host device and phantom - In contact (0 cm).
3. Spacing between antenna and phantom - 1.3 cm (Measured from central of antenna).



8.1. SAR MEASUREMENT RESULT

8.1.1. CELL 835 MHz

Measured date: September 6, 2002

SAR MEASUREMENT								
Crest factor: <u>1</u>				Depth of liquid: <u>15.1 cm</u>				
EUT: <u>AirCard 555 installed to Laptop PC</u>				Laptop PC - <u>Gateway, model 450SX4, S/N: 0027789009</u>				
Phantom Section: <u>Flat (Body) position (See EUT set-up configuration 1)</u>								
EUT Set-up conditions				Conducted Power [dBm]		Liquid Temp [°C]	SAR (W/kg) Measured	
Channel	Frequency [MHz]	Antenna position	Sep. [mm]	Before	After		1 g	10 g
991	824.04	Vertical	15	23.12	23.06	21.2	1.08	0.708
384	836.52	Vertical	15	23.10	23.05	21.3	0.668	0.439
799	848.97	Vertical	15	23.11	23.02	21.1	1.05	0.687
Phantom Section: <u>Flat (Body) position (See EUT set-up configuration 2)</u>								
991	824.04	Vertical	Touched to phantom	23.12	23.06	21.2	0.0805	0.0536
384	836.52	Vertical	ditto	23.10	23.05	21.1	0.0393	0.0264
799	848.97	Vertical	ditto	23.11	23.02	21.0	0.0341	0.0227
Phantom Section: <u>Flat (Body) position (See EUT set-up configuration 3)</u>								
991	824.04	Vertical	Touched to phantom	23.12	23.06	21.0	0.256	0.183
384	836.52	Vertical	ditto	23.10	23.05	21.1	0.169	0.122
799	848.97	Vertical	ditto	23.11	23.02	21.1	0.254	0.182
Phantom Section: <u>Flat (Body) position (See EUT set-up configuration 4)</u>								
991	824.04	Horizontal	Touched to phantom	23.12	23.06	22.3	1.08	0.706
384	836.52	Horizontal	ditto	23.10	23.05	21.9	0.821	0.530
799	848.97	Horizontal	ditto	23.11	23.02	22.0	1.11	0.715
Note (s): Please refer to attachment for each configuration presentation in plot format.								

8.1.2. PCS 1900 MHz

Measured date: September 7, 2002

SAR MEASUREMENT								
Crest factor: 1				Depth of liquid: 15.1 cm				
EUT: AirCard 555 installed to Laptop PC								
Laptop PC - Gateway, model 450SX4, S/N: 0027789009								
Phantom Section: Flat (Body) position (See EUT set-up configuration 1)								
EUT Set-up conditions				Conducted Power [dBm]		Liquid Temp [°C]	SAR (W/kg) Measured	
Channel	Frequency [MHz]	Antenna position	Sep. [mm]	Before	After		1 g	10 g
L (1)	1850	Vertical	15	23.05	23.01	21.9	0.676	0.378
M (600)	1880	Vertical	15	23.04	23.01	22.0	0.781	0.434
H (1199)	1909.95	Vertical	15	23.03	23.00	22.2	0.757	0.418
Phantom Section: Flat (Body) position (See EUT set-up configuration 2)								
L (1)	1850	Vertical	Touched to phantom	23.05	23.01	22.3	0.215	0.120
M (600)	1880	Vertical	ditto	23.04	23.01	22.3	0.214	0.118
H (1199)	1909.95	Vertical	ditto	23.03	23.00	22.2	0.180	0.101
Phantom Section: Flat (Body) position (See EUT set-up configuration 3)								
L (1)	1850	Vertical	Touched to phantom	23.05	23.01	22.5	0.376	0.216
M (600)	1880	Vertical	ditto	23.04	23.01	22.5	0.308	0.184
H (1199)	1909.95	Vertical	ditto	23.03	23.00	22.4	0.328	0.189
Phantom Section: Flat (Body) position (See EUT set-up configuration 4)								
L (1)	1850	Horizontal	Touched to phantom	23.05	23.01	22.5	0.856	0.481
M (600)	1880	Horizontal	ditto	23.04	23.01	22.5	1.22	0.672
H (1199)	1909.95	Horizontal	ditto	23.03	23.00	22.4	1.05	0.578
Note (s): Please refer to attachment for each configuration presentation in plot format.								

9. EUT PHOTOS

Laptop PC: Gateway
Model Name: 450SX4
Serial Number: 0027789009



EUT PHOTOS



10. EQUIPMENTS LIST & CALIBRATION STATUS

Name of Equipment	Manufacturer	Type/Model	Serial Number	Calibration	
				last cal.	due date
S-Parameter Network Analyzer	Agilent	8753ES	MY40001647	8/6/02	8/6/03
Electronic Probe kit	Hewlett Packard	85070C	N/A	N/A	N/A
3.5 mm Calibration Kit	Agilent	85033D	3423A07200	8/6/02	8/6/03
Power Meter	Rohde & Schwarz	NRVD	842093/017	1/21/02	1/21/03
Power Sensor	Rohde & Schwarz	NRV-Z51	841275/013	1/21/02	1/21/03
Universal Radio Communication Tester	Rohde & Schwarz	CMU 200	838114/032	11/20/01	11/20/02
Amplifier	Mini-Circuit	ZHL-42W	D072701-5	N/A	N/A
DC Power generator	Kenwood	PA36-3A	7060074	N/A	N/A
Data Acquisition Electronics (DAE)	SPEAG	DAE3 V1	500	2/26/02	2/26/03
Dosimetric E-Field Probe	SPEAG	ET3DV6	1578	2/22/01	2/22/03
450 MHz System Validation Dipole	SPEAG	D450V2	1003	4/5/02	4/19/04
900 MHz System Validation Dipole	SPEAG	D900V2	108	4/17/01	4/17/03
1800 MHz System Validation Dipole	SPEAG	D1800V2	294	4/19/01	4/19/03
2450 MHz System Validation Dipole	SPEAG	D2450V2	706	6/4/02	6/4/04
Probe Alignment Unit	SPEAG	LB (V2)	261	N/A	N/A
Robot	Staubli	RX90B L	F00/5H31A1/A/01	N/A	N/A
Generic Twin Phantom	SPEAG	N/A	N/A	N/A	N/A
SAM Phantom	SPEAG	N/A	N/A	N/A	N/A
Devices Holder	SPEAG	N/A	N/A	N/A	N/A
Head 450 MHz	CCS	H450A	N/A	Daily	N/A
Muscle 450 MHz	CCS	M450A	N/A	Daily	N/A
Head 835 MHz	CCS	H835A	N/A	Daily	N/A
Muscle 835 MHz	CCS	M835A	N/A	Daily	N/A
Head 900 MHz	CCS	H900A	N/A	Daily	N/A
Muscle 900 MHz	CCS	M900A	N/A	Daily	N/A
Head 1800 MHz	CCS	H1800A	N/A	Daily	N/A
Muscle 1800 MHz	CCS	M1800A	N/A	Daily	N/A
Head 1900 MHz	CCS	H1900A	N/A	Daily	N/A
Muscle 1900 MHz	CCS	M1900A	N/A	Daily	N/A
Head 2450 MHz	CCS	H2450A	N/A	Daily	N/A
Muscle 2450 MHz	CCS	M2450A	N/A	Daily	N/A

11. REFERENCES

- [1] Federal Communications Commission, "Report and order: Guidelines for evaluating the environmental effects of radiofrequency radiation", Tech. Rep. FCC 96-326, FCC, Washington, D.C. 20554, 1996.
- [2] David L. Means Kwok Chan, Robert F. Cleveland, "Evaluating compliance with FCC guidelines for human exposure to radiofrequency electromagnetic fields", Tech. Rep., Federal Communication Commission, Office of Engineering & Technology, Washington, DC, 1997.
- [3] Thomas Schmid, Oliver Egger, and Niels Kuster, "Automated E-field scanning system for dosimetric assessments", IEEE Transactions on Microwave Theory and Techniques, vol. 44, pp. 105-113, Jan. 1996.
- [4] Niels Kuster, Ralph Kastle, and Thomas Schmid, "Dosimetric evaluation of mobile communications equipment with known precision", IEEE Transactions on Communications, vol. E80-B, no. 5, pp. 645-652, May 1997.
- [5] CENELEC, "Considerations for evaluating of human exposure to electromagnetic fields (EMFs) from mobile telecommunication equipment (MTE) in the frequency range 30MHz - 6GHz", Tech. Rep., CENELEC, European Committee for Electrotechnical Standardization, Brussels, 1997.
- [6] ANSI, ANSI/IEEE C95.1-1992: IEEE Standard for Safety Levels with Respect to Human Exposure to Radio Frequency Electromagnetic Fields, 3 kHz to 300 GHz, The Institute of Electrical and Electronics Engineers, Inc., New York, NY 10017, 1992.
- [7] Katja Pokovic, Thomas Schmid, and Niels Kuster, "Robust setup for precise calibration of E-field probes in tissue simulating liquids at mobile communications frequencies", in ICECOM '97, Dubrovnik, October 15-17, 1997, pp. 120-124.
- [8] Katja Pokovic, Thomas Schmid, and Niels Kuster, "E-field probe with improved isotropy in brain simulating liquids", in Proceedings of the ELMAR, Zadar, Croatia, 23-25 June, 1996, pp. 172-175.
- [9] Volker Hombach, Klaus Meier, Michael Burkhardt, Eberhard Kuhn, and Niels Kuster, "The dependence of EM energy absorption upon human head modeling at 900 MHz", IEEE Transactions on Microwave Theory and Techniques, vol. 44, no. 10, pp. 1865-1873, Oct. 1996.
- [10] Klaus Meier, Ralf Kastle, Volker Hombach, Roger Tay, and Niels Kuster, "The dependence of EM energy absorption upon human head modeling at 1800 MHz", IEEE Transactions on Microwave Theory and Techniques, Oct. 1997, in press.
- [11] W. Gander, Computermathematik, Birkhaeuser, Basel, 1992.
- [12] W. H. Press, S. A. Teukolsky, W. T. Vetterling, and B. P. Flannery, Numerical Recipes in C, The Art of Scientific Computing, Second Edition, Cambridge University Press, 1992. Dosimetric Evaluation of Sample device, month 1998 9
- [13] NIS81 NAMAS, "The treatment of uncertainty in EMC measurement", Tech. Rep., NAMAS Executive, National Physical Laboratory, Teddington, Middlesex, England, 1994.
- [14] Barry N. Taylor and Christ E. Kuyatt, "Guidelines for evaluating and expressing the uncertainty of NIST measurement results", Tech. Rep., National Institute of Standards and Technology, 1994. Dosimetric Evaluation of Sample device, month 1998 10

12. ATTACHMENT

Exhibit	Content	No. of page (s)
1	System Validation Plots	4
2	Dosimetric E-Field Probe - ET3DV6, S/N: 1578	12
3	Validation Dipole – D900V2, S/N: 108	7
4	Validation Dipole – D1800V2, S/N: 294	7
5	SAR Test Plots - CDMA835MHz	24
6	SAR Test Plots – PCS1900MHz	24

End of Report

System Validation - D900V2 SN: 108

(Antenna input power: 250 mW)

SAM-2; Flat

Probe: ET3DV6 - SN1578; ConvF(7.00,7.00,7.00); Crest factor: 1.0

Head 900 MHz: $\sigma = 0.97$ mho/m $\epsilon_r = 41.5$ $\rho = 1.00$ g/cm³

Cube 5x5x7: Peak: 4.09 mW/g, SAR (1g): 2.57 mW/g, SAR (10g): 1.62 mW/g, (Worst-case extrapolation)

Penetration depth: 11.6 (10.7, 12.8) [mm]

Powerdrift: -0.00 dB

Ambient Temperature (degree C): 23

Liquid Temperature (degree C): 22.4

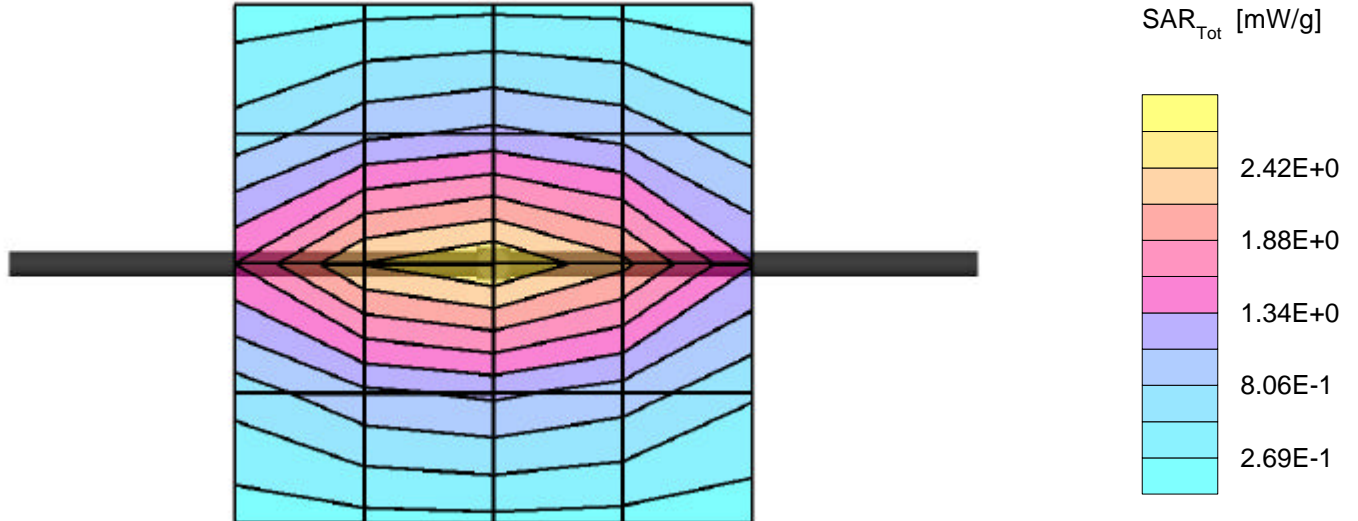

System Validation - D900V2 SN: 108

(Antenna input power: 250 mW)

SAM-2;

Probe: ET3DV6 - SN1578; ConvF(7.00,7.00,7.00); Crest factor: 1.0

Head 900 MHz: $\sigma = 0.97$ mho/m $\epsilon_r = 41.5$ $\rho = 1.00$ g/cm³

: , , ()

Penetration depth: 11.7 (10.7, 12.9) [mm]

Ambient Temperature (degree C): 23

Liquid Temperature (degree C): 22.4

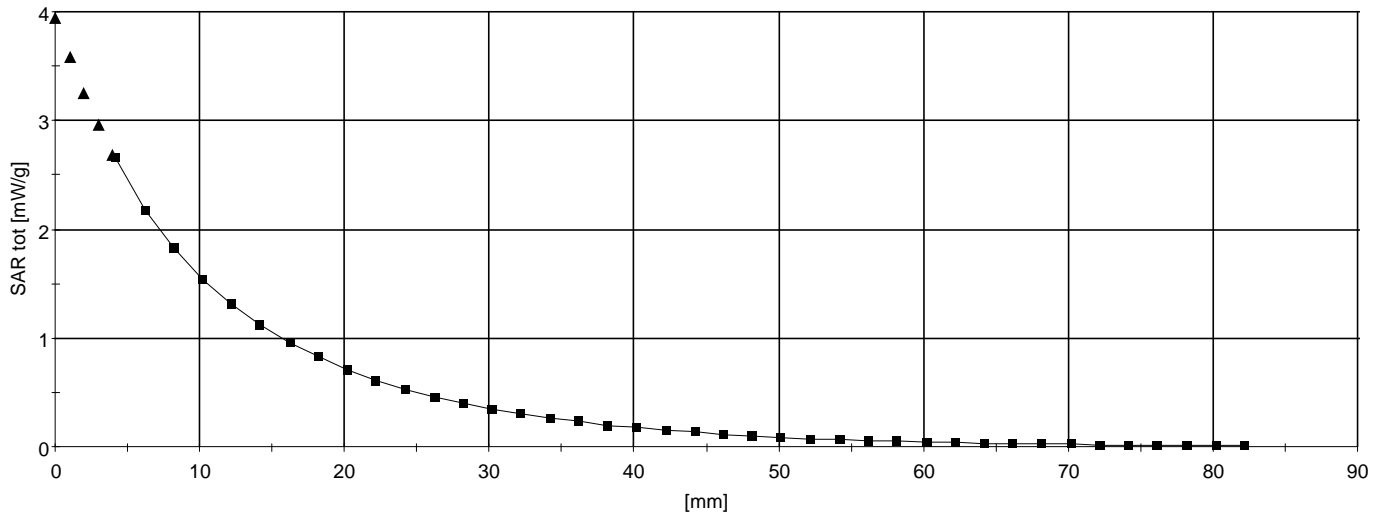

System Validation - D1800V2 S/N: 294

(Antenna input power: 250 mW)

SAM-2; Flat

Probe: ET3DV6 - SN1578; ConvF(5.50,5.50,5.50); Crest factor: 1.0

Head 1800 MHz: $\sigma = 1.35$ mho/m $\epsilon_r = 39.8$ $\rho = 1.00$ g/cm³

Cube 5x5x7: Peak: 16.6 mW/g, SAR (1g): 9.05 mW/g, SAR (10g): 4.77 mW/g, (Worst-case extrapolation)

Penetration depth: 8.4 (8.0, 9.3) [mm]

Powerdrift: -0.02 dB

Ambient Temperature (degree C): 23

Liquid Temperature (degree C): 22.0

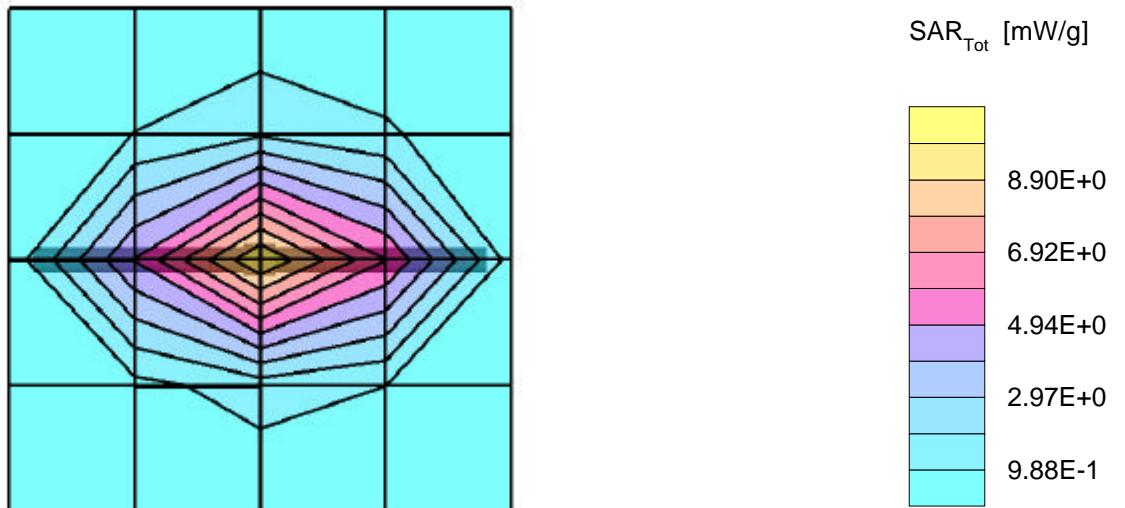

System Validation - D1800V2 S/N: 294

(Antenna input power: 250 mW)

SAM-2;

Probe: ET3DV6 - SN1578; ConvF(5.50,5.50,5.50); Crest factor: 1.0

Head 1800 MHz: $\sigma = 1.35 \text{ mho/m}$ $\epsilon_r = 39.8$ $\rho = 1.00 \text{ g/cm}^3$

: , , ()

Penetration depth: 8.5 (8.0, 9.4) [mm]

Ambient Temperature (degree C): 23

Liquid Temperature (degree C): 22.0

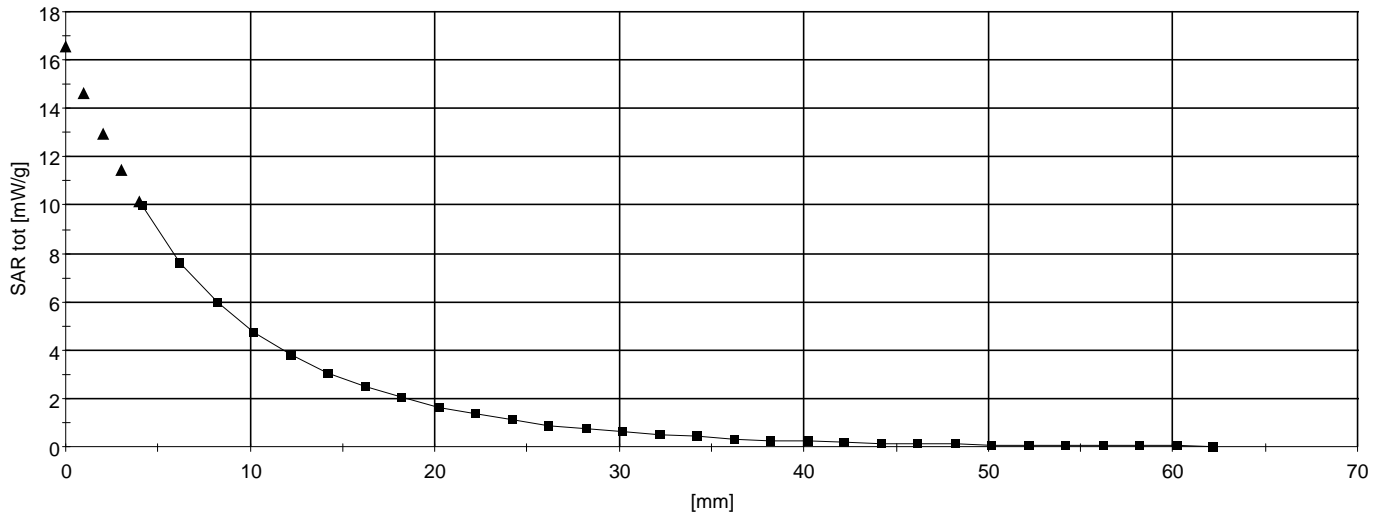

Probe ET3DV6

SN:1578

Manufactured:	April 6, 2001
Last calibration:	April 20, 2001
Recalibrated:	February 22, 2002

Calibrated for System DASY3

DASY3 - Parameters of Probe: ET3DV6 SN:1578

Sensitivity in Free Space

NormX	1.72 $\mu\text{V}/(\text{V}/\text{m})^2$
NormY	1.83 $\mu\text{V}/(\text{V}/\text{m})^2$
NormZ	1.68 $\mu\text{V}/(\text{V}/\text{m})^2$

Diode Compression

DCP X	99	mV
DCP Y	99	mV
DCP Z	99	mV

Sensitivity in Tissue Simulating Liquid

Head	900 MHz	$\epsilon_r = 41.5 \pm 5\%$	$\sigma = 0.97 \pm 5\%$ mho/m
Head	835 MHz	$\epsilon_r = 41.5 \pm 5\%$	$\sigma = 0.90 \pm 5\%$ mho/m
	ConvF X	7.0 $\pm 9.5\%$ (k=2)	Boundary effect:
	ConvF Y	7.0 $\pm 9.5\%$ (k=2)	Alpha 0.33
	ConvF Z	7.0 $\pm 9.5\%$ (k=2)	Depth 2.34
Head	1800 MHz	$\epsilon_r = 40.0 \pm 5\%$	$\sigma = 1.40 \pm 5\%$ mho/m
Head	1900 MHz	$\epsilon_r = 40.0 \pm 5\%$	$\sigma = 1.40 \pm 5\%$ mho/m
	ConvF X	5.5 $\pm 9.5\%$ (k=2)	Boundary effect:
	ConvF Y	5.5 $\pm 9.5\%$ (k=2)	Alpha 0.47
	ConvF Z	5.5 $\pm 9.5\%$ (k=2)	Depth 2.20

Boundary Effect

Head	900 MHz	Typical SAR gradient: 5 % per mm	
	Probe Tip to Boundary	1 mm	2 mm
	SAR _{be} [%] Without Correction Algorithm	7.6	4.3
	SAR _{be} [%] With Correction Algorithm	0.2	0.4
Head	1800 MHz	Typical SAR gradient: 10 % per mm	
	Probe Tip to Boundary	1 mm	2 mm
	SAR _{be} [%] Without Correction Algorithm	9.5	6.3
	SAR _{be} [%] With Correction Algorithm	0.2	0.3

Sensor Offset

Probe Tip to Sensor Center	2.7	mm
Optical Surface Detection	1.5 \pm 0.2	mm

Receiving Pattern (ϕ), $\theta = 0^\circ$

f = 30 MHz, TEM cell ifi110

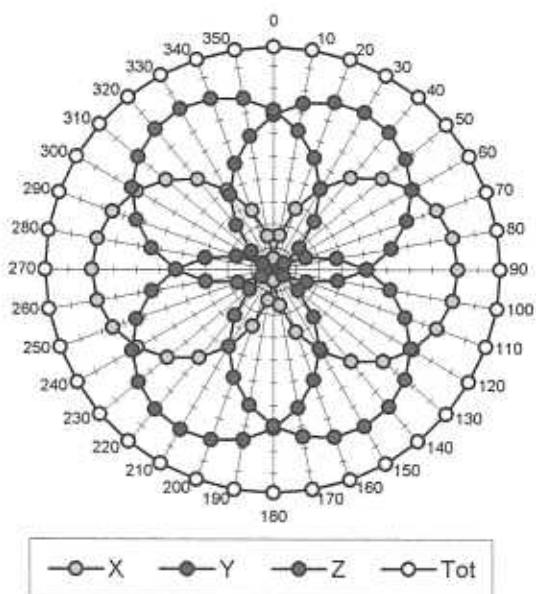

f = 100 MHz, TEM cell ifi110

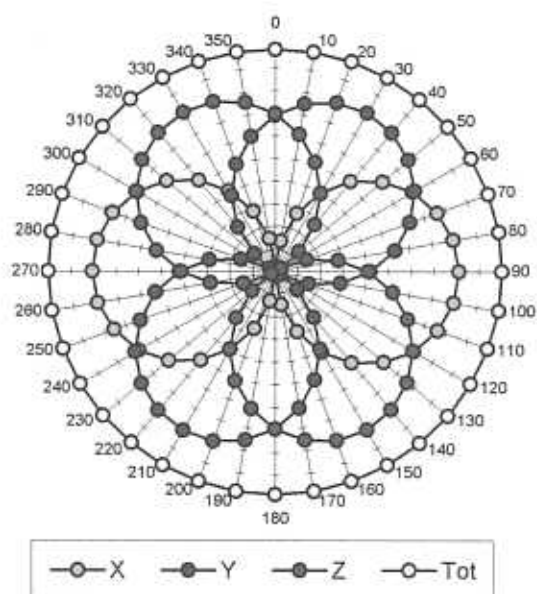

f = 300 MHz, TEM cell ifi110

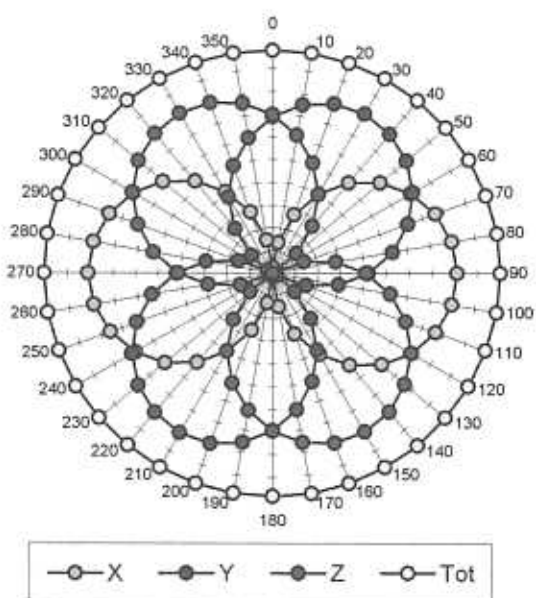

f = 900 MHz, TEM cell ifi110

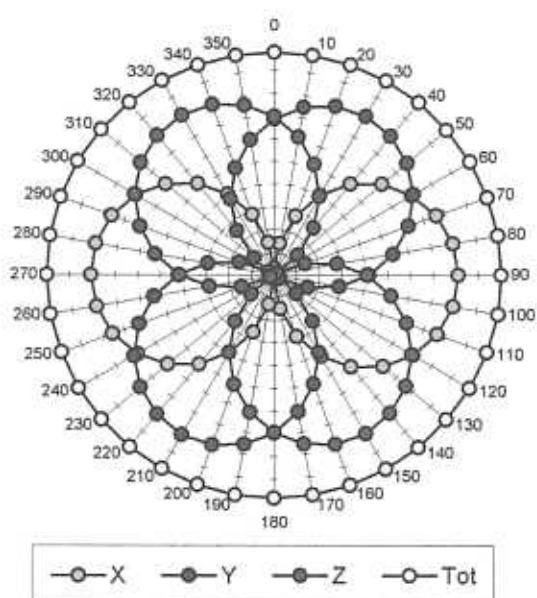

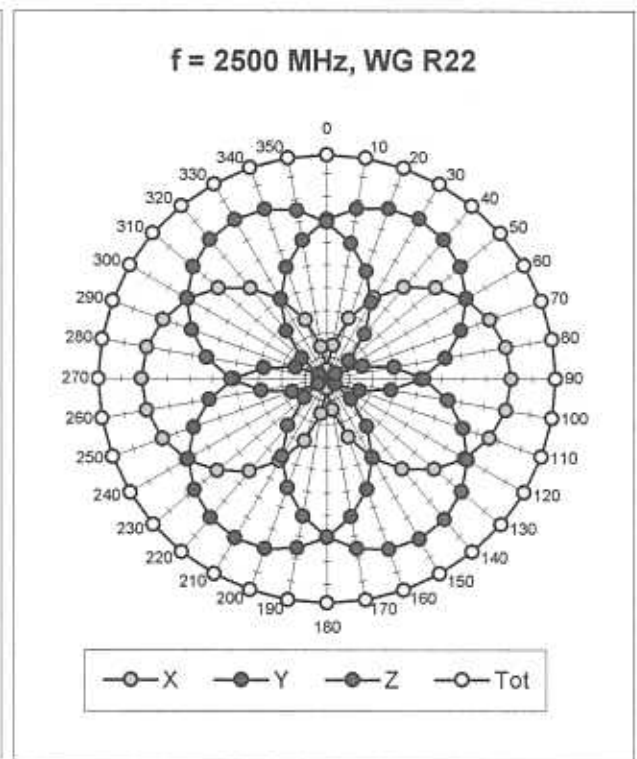
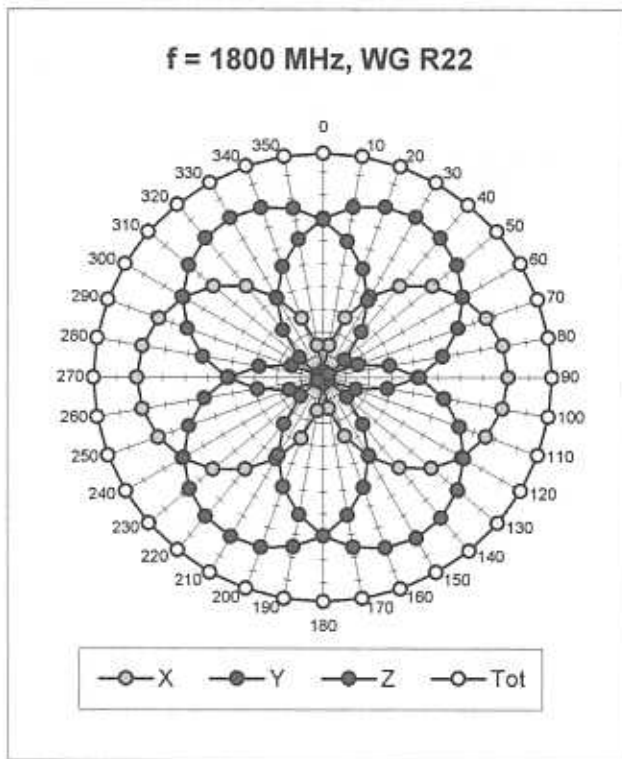

Isotropy Error (ϕ), $\theta = 0^\circ$

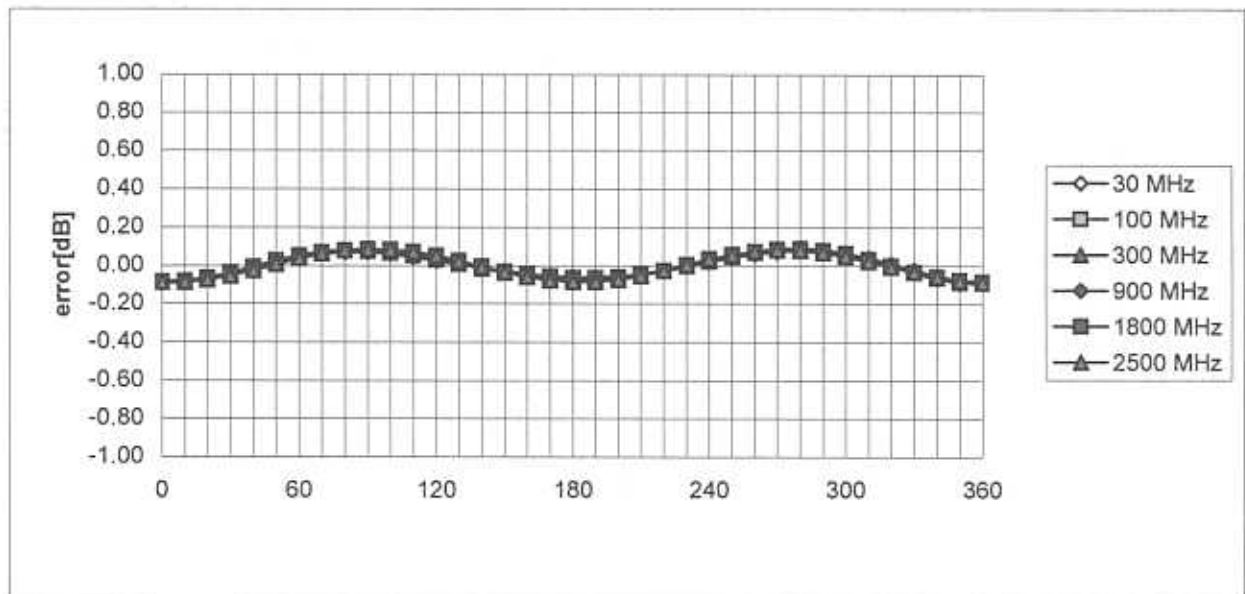

Frequency Response of E-Field

(TEM-Cell:ifi110, Waveguide R22)

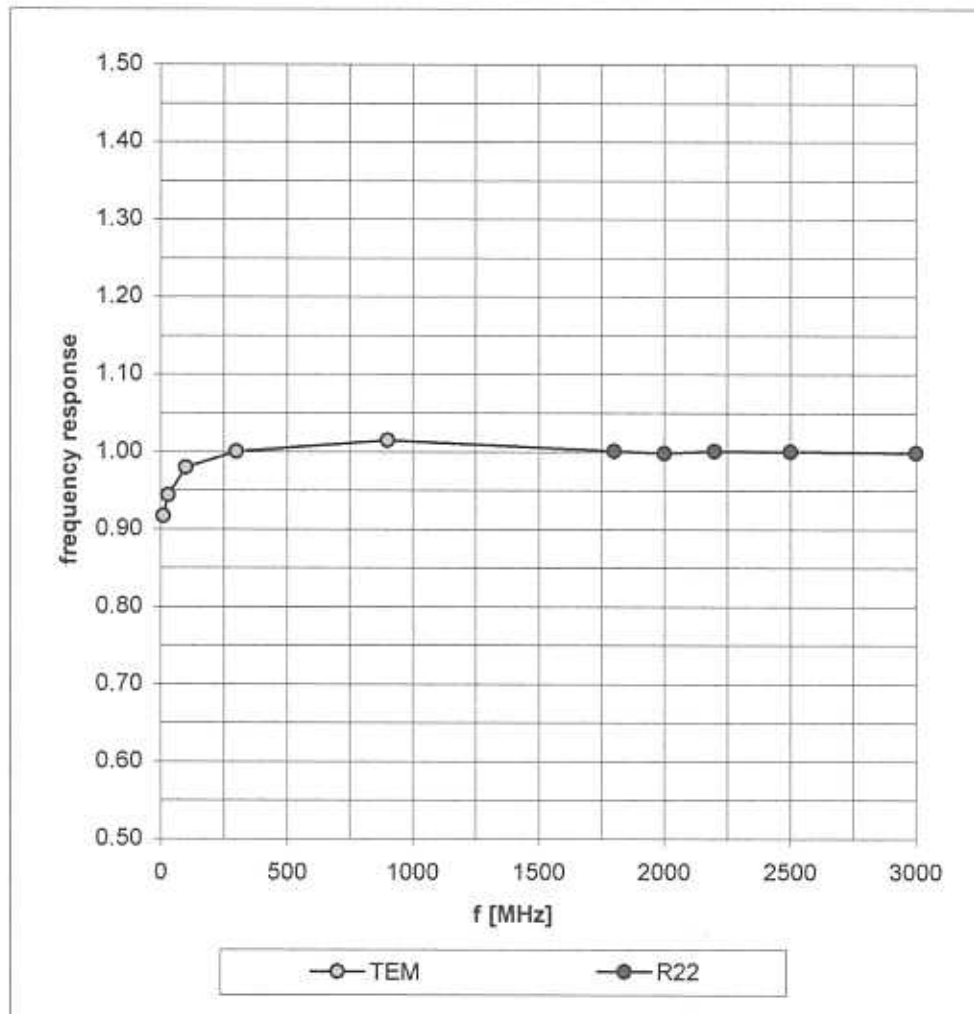

Dynamic Range f(SAR_{brain})

(Waveguide R22)

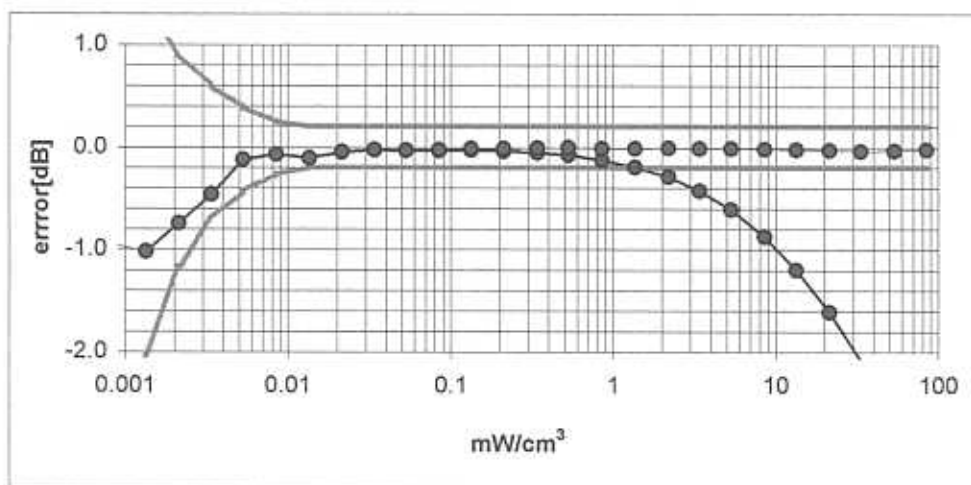
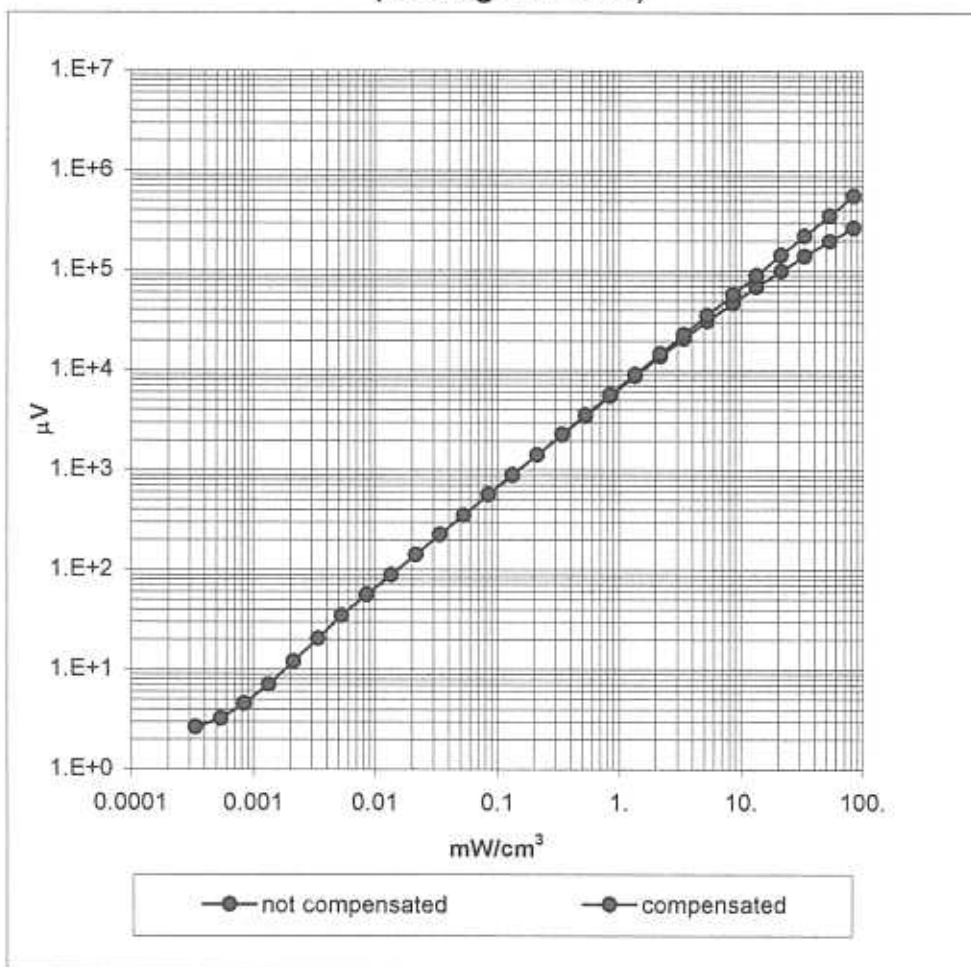

Conversion Factor Assessment

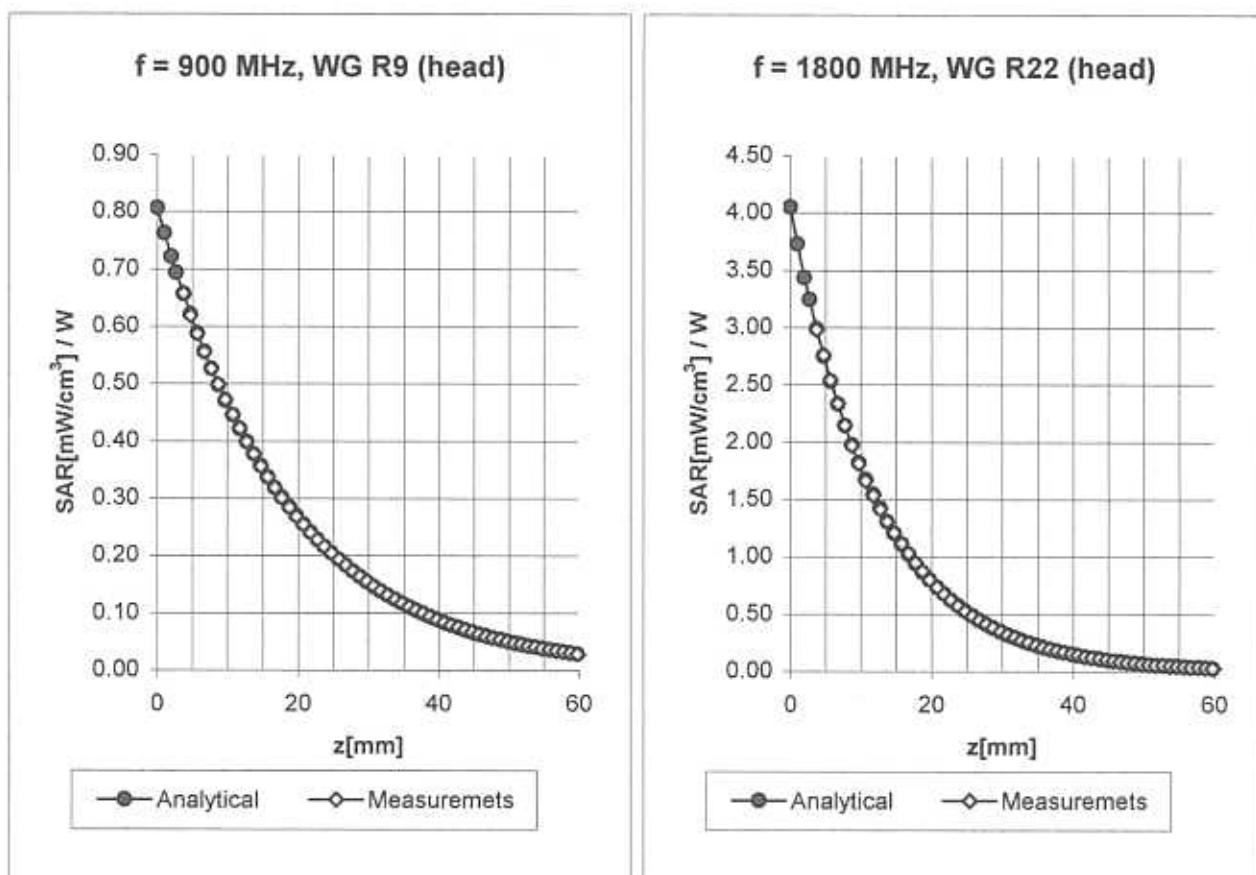

Head	900 MHz	$\epsilon_r = 41.5 \pm 5\%$	$\sigma = 0.97 \pm 5\%$ mho/m
Head	835 MHz	$\epsilon_r = 41.5 \pm 5\%$	$\sigma = 0.90 \pm 5\%$ mho/m
	ConvF X	7.0 $\pm 9.5\%$ (k=2)	Boundary effect:
	ConvF Y	7.0 $\pm 9.5\%$ (k=2)	Alpha 0.33
	ConvF Z	7.0 $\pm 9.5\%$ (k=2)	Depth 2.34
Head	1800 MHz	$\epsilon_r = 40.0 \pm 5\%$	$\sigma = 1.40 \pm 5\%$ mho/m
Head	1900 MHz	$\epsilon_r = 40.0 \pm 5\%$	$\sigma = 1.40 \pm 5\%$ mho/m
	ConvF X	5.5 $\pm 9.5\%$ (k=2)	Boundary effect:
	ConvF Y	5.5 $\pm 9.5\%$ (k=2)	Alpha 0.47
	ConvF Z	5.5 $\pm 9.5\%$ (k=2)	Depth 2.20

Conversion Factor Assessment

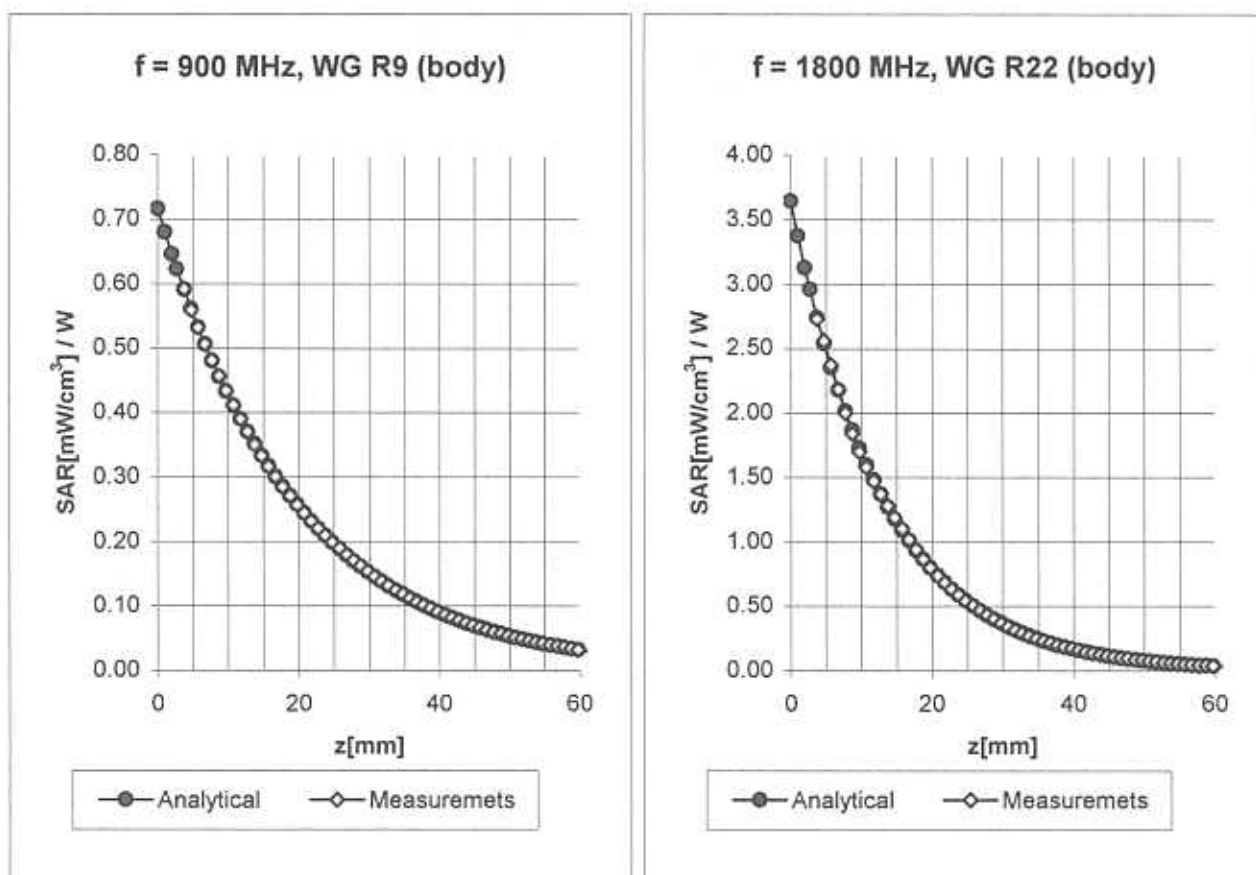

Body	900 MHz	$\epsilon_r = 55.0 \pm 5\%$	$\sigma = 1.05 \pm 5\%$ mho/m
Body	835 MHz	$\epsilon_r = 55.2 \pm 5\%$	$\sigma = 0.97 \pm 5\%$ mho/m
	ConvF X	6.7 $\pm 9.5\%$ (k=2)	Boundary effect:
	ConvF Y	6.7 $\pm 9.5\%$ (k=2)	Alpha 0.29
	ConvF Z	6.7 $\pm 9.5\%$ (k=2)	Depth 2.76
Body	1800 MHz	$\epsilon_r = 53.3 \pm 5\%$	$\sigma = 1.52 \pm 5\%$ mho/m
Body	1900 MHz	$\epsilon_r = 53.3 \pm 5\%$	$\sigma = 1.52 \pm 5\%$ mho/m
	ConvF X	5.1 $\pm 9.5\%$ (k=2)	Boundary effect:
	ConvF Y	5.1 $\pm 9.5\%$ (k=2)	Alpha 0.58
	ConvF Z	5.1 $\pm 9.5\%$ (k=2)	Depth 2.19

Deviation from Isotropy in HSL

Error (θ, ϕ), $f = 900$ MHz

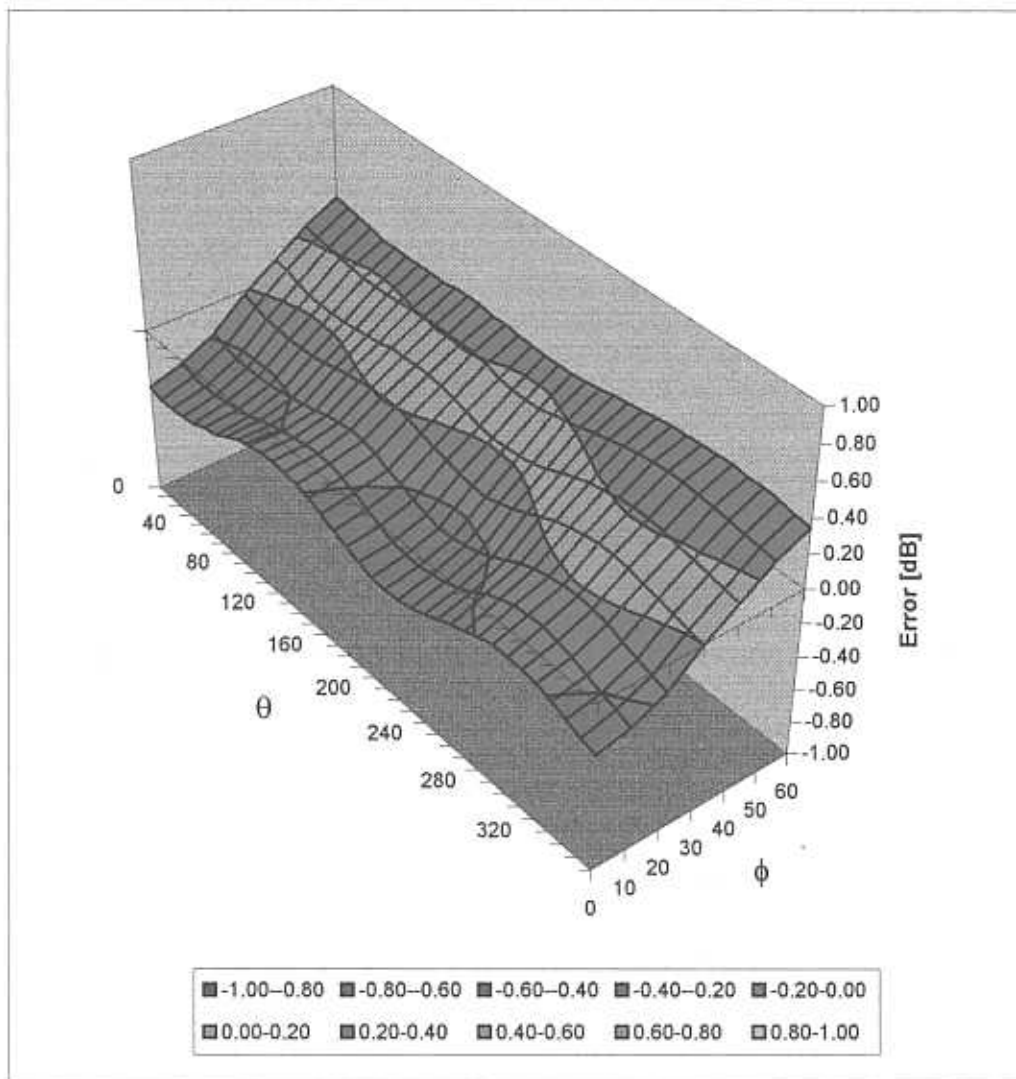

Additional Conversion Factors for Dosimetric E-Field Probe

Type:

ET3DV6

Serial Number:

1578

Place of Assessment:

Zurich

Date of Assessment:

February 25, 2002

Probe Calibration Date:

February 22, 2002

Schmid & Partner Engineering AG hereby certifies that conversion factor(s) of this probe have been evaluated on the date indicated above. The assessment was performed using the FDTD numerical code SEMCAD of Schmid & Partner Engineering AG. Since the evaluation is coupled with measured conversion factors, it has to be recalculated yearly, i.e., following the re-calibration schedule of the probe. The uncertainty of the numerical assessment is based on the extrapolation from measured value at 900 MHz or at 1800 MHz.

Assessed by:

Polonik Katja

Dosimetric E-Field Probe ET3DV6 SN:1578

Conversion factor (\pm standard deviation)

450 MHz	ConvF	8.0 \pm 8%	$\epsilon_r = 43.5$ $\sigma = 0.87$ mho/m (head tissue)
450 MHz	ConvF	8.1 \pm 8%	$\epsilon_r = 56.7$ $\sigma = 0.94$ mho/m (body tissue)
2450 MHz	ConvF	4.5 \pm 8%	$\epsilon_r = 39.2$ $\sigma = 1.80$ mho/m (head tissue)
2450 MHz	ConvF	4.1 \pm 8%	$\epsilon_r = 52.7$ $\sigma = 1.95$ mho/m (body tissue)

Calibration Certificate

900 MHz System Validation Dipole

Type:

D900V2

Serial Number:

108

Place of Calibration:

Zurich

Date of Calibration:

Apr. 17, 2001

Calibration Interval:

24 months

Schmid & Partner Engineering AG hereby certifies, that this device has been calibrated on the date indicated above. The calibration was performed in accordance with specifications and procedures of Schmid & Partner Engineering AG.

Wherever applicable, the standards used in the calibration process are traceable to international standards. In all other cases the standards of the Laboratory for EMF and Microwave Electronics at the Swiss Federal Institute of Technology (ETH) in Zurich, Switzerland have been applied.

Calibrated by:

Volker Kabis

Approved by:

[Signature]

1. Measurement Conditions

The measurements were performed in the flat section of the new generic twin phantom filled with head simulating solution of the following electrical parameters at 900 MHz:

Relative Dielectricity	41.2	$\pm 5\%$
Conductivity	0.95 mho/m	$\pm 5\%$

The DASY3 System (Software version 3.1c) with a dosimetric E-field probe ET3DV6 (SN:1507, Conversion factor 6.27 at 900 MHz) was used for the measurements.

The dipole was mounted on the small tripod so that the dipole feedpoint was positioned below the center marking of the flat phantom section and the dipole was oriented parallel to the body axis (the long side of the phantom). The standard measuring distance was 15mm from dipole center to the solution surface. The included distance holder was used during measurements for accurate distance positioning.

The coarse grid with a grid spacing of 15mm was aligned with the dipole. The 5x5x7 fine cube was chosen for cube integration. Probe isotropy errors were cancelled by measuring the SAR with normal and 90° turned probe orientations and averaging.

The dipole input power (forward power) was 250mW $\pm 3\%$. The results are normalized to 1W input power.

2. SAR Measurement

Standard SAR-measurements were performed with the phantom according to the measurement conditions described in section 1. The results have been normalized to a dipole input power of 1W (forward power). The resulting averaged SAR-values are:

averaged over 1 cm ³ (1 g) of tissue:	11.2 mW/g
averaged over 10 cm ³ (10 g) of tissue:	7.08 mW/g

Note: If the liquid parameters for validation are slightly different from the ones used for initial calibration, the SAR-values will be different as well.

3. Dipole Impedance and Return Loss

The impedance was measured at the SMA-connector with a network analyzer and numerically transformed to the dipole feedpoint. The transformation parameters from the SMA-connector to the dipole feedpoint are:

Electrical delay:	1.416 ns	(one direction)
Transmission factor:	0.987	(voltage transmission, one direction)

The dipole was positioned at the flat phantom sections according to section 1 and the distance holder was in place during impedance measurements.

Feedpoint impedance at 900 MHz:	$\text{Re}\{Z\} = 55.4 \Omega$
	$\text{Im}\{Z\} = 1.1 \Omega$
Return Loss at 900 MHz	-25.6 dB

4. Handling

The dipole is made of standard semirigid coaxial cable. The center conductor of the feeding line is directly connected to the second arm of the dipole. The antenna is therefore short-circuited for DC-signals.

Do not apply excessive force to the dipole arms, because they might bend. If the dipole arms have to be bent back, take care to release stress to the soldered connections near the feedpoint; they might come off.

After prolonged use with 100W radiated power, only a slight warming of the dipole near the feedpoint can be measured.

Validation Dipole D900V2 SN:108, d = 15 mm

Frequency: 900 MHz; Antenna Input Power: 250 [mW]
 Generic: Twin Phantom; Flat Section; Grid Spacing: Dx = 15.0, Dy = 15.0, Dz = 10.0
 Probe: ET3DV6 - SN1507; ConvF(6.27,6.27,6.27) at 900 MHz; IEEE1528 900 MHz; $\sigma = 0.95$ mho/m $\epsilon_r = 41.2$ $\rho = 1.00$ g/cm³
 Cubes (2): Peak: 4.52 mW/g \pm 0.03 dB, SAR (1g): 2.80 mW/g \pm 0.02 dB, SAR (10g): 1.77 mW/g \pm 0.02 dB, (Worst-case extrapolation)
 Penetration depth: 11.5 (10.3, 13.1) [mm]
 Powerdrit: 0.01 dB

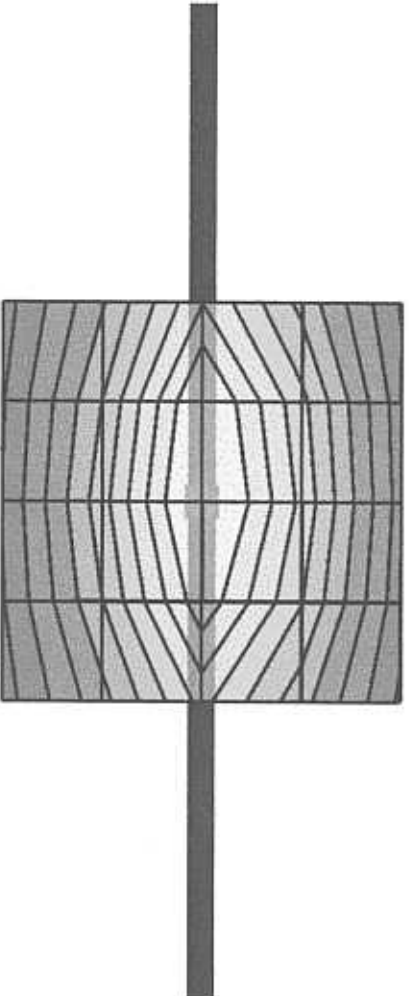

SAR_{Tot} [mW/g]

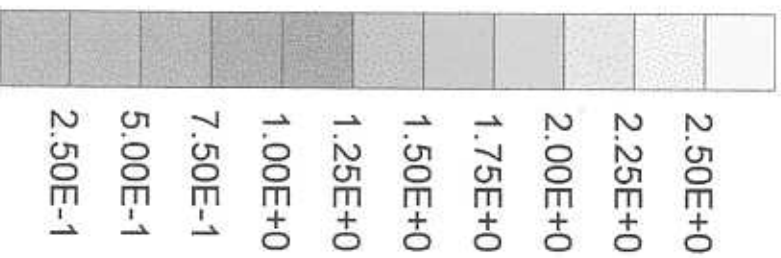

Y

PRM
De 1

Con
Avg
16

↑

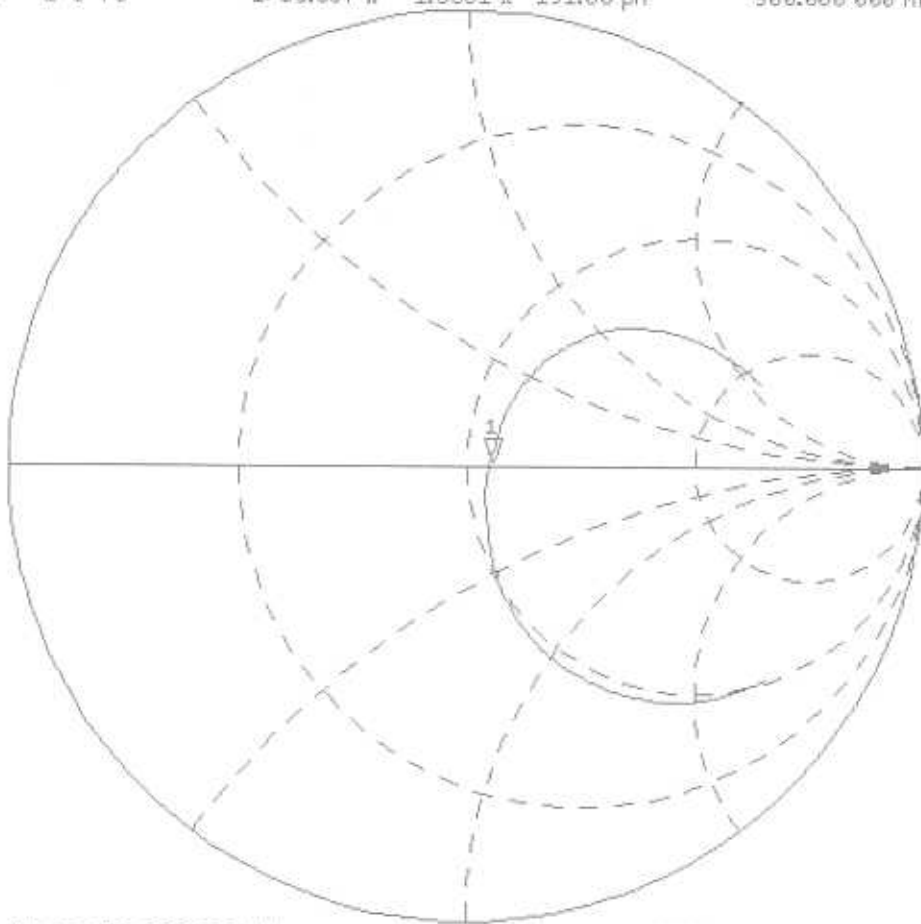

START 700.000 000 MHz

STOP 1 100.000 000 MHz

CHI S11 L06 5 dB/REF 0 dB 1:-25.555 dB 900.000 000 MHz

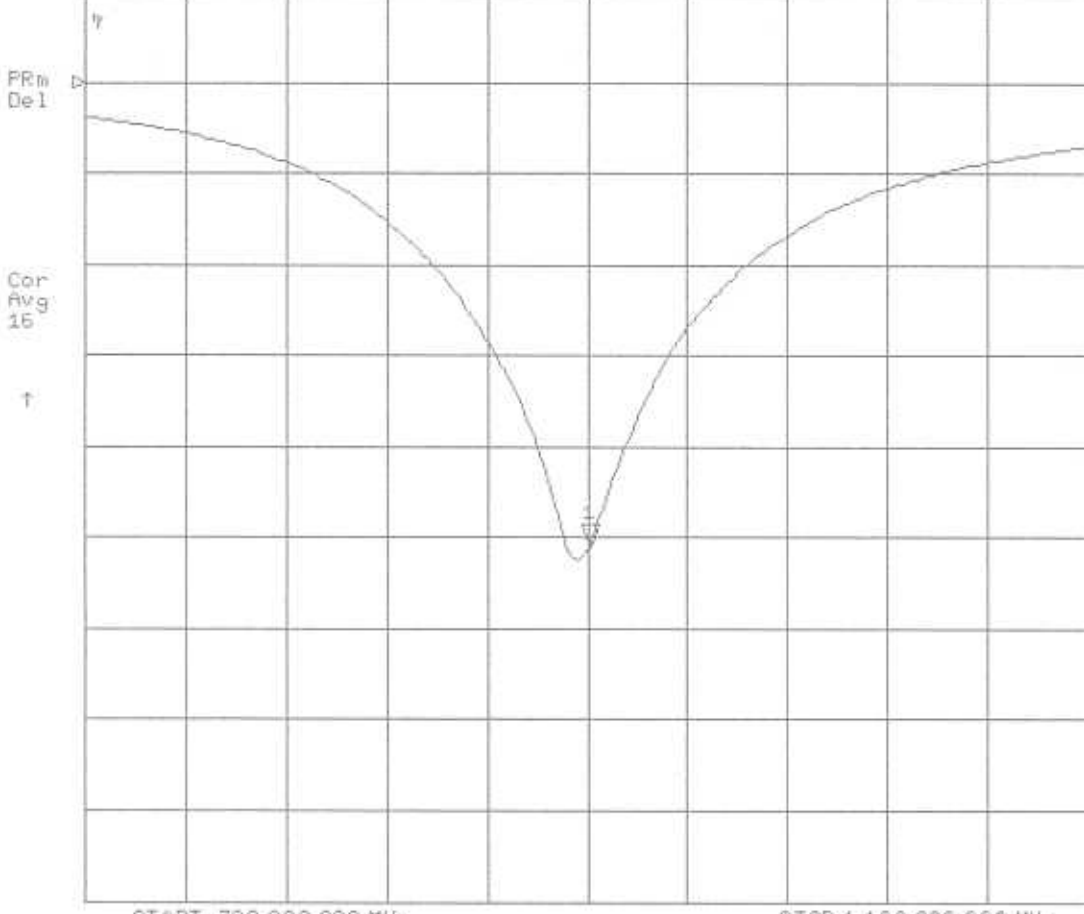

Calibration Certificate

1800 MHz System Validation Dipole

Type:

D1800V2

Serial Number:

294

Place of Calibration:

Zurich

Date of Calibration:

Apr. 19, 2001

Calibration Interval:

24 months

Schmid & Partner Engineering AG hereby certifies, that this device has been calibrated on the date indicated above. The calibration was performed in accordance with specifications and procedures of Schmid & Partner Engineering AG.

Wherever applicable, the standards used in the calibration process are traceable to international standards. In all other cases the standards of the Laboratory for EMF and Microwave Electronics at the Swiss Federal Institute of Technology (ETH) in Zurich, Switzerland have been applied.

Calibrated by:



Approved by:



1. Measurement Conditions

The measurements were performed in the flat section of the new generic twin phantom filled with head simulating sugar solution of the following electrical parameters at 1800 MHz:

Relative permittivity	39.7	$\pm 5\%$
Conductivity	1.36 mho/m	$\pm 10\%$

The DASY3 System (Software version 3.1c) with a dosimetric E-field probe ET3DV6 (SN:1507, conversion factor 5.57 at 1800 MHz) was used for the measurements.

The dipole feedpoint was positioned below the centre marking and oriented parallel to the body axis (the long side of the phantom). The standard measuring distance was 10mm from dipole centre to the solution surface. The included distance holder was used during measurements for accurate distance positioning.

The coarse grid with a grid spacing of 15mm was aligned with the dipole. The 5x5x7 fine cube was chosen for cube integration. Probe isotropy errors were cancelled by measuring the SAR with normal and 90° turned probe orientations and averaging. The dipole input power (forward power) was 250mW $\pm 3\%$. The results are normalised to 1W input power.

2. SAR Measurement

Standard SAR-measurements were performed with the head phantom according to the measurement conditions described in section 1. The results (see figure) have been normalised to a dipole input power of 1W (forward power). The resulting averaged SAR-values are:

averaged over 1 cm ³ (1 g) of tissue:	38.4 mW/g
averaged over 10 cm ³ (10 g) of tissue:	20.0 mW/g

Note: If the liquid parameters for validation are slightly different from the ones used for initial calibration, the SAR-values will be different as well. The estimated sensitivities of SAR-values and penetration depths to the liquid parameters are listed in the DASY Application Note 4: 'SAR Sensitivities'.

3. Dipole Impedance and Return Loss

The impedance was measured at the SMA-connector with a network analyser and numerically transformed to the dipole feedpoint. The transformation parameters from the SMA-connector to the dipole feedpoint are:

Electrical delay:	1.216 ns	(one direction)
Transmission factor:	0.997	(voltage transmission, one direction)

The dipole was positioned at the flat phantom sections according to section 1 and the distance holder was in place during impedance measurements.

Feedpoint impedance at 1800 MHz:	$\text{Re}\{Z\} = 51.8 \Omega$
	$\text{Im}\{Z\} = -2.8 \Omega$
Return Loss at 1800 MHz	-29.7 dB

4. Handling

The dipole is made of standard semirigid coaxial cable. The centre conductor of the feeding line is directly connected to the second arm of the dipole. The antenna is therefore short-circuited for DC-signals.

Do not apply excessive force to the dipole arms, because they might bend. If the dipole arms have to be bent back, take care to release stress to the soldered connections near the feedpoint; they might come off.

After prolonged use with 40W radiated power, only a slight warming of the dipole near the feedpoint can be measured.

Validation Dipole D1800V2 SN:294, $d = 10$ mm

Frequency: 1800 MHz; Antenna Input Power: 250 [mW]

Generic: Twin Phantom; Flat Section; Grid Spacing: $D_x = 15.0$, $D_y = 15.0$, $D_z = 10.0$

Probe: ET3DV6 - SN1507; ConvF(5.57,5.57,5.57) at 1800 MHz; IEEE1528 1800 MHz; $\sigma = 1.36$ mho/m $\epsilon_r = 39.7$ $\rho = 1.00$ g/cm³

Cubes (2): Peak: 18.0 mW/g ± 0.04 dB, SAR (1g): 9.59 mW/g ± 0.04 dB, SAR (10g): 4.99 mW/g ± 0.04 dB, (Worst-case extrapolation)

Penetration depth: 8.3 (7.7, 9.4) [mm]

Powerdrift: -0.04 dB

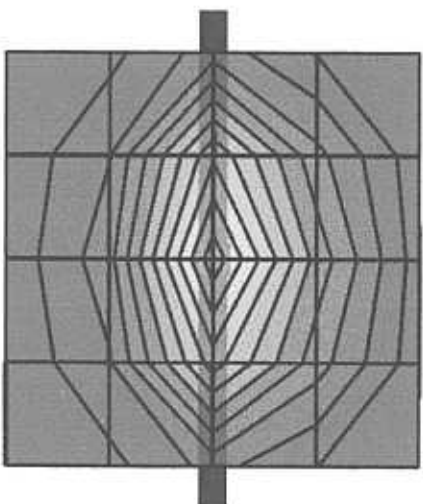

SAR_{Tot} [mW/g]

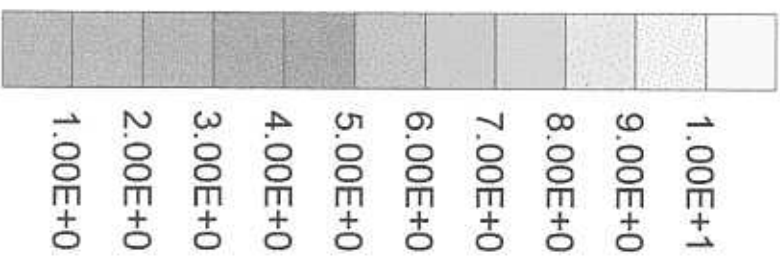

17 Apr 2001 15:51:27

CHI S11 1 U FS

1: 51.816 Δ -2.8066 Δ 31.504 pF

1 800.000 000 MHz

PRn
De 1

Cor
Avg
16

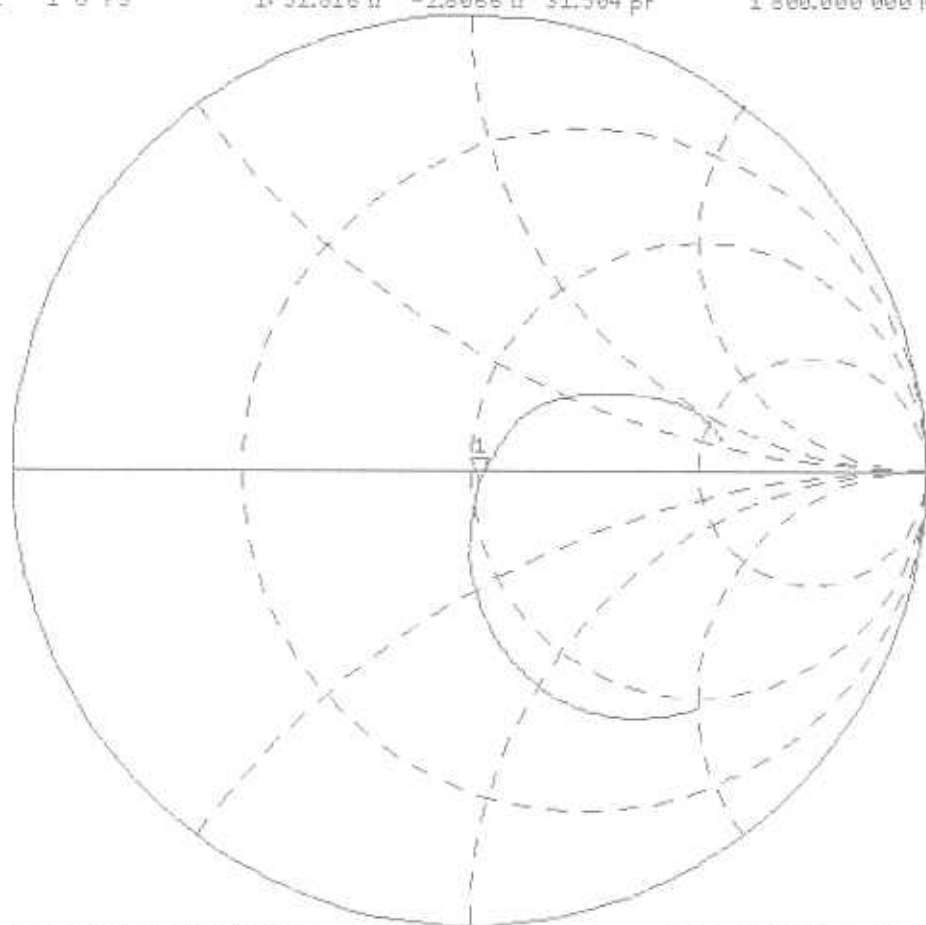

START 1 400.000 000 MHz

STOP 2 200.000 000 MHz

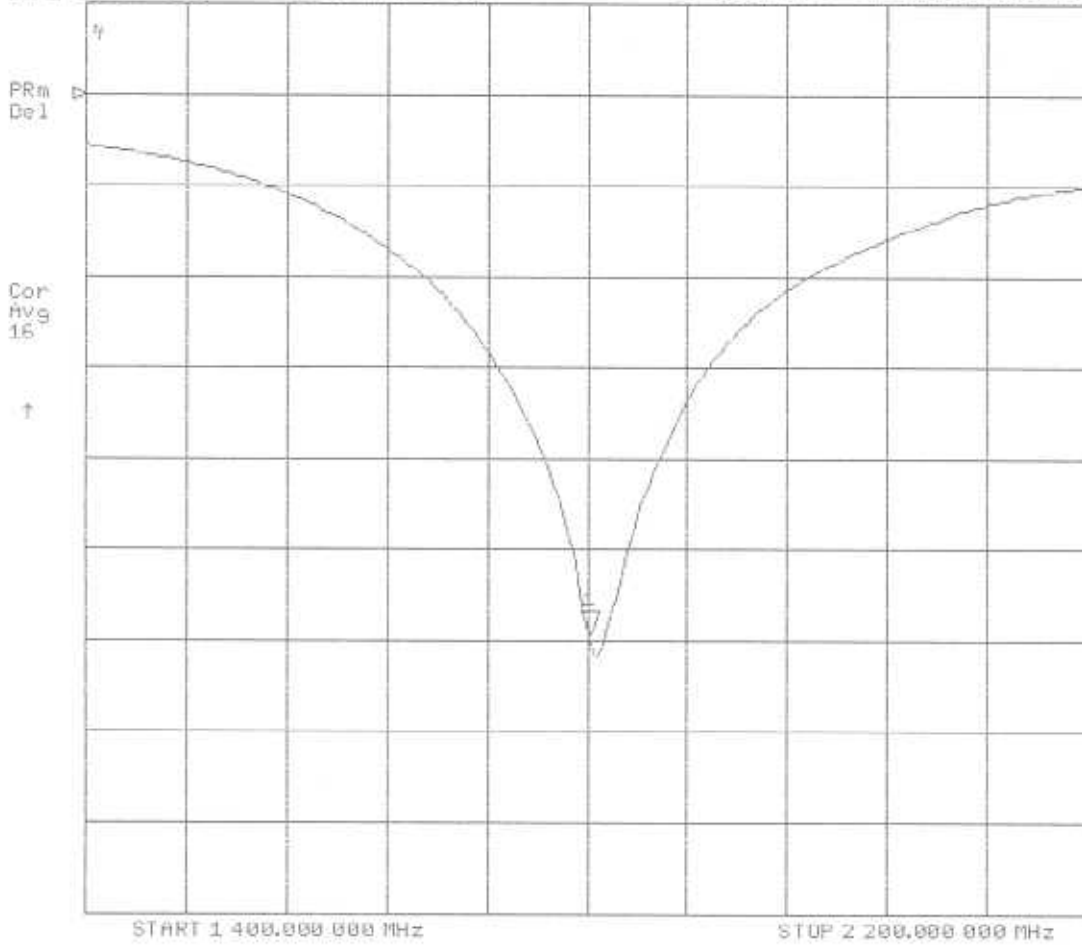

09/06/02

AirCard 555 With Laptop PC (Gateway); Frequency: 824.04 MHz

Frequency: 835 MHz; Crest factor: 1.0

Medium: Muscle 835 MHz: $\sigma = 0.93$ mho/m $\epsilon_r = 54.5$ $\rho = 1.00$ g/cm³

SAM-1 Phantom; Flat Section; Position: (90°,180°)

Probe: ET3DV6 - SN1578; ConvF(6.70,6.70,6.70);

SAR:Cube 5x5x7: Peak: 1.63 mW/g, SAR (1g): 1.08 mW/g, SAR (10g): 0.708 mW/g, (Worst-case extrapolation)

Penetration depth: 13.5 (12.3, 14.9) [mm]; Powerdrift: 0.01 dB

Coarse: Dx = 18.0, Dy = 19.0, Dz = 0.0

Ambient Temperature (degree C): 23

Liquid Temperature (degree C): 21.2

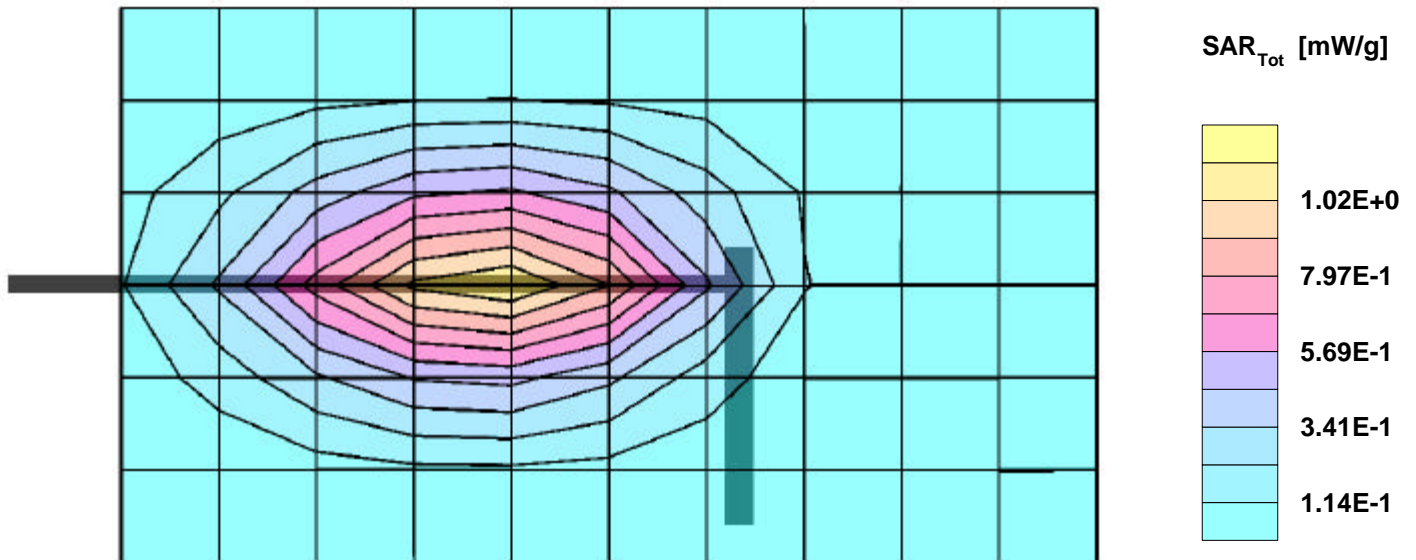

09/06/02

AirCard 555 With Laptop PC (Gateway); Frequency: 824.04 MHz

Frequency: 835 MHz; Crest factor: 1.0

Medium: Muscle 835 MHz: $\sigma = 0.93$ mho/m $\epsilon_r = 54.5$ $\rho = 1.00$ g/cm³

SAM-1 Phantom; Section; Position:

Probe: ET3DV6 - SN1578; ConvF(6.70,6.70,6.70);

SAR: , , ()

Penetration depth: 13.5 (12.2, 15.1) [mm];

Z-Axis: Dx = 0.0, Dy = 0.0, Dz = 2.0

Ambient Temperature (degree C): 23

Liquid Temperature (degree C): 21.2

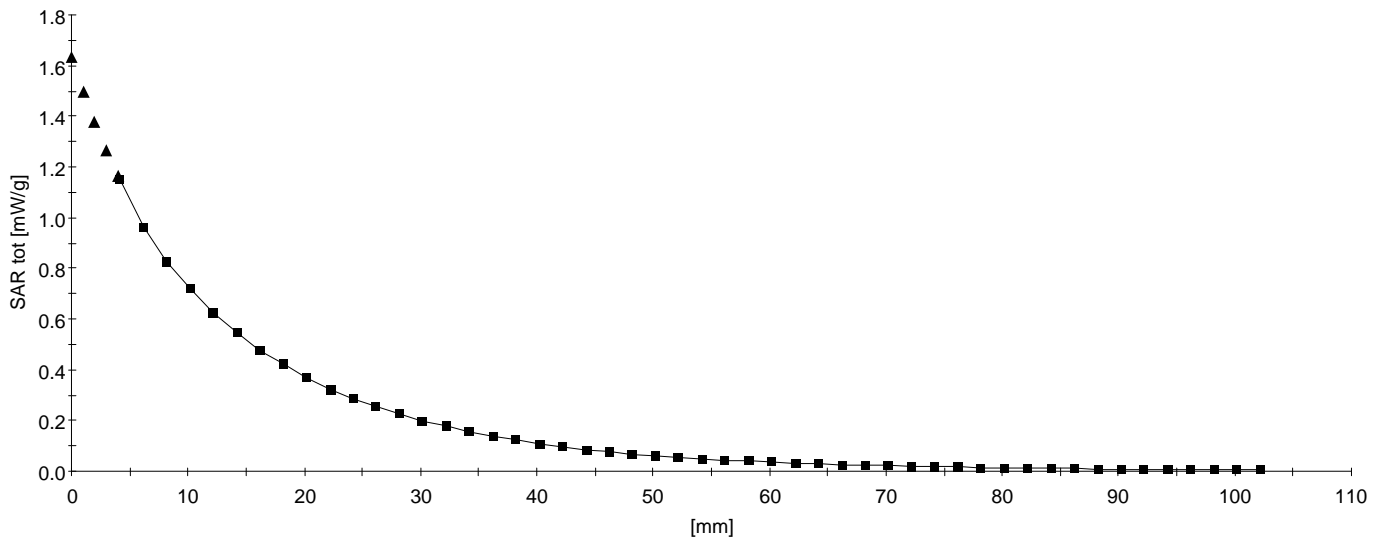

09/06/02

AirCard 555 With Laptop PC (Gateway); Frequency: 836.52 MHz

Frequency: 835 MHz; Crest factor: 1.0

Medium: Muscle 835 MHz: $\sigma = 0.93$ mho/m $\epsilon_r = 54.5$ $\rho = 1.00$ g/cm³

SAM-1 Phantom; Flat Section; Position: (90°,180°)

Probe: ET3DV6 - SN1578; ConvF(6.70,6.70,6.70);

SAR:Cube 5x5x7: Peak: 1.01 mW/g, SAR (1g): 0.668 mW/g, SAR (10g): 0.439 mW/g, (Worst-case extrapolation)

Penetration depth: 13.3 (12.1, 14.9) [mm]; Powerdrift: -0.00 dB

Coarse: Dx = 18.0, Dy = 19.0, Dz = 0.0

Ambient Temperature (degree C): 23

Liquid Temperature (degree C): 21.3

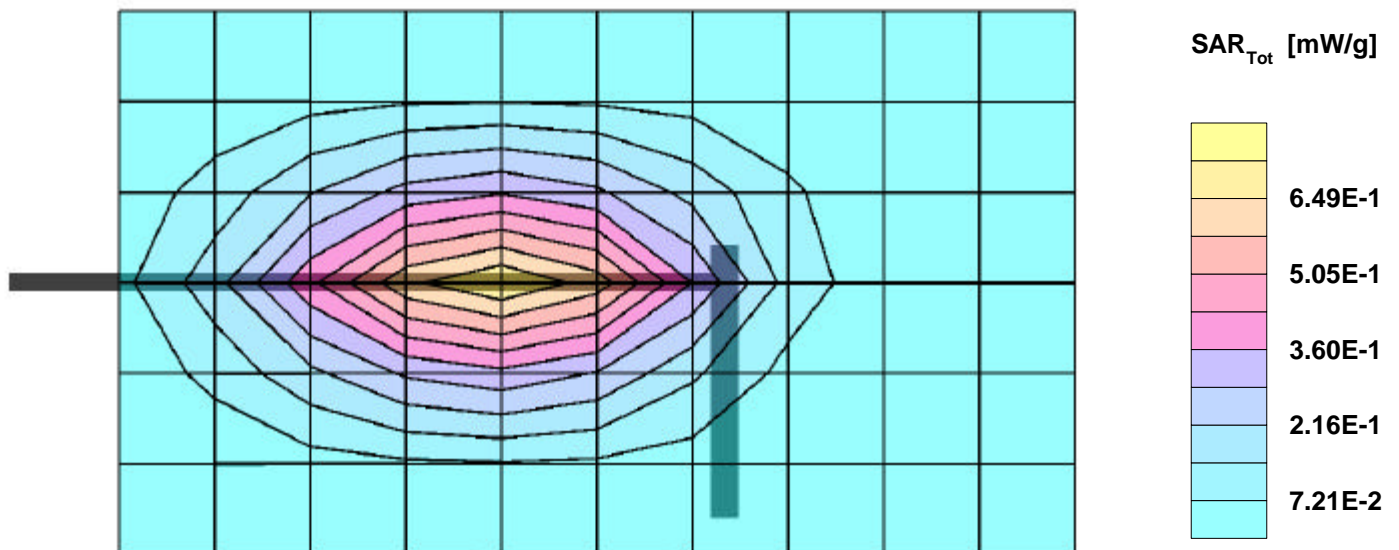

09/06/02

AirCard 555 With Laptop PC (Gateway); Frequency: 836.52 MHz

Frequency: 835 MHz; Crest factor: 1.0

Medium: Muscle 835 MHz: $\sigma = 0.93$ mho/m $\epsilon_r = 54.5$ $\rho = 1.00$ g/cm³

SAM-1 Phantom; Section; Position:

Probe: ET3DV6 - SN1578; ConvF(6.70,6.70,6.70);

SAR: , , ()

Penetration depth: 13.4 (12.2, 14.9) [mm];

Z-Axis: Dx = 0.0, Dy = 0.0, Dz = 2.0

Ambient Temperature (degree C): 23

Liquid Temperature (degree C): 21.3

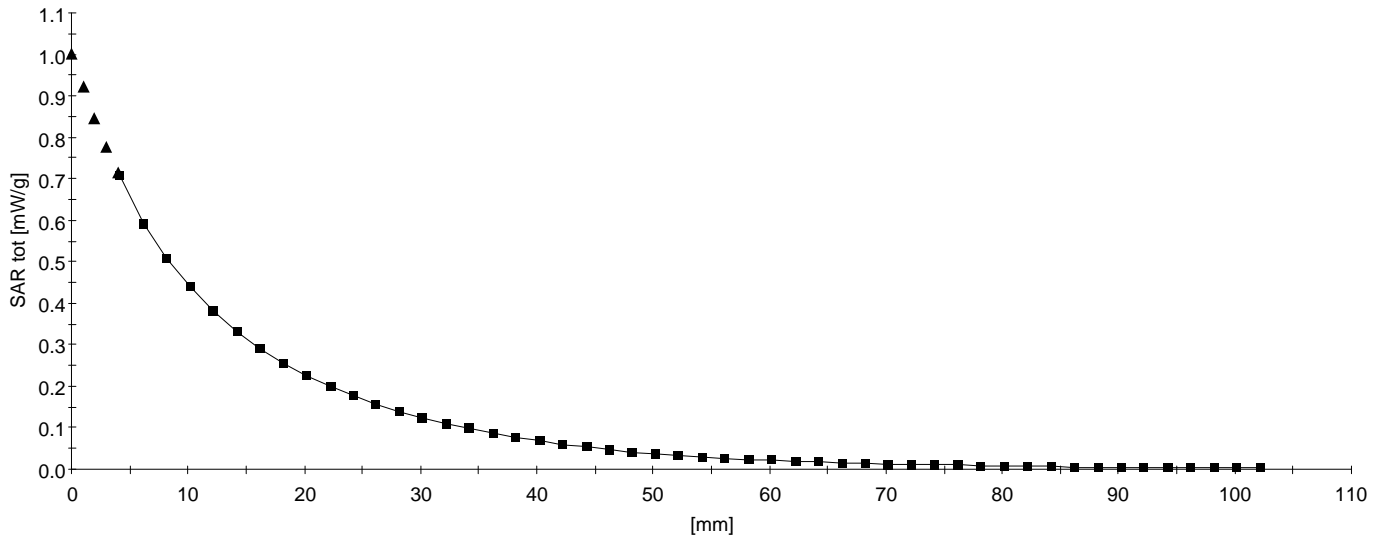

09/06/02

AirCard 555 With Laptop PC (Gateway); Frequency: 848.97 MHz

Frequency: 835 MHz; Crest factor: 1.0

Medium: Muscle 835 MHz: $\sigma = 0.93$ mho/m $\epsilon_r = 54.5$ $\rho = 1.00$ g/cm³

SAM-1 Phantom; Flat Section; Position: (90°,180°)

Probe: ET3DV6 - SN1578; ConvF(6.70,6.70,6.70);

SAR:Cube 5x5x7: Peak: 1.59 mW/g, SAR (1g): 1.05 mW/g, SAR (10g): 0.687 mW/g, (Worst-case extrapolation)

Penetration depth: 13.4 (12.1, 14.9) [mm]; Powerdrift: -0.06 dB

Coarse: Dx = 18.0, Dy = 19.0, Dz = 0.0

Ambient Temperature (degree C): 23

Liquid Temperature (degree C): 21.1

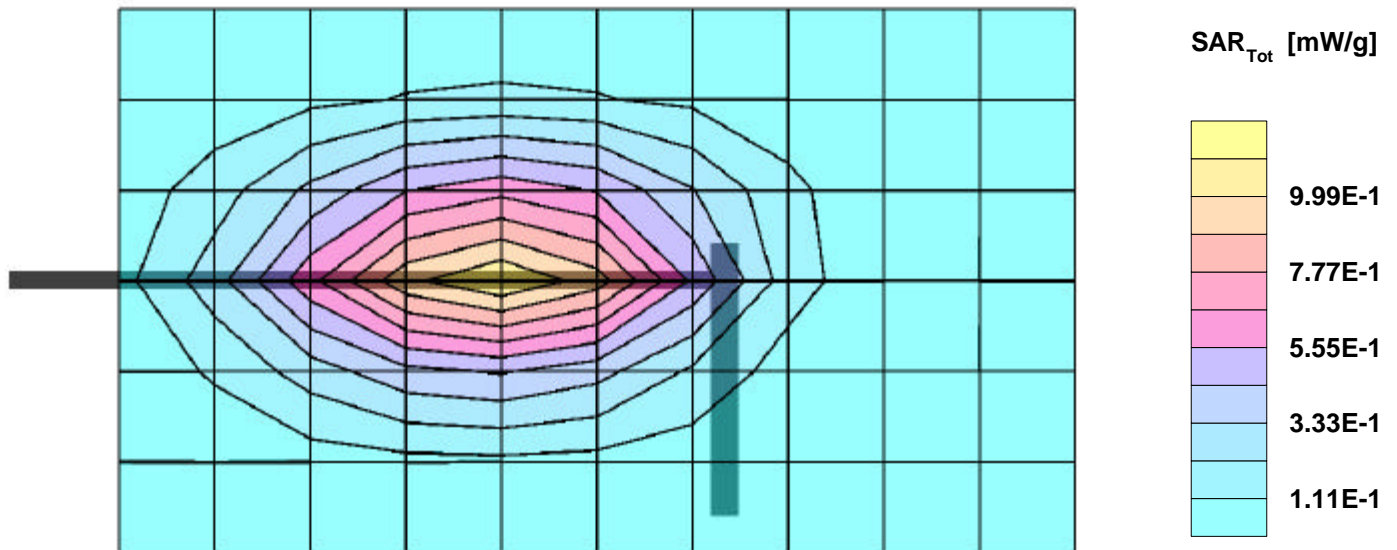

09/06/02

AirCard 555 With Laptop PC (Gateway); Frequency: 848.97 MHz

Frequency: 835 MHz; Crest factor: 1.0

Medium: Muscle 835 MHz: $\sigma = 0.93$ mho/m $\epsilon_r = 54.5$ $\rho = 1.00$ g/cm³

SAM-1 Phantom; Section; Position:

Probe: ET3DV6 - SN1578; ConvF(6.70,6.70,6.70);

SAR: , , ()

Penetration depth: 13.4 (12.1, 14.9) [mm];

Z-Axis: Dx = 0.0, Dy = 0.0, Dz = 2.0

Ambient Temperature (degree C): 23

Liquid Temperature (degree C): 21.1

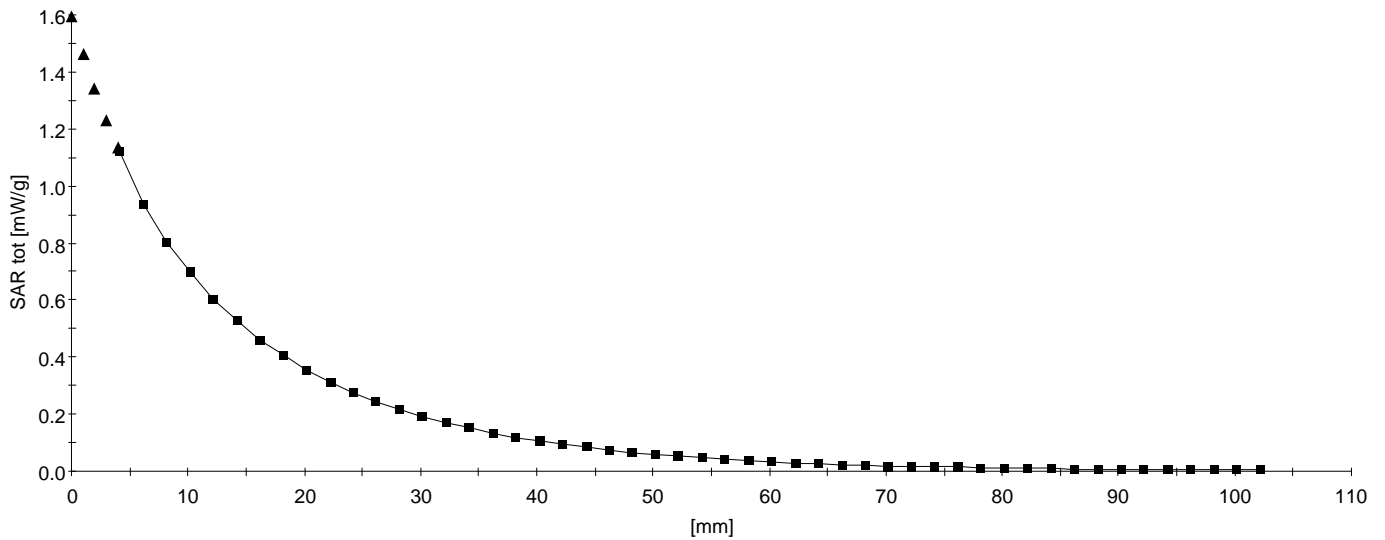

09/06/02

AirCard 555 With Laptop PC (Gateway); Frequency: 824.04 MHz

Frequency: 835 MHz; Crest factor: 1.0

Medium: Muscle 835 MHz: $\sigma = 0.93$ mho/m $\epsilon_r = 54.5$ $\rho = 1.00$ g/cm³

SAM-1 Phantom; Flat Section; Position: (270°, 90°)

Probe: ET3DV6 - SN1578; ConvF(6.70,6.70,6.70);

SAR: Cube 5x5x7: Peak: 0.119 mW/g, SAR (1g): 0.0805 mW/g, SAR (10g): 0.0536 mW/g, (Worst-case extrapolation)

Penetration depth: 14.9 (14.4, 15.4) [mm]; Powerdrift: Measurement value below zero

Coarse: Dx = 18.0, Dy = 19.0, Dz = 0.0

Ambient Temperature (degree C): 23

Liquid Temperature (degree C): 21.2

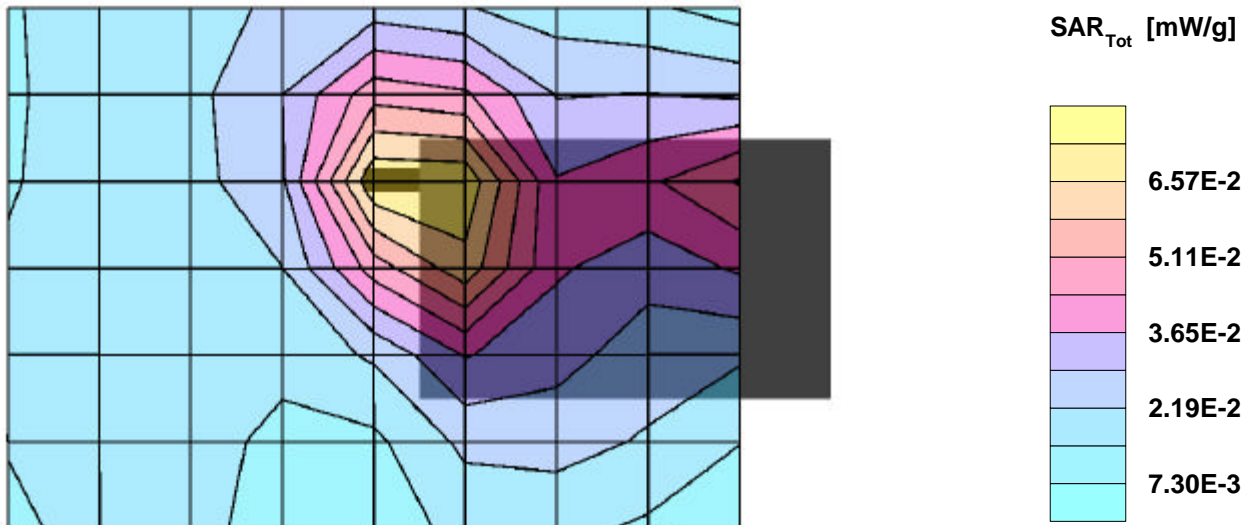

09/06/02

AirCard 555 With Laptop PC (Gateway); Frequency: 824.04 MHz

Frequency: 835 MHz; Crest factor: 1.0

Medium: Muscle 835 MHz: $\sigma = 0.93 \text{ mho/m}$ $\epsilon_r = 54.5$ $\rho = 1.00 \text{ g/cm}^3$

SAM-1 Phantom; Section; Position:

Probe: ET3DV6 - SN1578; ConvF(6.70,6.70,6.70);

SAR: , , ()

Penetration depth: 15.4 (14.2, 16.5) [mm];

Z-Axis: $D_x = 0.0$, $D_y = 0.0$, $D_z = 2.0$

Ambient Temperature (degree C): 23

Liquid Temperature (degree C): 21.2

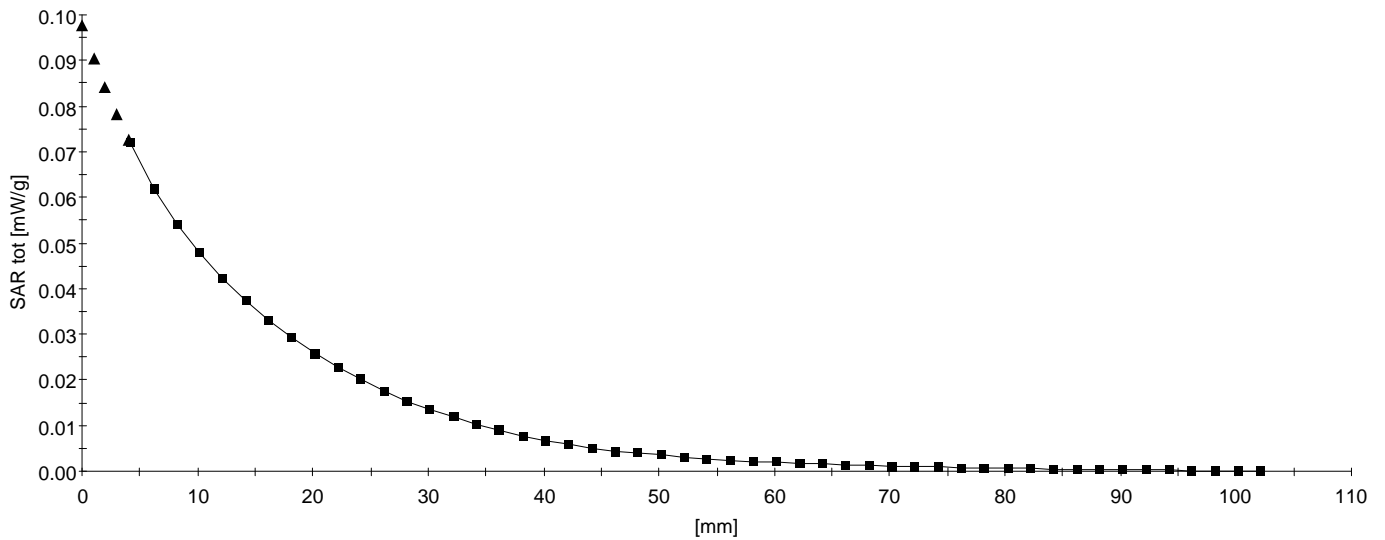

09/06/02

AirCard 555 With Laptop PC (Gateway); Frequency: 836.52 MHz

Frequency: 835 MHz; Crest factor: 1.0

Medium: Muscle 835 MHz: $\sigma = 0.93$ mho/m $\epsilon_r = 54.5$ $\rho = 1.00$ g/cm³

SAM-1 Phantom; Flat Section; Position: (270°, 90°)

Probe: ET3DV6 - SN1578; ConvF(6.70,6.70,6.70);

SAR: Cube 5x5x7: Peak: 0.0598 mW/g, SAR (1g): 0.0393 mW/g, SAR (10g): 0.0264 mW/g, (Worst-case extrapolation)

Penetration depth: 14.3 (14.0, 14.6) [mm]; Powerdrift: 0.02 dB

Coarse: Dx = 18.0, Dy = 19.0, Dz = 0.0

Ambient Temperature (degree C): 23

Liquid Temperature (degree C): 21.1

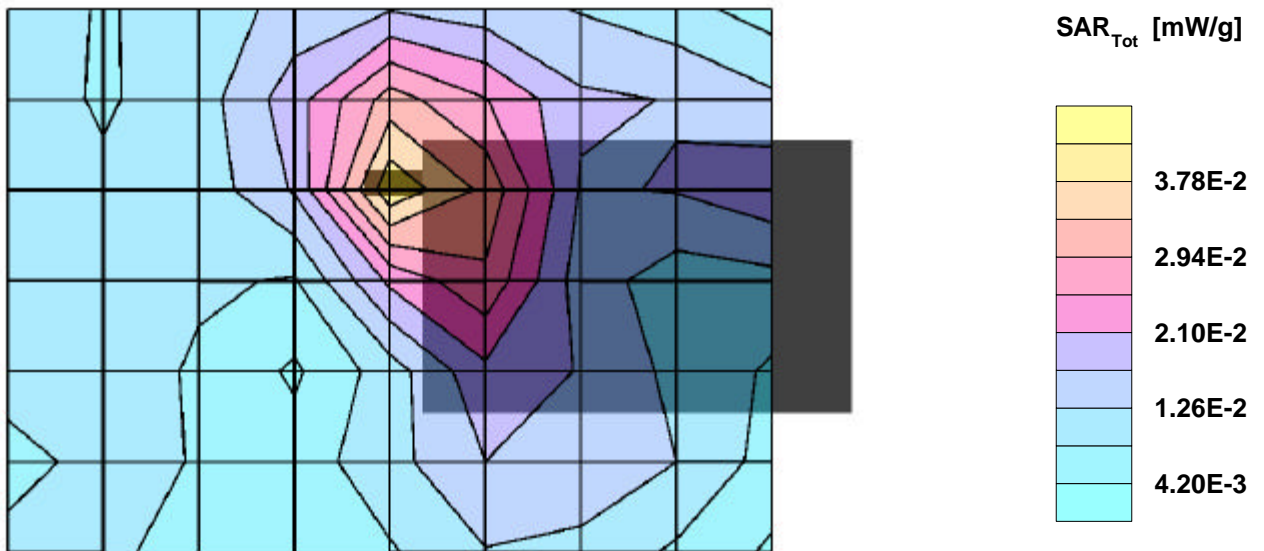

09/06/02

AirCard 555 With Laptop PC (Gateway); Frequency: 836.52 MHz

Frequency: 835 MHz; Crest factor: 1.0

Medium: Muscle 835 MHz: $\sigma = 0.93 \text{ mho/m}$ $\epsilon_r = 54.5$ $\rho = 1.00 \text{ g/cm}^3$

SAM-1 Phantom; Section; Position:

Probe: ET3DV6 - SN1578; ConvF(6.70,6.70,6.70);

SAR: , , ()

Penetration depth: 13.5 (11.9, 15.3) [mm];

Z-Axis: $D_x = 0.0$, $D_y = 0.0$, $D_z = 2.0$

Ambient Temperature (degree C): 23

Liquid Temperature (degree C): 21.1

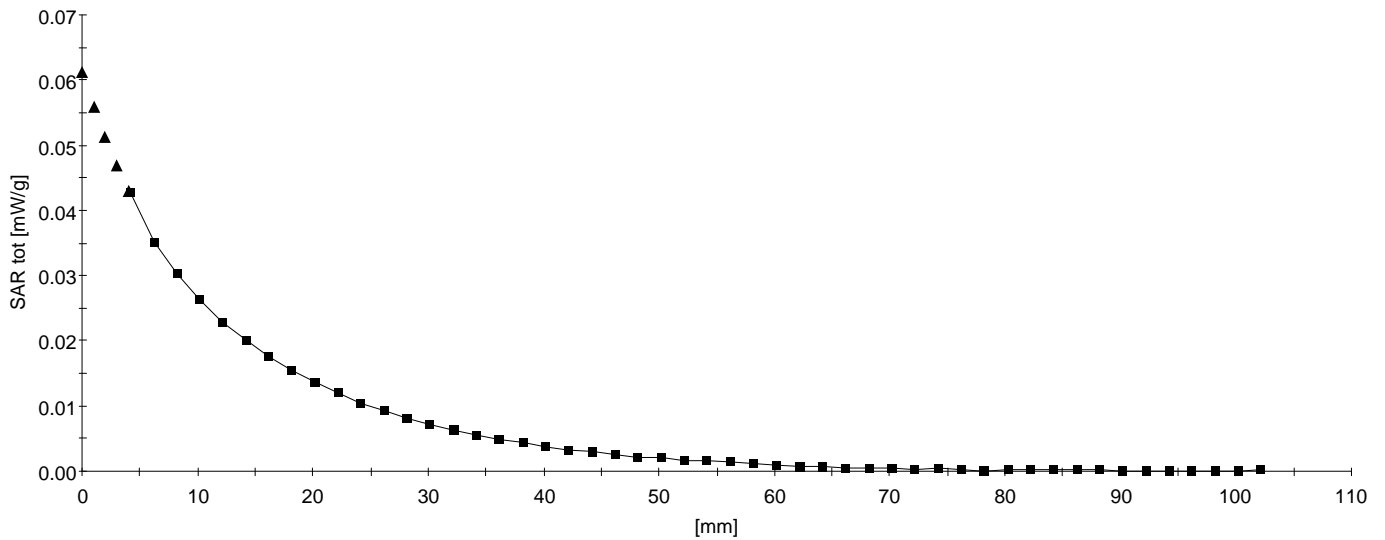

09/06/02

AirCard 555 With Laptop PC (Gateway); Frequency: 848.97 MHz

Frequency: 835 MHz; Crest factor: 1.0

Medium: Muscle 835 MHz: $\sigma = 0.93$ mho/m $\epsilon_r = 54.5$ $\rho = 1.00$ g/cm³

SAM-1 Phantom; Flat Section; Position: (270°, 90°)

Probe: ET3DV6 - SN1578; ConvF(6.70,6.70,6.70);

SAR:Cube 5x5x7: Peak: 0.0514 mW/g, SAR (1g): 0.0341 mW/g, SAR (10g): 0.0227 mW/g, (Worst-case extrapolation)

Penetration depth: 15.7 (15.7, 15.8) [mm]; Powerdrift: -0.02 dB

Coarse: Dx = 18.0, Dy = 19.0, Dz = 0.0

Ambient Temperature (degree C): 23

Liquid Temperature (degree C): 21.0

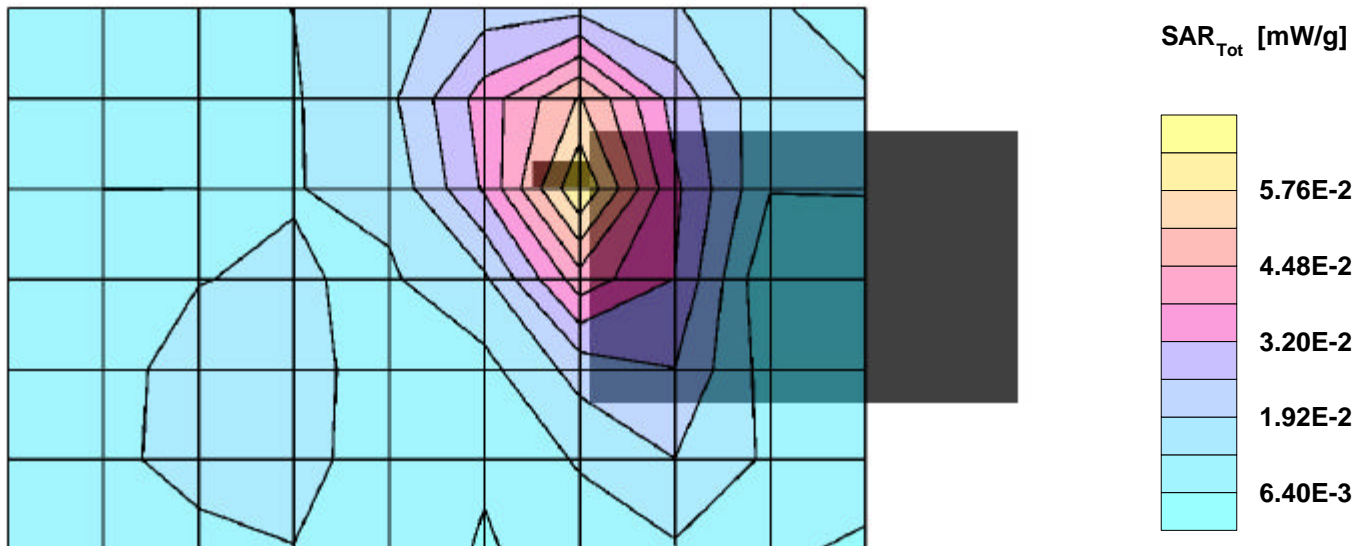

09/06/02

AirCard 555 With Laptop PC (Gateway); Frequency: 848.97 MHz

Frequency: 835 MHz; Crest factor: 1.0

Medium: Muscle 835 MHz: $\sigma = 0.93$ mho/m $\epsilon_r = 54.5$ $\rho = 1.00$ g/cm³

SAM-1 Phantom; Section; Position:

Probe: ET3DV6 - SN1578; ConvF(6.70,6.70,6.70);

SAR: , , ()

Penetration depth: 14.3 (13.3, 15.4) [mm];

Z-Axis: Dx = 0.0, Dy = 0.0, Dz = 2.0

Ambient Temperature (degree C): 23

Liquid Temperature (degree C): 21.0

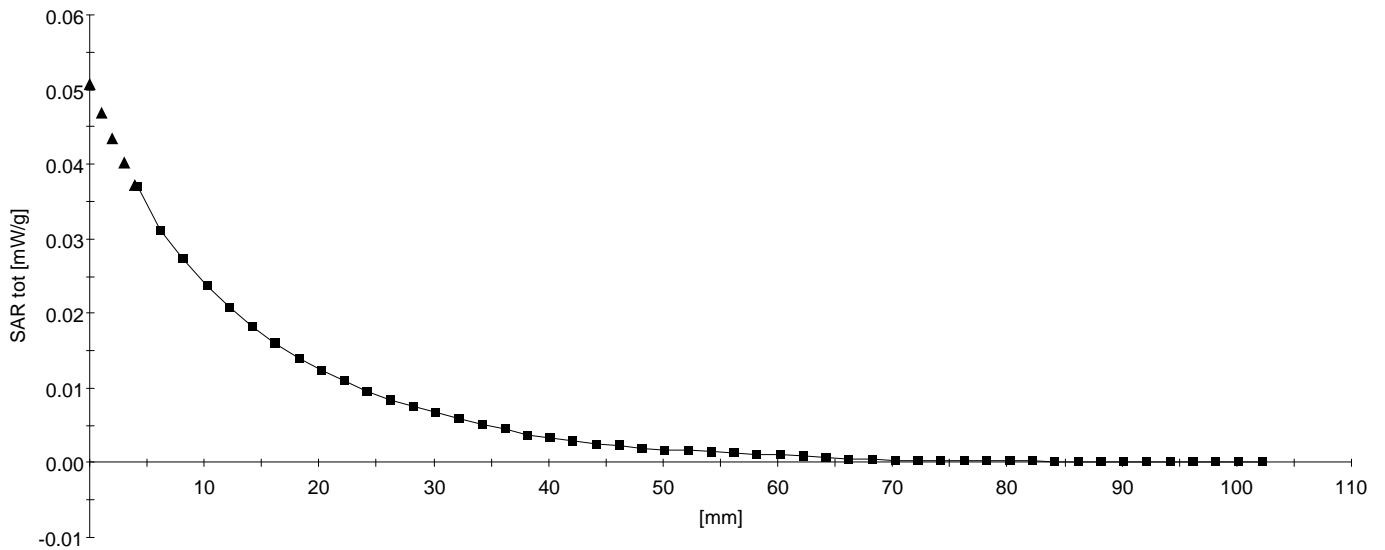

09/06/02

AirCard 555 With Laptop PC (Gateway); Frequency: 824.04 MHz

Frequency: 835 MHz; Crest factor: 1.0

Medium: Muscle 835 MHz: $\sigma = 0.93$ mho/m $\epsilon_r = 54.5$ $\rho = 1.00$ g/cm³

SAM-1 Phantom; Flat Section; Position: (270°,90°)

Probe: ET3DV6 - SN1578; ConvF(6.70,6.70,6.70);

SAR:Cube 5x5x7: Peak: 0.357 mW/g, SAR (1g): 0.256 mW/g, SAR (10g): 0.183 mW/g, (Worst-case extrapolation)

Penetration depth: 16.2 (14.9, 17.6) [mm]; Powerdrift: -0.05 dB

Coarse: Dx = 18.0, Dy = 19.0, Dz = 0.0

Ambient Temperature (degree C): 23

Liquid Temperature (degree C): 21.0

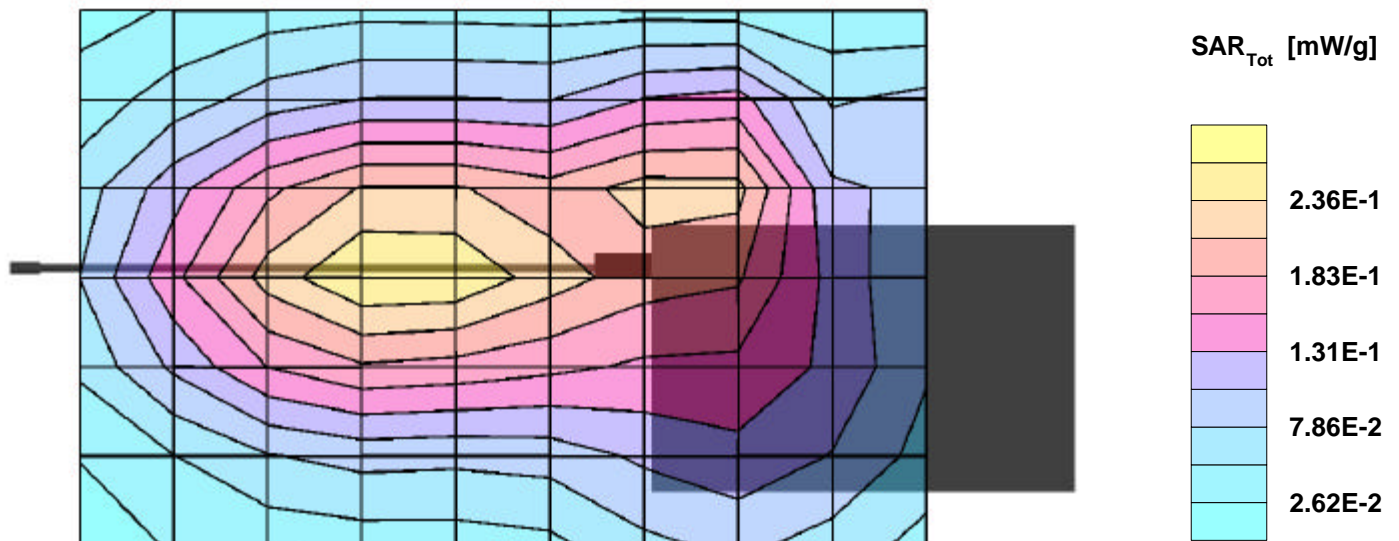

09/06/02

AirCard 555 With Laptop PC (Gateway); Frequency: 824.04 MHz

Frequency: 835 MHz; Crest factor: 1.0

Medium: Muscle 835 MHz: $\sigma = 0.93$ mho/m $\epsilon_r = 54.5$ $\rho = 1.00$ g/cm³

SAM-1 Phantom; Section; Position:

Probe: ET3DV6 - SN1578; ConvF(6.70,6.70,6.70);

SAR: , , ()

Penetration depth: 16.4 (15.0, 17.8) [mm];

Z-Axis: Dx = 0.0, Dy = 0.0, Dz = 2.0

Ambient Temperature (degree C): 23

Liquid Temperature (degree C): 21.0

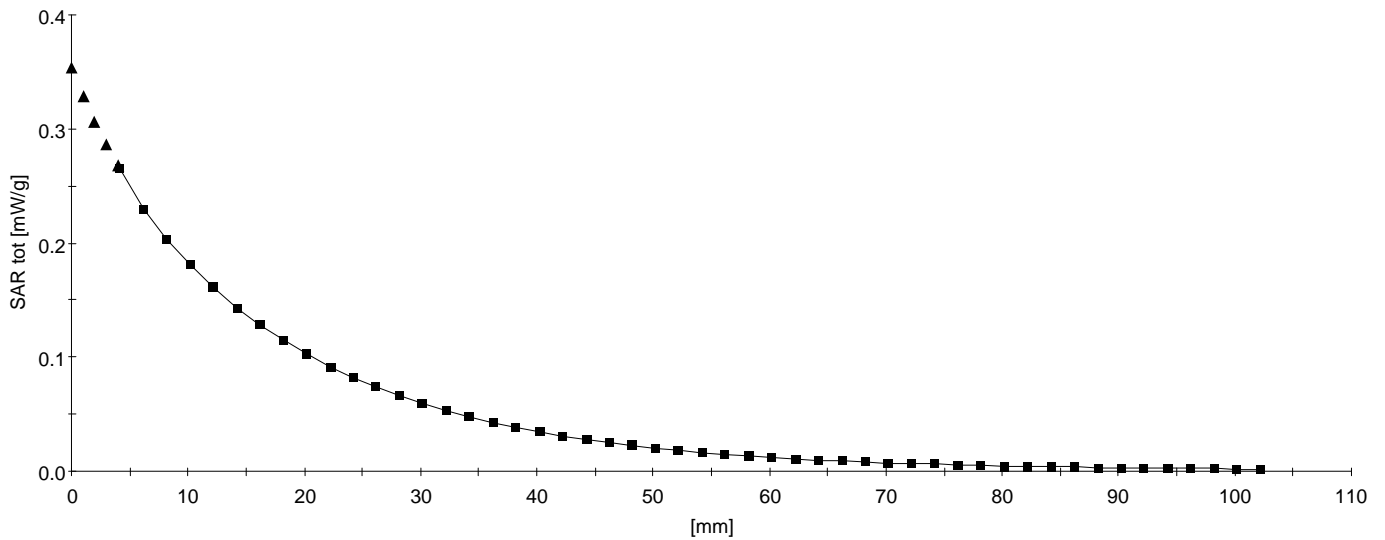

09/06/02

AirCard 555 With Laptop PC (Gateway); Frequency: 836.52 MHz

Frequency: 835 MHz; Crest factor: 1.0

Medium: Muscle 835 MHz: $\sigma = 0.93$ mho/m $\epsilon_r = 54.5$ $\rho = 1.00$ g/cm³

SAM-1 Phantom; Flat Section; Position: (270°, 90°)

Probe: ET3DV6 - SN1578; ConvF(6.70,6.70,6.70);

SAR:Cube 5x5x7: Peak: 0.237 mW/g, SAR (1g): 0.169 mW/g, SAR (10g): 0.122 mW/g, (Worst-case extrapolation)

Penetration depth: 16.3 (14.9, 17.9) [mm]; Powerdrift: -0.14 dB

Coarse: Dx = 18.0, Dy = 19.0, Dz = 0.0

Ambient Temperature (degree C): 23

Liquid Temperature (degree C): 21.1

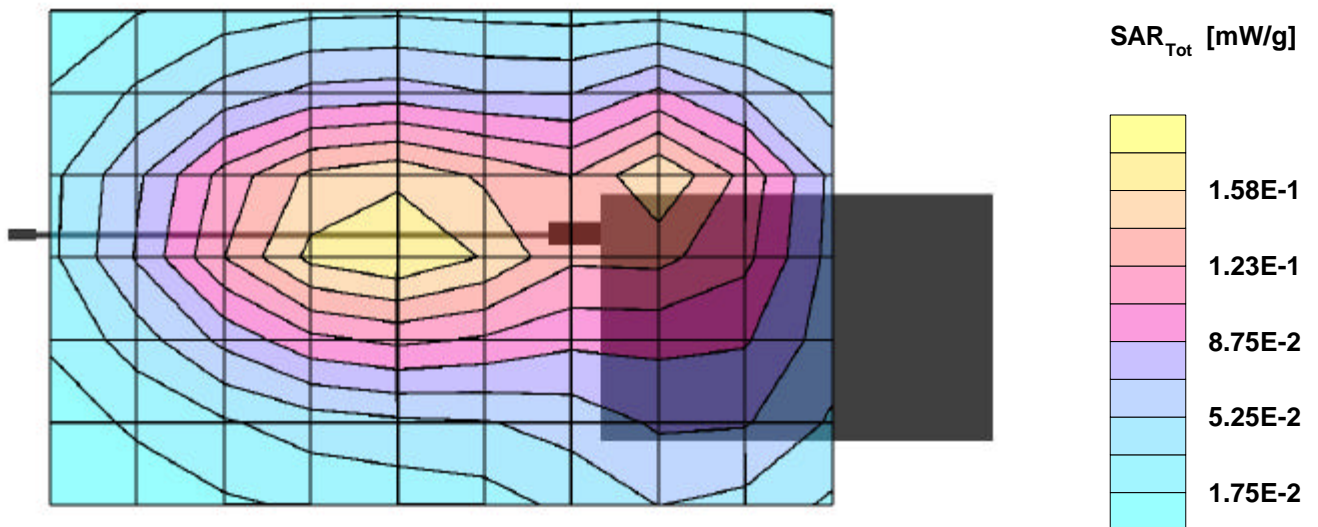

09/06/02

AirCard 555 With Laptop PC (Gateway); Frequency: 836.52 MHz

Frequency: 835 MHz; Crest factor: 1.0

Medium: Muscle 835 MHz: $\sigma = 0.93 \text{ mho/m}$ $\epsilon_r = 54.5$ $\rho = 1.00 \text{ g/cm}^3$

SAM-1 Phantom; Section; Position:

Probe: ET3DV6 - SN1578; ConvF(6.70,6.70,6.70);

SAR: , , ()

Penetration depth: 16.5 (15.0, 18.1) [mm];

Z-Axis: $D_x = 0.0$, $D_y = 0.0$, $D_z = 2.0$

Ambient Temperature (degree C): 23

Liquid Temperature (degree C): 21.1

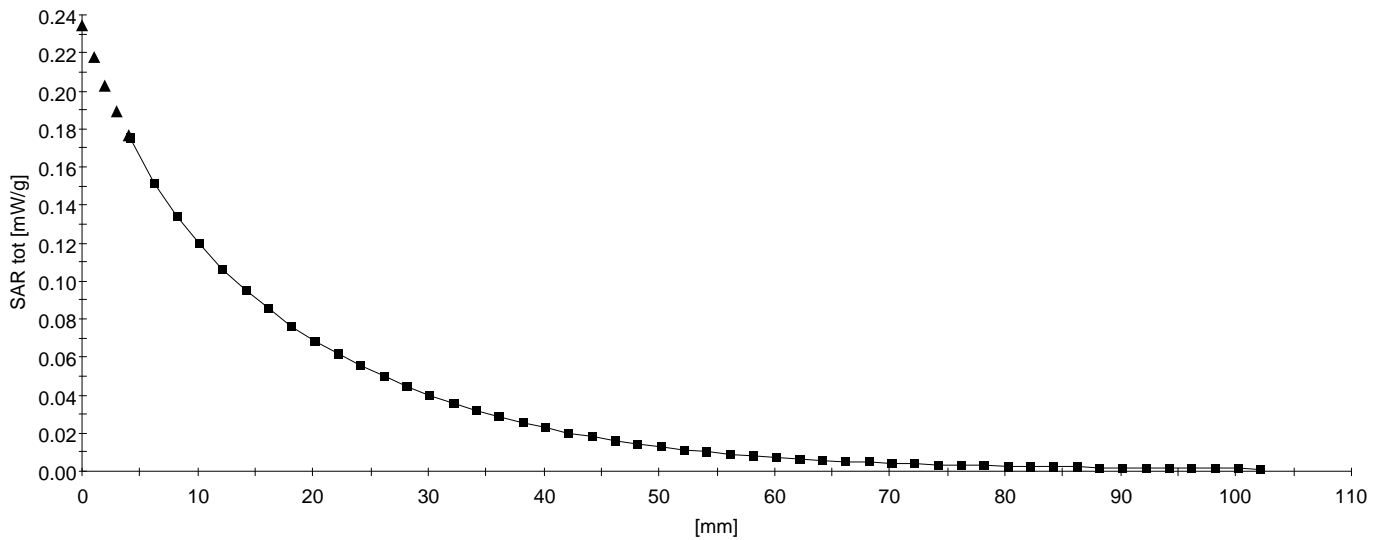

09/06/02

AirCard 555 With Laptop PC (Gateway); Frequency: 848.97 MHz

Frequency: 835 MHz; Crest factor: 1.0

Medium: Muscle 835 MHz: $\sigma = 0.93$ mho/m $\epsilon_r = 54.5$ $\rho = 1.00$ g/cm³

SAM-1 Phantom; Flat Section; Position: (270°, 90°)

Probe: ET3DV6 - SN1578; ConvF(6.70,6.70,6.70);

SAR:Cube 5x5x7: Peak: 0.356 mW/g, SAR (1g): 0.254 mW/g, SAR (10g): 0.182 mW/g, (Worst-case extrapolation)

Penetration depth: 16.2 (14.8, 17.7) [mm]; Powerdrift: -0.02 dB

Coarse: Dx = 18.0, Dy = 19.0, Dz = 0.0

Ambient Temperature (degree C): 23

Liquid Temperature (degree C): 21.1

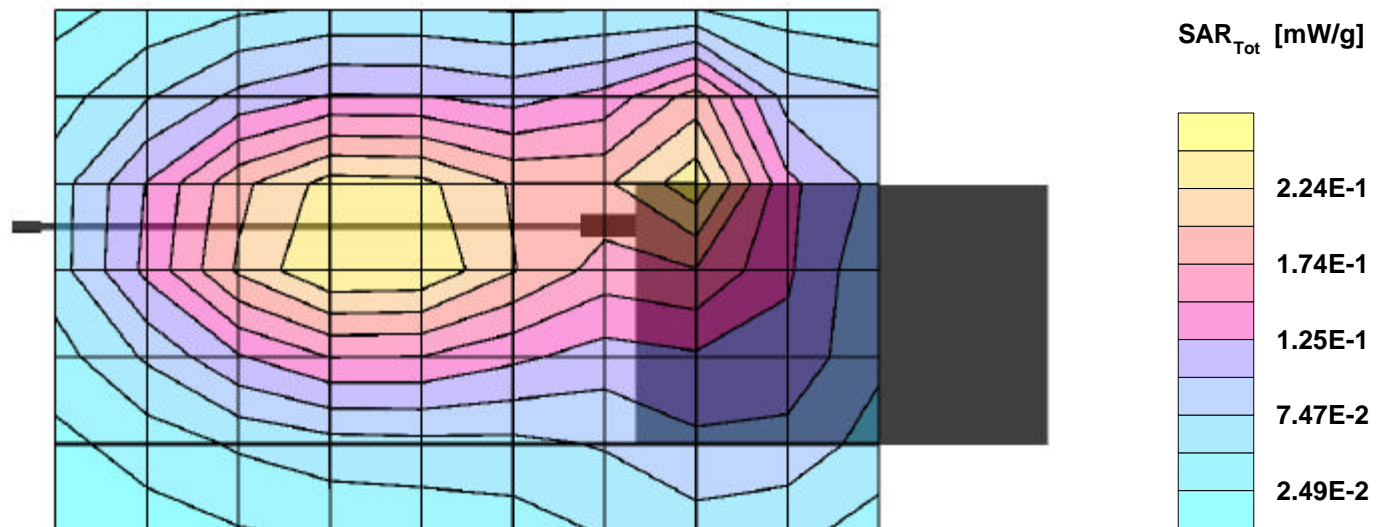

09/06/02

AirCard 555 With Laptop PC (Gateway); Frequency: 848.97 MHz

Frequency: 835 MHz; Crest factor: 1.0

Medium: Muscle 835 MHz: $\sigma = 0.93$ mho/m $\epsilon_r = 54.5$ $\rho = 1.00$ g/cm³

SAM-1 Phantom; Section; Position:

Probe: ET3DV6 - SN1578; ConvF(6.70,6.70,6.70);

SAR: , , ()

Penetration depth: 16.3 (14.9, 17.8) [mm];

Z-Axis: Dx = 0.0, Dy = 0.0, Dz = 2.0

Ambient Temperature (degree C): 23

Liquid Temperature (degree C): 21.1

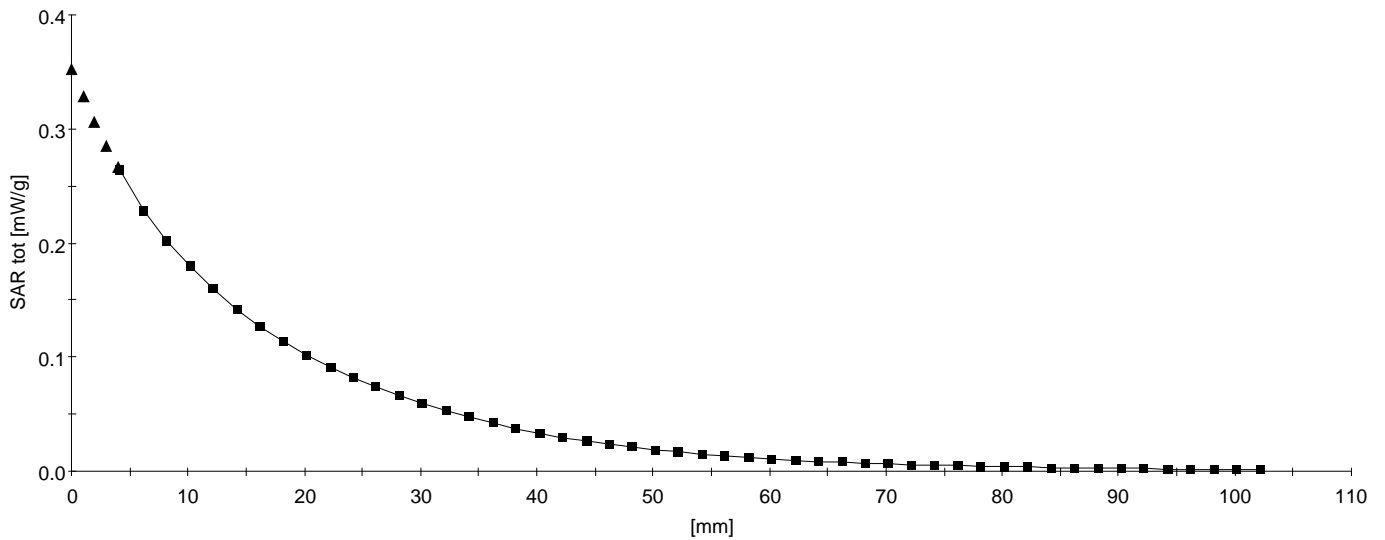

09/06/02

AirCard 555 With Laptop PC (Gateway); Frequency: 824.04 MHz

Frequency: 835 MHz; Crest factor: 1.0

Medium: Muscle 835 MHz: $\sigma = 0.93$ mho/m $\epsilon_r = 54.5$ $\rho = 1.00$ g/cm³

SAM-1 Phantom; Flat Section; Position: (270°,180°)

Probe: ET3DV6 - SN1578; ConvF(6.70,6.70,6.70);

SAR:Cube 5x5x7: Peak: 1.67 mW/g, SAR (1g): 1.08 mW/g, SAR (10g): 0.706 mW/g, (Worst-case extrapolation)

Penetration depth: 13.0 (11.8, 14.6) [mm]; Powerdrift: -0.13 dB

Coarse: Dx = 18.0, Dy = 19.0, Dz = 0.0

Ambient Temperature (degree C): 23

Liquid Temperature (degree C): 22.3

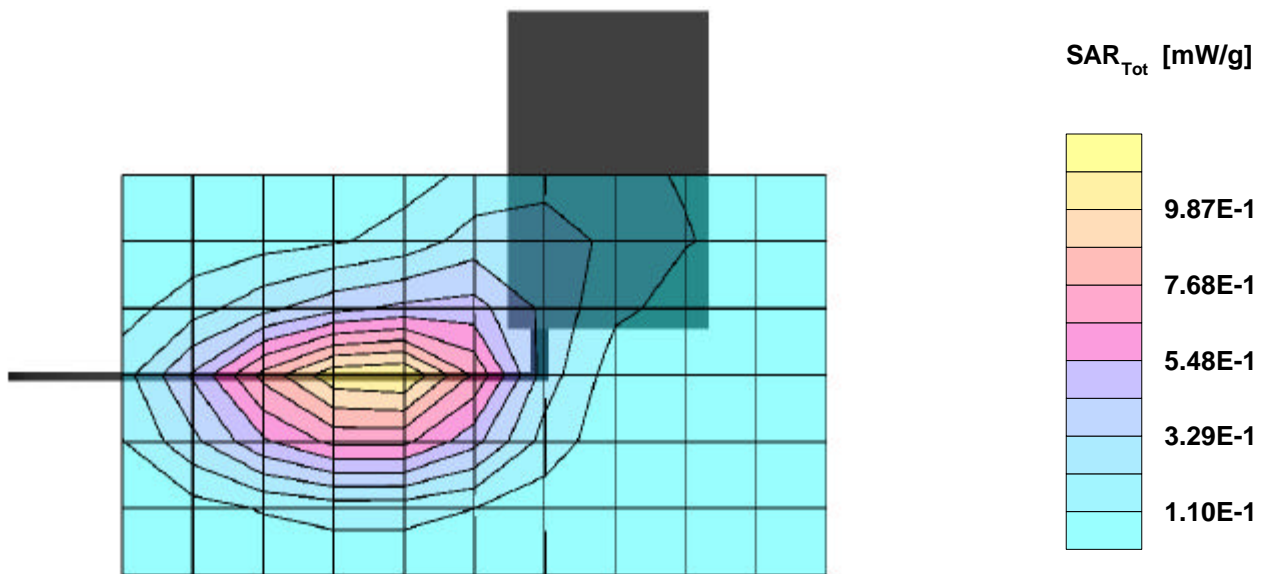

09/06/02

AirCard 555 With Laptop PC (Gateway); Frequency: 824.04 MHz

Frequency: 835 MHz; Crest factor: 1.0

Medium: Muscle 835 MHz: $\sigma = 0.93$ mho/m $\epsilon_r = 54.5$ $\rho = 1.00$ g/cm³

SAM-1 Phantom; Section; Position:

Probe: ET3DV6 - SN1578; ConvF(6.70,6.70,6.70);

SAR: , , ()

Penetration depth: 13.0 (11.6, 14.7) [mm];

Z-Axis: Dx = 0.0, Dy = 0.0, Dz = 2.0

Ambient Temperature (degree C): 23

Liquid Temperature (degree C): 22.3

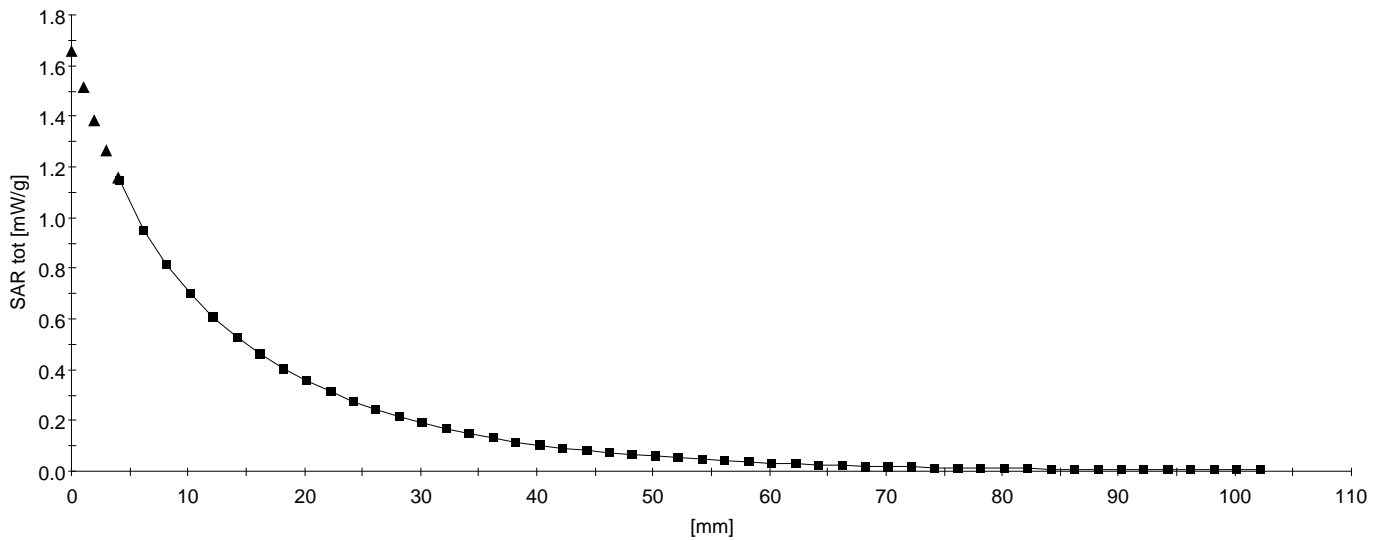

09/06/02

AirCard 555 With Laptop PC (Gateway); Frequency: 836.52 MHz

Frequency: 835 MHz; Crest factor: 1.0

Medium: Muscle 835 MHz: $\sigma = 0.93$ mho/m $\epsilon_r = 54.5$ $\rho = 1.00$ g/cm³

SAM-1 Phantom; Flat Section; Position: (270°,180°)

Probe: ET3DV6 - SN1578; ConvF(6.70,6.70,6.70);

SAR:Cube 5x5x7: Peak: 1.28 mW/g, SAR (1g): 0.821 mW/g, SAR (10g): 0.530 mW/g, (Worst-case extrapolation)

Penetration depth: 12.7 (11.3, 14.4) [mm]; Powerdrift: 0.00 dB

Coarse: Dx = 18.0, Dy = 19.0, Dz = 0.0

Ambient Temperature (degree C): 23

Liquid Temperature (degree C): 21.9

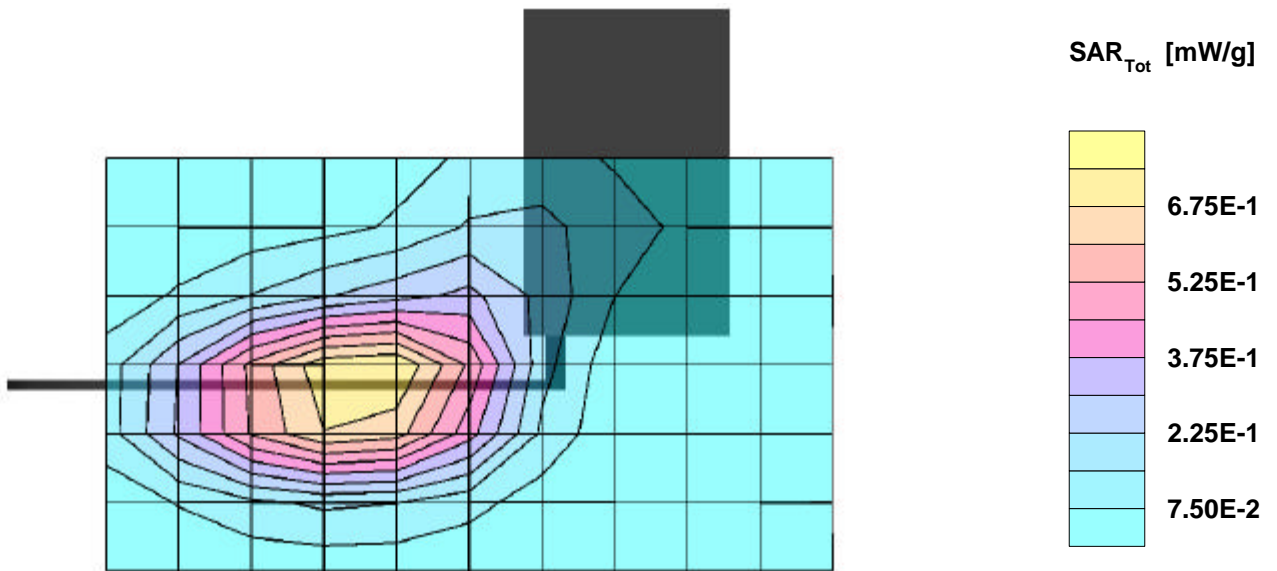

09/06/02

AirCard 555 With Laptop PC (Gateway); Frequency: 836.52 MHz

Frequency: 835 MHz; Crest factor: 1.0

Medium: Muscle 835 MHz: $\sigma = 0.93$ mho/m $\epsilon_r = 54.5$ $\rho = 1.00$ g/cm³

SAM-1 Phantom; Section; Position:

Probe: ET3DV6 - SN1578; ConvF(6.70,6.70,6.70);

SAR: , , ()

Penetration depth: 12.8 (11.4, 14.5) [mm];

Z-Axis: Dx = 0.0, Dy = 0.0, Dz = 2.0

Ambient Temperature (degree C): 23

Liquid Temperature (degree C): 21.9

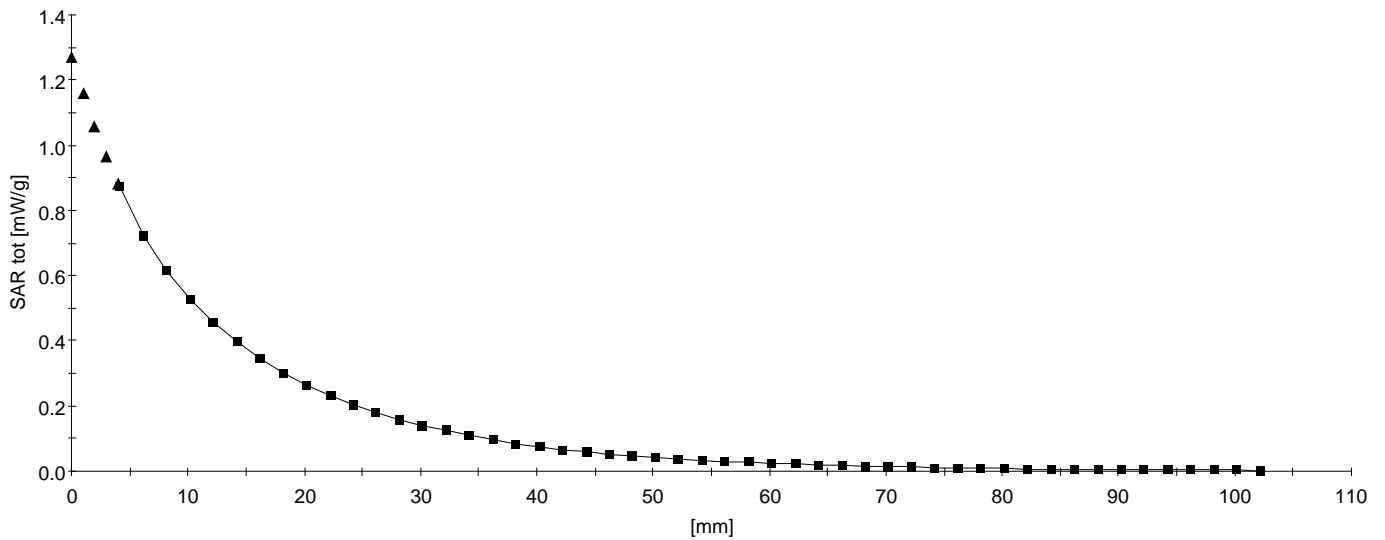

09/06/02

AirCard 555 With Laptop PC (Gateway); Frequency: 848.97 MHz

Frequency: 835 MHz; Crest factor: 1.0

Medium: Muscle 835 MHz: $s = 0.93$ mho/m $\epsilon_r = 54.5$ $\rho = 1.00$ g/cm³

SAM-1 Phantom; Flat Section; Position: (270°,180°)

Probe: ET3DV6 - SN1578; ConvF(6.70,6.70,6.70);

SAR:Cube 5x5x7: Peak: 1.74 mW/g, SAR (1g): 1.11 mW/g, SAR (10g): 0.715 mW/g, (Worst-case extrapolation)

Penetration depth: 12.4 (11.2, 14.1) [mm]; Powerdrift: 0.01 dB

Coarse: Dx = 18.0, Dy = 19.0, Dz = 0.0

Ambient Temperature (degree C): 23

Liquid Temperature (degree C): 22.0

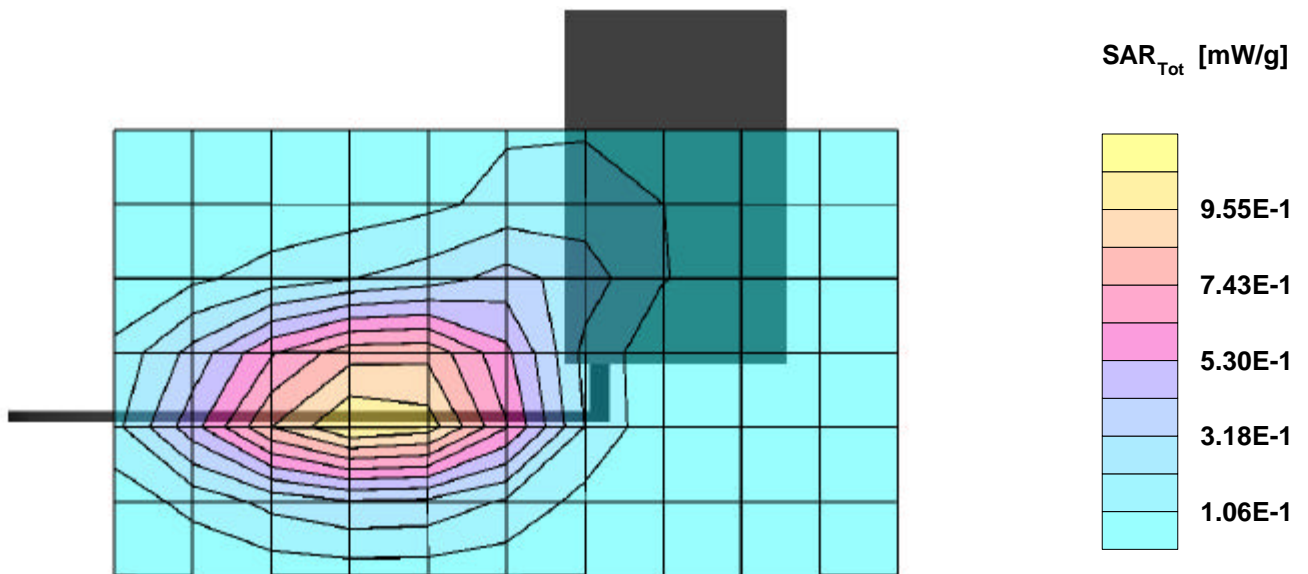

09/06/02

AirCard 555 With Laptop PC (Gateway); Frequency: 848.97 MHz

Frequency: 835 MHz; Crest factor: 1.0

Medium: Muscle 835 MHz: $\sigma = 0.93$ mho/m $\epsilon_r = 54.5$ $\rho = 1.00$ g/cm³

SAM-1 Phantom; Section; Position:

Probe: ET3DV6 - SN1578; ConvF(6.70,6.70,6.70);

SAR: , , ()

Penetration depth: 12.5 (11.2, 14.1) [mm];

Z-Axis: Dx = 0.0, Dy = 0.0, Dz = 2.0

Ambient Temperature (degree C): 23

Liquid Temperature (degree C): 22.0

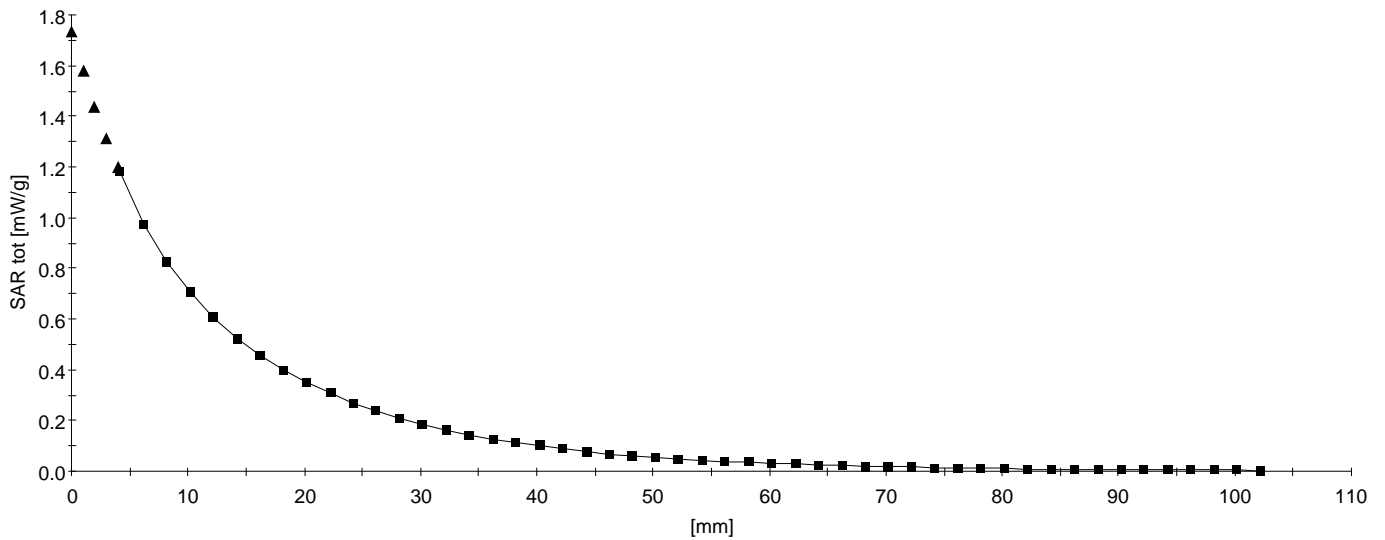

09/07/02

AirCard 555 With Laptop PC (Gateway); Frequency: 1850 MHz

Frequency: 1900 MHz; Crest factor: 1.0

Medium: Muscle 1900 MHz: $s = 1.45$ mho/m $\epsilon_r = 52.0$ $\rho = 1.00$ g/cm³

SAM-1 Phantom; Flat Section; Position: (90°,180°)

Probe: ET3DV6 - SN1578; ConvF(5.10,5.10,5.10);

SAR:Cube 5x5x7: Peak: 1.17 mW/g, SAR (1g): 0.676 mW/g, SAR (10g): 0.378 mW/g, (Worst-case extrapolation)

Penetration depth: 10.3 (9.2, 11.9) [mm]; Powerdrift: 0.09 dB

Coarse: Dx = 18.0, Dy = 19.0, Dz = 0.0

Ambient Temperature (degree C): 23

Liquid Temperature (degree C): 21.9

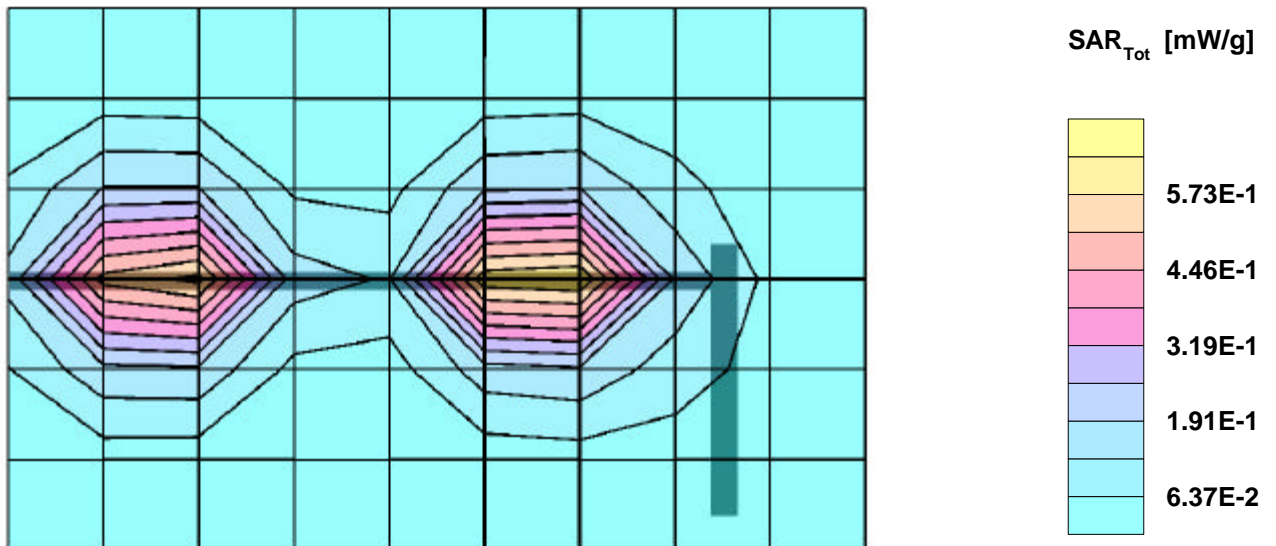

09/07/02

AirCard 555 With Laptop PC (Gateway); Frequency: 1850 MHz

Frequency: 1900 MHz; Crest factor: 1.0

Medium: Muscle 1900 MHz: $s = 1.45$ mho/m $\epsilon_r = 52.0$ $\rho = 1.00$ g/cm³

SAM-1 Phantom; Section; Position:

Probe: ET3DV6 - SN1578; ConvF(5.10,5.10,5.10);

SAR: , , ()

Penetration depth: 10.3 (9.3, 11.8) [mm];

Z-Axis: $D_x = 0.0$, $D_y = 0.0$, $D_z = 2.0$

Ambient Temperature (degree C): 23

Liquid Temperature (degree C): 21.9

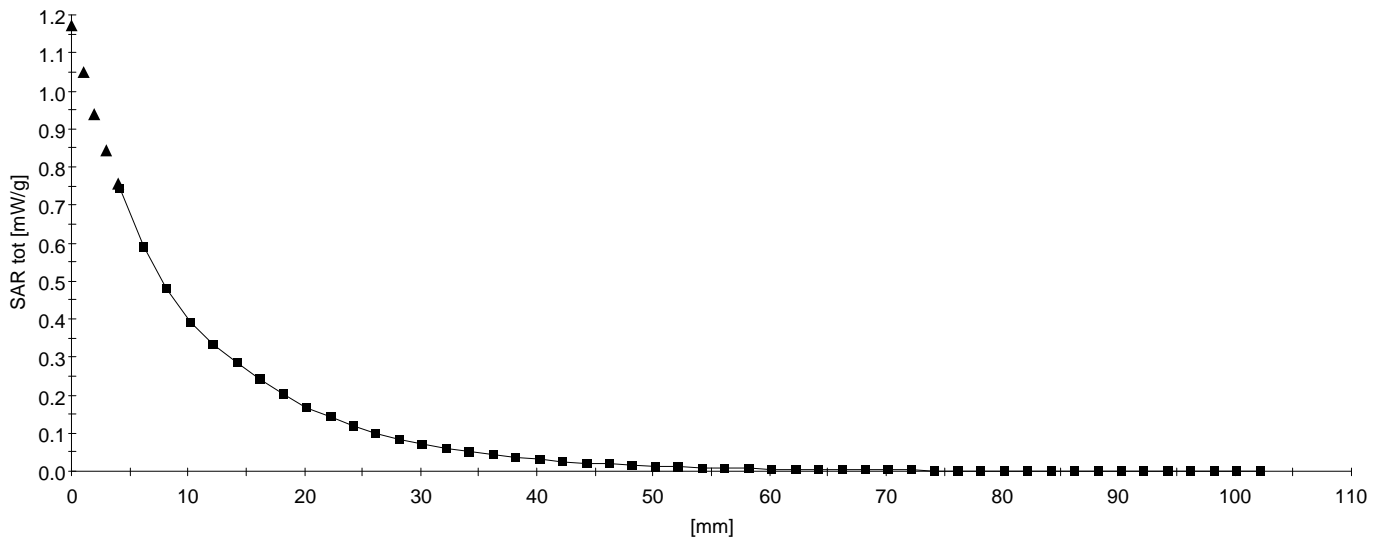

09/07/02

AirCard 555 With Laptop PC (Gateway); Frequency: 1880 MHz

Frequency: 1900 MHz; Crest factor: 1.0

Medium: Muscle 1900 MHz: $s = 1.45$ mho/m $\epsilon_r = 52.0$ $\rho = 1.00$ g/cm³

SAM-1 Phantom; Flat Section; Position: (90°,180°)

Probe: ET3DV6 - SN1578; ConvF(5.10,5.10,5.10);

SAR:Cube 5x5x7: Peak: 1.37 mW/g, SAR (1g): 0.781 mW/g, SAR (10g): 0.434 mW/g, (Worst-case extrapolation)

Penetration depth: 10.0 (9.0, 11.5) [mm]; Powerdrift: -0.01 dB

Coarse: Dx = 18.0, Dy = 19.0, Dz = 0.0

Ambient Temperature (degree C): 23

Liquid Temperature (degree C): 22.0

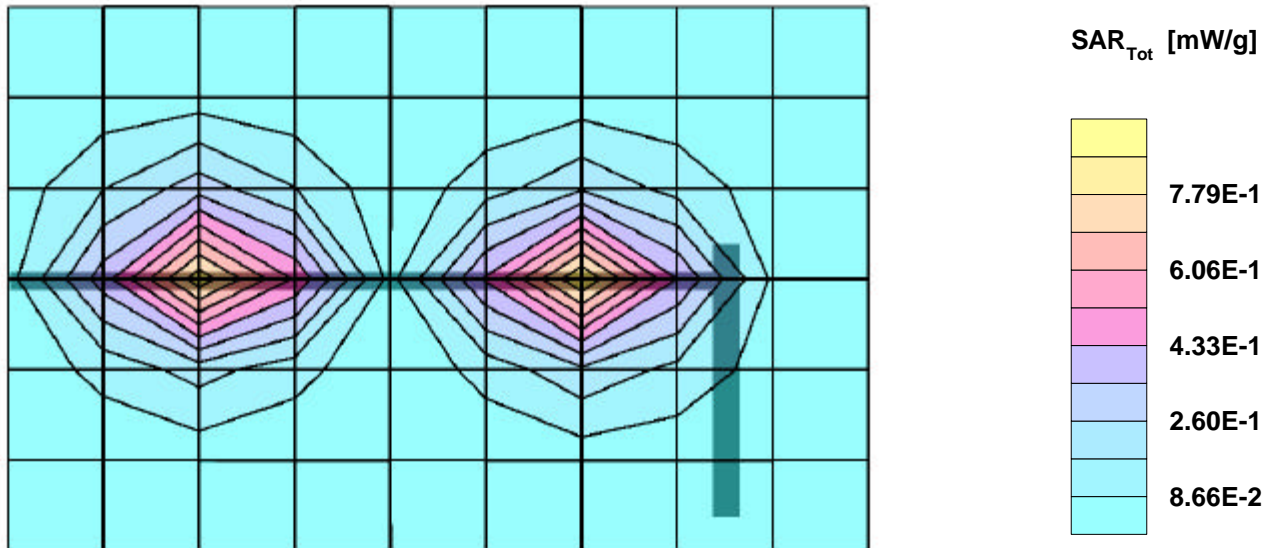

09/07/02

AirCard 555 With Laptop PC (Gateway); Frequency: 1880 MHz

Frequency: 1900 MHz; Crest factor: 1.0

Medium: Muscle 1900 MHz: $s = 1.45 \text{ mho/m}$ $\epsilon_r = 52.0$ $\rho = 1.00 \text{ g/cm}^3$

SAM-1 Phantom; Section; Position:

Probe: ET3DV6 - SN1578; ConvF(5.10,5.10,5.10);

SAR: , , ()

Penetration depth: 10.1 (9.1, 11.5) [mm];

Z-Axis: $D_x = 0.0$, $D_y = 0.0$, $D_z = 2.0$

Ambient Temperature (degree C): 23

Liquid Temperature (degree C): 22.0

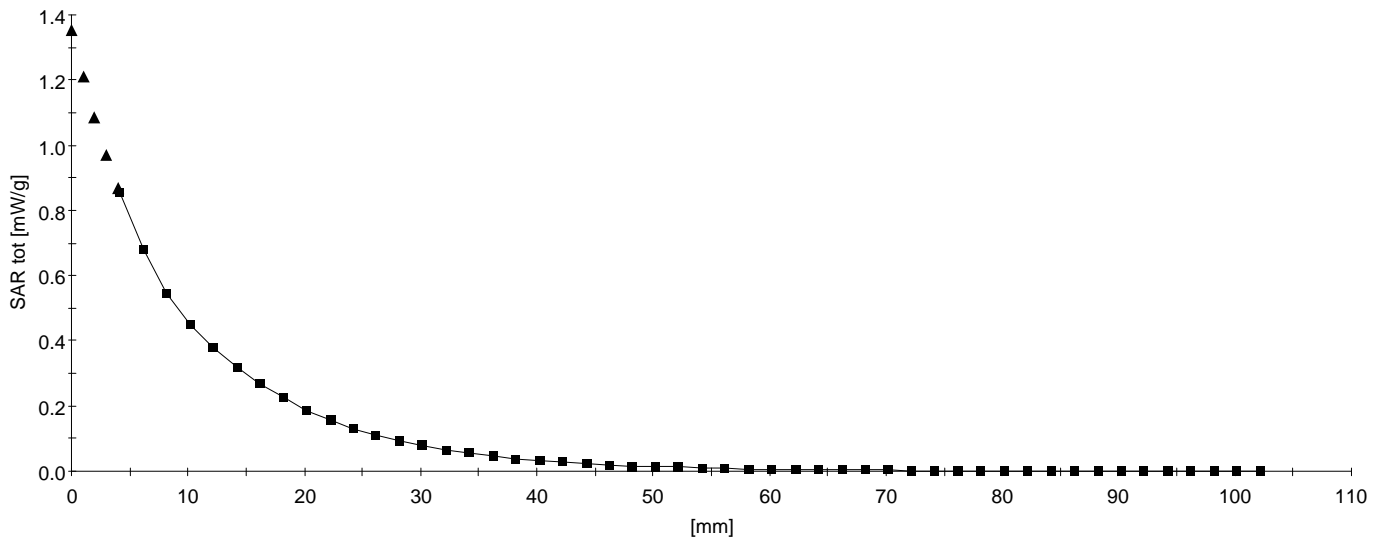

09/07/02

AirCard 555 With Laptop PC (Gateway); Frequency: 1909.95 MHz

Frequency: 1900 MHz; Crest factor: 1.0

Medium: Muscle 1900 MHz: $s = 1.45$ mho/m $\epsilon_r = 52.0$ $\rho = 1.00$ g/cm³

SAM-1 Phantom; Flat Section; Position: (90°,180°)

Probe: ET3DV6 - SN1578; ConvF(5.10,5.10,5.10);

SAR:Cube 5x5x7: Peak: 1.33 mW/g, SAR (1g): 0.757 mW/g, SAR (10g): 0.418 mW/g, (Worst-case extrapolation)

Penetration depth: 9.9 (8.9, 11.4) [mm]; Powerdrift: -0.09 dB

Coarse: Dx = 18.0, Dy = 19.0, Dz = 0.0

Ambient Temperature (degree C): 23

Liquid Temperature (degree C): 22.2

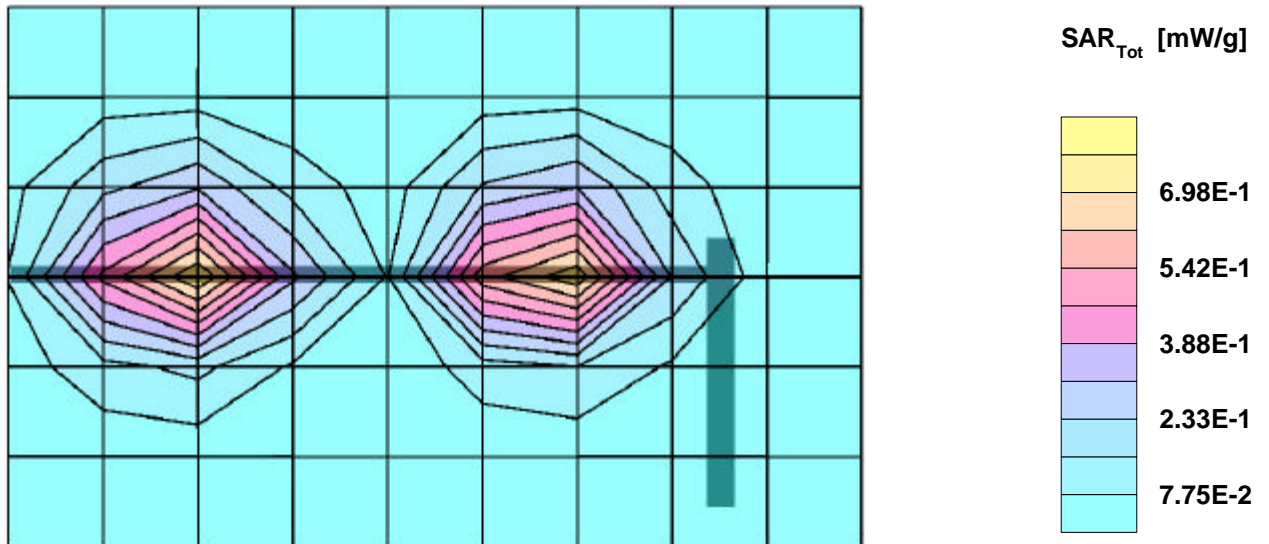

09/07/02

AirCard 555 With Laptop PC (Gateway); Frequency: 1909.95 MHz

Frequency: 1900 MHz; Crest factor: 1.0

Medium: Muscle 1900 MHz: $s = 1.45 \text{ mho/m}$ $\epsilon_r = 52.0$ $\rho = 1.00 \text{ g/cm}^3$

SAM-1 Phantom; Section; Position:

Probe: ET3DV6 - SN1578; ConvF(5.10,5.10,5.10);

SAR: , , ()

Penetration depth: 9.9 (8.9, 11.4) [mm];

Z-Axis: $D_x = 0.0$, $D_y = 0.0$, $D_z = 2.0$

Ambient Temperature (degree C): 23

Liquid Temperature (degree C): 22.2

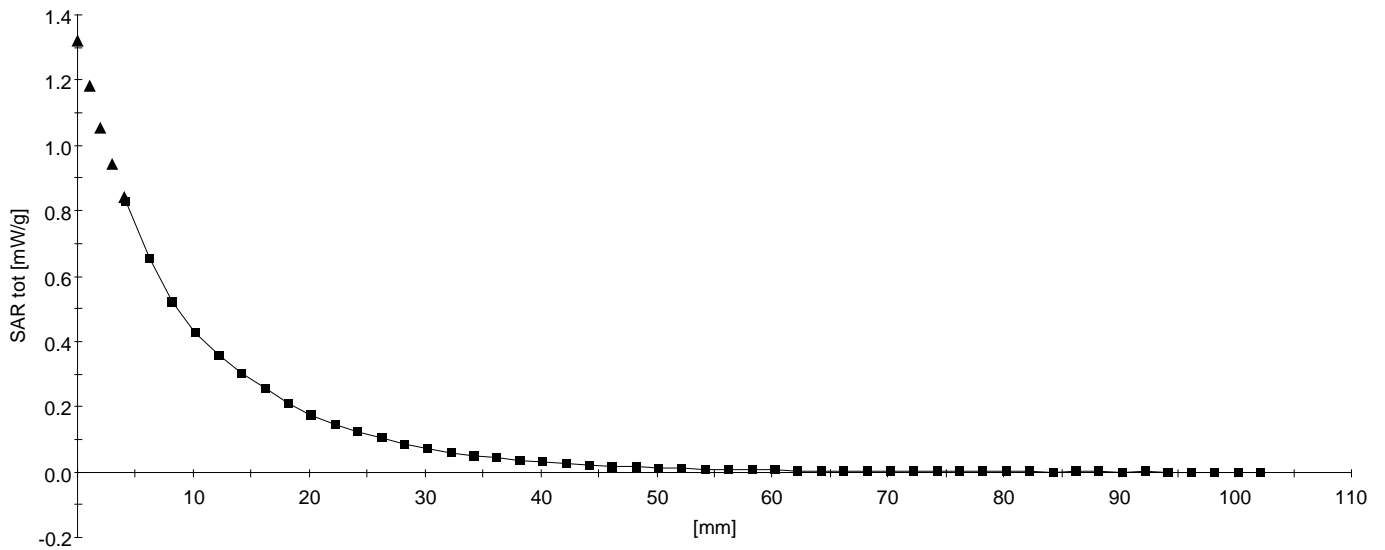

09/07/02

AirCard 555 With Laptop PC (Gateway); Frequency: 1850 MHz

Frequency: 1900 MHz; Crest factor: 1.0

Medium: Muscle 1900 MHz: $s = 1.45$ mho/m $\epsilon_r = 52.0$ $\rho = 1.00$ g/cm³

SAM-1 Phantom; Flat Section; Position: (270°,90°)

Probe: ET3DV6 - SN1578; ConvF(5.10,5.10,5.10);

SAR:Cube 5x5x7: Peak: 0.380 mW/g, SAR (1g): 0.215 mW/g, SAR (10g): 0.120 mW/g, (Worst-case extrapolation)

Penetration depth: 10.0 (9.3, 11.0) [mm]; Powerdrift: 0.01 dB

Coarse: Dx = 18.0, Dy = 19.0, Dz = 0.0

Ambient Temperature (degree C): 23

Liquid Temperature (degree C): 22.3

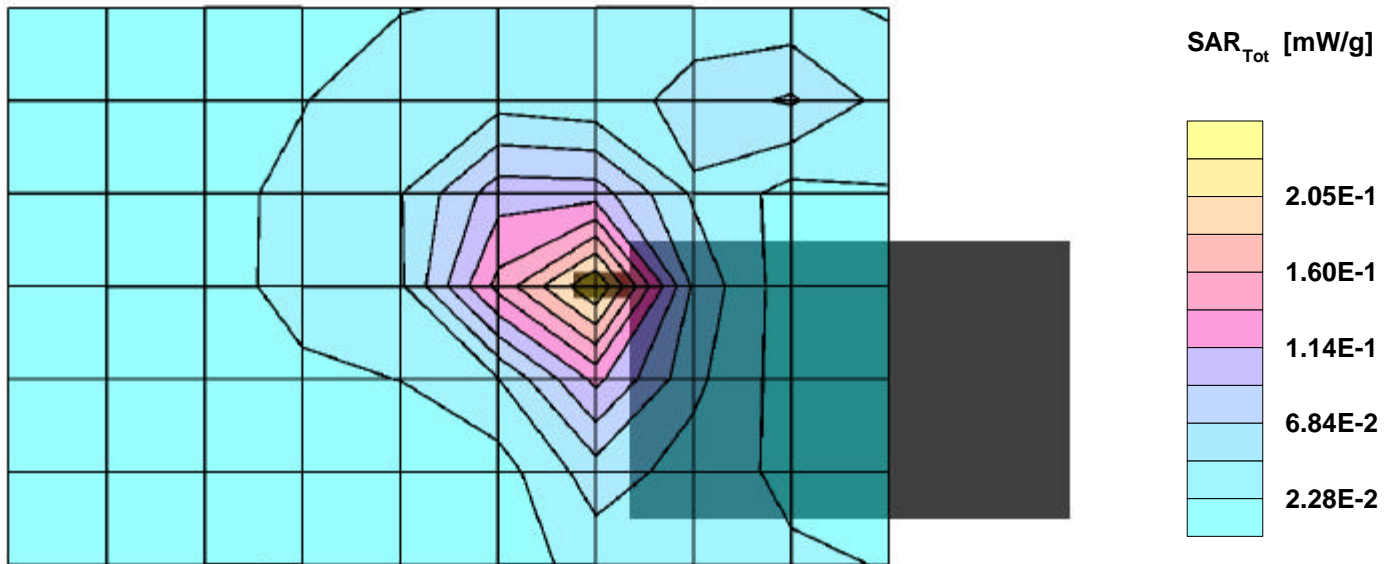

09/07/02

AirCard 555 With Laptop PC (Gateway); Frequency: 1850 MHz

Frequency: 1900 MHz; Crest factor: 1.0

Medium: Muscle 1900 MHz: $s = 1.45 \text{ mho/m}$ $\epsilon_r = 52.0$ $\rho = 1.00 \text{ g/cm}^3$

SAM-1 Phantom; Section; Position:

Probe: ET3DV6 - SN1578; ConvF(5.10,5.10,5.10);

SAR: , , ()

Penetration depth: 9.7 (8.9, 10.7) [mm];

Z-Axis: $D_x = 0.0$, $D_y = 0.0$, $D_z = 2.0$

Ambient Temperature (degree C): 23

Liquid Temperature (degree C): 22.3

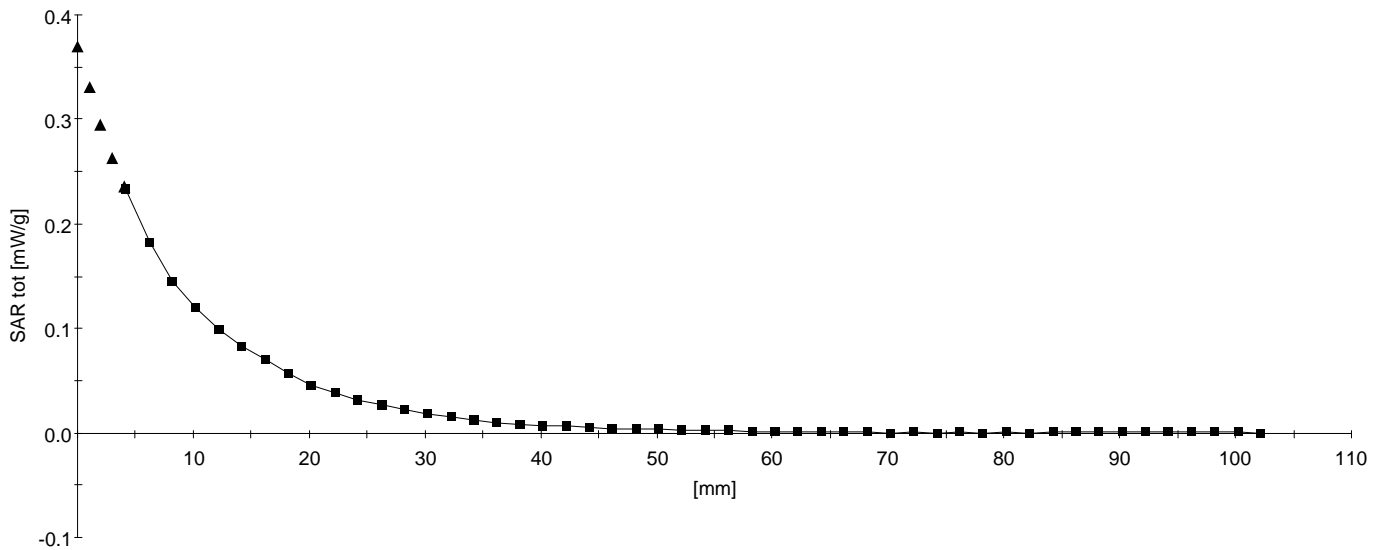

09/07/02

AirCard 555 With Laptop PC (Gateway); Frequency: 1880 MHz

Frequency: 1900 MHz; Crest factor: 1.0

Medium: Muscle 1900 MHz: $s = 1.45$ mho/m $\epsilon_r = 52.0$ $\rho = 1.00$ g/cm³

SAM-1 Phantom; Flat Section; Position: (270°,90°)

Probe: ET3DV6 - SN1578; ConvF(5.10,5.10,5.10);

SAR:Cube 5x5x7: Peak: 0.380 mW/g, SAR (1g): 0.214 mW/g, SAR (10g): 0.118 mW/g, (Worst-case extrapolation)

Penetration depth: 9.5 (8.6, 10.8) [mm]; Powerdrift: 0.02 dB

Coarse: Dx = 18.0, Dy = 19.0, Dz = 0.0

Ambient Temperature (degree C): 23

Liquid Temperature (degree C): 22.3

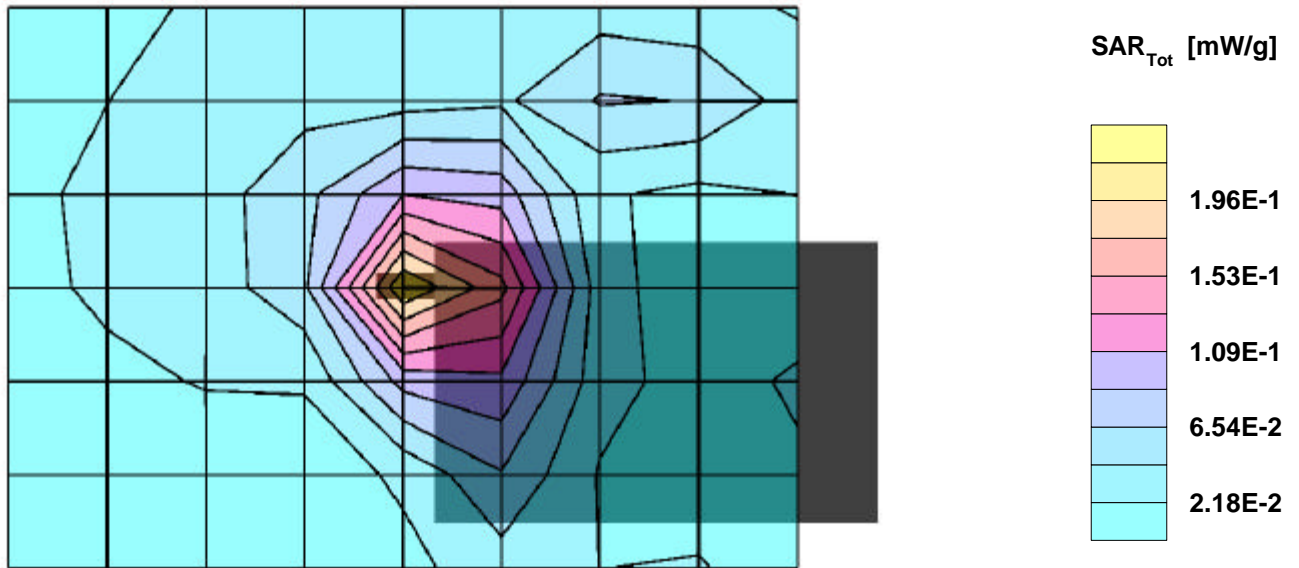

09/07/02

AirCard 555 With Laptop PC (Gateway); Frequency: 1880 MHz

Frequency: 1900 MHz; Crest factor: 1.0

Medium: Muscle 1900 MHz: $\sigma = 1.45 \text{ mho/m}$ $\epsilon_r = 52.0$ $\rho = 1.00 \text{ g/cm}^3$

SAM-1 Phantom; Section; Position:

Probe: ET3DV6 - SN1578; ConvF(5.10,5.10,5.10);

SAR: , , ()

Penetration depth: 9.4 (8.9, 10.3) [mm];

Z-Axis: $D_x = 0.0$, $D_y = 0.0$, $D_z = 2.0$

Ambient Temperature (degree C): 23

Liquid Temperature (degree C): 22.3

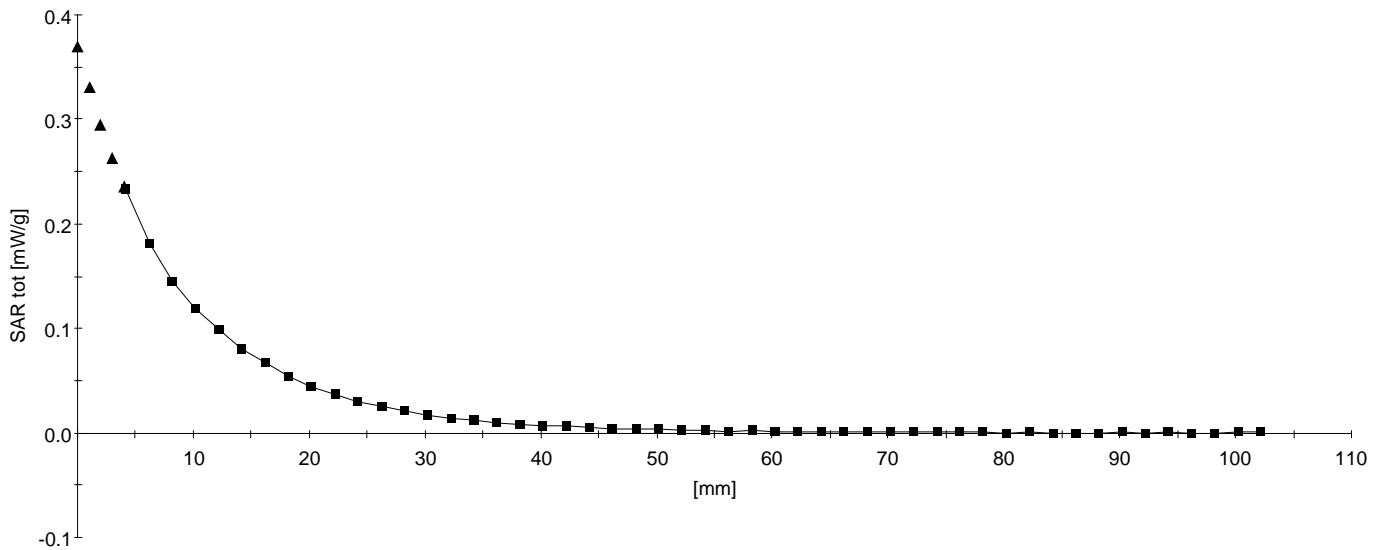

09/07/02

AirCard 555 With Laptop PC (Gateway); Frequency: 1909.95 MHz

Frequency: 1900 MHz; Crest factor: 1.0

Medium: Muscle 1900 MHz: $s = 1.45$ mho/m $\epsilon_r = 52.0$ $\rho = 1.00$ g/cm³

SAM-1 Phantom; Flat Section; Position: (270°,90°)

Probe: ET3DV6 - SN1578; ConvF(5.10,5.10,5.10);

SAR:Cube 5x5x7: Peak: 0.313 mW/g, SAR (1g): 0.180 mW/g, SAR (10g): 0.101 mW/g, (Worst-case extrapolation)

Penetration depth: 9.7 (9.1, 10.5) [mm]; Powerdrift: 0.03 dB

Coarse: Dx = 18.0, Dy = 19.0, Dz = 0.0

Ambient Temperature (degree C): 23

Liquid Temperature (degree C): 22.2

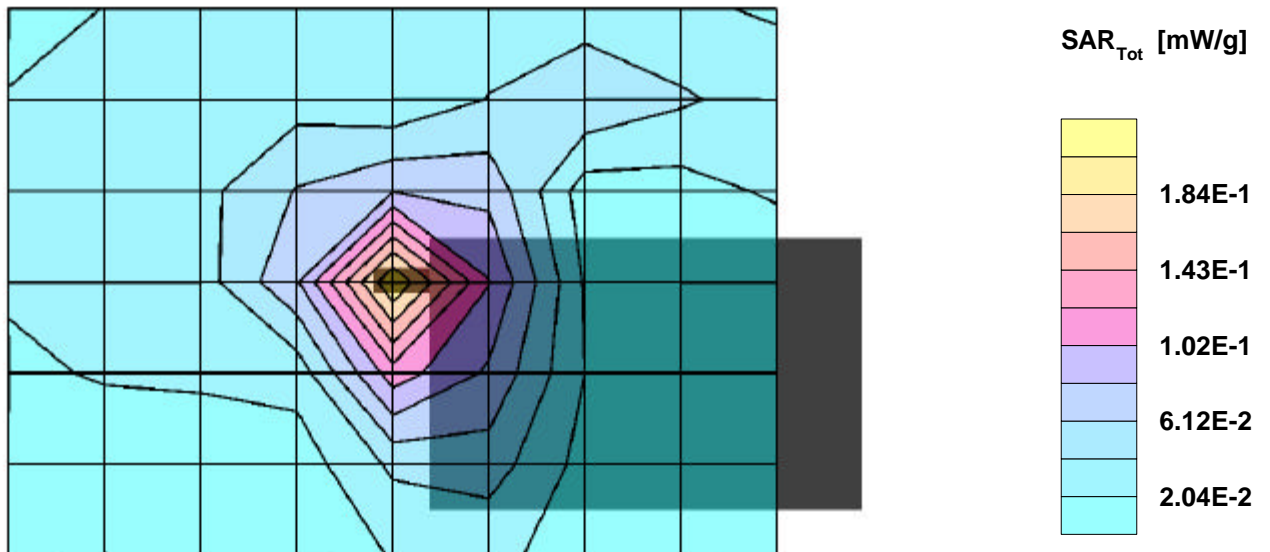

09/07/02

AirCard 555 With Laptop PC (Gateway); Frequency: 1909.95 MHz

Frequency: 1900 MHz; Crest factor: 1.0

Medium: Muscle 1900 MHz: $s = 1.45$ mho/m $\epsilon_r = 52.0$ $\rho = 1.00$ g/cm³

SAM-1 Phantom; Section; Position:

Probe: ET3DV6 - SN1578; ConvF(5.10,5.10,5.10);

SAR: , , ()

Penetration depth: 9.7 (9.0, 10.6) [mm];

Z-Axis: $D_x = 0.0$, $D_y = 0.0$, $D_z = 2.0$

Ambient Temperature (degree C): 23

Liquid Temperature (degree C): 22.2

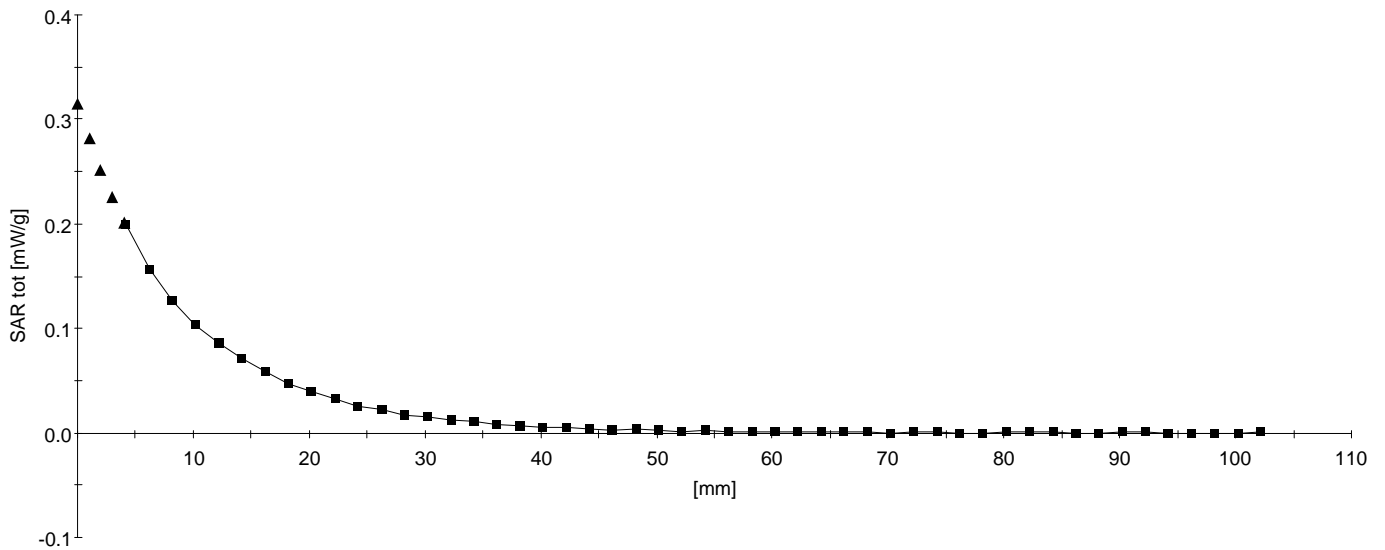

09/07/02

AirCard 555 With Laptop PC (Gateway); Frequency: 1850 MHz

Frequency: 1900 MHz; Crest factor: 1.0

Medium: Muscle 1900 MHz: $s = 1.45$ mho/m $\epsilon_r = 52.0$ $\rho = 1.00$ g/cm³

SAM-1 Phantom; Flat Section; Position: (270°,90°)

Probe: ET3DV6 - SN1578; ConvF(5.10,5.10,5.10);

SAR:Cube 5x5x7: Peak: 0.656 mW/g, SAR (1g): 0.376 mW/g, SAR (10g): 0.216 mW/g, (Worst-case extrapolation)

Penetration depth: 9.6 (8.8, 10.9) [mm]; Powerdrift: -0.01 dB

Coarse: Dx = 18.0, Dy = 19.0, Dz = 0.0

Ambient Temperature (degree C): 23

Liquid Temperature (degree C): 22.5

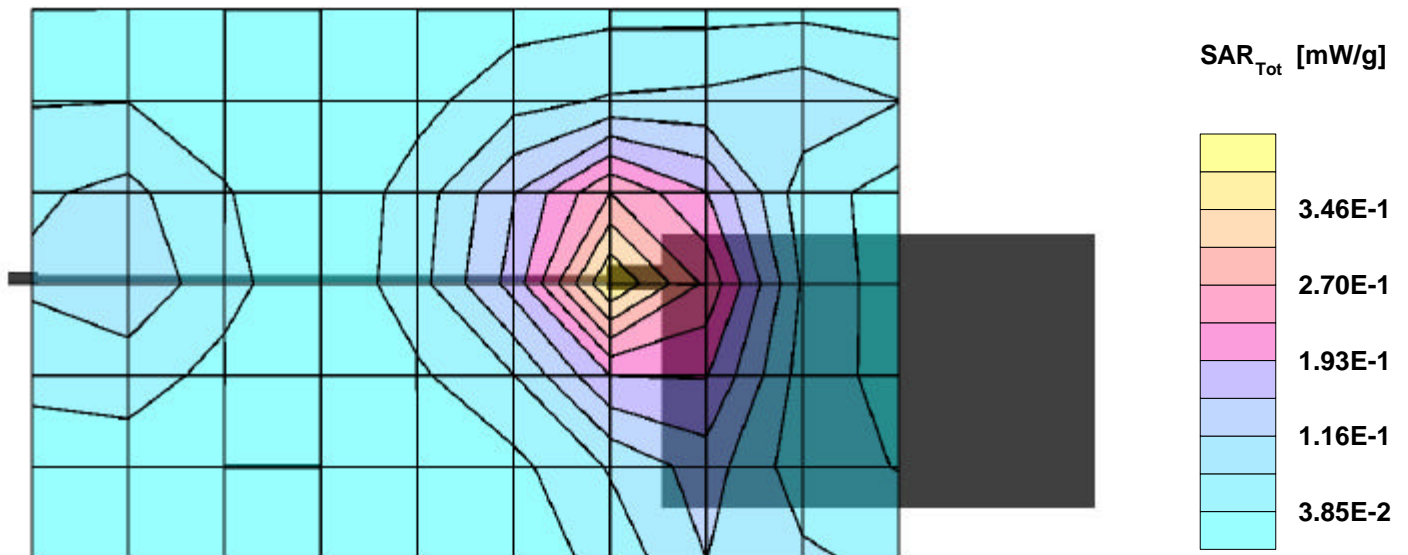

09/07/02

AirCard 555 With Laptop PC (Gateway); Frequency: 1850 MHz

Frequency: 1900 MHz; Crest factor: 1.0

Medium: Muscle 1900 MHz: $s = 1.45 \text{ mho/m}$ $\epsilon_r = 52.0$ $\rho = 1.00 \text{ g/cm}^3$

SAM-1 Phantom; Section; Position:

Probe: ET3DV6 - SN1578; ConvF(5.10,5.10,5.10);

SAR: , , ()

Penetration depth: 9.6 (8.8, 10.8) [mm];

Z-Axis: $D_x = 0.0$, $D_y = 0.0$, $D_z = 2.0$

Ambient Temperature (degree C): 23

Liquid Temperature (degree C): 22.5

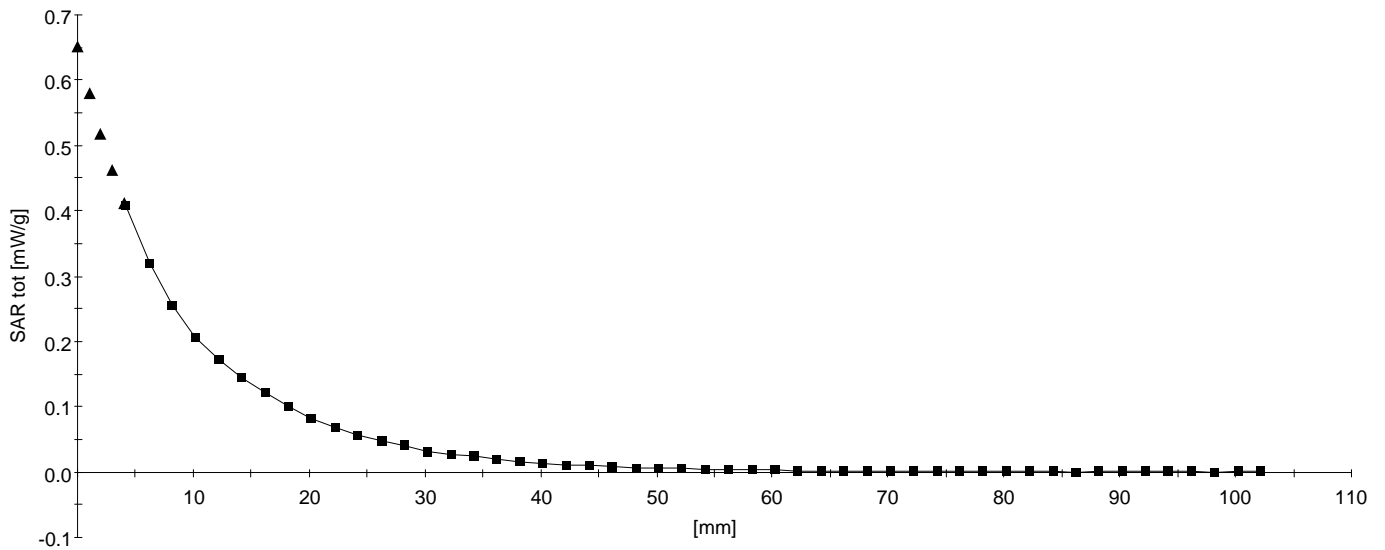

09/07/02

AirCard 555 With Laptop PC (Gateway); Frequency: 1880 MHz

Frequency: 1900 MHz; Crest factor: 1.0

Medium: Muscle 1900 MHz: $s = 1.45$ mho/m $\epsilon_r = 52.0$ $\rho = 1.00$ g/cm³

SAM-1 Phantom; Flat Section; Position: (270°, 90°)

Probe: ET3DV6 - SN1578; ConvF(5.10,5.10,5.10);

SAR:Cube 5x5x7: Peak: 0.531 mW/g, SAR (1g): 0.308 mW/g, SAR (10g): 0.184 mW/g, (Worst-case extrapolation)

Penetration depth: 9.7 (8.9, 10.9) [mm]; Powerdrift: -0.04 dB

Coarse: Dx = 18.0, Dy = 19.0, Dz = 0.0

Ambient Temperature (degree C): 23

Liquid Temperature (degree C): 22.5

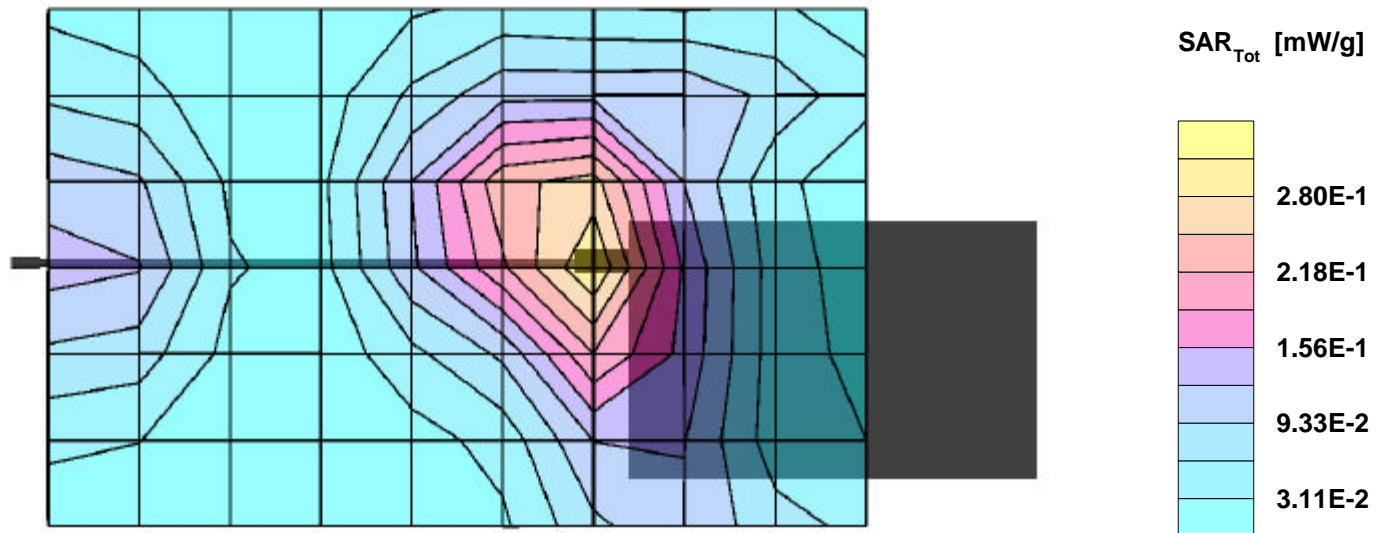

09/07/02

AirCard 555 With Laptop PC (Gateway); Frequency: 1880 MHz

Frequency: 1900 MHz; Crest factor: 1.0

Medium: Muscle 1900 MHz: $s = 1.45$ mho/m $\epsilon_r = 52.0$ $\rho = 1.00$ g/cm³

SAM-1 Phantom; Section; Position:

Probe: ET3DV6 - SN1578; ConvF(5.10,5.10,5.10);

SAR: , , ()

Penetration depth: 9.6 (8.8, 10.9) [mm];

Z-Axis: Dx = 0.0, Dy = 0.0, Dz = 2.0

Ambient Temperature (degree C): 23

Liquid Temperature (degree C): 22.5

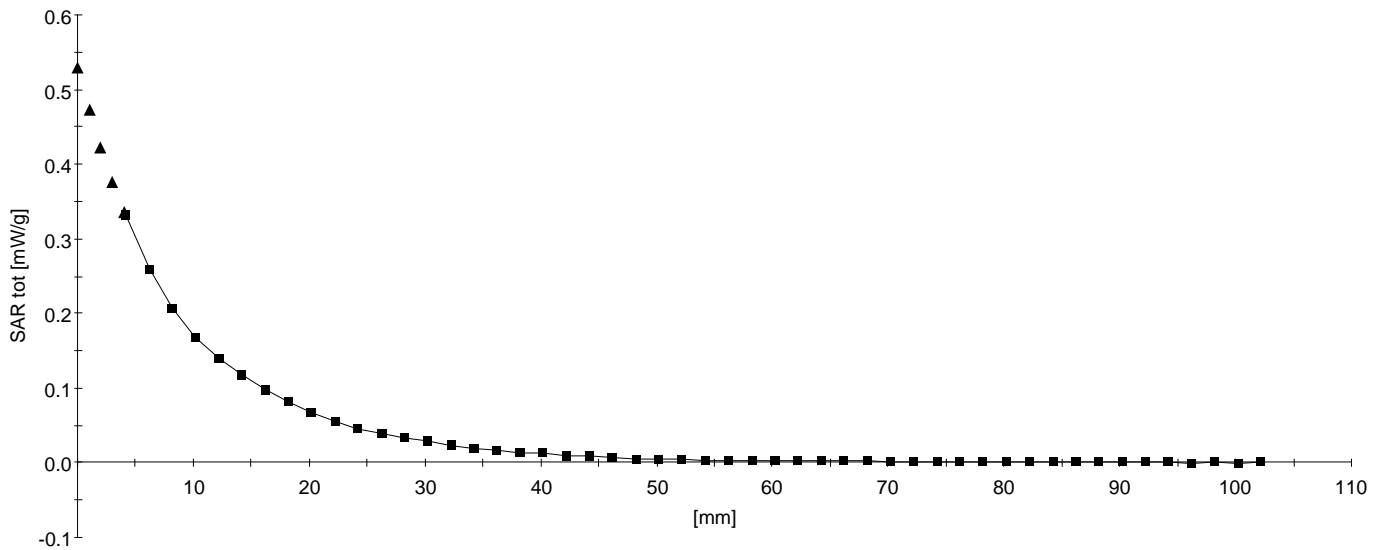

09/07/02

AirCard 555 With Laptop PC (Gateway); Frequency: 1909.95 MHz

Frequency: 1900 MHz; Crest factor: 1.0

Medium: Muscle 1900 MHz: $s = 1.45$ mho/m $\epsilon_r = 52.0$ $\rho = 1.00$ g/cm³

SAM-1 Phantom; Flat Section; Position: (270°,90°)

Probe: ET3DV6 - SN1578; ConvF(5.10,5.10,5.10);

SAR:Cube 5x5x7: Peak: 0.576 mW/g, SAR (1g): 0.328 mW/g, SAR (10g): 0.189 mW/g, (Worst-case extrapolation)

Penetration depth: 9.4 (8.6, 10.6) [mm]; Powerdrift: -0.15 dB

Coarse: Dx = 18.0, Dy = 19.0, Dz = 0.0

Ambient Temperature (degree C): 23

Liquid Temperature (degree C): 22.4

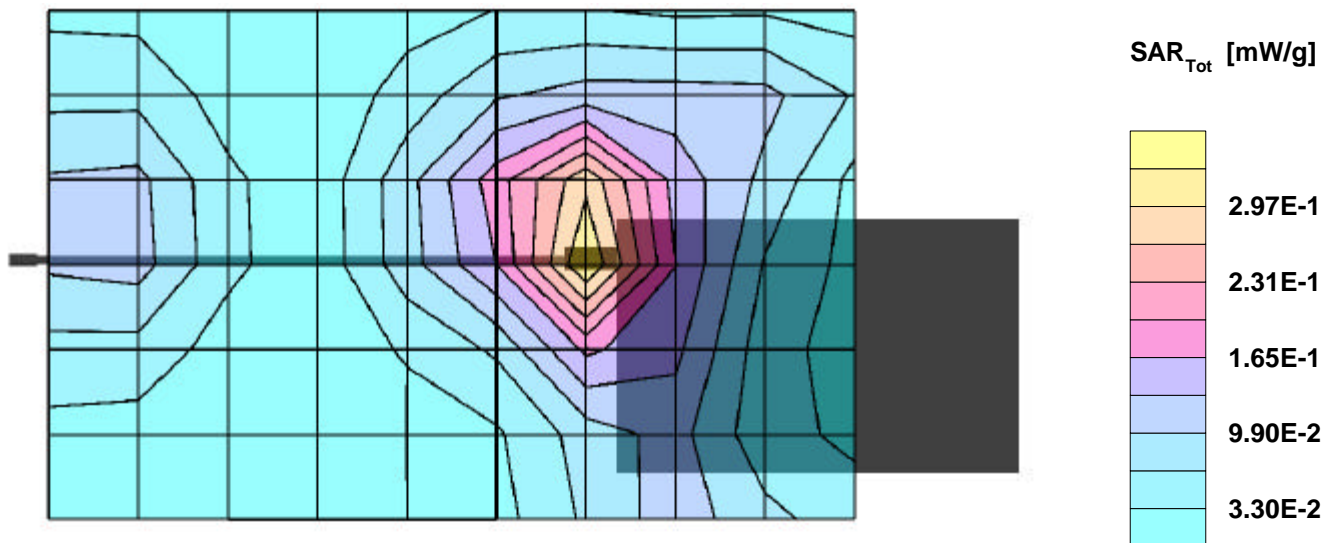

09/07/02

AirCard 555 With Laptop PC (Gateway); Frequency: 1909.95 MHz

Frequency: 1900 MHz; Crest factor: 1.0

Medium: Muscle 1900 MHz: $s = 1.45 \text{ mho/m}$ $\epsilon_r = 52.0$ $\rho = 1.00 \text{ g/cm}^3$

SAM-1 Phantom; Section; Position:

Probe: ET3DV6 - SN1578; ConvF(5.10,5.10,5.10);

SAR: , , ()

Penetration depth: 9.4 (8.6, 10.6) [mm];

Z-Axis: $D_x = 0.0$, $D_y = 0.0$, $D_z = 2.0$

Ambient Temperature (degree C): 23

Liquid Temperature (degree C): 22.4

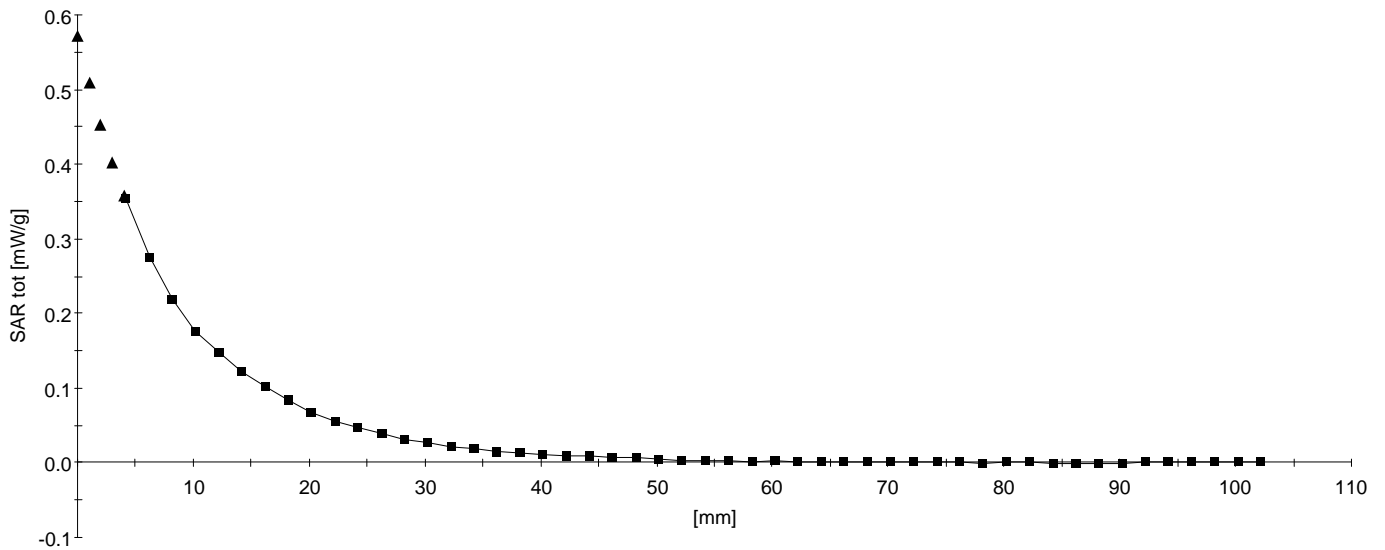

09/07/02

AirCard 555 With Laptop PC (Gateway); Frequency: 1850 MHz

Frequency: 1900 MHz; Crest factor: 1.0

Medium: Muscle 1900 MHz: $s = 1.45$ mho/m $\epsilon_r = 52.0$ $\rho = 1.00$ g/cm³

SAM-1 Phantom; Flat Section; Position: (270°,180°)

Probe: ET3DV6 - SN1578; ConvF(5.10,5.10,5.10);

SAR:Cube 5x5x7: Peak: 1.47 mW/g, SAR (1g): 0.856 mW/g, SAR (10g): 0.481 mW/g, (Worst-case extrapolation)

Penetration depth: 10.5 (9.4, 12.1) [mm]; Powerdrift: -0.00 dB

Coarse: Dx = 18.0, Dy = 20.0, Dz = 0.0

Ambient Temperature (degree C): 23

Liquid Temperature (degree C): 22.5

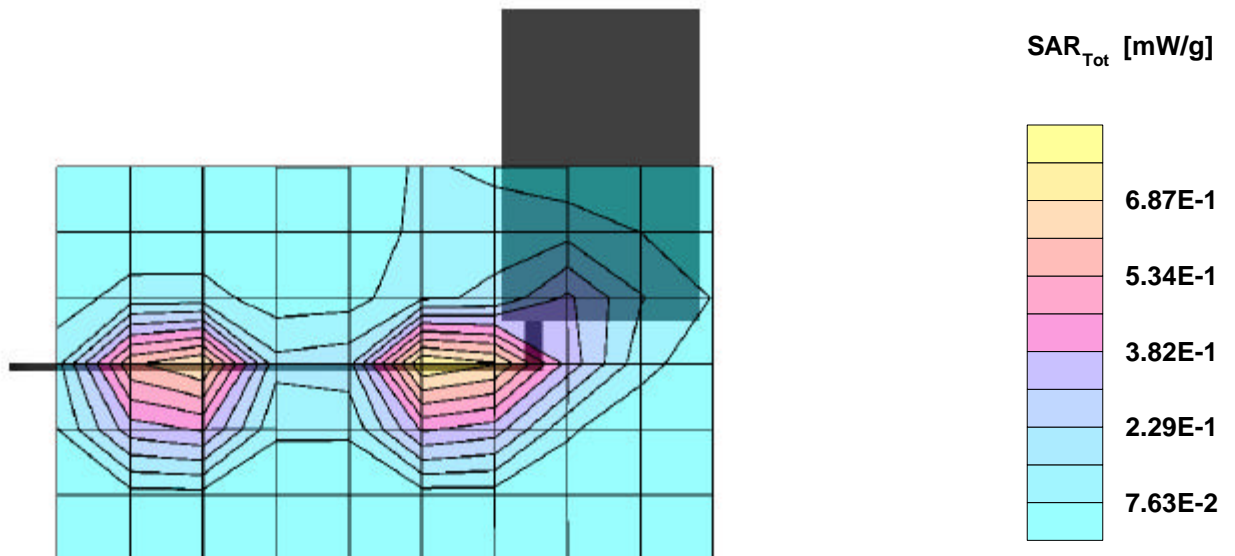

09/07/02

AirCard 555 With Laptop PC (Gateway); Frequency: 1850 MHz

Frequency: 1900 MHz; Crest factor: 1.0

Medium: Muscle 1900 MHz: $s = 1.45$ mho/m $\epsilon_r = 52.0$ $\rho = 1.00$ g/cm³

SAM-1 Phantom; Section; Position:

Probe: ET3DV6 - SN1578; ConvF(5.10,5.10,5.10);

SAR: , , ()

Penetration depth: 10.4 (9.3, 11.9) [mm];

Z-Axis: $D_x = 0.0$, $D_y = 0.0$, $D_z = 2.0$

Ambient Temperature (degree C): 23

Liquid Temperature (degree C): 22.5

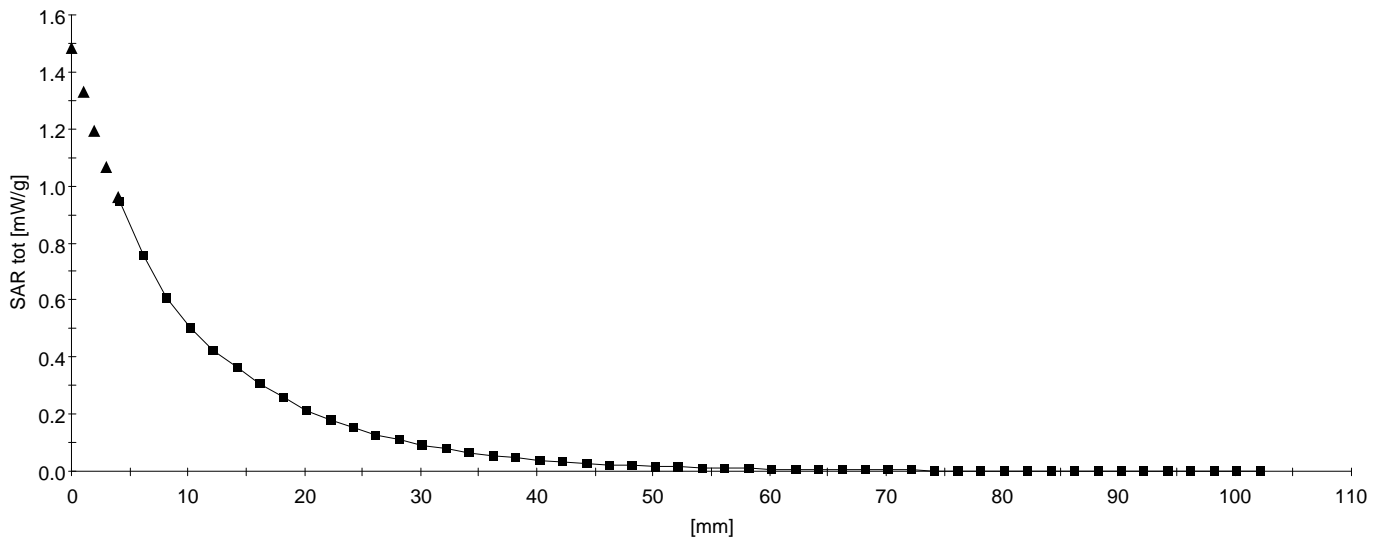

09/07/02

AirCard 555 With Laptop PC (Gateway); Frequency: 1880 MHz

Frequency: 1900 MHz; Crest factor: 1.0

Medium: Muscle 1900 MHz: $s = 1.45$ mho/m $\epsilon_r = 52.0$ $\rho = 1.00$ g/cm³

SAM-1 Phantom; Flat Section; Position: (270°,180°)

Probe: ET3DV6 - SN1578; ConvF(5.10,5.10,5.10);

SAR:Cube 5x5x7: Peak: 2.15 mW/g, SAR (1g): 1.22 mW/g, SAR (10g): 0.672 mW/g, (Worst-case extrapolation)

Penetration depth: 9.8 (8.8, 11.3) [mm]; Powerdrift: 0.05 dB

Coarse: Dx = 18.0, Dy = 20.0, Dz = 0.0

Ambient Temperature (degree C): 23

Liquid Temperature (degree C): 22.5

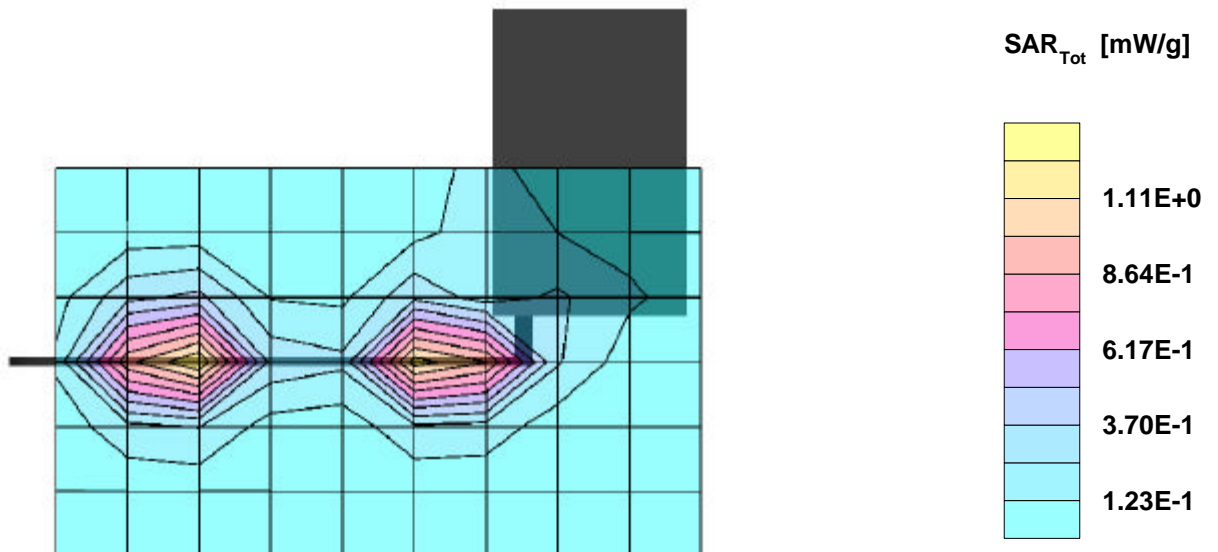

09/07/02

AirCard 555 With Laptop PC (Gateway); Frequency: 1880 MHz

Frequency: 1900 MHz; Crest factor: 1.0

Medium: Muscle 1900 MHz: $s = 1.45 \text{ mho/m}$ $\epsilon_r = 52.0$ $\rho = 1.00 \text{ g/cm}^3$

SAM-1 Phantom; Section; Position:

Probe: ET3DV6 - SN1578; ConvF(5.10,5.10,5.10);

SAR: , , ()

Penetration depth: 9.9 (8.9, 11.3) [mm];

Z-Axis: $D_x = 0.0$, $D_y = 0.0$, $D_z = 2.0$

Ambient Temperature (degree C): 23

Liquid Temperature (degree C): 22.5

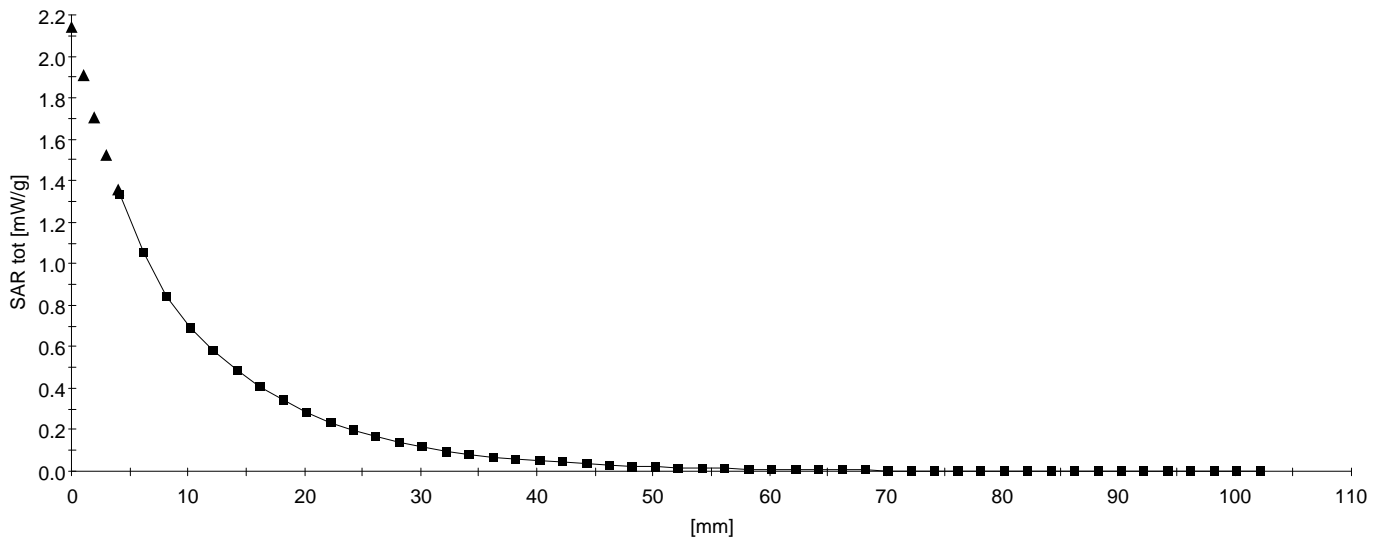

09/07/02

AirCard 555 With Laptop PC (Gateway); Frequency: 1909.95 MHz

Frequency: 1900 MHz; Crest factor: 1.0

Medium: Muscle 1900 MHz: $\sigma = 1.45 \text{ mho/m}$ $\epsilon_r = 52.0$ $\rho = 1.00 \text{ g/cm}^3$

SAM-1 Phantom; Flat Section; Position: (270°, 180°)

Probe: ET3DV6 - SN1578; ConvF(5.10,5.10,5.10);

SAR:Cube 5x5x7: Peak: 1.84 mW/g, SAR (1g): 1.05 mW/g, SAR (10g): 0.578 mW/g, (Worst-case extrapolation)

Penetration depth: 10.2 (9.1, 11.7) [mm]; Powerdrift: -0.01 dB

Coarse: Dx = 19.0, Dy = 20.0, Dz = 0.0

Ambient Temperature (degree C): 23

Liquid Temperature (degree C): 22.4

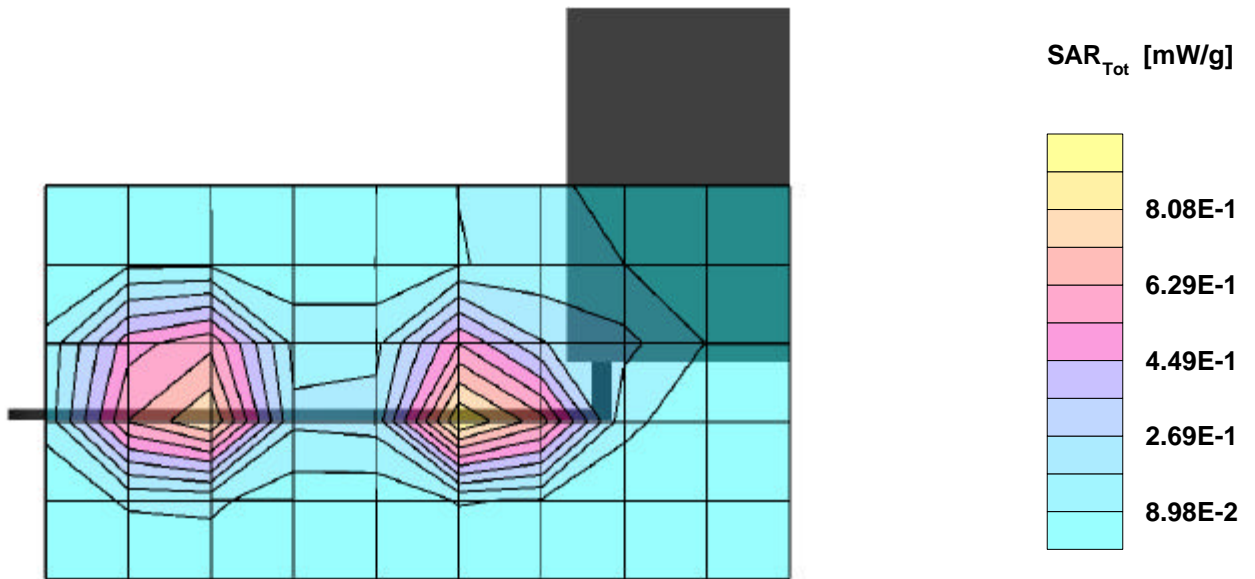

09/07/02

AirCard 555 With Laptop PC (Gateway); Frequency: 1909.95 MHz

Frequency: 1900 MHz; Crest factor: 1.0

Medium: Muscle 1900 MHz: $s = 1.45$ mho/m $\epsilon_r = 52.0$ $\rho = 1.00$ g/cm³

SAM-1 Phantom; Section; Position:

Probe: ET3DV6 - SN1578; ConvF(5.10,5.10,5.10);

SAR: , , ()

Penetration depth: 9.9 (8.9, 11.3) [mm];

Z-Axis: Dx = 0.0, Dy = 0.0, Dz = 2.0

Ambient Temperature (degree C): 23

Liquid Temperature (degree C): 22.4

