



**FCC CFR47 CERTIFICATION**

**PARTS 22H and 24E**

**TEST REPORT**

*FOR*

**850/900/1800/1900MHZ QUADBAND PC CARD**

**MODEL: AirCard 775**

**FCC ID: N7NAC775**

**REPORT NUMBER: 03U2631-1**

**ISSUE DATE: JUNE 08, 2004**

*Prepared for*  
**SIERRA WIRELESS INC.**  
**13811 WIRELESS WAY**  
**RICHMOND, BRITISH COLUMBIA**  
**CANADA**

*Prepared by*  
**COMPLIANCE CERTIFICATION SERVICES**  
**561F MONTEREY ROAD, ROUTE 2**  
**MORGAN HILL, CA 95037, USA**  
**TEL: (408) 463-0885**  
**FAX: (408) 463-0888**



---

## TABLE OF CONTENT

<b>1.</b>	<b>TEST RESULT CERTIFICATION .....</b>	<b>3</b>
<b>2.</b>	<b>EUT DESCRIPTION .....</b>	<b>4</b>
<b>3.</b>	<b>TEST METHODOLOGY .....</b>	<b>4</b>
<b>4.</b>	<b>TEST FACILITY .....</b>	<b>4</b>
<b>5.</b>	<b>ACCREDITATION AND LISTING .....</b>	<b>4</b>
<b>6.</b>	<b>MEASURING INSTRUMENT CALIBRATION .....</b>	<b>4</b>
<b>7.</b>	<b>INSTRUMENTATION LIST.....</b>	<b>5</b>
<b>8.</b>	<b>TEST SETUP, PROCEDURE AND RESULT.....</b>	<b>6</b>
8.1.	SECTION 2.1046: RF POWER OUTPUT .....	6
8.2.	SECTION 2.1053: FIELD STRENGTH OF SPURIOUS RADIATION .....	14
8.3.	RADIATED EMISSION .....	19
8.4.	POWERLINE CONDUCTED EMISSION.....	25

## 1. TEST RESULT CERTIFICATION

**COMPANY NAME:** SIERRA WIRELESS INC., YW  
13811 WIRELESS WAY  
RICHMOND, BRITISH COLUMBIA  
CANADA

**EUT DESCRIPTION:** 850/900/1800/1900MHz QUADBAND PC CARD

**MODEL NAME:** AIRCARD 775

**DATE TESTED:** JUNE 02 - JUNE 04, 2004

TYPE OF EQUIPMENT	INTENTIONAL RADIATOR, CELL PHONE
MEASUREMENT PROCEDURE	ANSI 63.4 / 2001, TIA/EIA 603
PROCEDURE	CERTIFICATION
FCC RULE	CFR 47 PART 22 SUBPART H AND PART 24 SUBPART E

Compliance Certification Services, Inc. tested the above equipment for compliance with the requirement set forth in CFR 47, PART 22 Subpart H and PART 24 subpart E Cellular Radiotelephone Service. The equipment in the configuration described in this report, shows the measured emission levels emanating from the equipment do not exceed the specified limit.

**Note :** This document reports conditions under which testing was conducted and results of tests performed. This document may not be altered or revised in any way unless done so by Compliance Certification Services and all revisions are duly noted in the revisions section. Any alteration of this document not carried out by Compliance Certification Services will constitute fraud and shall nullify the document.

Tested By:

Released For CCS By:

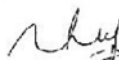
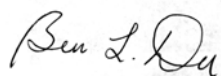

---

VIEN TRAN  
EMC TECHNICIAN  
COMPLIANCE CERTIFICATION SERVICES

---

THU CHAN  
EMC SUPERVISOR  
COMPLIANCE CERTIFICATION SERVICES

## **2. EUT DESCRIPTION**

The QuadBand (850/ 900/ 1800/ 1900MHz) PC Card has an output power 31.7dBm / 1479mW (ERP, GPRS) of GSM 850, and 32.0dBm / 1584mW (EIRP, GPRS) of PCS1900, which is designed for the Cellular & PCS bands transmitting of frequency range 824 ~ 849MHz and 1850 ~ 1990MHz.

## **3. TEST METHODOLOGY**

Both conducted and radiated testing were performed according to the procedures documented on chapter 13 of ANSI C63.4 and FCC CFR 47 2.1046, 2.1047, 2.1049, 2.1051, 2.1053, 2.1055 and 2.1057.

## **4. TEST FACILITY**

The sites and measurement facilities used to collect the radiated data are located at 561F Monterey Road, Morgan Hill, California, USA. The sites are constructed in conformance with the requirements of ANSI C63.7, ANSI C63.4 and CISPR Publication 22.

## **5. ACCREDITATION AND LISTING**

The test facilities used to perform radiated and conducted emissions tests are accredited by National Voluntary Laboratory Accreditation Program for the specific scope of accreditation under Lab Code: 200065-0 to perform Electromagnetic Interference tests according to FCC PART 15 AND CISPR 22 requirements. No part of this report may be used to claim or imply product endorsement by NVLAP or any agency of the US Government. In addition, the test facilities are listed with Federal Communications Commission (reference no: 31040/SIT (1300B3) and 31040/SIT (1300F2))

## **6. MEASURING INSTRUMENT CALIBRATION**

The measuring equipment, which was utilized in performing the tests documented herein, has been calibrated in accordance with the manufacturer's recommendations for utilizing calibration equipment, which is traceable to recognized national standards.

## 7. INSTRUMENTATION LIST

<b>TEST EQUIPMENT LIST</b>				
<b>Name of Equipment</b>	<b>Manufacturer</b>	<b>Model No.</b>	<b>Serial No.</b>	<b>Due Date</b>
Spectrum Analyzer	Agilent	E4446A	MY43360112	1/13/2005
Amplifier 1-26GHz	MITEQ	NSP2600-SP	924342	4/25/2005
Antenna, Horn 1 ~ 18 GHz	EMCO	3115	6717	2/4/2005
Antenna, Horn 1 ~ 18 GHz	EMCO	3115	3328	2/4/2005
EMI Test Receiver	R & S	ESHS 20	827129/006	7/17/2004
LISN, 10 kHz ~ 30 MHz	FCC	50/250-25-2	114	10/13/2004
Line Filter	Lindgren	LMF-3489	497	CNR
LISN, 10 kHz ~ 30 MHz	Solar	8012-50-R-24-BNC	837990	10/13/2004
AC Power Source, 10KVA	ACS	AFC-10K-AFC-2	J1568	CNR
HPF	MICROLAB	FH-1500H	N/A	N/A
HPF	MICROLAB	FH-2400H	N/A	N/A
Tune Dipole	ETS	DB-4	1629	5/14/2005

## 8. TEST SETUP, PROCEDURE AND RESULT

### 8.1. SECTION 2.1046: RF POWER OUTPUT

#### MEASUREMENT PROCEDURE

- 1). On a test site, the EUT shall be placed on a turntable, and in the position closest to the normal use as declared by the user.
- 2). The test antenna shall be oriented initially for vertical polarization located 3m from the EUT to correspond to the frequency of the transmitter.
- 3). The output of the test antenna shall be connected to the measuring receiver and either a peak or quasi-peak detector was used for the measurement as indicated on the report. The detector selection is based on how close the emission level was approaching the limit.
- 4). The transmitter shall be placed 0.80 meter above the ground plane, the X, Y, and Z positions shall be tested and the worst case reported. The transmitter shall be switched on with typical modulation and the measurement receiver shall be tuned to the frequency of the transmitter under test.
- 5). The test antenna shall be raised and lowered through the specified range of height until a maximum signal level is detected by the measuring receiver.
- 6). The transmitter shall than be rotated through 360° in the horizontal plane, until the maximum signal level is detected by the measuring receiver.
- 7). The test antenna shall be raised and lowered again through the specified range of height until a maximum signal level is detected by the measuring receiver.
- 8). The maximum signal level detected by the measuring receiver shall be noted.
- 9). The transmitter shall be replaced by a tuned dipole or horn antenna (substitution antenna).
- 10). The substitution antenna shall be oriented for vertical polarization and the length of the substitution antenna shall be adjusted to correspond to the frequency of the transmitter.
- 11). The substitution antenna shall be connected to a calibrated signal generator.

12). If necessary, the input attenuator setting of the measuring receiver shall be adjusted in order to increase the sensitivity of the measuring receiver.

13). The test antenna shall be raised and lowered through the specified range of the height to ensure that the maximum signal is received.

14). The input signal to the substitution antenna shall be adjusted to the level that produces a level detected by the measuring receiver, that is equal to the level noted while the transmitter radiated power was measured, corrected for the change of input attenuation setting of the measuring receiver.

15). The input level to the substitution antenna shall be recorded as power level in dBm, corrected for any change of input attenuator setting of the measuring receiver.

16). The measurement shall be repeated with the test antenna and the substitution antenna oriented for horizontal polarization.

17). The measure of the effective radiated power is the larger of the two levels recorded, at the input to the substitution antenna, corrected for the gain of the substitution antenna if necessary.

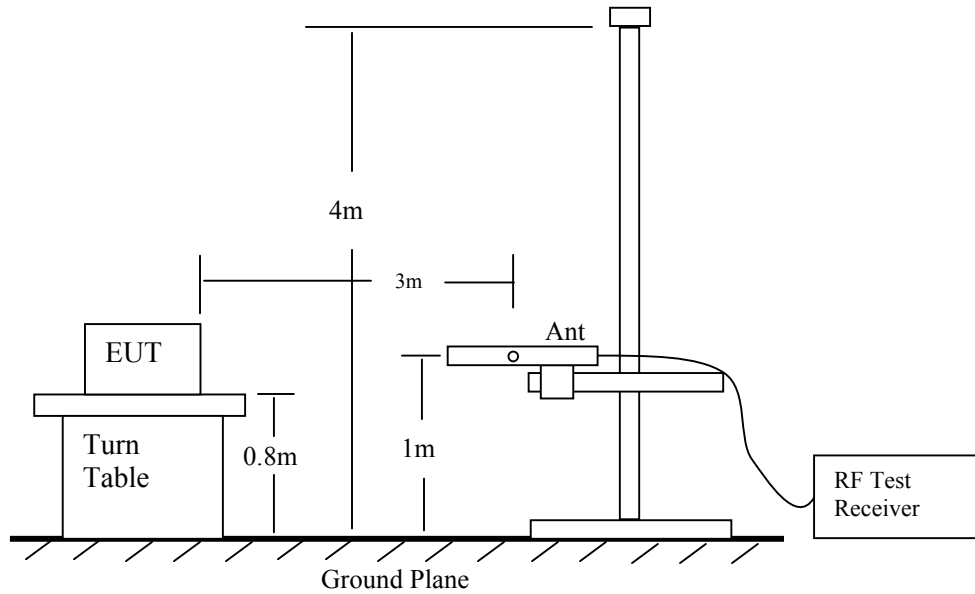

Radiated Emission Measurement 30 to 1000 MHz

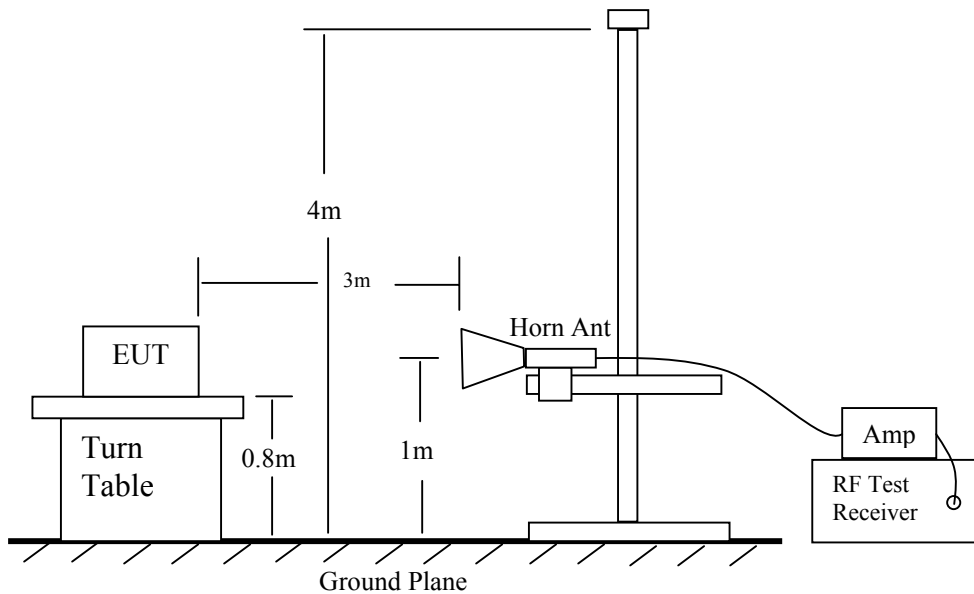

Radiated Emission Above 1000 MHz



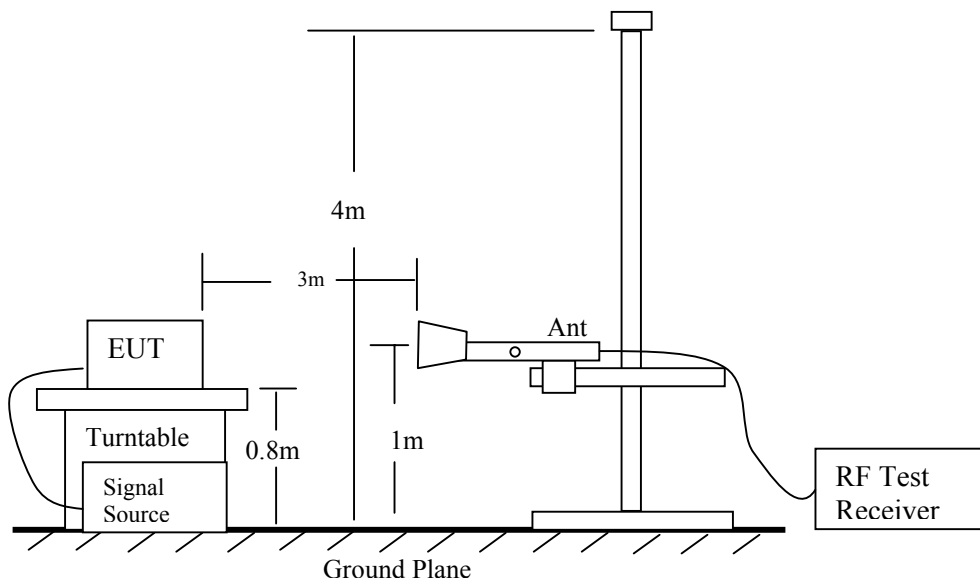

Radiated Emission Measurement

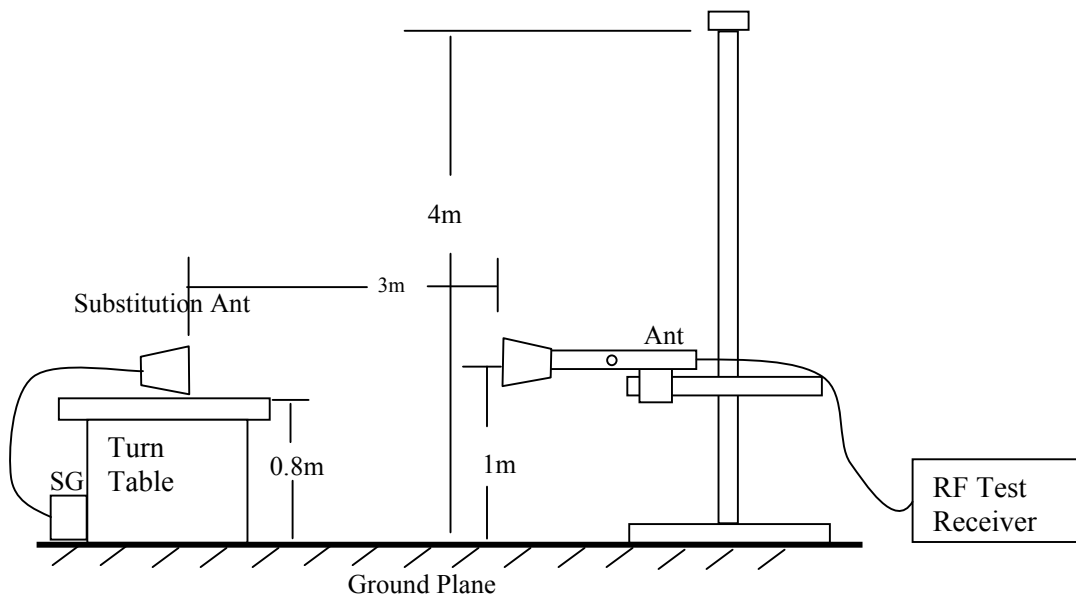

Radiated Emission – Substitution Method set-u

MEASUREMENT RESULT:

850MHz and 1900MHz Output Power Measurement (4 slots TX at max power):

**GSM850**

	Ch.#	Freq. (MHz)	Peak Output Power ERP (dBm)
Low Ch.	128	824.2	31.00
Mid Ch.	190	836.1	31.20
High Ch.	251	848.8	31.70

**PCS1900**

	Ch.#	Freq. (MHz)	Peak Output Power EIRP (dBm)
Low Ch.	512	1850.2	32.00
Mid Ch.	661	1880	31.60
High Ch.	810	1909.8	31.50

**Radiated Emissions**

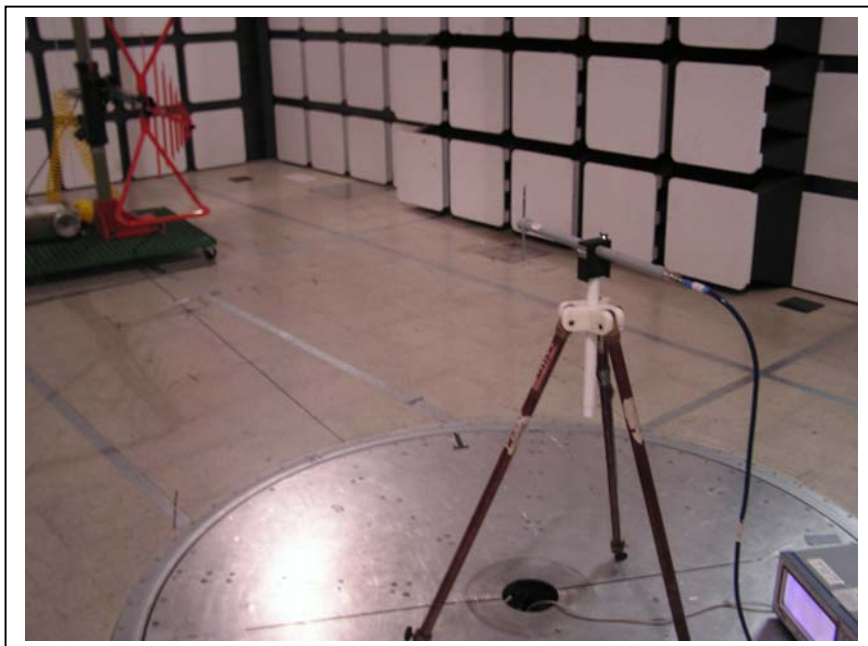
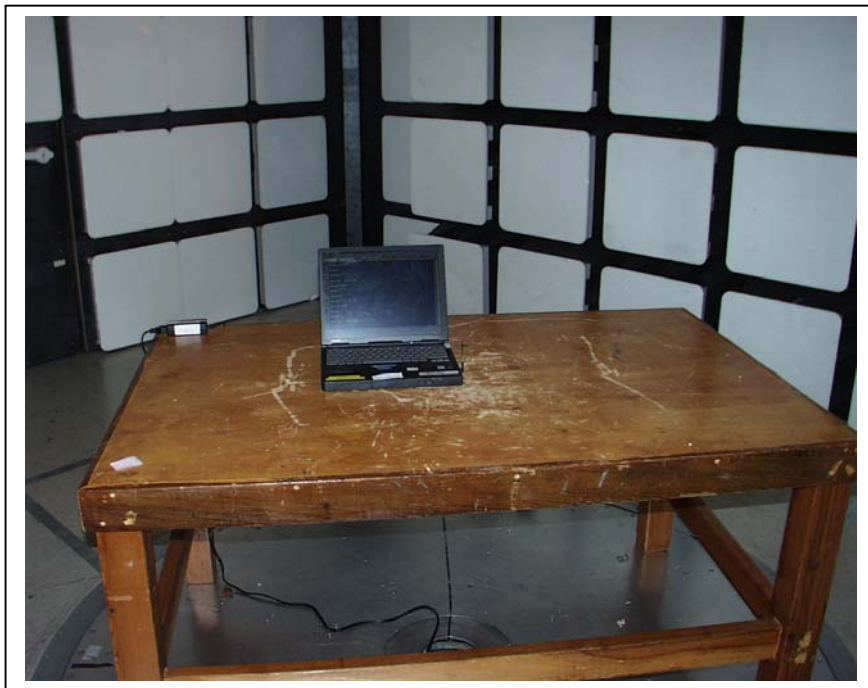

Output Power (ERP), 850MHZ - Low / Mid / High Channel Fundamental

06/09/04 **High Frequency Substitution Measurement**  
 Compliance Certification Services, Morgan Hill 5m Chamber Site

Test Engr: Vien Chan  
 Project #: 04U2631-1  
 Company: Sierra Wireless Inc. YW  
 EUT Descrip.: Quad-band 850/900/1800/1900 MHz PC Card  
 EUT M/N: AirCard 775  
 Test Target: FCC 22  
 Mode Oper: Normal Antenna Position with 4 slots TX at max power

**Test Equipment:**

EMCO Horn 1-18GHz      Horn > 18GHz      Limit       High Pass Filter  
 Dipole      ERP

Hi Frequency Cables      Pre-amplifer 1-26GHz      Pre-amplifer 26-40GHz  
 (2 ft)     (2~3 ft)     (4~6 ft)     (12 ft)

f GHz	SA reading (dBuV/m)	Ant. Pol. (H/V)	SG reading (dBm)	CL (dB)	Gain (dBi)	Gain (dBd)	ERP (dBm)	Limit (dBm)	Margin (dB)	Notes
<b>Fundamental (Substitution with Dipole Antenna):</b>										
0.824	104.6	V	31.5	0.5	2.1	0.0	31.0	38.5	-7.5	Low Channel
0.824	104.9	H	28.8	0.5	2.1	0.0	28.3	38.5	-10.2	Low Channel
0.837	104.9	V	31.7	0.5	2.1	0.0	31.2	38.5	-7.3	Mid Channel
0.837	105.6	H	29.5	0.5	2.1	0.0	29.0	38.5	-9.5	Mid Channel
0.849	105.5	V	32.2	0.5	2.1	0.0	31.7	38.5	-6.8	High Channel
0.849	105.3	H	29.3	0.5	2.1	0.0	28.8	38.5	-9.7	High Channel

Output Power (EIRP), 1900 MHz – Low / Mid/ High Channel Fundamental

06/09/04 **High Frequency Substitution Measurement**  
**Compliance Certification Services, Morgan Hill 5m Chamber Site**

Test Engr: Vien Tran  
 Project #: 04U2631-1  
 Company: Sierra Wireless Inc. YW  
 EUT Descrip.: Quad-band 850/900/1800/1900 MHz PC Card  
 EUT M/N: AirCard 775  
 Test Target: FCC 24  
 Mode Oper: Normal Antenna Position with 4 slots TX at max power

**Test Equipment:**

EMCO Horn 1-18GHz  
 T60; S/N: 2238 @3m

Horn > 18GHz

Limit  
 EIRP

High Pass Filter

Hi Frequency Cables  
 (2 ft)  (2~3 ft)  (4~6 ft)  (12 ft)

Pre-amplifer 1-26GHz

Pre-amplifer 26-40GHz

f GHz	SA reading (dBuV/m)	Ant. Pol. (H/V)	SG reading (dBm)	CL (dB)	Gain (dBi)	Gain (dBd)	EIRP (dBm)	Limit (dBm)	Margin (dB)	Notes
<b>Fundamental:</b>										
1.850	99.1	V	26.2	1.4	7.2	5.0	32.0	33.0	-1.0	Low Channel
1.850	90.0	H	17.8	1.4	7.2	5.0	23.6	33.0	-9.4	Low Channel
1.880	98.5	V	25.7	1.4	7.2	5.1	31.6	33.0	-1.4	Mid Channel
1.880	89.8	H	17.7	1.4	7.2	5.1	23.6	33.0	-9.4	Mid Channel
1.910	98.2	V	25.6	1.4	7.2	5.1	31.5	33.0	-1.5	High Channel
1.910	88.9	H	17.0	1.4	7.2	5.1	22.9	33.0	-10.1	High Channel

## 8.2. SECTION 2.1053: FIELD STRENGTH OF SPURIOUS RADIATION

Detector Function Setting of Test Receiver

Frequency Range (MHz)	Detector Function	Resolution Bandwidth	Video Bandwidth
Above 1000	<input checked="" type="checkbox"/> Peak <input type="checkbox"/> Average	<input checked="" type="checkbox"/> 1 MHz <input type="checkbox"/> 1 MHz	<input checked="" type="checkbox"/> 1 MHz <input type="checkbox"/> 10 Hz

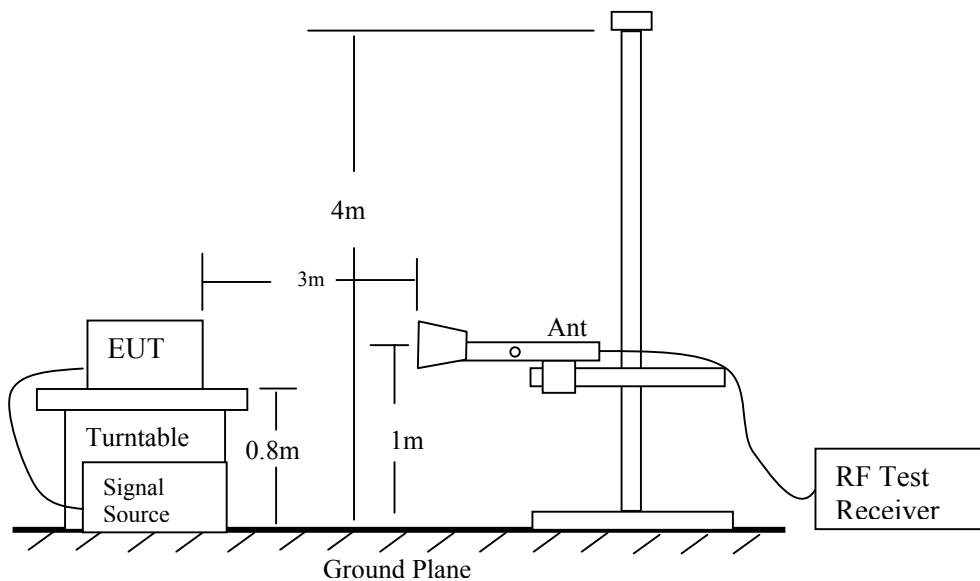

Radiated Emission Measurement

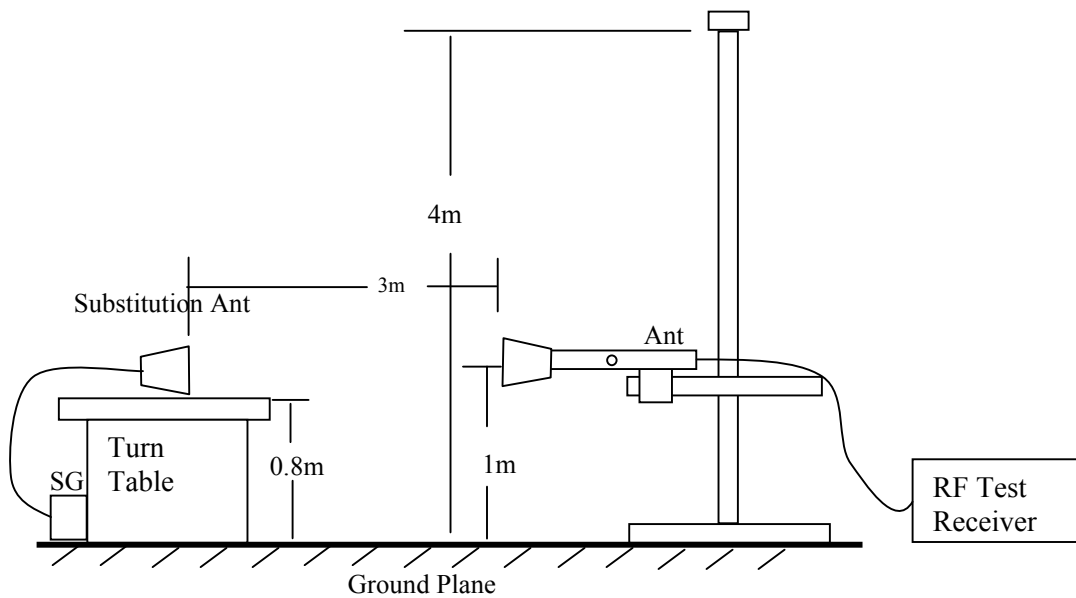

Radiated Emission - Substitution Method set-up

### **TEST PROCEDURE**

- 1). On a test site, the EUT shall be placed on a turntable, and in the position closest to the normal use as declared by the user.
- 2). The test antenna shall be oriented initially for vertical polarization located 1m from the EUT to correspond to the frequency of the transmitter.
- 3). The output of the test antenna shall be connected to the measuring receiver and either a peak or average detector was used for the measurement as indicated on the report. The detector selection is based on how close the emission level was approaching the limit.
- 4). The transmitter shall be switched on, if possible, without the modulation and the measurement receiver shall be tuned to the frequency of the transmitter under test.
- 5). The test antenna shall be raised and lowered through the specified range of height until a maximum signal level is detected by the measuring receiver.
- 6). The transmitter shall then be rotated through 360° in the horizontal plane, until the maximum signal level is detected by the measuring receiver.
- 7). The test antenna shall be raised and lowered again through the specified range of height until a maximum signal level is detected by the measuring receiver.
- 8). The maximum signal level detected by the measuring receiver shall be noted.
- 9). The transmitter shall be replaced by a substitution antenna.
- 10). The substitution antenna shall be oriented for vertical polarization.
- 11). The substitution antenna shall be connected to a calibrated signal generator.
- 12). If necessary, the input attenuator setting of the measuring receiver shall be adjusted in order to increase the sensitivity of the measuring receiver.
- 13). The test antenna shall be raised and lowered through the specified range of the height to ensure that the maximum signal is received.
- 14). The input signal to the substitution antenna shall be adjusted to the level that produces a level detected by the measuring receiver, that is equal to the level noted while the transmitter radiated power was measured, corrected for the change of input attenuation setting of the measuring receiver.
- 15). The input level to the substitution antenna shall be recorded as power level in dBm, corrected for any change of input attenuator setting of the measuring receiver.
- 16). The measurement shall be repeated with the test antenna and the substitution antenna oriented for horizontal polarization.
- 17). The measure of the effective radiated power is the larger of the two levels recorded, at the input to the substitution antenna, corrected for the gain of the substitution antenna if necessary.

### **MEASUREMENT RESULT**

No non-compliance noted, as shown below



850MHz Band - Harmonics / Spurious and Substitution Emissions, Low / Mid / High Channels

06/03/04 **High Frequency Substitution Measurement**  
 Compliance Certification Services, Morgan Hill 5m Chamber Site

Test Engr: Vien Tran  
 Project #: 04U2631-1  
 Company: Sierra Wireless Inc. YW  
 EUT Descrip.: Quad-band 850/900/1800/1900 MHz PC Card  
 EUT M/N: AirCard 775  
 Test Target: FCC 22  
 Mode Oper: Normal Antenna Position with 4 slots TX at max power

**Test Equipment:**

EMCO Horn 1-18GHz  
 T60; S/N: 2238 @3m

Horn > 18GHz

Limit  
 ERP

High Pass Filter

Hi Frequency Cables  
 (2 ft)  (2 ~ 3 ft)  (4 ~ 6 ft)  (12 ft)

Pre-amplifer 1-26GHz  
 T63 Miteq 646456

Pre-amplifer 26-40GHz

f GHz	SA reading (dBuV/m)	Ant. Pol. (H/V)	SG reading (dBm)	CL (dB)	Gain (dBi)	Gain (dBd)	ERP (dBm)	Limit (dBm)	Margin (dB)	Notes
<b>Spurious Harmonic with Horn Antenna:</b>										
<b>Low Channel:</b>										
1.648	55.0	V	-48.9	1.6	7.0	4.8	-45.7	-13.0	-32.7	
2.472	59.0	V	-41.6	1.9	8.2	6.0	-37.4	-13.0	-24.4	
3.296	55.0	V	-43.3	2.3	9.3	7.1	-38.4	-13.0	-25.4	
4.120	50.0	V	-46.2	2.6	9.8	7.6	-41.2	-13.0	-28.2	
1.648	60.0	H	-43.2	1.6	7.0	4.8	-40.0	-13.0	-27.0	
2.472	53.0	H	-47.4	1.9	8.2	6.0	-43.2	-13.0	-30.2	
3.296	55.0	H	-43.2	2.3	9.3	7.1	-38.3	-13.0	-25.3	
<b>Mid Channel:</b>										
1.673	62.0	V	-41.8	1.6	7.0	4.8	-38.6	-13.0	-25.6	
2.509	56.2	V	-44.3	1.9	8.3	6.1	-40.1	-13.0	-27.1	
3.346	52.0	V	-46.2	2.3	9.3	7.2	-41.3	-13.0	-28.3	
4.183	50.0	V	-46.1	2.6	9.9	7.7	-41.1	-13.0	-28.1	
1.673	55.0	H	-48.1	1.6	7.0	4.8	-44.8	-13.0	-31.8	
2.509	51.0	H	-49.3	1.9	8.3	6.1	-45.1	-13.0	-32.1	
3.346	54.0	H	-44.1	2.3	9.3	7.2	-39.2	-13.0	-26.2	
<b>High Channel:</b>										
1.695	58.4	V	-45.3	1.6	7.0	4.9	-42.0	-13.0	-29.0	
2.550	49.0	V	-51.3	2.0	8.3	6.2	-47.1	-13.0	-34.1	
3.398	55.2	V	-42.8	2.3	9.3	7.2	-38.0	-13.0	-25.0	
4.245	52.0	V	-44.1	2.7	10.0	7.8	-38.9	-13.0	-25.9	
1.695	50.0	H	-53.0	1.6	7.0	4.9	-49.7	-13.0	-36.7	
2.550	50.0	H	-50.1	2.0	8.3	6.2	-45.9	-13.0	-32.9	
3.398	54.0	H	-43.9	2.3	9.3	7.2	-39.1	-13.0	-26.1	
<b>Note: No other emissions were found up to 10GHz.</b>										

1900MHz Band - Harmonics / Spurious and Substitution Emissions, Low / Mid / High Channels:

06/04/04 **High Frequency Substitution Measurement**  
 Compliance Certification Services, Morgan Hill 5m Chamber Site

Test Engr: Vien Tran  
 Project #: 04U2631-1  
 Company: Sierra Wireless Inc. YW  
 EUT Descrip.: Quad-band 850/900/1800/1900 MHz PC Card  
 EUT MN: AirCard 775  
 Test Target: FCC 24  
 Mode Oper: Normal Antenna Position with 4 slots TX at max power

**Test Equipment:**

EMCO Horn 1-18GHz  
 T60; S/N: 2238 @3m

Horn > 18GHz

Limit  
 EIRP

High Pass Filter

Hi Frequency Cables  
 (2 ft)  (2 ~ 3 ft)  (4 ~ 6 ft)  (12 ft)

Pre-amplifier 1-26GHz  
 T63 Miteq 646456

Pre-amplifier 26-40GHz

f GHz	SA reading (dBuV/m)	Ant. Pol. (H/V)	SG reading (dBm)	CL (dB)	Gain (dBi)	Gain (dBd)	EIRP (dBm)	Limit (dBm)	Margin (dB)	Notes
<b>Spurious Harmonic:</b>										
<b>Low Channel:</b>										
3.700	55.6	V	-41.7	2.4	9.5	7.3	-34.6	-13.0	-21.6	
9.250	60.3	V	-25.8	4.2	10.8	8.7	-19.1	-13.0	-6.1	
3.700	49.0	H	-48.1	2.4	9.5	7.3	-41.1	-13.0	-28.1	
9.250	46.0	H	-40.0	4.2	10.8	8.7	-33.4	-13.0	-20.4	
<b>Mid Channel:</b>										
3.760	52.0	V	-45.1	2.5	9.5	7.4	-38.0	-13.0	-25.0	
9.400	56.6	V	-29.5	4.2	11.0	8.9	-22.7	-13.0	-9.7	
3.760	48.0	H	-49.0	2.5	9.5	7.4	-41.9	-13.0	-28.9	
9.400	46.0	H	-40.1	4.2	11.0	8.9	-33.3	-13.0	-20.3	
<b>High Channel:</b>										
3.813	46.7	V	-50.2	2.5	9.5	7.4	-43.1	-13.0	-30.1	
7.640	51.4	V	-37.1	3.8	11.2	9.1	-29.7	-13.0	-16.7	
9.547	48.2	V	-37.9	4.3	11.2	9.1	-30.9	-13.0	-17.9	
3.813	48.0	H	-48.8	2.5	9.5	7.4	-41.8	-13.0	-28.8	
7.640	48.0	H	-39.8	3.8	11.2	9.1	-32.3	-13.0	-19.3	
<b>Note: No other emissions were found up to 20GHz.</b>										

### 8.3. RADIATED EMISSION

#### TEST PERIPHERALS

TEST PERIPHERALS				
Device Type	Manufacturer	Model Number	Serial Number	FCC ID
MODEM	ACEEX	1414	9013537	IFAXDM1414
PRINTER	HP	2225C	2930S52614	DSI6XU2225
MOUSE	HP	M-S34	LZB75200323	D2L211029
LAPTOP	COMPAQ	ARMADA	PP2040	DoC
AC/DC ADAPTOR	COMPAQ	J0024	Z1T9945025261	DoC

#### TEST I/O CABLES

TEST I / O CABLES								
Cable No	I/O Port	# of I/O Port	Connector Type	Type of Cable	Cable Length	Data Traffic	Bundled	Remark
1	Parallel	1	DB25	Shielded	2m	Yes	Yes	N/A
2	Serial	1	DB9	Shielded	1m	Yes	No	N/A
3	KB	1	PS/2	Shielded	2m	Yes	No	N/A
4	Mouse	1	PS/2	Un-shielded	2m	Yes	No	N/A
5	Video	1	DB15	Shielded	2m	Yes	Yes	One Torroid on Each End
6	AC	4	US 115V	Un-shielded	2m	No	No	N/A

#### Detector Setting of Spectrum Analyzer

Frequency Range (MHz)	Detector Function	Resolution Bandwidth	Video Bandwidth
30 to 1000	<input checked="" type="checkbox"/> Peak	<input checked="" type="checkbox"/> 100 KHz	<input checked="" type="checkbox"/> 100 KHz
	<input checked="" type="checkbox"/> Quasi Peak	<input checked="" type="checkbox"/> 1 MHz	<input checked="" type="checkbox"/> 1 MHz

**TEST SETUP**

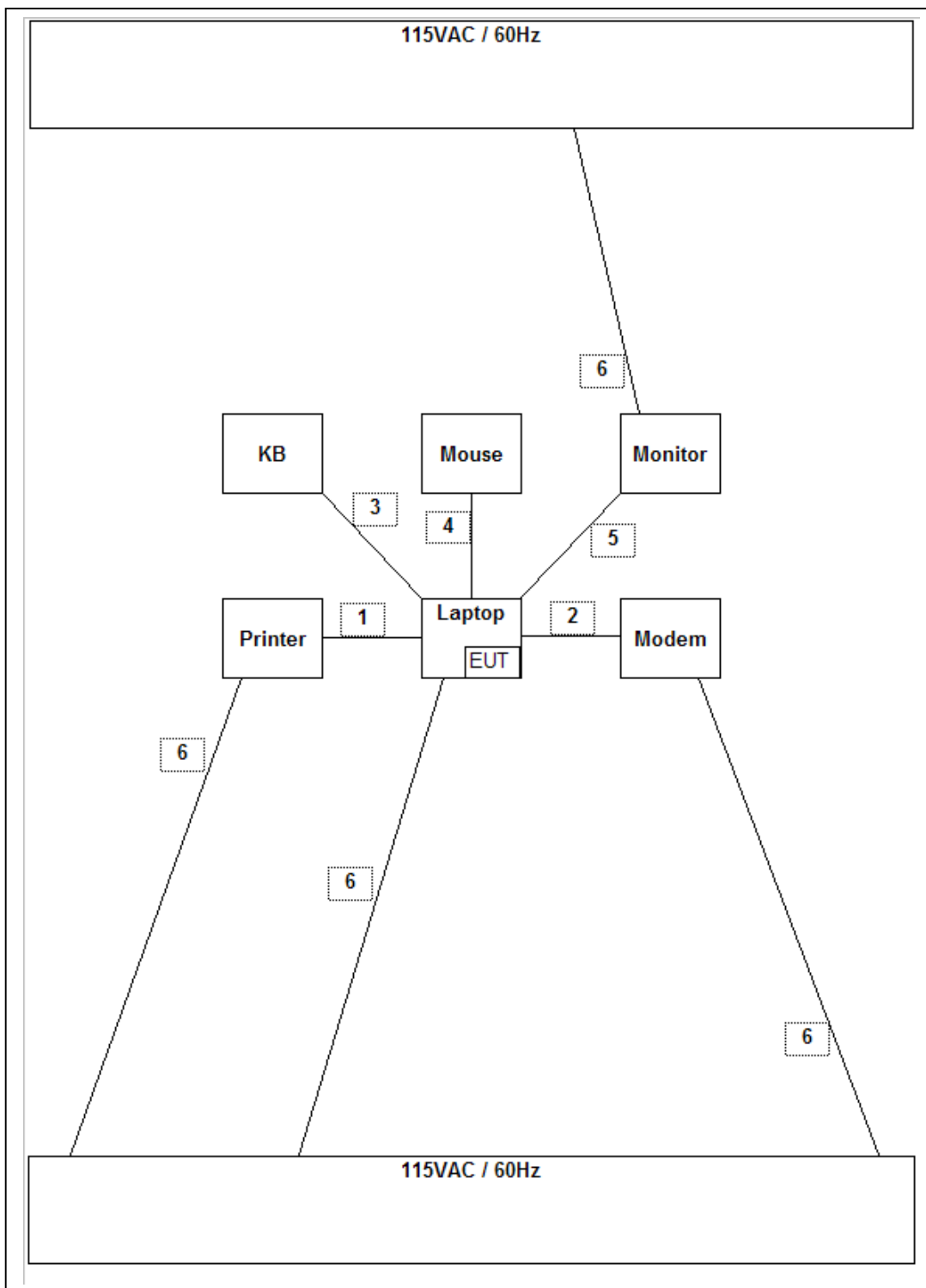

## **TEST PROCEDURE**

1. The EUT was placed on the turn table 0.8 meter above ground inside 3 meter Anechoic Chamber.
2. Set the resolution bandwidth to 120KHz in the test receiver and select Peak function to scan the frequency below 1 GHz.
3. Shift the interference-receiving antenna located in antenna tower upwards and downwards between 1 and 4 meters above ground and find out the local peak emission on frequency domain.
4. Locate the interference-receiving antenna at the position where the local peak reach the maximum emission.
5. Rotate the turn table and stop at the angle where the measurement device has maximum reading
6. Shift the interference-receiving antenna again to detect the maximum emission of the local peak
7. If the reading of the local peak under Peak function is lower than limit by 6dB, then Quasi Peak detection is not needed and this reading should be recorded. And if it is higher than Peak limit, then the test is fail. Others, switch the receiver to Quasi Peak function, set the resolution bandwidth to 100kHz and repeat the procedures (3)~(6). If the reading is lower than limit, this reading should be recorded, otherwise, the test is fail.

## **MEASUREMENT RESULT**

*No non-compliance noted, as shown below.*

**VERTICAL POLARIZATION:**



561F Monterey Road  
 San Jose, CA 95131  
 Tel: (408) 463-0888  
 Fax: (408) 463-0885

Data#: 20 File#: FCC 22.EMI Date: 06-02-2004 Time: 12:10:25

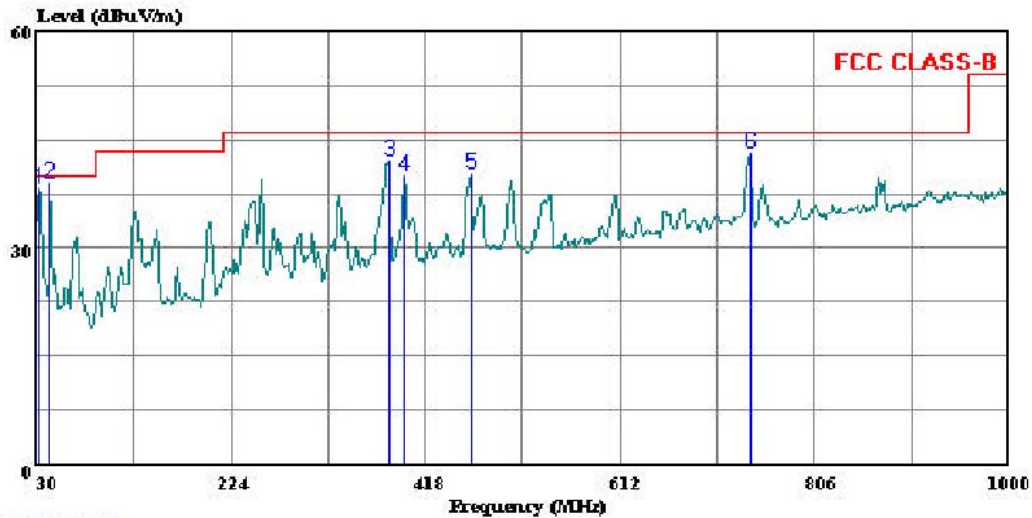

(Auxiliary A TC)

Trace: 16

Ref Trace:

Condition: 3m SUNOL BILOG 12/22/04 VERTICAL  
 Test Operator: Thu Chan  
 Project #: 04U2631-1  
 Company: Sierra Wireless Inc YW  
 EUT: Quad-band 850/900/1800/1900 MHz PC Card  
 Model No: AirCard 775  
 Configuration: EUT/Laptop/Modem/Printer/Mouse  
 Target of Test: FCC Class B  
 Mode of Operation: Standby Mode

Page: 1

	Freq	Remark	Read Level	Factor	Level	Limit	Over
	MHz		dBuV	dB	dBuV/m	dBuV/m	dB
1	31.940	Peak	16.24	22.06	38.30	40.00	-1.70
2	43.580	Peak	25.49	13.58	39.07	40.00	-0.93
3	381.140	Peak	24.38	17.73	42.11	46.00	-3.89
4	397.630	Peak	21.94	18.15	40.09	46.00	-5.91
5	463.590	Peak	20.39	19.78	40.17	46.00	-5.83
6	741.980	Peak	18.80	24.30	43.10	46.00	-2.90

**HORIZONTAL POLARIZATION:**

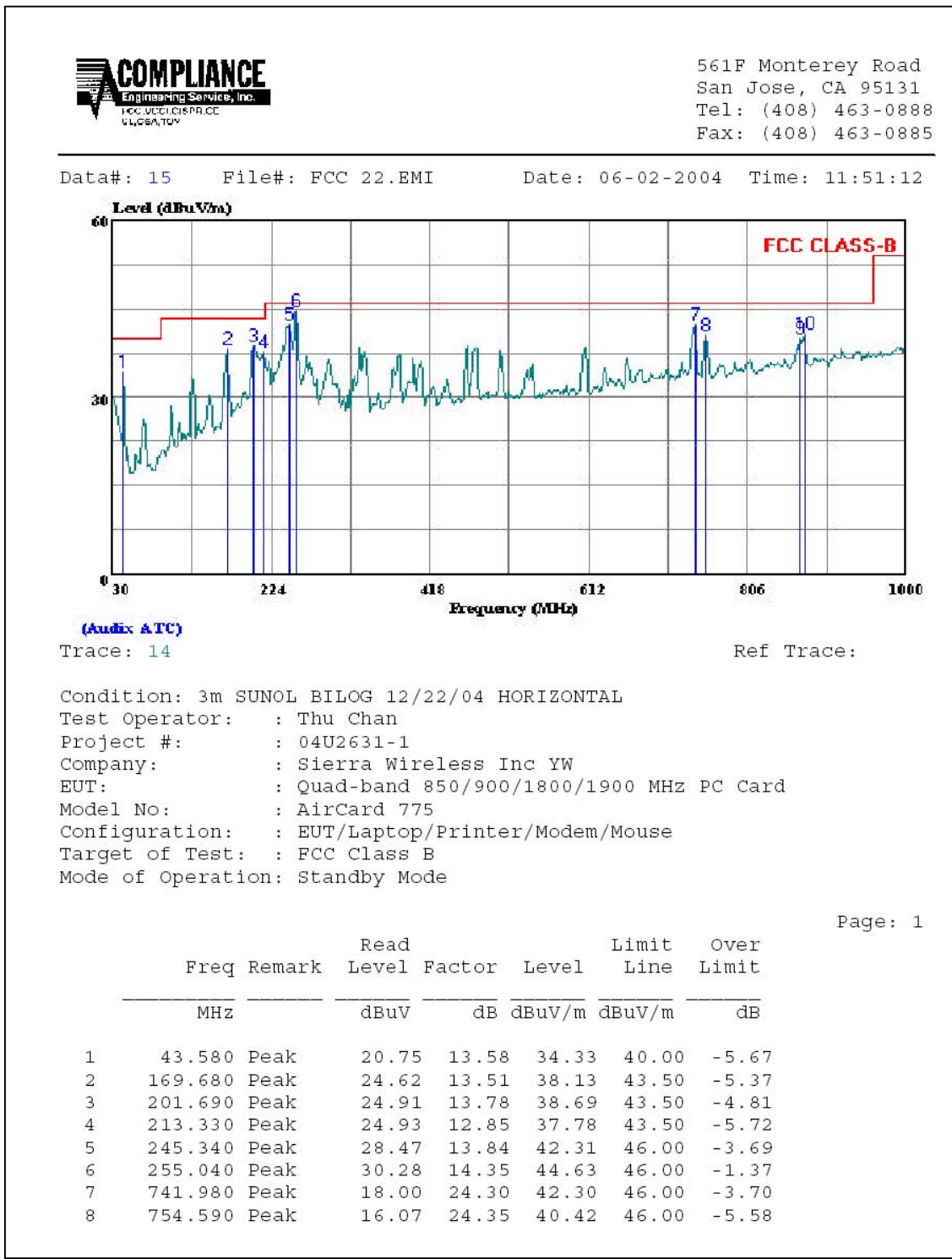

**Radiated Emission photos**





#### 8.4. POWERLINE CONDUCTED EMISSION

Detector Function Setting of Test Receiver

Frequency Range (MHz)	Detector Function	Resolution Bandwidth	Video Bandwidth
150 KHz to 30 MHz	<input checked="" type="checkbox"/> Peak <input type="checkbox"/> CISPR Quasi Peak	<input checked="" type="checkbox"/> 9 KHz	<input checked="" type="checkbox"/> 9 KHz

#### TEST PROCEDURE

1. The EUT was placed on a wooden table 40 cm from a vertical ground plane and approximately 80 cm above the horizontal ground plane on the floor. The EUT was set to transmit in a continuous mode.
2. Line conducted data was recorded for both NEUTRAL and HOT lines.



561F Monterey Road,  
Morgan Hill, CA 95037 USA  
Tel: (408) 463-0885  
Fax: (408) 463-0888

Data#: 7 File#: LC.EMI Date: 06-03-2004 Time: 10:35:35  
Compliance Certification Service

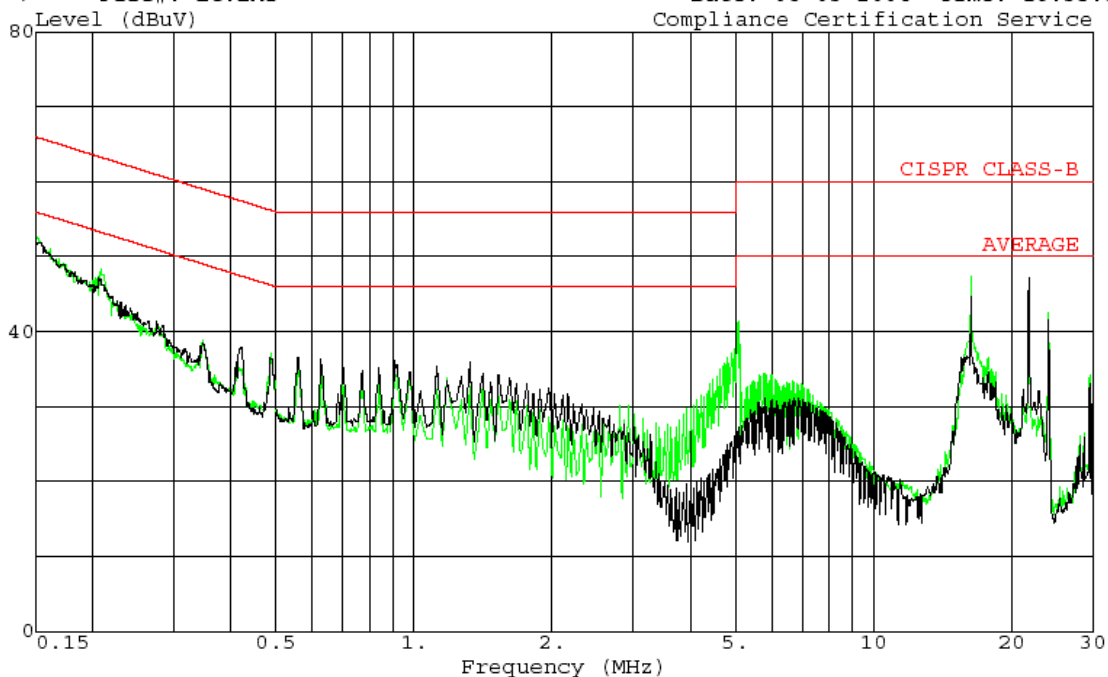

Trace: 3  
Project # : 04U2631-1  
Test Operator : Thu Chan  
Company : Sierra Wireless Inc YW  
EUT : Quad-band 850/900/1800/1900 MHz PC Card  
Model : AirCard 775  
Configuration : EUT/Laptop/Modem/Printer/Mouse  
Mode of Operation: Standby Mode  
Target of Test : FCC Class B  
Voltage : 115VAC / 60 Hz  
Peak: L1(Black) , L2 (Green)

Ref Trace:

**LINE CONDUCTION DATA**

CONDUCTED EMISSIONS DATA (115VAC 60Hz)									
Freq.	Reading			Cclass	Limit	EN_B	Margin		Remark
(MHz)	PK (dBuV)	QP (dBuV)	AV (dBuV)	(dB)	QP	AV	QP (dB)	AV (dB)	L1 / L2
0.15	52.64	--	--	0.00	66.00	56.00	-13.36	-3.36	L1
0.21	47.14	--	--	0.00	64.40	54.40	-17.26	-7.26	L1
21.83	47.30	--	--	0.00	60.00	50.00	-12.70	-2.70	L1
0.15	52.62	--	--	0.00	65.97	55.97	-13.35	-3.35	L2
5.11	41.42	--	--	0.00	60.00	50.00	-18.58	-8.58	L2
16.31	47.40	--	--	0.00	60.00	50.00	-12.60	-2.60	L2
6 Worst Data									

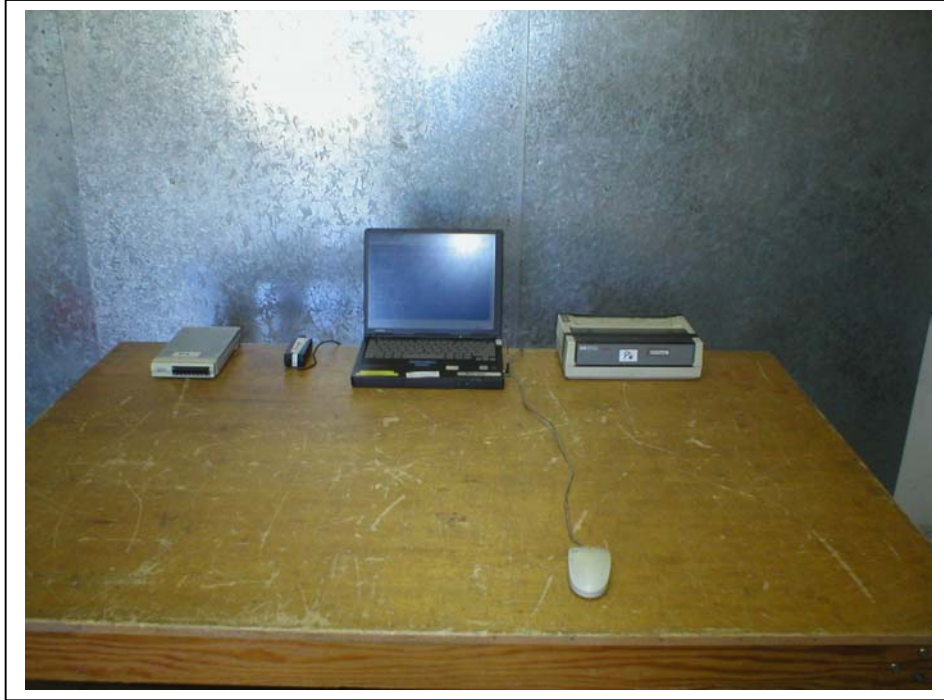

## END OF REPORT

Page 28 of 28