

Test Laboratory: Compliance Certification Services

System Performance Check - D1900V2

DUT: Dipole; Type: D1900V2; Serial: 5d043

Communication System: System Check Signal - CW; Frequency: 1900 MHz; Duty Cycle: 1:1

Medium parameters used: $f = 1900$ MHz; $\sigma = 1.5$ mho/m; $\epsilon_r = 54$; $\rho = 1000$ kg/m³

Phantom section: Flat Section

Room Ambient Temperature: 24.0 deg. C; Liquid Temperature: 23.0 deg. C

DASY4 Configuration:

- Area Scan setting - Find Secondary Maximum Within: 2.0 dB and with a peak SAR value greater than 0.0012W/kg
- Probe: EX3DV4 - SN3686; ConvF(6.85, 6.85, 6.85); Calibrated: 3/23/2009
- Sensor-Surface: 3mm (Mechanical Surface Detection)
- Electronics: DAE3 Sn427; Calibrated: 10/20/2008
- Phantom: Flat Phantom ELI4.0; Type: QDOVA001BA; Serial: SN:XXXX
- Measurement SW: DASY4, V4.7 Build 80; Postprocessing SW: SEMCAD, V1.8 Build 186

d=10mm, Pin=250mW/Area Scan (7x7x1): Measurement grid: dx=15mm, dy=15mm

Maximum value of SAR (measured) = 9.82 mW/g

d=10mm, Pin=250mW/Zoom Scan (7x7x7)/Cube 0: Measurement grid: dx=5mm, dy=5mm, dz=5mm

Reference Value = 91.0 V/m; Power Drift = -0.210 dB

Peak SAR (extrapolated) = 68.6 W/kg

SAR(1 g) = 38.1 mW/g; SAR(10 g) = 20.2 mW/g

Normalized to target power = 1 W and actual power = 0.25 W

Maximum value of SAR (measured) = 47.9 mW/g

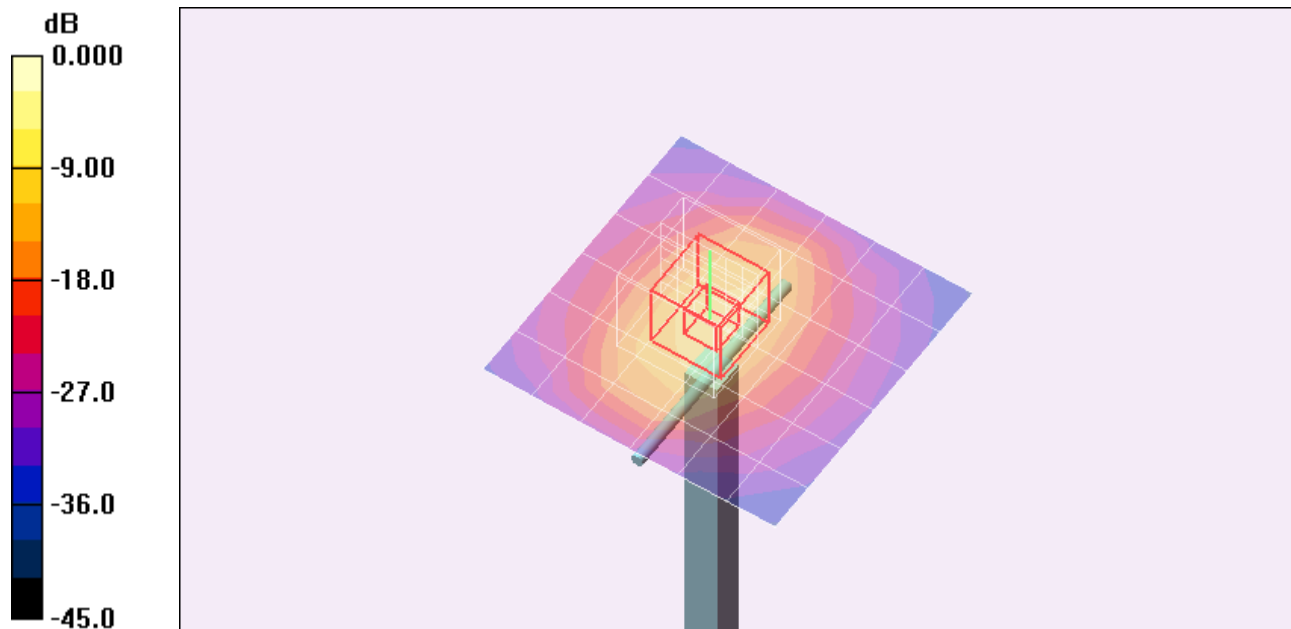

0 dB = 47.9mW/g

Test Laboratory: Compliance Certification Services

System Performance Check - D1900V2

DUT: Dipole; Type: D1900V2; Serial: 5d043

Communication System: System Check Signal - CW; Frequency: 1900 MHz;Duty Cycle: 1:1

d=10mm, Pin=250mW/Z Scan (1x1x34): Measurement grid: dx=20mm, dy=20mm, dz=3mm
Maximum value of SAR (measured) = 11.9 mW/g

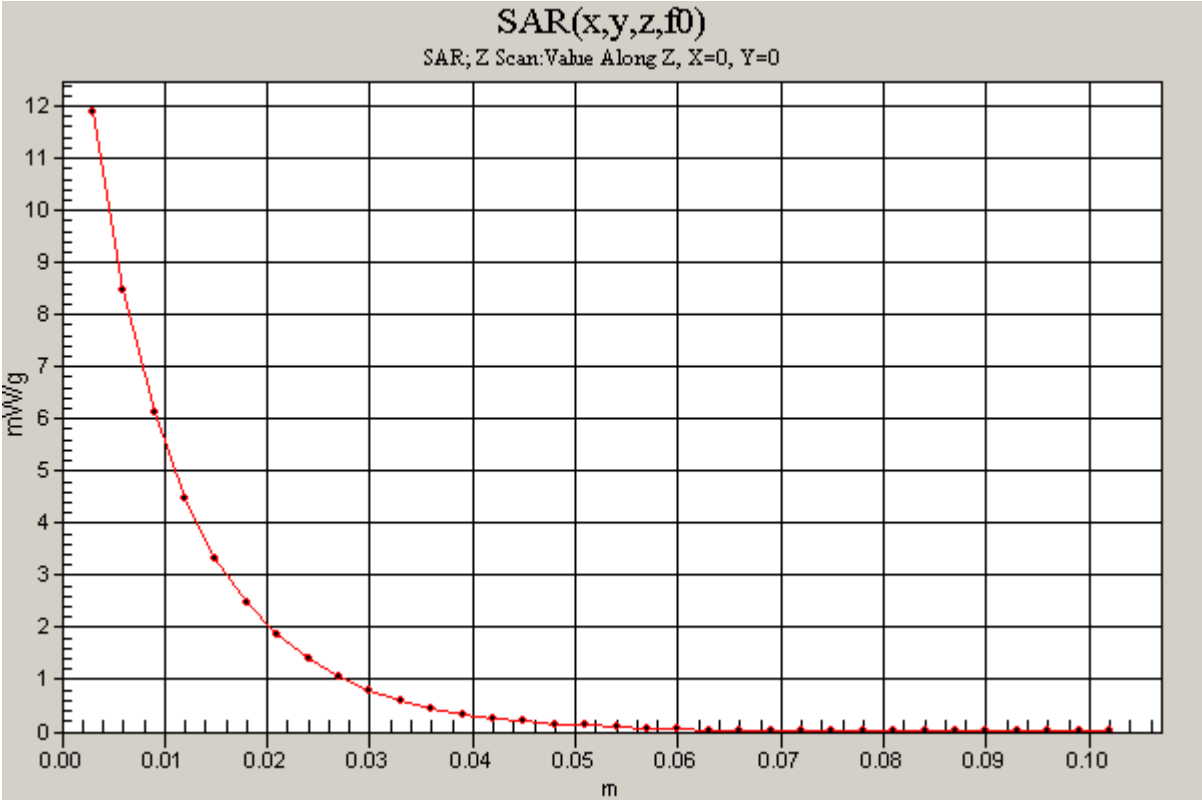

Test Laboratory: Compliance Certification Services

System Performance Check - D1900V2

DUT: Dipole; Type: D1900V2; Serial: 5d043

Communication System: System Check Signal - CW; Frequency: 1900 MHz; Duty Cycle: 1:1

Medium parameters used: $f = 1900$ MHz; $\sigma = 1.5$ mho/m; $\epsilon_r = 53.8$; $\rho = 1000$ kg/m³

Phantom section: Flat Section

Room Ambient Temperature: 24.0 deg. C; Liquid Temperature: 23.0 deg. C

DASY4 Configuration:

- Area Scan setting - Find Secondary Maximum Within: 2.0 dB and with a peak SAR value greater than 0.0012W/kg
- Probe: EX3DV4 - SN3686; ConvF(6.85, 6.85, 6.85); Calibrated: 3/23/2009
- Sensor-Surface: 3mm (Mechanical Surface Detection)
- Electronics: DAE3 Sn500; Calibrated: 9/15/2009
- Phantom: Flat Phantom ELI4.0; Type: QDOVA001BA; Serial: SN:XXXX
- Measurement SW: DASY4, V4.7 Build 80; Postprocessing SW: SEMCAD, V1.8 Build 186

d=10mm, Pin=250mW/Area Scan (7x7x1): Measurement grid: dx=15mm, dy=15mm

Maximum value of SAR (measured) = 9.81 mW/g

d=10mm, Pin=250mW/Zoom Scan (7x7x7)/Cube 0: Measurement grid: dx=5mm, dy=5mm, dz=5mm

Reference Value = 91.1 V/m; Power Drift = -0.140 dB

Peak SAR (extrapolated) = 68.3 W/kg

SAR(1 g) = 37.9 mW/g; SAR(10 g) = 20 mW/g

Normalized to target power = 1 W and actual power = 0.25 W

Maximum value of SAR (measured) = 48.1 mW/g

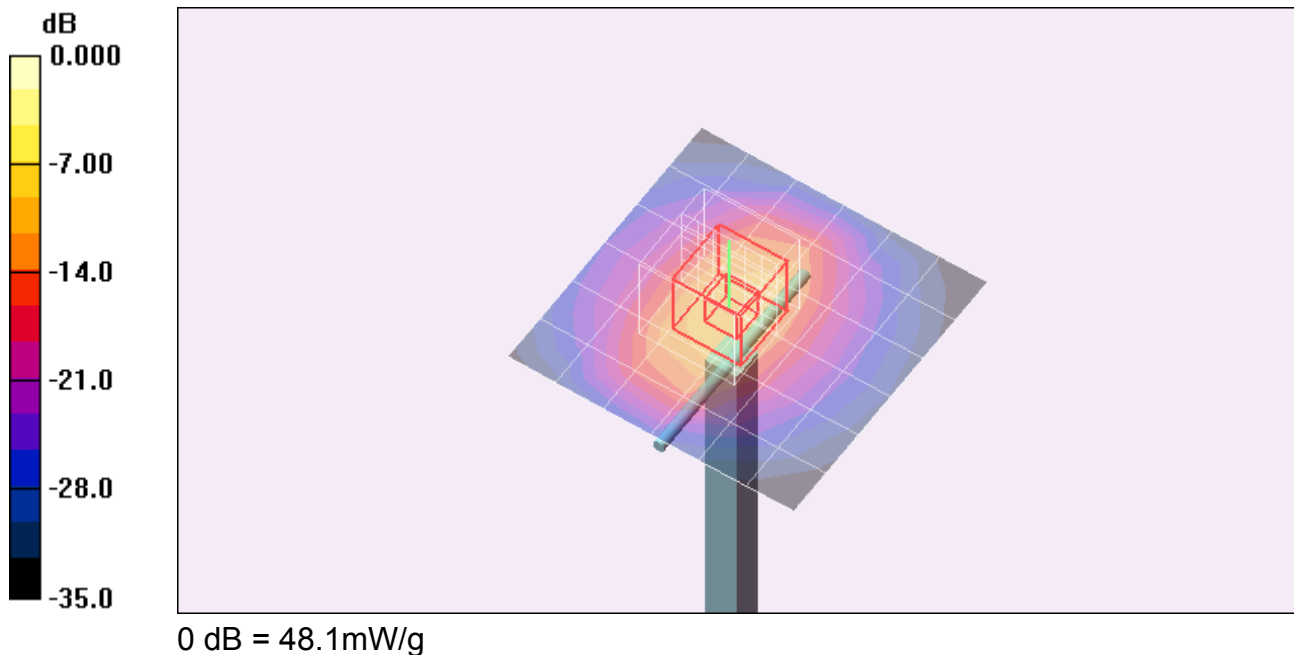

Test Laboratory: Compliance Certification Services

System Performance Check - D1900V2

DUT: Dipole; Type: D1900V2; Serial: 5d043

Communication System: System Check Signal - CW; Frequency: 1900 MHz; Duty Cycle: 1:1

d=10mm, Pin=250mW/Z Scan (1x1x34): Measurement grid: dx=20mm, dy=20mm, dz=3mm
Maximum value of SAR (measured) = 12 mW/g

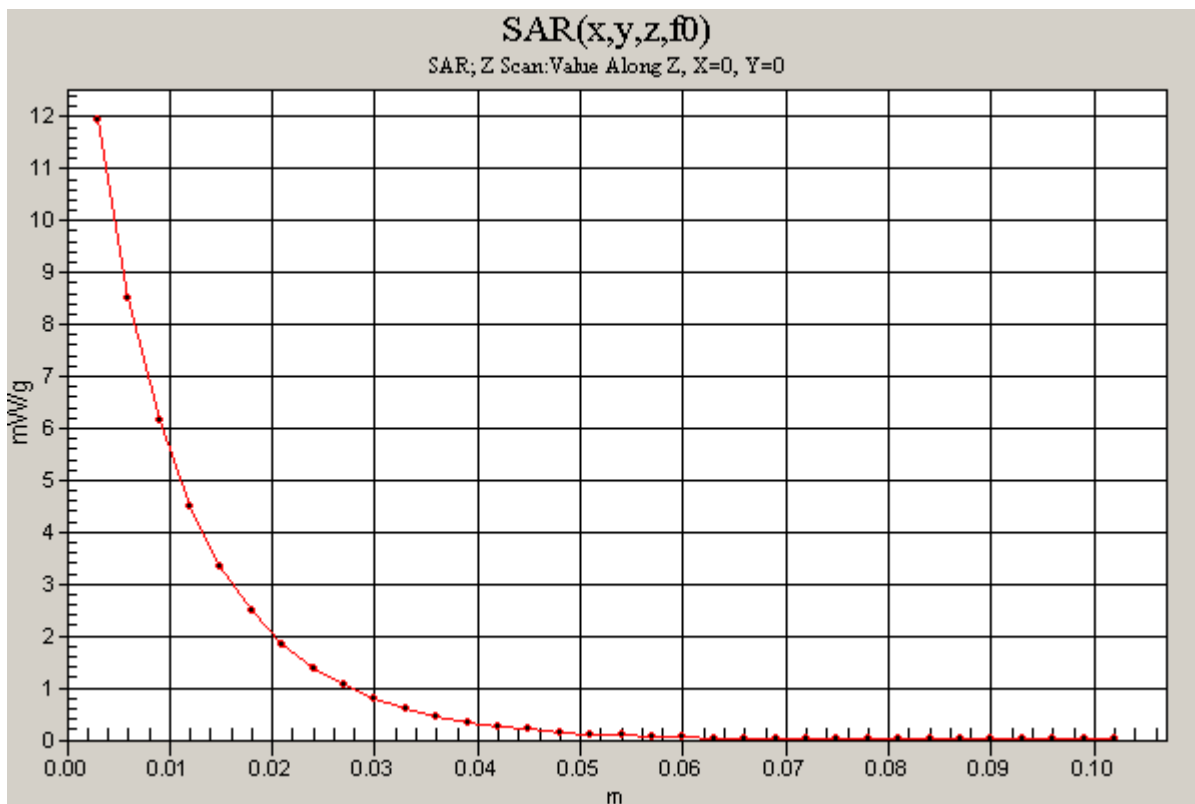

Test Laboratory: Compliance Certification Services

System Performance Check - D835V2

DUT: Dipole; Type: D835V2; Serial: 4d002

Communication System: System Check Signal - CW; Frequency: 835 MHz; Duty Cycle: 1:1

Medium parameters used: $f = 835$ MHz; $\sigma = 0.968$ mho/m; $\epsilon_r = 53.7$; $\rho = 1000$ kg/m³

Phantom section: Flat Section

Room Ambient Temperature: 24.0 deg. C; Liquid Temperature: 23.0 deg. C

DASY4 Configuration:

- Area Scan setting - Find Secondary Maximum Within: 2.0 dB and with a peak SAR value greater than 0.0012W/kg
- Probe: EX3DV4 - SN3686; ConvF(8.7, 8.7, 8.7); Calibrated: 3/23/2009
- Sensor-Surface: 3mm (Mechanical Surface Detection)
- Electronics: DAE3 Sn427; Calibrated: 10/20/2008
- Phantom: Flat Phantom ELI4.0; Type: QDOVA001BA; Serial: SN:1003
- Measurement SW: DASY4, V4.7 Build 80; Postprocessing SW: SEMCAD, V1.8 Build 186

d=15mm, Pin=250mW/Area Scan (7x9x1): Measurement grid: dx=15mm, dy=15mm

Maximum value of SAR (measured) = 2.94 mW/g

d=15mm, Pin=250mW/Zoom Scan (7x7x7)/Cube 0: Measurement grid: dx=5mm, dy=5mm, dz=5mm

Reference Value = 55.2 V/m; Power Drift = -0.021 dB

Peak SAR (extrapolated) = 15.0 W/kg

SAR(1 g) = 10.1 mW/g; SAR(10 g) = 6.58 mW/g

Normalized to target power = 1 W and actual power = 0.25 W

Maximum value of SAR (measured) = 11.8 mW/g

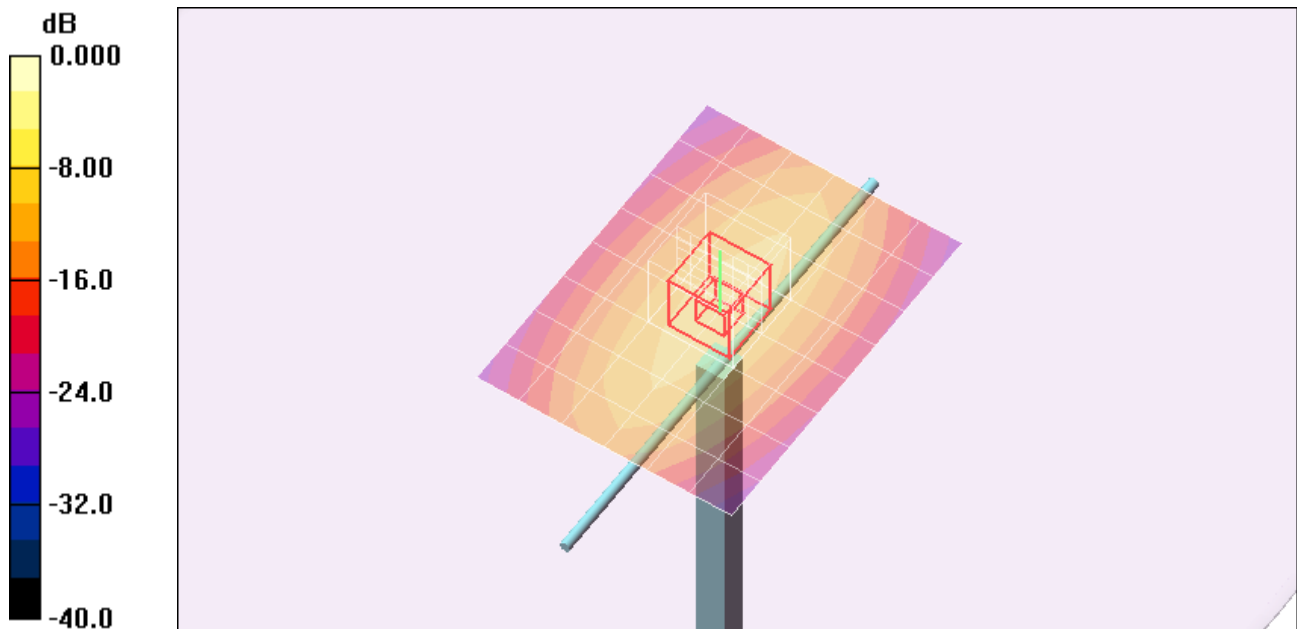

0 dB = 11.8mW/g

Test Laboratory: Compliance Certification Services

System Performance Check - D835V2

DUT: Dipole; Type: D835V2; Serial: 4d002

Communication System: System Check Signal - CW; Frequency: 835 MHz; Duty Cycle: 1:1

d=15mm, Pin=250mW/Z Scan (1x1x34): Measurement grid: dx=20mm, dy=20mm, dz=3mm
Maximum value of SAR (measured) = 2.95 mW/g

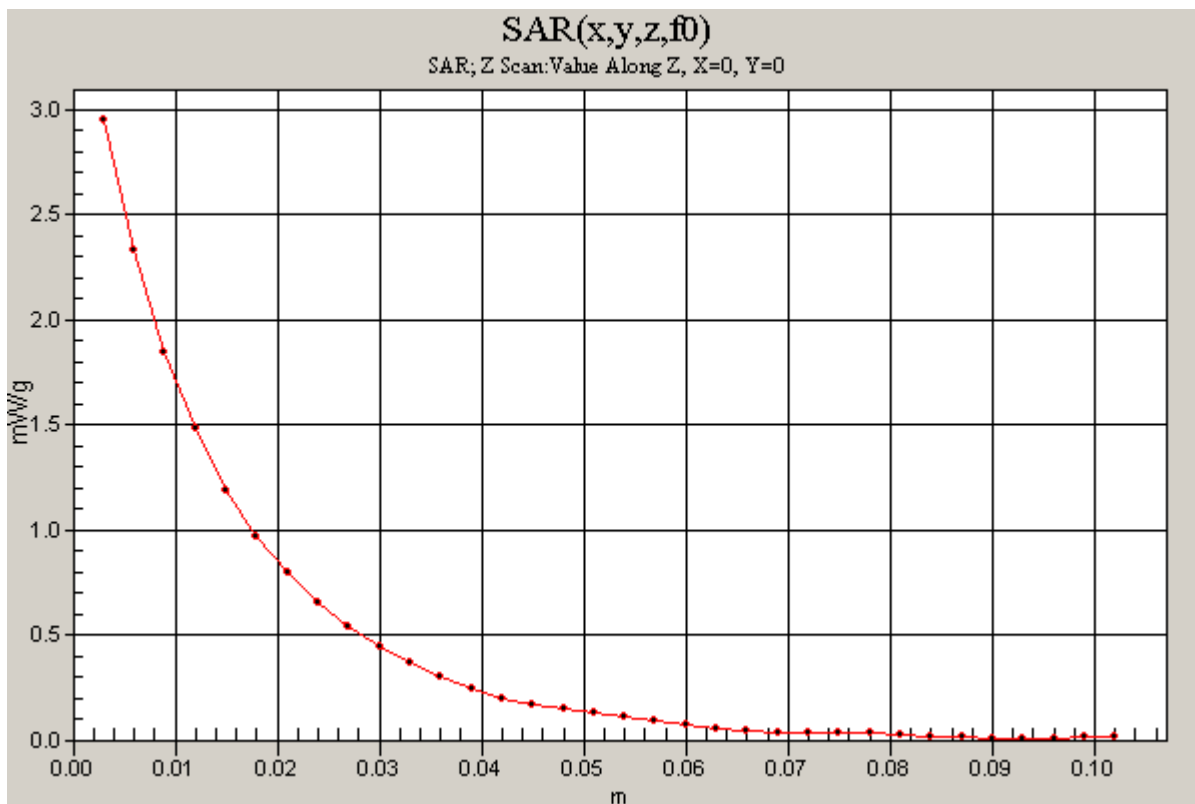

Test Laboratory: Compliance Certification Services

System Performance Check - D835V2

DUT: Dipole; Type: D835V2; Serial: 4d002

Communication System: System Check Signal - CW; Frequency: 835 MHz; Duty Cycle: 1:1

Medium parameters used: $f = 835$ MHz; $\sigma = 0.969$ mho/m; $\epsilon_r = 53.9$; $\rho = 1000$ kg/m³

Phantom section: Flat Section

Room Ambient Temperature: 24.0 deg. C; Liquid Temperature: 23.0 deg. C

DASY4 Configuration:

- Area Scan setting - Find Secondary Maximum Within: 2.0 dB and with a peak SAR value greater than 0.0012W/kg
- Probe: EX3DV4 - SN3686; ConvF(8.7, 8.7, 8.7); Calibrated: 3/23/2009
- Sensor-Surface: 3mm (Mechanical Surface Detection)
- Electronics: DAE3 Sn500; Calibrated: 9/15/2009
- Phantom: Flat Phantom ELI4.0; Type: QDOVA001BA; Serial: SN:1003
- Measurement SW: DASY4, V4.7 Build 80; Postprocessing SW: SEMCAD, V1.8 Build 186

d=15mm, Pin=250mW/Area Scan (7x9x1): Measurement grid: dx=15mm, dy=15mm

Maximum value of SAR (measured) = 2.96 mW/g

d=15mm, Pin=250mW/Zoom Scan (7x7x7)/Cube 0: Measurement grid: dx=5mm, dy=5mm, dz=5mm

Reference Value = 55.4 V/m; Power Drift = -0.013 dB

Peak SAR (extrapolated) = 15.2 W/kg

SAR(1 g) = 10.2 mW/g; SAR(10 g) = 6.63 mW/g

Normalized to target power = 1 W and actual power = 0.25 W

Maximum value of SAR (measured) = 11.9 mW/g

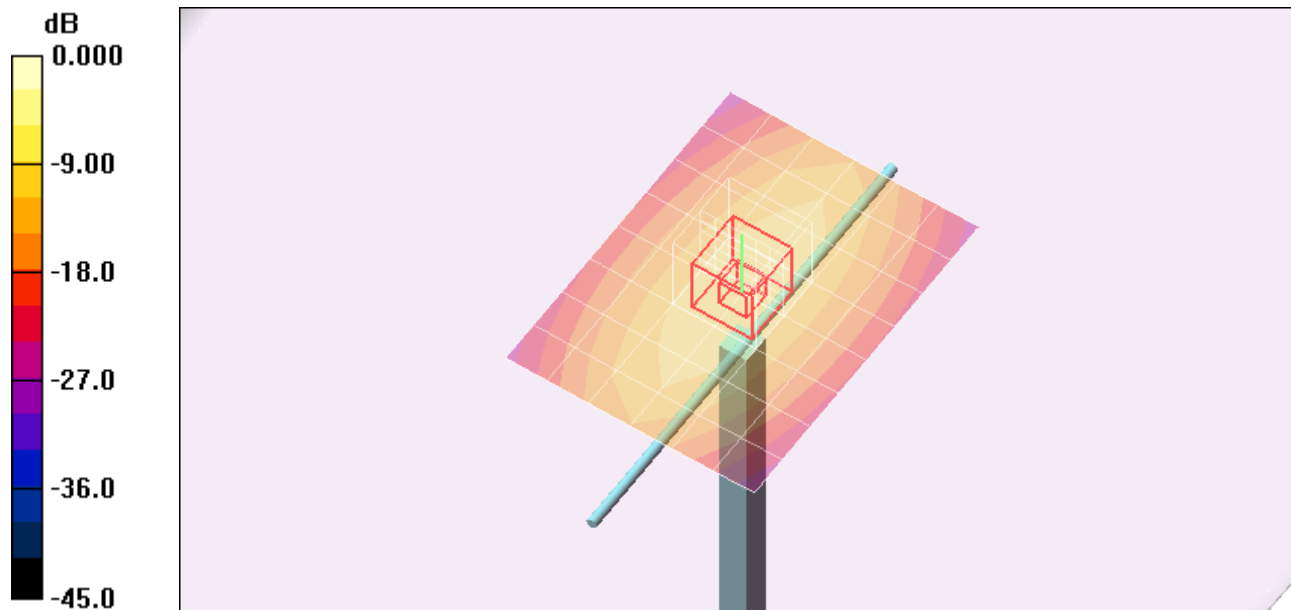

0 dB = 11.9mW/g

Test Laboratory: Compliance Certification Services

System Performance Check - D835V2

DUT: Dipole; Type: D835V2; Serial: 4d002

Communication System: System Check Signal - CW; Frequency: 835 MHz;Duty Cycle: 1:1

d=15mm, Pin=250mW/Z Scan (1x1x34): Measurement grid: dx=20mm, dy=20mm, dz=3mm
Maximum value of SAR (measured) = 2.96 mW/g

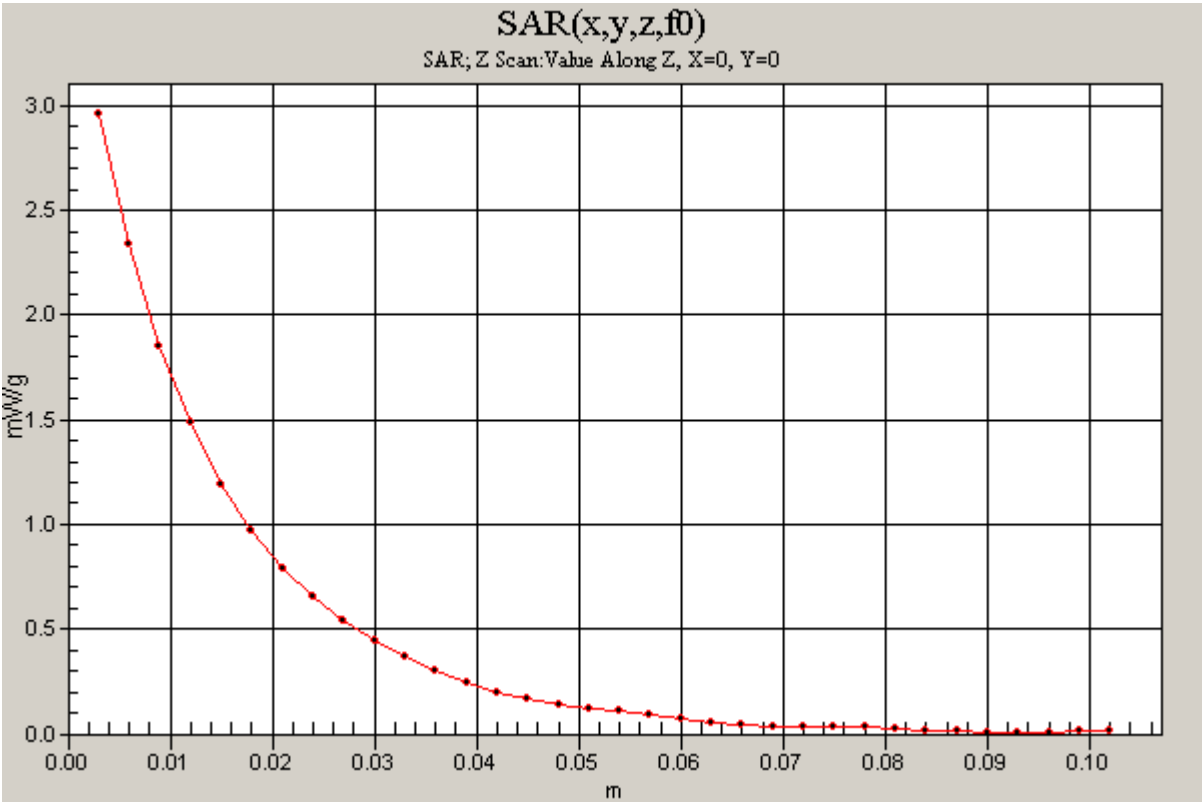

Test Laboratory: Compliance Certification Services

System Performance Check - D2000V2

DUT: Dipole 2000 MHz; Type: D2000V2; Serial: SN: 1016

Communication System: System Check Signal - CW; Frequency: 2000 MHz; Duty Cycle: 1:1

Medium parameters used: $f = 2000$ MHz; $\sigma = 1.56$ mho/m; $\epsilon_r = 53.3$; $\rho = 1000$ kg/m³

Phantom section: Flat Section

Room Ambient Temperature: 24.0 deg. C; Liquid Temperature: 23.0 deg. C

DASY4 Configuration:

- Area Scan setting - Find Secondary Maximum Within: 2.0 dB and with a peak SAR value greater than 0.0012W/kg
- Probe: EX3DV4 - SN3686; ConvF(6.94, 6.94, 6.94); Calibrated: 3/23/2009
- Sensor-Surface: 3mm (Mechanical Surface Detection)
- Electronics: DAE3 Sn427; Calibrated: 10/20/2008
- Phantom: Flat Phantom ELI4.0; Type: QDOVA001BA; Serial: SN:1003
- Measurement SW: DASY4, V4.7 Build 80; Postprocessing SW: SEMCAD, V1.8 Build 186

d=10mm, Pin=250mW/Area Scan (7x7x1): Measurement grid: dx=15mm, dy=15mm

Maximum value of SAR (measured) = 9.99 mW/g

d=10mm, Pin=250mW/Zoom Scan (7x7x7)/Cube 0: Measurement grid: dx=5mm, dy=5mm, dz=5mm

Reference Value = 89.9 V/m; Power Drift = -0.020 dB

Peak SAR (extrapolated) = 71.8 W/kg

SAR(1 g) = 39.5 mW/g; SAR(10 g) = 20.7 mW/g

Normalized to target power = 1 W and actual power = 0.25 W

Maximum value of SAR (measured) = 50.1 mW/g

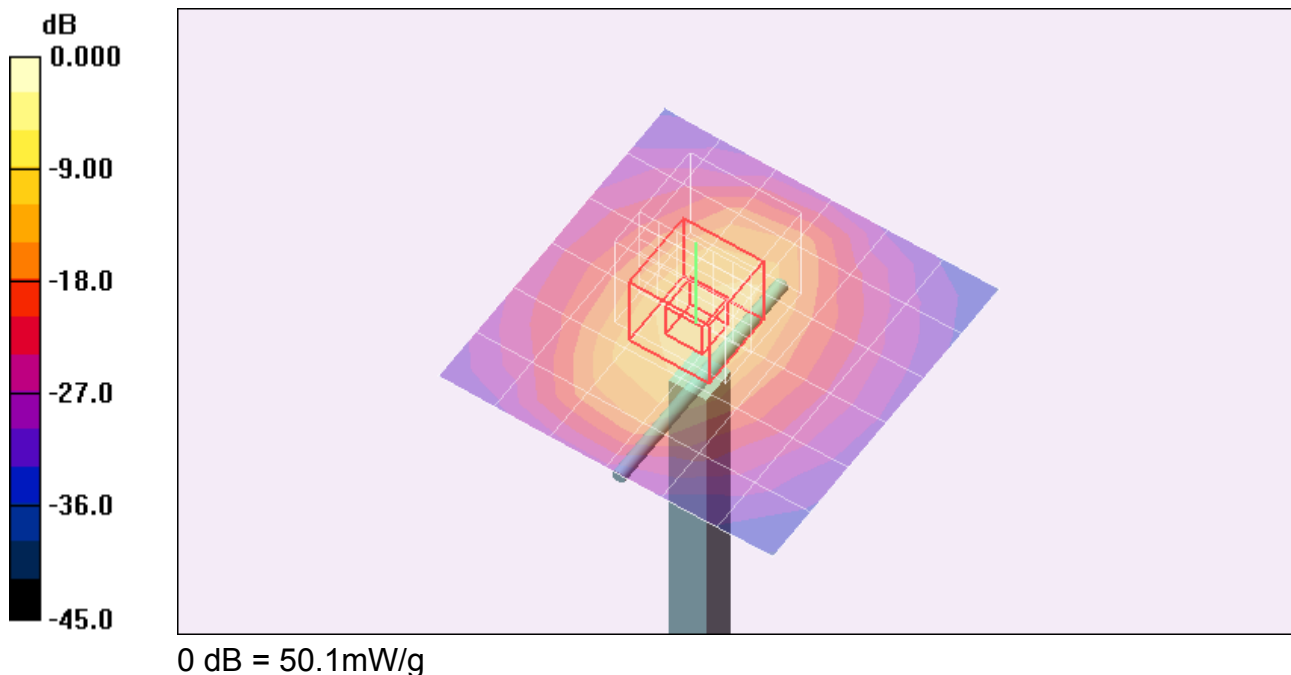

Test Laboratory: Compliance Certification Services

System Performance Check - D2000V2

DUT: Dipole 2000 MHz; Type: D2000V2; Serial: SN: 1016

Communication System: System Check Signal - CW; Frequency: 2000 MHz; Duty Cycle: 1:1

d=10mm, Pin=250mW/Z Scan (1x1x34): Measurement grid: dx=20mm, dy=20mm, dz=3mm
Maximum value of SAR (measured) = 12.6 mW/g

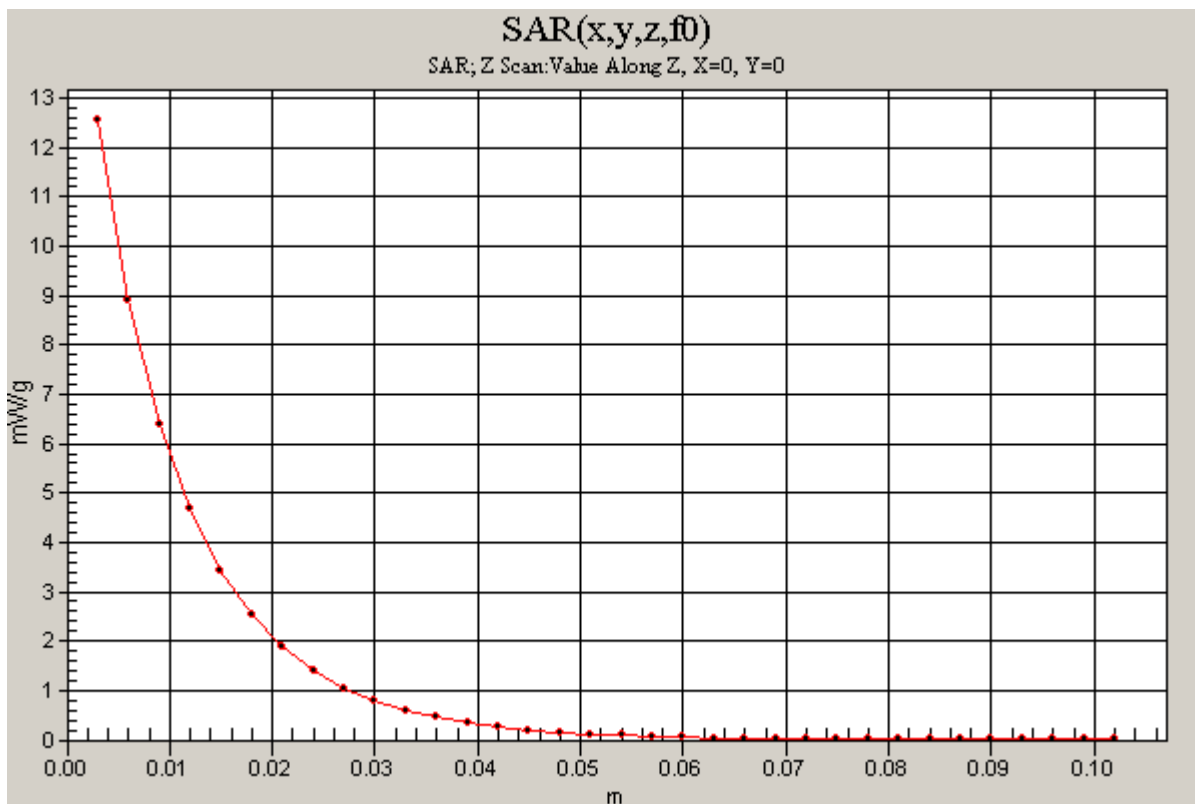

Test Laboratory: Compliance Certification Services

System Performance Check - D2000V2

DUT: Dipole 2000 MHz; Type: D2000V2; Serial: SN: 1016

Communication System: System Check Signal - CW; Frequency: 2000 MHz; Duty Cycle: 1:1

Medium parameters used: $f = 2000$ MHz; $\sigma = 1.55$ mho/m; $\epsilon_r = 53.2$; $\rho = 1000$ kg/m³

Phantom section: Flat Section

Room Ambient Temperature: 24.0 deg. C; Liquid Temperature: 23.0 deg. C

DASY4 Configuration:

- Area Scan setting - Find Secondary Maximum Within: 2.0 dB and with a peak SAR value greater than 0.0012W/kg
- Probe: EX3DV4 - SN3686; ConvF(6.94, 6.94, 6.94); Calibrated: 3/23/2009
- Sensor-Surface: 3mm (Mechanical Surface Detection)
- Electronics: DAE3 Sn500; Calibrated: 9/15/2009
- Phantom: Flat Phantom ELI4.0; Type: QDOVA001BA; Serial: SN:1003
- Measurement SW: DASY4, V4.7 Build 80; Postprocessing SW: SEMCAD, V1.8 Build 186

d=10mm, Pin=250mW/Area Scan (7x7x1): Measurement grid: dx=15mm, dy=15mm

Maximum value of SAR (measured) = 9.96 mW/g

d=10mm, Pin=250mW/Zoom Scan (7x7x7)/Cube 0: Measurement grid: dx=5mm, dy=5mm, dz=5mm

Reference Value = 90.0 V/m; Power Drift = -0.025 dB

Peak SAR (extrapolated) = 71.6 W/kg

SAR(1 g) = 39.6 mW/g; SAR(10 g) = 20.8 mW/g

Normalized to target power = 1 W and actual power = 0.25 W

Maximum value of SAR (measured) = 50.0 mW/g

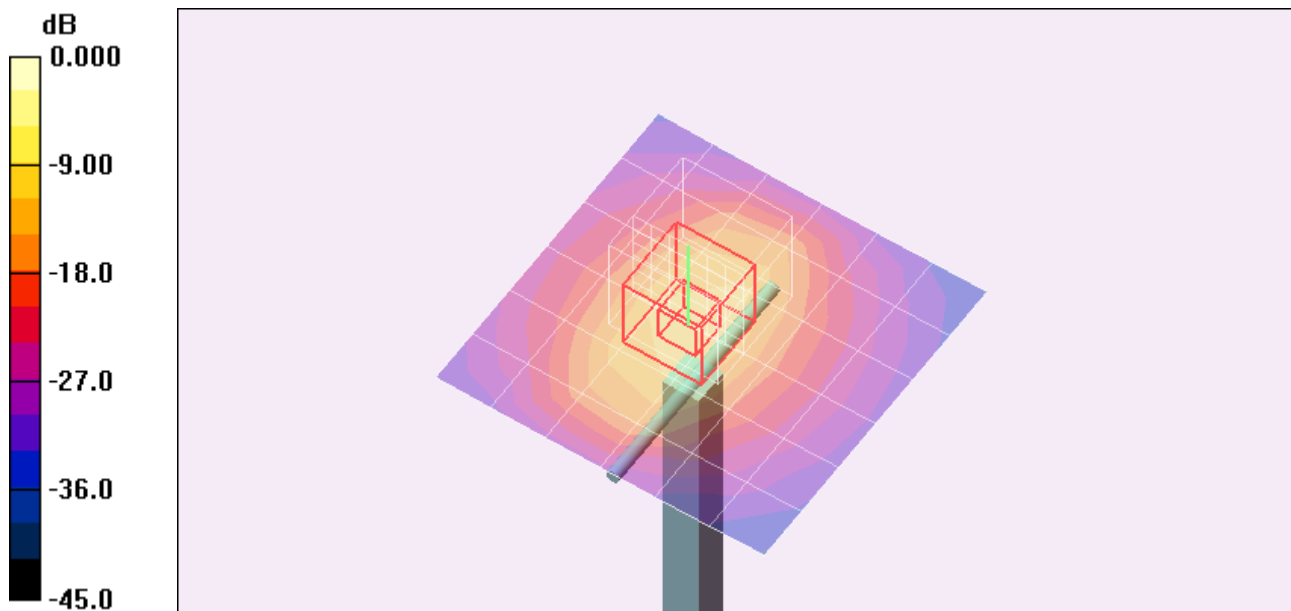

0 dB = 50.0mW/g

Test Laboratory: Compliance Certification Services

System Performance Check - D2000V2

DUT: Dipole 2000 MHz; Type: D2000V2; Serial: SN: 1016

Communication System: System Check Signal - CW; Frequency: 2000 MHz;Duty Cycle: 1:1

d=10mm, Pin=250mW/Z Scan (1x1x34): Measurement grid: dx=20mm, dy=20mm, dz=3mm
Maximum value of SAR (measured) = 12.5 mW/g

