

User Guide to

CNI-903 M

(Radio Packet Modem)

CNI Inc.

1. Overview	3
2. Specification and features	3
A.Environment	3
B.General RF specifications	3
C.Radio interface	4
D.Transmitter	4
E.Receiver	4
3. Circuit guide	5
4. Installation Guide	9
Modem Description	9
Design Consideration	13
Installation	14
Warning Label	15
Antenna Specificaqtion	21

1. Overview

CNI-903M, RPM3(Radio Packet Modem), is a digital data communication equipment in accordance with Mobitex specification. The frequency it uses ranges from 896Mhz to 902Mhz for transmission and from 935MHz to 941MHz for reception.

This modem enables you to make data communication in two-way, and it also helps you to enjoy various types of data services with full mobility due to support for roaming.

With 'Interface Connector' you can apply this modem to many kinds of machines to use 'Mobitex Asynchronous Serial Communication (MASC)' protocol for communication. And it enables you to monitor the operation during communication.

- Basic specification

- Dimension : 47 × 70 × 9mm
- Weight : 37 g
- Supply voltage : 5.0V ± 10%
- Protocol : Mobitex
- Host protocol : MASC

2. Specification and features

A. Environment

- Normal operational temperature : +15°C ~ +35°C
- Extreme operation temperature : -25°C ~ +55°C
- Storage temperature : -40°C ~ +70°C
- Humidity : Withstand 20 ~ 70% RH.

B. General RF specifications

- Method of Modulation : GMSK
- Modulation frequency shift
 - 2.0KHz ± 0.1KHz (Logic '1')
 - 2.0KHz ± 0.1KHz (Logic '0')
- Transmission mode : Half-duplex
- Data transmission speed : 8,000bps

C. Radio interface

- Channel spacing : 12.5KHz
- Bandwidth : less than 10KHz

D. Transmitter

- Frequency : 896 ~ 902 MHz
- Transmit power (MAX Power : 2W)
- Frequency stability : $\pm 1.5\text{ppm}$ ($-25^{\circ}\text{C} \sim +55^{\circ}\text{C}$)
- Modulation stability : $\pm 5\%$
- Harmonic and Spurious Emission : -56dBc(Portable)
 -60dBc(Mobile)
- Output Power in carrier off : $0.25\mu\text{ W}$ (-36dBm)
- Spurious RF Radiation Carrier Off
 - : -60dBm (896 ~ 902MHz band)
 - : -80dBm (935 ~ 941MHz band)

E. Receiver

- Frequency : 935 ~ 941MHz
- Sensitivity : -115 dBm (BLER < 10%)
- Adjacent Channel Rejection : > 55dB
- Out-of-Band Rejection ($f_0 \pm 1$ to 10MHz) : > 60dBc
- Image frequency rejection : > 45dBc

3. Circuit guide

A. RF circuit

CNI-903M circuit consists of five parts, each of which is power supply, antenna, synthesis / modulation of frequency, transmission and reception.

① Power supply

Power supply is composed of voltage regulator and switching part. Voltage regulator generates 3V of power supplied from VBB when the control of RF_EN switch is turned on.

When RF_EN is high, RF_VCC is regulated with 3V, and RF_VCC is supplied to PLL IC, VCTCXO, OP-Amp(IC102), VCO, and Buffer Amp(Q104).

When RX_EN is low, RX_VCC is turned on by Q107, and RX_VCC (3V) is supplied to LNA, MIXER, IF AMP and IF IC.

When TX_EN is low, TX_VCC is turned on by Q106, and TX_VCC (3V) is supplied to Drive Amp(Q105) and OP-Amp(IC104).

The switch between TX mode and RX mode can be achieved by control of RX_EN(Q107) and TX_EN(Q106).

② Antenna

Antenna part is composed of antenna matching circuit, BPF, and RX/TX signal isolation circuit.

CNI-903M adapts $\lambda / 4$ WHIP antenna to match to mid range frequency of communication.

TX/RX signal isolation circuit isolates signals of communication and is composed with switching diode and inductor.

The signals received from antenna meet the send/receive path and then D101 is turned on and the signals proceed only to receiving path. In transmitting mode, signals from TX Power Amp can not go through RX path because D101 is off. (refer to RF circuit diagram)

③ Frequency synthesizer and modulator

Frequency synthesizer consists of PLL part, VCO module and pre-modulation filter. The PLL part is composed of phase detector, loop filter, and 12.6Mhz VCTCXO

VCO module generates 896~902Mhz frequencies in accordance with the voltage which is from charge pump of PLL to loop filter. Programmable Divider in PLL makes the VCO output frequency to any channel value according to the frequency data from Logic CPU. Phase detector gets low and high frequencies from comparison of phase. Loop filter filters the frequencies to get a value of voltage. The voltage is input to VCO to achieve phase lock process.

Modulation is completed when modem IC signal of Logic part is input to VCO and authorized.

④ Receiver

Receiver filters and amplifies RF signal through SAW filter and LNA.

RX part is double super heterodyne type, and consists of LNA, LPF, Mixer, SAW filter and IF IC part. There happens RX signal from antenna and the signal is low-noise-amplification(LNA) through SAW filter and LNA, and it comes to 2nd IF 455KHz via 2nd X-TAL(39.545MHz).

SAW filter rejects Image frequency($f_c \pm 2*IF$) generated from 1'st Mixer while receiving. For example, if the input channel is 939MHz, the output frequency would be 40MHz from mixer while local frequency is 899MHz. But if SAW filter will not filter the image frequency of $939 \pm 2*IF$, S/N would be worse with 40MHz($899-859=40$) of noise. And SAW filter should filter to prevent local frequency becoming spurious through LNA and reverse path.

LNA amplifies and sends the faint signal from antenna to mixer, and mixer TR mixes and generates 1st IF with frequency from antenna.

IF comes from mixer. And IF contains inter-modulation product component. MCF removes that product component. So clean IF(40MHz) can be inserted to IF IC. 2nd local frequency entered IF IC is mixed with the IF(40MHz) signal to be 2nd IF of

455KHz simultaneously.

2nd IF signal of 455KHz passes LPF(Ceramic filter) to remove the noise, and the signal is de-modulated with discriminator method. Here detected RF signal entered into receiver and RSSI signal which indicates the strength, and they are passed to micro processor in analogue value.

⑤ Transmitter

Transmitter consists of driver amp and power amplifier, and TX power control. It generates carrier frequency while share RX with frequency synthesizer.

Local frequency is used to direct transmission frequency because there is difference between transmission and reception. So it only amplifies and propagates through PA(Power Amp.) which can get high level of gain easily with low power.

B. LOGIC Circuit

① Summary

This unit consists of CPU part, Memory part, modem part, and power supply part.

② CPU part(IC2)

The CPU adopted by this unit has 16/32-bit ARM7TDMI RISC processor (66MHz) and works on 4MHz. The main functions are as follows;

- Execute MASC protocol
- Control PLL circuit of RF part and perform Power Saving function
- Perform Data transaction function(receiving and transmitting) through Data Pump(Modem)part
- Checking and processing of RSSI Level come from RF part
- Perform Data transaction with DTE through DTE interface part

③ Memory part (IC1, IC3)

Memory part consists of FLASH Memory (2Mb, IC1) and SRAM(1Mb, IC3). Flash Memory stores MSN information and program. And SRAM supplies memory stacks for program.

④ Modem Data Pump (IC7)

Modem part is in charge of MASC protocol , and transmits two way Data between CPU and RF part. The main functions are as followings ;

- Packet Data Framing
- GMSK Data Modulation
- FEC Encoding/Decoding
- Interleaving/De-interleaving

2. Pin Assignments of CNI-903M

This unit can be easily integrated into anywhere of the wireless modem adopted device.

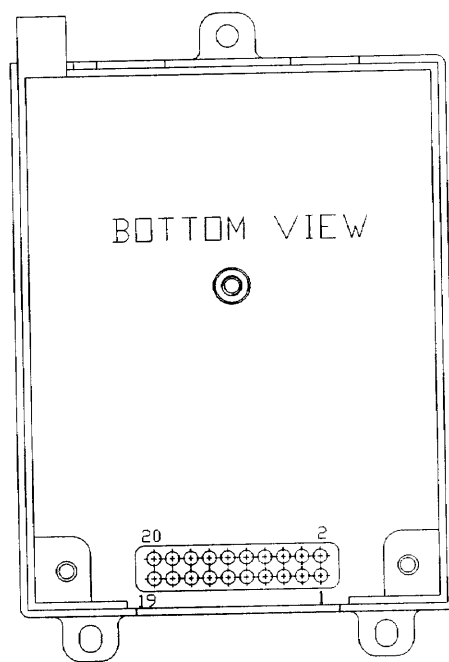

PIN ASSIGNMENTS

1. GND	: Ground to Host
2. RXAUDIO	: Rx Audio
3. GND	: Ground to Host
4. RTS	: Ready to send
5. DSR	: Data Set Ready
6. CTS	: Clear To Send
7. RI	: Ring Indicator
8. DTR	: Data Transmit Ready
9. INEANGE	: In Range Indicator
10. ONI	: On Indicator
11. SENSE1	: SENSE1
12. MSG	: Message Waiting
13. SENSE3	: SENSE3
14. SENSE2	: SENSE2
15. TXD	: Transmit Data
16. RESET	: RESET
17. VBB	: 4.2V Power Supply
18. RXD	: Receive Data
19. VBB	: 4.2V Power Supply
20. TXIND	: Transmit Indicator

INTERFACE CIRCUIT OF CNI-903M

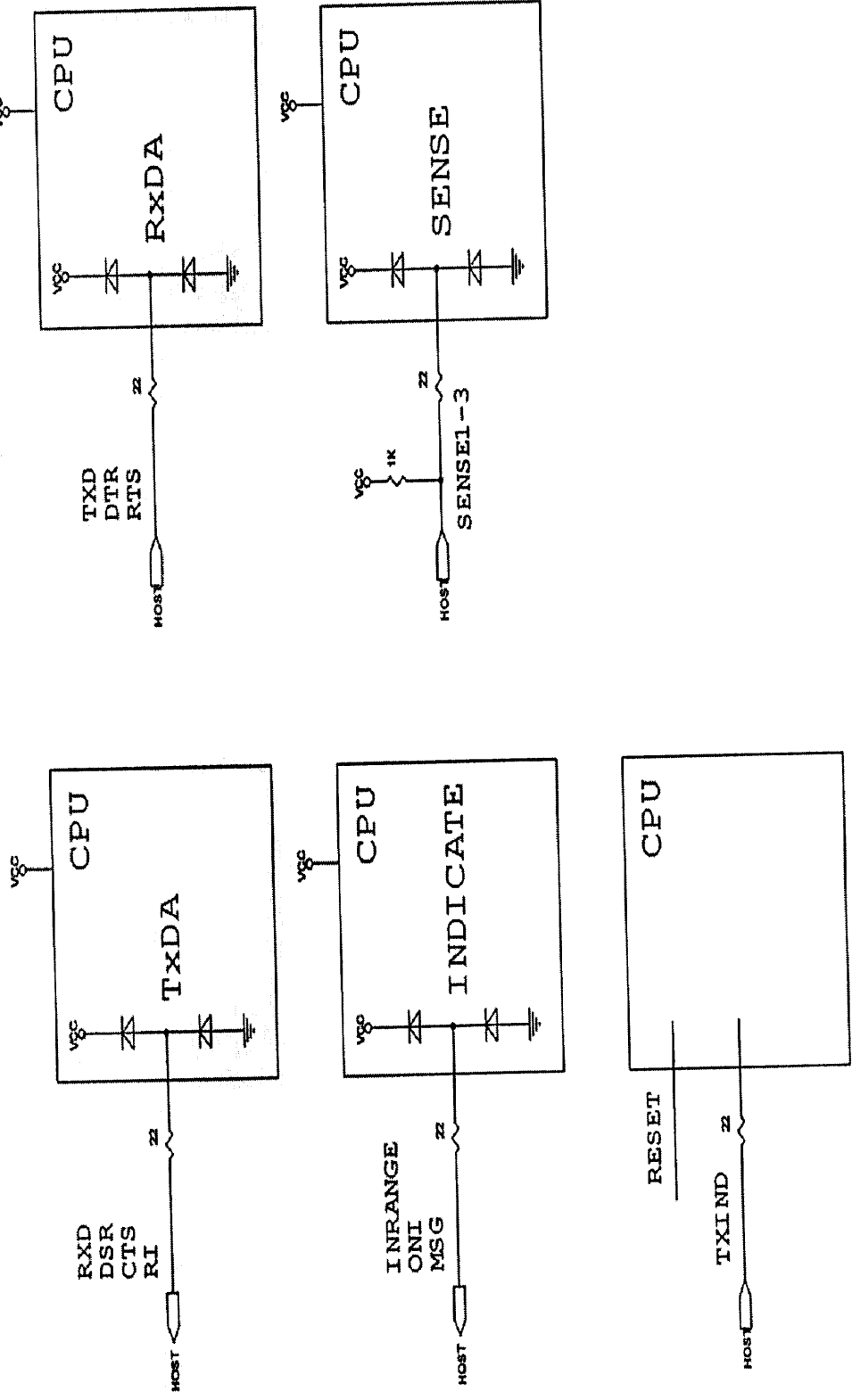

3. Power Supply

Example of Power Supply from out-source : input Voltage is $5V \pm 10\%$, current is about 2[A].

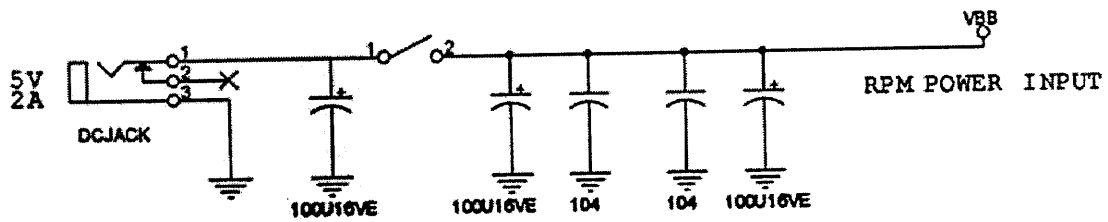

■ Design Considerations

To integrate a wireless modem, there are several issues that need to be addressed and considered. Internal connections and placement are critical to a successful implementation. A successful design requires attention to several support mechanisms as following:

- DC Power
- Serial interface and control
- Mechanical mounting
- Software
- Antenna
- RF control

1. Production Applications

The OEM wireless modem is well suited for mobile and fixed applications. The wireless modem enables user to send/receive data anytime anywhere, and can provide communications for a wide variety of products

1.1 Portable Terminal Use

Portable designs produce good environment for an integrated modem. The portable terminal is typically battery powered, subject to temperature extremes, and designed to be physically strong. When designing portable device, user needs to pay attention to the following issue:

- DC power noise levels on the host interface
- Minimum operating voltage levels
- Device internal ambient temperature
- Antenna gain and proximity to user
- Mechanical design for drop, vibration, dust, salt and liquid spill.

Note : Regarding this last point, CNI-903M modem is designed on the assumption that the host device will control these conditions

1.2 Fixed Mount Usage

Fixed-mount usage eliminates most of the mechanical constraints of handheld designs. The core requirement applies, but fixed usage does not present any special conditions to address.

■ Installation

Installing CNI-903M modem is very simple as follows:

- Place the modem to connector on product housing, and apply a little force to push it down to be connected.

Caution : Care not to bend or damage the connector pins.

- Use four #2-56 UNC 2A machine screws to tie up the modem as the figure shown below.
- Connect modem connection cable to a small hole provided at the rear of the modem.
- Connect the modem connection cable to Antenna

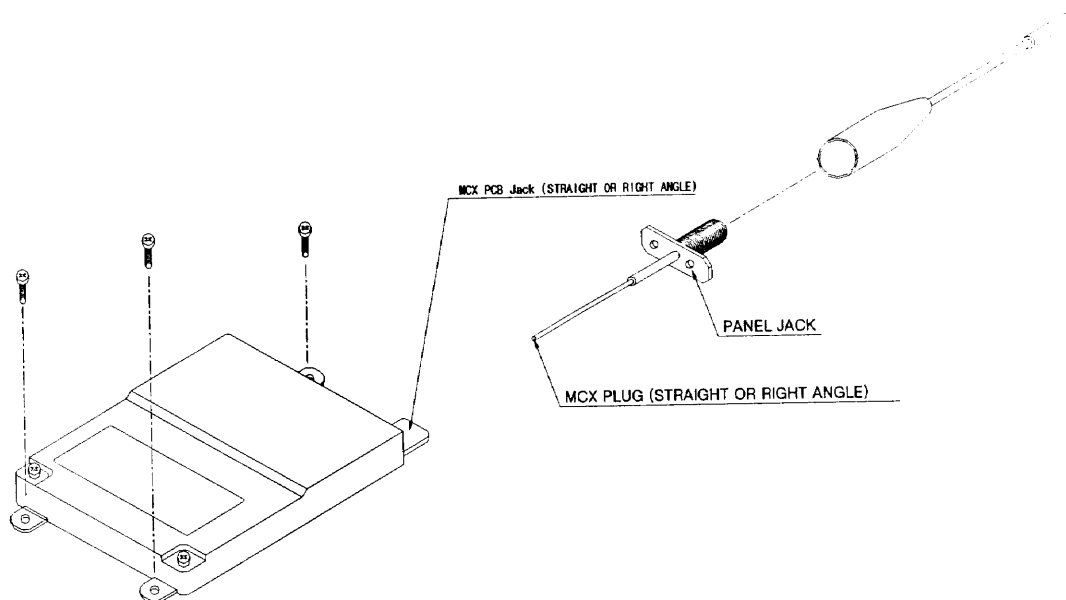

1. Mounting

Proper mounting of the modem requires a combination of securely fastening it within the product housing as well as adequately grounding the modem case to the housing.

1.1 Fastening

Mount the modem to the rigid OEM product housing by using four #2-56 UNC 2A machine screws as the figure shown below.

1.2 Grounding

For CNI-903M modem, the pin number 3 of connector on the modem is ground pin. So if user properly places the modem, ground is automatically done.

■ **Warning Label**

Following warning label shall be attached on the devices using CNI-903M modem.

While this device is in operation, a separation distance of at least 20 centimeters (7.87 inches) is maintained between radiating antenna and the body of the user or nearby persons in order to meet the FCC RF exposure guidelines.

■ Antenna Specification

Product Name : Whip Antenna of 900MHz Range

MODEL : HA-900-SSMA

Manufacturer : HanKook Antenna Company

① Application

This specification describes $\lambda/4$ WHIP ANTENNA used for frequency range of 900MHz for transmission DATA of wireless.

② Conditions of using Antenna

■ Handheld ■ Fixed ■ Mobile ■ Outdoor ■ Indoor □ Others

③ Shape of Antenna

Refer to attached drawing No.

④ Electrical features and Performance

Item	Features/Performance	Remark
Frequency range	896 ~ 941 MHz	
Nominal impedance	50 Ω	
V.S.W.R	1 : 2.0	
Radiation	Omni-direction	
Polarization	Vertical	
Gain	Unity	

⑤ Structural Specification

Item	Specification/Features	Remark
Radiator	$\varnothing 1.5$ Speedo wire	
Sleeve	Shrinkable Tube	F-Type $\varnothing 1.5$
Connector	SMA-Plug	Ni-plating
Total length	85 ± 3 mm	

⑥ Other features and performance**A. Temperature**

Antenna shall not be deformed or damaged and shall satisfy “Clause 4” in this specification after Placing Antenna at -30°C and 70°C for 96 hours.

B. Humidity

After placing Antenna at surrounding temp. 40°C with relative humidity of 90 ~ 95 for 96 hours, antenna shall not be deformed or damaged, and shall satisfy “Clause 4” in this specification

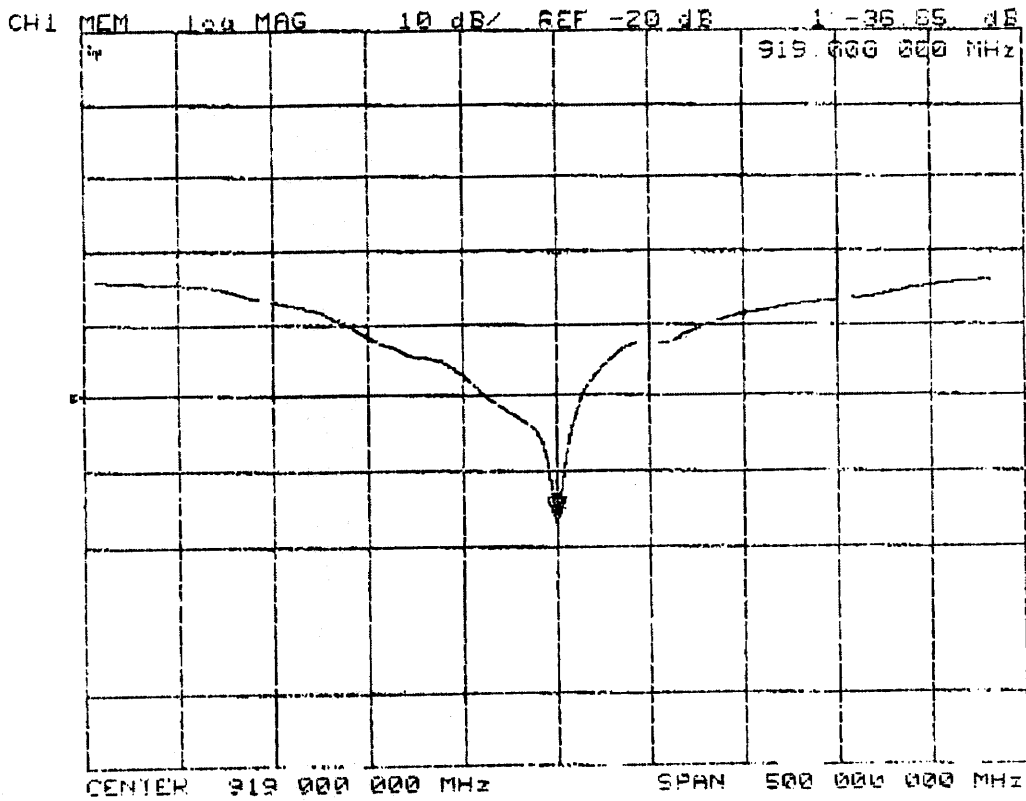

< Picture 1 >

Stimulus [MHz]	CH1 MEN [dB]	Stimulus [MHz]	CH1 MEN [dB]
894.000	-22.322	931.000	-21.178
896.000	-22.71	934.000	-19.697
899.000	-23.158	936.000	-18.528
901.000	-23.608	939.000	-17.647
904.000	-23.981	941.000	-16.942
906.000	-24.393	944.000	-16.216
909.000	-24.983	946.000	-15.56
911.000	-26.191	949.000	-14.903
914.000	-28.439	951.000	-14.273
916.000	-32.236	954.000	-13.759
919.000	-36.85	956.000	-13.303
921.000	-33.206	959.000	-12.973
924.000	-28.902	961.000	-12.718
928.000	-25.681	964.000	-12.636
929.000	-23.126	966.000	-12.401

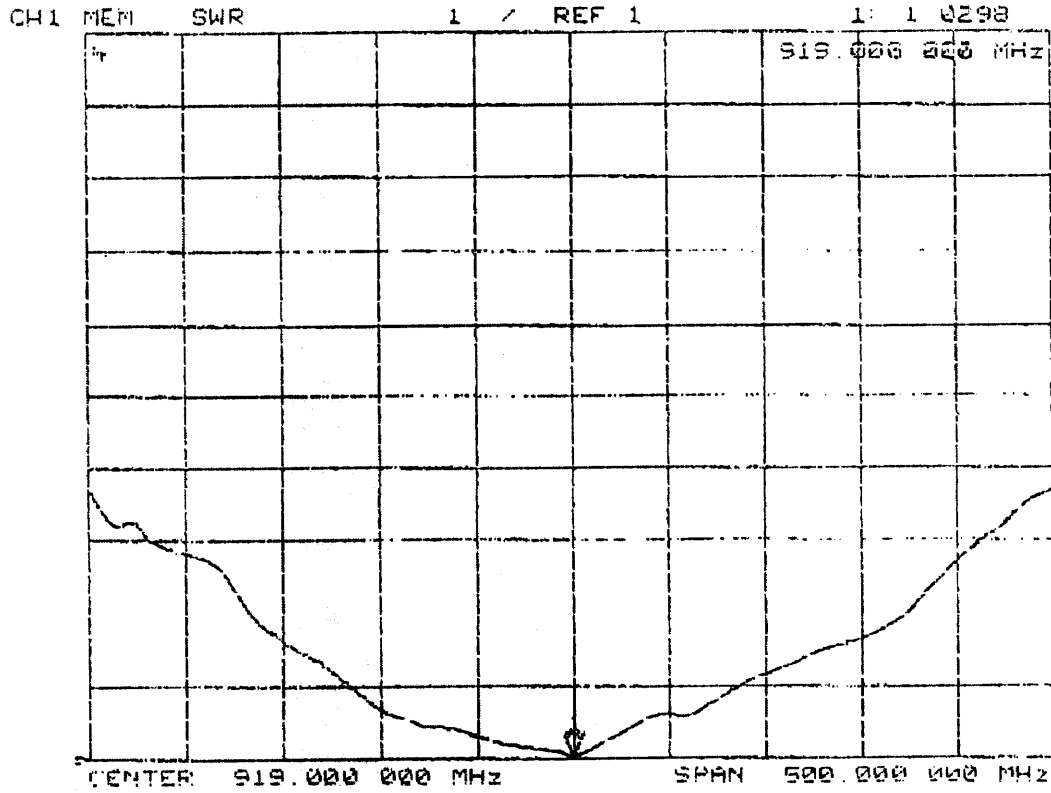

< Picture 2 >

Stimulus [MHz]	CH1 MEN [dB]	Stimulus [MHz]	CH1 MEN [dB]
894.000	1.1658	931.000	1.1919
896.000	1.1579	934.000	1.231
899.000	1.1494	936.000	1.2688
901.000	1.1413	939.000	1.3018
904.000	1.1349	941.000	1.3315
906.000	1.1283	944.000	1.3657
909.000	1.1134	946.000	1.4001
911.000	1.1331	949.000	1.4386
914.000	1.0787	951.000	1.4792
916.000	1.0501	954.000	1.5162
919.000	1.0298	956.000	1.5516
921.000	1.0447	959.000	1.5793
924.000	1.0744	961.000	1.6017
928.000	1.1099	964.000	1.6182
929.000	1.16	966.000	1.631

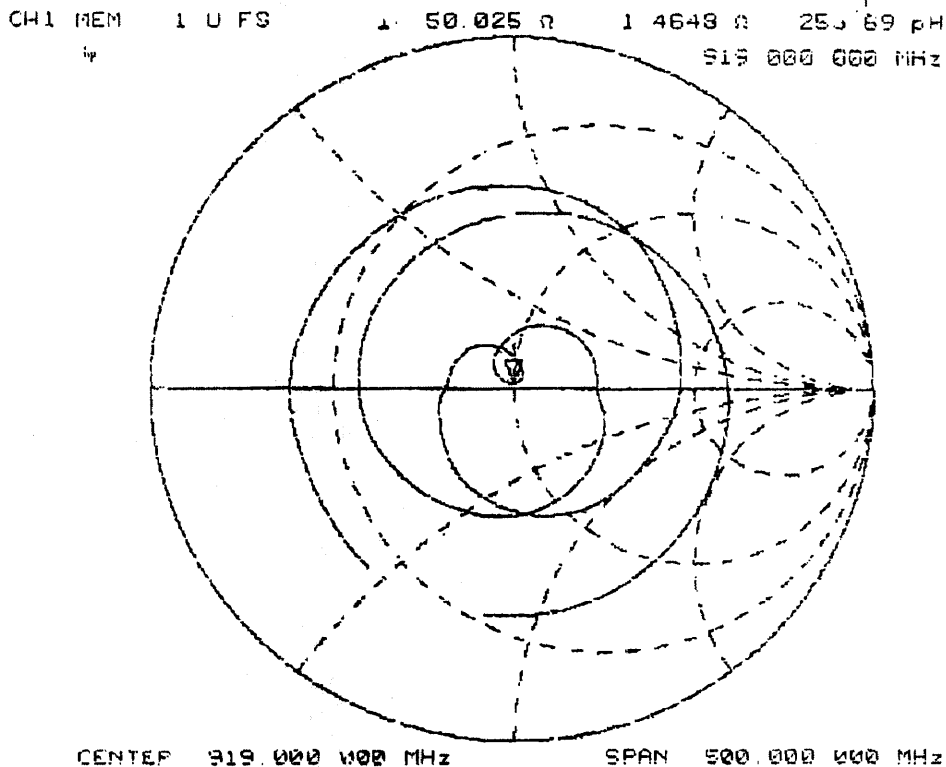

< Picture 3 >

Stimulus [MHz]	CH 1 MEN R [Ω]	CH 1 MEN X _L [Ω]	Stimulus [MHz]	CH 1 MEN R [Ω]	CH 1 MEN X _L [Ω]
894.000	50.727	7.6973	931.000	44.422	6.0938
896.000	51.014	7.3359	934.000	44.288	7.9629
899.000	51.324	6.9336	936.000	44.541	9.8516
901.000	51.551	6.5312	939.000	45.236	11.643
904.000	51.783	6.1953	941.000	46.184	13.26
906.000	52.045	5.8164	944.000	47.193	14.941
909.000	52.516	5.207	946.000	48.588	16.607
911.000	52.674	4.2658	949.000	50.299	18.336
914.000	52.416	3.0273	951.000	52.605	20.037
916.000	51.477	1.9902	954.000	55.584	21.381
919.000	50.026	1.4648	956.000	59.186	22.271
921.000	48.972	1.6152	959.000	63.238	22.281
924.000	47.242	2.1387	961.000	67.991	21.43
928.000	48.064	3.0977	964.000	71.57	19.496
929.000	46.029	4.4043	966.000	75.488	16.547

Antenna Dimension

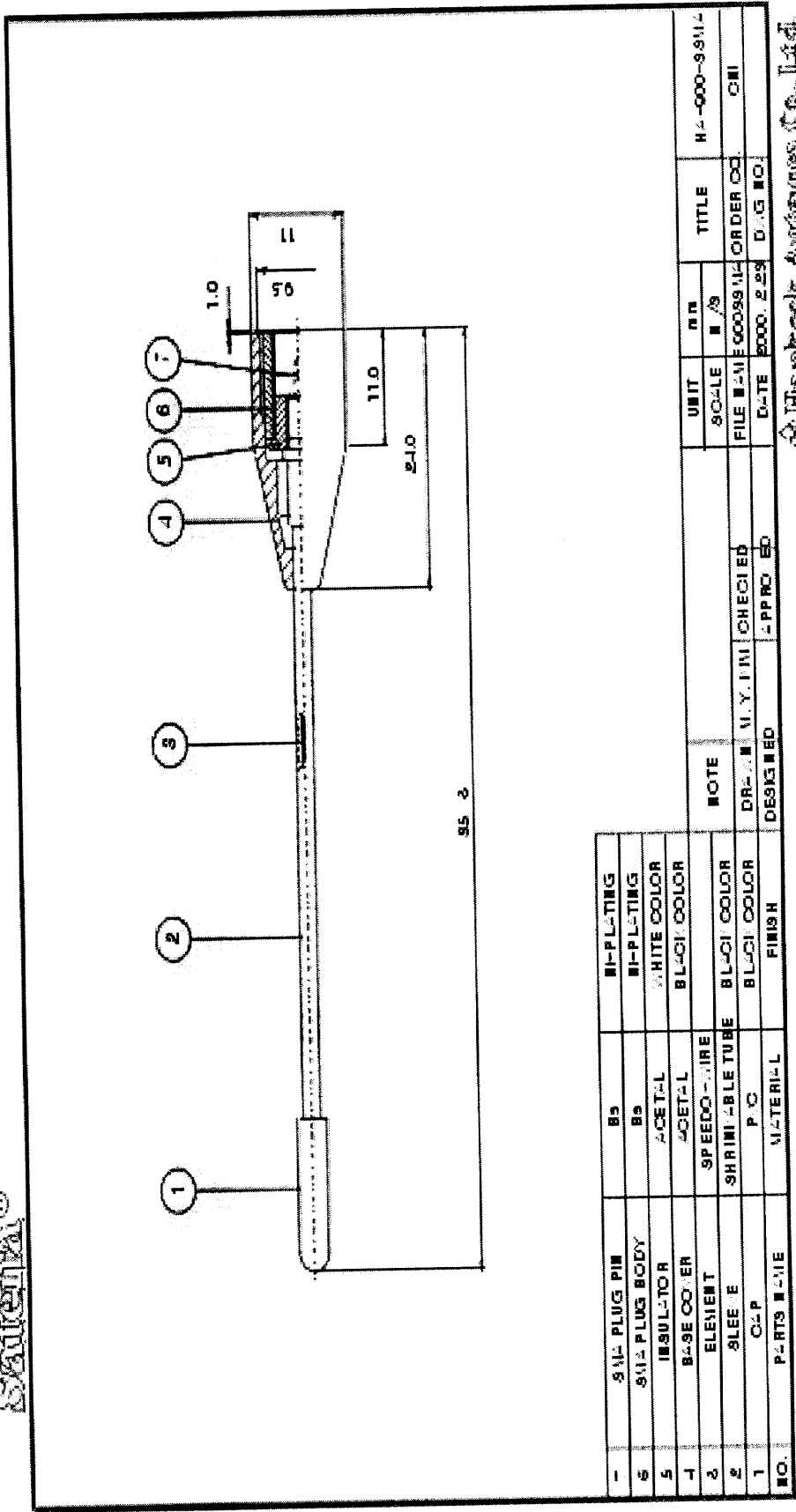

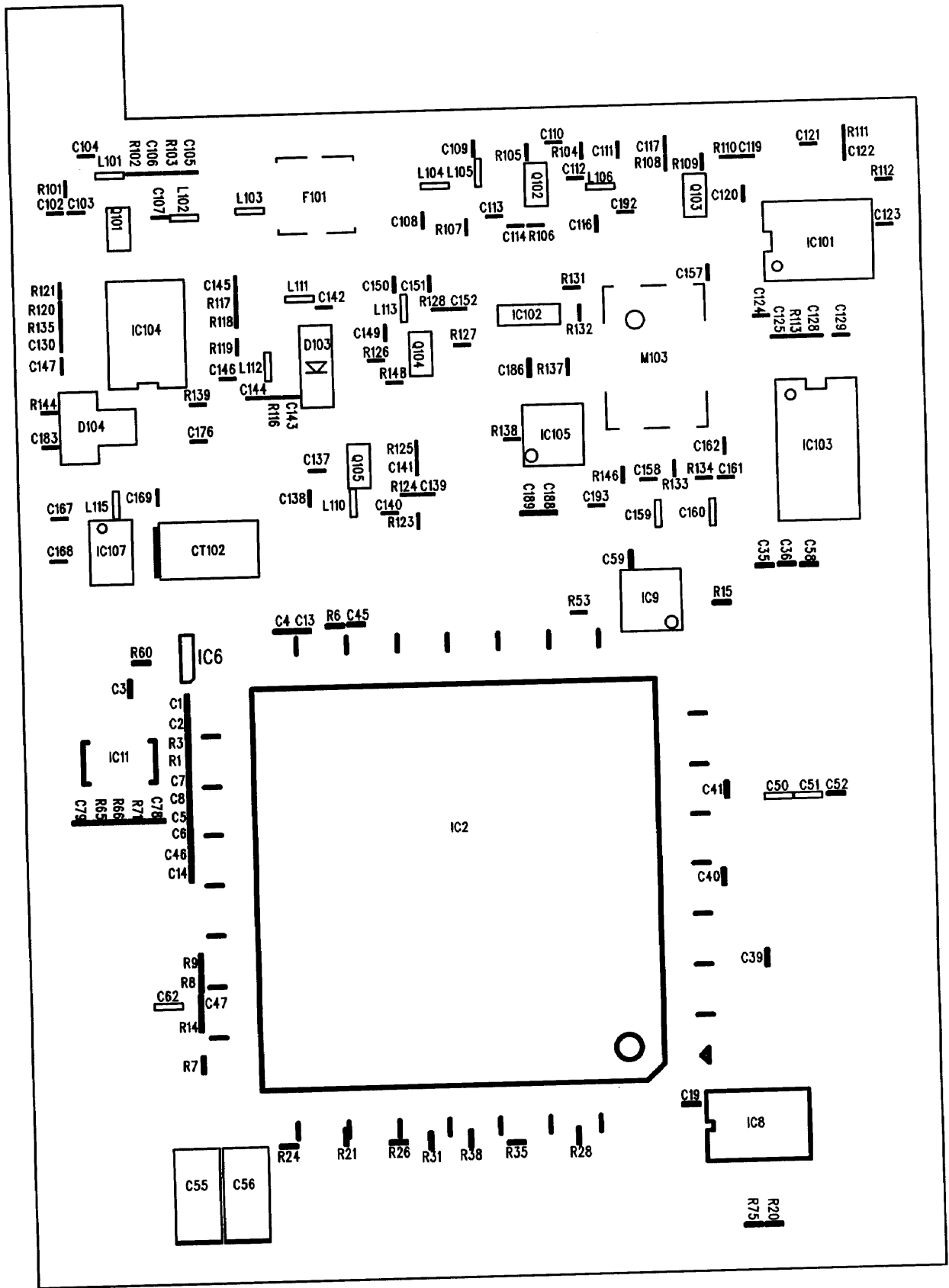

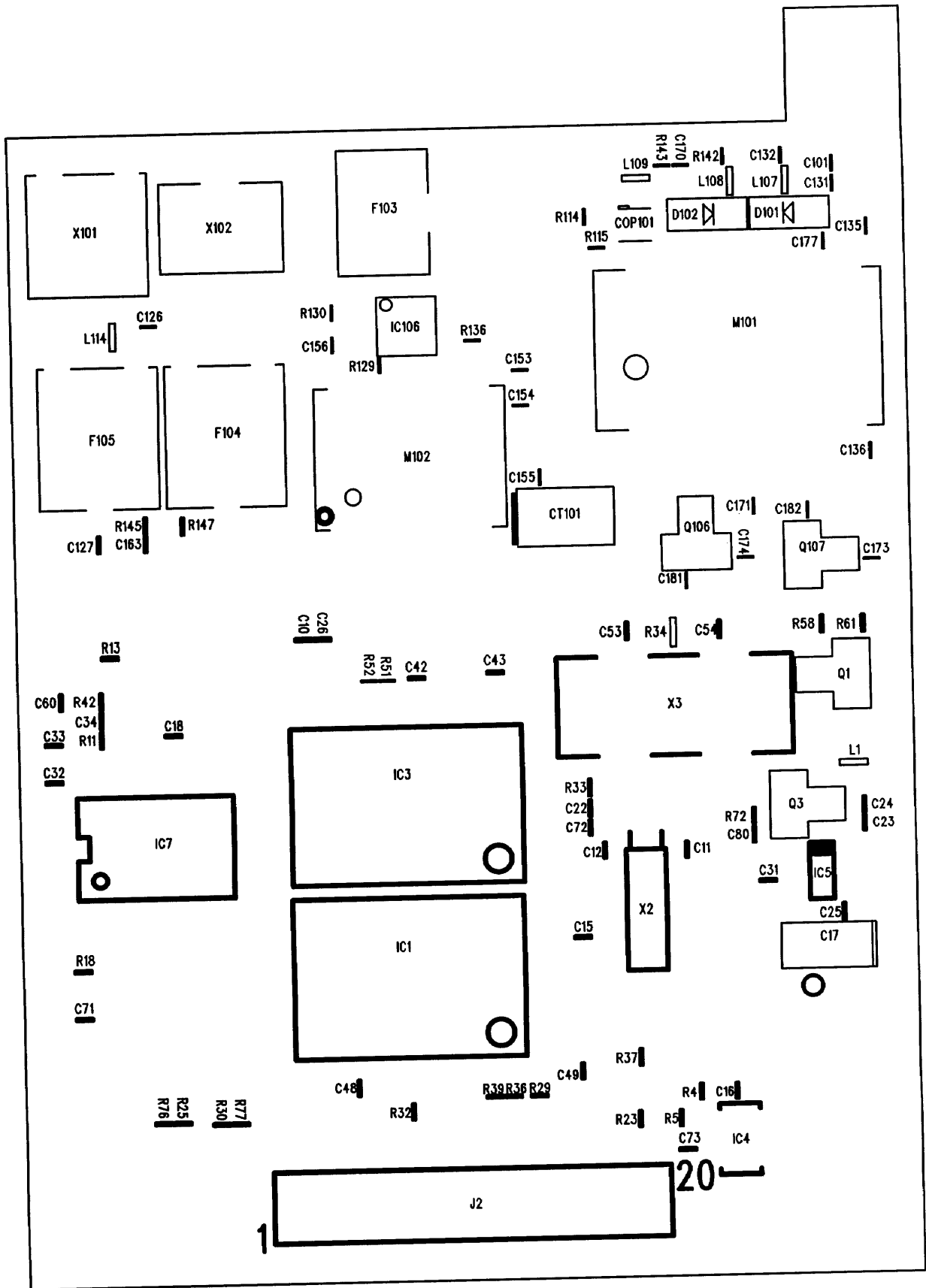

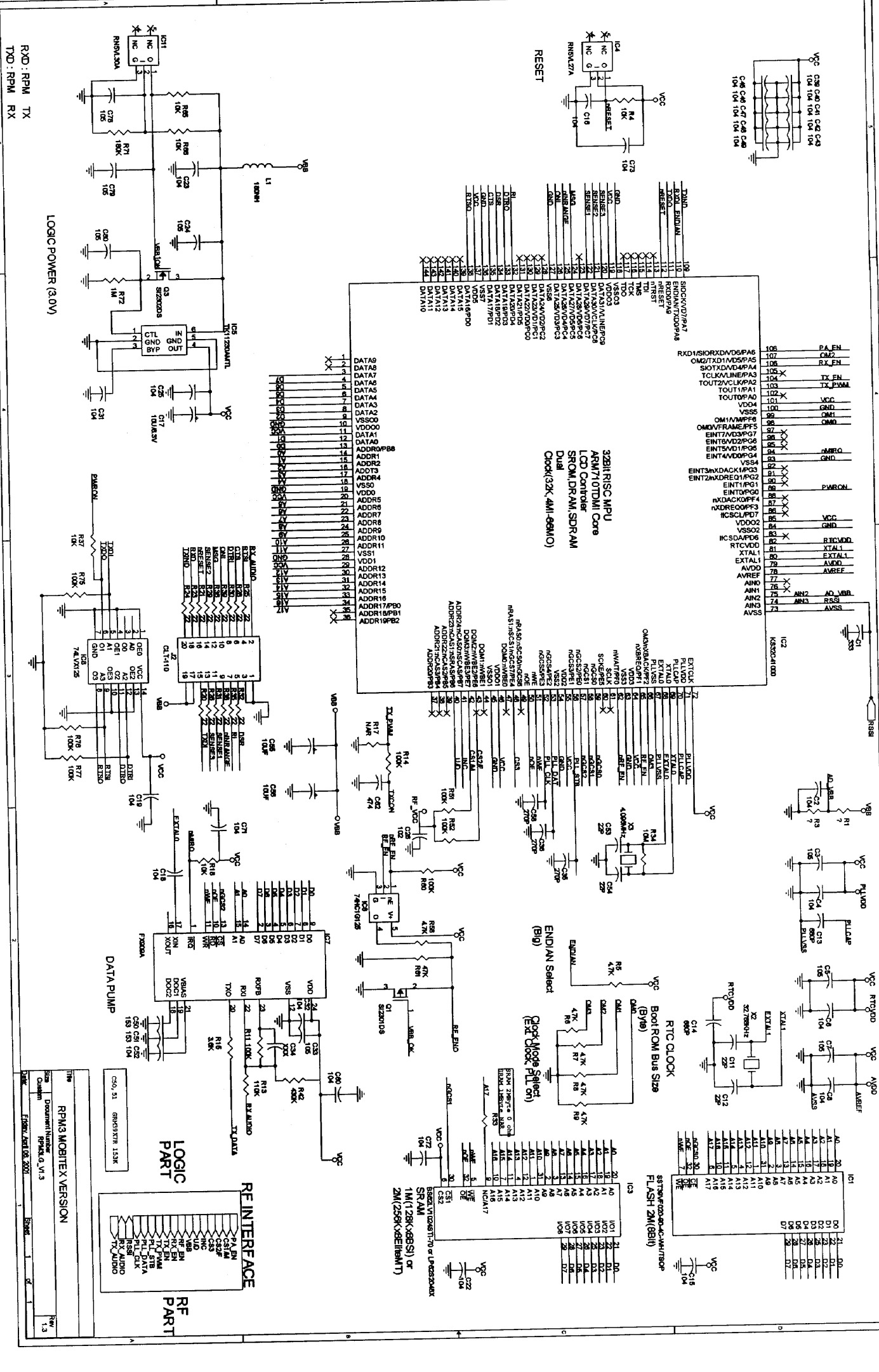

RP33M30B00
RP33M30B00 V1.3
RP33M30B00 V1.3
RP33M30B00 V1.3

RP33M30B00 V1.3
RP33M30B00 V1.3
RP33M30B00 V1.3

RP33M30B00 V1.3
RP33M30B00 V1.3
RP33M30B00 V1.3

RP33M30B00 V1.3
RP33M30B00 V1.3
RP33M30B00 V1.3

RP33M30B00 V1.3
RP33M30B00 V1.3
RP33M30B00 V1.3

RP33M30B00 V1.3
RP33M30B00 V1.3
RP33M30B00 V1.3

RP33M30B00 V1.3
RP33M30B00 V1.3
RP33M30B00 V1.3

RP33M30B00 V1.3
RP33M30B00 V1.3
RP33M30B00 V1.3

RP33M30B00 V1.3
RP33M30B00 V1.3
RP33M30B00 V1.3

RP33M30B00 V1.3
RP33M30B00 V1.3
RP33M30B00 V1.3

RP33M30B00 V1.3
RP33M30B00 V1.3
RP33M30B00 V1.3

RP33M30B00 V1.3
RP33M30B00 V1.3
RP33M30B00 V1.3

RP33M30B00 V1.3
RP33M30B00 V1.3
RP33M30B00 V1.3

RP33M30B00 V1.3
RP33M30B00 V1.3
RP33M30B00 V1.3

RP33M30B00 V1.3
RP33M30B00 V1.3
RP33M30B00 V1.3

RP33M30B00 V1.3
RP33M30B00 V1.3
RP33M30B00 V1.3

RP33M30B00 V1.3
RP33M30B00 V1.3
RP33M30B00 V1.3

RP33M30B00 V1.3
RP33M30B00 V1.3
RP33M30B00 V1.3

RP33M30B00 V1.3
RP33M30B00 V1.3
RP33M30B00 V1.3

RP33M30B00 V1.3
RP33M30B00 V1.3
RP33M30B00 V1.3

CNI-903M RF SCH.

RX freq : 935MHZ-941MHZ
 TX freq : 896MHZ-902MHZ

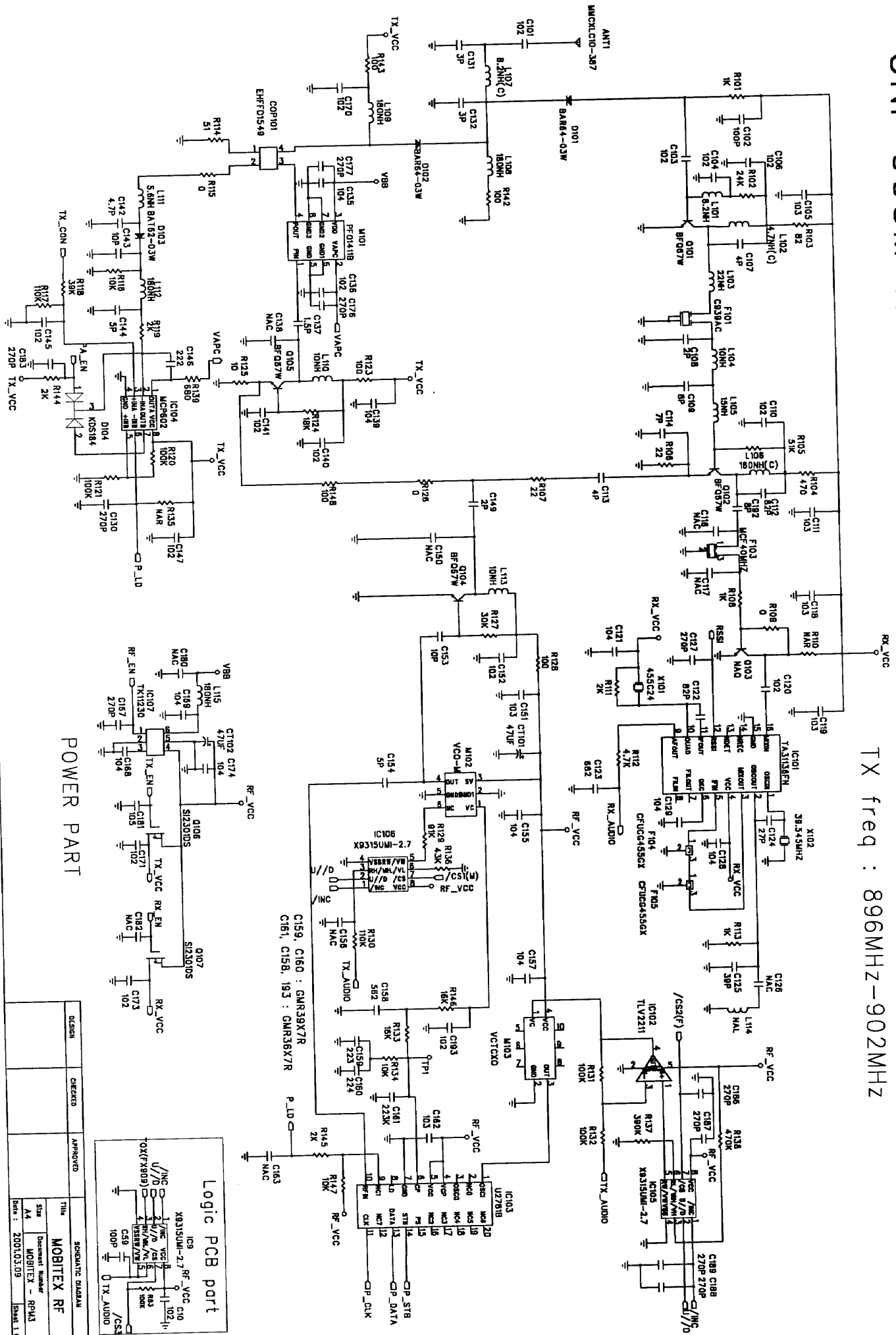

POWER PART

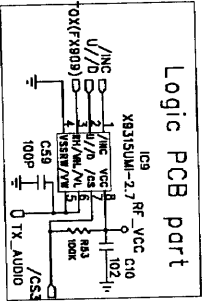

DESIGN	CHECKED	APPROVED	THIS	MOBITEK RF
Size	Document Number	MOBITEK - RPK43	REV	1.3
Date :	2001.03.09	Sheet 1 of 1		

REV.	EQD-NO	DATE

RF Block Diagram

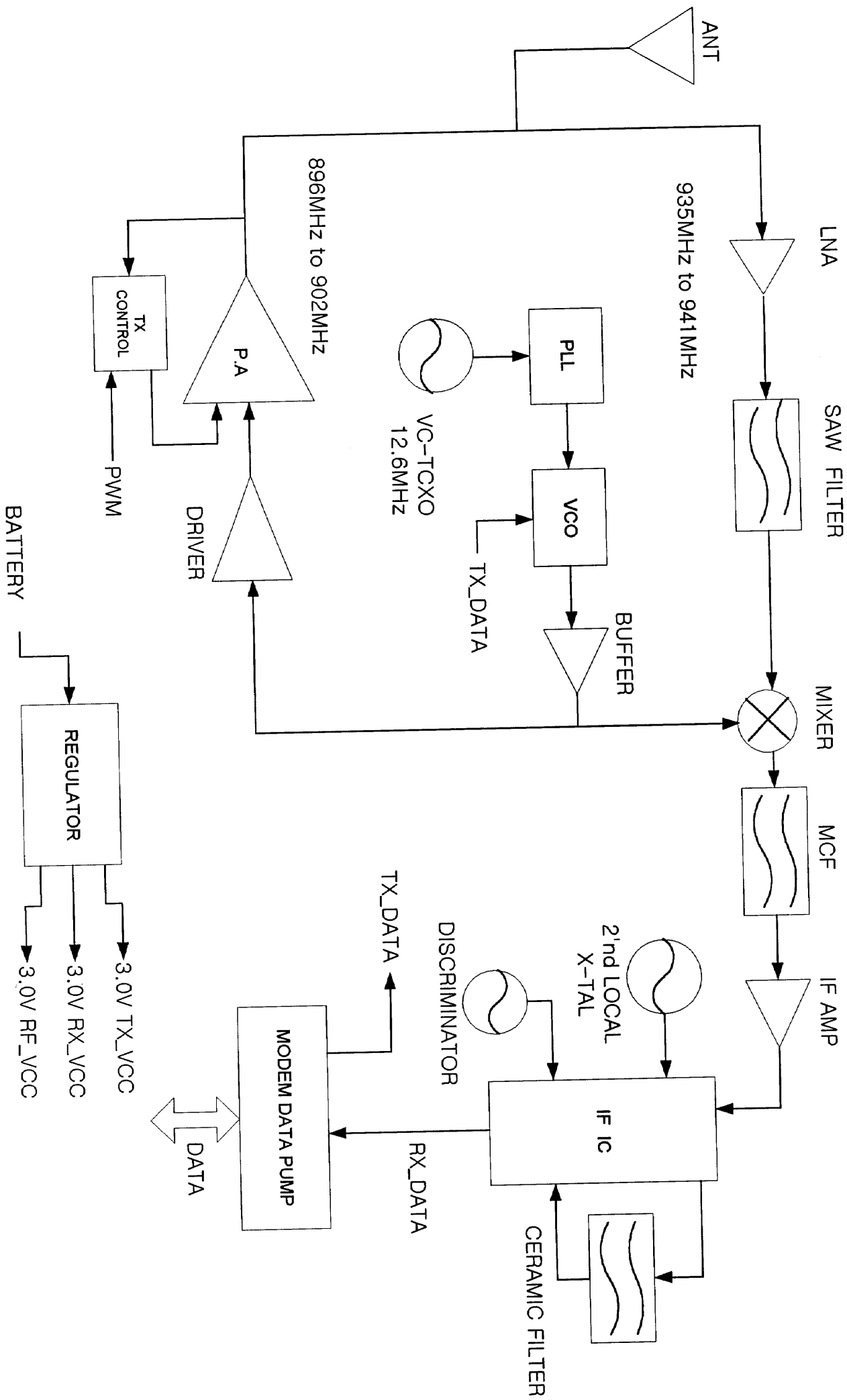

CNI 903M LOGIC BLOCK DIAGRAM

