



# Intertek Testing Services

*Evaluation of Compliance with FCC-Specified Guidelines for  
Human Exposure to Radio Frequency Electromagnetic Fields*

on the

**Radio Packet Modem Module  
Model: CNI-800D  
FCC ID: N79CNI-800D**

for

**Communication Network Interface Inc.**

Date of Test: November 23, 1999

Job # J99030365

Total No. of Pages Contained in this Report: 8 + data pages

All services undertaken are subject to the following general policy: Reports are submitted for exclusive use of the client to whom they are addressed. Their significance is subject to the adequacy and representative character of the samples and to the comprehensiveness of the tests, examinations or surveys made. No quotations from reports or use of Intertek Testing Services' name is permitted except as expressly authorized by Intertek Testing Services in writing.

FCC 2.1091 & ANSI 95.1-1992

**VERIFICATION OF COMPLIANCE**

**No. J99030365**

Verification is hereby issued to the named APPLICANT and is VALID ONLY for the equipment identified hereon for use under the rules and regulations listed below.

<b>Equipment Under Test:</b>	Radio Packet Modem Module
<b>Trade Name:</b>	CNI
<b>FCC ID:</b>	N79CNI-800D
<b>Model No.:</b>	CNI-800D
<b>Serial No.:</b>	Not Labeled
<b>Applicant:</b>	Communication Network Interface Inc.
<b>Contact:</b>	Mr. Won S. Lee
<b>Address:</b>	165-5, Dongkyo-Dong, Mapo-Ku Seoul 121-200, Korea
<b>Tel. number:</b>	82-2-330-5626
<b>Fax number:</b>	82-2-330-5733
<b>Applicable Regulation:</b>	FCC 2.1091 & ANSI C95.1:1992
<b>Equipment Class:</b>	Uncontrolled Environments
<b>Date of Test:</b>	November 23, 1999

*We attest to the accuracy of this report:*

  
Xi-Ming Yang  
Xi-Ming Yang  
Test Engineer

David Chernomordik  
David Chernomordik  
Engineering Manager

**Table of Contents**

1.0	<b>Introduction</b> .....	1
2.0	<b>Description of Equipment</b> .....	1
3.0	<b>Test Summary</b> .....	1
4.0	<b>System Test Configuration</b> .....	2
	4.1 Support Equipment .....	2
	4.2 Block Diagram of Test Setup .....	2
	4.3 Justification .....	3
	4.4 Software Exercise Program .....	3
	4.5 Mode of Operation During Test.....	3
	4.6 Modifications Required for Compliance .....	3
5.0	<b>Radiated Emissions</b> .....	4
	5.1 Radiated Emission Limits .....	4
	5.2 Site Description and List of Test Equipment. ....	5
	5.3 Test Procedure .....	5
	5.4 Field Strength Calculation.....	5
	5.5 Configuration Photographs.....	6
	5.6 Test Data.....	7
6.0	<b>Miscellaneous Information or Other Comments</b> .....	8

Communication Network Interface Inc., Radio Packet Modem Module Date of Test: November 23, 1999

## 1.0 Introduction

This report is designed to show compliance with the FCC Part 2.1091 Radio Frequency Radiation Exposure Evaluation for mobile and unlicensed devices. The test procedures and limits, as described in American National Standards Institute C95.1-1992, were employed. A description of the product and operating configuration, the various provisions of the rules, the methods for determining compliance, and a detailed summary of the results are included within this test report.

## 2.0 Description of Equipment

The CNI Model No.: CNI-800D is a radio packet modem module with frequency range from 806 - 821 MHz.

The radio packet modem module was used with the following antennas:

	Model Number	Vender	Type	Gain
#1	HA-850W-SSMA	Hnakook Antenna	WHIP	Unity (0dBi)
#2	HR850	ACE Technology	WHIP	Unity (0dBi)
#3	HA-900-SSMA	Hnakook Antenna	WHIP	Unity (0dBi)

## 3.0 Test Summary

The CNI-800D radio packet modem module was tested by Intertek Testing Services as documented herein, and the energy emitted by the EUT was found to be below the recommended levels of Maximum Permissible Exposure for Uncontrolled Environments in FCC 1.1310 (ANSI C95.1: 1992).

Therefore, in reference to the limits set forth in FCC 1.1310 use of the equipment is deemed to be safe with respect to human exposure to Radio Frequency Electromagnetic Fields, when used in a normal fashion.

**4.0 System Test Configuration**

**4.1 Support Equipment**

Item #	Description	Model No.	Serial No.	FCC ID
1	Sony Computer	PCG-F150	28986430	DOC B
2	Extech Power Supply	EP-3003	N/A	N/A
3	CNI Test Board	RPM I/F	N/A	N/A
4	Antenna	N/A	N/A	N/A

**4.2 Block Diagram of Test Setup**

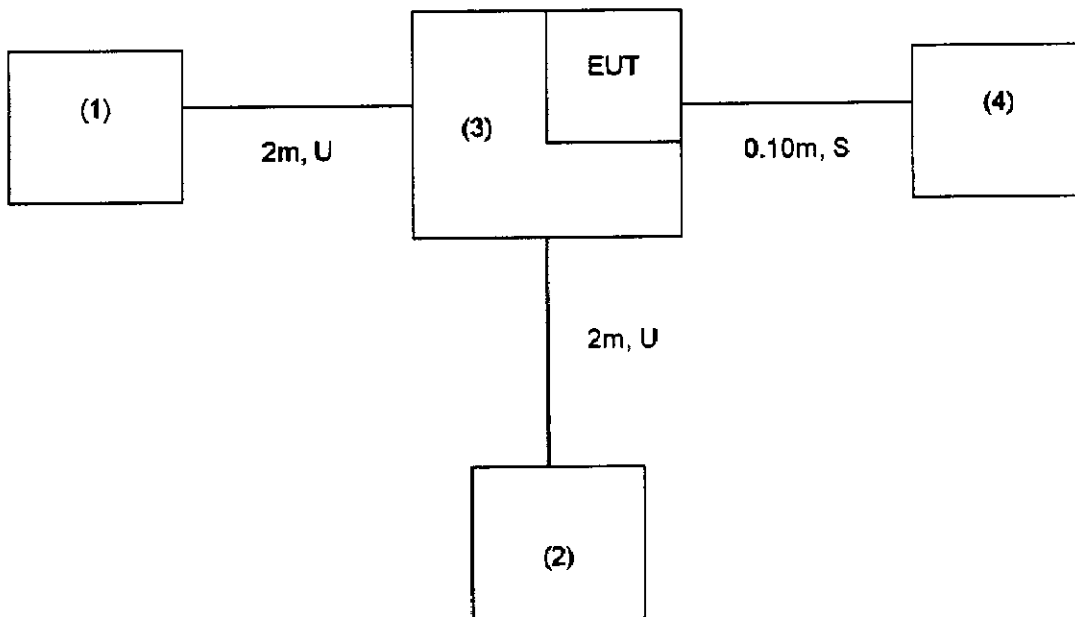

\* = EUT  
 \*\* = No ferrites on video cable  
 S = Shielded;  
 U = Unshielded  
 F = With Ferrite

#### 4.3 Justification

The system was configured for testing in a typical fashion (as a customer would normally use it).

#### 4.4 Software Exercise Program

The CNI software was used during the test.

#### 4.5 Mode of Operation During Test

Transmitting full power (0.47W).

#### 4.6 Modifications Required for Compliance

The following modifications were installed during compliance testing in order to bring the product into compliance (Please note that this list does not include changes made specifically by Communication Network Interface Inc. prior to compliance testing):

No modifications were installed by Intertek Testing Services.

Communication Network Interface Inc., Radio Packet Modem Module Date of Test: November 23, 1999

**5.0 Radiated Emissions****5.1 Radiated Emission Limits, FCC 1.1310**

The following exposure limits apply to equipment use in Uncontrolled Environments:

**Maximum Permissible Exposure for Uncontrolled Environments**

Frequency Range (MHZ)	Electric Field Strength (E) (V/m)	Magnetic Field Strength (H) (A/m)	Power Density (S) E-field, H-field (mW/cm <sup>2</sup> )	Averaging Time (Minutes)
0.3 - 1.34	614	1.63	*100	30
1.34 - 30	824/f	2.19/f	*180/f <sup>2</sup>	30
30 - 300	27.5	0.073	0.2	30
300 - 1500	-	-	f/1500	30
1500 - 100,000	-	-	1.0	30

\* = Plane-wave equivalent power density.

Dashes "-" are used to indicate that there is no limit under the guideline.

## 5.2 Site Description and List of Test Equipment.

All tests were performed on Open Area Test Site.

Measurement equipment used for radiated emission compliance testing utilized some of the equipment on the following list:

Manufacturer	Equipment	Model Number	Calibration Due
Holiday	Field Strength Meter	HI-3004EX	5/17/00

## 5.3 Test Procedure

The test was performed at 836 MHz. The antenna was placed on a 0.8m wooden table on open site. The antenna was connected to the EUT. EUT output power was measured at RF output connector. EUT has 0.47W ERP power output.

The sensor of the field strength meter was moved around the antenna to obtain the maximum reading of the field strength meter. The measurements were performed at the distance 0.1m to 1m from the antenna.

## 5.4 Field Strength Calculation

The field strength was measured directly from the meter. The power density (PD in  $W.m^2$ ) was calculated using the following formula:

$$Pd = E^2/120\pi$$

Where E is Field Strength in V/m



5.5 Configuration Photographs

**Radiated Emission**

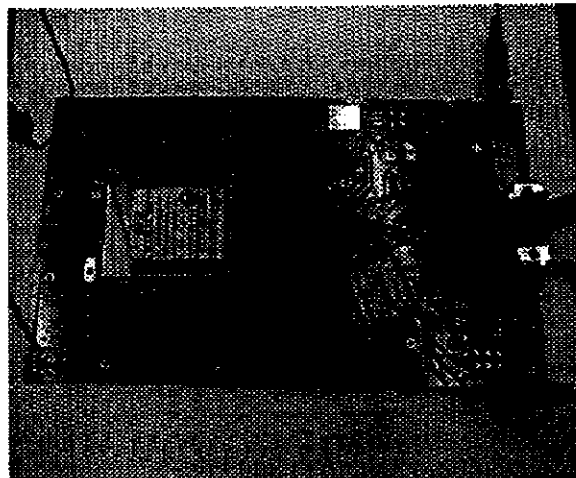
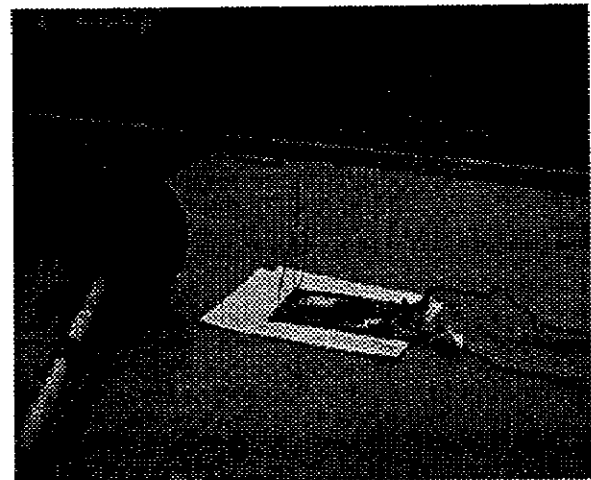
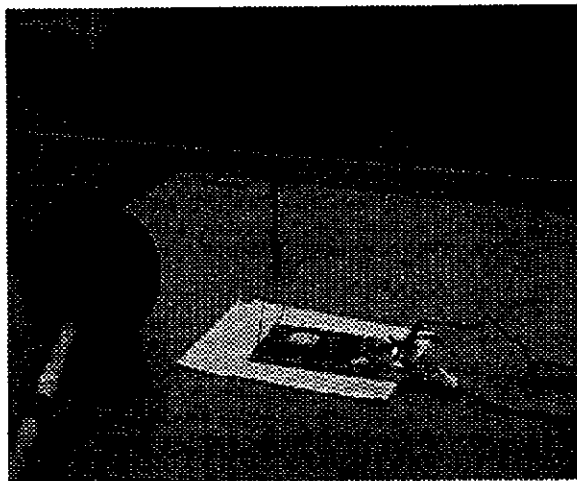
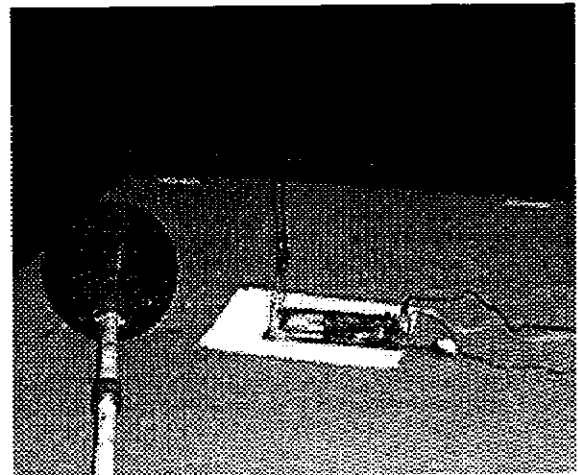
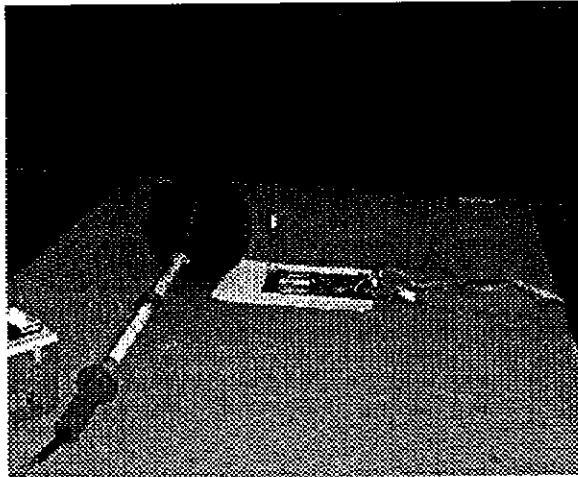

Communication Network Interface Inc., Radio Packet Modem Module Date of Test: November 23, 1999

## 5.6 Test Data

The results on the following page(s) were obtained when the device was tested in the condition described in section 4.

Module Used With Antenna #1			
Test Distance m	Maximum Field Strength Reading V/m	Calculated Power Density MW/cm <sup>2</sup>	FCC Limit for Time- Averaging Interval of 30 min. mW/cm <sup>2</sup>
0.1	28	0.21	0.54
0.2	10.5	0.026	0.54
0.3	7.5	0.015	0.54
0.5	4.5	0.0054	0.54
1.5	3.0	0.0023	0.54

Module Used With Antenna #2			
Test Distance m	Maximum Field Strength Reading V/m	Calculated Power Density MW/cm <sup>2</sup>	FCC Limit for Time- Averaging Interval of 30 min. mW/cm <sup>2</sup>
0.1	43	0.49	0.54
0.2	15	0.06	0.54
0.3	9.5	0.024	0.54
0.5	6.5	0.011	0.54
1.0	4.0	0.0042	0.54

Module Used With Antenna #3			
Test Distance m	Maximum Field Strength Reading V/m	Calculated Power Density MW/cm <sup>2</sup>	FCC Limit for Time- Averaging Interval of 30 min. mW/cm <sup>2</sup>
0.1	24	0.15	0.54
0.2	9.0	0.021	0.54
0.3	8.5	0.011	0.54
0.5	4.0	0.0042	0.54
1.0	2.8	0.0221	0.54

Judgment: Passed

**6.0 Miscellaneous Information or Other Comments**

None.