



SGS-CSTC Standards Technical Services (Shanghai) Co., Ltd.

588 West Jindu Road, Xinqiao, Songjiang, 201612 Shanghai, China
Telephone: +86 (0) 21 6191 5666
Fax: +86 (0) 21 6191 5678
ee.shanghai@sgs.com

Report No.: SHEM160800539503
Page: 1 of 43

1 Cover Page

RF TEST REPORT

Application No.:	SHEM1608005395CR
Applicant:	MINE SITE TECHNOLOGIES PTY LTD
FCC ID:	N73-PRX-CTRL
IC:	7449B-PRXCTRL
Equipment Under Test (EUT): NOTE: The following sample(s) was/were submitted and identified by the client as	
Product Name:	Proximity Controller
Model No.(EUT):	PRX-CTRL
Standards:	FCC PART 15 Subpart C RSS-247 Issue 2 RSS-Gen Issue 4
Date of Receipt:	2015-10-10
Date of Test:	2017-12-29 to 2018-03-10
Date of Issue:	2018-03-15
Test Result:	Pass*

*In the configuration tested, the EUT detailed in this report complied with the standards specified above.



Parlam Zhan
E&E Section Manager
SGS-CSTC (Shanghai) Co., Ltd.

The manufacturer should ensure that all products in series production are in conformity with the product sample detailed in this report. If the product in this report is used in any configuration other than that detailed in the report, the manufacturer must ensure the new system complies with all relevant standards.

The report must not be used by the client to claim product certification, approval, or endorsement by NVLAP, NIST, or any agency of the federal government. All test results in this report can be traceable to National or International Standards.

This document is issued by the Company subject to its General Conditions of Service printed overleaf, available on request or accessible at www.sgs.com/terms_and_conditions.htm and, for electronic format documents, subject to Terms and Conditions for Electronic Documents at www.sgs.com/terms_e-document.htm. Attention is drawn to the limitation of liability, indemnification and jurisdiction issues defined therein. Any holder of this document is advised that information contained hereon reflects the Company's findings at the time of its intervention only and within the limits of Client's instructions, if any. The Company's sole responsibility is to its Client and this document does not exonerate parties to a transaction from exercising all their rights and obligations under the transaction documents. This document cannot be reproduced except in full, without prior written approval of the Company. Any unauthorized alteration, forgery or falsification of the content or appearance of this document is unlawful and offenders may be prosecuted to the fullest extent of the law. Unless otherwise stated the results shown in this test report refer only to the sample(s) tested and such sample(s) are retained for 90 days only.

2 Version

Revision Record				
Version	Chapter	Date	Modifier	Remark
00	/	2018-03-15	/	Original

Authorized for issue by:			
Engineer		Vincent Zhu <hr/> Print Name	 <hr/>
Reviewer		Parlam Zhan <hr/> Print Name	 <hr/>

3 Test Summary

Test Item	FCC Requirement	IC Requirement	Test method	Result
Antenna Requirement	FCC Part 15, Subpart C Section 15.203/15.247 (c)	RSS-Gen Section 8.1.3	---	PASS
AC Power Line Conducted Emission	FCC Part 15, Subpart C Section 15.207	RSS-Gen Clause 8.8	ANSI C63.10 (2013) Section 6.2	N/A
Minimum 6dB Bandwidth	FCC Part 15, Subpart C Section 15.247 (a)(2)	RSS-247 Clause 5.2(1)	ANSI C63.10 (2013) Section 11.8.1	PASS
Conducted Peak Output Power	FCC Part 15, Subpart C Section 15.247 (b)(3)	RSS-247 Clause 5.4(4)	ANSI C63.10 (2013) Section 11.9.1.2	PASS
Power Spectrum Density	FCC Part 15, Subpart C Section 15.247 (e)	RSS-247 Clause 5.2(2)	ANSI C63.10 (2013) Section 11.10.2	PASS
RF Conducted Spurious Emissions and Band-edge	FCC Part 15, Subpart C Section 15.247(d)	RSS-247 Clause 5.5	ANSI C63.10 (2013) Section 11.11&11.13.3.2	PASS
Radiated Spurious Emissions and Band-edge	FCC Part 15, Subpart C Section 15.209&15.205	RSS-247 Clause 5.5	ANSI C63.10 (2013) Section 6.4&6.5&6.6&6.10	PASS
99% Occupied bandwidth	---	RSS-Gen Clause 6.6	RSS-Gen Issue 4 section 6.6	PASS

N/A: This EUT is powered by battery only; therefore the test on mains terminals is not applicable.



4 Contents

	Page
1 COVER PAGE	1
2 VERSION	2
3 TEST SUMMARY	3
4 CONTENTS	4
5 GENERAL INFORMATION	5
5.1 CLIENT INFORMATION.....	5
5.2 GENERAL DESCRIPTION OF E.U.T.....	5
5.3 TECHNICAL SPECIFICATIONS.....	5
5.4 DESCRIPTION OF SUPPORT UNITS.....	5
5.5 DETAILS OF TEST MODE	5
5.6 TEST LOCATION	5
5.7 TEST FACILITY	6
5.8 MEASUREMENT UNCERTAINTY	7
6 EQUIPMENTS LIST	8
7 ANTENNA REQUIREMENT	9
7.1 E.U.T. TEST CONDITIONS	9
7.2 ANTENNA REQUIREMENT.....	10
7.3 CONDUCTED EMISSIONS ON MAINS TERMINALS	11
7.4 6dB OCCUPIED BANDWIDTH.....	13
7.5 CONDUCTED PEAK OUTPUT POWER	16
7.6 PEAK POWER SPECTRAL DENSITY.....	19
7.7 CONDUCTED SPURIOUS EMISSIONS AND BAND EDGE.....	22
7.7.1 <i>Conducted Spurious Emissions</i>	23
7.7.2 <i>Conducted Band-edge</i>	26
7.8 RADIATED SPURIOUS EMISSIONS AND BAND-EDGE.....	27
7.8.1 <i>Radiated Spurious Emissions</i>	30
7.8.2 <i>Radiated Band-edge</i>	34
7.1 99% OCCUPIED BANDWIDTH	40
8 TEST SETUP PHOTOGRAPHS	43
9 EUT CONSTRUCTIONAL DETAILS	43

5 General Information

5.1 Client Information

Applicant:	MINE SITE TECHNOLOGIES PTY LTD
Address of Applicant:	Level 5, 113 Wicks Rd., North Ryde NSW 2113

5.2 General Description of E.U.T.

Product Description:	Mobile Product with 2.4GHz band Zigbee function
Power Supply:	DC 24V by battery

5.3 Technical Specifications

Operation Frequency:	2405MHz-2470MHz
Modulation Type:	DSSS
Number of Channel:	14
Data Rate:	250kbps
Antenna Type	Whip antenna
Antenna Gain	3 dBi

5.4 Description of Support Units

The EUT has been tested with associated equipment below.

Description	Manufacturer	Model No.	Supplied by
Proximity Detection System Controller	MINE SITE TECHNOLOGIES PTY LTD	Proximity Detection System Controller	Client
Proximity Detection System Transmitter	MINE SITE TECHNOLOGIES PTY LTD	Proximity Detection System Transmitter	Client

5.5 Details of Test Mode

Test Mode	Description of Test Mode
Engineering Mode	Using test software to control EUT working in continuous transmitting and, and select channel and modulation type

5.6 Test Location

All tests were performed at:

SGS-CSTC Standards Technical Services (Shanghai) Co., Ltd.
588 West Jindu Road, Xinqiao, Songjiang, 201612 Shanghai, China
Tel: +86 21 6191 5666
Fax: +86 21 6191 5678

5.7 Test Facility

The test facility is recognized, certified, or accredited by the following organizations:

- **CNAS (No. CNAS L0599)**

CNAS has accredited SGS-CSTC Standards Technical Services (Shanghai) Co., Ltd. to ISO/IEC 17025:2005 General Requirements for the Competence of Testing and Calibration Laboratories (CNAS-CL01 Accreditation Criteria for the Competence of Testing and Calibration Laboratories) for the competence in the field of testing.

- **NVLAP (Certificate No. 201034-0)**

SGS-CSTC Standards Technical Services (Shanghai) Co., Ltd. is accredited by the National Voluntary Laboratory Accreditation Program (NVLAP). Certificate No. 201034-0.

- **FCC –Designation Number: CN5033**

SGS-CSTC Standards Technical Services (Shanghai) Co., Ltd. has been recognized as an accredited testing laboratory.

Designation Number: CN5033. Test Firm Registration Number: 479755.

- **Industry Canada (IC) – IC Assigned Code: 8617A**

The 3m Semi-anechoic chamber of SGS-CSTC Standards Technical Services (Shanghai) Co., Ltd. has been registered by Certification and Engineering Bureau of Industry Canada for radio equipment testing with Registration No.: 8617A-1.

- **VCCI (Member No.: 3061)**

The 3m Semi-anechoic chamber and Shielded Room of SGS-CSTC Standards Technical Services (Shanghai) Co., Ltd. has been registered in accordance with the Regulations for Voluntary Control Measures with Registration No.: R-3868, C-4336, T-12221, G-10830 respectively.

5.8 Measurement Uncertainty

No.	Parameter	Measurement Uncertainty
1	Radio Frequency	$< \pm 1 \times 10^{-5}$
2	Total RF power, conducted	$< \pm 1.5$ dB
3	RF power density, conducted	$< \pm 3$ dB
4	Spurious emissions, conducted	$< \pm 3$ dB
5	All emissions, radiated	$< \pm 6$ dB (Below 1GHz) $< \pm 6$ dB (Above 1GHz)
6	Temperature	$< \pm 1^{\circ}\text{C}$
7	Humidity	$< \pm 5$ %
8	DC and low frequency voltages	$< \pm 3$ %

6 Equipments List

Equipment	Manufacturer	Model No	Inventory No	Cal Date	Cal Due Date
Conducted Emission at AC Power Line					
EMI test receiver	R&S	ESR7	SHEM162-1	2017-12-20	2018-12-19
LISN	Schwarzbeck	NSLK8127	SHEM061-1	2017-12-20	2018-12-19
LISN	EMCO	3816/2	SHEM019-1	2017-12-20	2018-12-19
Pulse limiter	R&S	ESH3-Z2	SHEM029-1	2017-12-20	2018-12-19
CE test Cable	/	CE01	/	2017-12-26	2018-12-25
Conducted Test					
Spectrum Analyzer	R&S	FSP-30	SHEM002-1	2017-12-20	2018-12-19
Spectrum Analyzer	Agilent	N9020A	SHEM181-1	2017-09-26	2018-09-25
Power meter	R&S	NRP	SHEM057-1	2017-12-26	2018-12-25
Power Sensor	R&S	NRP-Z22	SHEM136-1	2017-07-22	2018-07-21
Power Sensor	R&S	NRP-Z91	SHEM057-2	2017-12-26	2018-12-25
Signal Generator	R&S	SMR40	SHEM058-1	2017-07-03	2018-07-02
Signal Generator	Agilent	N5182A	SHEM182-1	2017-09-26	2018-09-25
Communication Tester	R&S	CMW270	SHEM183-1	2017-10-22	2018-10-21
Switcher	Tonscend	JS0806	SHEM184-1	2017-09-26	2018-09-25
Splitter	Anritsu	MA1612A	SHEM185-1	/	/
Coupler	e-meca	803-S-1	SHEM186-1	/	/
High-low Temp Cabinet	Suzhou Zhihe	TL-40	SHEM087-1	2017-09-26	2018-09-25
AC Power Stabilizer	WOCEN	6100	SHEM045-1	2017-12-26	2018-12-25
DC Power Supply	QJE	QJ30003SII	SHEM046-1	2017-12-26	2018-12-25
Conducted test Cable	/	RF01, RF 02	/	2017-12-26	2018-12-25
Radiated Test					
EMI test receiver	R&S	ESU40	SHEM051-1	2017-12-20	2018-12-19
Spectrum Analyzer	R&S	FSP-30	SHEM002-1	2017-12-20	2018-12-19
Loop Antenna (9kHz-30MHz)	Schwarzbeck	FMZB1519	SHEM135-1	2017-04-10	2020-04-09
Antenna (25MHz-2GHz)	Schwarzbeck	VULB9168	SHEM048-1	2017-02-28	2020-02-27
Antenna (25MHz-3GHz)	Schwarzbeck	HL562	SHEM010-1	2017-02-28	2020-02-27
Horn Antenna (1-8GHz)	Schwarzbeck	HF906	SHEM009-1	2017-10-24	2020-10-23
Horn Antenna (1-18GHz)	Schwarzbeck	BBHA9120D	SHEM050-1	2017-01-14	2020-01-13
Horn Antenna (14-40GHz)	Schwarzbeck	BBHA 9170	SHEM049-1	2017-12-03	2020-12-02
Pre-amplifier (9KHz-2GHz)	CLAVIIO	BDLNA-0001-412010	SHEM164-1	2017-08-22	2018-08-21
Pre-amplifier (1-18GHz)	CLAVIIO	BDLNA-0118-352810	SHEM050-2	2017-08-22	2018-08-21
High-amplifier (14-40GHz)	Schwarzbeck	10001	SHEM049-2	2017-12-20	2018-12-19
Band filter	LORCH	9BRX-875/X150-SR	SHEM156-1	/	/
Band filter	LORCH	13BRX-1950/X500-SR	SHEM083-2	/	/
Band filter	LORCH	5BRX-2400/X200-SR	SHEM155-1	/	/
Band filter	LORCH	5BRX-5500/X1000-SR	SHEM157-2	/	/
High pass Filter	Wainwright	WHK3.0/18G-100SS	SHEM157-1	/	/
High pass Filter	Wainwright	WHKS1700-3SS	SHEM157-3	/	/
Semi/Fully Anechoic	ST	11*6*6M	SHEM078-2	2017-07-22	2020-07-21
RE test Cable	/	RE01, RE02, RE06	/	2017-12-26	2018-12-25

7 Antenna Requirement

7.1 E.U.T. test conditions

Requirements: 15.31(e) For intentional radiators, measurements of the variation of the input power or the radiated signal level of the fundamental frequency component of the emission, as appropriate, shall be performed with the supply voltage varied between 85% and 115% of the nominal rated supply voltage. For battery operated equipment, the equipment tests shall be performed using a new battery.

Operating Environment:	Temperature:	20.0 -25.0 °C
	Humidity:	35-75 % RH
	Atmospheric Pressure:	99.2 -102 kPa

Test frequencies: According to the 15.31(m) Measurements on intentional radiators or receivers, other than TV broadcast receivers, shall be performed and, if required, reported for each band in which the device can be operated with the device operating at the number of frequencies in each band specified in the following table:

Frequency range over which device operates	Number of frequencies	Location in the range of operation
1 MHz or less	1	Middle
1 to 10 MHz	2	1 near top and 1 near bottom
More than 10 MHz	3	1 near top, 1 near middle and 1 near bottom

Pursuant to Part 15.31(c) For swept frequency equipment, measurements shall be made with the frequency sweep stopped at those frequencies chosen for the measurements to be reported.

Test frequency is the lowest channel (2405MHz), middle channel (2440MHz) and highest channel (2470MHz)

7.2 Antenna Requirement

Standard requirement:

15.203 requirement:

An intentional radiator shall be designed to ensure that no antenna other than that furnished by the responsible party shall be used with the device. The use of a permanently attached antenna or of an antenna that uses a unique coupling to the intentional radiator, the manufacturer may design the unit so that a broken antenna can be replaced by the user, but the use of a standard antenna jack or electrical connector is prohibited.

15.247(b) (4) requirement:

The conducted output power limit specified in paragraph (b) of this section is based on the use of antennas with directional gains that do not exceed 6 dBi. Except as shown in paragraph (c) of this section, if transmitting antennas of directional gain greater than 6 dBi are used, the conducted output power from the intentional radiator shall be reduced below the stated values in paragraphs (b)(1), (b)(2), and (b)(3) of this section, as appropriate, by the amount in dB that the directional gain of the antenna exceeds 6 dBi.

EUT Antenna:

The antenna is integral antenna and no consideration of replacement. The gain of the antenna is less than 3 dBi.



7.3 Conducted Emissions on Mains Terminals

Frequency Range: 150 KHz to 30 MHz

Limit:

Frequency range MHz	Class B Limits: dB (µV)	
	Quasi-peak	Average
0.15 to 0.50	66 to 56	56 to 46
0.50 to 5	56	46
5 to 30	60	50

Note1: The limit decreases linearly with the logarithm of the frequency in the range 0.15 MHz to 0.50MHz.

Note2: The lower limit is applicable at the transition frequency.

Test Setup:

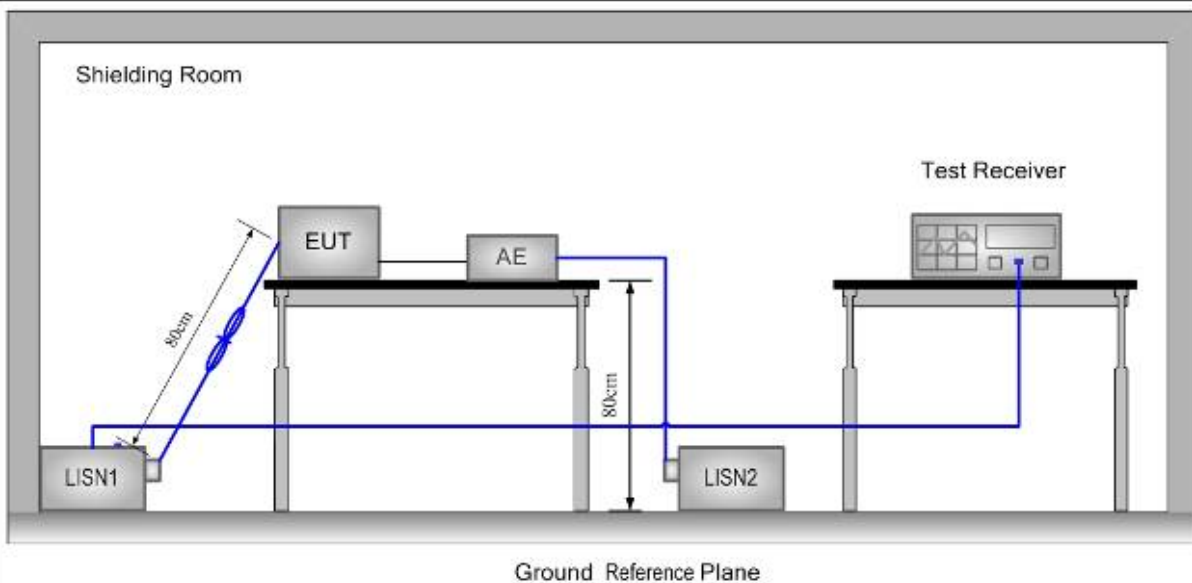

Test Procedure:

- 1) The mains terminal disturbance voltage was measured with the EUT in a shielded room.
- 2) The EUT was connected to AC power source through a LISN 1 (Line Impedance Stabilization Network) which provides $50\Omega/50\mu\text{H} + 5\Omega$ linear impedance. The power cables of all other units of the EUT were connected to a second LISN, which was bonded to the ground reference plane in the same way as the LISN for the unit being measured. A multiple socket outlet strip was used to connect multiple power cables to a single LISN provided the rating of the LISN was not exceeded.
- 3) The tabletop EUT was placed upon a non-metallic table 0.8m above the ground reference plane. And for floor-standing arrangement, the EUT was placed on the horizontal ground reference plane, but separated from metallic contact with the ground reference plane by 0.1m of insulation.
- 4) The test was performed with a vertical ground reference plane. The rear of the EUT shall be 0.4 m from the vertical ground reference plane. The vertical ground reference plane was bonded to the horizontal ground reference plane. The LISN was placed 0.8 m from the boundary of the unit under test and bonded to a ground reference plane for LISN mounted on top of the ground reference plane. This distance was between the closest points of the LISN and the EUT. The mains lead of EUT excess 0.8m was folded back and forth parallel to the lead so as to form a horizontal bundle with a length between 0.3m and 0.4m. All other units of the EUT and associated equipment were at least 0.8 m from the LISN.



Remark: Pre-scan was performed with peak detected on all ports, Quasi-peak & average measurements were performed at the frequencies at which maximum peak emission level were detected. Pretest under all modes; choose the worst case mode (in Middle channel) record on the report. Please see the attached Quasi-peak and Average test results.

Test Result: N/A

Test Data:

This EUT is powered by battery only; therefore the test on mains terminals is not applicable.

7.4 6dB Occupied Bandwidth

Test Configuration:

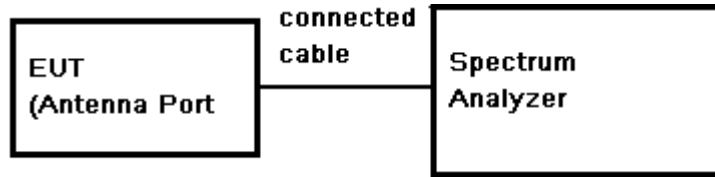

Test Procedure:

- 1). Place the EUT on the table and set it in transmitting mode.
- 2). Remove the antenna from the EUT and then connect a low loss RF cable from the antenna port to the spectrum analyzer.
- 3). Set the spectrum analyzer as RBW=100KHz, VBW≥3* RBW, Span=3MHz, Sweep=auto
- 4). Mark the peak frequency and -6dB (upper and lower) frequency.
- 5). Repeat above procedures until all frequency measured was complete.

Limit:

≥ 500 kHz

Test date:

Test Channel	6dB Bandwidth (KHz)	Limit (KHz)	Test Result
Lowest	1545	500	Pass
Middle	1610	500	Pass
Highest	1585	500	Pass

Test plot as follows:

Test channel: Lowest

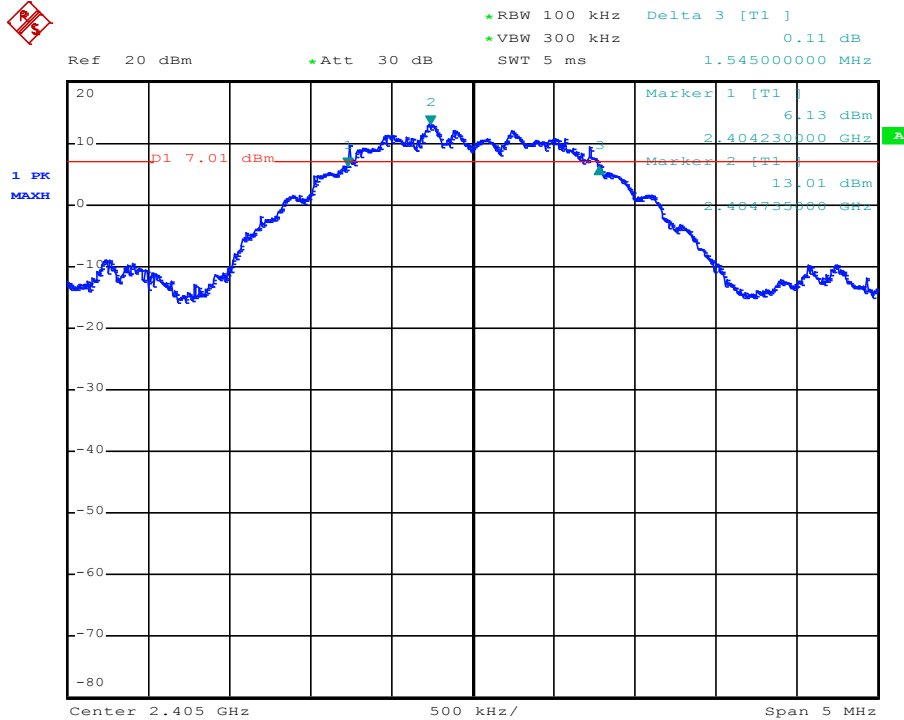

Test channel: Middle

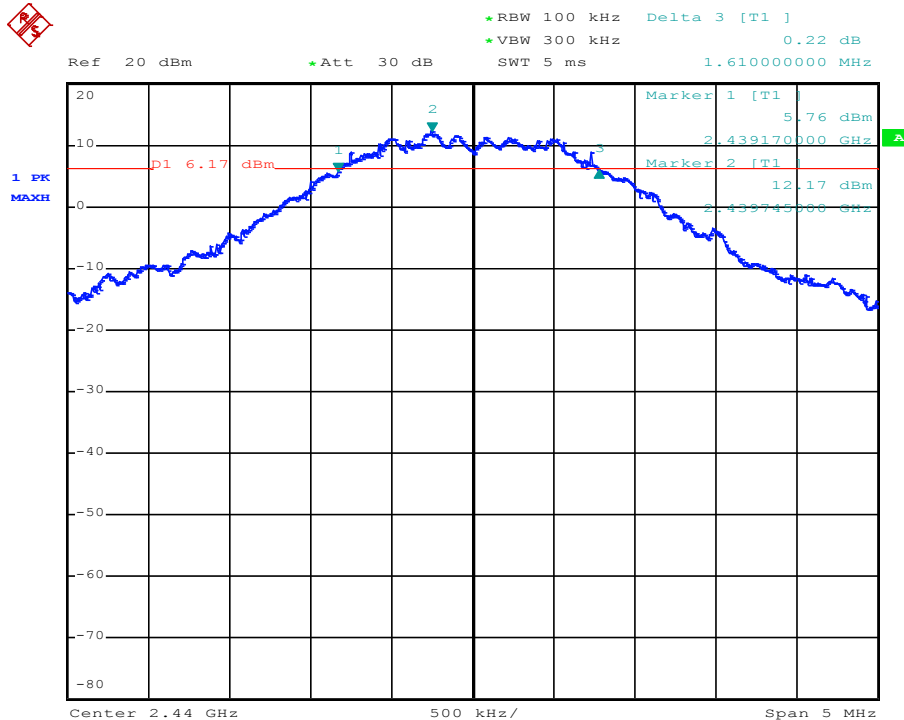

Test channel: Highest

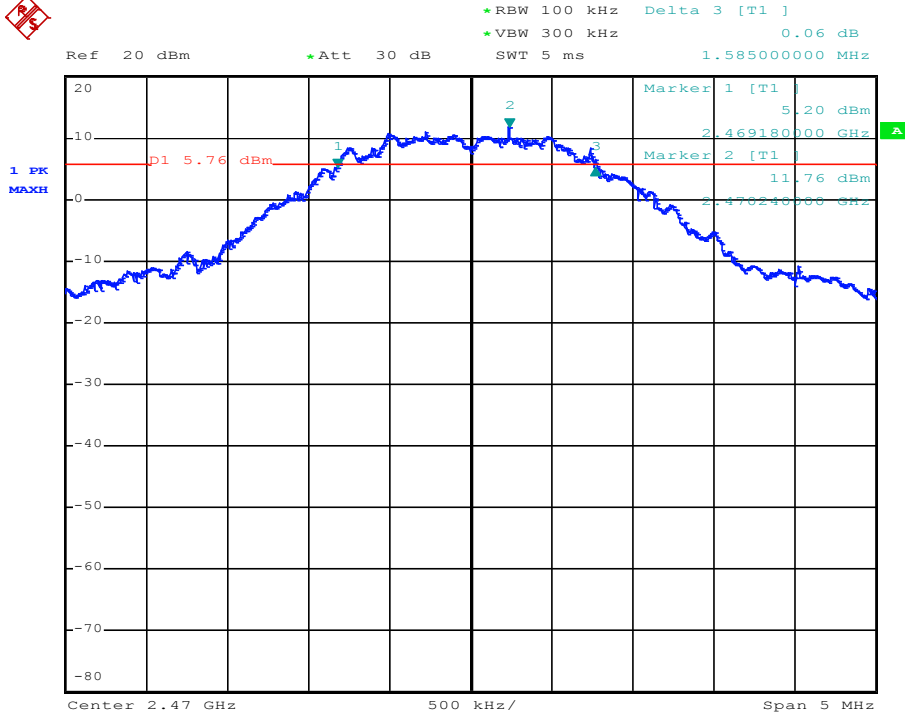

7.5 Conducted Peak Output Power

Test Configuration:

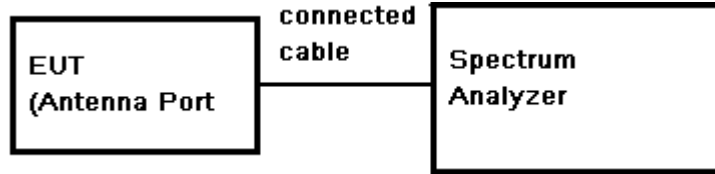

Test Procedure:

- 1) Place the EUT on the table and set it in transmitting mode.
- 2) Remove the antenna from the EUT and then connect a low loss RF cable from the antenna port to the spectrum.
- 3) Set the spectrum analyzer: RBW = 3 MHz, VBW = 3 MHz, Span= fully encompass the bandwidth, Sweep = auto; Detector Function = Peak Trace mode=max hold
- 4) Use the peak marker function to determine the maximum amplitude level within the RBW.
- 5) Record the max. Power reading.
- 6) Repeat above procedures until all the frequency measured were complete.

Test Limit: 30dBm

Test data:

Test Channel	Reading Power (dBm)	Cable Loss (dB)	Output Power (dBm)	Limit (dBm)	Test Result
Lowest	15.92	0.5	16.42	30	Pass
Middle	15.97	0.5	16.47	30	Pass
Highest	15.01	0.5	15.51	30	Pass

Output Power = Reading Power + Cable Loss

Test plot as follows:

Test channel: Lowest

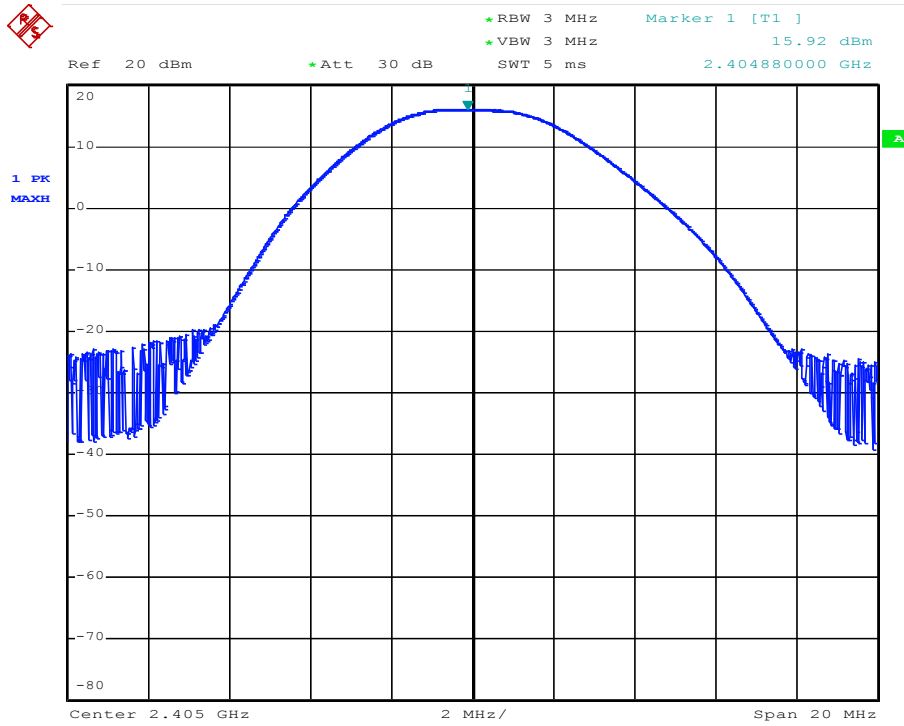

Test channel: Middle

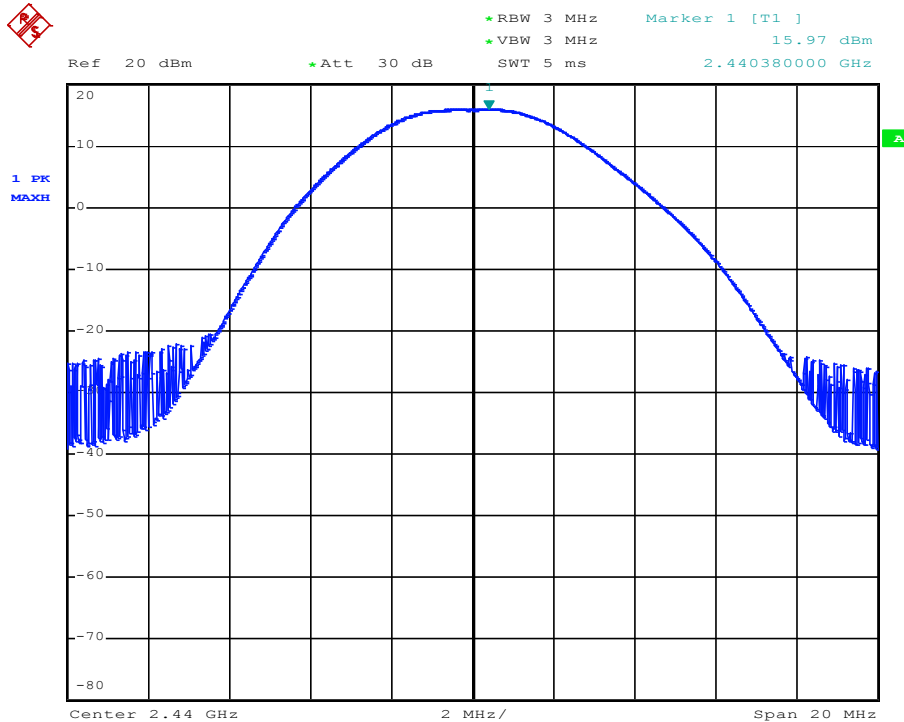

Test channel: Highest



+ RBW 3 MHz Marker 1 [T1]
 + VBW 3 MHz 15.01 dBm
 SWT 5 ms 2.470520000 GHz

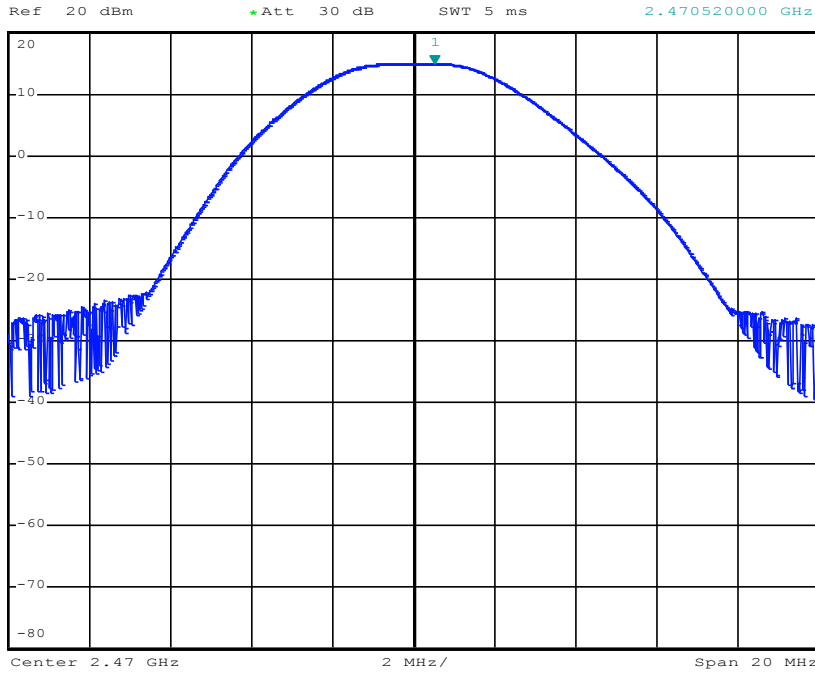

7.6 Peak Power Spectral Density

Test Configuration:

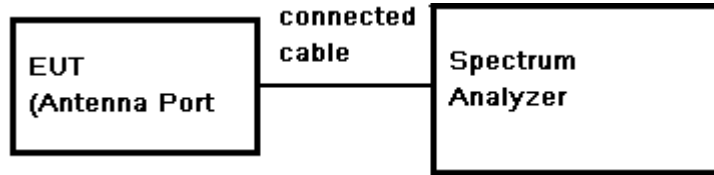

Test Procedure:

- 1) Remove the antenna from the EUT and then connect a low RF cable from the antenna port to the spectrum.
- 2) Set the spectrum analyzer: Center Frequency= Channel Frequency, RBW = 3 kHz VBW = 10 kHz. Span= 1.5 times the DTS bandwidth, Sweep = auto; Detector = Peak; Trace mode=max hold, Trace=Max hold.
- 3) Use the peak marker function to determine the maximum amplitude level within the RBW.
- 4) Record the marker level for the particular mode.
- 5) Repeat these steps for other channel and modes.

Test Limit:

8dBm/3kHz

Test data:

Test Channel	Reading (dBm/3KHz)	Cable Loss	PSD (dBm/3KHz)	Limit (dBm/3KHz)	Test Result
Lowest	3.33	0.5	3.83	8	Pass
Middle	2.76	0.5	3.26	8	Pass
Highest	1.59	0.5	2.09	8	Pass

RF Power Density = Reading Power + Cable Loss

Test plot as follows:

Test channel: Lowest

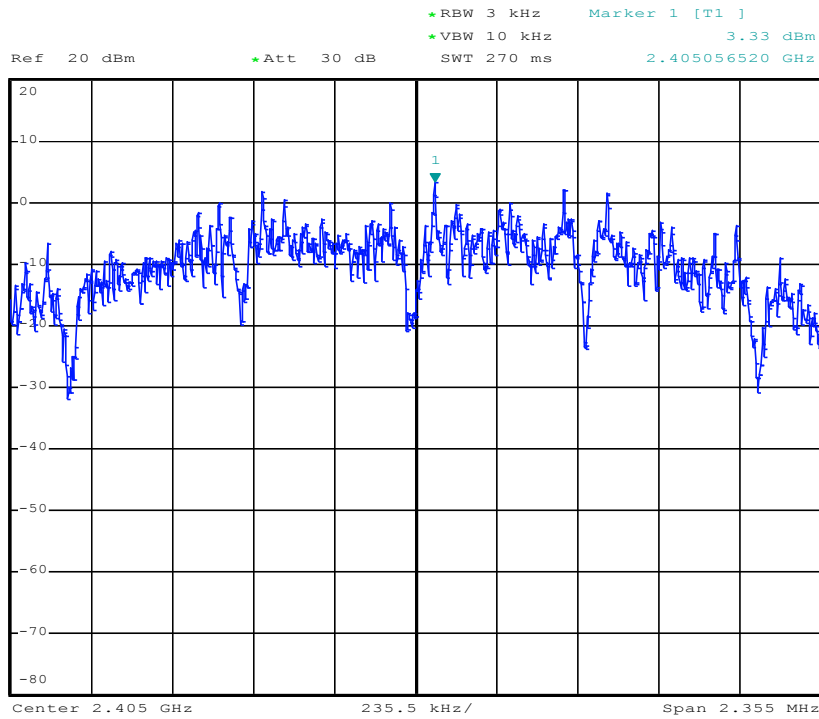

Test channel: Middle

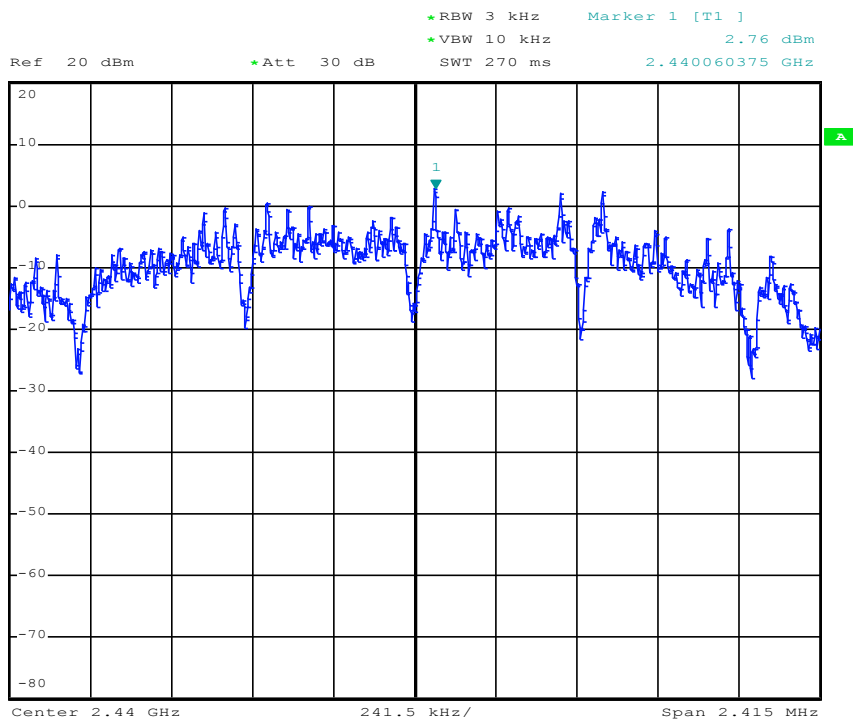

Test channel: Highest

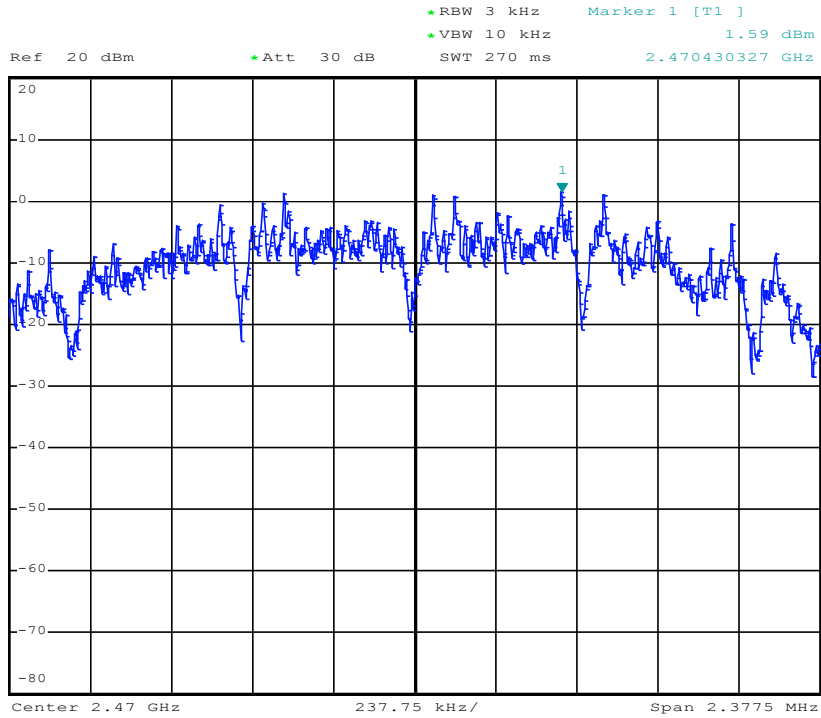

7.7 Conducted Spurious Emissions and Band edge

Test Configuration:

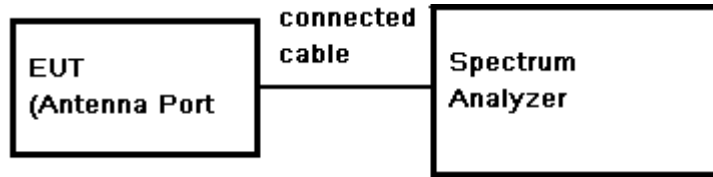

Test Procedure:

- 1) Remove the antenna from the EUT and then connect a low RF cable from the antenna port to the spectrum.
- 2) Set the spectrum analyzer: RBW = 100 KHz. VBW = 300 KHz. Sweep = auto; Detector Function = Peak (Max. hold).
- 3) Measurement were investigated while operating in MIMO mode, however, it was determined that single antenna operation produced the worst emissions. Since the data of MIMO mode are not report.

Limit:

- (d) In any 100 kHz bandwidth outside the frequency band in which the spread spectrum or digitally modulated intentional radiator is operating, the radio frequency power that is produced by the intentional radiator shall be at least 20 dB below that in the 100 kHz bandwidth within the band that contains the Highest level of the desired power, based on either an RF conducted or a radiated measurement, provided the transmitter demonstrates compliance with the peak conducted power limits.

7.7.1 Conducted Spurious Emissions

Test plot as follows:

Test channel: Lowest

30MHz-3GHz:

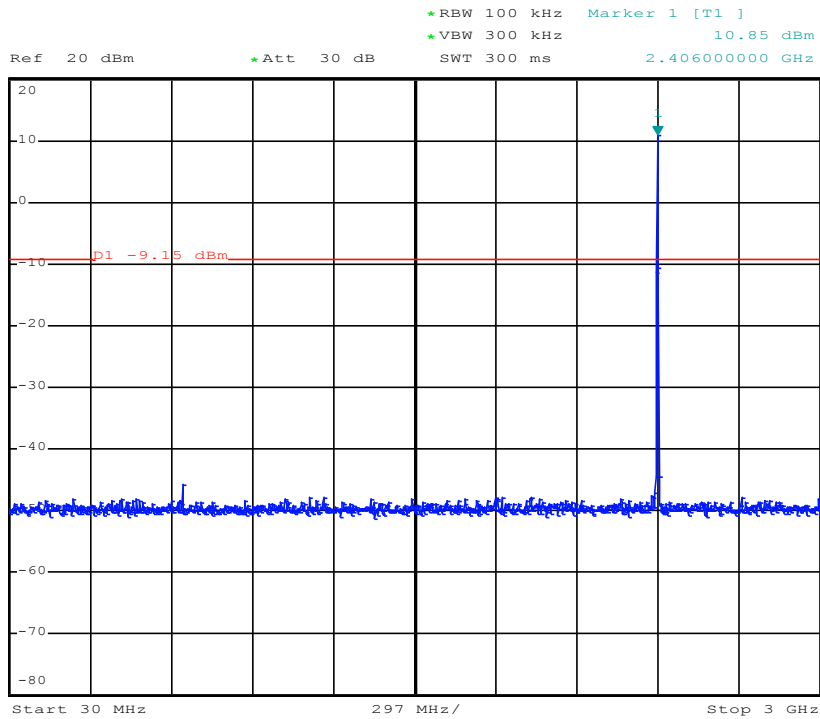

3GHz-25GHz:

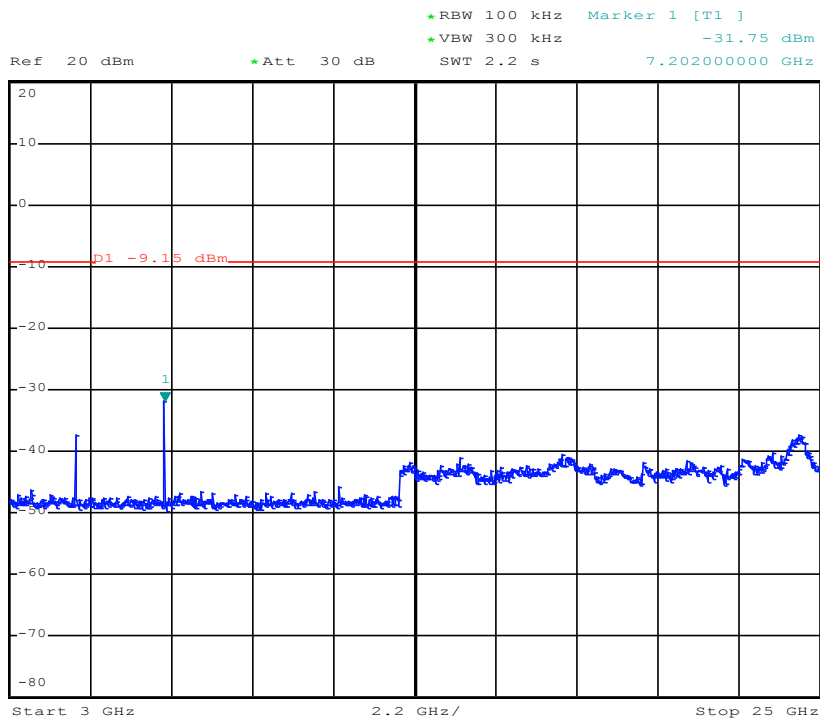

7.7.2 Conducted Band-edge
Test plot as follows:

Test channel: Lowest

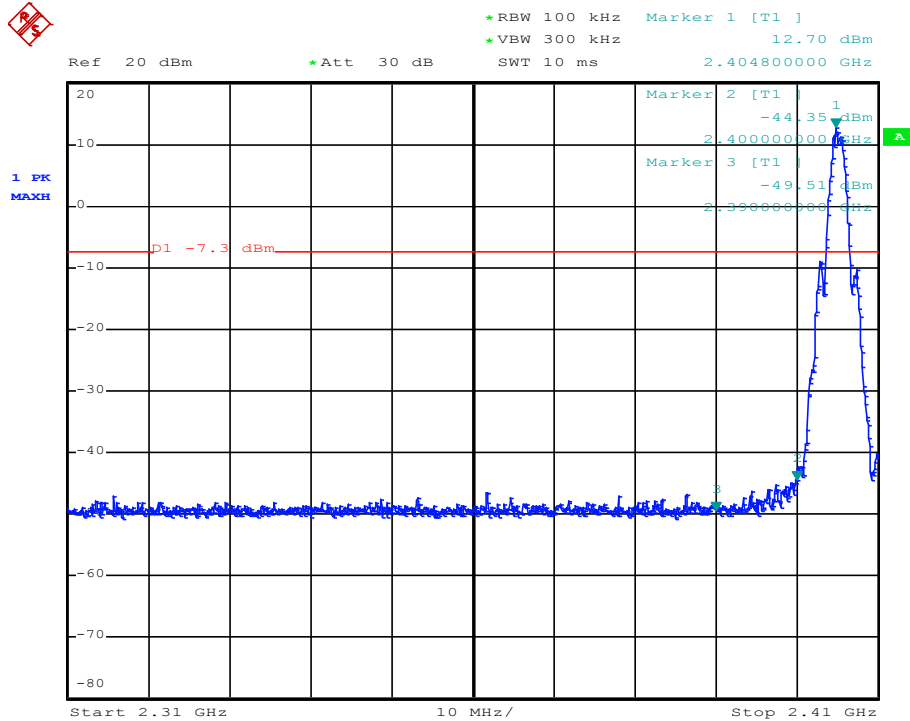

Test channel: Highest

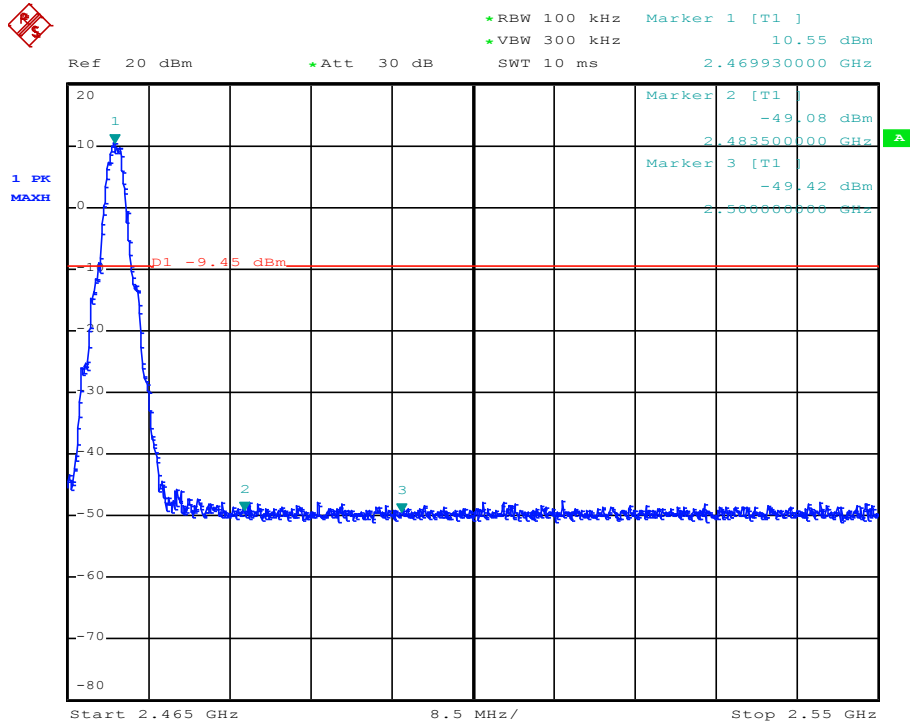

7.8 Radiated Spurious Emissions and Band-edge

Frequency Range: 9KHz to 25GHz

Test site/setup: Measurement Distance: 3m
Test instrumentation set-up:

Frequency Range	Detector	RBW	VBW
0.009MHz-0.090MHz	Peak	10kHz	30kHz
0.009MHz-0.090MHz	Average	10kHz	30kHz
0.090MHz-0.110MHz	Quasi-peak	10kHz	30kHz
0.110MHz-0.490MHz	Peak	10kHz	30kHz
0.110MHz-0.490MHz	Average	10kHz	30kHz
0.490MHz -30MHz	Quasi-peak	10kHz	30kHz
30MHz-1GHz	Quasi-peak	100kHz	300kHz
Above 1GHz	Peak	RBW=1MHz	VBW≥RBW
	Average		VBW=10Hz

Sweep=Auto

15.209 Limit:

Frequency	Field strength (microvolt/meter)	Limit (dBuV/m)
0.009MHz-0.490MHz	2400/F(KHz)	128.5 ~ 93.8
0.490MHz-1.705MHz	24000/F(KHz)	73.8 ~63.0
1.705MHz-30MHz	30	69.5
30MHz-88MHz	100	40.0
88MHz-216MHz	150	43.5
216MHz-960MHz	200	46.0
960MHz-1GHz	500	54.0
Above 1GHz	500	54.0

Note: 15.35(b), Unless otherwise specified, the limit on peak radio frequency emissions is 20dB above the maximum permitted average emission limit applicable to the equipment under test. This peak limit applies to the total peak emission level radiated by the device.

Test Configuration: Receive antenna scan height 1 m - 4 m. polarization Vertical / Horizontal

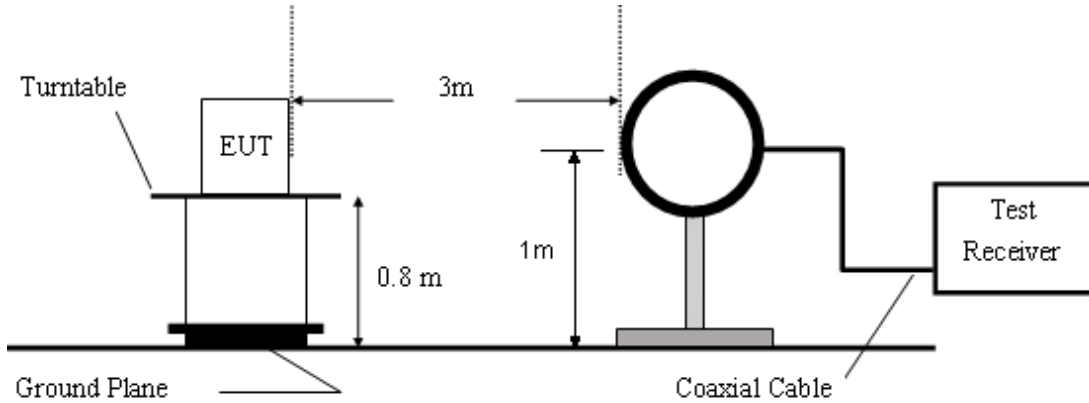

Figure1. Below 30MHz radiated emissions test configuration

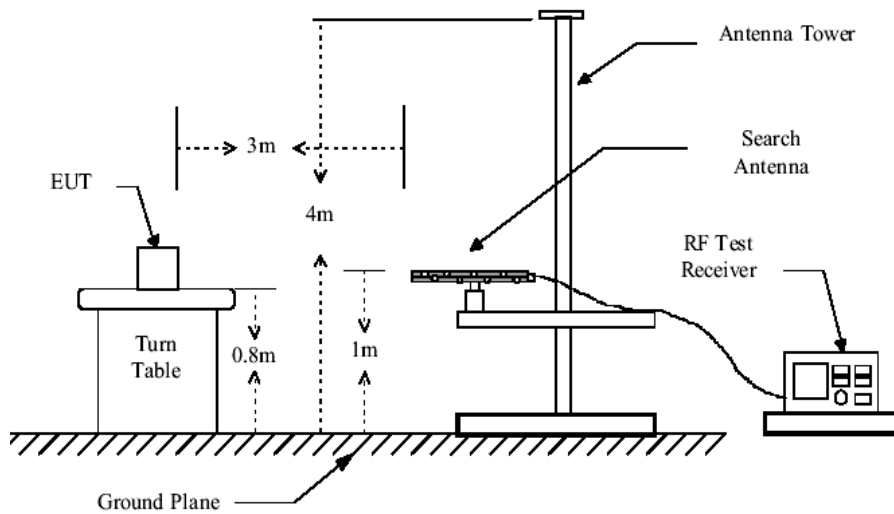

Figure 2. 30MHz to 1GHz radiated emissions test configuration

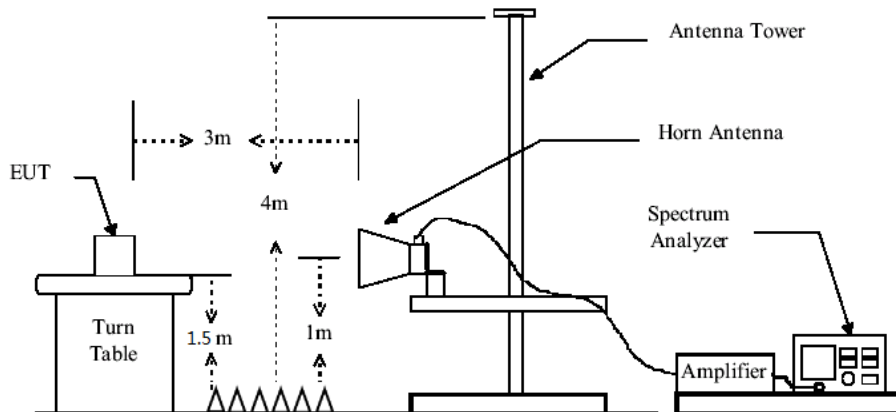

Figure 3. Above 1GHz radiated emissions test configuration

- Test Procedure:**
- 1) The procedure used was ANSI Standard C63.10. The receiver was scanned from 9 KHz to 25GHz. When an emission was found, the table was rotated to produce the maximum signal strength. An initial pre-scan was performed for in peak detection mode using the receiver. The EUT was measured for both the Horizontal and Vertical polarities and performed a pre-test three orthogonal planes. For intentional radiators, measurements of the variation of the input power or the radiated signal level of the fundamental frequency component of the emission, as appropriate, shall be performed with the supply voltage varied between 85% and 115% of the nominal rated supply voltage. The worst case emissions were reported.
 - 2) Low noise amplifier was used below 1GHz, High pass Filter was used above 3GHz. We did not use any amplifier or filter between 1G and 3GHz.
 - 3) Test were performed for their spatial orthogonal(X, Y, Z), the worst test data (X orthogonal) was submitted.
 - a) For this intentional radiator operates below 25 GHz. the spectrum shall be investigated to the tenth harmonic of the highest fundamental frequency. And above the third harmonic of this intentional radiator, the disturbance is very low. So the test result only displays to 5rd harmonic.
 - b) As shown in Section, for frequencies above 1000MHz. the above field strength limits are based on average limits. However, the peak field strength of any emission shall not exceed the maximum permitted average limits specified above by more than 20 dB under any condition of modulation.
 - 4) No spurious emissions were detected within 20dB of limit below 30MHz.

Test Result: Pass

7.8.1 Radiated Spurious Emissions

30MHz-1GHz:

lowest Channel

Item	Freq.	Read Level	Antenna Factor	Preamp Factor	Cable Loss	Result Level	Limit Line	Over Limit	Detector	Polarization
(Mark)	(MHz)	(dBμV)	(dB/m)	(dB)	(dB)	(dBμV/m)	(dBμV/m)	(dB)		
1	124.55	45.39	11.85	35.25	1.24	23.23	43.50	-20.27	QP	Horizontal
2	175.94	61.51	11.47	36.00	1.48	38.46	43.50	-5.04	QP	Horizontal
3	300.05	54.61	13.50	35.80	2.06	34.37	46.00	-11.63	QP	Horizontal
4	320.62	53.88	13.26	35.68	2.13	33.59	46.00	-12.41	QP	Horizontal
5	432.82	47.26	16.11	35.75	2.54	30.16	46.00	-15.84	QP	Horizontal
6	808.23	35.21	23.58	35.07	3.65	27.37	46.00	-18.63	QP	Horizontal
1	41.53	43.82	13.81	35.80	0.62	22.45	40.00	-17.55	QP	Vertical
2	84.73	51.37	8.63	35.72	1.01	25.29	40.00	-14.71	QP	Vertical
3	168.72	63.98	12.19	35.64	1.45	41.98	43.50	-1.52	QP	Vertical
4	299.35	50.76	13.40	35.83	2.06	30.39	46.00	-15.61	QP	Vertical
5	652.76	40.14	20.35	34.57	3.21	29.13	46.00	-16.87	QP	Vertical
6	819.31	35.62	23.69	34.92	3.68	28.07	46.00	-17.93	QP	Vertical

Result Level = Read Level + Antenna Factor + Cable loss - Preamp Factor

Below is the plot of worst case on lowest channel:
Vertical:

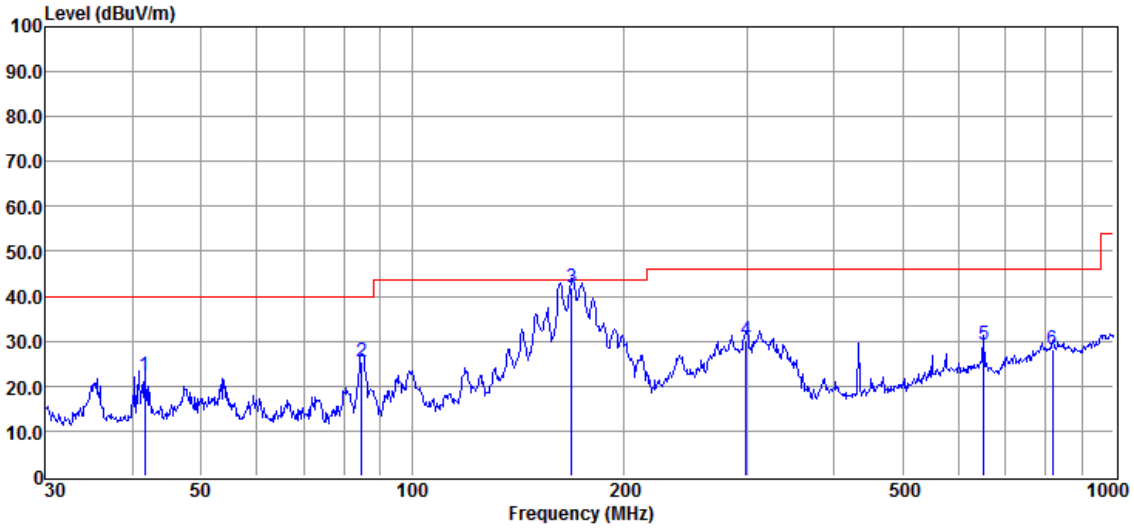

Horizontal:

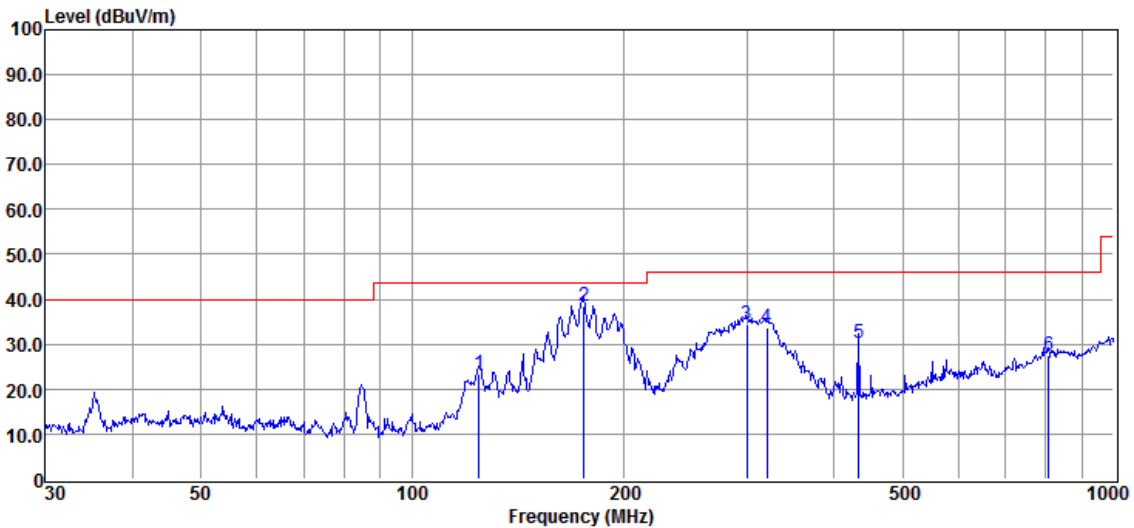

Above 1GHz:

Lowest Channel

Mark	Frequency (MHz)	Reading (dBuV)	Factor (dB)	Emission (dBuV/m)	Limit (dBuV/m)	Over Limit (dB)	Detector	polarization
1	4810	53.18	6.2	59.38	74	-14.62	peak	Horizontal
2	4810	45.28	6.2	51.48	54	-2.52	AVG	Horizontal
3	7215	43.25	10.67	53.92	74	-20.08	peak	Horizontal
4	7215	39.74	10.67	50.41	54	-3.59	AVG	Horizontal
5	9620	33.44	14.37	47.81	74	-26.19	peak	Horizontal
6	4810	60.09	6.2	66.29	74	-7.71	peak	Vertical
7	4810	45.32	6.2	51.52	54	-2.48	AVG	Vertical
8	7215	58.17	10.67	68.84	74	-5.16	peak	Vertical
9	7215	40.98	10.67	51.65	54	-2.35	AVG	Vertical
10	9620	35.41	14.37	49.78	74	-24.22	peak	Vertical

Middle Channel

Mark	Frequency (MHz)	Reading (dBuV)	Factor (dB)	Emission (dBuV/m)	Limit (dBuV/m)	Over Limit (dB)	Detector	polarization
1	4880	51.66	6.95	58.61	74	-15.39	peak	Horizontal
2	4880	44.53	6.95	51.48	54	-2.52	AVG	Horizontal
3	7320	52.95	11.13	64.08	74	-9.92	peak	Horizontal
4	7320	41.15	11.13	52.28	54	-1.72	AVG	Horizontal
5	9760	31.98	14.35	46.33	74	-27.67	peak	Horizontal
6	4880	54.24	6.95	61.19	74	-12.81	peak	Vertical
7	4880	43.89	6.95	50.84	54	-3.16	AVG	Vertical
8	7320	57.51	11.13	68.64	74	-5.36	peak	Vertical
9	7320	40.66	11.13	51.79	54	-2.21	AVG	Vertical
10	9760	33.67	14.35	48.02	74	-25.98	peak	Vertical

Highest Channel

Mark	Frequency (MHz)	Reading (dBuV)	Factor (dB)	Emission (dBuV/m)	Limit (dBuV/m)	Over Limit (dB)	Detector	polarization
1	4940	51.84	7.37	59.21	74	-14.79	peak	Horizontal
2	4940	43.39	7.37	50.76	54	-3.24	AVG	Horizontal
3	7410	55.02	11.53	66.55	74	-7.45	peak	Horizontal
4	7410	40.74	11.53	52.27	54	-1.73	AVG	Horizontal
5	9880	31.83	14.39	46.22	74	-27.78	peak	Horizontal
6	4940	56.97	7.37	64.34	74	-9.66	peak	Vertical
7	4940	43.48	7.37	50.85	54	-3.15	AVG	Vertical
8	7410	56.58	11.53	68.11	74	-5.89	peak	Vertical
9	7410	40.37	11.53	51.9	54	-2.1	AVG	Vertical
10	9880	32.7	14.39	47.09	74	-26.91	peak	Vertical

Remark: 1) Emission = Receiver Reading + Factor

2) Factor = Antenna Factor + Cable Loss + Pre-amplifier Factor.

3) If the Peak value below the AV Limit, the AV test doesn't perform for this submission.

**7.8.2 Radiated Band-edge
Lowest Channel**

MK.	Frequency (MHz)	Reading (dBuV/m)	Corrected factor(dB)	Result (dBuV/m)	Limit (dBuV/m)	Over Limit (dB)	Detector	Polarization
1	2383.1	56.67	-3.87	52.8	74	-21.2	Peak	Horizontal
2	2390	54.58	-3.89	50.69	74	-23.31	Peak	Horizontal
3	2405.7	108.32	-3.93	104.39	74	30.39	Peak	Horizontal
1	2357.6	34.72	-3.8	30.92	54	-23.08	Average	Horizontal
2	2390	34.08	-3.89	30.19	54	-23.81	Average	Horizontal
3	2405.5	73.89	-3.93	69.96	54	15.96	Average	Horizontal

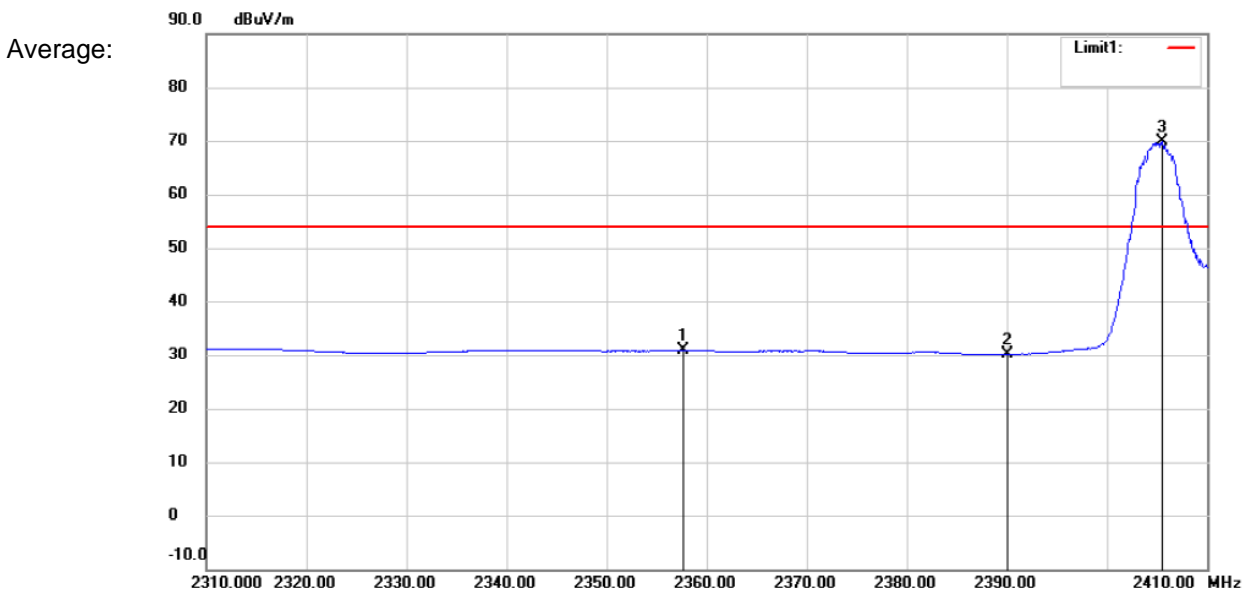
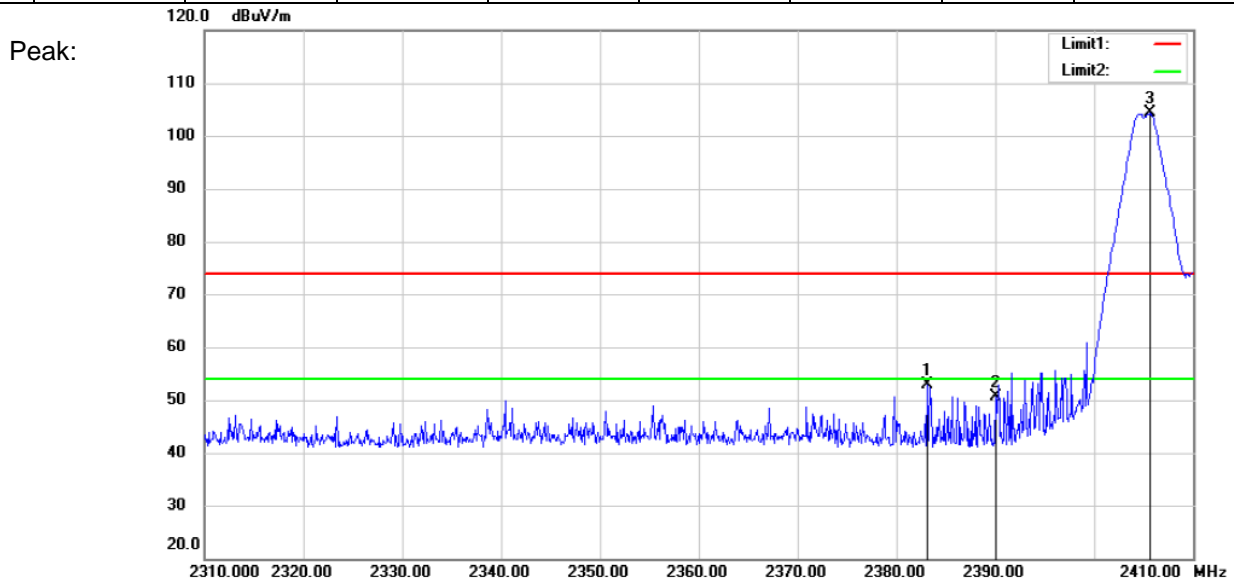

Lowest Channel

MK.	Frequency (MHz)	Reading (dBuV/m)	Corrected factor(dB)	Result (dBuV/m)	Limit (dBuV/m)	Over Limit (dB)	Detector	Polarization
1	2388.8	62.01	-3.89	58.12	74	-15.88	Peak	Vertical
2	2390	50.91	-3.89	47.02	74	-26.98	Peak	Vertical
3	2405.6	112.24	-3.93	108.31	74	34.31	Peak	Vertical
1	2365.6	35.59	-3.81	31.78	54	-22.22	Average	Vertical
2	2390	34.81	-3.89	30.92	54	-23.08	Average	Vertical
3	2405.1	87.29	-3.92	83.37	54	29.37	Average	Vertical

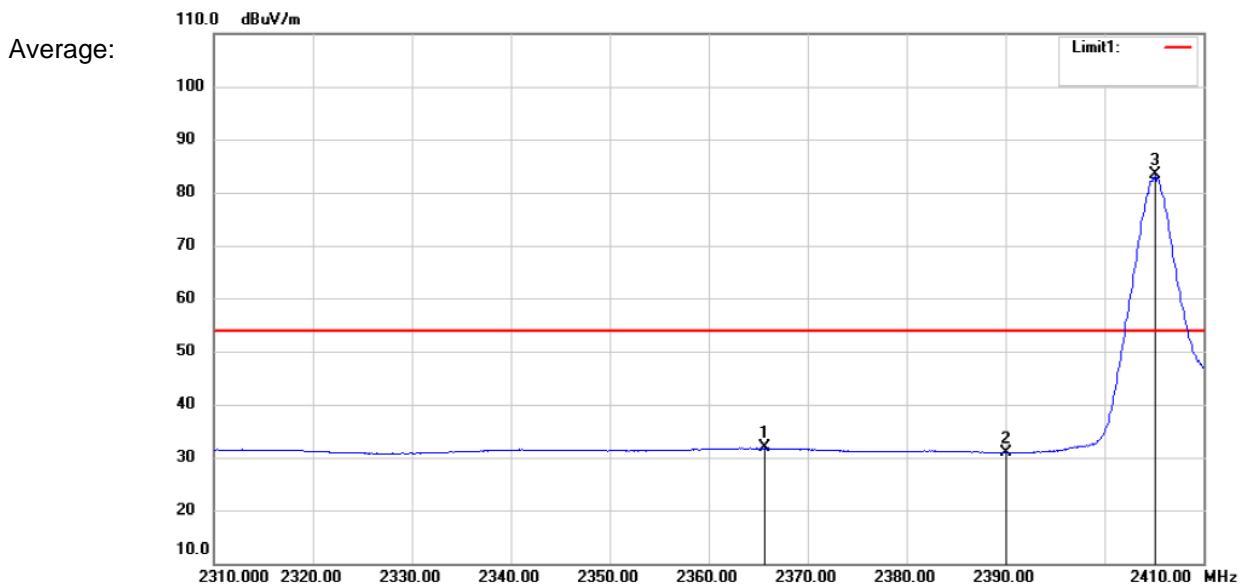
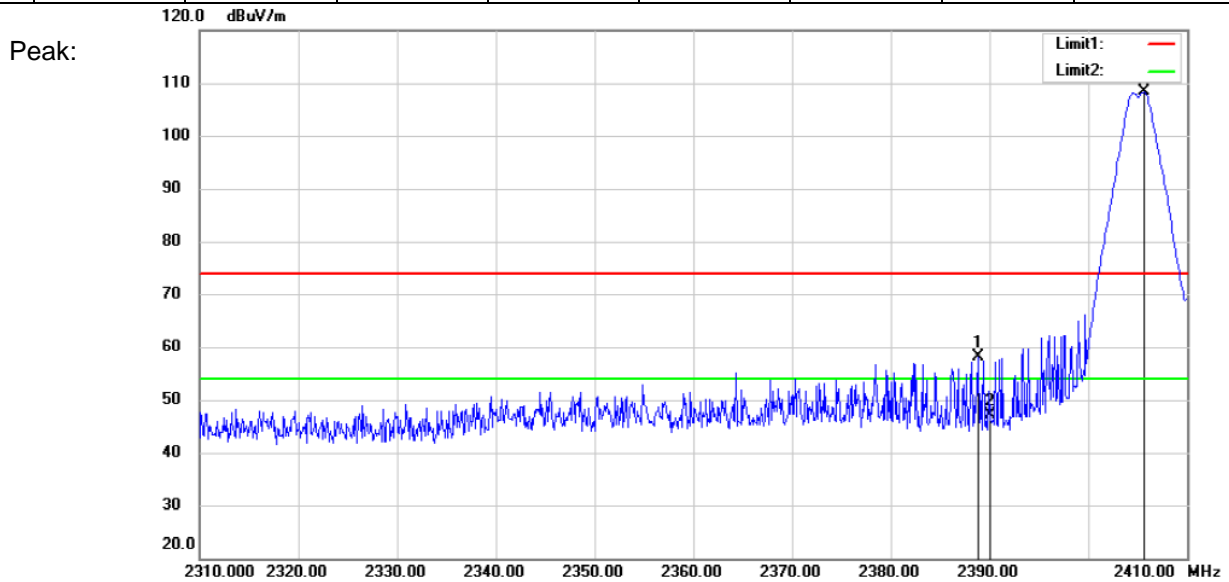

Highest Channel

MK.	Frequency (MHz)	Reading (dBuV/m)	Corrected factor(dB)	Result (dBuV/m)	Limit (dBuV/m)	Over Limit (dB)	Detector	Polarization
1	2469.59	110.26	-4	106.26	74	32.26	Peak	Horizontal
2	2483.5	46.04	-4.01	42.03	74	-31.97	Peak	Horizontal
3	2500	46.84	-4.03	42.81	74	-31.19	Peak	Horizontal
1	2469.845	84.85	-4	80.85	54	26.85	Average	Horizontal
2	2483.5	34.74	-4.01	30.73	54	-23.27	Average	Horizontal
3	2500	34.43	-4.03	30.4	54	-23.6	Average	Horizontal

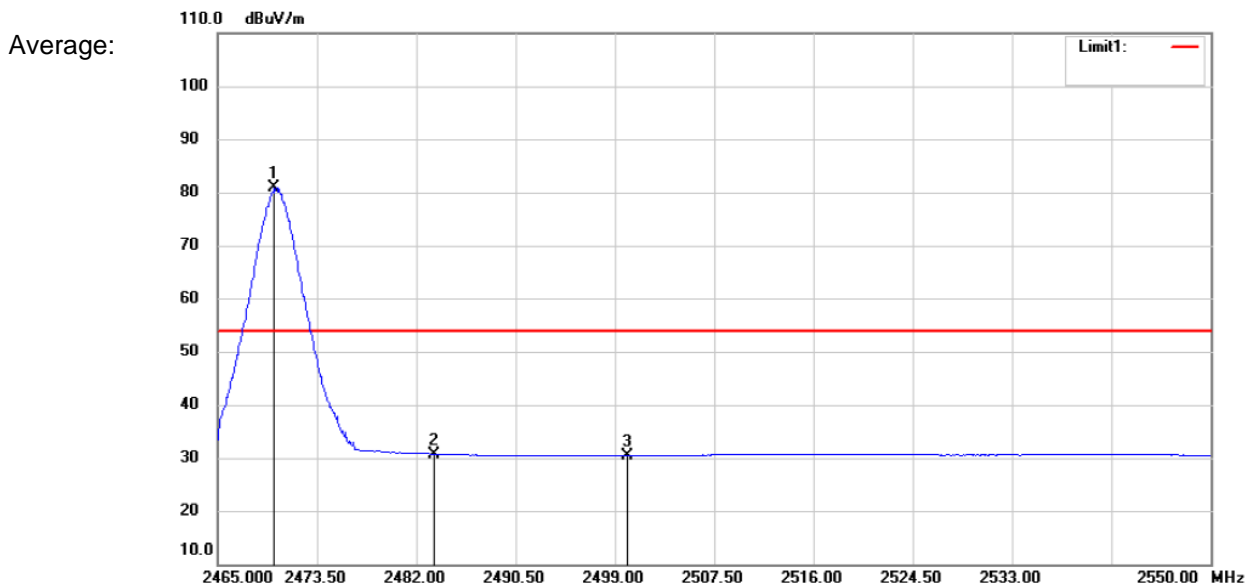
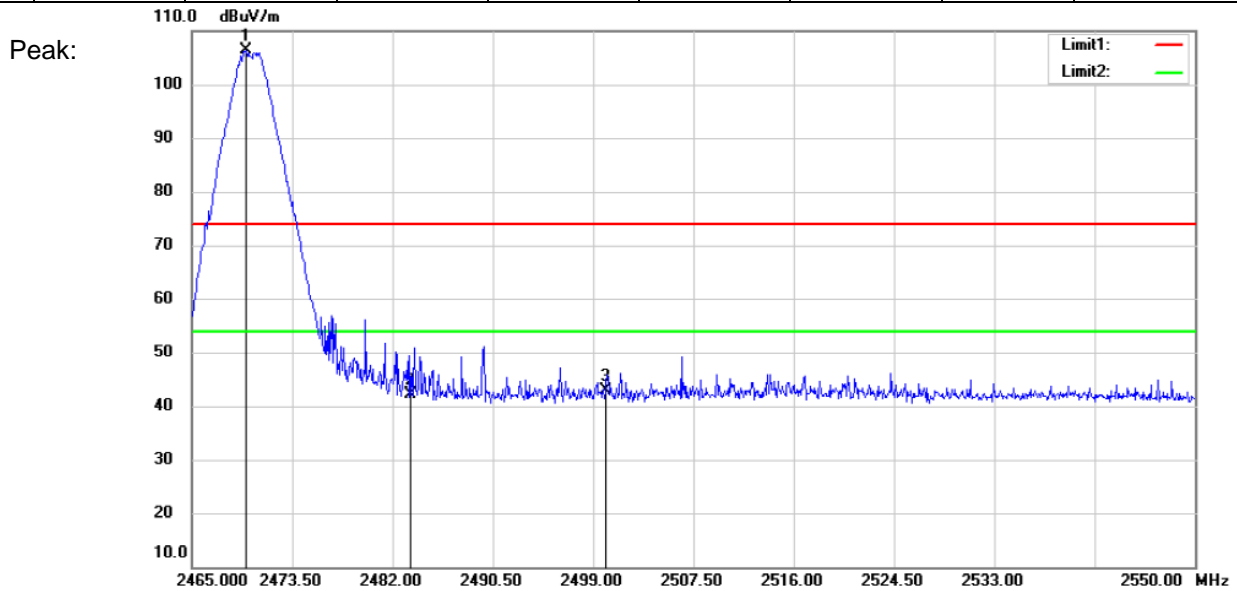

Highest Channel

MK.	Frequency (MHz)	Reading (dBuV/m)	Corrected factor(dB)	Result (dBuV/m)	Limit (dBuV/m)	Over Limit (dB)	Detector	Polarization
1	2469.59	112.41	-4	108.41	74	34.41	Peak	Vertical
2	2483.5	52.45	-4.01	48.44	74	-25.56	Peak	Vertical
3	2500	45.74	-4.03	41.71	74	-32.29	Peak	Vertical
1	2469.845	87.66	-4	83.66	54	29.66	Average	Vertical
2	2483.5	34.68	-4.01	30.67	54	-23.33	Average	Vertical
3	2500	34.41	-4.03	30.38	54	-23.62	Average	Vertical

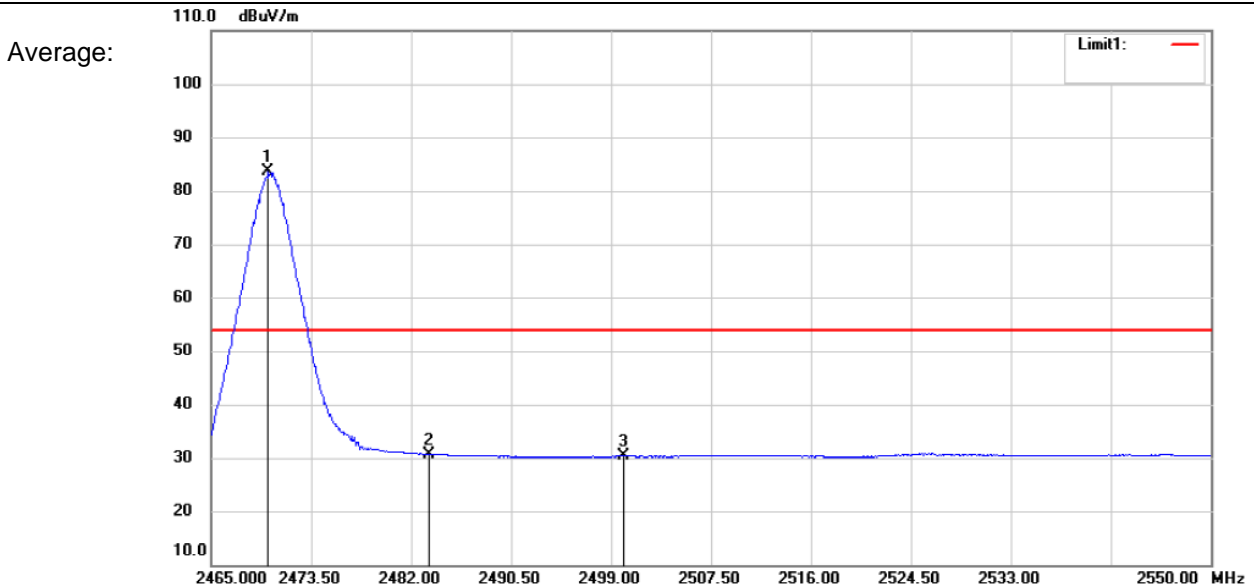
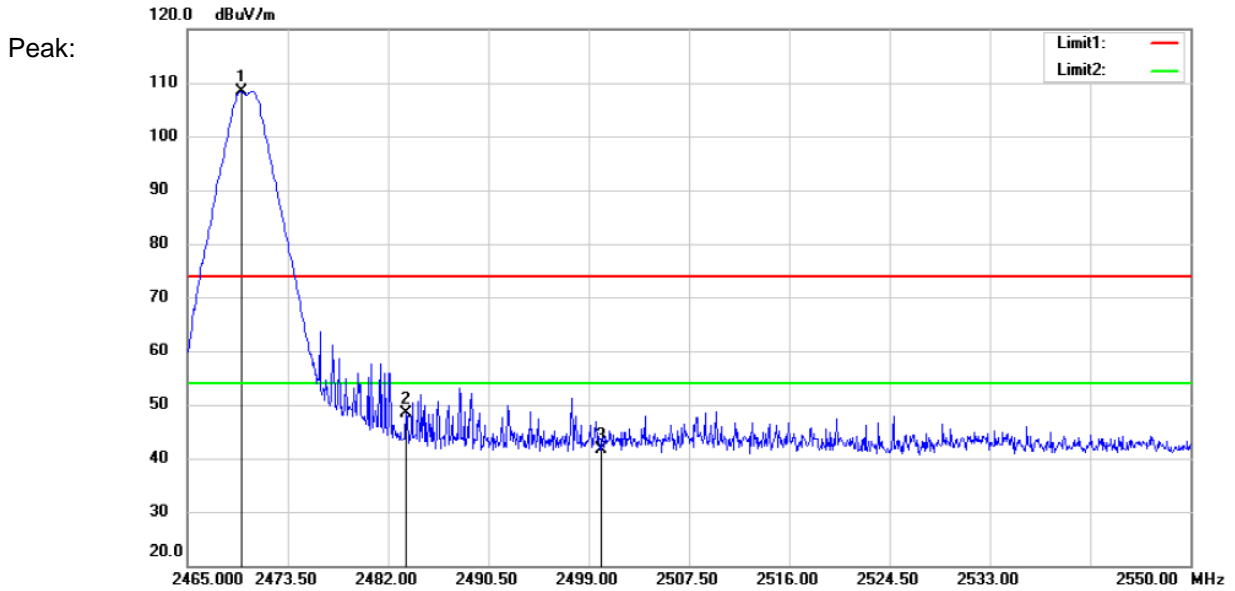

Remark: 1). Test Level = Receiver Reading + Antenna Factor + Cable Loss- Preamplifier Factor
2). If the Peak value below the AV Limit, the AV test doesn't perform for this submission.

All frequencies within the "Restricted bands" have been evaluated to compliance. Except as shown in paragraph of this section, only spurious emissions are permitted in any of the frequency bands listed below:

a. FCC Part 15, Subpart C Section 15.205 Restricted bands of operation.

MHz	MHz	MHz	GHz
0.090 - 0.110	16.42 - 16.423	399.9 - 410	4.5 - 5.15
10.495 - 0.505	16.69475 - 16.69525	608 - 614	5.35 - 5.46
2.1735 - 2.1905	16.80425 - 16.80475	960 - 1240	7.25 - 7.75
4.125 - 4.128	25.5 - 25.67	1300 - 1427	8.025 - 8.5
4.17725 - 4.17775	37.5 - 38.25	1435 - 1626.5	9.0 - 9.2
4.20725 - 4.20775	73 - 74.6	1645.5 - 1646.5	9.3 - 9.5
6.215 - 6.218	74.8 - 75.2	1660 - 1710	10.5 - 12.7
6.26775 - 6.26825	108 - 121.94	1718.8 - 1722.2	13.25 - 13.4
6.31175 - 6.31225	123 - 138	2200 - 2300	14.47 - 14.5
8.291 - 8.294	149.9 - 150.05	2310 - 2390	15.35 - 16.2
8.362 - 8.366	156.52475 - 156.52525	2483.5 - 2500	17.7 - 21.4
8.37625 - 8.38675	156.7 - 156.9	2655 - 2900	22.01 - 23.12
8.41425 - 8.41475	162.0125 - 167.17	3260 - 3267	23.6 - 24.0
12.29 - 12.293	167.72 - 173.2	3332 - 3339	31.2 - 31.8
12.51975 - 12.52025	240 - 285	3345.8 - 3358	36.43 - 36.5
12.57675 - 12.57725	322 - 335.4	3600 - 4400	
13.36 - 13.41			

b. RSS-Gen section 7.2.2 Restricted bands of operation

MHz	MHz	GHz
0.090-0.110	240-285	9.0-9.2
2.1735-2.1905	322-335.4	9.3-9.5
3.020-3.026	399.9-410	10.6-12.7
4.125-4.128	608-614	13.25-13.4
4.17725-4.17775	960-1427	14.47-14.5
4.20725-4.20775	1435-1626.5	15.35-16.2
5.677-5.683	1645.5-1646.5	17.7-21.4
6.215-6.218	1660-1710	22.01-23.12
6.26775-6.26825	1718.8-1722.2	23.6-24.0
6.31175-6.31225	2200-2300	31.2-31.8
8.291-8.294	2310-2390	36.43-36.5
8.362-8.366	2655-2900	Above 38.6
8.37625-8.38675	3260-3267	
8.41425-8.41475	3332-3339	
12.29-12.293	3345.8-3358	
12.51975-12.52025	3500-4400	
12.57675-12.57725	4500-5150	
13.36-13.41	5350-5460	
16.42-16.423	7250-7750	
16.69475-16.69525	8025-8500	
16.80425-16.80475		
25.5-25.67		
37.5-38.25		
73-74.6		
74.8-75.2		
108-138		
156.52475-156.52525		
156.7-156.9		

7.1 99% Occupied Bandwidth

Test Configuration:

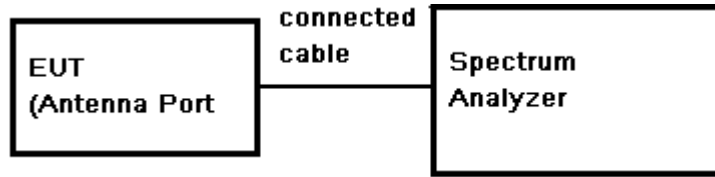

Test Procedure:

- 1) Place the EUT on the table and set it in transmitting mode.
- 2) Remove the antenna from the EUT and then connect a low loss RF cable from the antenna port to the spectrum analyzer.
- 3) Set the spectrum analyzer: Span = approximately 2 to 3 times the 20dB bandwidth, RBW \geq 1% of the 20dB bandwidth. VBW \geq RBW. Sweep = auto; Detector Function = Peak. Trace = Max Hold.
- 4) Mark the peak frequency and 99% bandwidth points.
- 5) Repeat above procedures until all frequency measured was complete.

Limit:

\geq 500 kHz

Test date:

Test Channel	Test Frequency (MHz)	Bandwidth (MHz)
Lowest	2402	2.700
Middle	2440	3.005
Highest	2470	2.905

Test plot as follows:

Test channel: Lowest

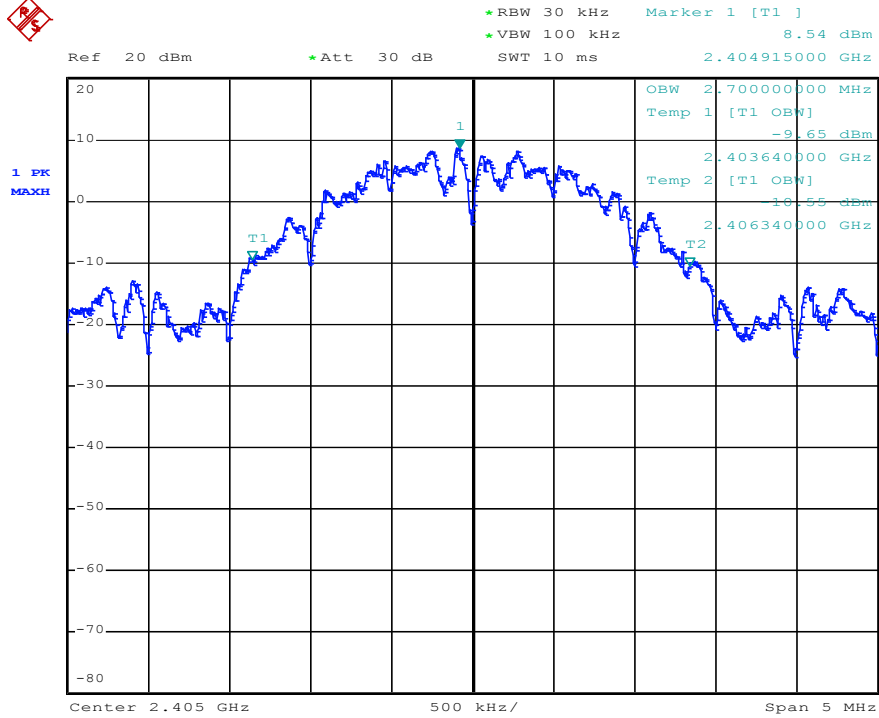

Test channel: Middle

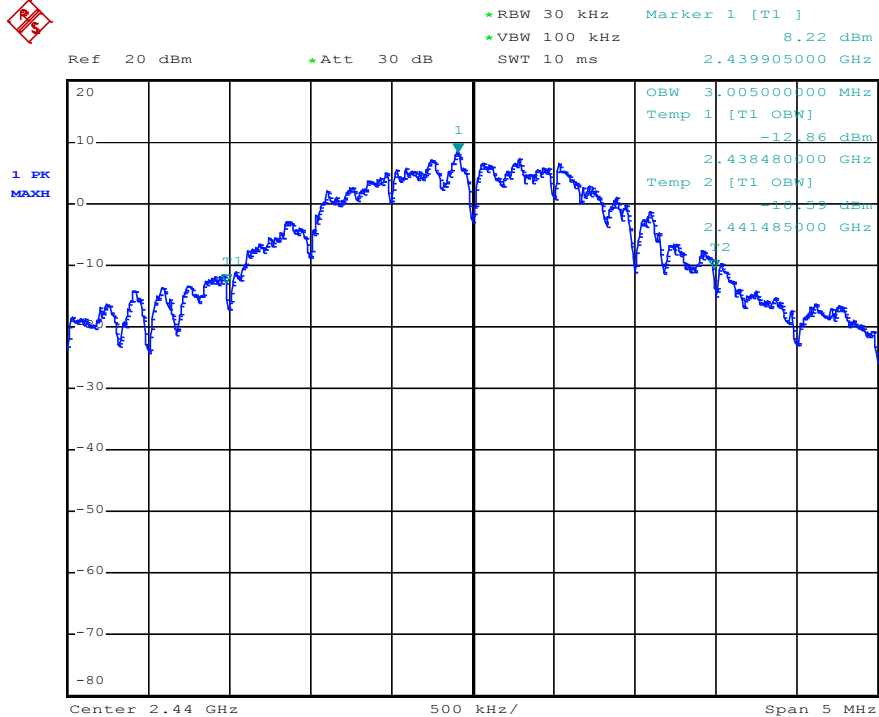

Test channel: Highest

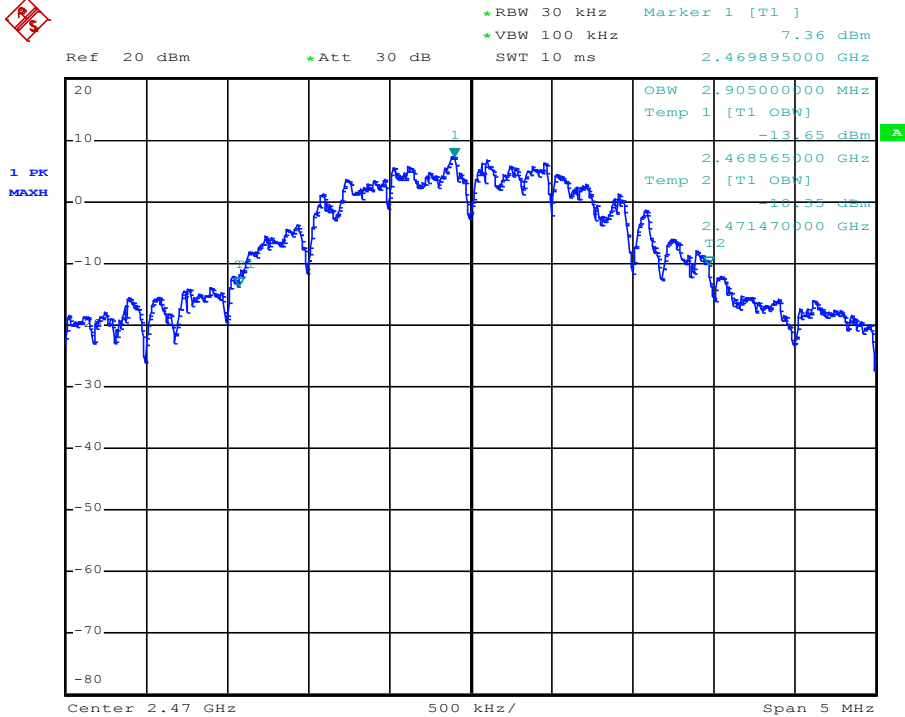



8 Test Setup Photographs

Refer to the < Test Setup photos-FCC>.

9 EUT Constructional Details

Refer to the < External Photos> & < Internal Photos>.

--End of the Report--