

MATERIAL: 0.01" MATT POLYCARBONATE, UV STABILIZED

ADHESIVE: 3M DOUBLE COATED TAPE 9495LE  
 Total Thickness : 0.15mm  
 300LSE (Faceside and Backside)

GRAPHICS: SEE ADOBE ILLUSTRATOR FILE  
 ET33\_APPDEC\_A.ai

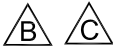

COLOUR : BLACK GRAPHICS ON WHITE BACKGROUND

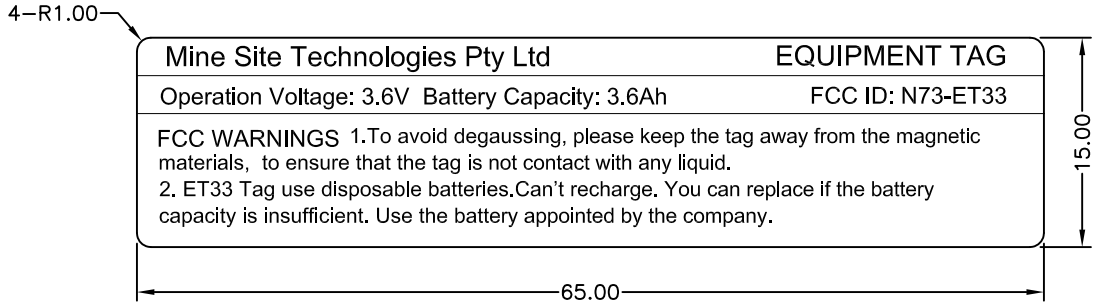

**NOTE:**  
 THIS DECAL DOES NOT HAVE A BLACK BORDER.  
 DECAL TO BE CUT WITH ROUNDED CORNERS (SEE RADIUS ABOVE).

**INFORMATION:**  
 THIS LABEL MUST BE UV STABILIZED AS IT WILL BE USED IN APPLICATION EXPOSED TO WEATHERING AND UV .  
 THIS IMPLIES THE USE OF UV-RESISTANT INK , UV-RESISTANT BASE MATERIAL OR A SPECIAL SURFACE TREATMENT IF THE USE OF A NON-UV RESISTANT MATERIAL IS CONSIDERED ( SUCH AS COATING FOR ENHANCED UV AND WEATHERING RESISTANCE )

<b>TOLERANCE INFORMATION</b> UNLESS OTHERWISE MARKED LENGTH, WIDTH, LOCATION/POSITIONING AND GEOMETRY = ±0.10mm. ALL ANGLES ±0.5°. ALL DIMENSIONS ARE IN mm.		REV	ECO	REVISION NOTE	DRN	APP	DATE	 <p><b>MINE SITE TECHNOLOGIES PTY. LTD.</b>                  LEVEL 5 - 113 WICKS ROAD                  NORTH RYDE NSW 2113                  Phone: +61-2-9491-6500                  Fax: +61-2-9870-8270</p>	PRODUCT	<b>EQUIPMENT TAG</b>		
SCALE: DRAWING NOT TO SCALE		A		ORIGINAL	CL		20-03-15		ASPECT	<b>Approval Decal</b>		
		B		Change the FCC ID with"-"	CL		07-05-15		SHOWING	<b>FABRICATION DETAILS</b>		
		C		Change the FCC ID to be "N73-ET33"	CL		11-06-15		DRAWING/CAD REFERENCE	REV	DATE	
		D							<b>ET33_APPDEC_FD</b>	<b>C</b>	<b>11-Jun-2015</b>	
		E										<b>SHEET 1 OF 1</b>
		F										
G												

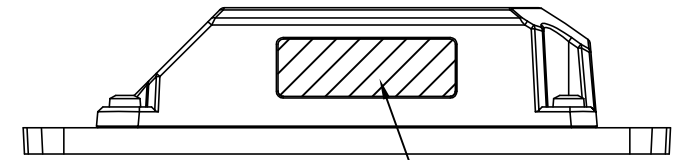
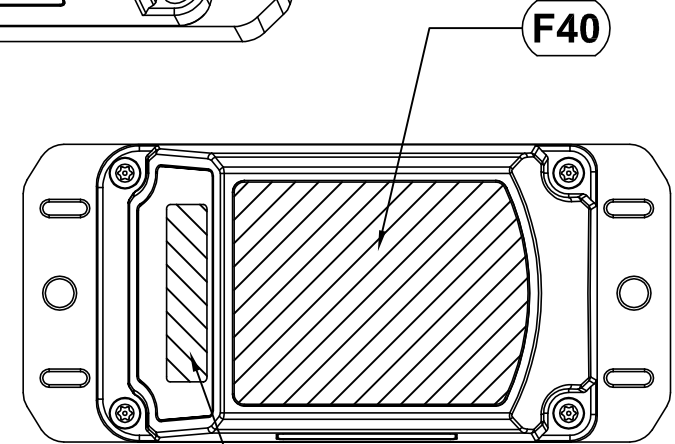
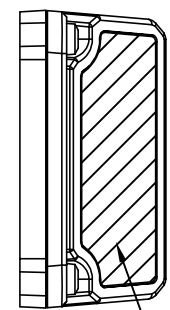
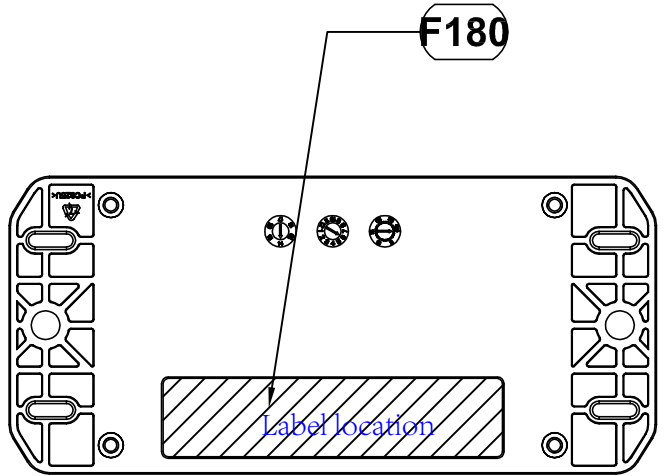
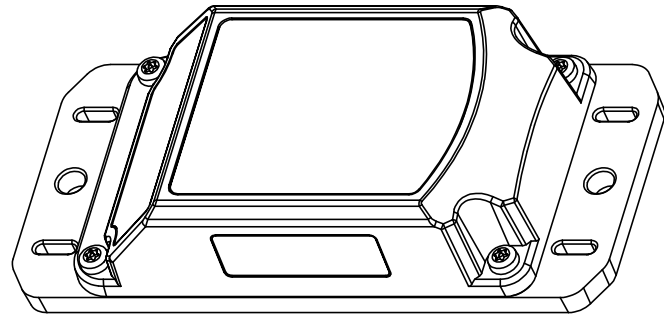

**LABEL LIST**

ITEM	DESCRIPTION
F40	TOP DECAL
F50	FRONT DECAL
F160	SERIAL NUMBER DECAL
F170	MAC ADDRESS DECAL
F180	APPROVAL DECAL

TOLERANCE INFORMATION

UNLESS OTHERWISE MARKED  
 LENGTH, WIDTH, LOCATION/POSITIONING AND GEOMETRY = ±0.10mm.  
 ALL ANGLES ±0.5°.  
 ALL DIMENSIONS ARE IN mm.

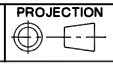

SCALE: DRAWING NOT TO SCALE

REV	ECO	REVISION NOTE	DRN	APP	DATE
A		ORIGINAL	CL		30-12-14
B					
C					
D					
E					
F					
G					



**MINE SITE TECHNOLOGIES PTY. LTD.**  
 LEVEL 5 - 113 WICKS ROAD  
 NORTH RYDE NSW 2113  
 Phone: +61-2-9491-6500  
 Fax: +61-2-9870-8270

PRODUCT		EQUIPMENT TAG	
ASPECT	SHOWING	Tag decal placement information	
DRAWING/CAD REFERENCE		REV	DATE
ET33_DEC2_ASS		A	30-Dec-2014
		SHEET 1 OF 1	