

## **Certification Test Report**

**FCC ID: N6SGCM  
IC: 827B-GCM**

**FCC Rule Part: 15.225  
IC Radio Standards Specification: RSS-210**

**ACS Report Number: 11-0087.W06.11.A**

**Manufacturer: Gilbarco, Inc.  
Model: FlexPay Contactless**

**Test Begin Date: April 11, 2011  
Test End Date: April 12, 2011**

**Report Issue Date: May 10, 2011**



FOR THE SCOPE OF ACCREDITATION UNDER LAB Code 200612-0

This report must not be used by the client to claim product certification, approval, or endorsement by NVLAP, NIST, or any agency of the Federal Government.

Prepared by: \_\_\_\_\_

**Kirby Munroe  
Director, Wireless Certifications  
ACS, Inc.**

This test report shall not be reproduced except in full. This report may be reproduced in part with prior written consent of ACS, Inc. The results contained in this report are representative of the sample(s) submitted for evaluation.

**This report contains 17 pages**

# TABLE OF CONTENTS

<b>1</b>	<b>GENERAL</b> .....	<b>3</b>
1.1	PURPOSE.....	3
1.2	PRODUCT DESCRIPTION .....	3
1.3	TEST METHODOLOGY AND CONSIDERATIONS .....	3
<b>2</b>	<b>TEST FACILITIES</b> .....	<b>4</b>
2.1	LOCATION .....	4
2.2	LABORATORY ACCREDITATIONS/RECOGNITIONS/CERTIFICATIONS .....	4
2.3	RADIATED EMISSIONS TEST SITE DESCRIPTION .....	5
2.3.1	<i>Semi-Anechoic Chamber Test Site</i> .....	5
2.3.2	<i>Open Area Tests Site (OATS)</i> .....	6
2.4	CONDUCTED EMISSIONS TEST SITE DESCRIPTION .....	7
<b>3</b>	<b>APPLICABLE STANDARD REFERENCES</b> .....	<b>7</b>
<b>4</b>	<b>LIST OF TEST EQUIPMENT</b> .....	<b>8</b>
<b>5</b>	<b>SUPPORT EQUIPMENT</b> .....	<b>9</b>
<b>6</b>	<b>EQUIPMENT UNDER TEST SETUP BLOCK DIAGRAM</b> .....	<b>9</b>
<b>7</b>	<b>SUMMARY OF TESTS</b> .....	<b>10</b>
7.1	ANTENNA REQUIREMENT – FCC: CFR 47 PART 15.203.....	10
7.2	POWER LINE CONDUCTED EMISSIONS – FCC: CFR 47 PART 15.207/ IC RSS-GEN 7.2.4.....	10
7.2.1	<i>Measurement Procedure</i> .....	10
7.2.2	<i>Measurement Results</i> .....	10
7.3	RADIATED EMISSIONS – INTENTIONAL RADIATION .....	12
7.3.1	<i>In-Band Emissions Limitations – FCC Part 15.225(a),(b),(c) / IC RSS-210 A2.6</i> .....	12
7.3.1.1	Test Methodology .....	12
7.3.1.2	Test Results .....	12
7.3.2	<i>Out-of-Band Emissions – FCC Part 15.225(d) / IC RSS-Gen 7.2.5</i> .....	13
7.3.2.1	Test Methodology .....	13
7.3.2.2	Distance Correction for Measurements Below 30 MHz – Part 15.31.....	13
7.3.2.3	Test Results .....	14
7.3.2.4	Sample Calculation: .....	14
7.4	OCCUPIED BANDWIDTH – FCC PART 15.215(c) / IC RSS-GEN 4.6.1 .....	15
7.4.1	<i>Test Methodology</i> .....	15
7.4.2	<i>Test Results</i> .....	15
7.5	FREQUENCY STABILITY – FCC CFR 47 PART 15.225(E) / IC RSS-210 A2.6.....	16
7.5.1	<i>Test Methodology</i> .....	16
7.5.2	<i>Test Results</i> .....	16
<b>8</b>	<b>CONCLUSION</b> .....	<b>17</b>

## **1 GENERAL**

### **1.1 Purpose**

The purpose of this report is to demonstrate compliance with Part 15 Subpart C of the FCC's Code of Federal Regulations and Industry Canada's Radio Standards Specification RSS-210 for single modular approval.

### **1.2 Product description**

The Flexpay Contactless is a Contactless Smart Card Interface. It acts as a reader for ISO14443 Type A&B Proximity cards. As is common to such readers, card operation (as the card has no battery) and data reception requires constant carrier transmission where Card to Reader data modulation is performed by the card modulation the load it represents to the reader antenna.

Frequency Range: 13.56 MHz

Operating channels: 1

Modulation: AM

Operating Voltage: 24VDC

Applicant Information:

Gilbarco Inc.

7300 West Friendly Ave.

Greensboro NC 27420

Test Sample Serial Number(s): ACS#1

Test Sample Condition: The test sample was provided in working order with no visible defects.

### **1.3 Test Methodology and Considerations**

The EUT was tested in a configuration representative of typical installation for radiated emissions. No deviations from the test specifications were made.

## **2 TEST FACILITIES**

### **2.1 Location**

The radiated and conducted emissions test sites are located at the following address:

Advanced Compliance Solutions  
5015 B.U. Bowman Drive  
Buford, GA 30518  
Phone: (770) 831-8048  
Fax: (770) 831-8598

### **2.2 Laboratory Accreditations/Recognitions/Certifications**

ACS is accredited to ISO/IEC 17025 by the National Institute of Standards and Technology under their National Voluntary Laboratory Accreditation Program (NVLAP), Lab Code 200612-0. Unless otherwise specified, all tests methods described within this report are covered under the ISO/IEC 17025 scope of accreditation.

The Semi-Anechoic Chamber Test Site, Open Area Test Site (OATS) and Conducted Emissions Site have been fully described, submitted to, and accepted by the FCC, Industry Canada and the Japanese Voluntary Control Council for Interference by information technology equipment.

FCC Registration Number: 894540  
Industry Canada Lab Code: IC 4175A-1  
VCCI Member Number: 1831

- VCCI OATS Registration Number R-1526
- VCCI Conducted Emissions Site Registration Number: C-1608

## 2.3 Radiated Emissions Test Site Description

### 2.3.1 Semi-Anechoic Chamber Test Site

The Semi-Anechoic Chamber Test Site consists of a 20' x 30' x 18' shielded enclosure. The chamber is lined with Toyo Ferrite Grid Absorber, model number FFG-1000. The ferrite tile grid is 101 x 101 x 19mm thick and weighs approximately 550 grams. These tiles are mounted on steel panels and installed directly on the inner walls of the chamber.

The turntable is 150cm in diameter and is located 160cm from the back wall of the chamber. The chamber is grounded via 1 - 8' copper ground rod, installed at the center of the back wall, it is bound to the ground plane using 3/4" stainless steel braided cable.

The turntable is all steel, flush mounted table installed in an all steel frame. The table is remotely operated from inside the control room located 25' from the range. The turntable is electrically bonded to the surrounding ground plane via steel fingers installed on the edge of the turn table. The steel fingers make constant contact with the ground plane during operation.

Behind the turntable is a 3' x 6' x 4' deep shielded pit used for support equipment if necessary. The pit is equipped with 1 - 4" PVC chases from the turntable to the pit that allow for cabling to the EUT if necessary. The underside of the turntable can be accessed from the pit so cables can be supplied to the EUT from the pit.

A diagram of the Semi-Anechoic Chamber Test Site is shown in Figure 2.3-1 below:

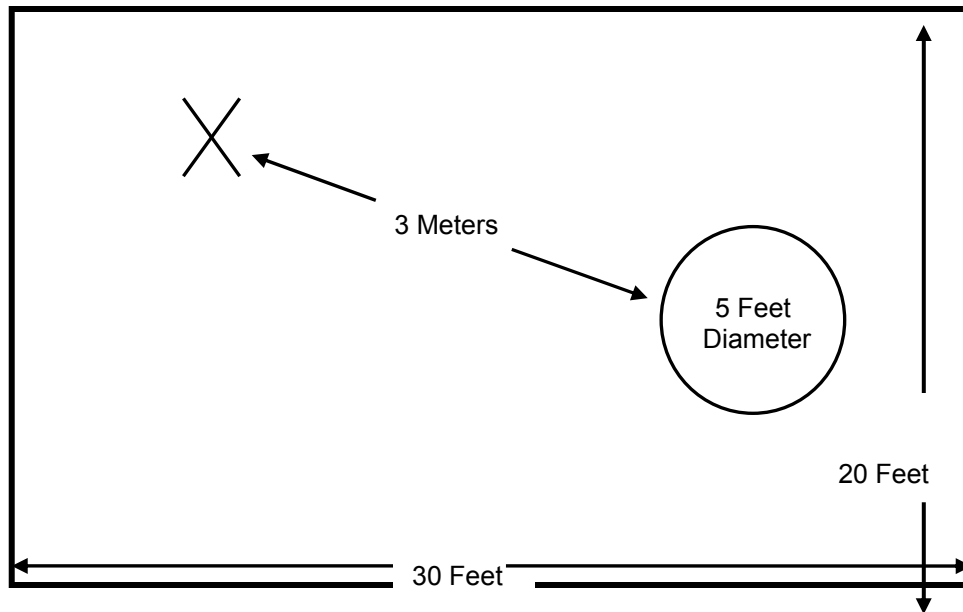

Figure 2.3-1: Semi-Anechoic Chamber Test Site

**2.3.2 Open Area Tests Site (OATS)**

The open area test site consists of a 40' x 66' concrete pad covered with a perforated electro-plated galvanized sheet metal. The perforations in the sheet metal are 1/8" holes that are staggered every 3/16". The individual sheets are placed to overlap each other by 1/4" and are riveted together to provide a continuous seam. Rivets are spaced every 3" in a 3 x 20 meter perimeter around the antenna mast and EUT area. Rivets in the remaining area are spaced as necessary to properly secure the ground plane and maintain the electrical continuity.

The entire ground plane extends 12' beyond the turntable edge and 16' beyond the antenna mast when set to a 10 meter measurement distance. The ground plane is grounded via 4 - 8' copper ground rods, each installed at a corner of the ground plane and bound to the ground plane using 3/4" stainless steel braided cable.

The turntable is an all aluminum 10' flush mounted table installed in an all aluminum frame. The table is remotely operated from inside the control room located 40' from the range. The turntable is electrically bonded to the surrounding ground plane via steel fingers installed on the edge of the turn table. The steel fingers make constant contact with the ground plane during operation.

Adjacent to the turntable is a 7' x 7' square and 4' deep concrete pit used for support equipment if necessary. The pit is equipped with 5 - 4" PVC chases from the pit to the control room that allow for cabling to the EUT if necessary. The underside of the turntable can be accessed from the pit so cables can be supplied to the EUT from the pit. The pit is covered with 2 sheets of 1/4" diamond style re-enforced steel sheets. The sheets are painted to match the perforated steel ground plane; however the underside edges have been masked off to maintain the electrical continuity of the ground plane. All reflecting objects are located outside of the ellipse defined in ANSI C63.4.

A diagram of the Open Area Test Site is shown in Figure 2.3-2 below:

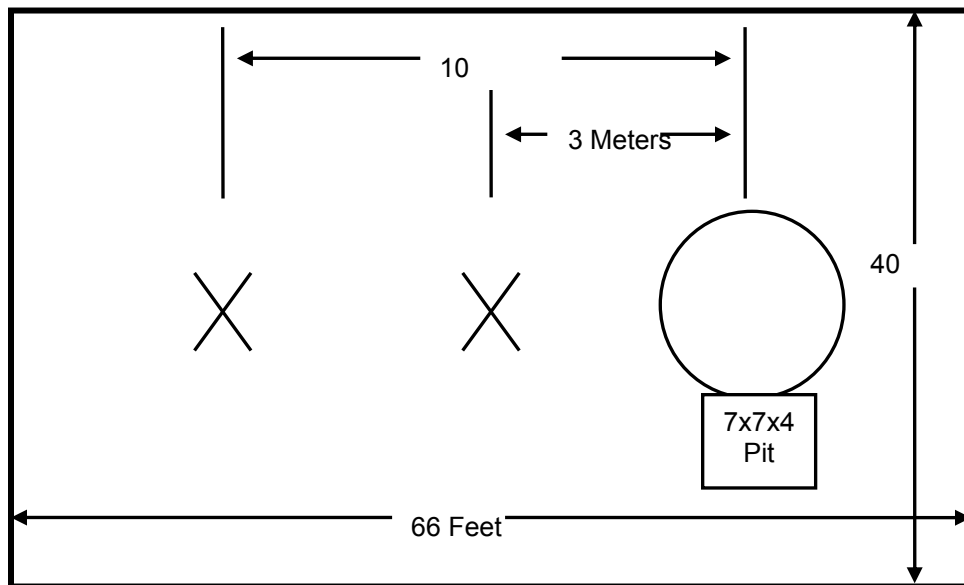

**Figure 2.3-2: Open Area Test Site**

## 2.4 Conducted Emissions Test Site Description

The AC mains conducted EMI site is located in the main EMC lab. It consists of an 8' x 8' solid aluminum horizontal group reference plane (GRP) bonded every 3" to an 8' X 8' vertical ground plane.

The site is of sufficient size to test table top and floor standing equipment in accordance with section 6.1.4 of ANSI C63.4.

A diagram of the room is shown below in figure 4.1.3-1:

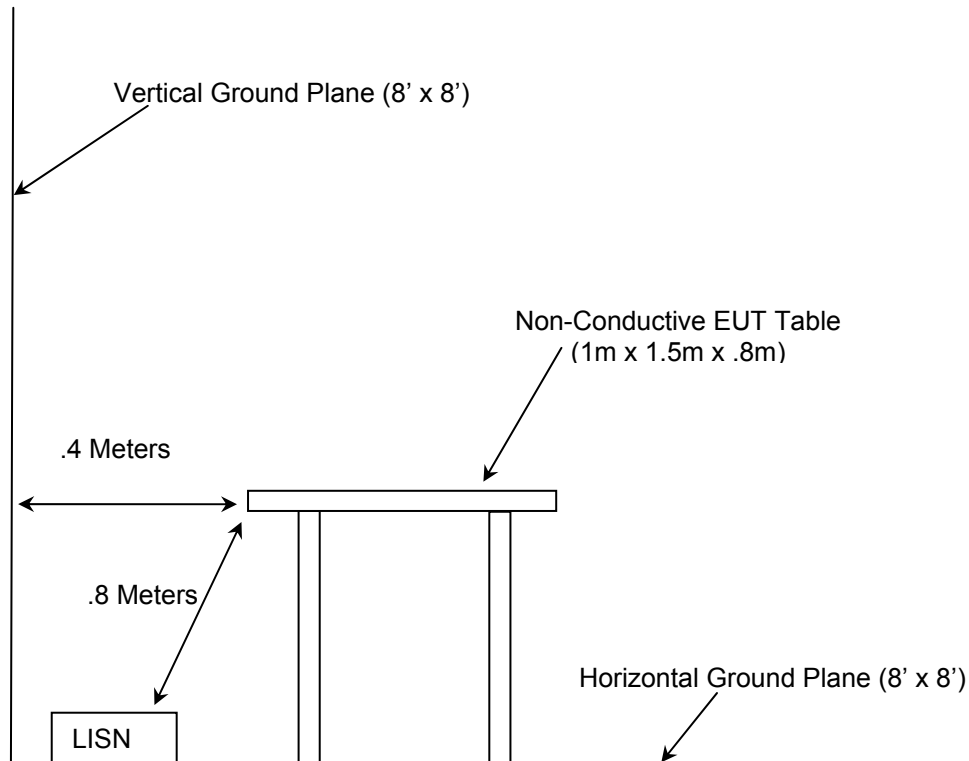

Figure 2.4-1: AC Mains Conducted EMI Site

## 3 APPLICABLE STANDARD REFERENCES

The following standards were used:

- ❖ ANSI C63.4-2003: Method of Measurements of Radio-Noise Emissions from Low-Voltage Electrical and Electronic Equipment in the 9KHz to 40GHz
- ❖ US Code of Federal Regulations (CFR): Title 47, Part 2, Subpart J: Equipment Authorization Procedures, 2010
- ❖ US Code of Federal Regulations (CFR): Title 47, Part 15, Subpart C: Radio Frequency Devices, Intentional Radiators, 2010
- ❖ Industry Canada Radio Standards Specification: RSS-210 - Low-power License-exempt Radiocommunication Devices (All Frequency Bands): Category I Equipment, Issue 8, Dec 2010
- ❖ Industry Canada Radio Standards Specification: RSS-Gen – General Requirements and Information for the Certification of Radiocommunication Equipment, Issue 3, Dec 2010.

#### 4 LIST OF TEST EQUIPMENT

The calibration interval of test equipment is annually or the manufacturer's recommendations. Where the calibration interval deviates from the annual cycle based on the instrument manufacturer's recommendations, it shall be stated below.

**Table 4-1: Test Equipment**

AssetID	Manufacturer	Model #	Equipment Type	Serial #	Last Calibration Date	Calibration Due Date
1	Rohde & Schwarz	ESMI - Display	Spectrum Analyzers	833771/007	9/23/2010	9/23/2012
2	Rohde & Schwarz	ESMI-Receiver	Spectrum Analyzers	839587/003	9/23/2010	9/23/2012
25	Chase	CBL6111	Antennas	1043	9/13/2010	9/13/2012
73	Agilent	8447D	Amplifiers	2727A05624	3/21/2011	3/21/2012
78	EMCO	6502	Antennas	9104-2608	1/31/2011	1/31/2013
152	EMCO	3825/2	LISN	9111-1905	11/2/2010	11/2/2012
153	EMCO	3825/2	LISN	9411-2268	1/13/2011	1/13/2012
167	ACS	Chamber EMI Cable Set	Cable Set	167	1/26/2011	1/26/2012
168	Hewlett Packard	11947A	Attenuators	44829	2/4/2011	2/4/2012
283	Rohde & Schwarz	FSP40	Spectrum Analyzers	1000033	8/31/2010	8/31/2011
324	ACS	Belden	Cables	8214	7/9/2010	7/9/2011
339	Aeroflex/Weinschel	AS-18	Attenuators	7142	7/1/2010	7/2/2011
426	Thermotron	S-8 Mini Max	Environmental Chamber	25-2888-10	8/30/2010	8/30/2011



5 SUPPORT EQUIPMENT

Table 5-1: Support Equipment

Item	Equipment Type	Manufacturer	Model Number	Serial Number
1	Power Supply	Phoenix Contact	Mini-PS-100-240AC/24DC/4	3030328159
2	Laptop	Dell	Latitude D600	CN-0D2125-48643-4CV-4032
3	Laptop Power Supply	Dell	PA-1650-05D	CN-05V092-71615-46A-2E27

6 EQUIPMENT UNDER TEST SETUP BLOCK DIAGRAM

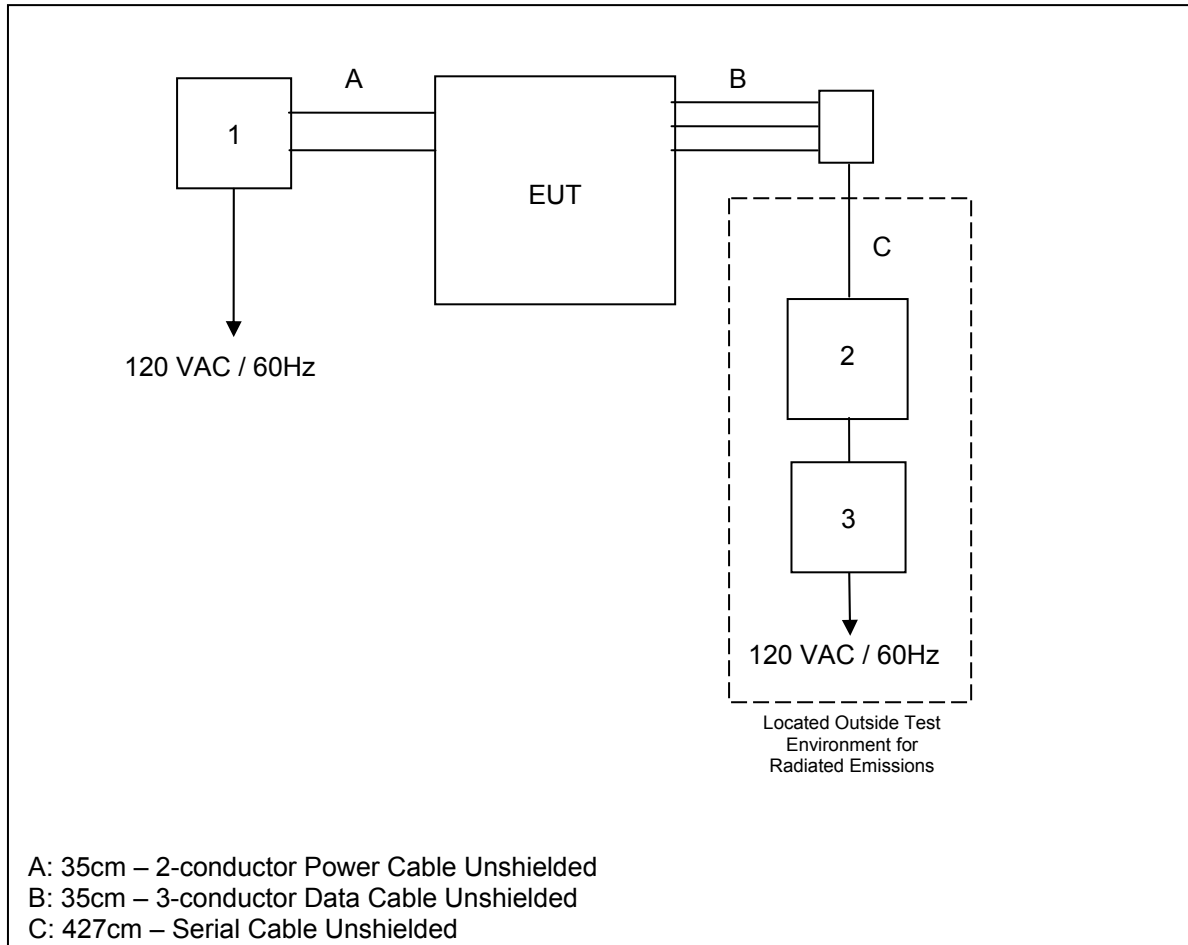

Figure 6-1: EUT Test Setup

## 7 SUMMARY OF TESTS

Along with the tabular data shown below, plots were taken of all signals deemed important enough to document.

### 7.1 Antenna Requirement – FCC: CFR 47 Part 15.203

The EUT utilizes an integral loop antenna which cannot be removed or modified without damaging or destroying the device therefore meeting the requirements of 15.203.

### 7.2 Power Line Conducted Emissions – FCC: CFR 47 Part 15.207/ IC RSS-Gen 7.2.4

#### 7.2.1 Measurement Procedure

ANSI C63.4 sections 6 and 7 were the guiding documents for this evaluation. Conducted emissions were performed from 150kHz to 30MHz with the spectrum analyzer's resolution bandwidth set to 9kHz and the video bandwidth set to 30kHz. The calculation for the conducted emissions is as follows:

$$\text{Corrected Reading} = \text{Analyzer Reading} + \text{LISN Loss} + \text{Cable Loss}$$

$$\text{Margin} = \text{Applicable Limit} - \text{Corrected Reading}$$

Measurements at the fundamental emission of 13.56MHz were made with the RF output loaded with a non-radiating load.

#### 7.2.2 Measurement Results

Results of the test are shown below in and Table 7.2.2-1 to 7.2.2.2.

**Table 7.2.2-1: Line 1 Conducted EMI Results**

Frequency (MHz)	Uncorrected Reading (dBuV)		Total Correction Factor (dB)	Corrected Level (dBuV)		Limit (dBuV)		Margin (dB)	
	Quasi-Peak	Average		Quasi-Peak	Average	Quasi-Peak	Average	Quasi-Peak	Average
0.164	33.44	21.99	10.09	43.53	32.08	65.26	55.26	21.7	23.2
0.205	28.76	18.79	10.02	38.78	28.81	63.41	53.41	24.6	24.6
0.246	25.76	18.29	10.02	35.78	28.31	61.89	51.89	26.1	23.6
0.501	24	22.23	10.00	34.00	32.23	55.98	45.98	22.0	13.8
2.362	18.47	14.52	10.11	28.58	24.63	56.00	46.00	27.4	21.4
13.56	19.52	18.51	10.44	29.96	28.95	60.00	50.00	30.0	21.1

Table 7.2.2-2: Line 2 Conducted EMI Results

Frequency (MHz)	Uncorrected Reading (dBuV)		Total Correction Factor (dB)	Corrected Level (dBuV)		Limit (dBuV)		Margin (dB)	
	Quasi-Peak	Average		Quasi-Peak	Average	Quasi-Peak	Average	Quasi-Peak	Average
0.165	32.8	21.26	10.09	42.89	31.35	65.21	55.21	22.3	23.9
0.205	28.25	17.63	10.02	38.27	27.65	63.41	53.41	25.1	25.8
0.247	24.97	16.33	10.02	34.99	26.35	61.86	51.86	26.9	25.5
0.497	21.51	18.09	10.00	31.51	28.09	56.05	46.05	24.5	18.0
2.75	14.48	10.95	10.11	24.59	21.06	56.00	46.00	31.4	24.9
13.56	17.74	16.48	10.44	28.18	26.92	60.00	50.00	31.8	23.1

7.3 Radiated Emissions – Intentional Radiation

7.3.1 In-Band Emissions Limitations – FCC Part 15.225(a),(b),(c) / IC RSS-210 A2.6

7.3.1.1 Test Methodology

Measurements below 30MHz were performed in a semi-anechoic chamber with a 3 meter separation distance between the EUT and measurement antenna. The EUT was rotated 360° and the loop antenna rotated about the vertical axis to maximize each emission. The magnetic loop receiving antenna was positioned with its center 1 meter above the ground.

The spectrum analyzer’s resolution and video bandwidths were set to 9 kHz and 30 kHz respectively. A peak detector was used which shows worst case. The measurements were corrected by a distance correction factor, antenna correction factors, and cable loss for comparison to the limits. Sample correction factors and calculations can be found section 7.3.2.2 and 7.3.2.4.

7.3.1.2 Test Results

Compliance with the emissions levels are shown in figure 7.3.1.2-1 below.

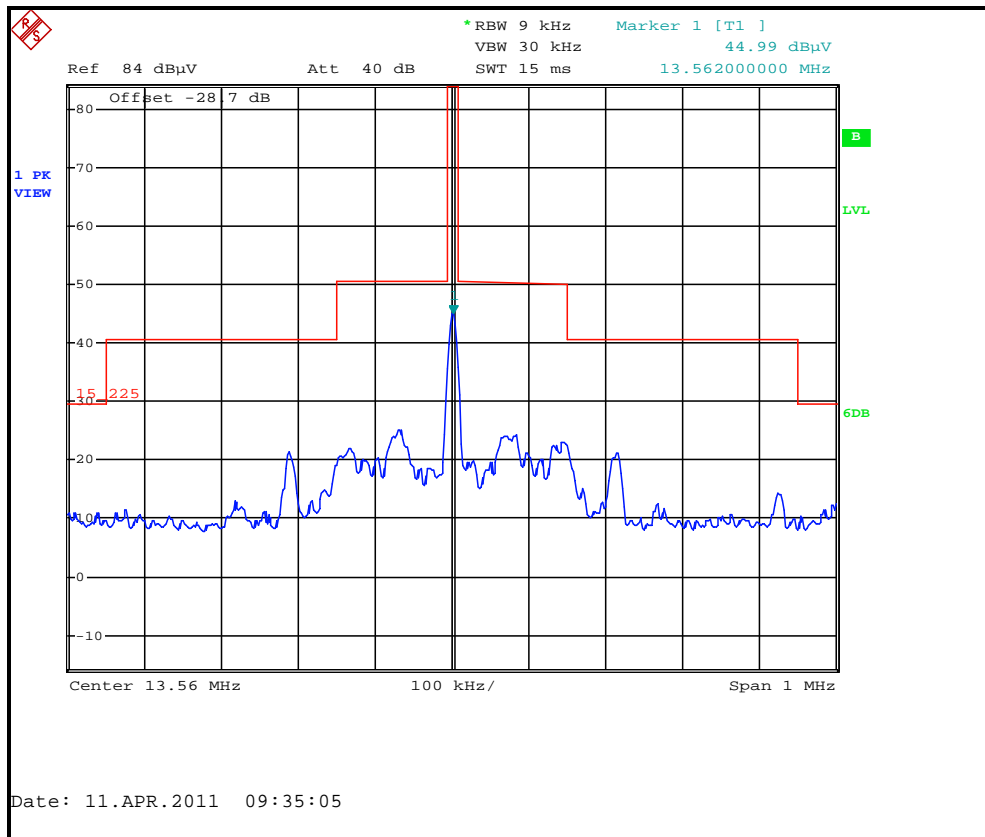

Figure 7.3.1.2-1: Emission Mask Plot

### 7.3.2 Out-of-Band Emissions – FCC Part 15.225(d) / IC RSS-Gen 7.2.5

#### 7.3.2.1 Test Methodology

Section 15.33(a)(4) specifies, if the intentional radiator contains a digital device, regardless of whether this digital device controls the functions of the intentional radiator or the digital device is used for additional control or function purposes other than to enable the operation of the intentional radiator, the frequency range shall be investigated up to frequency specified in 15.33(b)(1) for unintentional radiators. The upper frequency range for the digital device is 1000MHz which greater than the 10<sup>th</sup> harmonic of the fundamental frequency. The upper frequency range measured was 1000MHz.

Measurements below 30MHz were performed in a semi-anechoic chamber with a 3 meter separation distance between the EUT and measurement antenna. The EUT was rotated 360° and the loop antenna rotated about the vertical axis to maximize each emission. The magnetic receiving antenna was positioned with its center 1 meter above the ground.

For measurements in the frequency bands 9-90 kHz and 110-490 kHz, an average detector was used. When average measurements are specified, the peak emissions were also compared to a limit corresponding to 20 dB above the maximum permitted average limit according to Part 15.35. All other emissions were measured using a Quasi-peak detector. The final measurements were then corrected by a distance correction factor, antenna correction factors, and cable loss for comparison to the limits.

Measurements above 30MHz were performed in a semi-anechoic chamber with a 3 meter separation distance between the EUT and measurement antenna. The EUT was rotated through 360° and the receive antenna height was varied from 1m to 4m so that the maximum radiated emissions level would be detected. For frequencies below 1000MHz, quasi-peak measurements were made.

The spectrum analyzer's resolution bandwidth was set to equal to or greater than 100 Hz from 9 kHz to 150 kHz, 9 kHz from 150 kHz to 30 MHz, 120 kHz from 30 MHz to 1000 MHz, and 1 MHz from 1 GHz to 40 GHz.

For measurements for > 30MHz, the highest emissions with respect to the limit are reported.

#### 7.3.2.2 Distance Correction for Measurements Below 30 MHz – Part 15.31

Radiated measurements were performed at a distance closer than 30m as required according to Part 15.209. Therefore a correction factor was applied to account for propagation loss at the specified distance. The propagation loss was determined by using the square of an inverse linear distance extrapolation factor (40dB/decade) according to 15.31. A sample calculation of the distance correction factor is shown below for limits expressed at a 30m measurement distance.

$$\begin{aligned}\text{Distance correction factor (30m Specified Test Distance)} &= 40 \cdot \text{Log} (\text{Test Distance}/30) \\ &= 40 \cdot \text{Log} (3/30) \\ &= - 40 \text{ dB}\end{aligned}$$

7.3.2.3 Test Results

Radiated spurious emissions found are reported in Table 7.3.2.3-1.

Table 7.3.2.3-1: Radiated Spurious Emissions

Frequency (MHz)	Level (dBuV)		Antenna Polarity (H/V)	Correction Factors (dB)	Corrected Level (dBuV/m)		Limit (dBuV/m)		Margin (dB)	
	pk	Qpk/Avg			pk	Qpk/Avg	pk	Qpk/Avg	pk	Qpk/Avg
27.12	-----	13.94	-----	9.86	-----	23.80	-----	69.5	-----	45.7
40.69	-----	24.68	H	-12.33	-----	12.35	-----	40.0	-----	27.7
40.69	-----	42.12	V	-12.33	-----	29.79	-----	40.0	-----	10.2
78.5	-----	36.08	H	-18.18	-----	17.90	-----	40.0	-----	22.1
78.5	-----	52.53	V	-18.18	-----	34.35	-----	40.0	-----	5.7
90.35	-----	35.32	H	-16.25	-----	19.07	-----	43.5	-----	24.4
90.35	-----	48.80	V	-16.25	-----	32.55	-----	43.5	-----	11.0
109.21	-----	35.26	H	-13.95	-----	21.31	-----	43.5	-----	22.2
109.21	-----	38.87	V	-13.95	-----	24.92	-----	43.5	-----	18.6
203.38	-----	48.49	H	-15.30	-----	33.19	-----	43.5	-----	10.3
203.38	-----	42.93	V	-15.30	-----	27.63	-----	43.5	-----	15.9
230.5	-----	47.71	H	-13.94	-----	33.77	-----	46.0	-----	12.2
230.5	-----	48.22	V	-13.94	-----	34.28	-----	46.0	-----	11.7
258.49	-----	43.59	H	-10.95	-----	32.64	-----	46.0	-----	13.4
258.49	-----	46.51	V	-10.95	-----	35.56	-----	46.0	-----	10.4
311.87	-----	42.30	H	-10.91	-----	31.39	-----	46.0	-----	14.6
311.87	-----	35.67	V	-10.91	-----	24.76	-----	46.0	-----	21.2
380.28	-----	40.72	H	-8.20	-----	32.52	-----	46.0	-----	13.5
380.28	-----	36.18	V	-8.20	-----	27.98	-----	46.0	-----	18.0
406.79	-----	39.76	H	-7.26	-----	32.50	-----	46.0	-----	13.5
406.79	-----	34.2	V	-7.26	-----	26.94	-----	46.0	-----	19.1
433.91	-----	42.04	H	-6.49	-----	35.55	-----	46.0	-----	10.4
433.91	-----	38.54	V	-6.49	-----	32.05	-----	46.0	-----	13.9
461.03	-----	43.34	H	-6.47	-----	36.87	-----	46.0	-----	9.1
461.03	-----	38.46	V	-6.47	-----	31.99	-----	46.0	-----	14

7.3.2.4 Sample Calculation:

Example Calculation – Average/Quasi-Peak

Limit < 30MHz

Limit (dBuV/m) = 20\*log(30) - Distance Correction Factor (Section 7.3.2.2)

Limit (dBuV/m) = 29.5 + 40

Limit (dBuV/m) = 69.5

$$R_C = R_U + CF_T$$

Where:

- CF<sub>T</sub> = Total Correction Factor (AF+CA+AG)
- R<sub>U</sub> = Uncorrected Reading
- R<sub>C</sub> = Corrected Level
- AF = Antenna Factor
- CA = Cable Attenuation
- AG = Amplifier Gain

Corrected Level: 13.94 + 9.86 = 23.80dBuV

Margin: 69.5dBuV – 23.80dBuV = 45.7dB

7.4 Occupied Bandwidth – FCC Part 15.215(c) / IC RSS-Gen 4.6.1

7.4.1 Test Methodology

The RBW was to  $\geq 1\%$  of the estimated bandwidth. The trace was set to max hold with a peak detector active. The measurement function of the analyzer was utilized to determine the 99% occupied bandwidth.

7.4.2 Test Results

The results are shown in Figure 7.4.2-1 and 7.4.2-2.

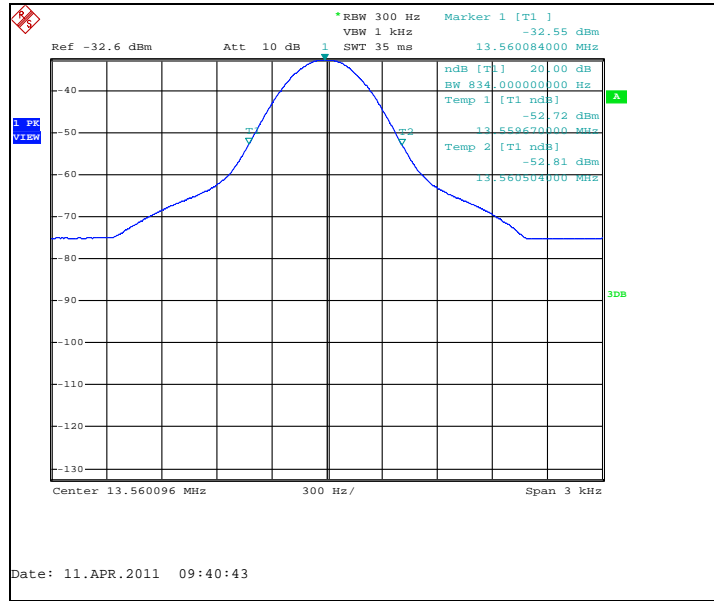

Figure 7.4.2-1: Occupied Bandwidth – 20dB

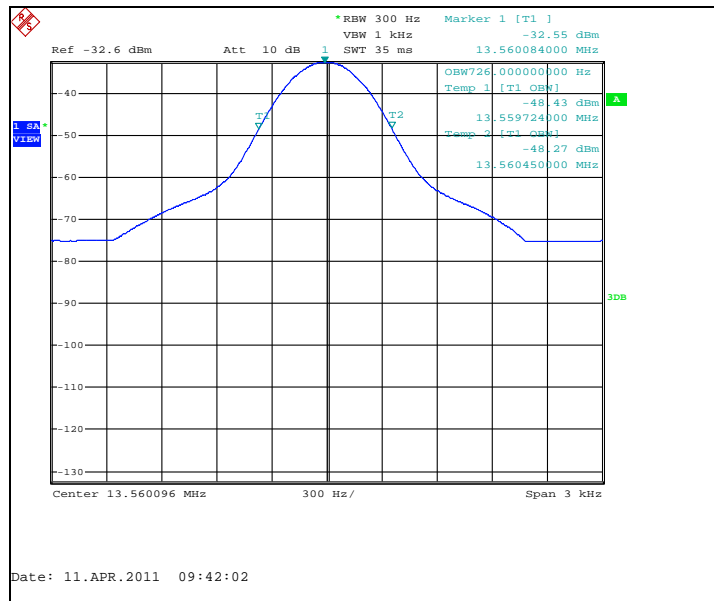

Figure 7.4.2-2: Occupied Bandwidth – 99%

**7.5 Frequency Stability – FCC CFR 47 Part 15.225(e) / IC RSS-210 A2.6**

**7.5.1 Test Methodology**

The equipment under test is placed inside an environmental chamber. The RF output is coupled to the input of the measurement equipment via a near field probe.

Frequency measurements were made at the extremes of the of temperature range -20° C to +50° C and at intervals of 10° C at normal supply voltage. A period of time sufficient to stabilize all components of the equipment was allowed at each frequency measurement. The maximum variation of frequency was recorded. The limit from rule part 15.225 is 0.01% or 100ppm.

**7.5.2 Test Results**

Results of the test are shown below in Figure 7.5.2-1.

<b>Frequency Stability</b>				
		<b>Frequency (MHz):</b>	13.56	
		<b>Deviation Limit (PPM):</b>	100ppm	
Temperature C	Frequency MHz	Frequency Error (PPM)	Voltage (%)	Voltage (VDC)
				24.00
-20 C	13.560097	7.153	100%	24.00
-10 C	13.560116	8.555	100%	24.00
0 C	13.560138	10.177	100%	24.00
10 C	13.560140	10.324	100%	24.00
20 C	13.560120	8.850	100%	24.00
30 C	13.560115	8.481	100%	24.00
40 C	13.560102	7.522	100%	24.00
50 C	13.560095	7.006	100%	24.00
20 C	13.560119	8.776	85%	20.40
20 C	13.560117	8.628	115%	27.60

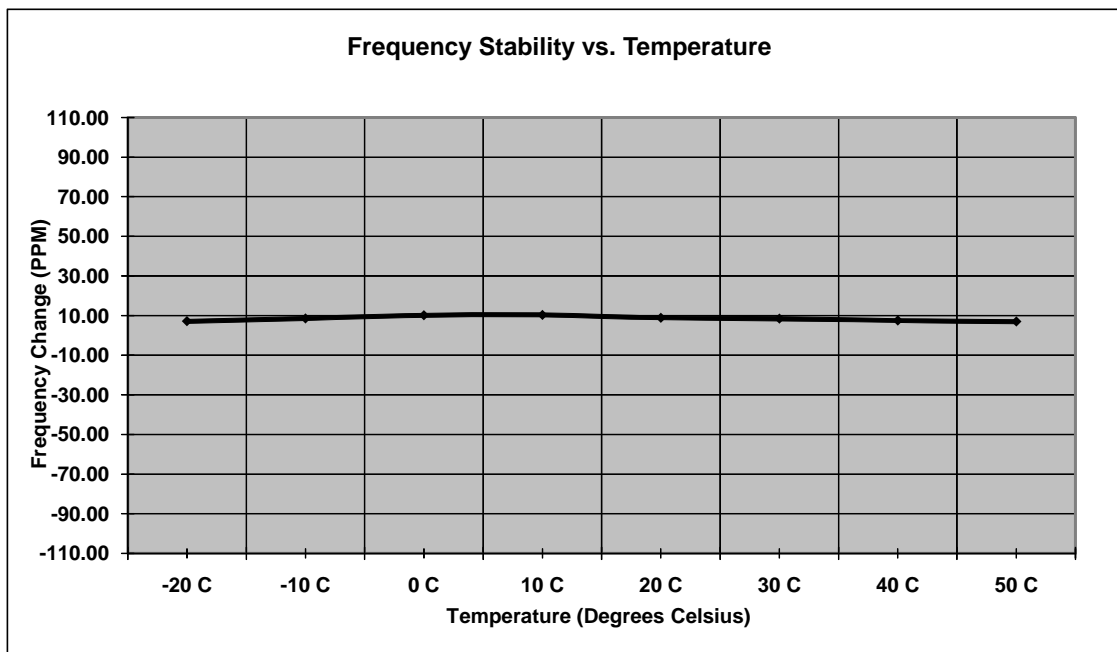

**Figure 7.5.2-1: Frequency Stability**



**8 CONCLUSION**

In the opinion of ACS, Inc. the FlexPay Contactless manufactured by Gilbarco, Inc. meets the requirements of FCC Part 15 subpart C and Industry Canada's Radio Standards Specification RSS-210.

**END REPORT**