



RADIO TEST REPORT

Test Report No. : 10156278H-A-R1

Applicant : silex technology, Inc.
Type of Equipment : SDIO Wireless Module
Model No. : SX-SDMGN
FCC ID : N6C-SDMGN
Test regulation : FCC Part 15 Subpart C: 2013
(Permissive Change Class II Application)
*Conducted emission and Radiated Spurious Emission
test only
Test Result : Complied

1. This test report shall not be reproduced in full or partial, without the written approval of UL Japan, Inc.
2. The results in this report apply only to the sample tested.
3. This sample tested is in compliance with the above regulation.
4. The test results in this report are traceable to the national or international standards.
5. This test report must not be used by the customer to claim product certification, approval, or endorsement by NVLAP, NIST, or any agency of the Federal Government.
6. This report is a revised version of 10156278H-A. 10156278H-A is replaced with this report.

Date of test: February 3 to 15, 2014

Representative test engineer:

Hironobu Ohnishi
Engineer of WiSE Japan,
UL Verification Service

Approved by:

Takahiro Hatakeda
Leader of WiSE Japan,
UL Verification Service



NVLAP LAB CODE: 200572-0

This laboratory is accredited by the NVLAP LAB CODE 200572-0, U.S.A. The tests reported herein have been performed in accordance with its terms of accreditation. *As for the range of Accreditation in NVLAP, you may refer to the WEB address, <http://www.ul.com/japan/jpn/pages/services/emc/about/mark1/index.jsp#nvlap>

UL Japan, Inc.

Head Office EMC Lab.

4383-326 Asama-cho, Ise-shi, Mie-ken 516-0021 JAPAN

Telephone : +81 596 24 8999

Facsimile : +81 596 24 8124

13-EM-F0429

CONTENTS	PAGE
SECTION 1: Customer information	4
SECTION 2: Equipment under test (E.U.T.)	4
SECTION 3: Test specification, procedures & results	5
SECTION 4: Operation of E.U.T. during testing	8
SECTION 5: Conducted Emission	10
SECTION 6: Radiated Spurious Emission	11
APPENDIX 1: Data of EMI test	12
Conducted Emission	12
Radiated Spurious Emission	14
APPENDIX 2: Test instruments	31
APPENDIX 3: Photographs of test setup	32
Conducted Emission	32
Radiated Spurious Emission	34
Worst Case Position	36

SECTION 1: Customer information

Company Name : silex technology, Inc.
Address : 2-3-1 Hikaridai, Seika-cho, Kyoto 619-0237, Japan
Telephone Number : +81-774-98-3878
Facsimile Number : +81-774-98-3758
Contact Person : Toshiro Kometani

SECTION 2: Equipment under test (E.U.T.)

2.1 Identification of E.U.T.

Type of Equipment : SDIO Wireless Module
Model No. : SX-SDMGN
Serial No. : Refer to Clause 4.2
Rating : DC3.3V
Receipt Date of Sample : December 19, 2013
Country of Mass-production : Japan
Condition of EUT : Production model
Modification of EUT : No Modification by the test lab

2.2 Product Description

Model No: SX-SDMGN (referred to as the EUT in this report) is the SDIO Wireless Module.

General Specification

Clock frequency(ies) in the system : 26MHz

Radio Specification

Radio Type : Transceiver
Method of Frequency Generation : Synthesizer
Power Supply (inner) : DC1.8V
Antenna Gain : 5dBi (Antenna 1, 2)
2.89dBi (Antenna 3)

	IEEE802.11b	IEEE802.11g	IEEE802.11n (20 M band)
Frequency of operation	2412-2462MHz	2412-2462MHz	2412 - 2462MHz
Type of modulation	DSSS (CCK, DQPSK, DBPSK)	OFDM-CCK (64QAM, 16QAM, QPSK, BPSK)	OFDM (64QAM, 16QAM, QPSK, BPSK)
Channel spacing	5MHz		5MHz
Antenna type	Omni-directional Pole Antenna (Antenna 1, 2) PCB Printed Antenna (Antenna 3)		
Antenna Connector type	R-SMA connector (Antenna 1, 2) U.FL Alternative connector (Antenna 3)		

<Contents of the change from original model>

Test Report Number of original model is 32IE0153-HO-01-A-R2.

Specification was changed from the original model as follows:

*Antenna of the EUT was modified. The radio specification is identical to the original.

Therefore only Conducted emission test and Radiated Spurious Emission test were performed in this report.

Additionally, only the information of modified antenna is described in this report.

UL Japan, Inc.

Head Office EMC Lab.

4383-326 Asama-cho, Ise-shi, Mie-ken 516-0021 JAPAN

Telephone : +81 596 24 8999

Facsimile : +81 596 24 8124

SECTION 3: Test specification, procedures & results

3.1 Test Specification

Test Specification : FCC Part 15 Subpart C: 2013, final revised on September 30, 2013 and effective October 30, 2013

Title : FCC 47CFR Part15 Radio Frequency Device Subpart C Intentional Radiators
Section 15.207 Conducted limits
Section 15.247 Operation within the bands 902-928MHz,
2400-2483.5MHz, and 5725-5850MHz

3.2 Procedures and results

Item	Test Procedure	Specification	Worst Margin	Results	Remarks
Conducted Emission	FCC: ANSI C63.4:2003 7. AC powerline Conducted Emission measurements IC: RSS-Gen 7.2.4	FCC: Section 15.207 ----- IC: RSS-Gen 7.2.4	QP 17.0dB, 28.89800MHz, L AV 12.2dB, 28.89800MHz, L	Complied	-
Spurious Emission & Band Edge Compliance	FCC: FCC Public Notice DA 00-705 IC: RSS-Gen 4.9	FCC: Section15.247(d) ----- IC: RSS-210 A8.5 RSS-Gen 6 and 7.2.3	3.1dB 2483.500MHz, AV, Hori.	Complied	Radiated

Note: UL Japan, Inc.'s EMI Work Procedures No. 13-EM-W0420 and 13-EM-W0422.

* In case any questions arise about test procedure, ANSI C63.4: 2003 is also referred.

FCC 15.31 (e)

The RF Module has own regulator.

The RF Module is constantly provided voltage through own regulator regardless of input voltage (DC3.3V).

Therefore, this EUT complies with the requirement.

FCC Part 15.203/212 Antenna requirement

The EUT has a unique antenna connector (U.FL on the Module).

Therefore the equipment complies with the requirement of 15.203/212.

UL Japan, Inc.

Head Office EMC Lab.

4383-326 Asama-cho, Ise-shi, Mie-ken 516-0021 JAPAN

Telephone : +81 596 24 8999

Facsimile : +81 596 24 8124

3.3 Addition to standard

No addition, exclusion nor deviation has been made from the standard.

3.4 Uncertainty

EMI

The following uncertainties have been calculated to provide a confidence level of 95% using a coverage factor k=2.

Test room (semi-anechoic chamber)	Conducted emission (+dB)
	150kHz-30MHz
No.1	3.5dB
No.2	3.5dB
No.3	3.6dB
No.4	3.5dB

Test room (semi-anechoic chamber)	Radiated emission						
	(3m*)(+dB)				(1m*)(+dB)		(0.5m*)(+dB)
	9kHz -30MHz	30MHz -300MHz	300MHz -1GHz	1GHz -10GHz	10GHz -18GHz	18GHz -26.5GHz	26.5GHz -40GHz
No.1	4.0dB	5.1dB	5.0dB	5.1dB	6.0dB	4.9dB	4.3dB
No.2	3.9dB	5.2dB	5.0dB	4.9dB	5.9dB	4.7dB	4.2dB
No.3	4.3dB	5.1dB	5.2dB	5.2dB	6.0dB	4.8dB	4.2dB
No.4	4.6dB	5.2dB	5.0dB	5.2dB	6.0dB	5.7dB	4.2dB

*3m/1m/0.5m = Measurement distance

Conducted Emission test

The data listed in this test report has enough margin, more than the site margin.

Radiated emission test(3m)

The data listed in this report meets the limits unless the uncertainty is taken into consideration.

UL Japan, Inc.

Head Office EMC Lab.

4383-326 Asama-cho, Ise-shi, Mie-ken 516-0021 JAPAN

Telephone : +81 596 24 8999

Facsimile : +81 596 24 8124

3.5 Test Location

UL Japan, Inc. Head Office EMC Lab. *NVLAP Lab. code: 200572-0
4383-326 Asama-cho, Ise-shi, Mie-ken 516-0021 JAPAN
Telephone : +81 596 24 8999 Facsimile : +81 596 24 8124

	FCC Registration Number	IC Registration Number	Width x Depth x Height (m)	Size of reference ground plane (m) / horizontal conducting plane	Other rooms
No.1 semi-anechoic chamber	313583	2973C-1	19.2 x 11.2 x 7.7m	7.0 x 6.0m	No.1 Power source room
No.2 semi-anechoic chamber	655103	2973C-2	7.5 x 5.8 x 5.2m	4.0 x 4.0m	-
No.3 semi-anechoic chamber	148738	2973C-3	12.0 x 8.5 x 5.9m	6.8 x 5.75m	No.3 Preparation room
No.3 shielded room	-	-	4.0 x 6.0 x 2.7m	N/A	-
No.4 semi-anechoic chamber	134570	2973C-4	12.0 x 8.5 x 5.9m	6.8 x 5.75m	No.4 Preparation room
No.4 shielded room	-	-	4.0 x 6.0 x 2.7m	N/A	-
No.5 semi-anechoic chamber	-	-	6.0 x 6.0 x 3.9m	6.0 x 6.0m	-
No.6 shielded room	-	-	4.0 x 4.5 x 2.7m	4.0 x 4.5 m	-
No.6 measurement room	-	-	4.75 x 5.4 x 3.0m	4.75 x 4.15 m	-
No.7 shielded room	-	-	4.7 x 7.5 x 2.7m	4.7 x 7.5m	-
No.8 measurement room	-	-	3.1 x 5.0 x 2.7m	N/A	-
No.9 measurement room	-	-	8.0 x 4.6 x 2.8m	2.4 x 2.4m	-
No.11 measurement room	-	-	6.2 x 4.7 x 3.0m	2.4 x 3.4m	-

* Size of vertical conducting plane (for Conducted Emission test) : 2.0 x 2.0m for No.1, No.2, No.3, and No.4 semi-anechoic chambers and No.3 and No.4 shielded rooms.

3.6 Data of EMI, Test instruments, and Test set up

Refer to APPENDIX.

UL Japan, Inc.

Head Office EMC Lab.

4383-326 Asama-cho, Ise-shi, Mie-ken 516-0021 JAPAN

Telephone : +81 596 24 8999

Facsimile : +81 596 24 8124

SECTION 4: Operation of E.U.T. during testing

4.1 Operating Mode(s)

Test operating mode was determined as follows according to “Section 1 of 6 802.11 a/b/g/n testing- Managing Complex Regulatory Approvals - ” of TCB Council Workshop October 2009.

*The worst test mode in original test report was used in this report.

Mode	Remarks*
IEEE 802.11b (11b)	11Mbps (Long GI), PN9
IEEE 802.11g (11g)	24Mbps (Long GI), PN9
IEEE 802.11n-20MHz BW (11n-20)	MCS 4 (Long GI), PN9
*Transmitting duty was close to 100% on all tests.	
*The worst condition was determined based on the test result of Maximum Peak Output Power (Mid Channel)	
*EUT has the power settings by the software as follows; Power settings: 11b 11Mbps(Long GI): 13.0 dBm 11g 24Mbps(Long GI): 2412MHz: 10.5 dBm, 2437MHz: 14.5 dBm, 2462MHz: 10.5 dBm 11n-20 MCS 4(Long GI): 2412MHz: 10.0 dBm, 2437MHz: 14.5 dBm, 2462MHz: 10.0 dBm Software: Atheros Test Command (Athtestcmd) v3.1.1 Build 563	
*Any conditions under the normal use do not exceed the condition of setting. In addition, end users cannot change the settings of the output power of the product.	

*The details of Operating mode(s)

Test Item	Operating Mode	Tested Antenna	Tested frequency
Conducted Emission	11g Tx *1)	CN1 *2)	2437MHz
Spurious Emission (Radiated)	11b Tx 11g Tx	CN1 *2)	2412MHz 2437MHz 2462MHz
	11n-20 Tx		CN1 *2)

*1) The mode was tested as a representative, because it had the highest power at antenna terminal test.

Please see test report No. 32IE0153-HO-01-A-R2 for Antenna terminal test result.

*2) After the comparison between CN1 and CN2, test was performed with the antenna that had higher power as a representative.

UL Japan, Inc.

Head Office EMC Lab.

4383-326 Asama-cho, Ise-shi, Mie-ken 516-0021 JAPAN

Telephone : +81 596 24 8999

Facsimile : +81 596 24 8124

4.2 Configuration and peripherals

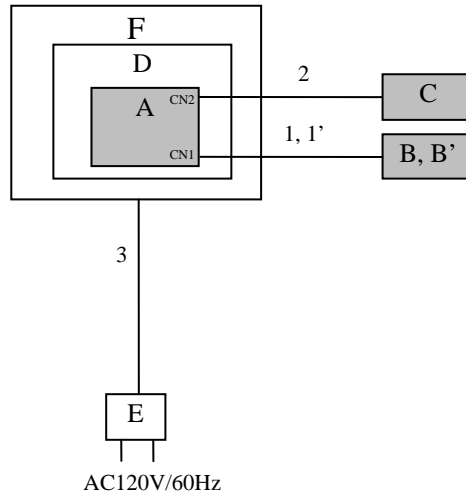

- * Cabling and setup were taken into consideration and test data was taken under worse case conditions.
- * EUT has two antenna ports. They do not transmit simultaneously.
- * The test was performed with only two combinations: Antenna 3 + Antenna 2 and Antenna 1 + Antenna 2.
- * Radiated emission was tested with the EUT on a single jig board in original application. For this testing, the antenna radiation was focused, and different jig boards were used.

Description of EUT and Support equipment

No.	Item	Model number	Serial number	Manufacturer	Remark
A	SDIO Wireless Module	SX-SDMGN	0080924DE386	silex technology, Inc.	EUT
B	Antenna 1	IAF-6550RS3X	001	Joymax Electronics Co., Ltd.	EUT
B'	Antenna 3	FMM2.4W45HA-U	001	NISSEI Limited	EUT
C	Antenna 2	IAF-6550RS3X	002	Joymax Electronics Co., Ltd.	EUT
D	Jig	-	-	silex technology, Inc.	-
E	AC Adaptor	US115-05	C08-0259307	UNIFIVE	-
F	Jig	-	-	silex technology, Inc.	-

List of cables used

No.	Name	Length (m)	Shield		Remark
			Cable	Connector	
1	Antenna 1 Cable	3.0	Shielded	Shielded	-
1'	Antenna 3 Cable	0.1	Shielded	Shielded	-
2	Antenna 2 Cable	3.0	Shielded	Shielded	-
3	DC Cable	1.8	Unshielded	Unshielded	-

UL Japan, Inc.

Head Office EMC Lab.

4383-326 Asama-cho, Ise-shi, Mie-ken 516-0021 JAPAN

Telephone : +81 596 24 8999

Facsimile : +81 596 24 8124

SECTION 5: Conducted Emission

Test Procedure and conditions

EUT was placed on a urethane platform of nominal size, 0.5m by 1.0m, raised 0.8m above the conducting ground plane.

The rear of tabletop was located 40cm to the vertical conducting plane. The rear of EUT, including peripherals aligned and flushed with rear of tabletop. All other surfaces of tabletop were at least 80cm from any other grounded conducting surface. EUT was located 80cm from a Line Impedance Stabilization Network (LISN)/ Artificial mains Network (AMN) and excess AC cable was bundled in center.

For the tests on EUT with other peripherals (as a whole system)

I/O cables that were connected to the peripherals were bundled in center. They were folded back and forth forming a bundle 30cm to 40cm long and were hanged at a 40cm height to the ground plane. All unused 50ohm connectors of the LISN(AMN) were resistivity terminated in 50ohm when not connected to the measuring equipment.

The AC Mains Terminal Continuous disturbance Voltage has been measured with the EUT in a Semi Anechoic Chamber.

The EUT was connected to a LISN (AMN).

An overview sweep with peak detection has been performed.

The test results and limit are rounded off to one decimal place, so some differences might be observed.

Detector : QP and CISPR AV
Measurement range : 0.15-30MHz
Test data : APPENDIX
Test result : Pass

UL Japan, Inc.

Head Office EMC Lab.

4383-326 Asama-cho, Ise-shi, Mie-ken 516-0021 JAPAN

Telephone : +81 596 24 8999

Facsimile : +81 596 24 8124

SECTION 6: Radiated Spurious Emission

Test Procedure

It was measured based on "11.0 Emissions in non-restricted frequency bands" of "Guidance for Performing Compliance Measurements on Digital Transmission Systems (DTS) Operating Under §15.247 (Issued on April 9, 2013)".

EUT was placed on a urethane platform of nominal size, 0.5m by 1.0m, raised 0.8m above the conducting ground plane.

The Radiated Electric Field Strength has been measured in a Semi Anechoic Chamber with a ground plane.

The height of the measuring antenna varied between 1 and 4m and EUT was rotated a full revolution in order to obtain the maximum value of the electric field strength.

The measurements were performed for both vertical and horizontal antenna polarization with the Test Receiver, or the Spectrum Analyzer.

The measurements were made with the following detector function of the test receiver and the Spectrum analyzer (in linear mode).

The test was made with the detector (RBW/VBW) in the following table.

When using Spectrum analyzer, the test was made with adjusting span to zero by using peak hold.

Test Antennas are used as below;

Frequency	30MHz to 300MHz	300MHz to 1GHz	Above 1GHz
Antenna Type	Biconical	Logperiodic	Horn

In any 100kHz bandwidth outside the restricted band in which the spread spectrum intentional radiator is operating, the radio frequency power that is produced by the intentional radiator confirmed 20dB below that in the 100kHz bandwidth within the band that contains the highest level of the desired power, based on a radiated measurement.

20dBc was applied to the frequency over the limit of FCC 15.209 / Table 5 of RSS-Gen 7.2.5(IC) and outside the restricted band of FCC15.205 / Table 3 of RSS-Gen 7.2.2 (IC).

Frequency	Below 1GHz	Above 1GHz		20dBc
Instrument used	Test Receiver	Spectrum Analyzer		Spectrum Analyzer
Detector	QP	PK	AV *1)	PK
IF Bandwidth	BW 120kHz(T/R)	RBW: 1MHz VBW: 3MHz	RBW: 1MHz VBW: 10Hz	RBW: 100kHz VBW: 300kHz (S/A)
Test Distance	3m	3m (below 10GHz), 1m *2) (above 10GHz)		3m (below 10GHz), 1m *2) (above 10GHz)

*1) Average Power Measurement was performed based on 12.2.7 of "Guidance for Performing Compliance Measurements on Digital Transmission Systems (DTS) Operating Under §15.247 (Issued on April 9, 2013)"

*2) Distance Factor: $20 \times \log(3.0\text{m}/1.0\text{m}) = 9.5\text{dB}$

- The carrier level and noise levels were confirmed at each position of X, Y and Z axes of EUT and antenna to see the position of maximum noise, and the test was made at the position that has the maximum noise.

The test results and limit are rounded off to one decimal place, so some differences might be observed.

Measurement range : 30M-26.5GHz
Test data : APPENDIX
Test result : Pass

UL Japan, Inc.

Head Office EMC Lab.

4383-326 Asama-cho, Ise-shi, Mie-ken 516-0021 JAPAN

Telephone : +81 596 24 8999

Facsimile : +81 596 24 8124

APPENDIX 1: Data of EMI test

Conducted Emission
(Antenna 1)

DATA OF CONDUCTED EMISSION TEST

UL Japan, Inc. Head Office EMC Lab. No.2 Semi Anechoic Chamber
Date : 2014/02/05

Report No. : 10156278H
 Temp./Humi. : 21deg. C / 30% RH
 Engineer : Tomohisa Nakagawa

Mode / Remarks : Tx 11g 2437MHz

LIMIT : FCC15.207 QP
 FCC15.207 AV

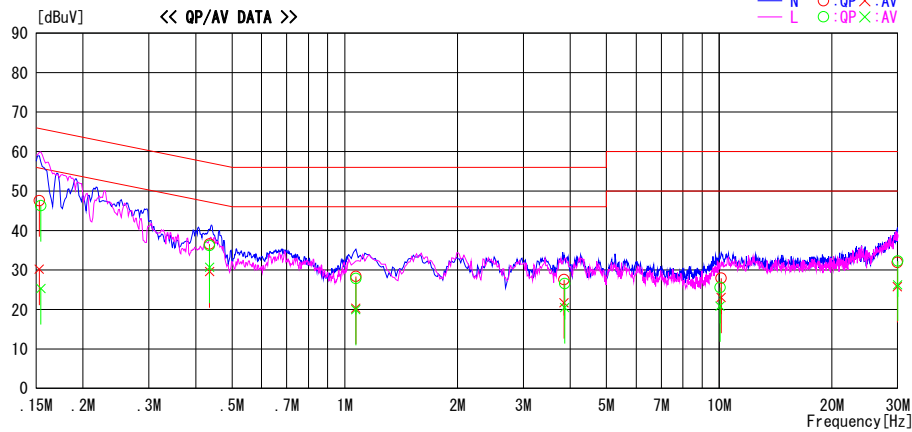

Frequency [MHz]	Reading Level		Corr. Factor [dB]	Results		Limit		Margin		Phase	Comment
	QP [dBuV]	AV [dBuV]		QP [dBuV]	AV [dBuV]	QP [dBuV]	AV [dBuV]	QP [dB]	AV [dB]		
0.15290	34.3	16.9	13.3	47.6	30.2	65.8	55.8	18.2	25.6	N	
0.43565	23.3	16.3	13.3	36.6	29.6	57.1	47.1	20.5	17.5	N	
1.07070	15.0	6.9	13.4	28.4	20.3	56.0	46.0	27.6	25.7	N	
3.85217	13.5	7.6	14.1	27.6	21.7	56.0	46.0	28.4	24.3	N	
10.11708	12.9	8.1	15.0	27.9	23.1	60.0	50.0	32.1	26.9	N	
29.89980	13.5	7.4	18.4	31.9	25.8	60.0	50.0	28.1	24.2	N	
0.15435	33.0	12.0	13.3	46.3	25.3	65.8	55.8	19.5	30.5	L	
0.43565	22.9	17.4	13.3	36.2	30.7	57.1	47.1	20.9	16.4	L	
1.07070	14.4	6.6	13.4	27.8	20.0	56.0	46.0	28.2	26.0	L	
3.86729	12.5	6.4	14.1	26.6	20.5	56.0	46.0	29.4	25.5	L	
10.05025	10.6	5.9	15.0	25.6	20.9	60.0	50.0	34.4	29.1	L	
29.96663	13.9	7.8	18.4	32.3	26.2	60.0	50.0	27.7	23.8	L	

CHART: WITH FACTOR, Peak hold data. CALCULATION: RESULT=READING+C.F (LISN LOSS + ATT LOSS + CABLE LOSS)
 Except for the above table : adequate margin data below the limits.

Conducted Emission (Antenna 3)

DATA OF CONDUCTED EMISSION TEST

UL Japan, Inc. Head Office EMC Lab. No.2 Semi Anechoic Chamber
 Date : 2014/02/15

Report No. : 10156278H

Temp./Humi. : 22deg. C / 28% RH
 Engineer : Hironobu Ohnishi

Mode / Remarks : Tx 11g 2437MHz

LIMIT : FCC15.207 QP
 FCC15.207 AV

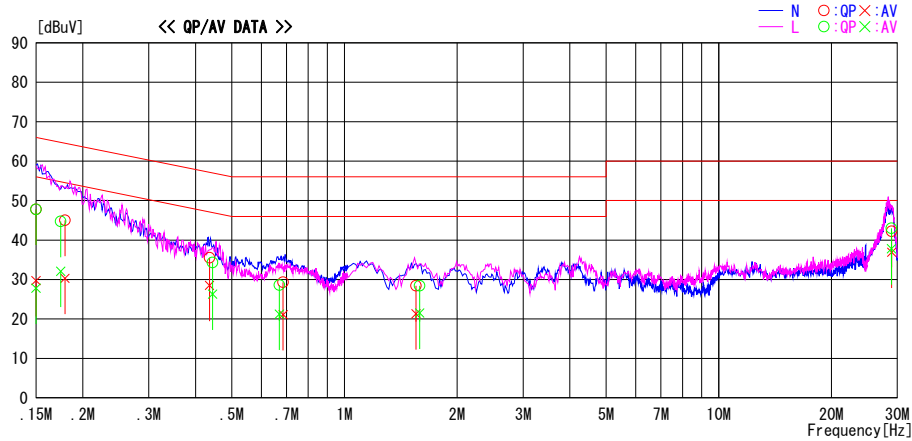

Frequency [MHz]	Reading Level		Corr. Factor [dB]	Results		Limit		Margin		Phase	Comment
	QP [dBuV]	AV [dBuV]		QP [dBuV]	AV [dBuV]	QP [dBuV]	AV [dBuV]	QP [dB]	AV [dB]		
0.15000	34.5	16.4	13.3	47.8	29.7	66.0	56.0	18.2	26.3	N	
0.17915	31.7	17.0	13.3	45.0	30.3	64.5	54.5	19.5	24.2	N	
0.43605	22.2	15.2	13.3	35.5	28.5	57.1	47.1	21.6	18.6	N	
0.68586	15.9	7.7	13.4	29.3	21.1	56.0	46.0	26.7	24.9	N	
1.55338	14.8	7.7	13.6	28.4	21.3	56.0	46.0	27.6	24.7	N	
28.96120	23.9	18.6	18.3	42.2	36.9	60.0	50.0	17.8	13.1	N	
0.15000	34.5	14.5	13.3	47.8	27.8	66.0	56.0	18.2	28.2	L	
0.17458	31.4	18.8	13.3	44.7	32.1	64.7	54.7	20.0	22.6	L	
0.44435	21.0	13.0	13.3	34.3	26.3	57.0	47.0	22.7	20.7	L	
0.67013	15.2	7.8	13.4	28.6	21.2	56.0	46.0	27.4	24.8	L	
1.58792	14.8	7.9	13.6	28.4	21.5	56.0	46.0	27.6	24.5	L	
28.89800	24.7	19.5	18.3	43.0	37.8	60.0	50.0	17.0	12.2	L	

CHART: WITH FACTOR, Peak hold data. CALCULATION: RESULT=READING+C.F (LISN LOSS+ATTEN. LOSS+CABLE LOSS)
 Except for the above table : adequate margin data below the limits.

Radiated Spurious Emission

Test place	Head Office EMC Lab. No.3 Semi Anechoic Chamber	
Report No.	10156278H	
Date	02/03/2014	02/04/2014
Temperature/ Humidity	22 deg. C / 30% RH	21 deg. C / 30% RH
Engineer	Tomohisa Nakagawa	Tomohisa Nakagawa
	(1-10GHz)	(10-26.5GHz)
Mode	11b Tx 2437MHz, Antenna 1	

Polarity	Frequency [MHz]	Detector	Reading [dBuV]	Ant.Fac. [dB/m]	Loss [dB]	Gain [dB]	Result [dBuV/m]	Limit [dBuV/m]	Margin [dB]	Remark
Hori	3249.317	PK	44.6	29.1	3.7	32.0	45.4	73.9	28.5	
Hori	4874.000	PK	41.2	30.6	5.3	31.4	45.7	73.9	28.2	
Hori	7311.000	PK	41.9	35.9	5.9	32.4	51.3	73.9	22.6	
Hori	9748.000	PK	41.7	39.4	7.3	33.0	55.4	73.9	18.5	
Hori	3249.317	AV	36.0	29.1	3.7	32.0	36.8	53.9	17.1	
Hori	4874.000	AV	28.0	30.6	5.3	31.4	32.5	53.9	21.4	
Hori	7311.000	AV	29.4	35.9	6.8	32.4	39.7	53.9	14.2	
Hori	9748.000	AV	29.1	39.4	7.3	33.0	42.8	53.9	11.1	
Vert	3249.317	PK	47.4	29.1	3.7	32.0	48.2	73.9	25.7	
Vert	4874.000	PK	41.0	30.6	5.3	31.4	45.5	73.9	28.4	
Vert	7311.000	PK	41.8	35.9	6.8	32.4	52.1	73.9	21.8	
Vert	9748.000	PK	42.5	39.4	7.3	33.0	56.2	73.9	17.7	
Vert	3249.317	AV	42.2	29.1	3.7	32.0	43.0	53.9	10.9	
Vert	4874.000	AV	28.1	30.6	5.3	31.4	32.6	53.9	21.3	
Vert	7311.000	AV	29.4	35.9	6.8	32.4	39.7	53.9	14.2	
Vert	9748.000	AV	29.1	39.4	7.3	33.0	42.8	53.9	11.1	

Result = Reading + Ant Factor + Loss (Cable+Attenuator+Filter-Distance factor(above 10GHz)) - Gain(Amplifier)

*Other frequency noises omitted in this report were not seen or had enough margin (more than 20dB).

*The 10th harmonic was not seen so the result was its base noise level.

Distance factor: 10GHz-26.5GHz 20log(3.0m/1.0m)= 9.5dB
 26.5GHz-40GHz 20log(3.0m/0.5m)=15.6dB

Radiated Spurious Emission

Test place Head Office EMC Lab. No.3 Semi Anechoic Chamber
Report No. 10156278H
Date 02/03/2014 02/04/2014
Temperature/ Humidity 22 deg. C / 30% RH 21 deg. C / 30% RH
Engineer Tomohisa Nakagawa Tomohisa Nakagawa
(1-10GHz) (10-26.5GHz)
Mode 11b Tx 2462MHz, Antenna 1

Polarity	Frequency [MHz]	Detector	Reading [dBuV]	Ant.Fac. [dB/m]	Loss [dB]	Gain [dB]	Result [dBuV/m]	Limit [dBuV/m]	Margin [dB]	Remark
Hori	2483.500	PK	50.2	28.4	3.1	32.3	49.4	73.9	24.5	
Hori	3282.742	PK	45.1	29.1	3.7	31.9	46.0	73.9	27.9	
Hori	4924.000	PK	40.6	30.7	5.3	31.4	45.2	73.9	28.7	
Hori	7386.000	PK	42.0	36.1	6.7	32.4	52.4	73.9	21.5	
Hori	9848.000	PK	42.0	39.6	7.4	33.1	55.9	73.9	18.0	
Hori	2483.500	AV	39.1	28.4	3.1	32.3	38.3	53.9	15.6	
Hori	3282.742	AV	35.8	29.1	3.7	31.9	36.7	53.9	17.2	
Hori	4924.000	AV	27.6	30.7	5.3	31.4	32.2	53.9	21.7	
Hori	7386.000	AV	29.4	36.1	6.7	32.4	39.8	53.9	14.1	
Hori	9848.000	AV	29.2	39.6	7.4	33.1	43.1	53.9	10.8	
Vert	2483.500	PK	50.0	28.4	3.1	32.3	49.2	73.9	24.7	
Vert	3282.742	PK	47.8	29.1	3.7	31.9	48.7	73.9	25.2	
Vert	4924.000	PK	39.7	30.7	5.3	31.4	44.3	73.9	29.6	
Vert	7386.000	PK	41.7	36.1	6.7	32.4	52.1	73.9	21.8	
Vert	9848.000	PK	41.8	39.6	7.4	33.1	55.7	73.9	18.3	
Vert	2483.500	AV	38.7	28.4	3.1	32.3	37.9	53.9	16.0	
Vert	3282.742	AV	42.9	29.1	3.7	31.9	43.8	53.9	10.1	
Vert	4924.000	AV	27.7	30.7	5.3	31.4	32.3	53.9	21.6	
Vert	7386.000	AV	29.4	36.1	6.7	32.4	39.8	53.9	14.1	
Vert	9848.000	AV	29.2	39.6	7.4	33.1	43.1	53.9	10.8	

Result = Reading + Ant Factor + Loss (Cable+Attenuator+Filter-Distance factor(above 10GHz)) - Gain(Amplifier)

*Other frequency noises omitted in this report were not seen or had enough margin (more than 20dB).

*The 10th harmonic was not seen so the result was its base noise level.

Distance factor: 10GHz-26.5GHz 20log(3.0m/1.0m)= 9.5dB
26.5GHz-40GHz 20log(3.0m/0.5m)=15.6dB

UL Japan, Inc.

Head Office EMC Lab.

4383-326 Asama-cho, Ise-shi, Mie-ken 516-0021 JAPAN

Telephone : +81 596 24 8999

Facsimile : +81 596 24 8124

Radiated Spurious Emission

Test place Head Office EMC Lab. No.3 Semi Anechoic Chamber
Report No. 10156278H
Date 02/03/2014 02/04/2014
Temperature/ Humidity 22 deg. C / 30% RH 21 deg. C / 30% RH
Engineer Tomohisa Nakagawa Tomohisa Nakagawa
(1-10GHz) (10-26.5GHz)
Mode 11g Tx 2412MHz, Antenna 1

Polarity	Frequency [MHz]	Detector	Reading [dBuV]	Ant.Fac. [dB/m]	Loss [dB]	Gain [dB]	Result [dBuV/m]	Limit [dBuV/m]	Margin [dB]	Remark
Hori	2390.000	PK	63.5	28.2	3.1	32.4	62.4	73.9	11.6	
Hori	3215.980	PK	44.7	29.1	3.6	32.0	45.4	73.9	28.5	
Hori	4824.000	PK	41.2	30.5	5.3	31.4	45.6	73.9	28.3	
Hori	7236.000	PK	41.5	35.8	6.7	32.3	51.7	73.9	22.2	
Hori	9648.000	PK	41.7	39.1	7.3	33.0	55.1	73.9	18.8	
Hori	2390.000	AV	47.9	28.2	3.1	32.4	46.8	53.9	7.1	
Hori	3215.980	AV	34.9	29.1	3.6	32.0	35.6	53.9	18.3	
Hori	4824.000	AV	27.9	30.5	5.3	31.4	32.3	53.9	21.6	
Hori	7236.000	AV	29.2	35.8	6.7	32.3	39.4	53.9	14.5	
Hori	9648.000	AV	29.2	39.1	7.3	33.0	42.6	53.9	11.3	
Vert	2390.000	PK	62.0	28.2	3.1	32.4	60.9	73.9	13.0	
Vert	3215.980	PK	48.1	29.1	3.6	32.0	48.8	73.9	25.1	
Vert	4824.000	PK	41.3	30.5	5.3	31.4	45.7	73.9	28.2	
Vert	7236.000	PK	42.3	35.8	6.7	32.3	52.5	73.9	21.4	
Vert	9648.000	PK	41.8	39.1	7.3	33.0	55.2	73.9	18.7	
Vert	2390.000	AV	48.0	28.2	3.1	32.4	46.9	53.9	7.0	
Vert	3215.980	AV	43.2	29.1	3.6	32.0	43.9	53.9	10.0	
Vert	4824.000	AV	28.2	30.5	5.3	31.4	32.6	53.9	21.3	
Vert	7236.000	AV	29.2	35.8	6.7	32.3	39.4	53.9	14.5	
Vert	9648.000	AV	29.2	39.1	7.3	33.0	42.6	53.9	11.3	

Result = Reading + Ant Factor + Loss (Cable+Attenuator+Filter-Distance factor(above 10GHz)) - Gain(Amplifier)

*Other frequency noises omitted in this report were not seen or had enough margin (more than 20dB).

*The 10th harmonic was not seen so the result was its base noise level.

Distance factor: 10GHz-26.5GHz 20log(3.0m/1.0m)= 9.5dB
26.5GHz-40GHz 20log(3.0m/0.5m)=15.6dB

20dBc Data Sheet

Polarity	Frequency [MHz]	Detector	Reading [dBuV]	Ant Factor [dB/m]	Loss [dB]	Gain [dB]	Result [dBuV/m]	Limit [dBuV/m]	Margin [dB]	Remark
Hori	2412.000	PK	98.3	28.2	3.1	32.4	97.2	-	-	Carrier
Hori	2400.000	PK	66.5	28.2	3.1	32.4	65.4	77.2	11.8	
Vert	2412.000	PK	96.9	28.2	3.1	32.4	95.8	-	-	Carrier
Vert	2400.000	PK	64.6	28.2	3.1	32.4	63.5	75.8	12.3	

Result = Reading + Ant Factor + Loss (Cable+Attenuator+Filter-Distance factor(above 10GHz)) - Gain(Amplifier)

UL Japan, Inc.

Head Office EMC Lab.

4383-326 Asama-cho, Ise-shi, Mie-ken 516-0021 JAPAN

Telephone : +81 596 24 8999

Facsimile : +81 596 24 8124

Radiated Spurious Emission

Test place Head Office EMC Lab. No.3 and No 2 Semi Anechoic Chamber
Report No. 10156278H
Date 02/03/2014 02/04/2014
Temperature/ Humidity 22 deg. C / 30% RH 21 deg. C / 30% RH
Engineer Tomohisa Nakagawa Tomohisa Nakagawa
(1-10GHz) (30-1000MHz),
(10-26.5GHz)
Mode 11g Tx 2437MHz, Antenna 1

Polarity	Frequency [MHz]	Detector	Reading [dBuV]	Ant.Fac. [dB/m]	Loss [dB]	Gain [dB]	Result [dBuV/m]	Limit [dBuV/m]	Margin [dB]	Remark
Hori	120.000	QP	23.0	12.9	7.6	28.4	15.1	43.5	28.4	
Hori	125.000	QP	23.0	13.3	7.7	28.3	15.7	43.5	27.8	
Hori	250.000	QP	23.5	17.1	8.5	27.7	21.4	46.0	24.6	
Hori	411.999	QP	29.6	17.4	9.4	28.4	28.0	46.0	18.0	
Hori	499.498	QP	29.0	18.1	9.8	28.8	28.1	46.0	17.9	
Hori	818.004	QP	23.6	21.8	10.9	28.1	28.2	46.0	17.8	
Hori	3249.317	PK	45.0	29.1	3.7	32.0	45.8	73.9	28.1	
Hori	4874.000	PK	41.2	30.6	5.3	31.4	45.7	73.9	28.2	
Hori	7311.000	PK	42.4	35.9	6.8	32.4	52.7	73.9	21.2	
Hori	9748.000	PK	42.2	39.4	7.3	33.0	55.9	73.9	18.0	
Hori	3249.317	AV	37.4	29.1	3.7	32.0	38.2	53.9	15.7	
Hori	4874.000	AV	28.2	30.6	5.3	31.4	32.7	53.9	21.2	
Hori	7311.000	AV	29.5	35.9	6.8	32.4	39.8	53.9	14.2	
Hori	9748.000	AV	29.0	39.4	7.3	33.0	42.7	53.9	11.2	
Vert	120.000	QP	23.0	12.9	7.6	28.4	15.1	43.5	28.4	
Vert	125.000	QP	23.0	13.3	7.7	28.3	15.7	43.5	27.8	
Vert	250.000	QP	23.5	17.1	8.5	27.7	21.4	46.0	24.6	
Vert	411.999	QP	28.9	17.4	9.4	28.4	27.3	46.0	18.7	
Vert	499.498	QP	22.3	18.1	9.8	28.8	21.4	46.0	24.6	
Vert	818.004	QP	30.2	21.8	10.9	28.1	34.8	46.0	11.2	
Vert	3249.317	PK	48.3	29.1	3.7	32.0	49.1	73.9	24.8	
Vert	4874.000	PK	41.0	30.6	5.3	31.4	45.5	73.9	28.4	
Vert	7311.000	PK	42.2	35.9	6.8	32.4	52.5	73.9	21.4	
Vert	9748.000	PK	41.5	39.4	7.3	33.0	55.2	73.9	18.7	
Vert	3249.317	AV	45.0	29.1	3.7	32.0	45.8	53.9	8.1	
Vert	4874.000	AV	28.3	30.6	5.3	31.4	32.8	53.9	21.1	
Vert	7311.000	AV	29.4	35.9	6.8	32.4	39.7	53.9	14.2	
Vert	9748.000	AV	29.0	39.4	7.3	33.0	42.7	53.9	11.2	

Result = Reading + Ant Factor + Loss (Cable+Attenuator+Filter-Distance factor(above 10GHz)) - Gain(Amplifier)

*Other frequency noises omitted in this report were not seen or had enough margin (more than 20dB).

*The 10th harmonic was not seen so the result was its base noise level.

Distance factor: 10GHz-26.5GHz 20log(3.0m/1.0m)= 9.5dB
26.5GHz-40GHz 20log(3.0m/0.5m)=15.6dB

UL Japan, Inc.

Head Office EMC Lab.

4383-326 Asama-cho, Ise-shi, Mie-ken 516-0021 JAPAN

Telephone : +81 596 24 8999

Facsimile : +81 596 24 8124

Radiated Spurious Emission

Test place Head Office EMC Lab. No.3 Semi Anechoic Chamber
Report No. 10156278H
Date 02/03/2014 02/04/2014
Temperature/ Humidity 22 deg. C / 30% RH 21 deg. C / 30% RH
Engineer Tomohisa Nakagawa Tomohisa Nakagawa
(1-10GHz) (10-26.5GHz)
Mode 11g Tx 2462MHz, Antenna 1

Polarity	Frequency [MHz]	Detector	Reading [dBuV]	Ant.Fac. [dB/m]	Loss [dB]	Gain [dB]	Result [dBuV/m]	Limit [dBuV/m]	Margin [dB]	Remark
Hori	2483.500	PK	66.2	28.4	3.1	32.3	65.4	73.9	8.5	
Hori	3282.742	PK	44.7	29.1	3.7	31.9	45.6	73.9	28.3	
Hori	4924.000	PK	40.2	30.7	5.3	31.4	44.8	73.9	29.1	
Hori	7386.000	PK	42.4	36.1	6.7	32.4	52.8	73.9	21.1	
Hori	9848.000	PK	42.2	39.6	7.4	33.1	56.1	73.9	17.8	
Hori	2483.500	AV	50.5	28.4	3.1	32.3	49.7	53.9	4.3	
Hori	3282.742	AV	36.0	29.1	3.7	31.9	36.9	53.9	17.0	
Hori	4924.000	AV	27.9	30.7	5.3	31.4	32.5	53.9	21.4	
Hori	7386.000	AV	29.5	36.1	6.7	32.4	39.9	53.9	14.0	
Hori	9848.000	AV	29.2	39.6	7.4	33.1	43.1	53.9	10.8	
Vert	2483.500	PK	64.0	28.4	3.1	32.3	63.2	73.9	10.7	
Vert	3282.742	PK	46.7	29.1	3.7	31.9	47.6	73.9	26.3	
Vert	4924.000	PK	40.9	30.7	5.3	31.4	45.5	73.9	28.4	
Vert	7386.000	PK	42.4	36.1	6.7	32.4	52.8	73.9	21.2	
Vert	9848.000	PK	41.8	39.6	7.4	33.1	55.7	73.9	18.2	
Vert	2483.500	AV	48.1	28.4	3.1	32.3	47.3	53.9	6.7	
Vert	3282.742	AV	39.7	29.1	3.7	31.9	40.6	53.9	13.3	
Vert	4924.000	AV	28.2	30.7	5.3	31.4	32.8	53.9	21.2	
Vert	7386.000	AV	29.4	36.1	6.7	32.4	39.8	53.9	14.1	
Vert	9848.000	AV	29.3	39.6	7.4	33.1	43.2	53.9	10.7	

Result = Reading + Ant Factor + Loss (Cable+Attenuator+Filter-Distance factor(above 10GHz)) - Gain(Amplifier)

*Other frequency noises omitted in this report were not seen or had enough margin (more than 20dB).

*The 10th harmonic was not seen so the result was its base noise level.

Distance factor: 10GHz-26.5GHz 20log(3.0m/1.0m)= 9.5dB
26.5GHz-40GHz 20log(3.0m/0.5m)=15.6dB

UL Japan, Inc.

Head Office EMC Lab.

4383-326 Asama-cho, Ise-shi, Mie-ken 516-0021 JAPAN

Telephone : +81 596 24 8999

Facsimile : +81 596 24 8124

Radiated Spurious Emission

Test place : Head Office EMC Lab. No.3 Semi Anechoic Chamber
 Report No. : 10156278H
 Date : 02/03/2014
 Temperature/ Humidity : 22 deg. C / 30% RH
 Engineer : Tomohisa Nakagawa
 Mode : 11n-20 Tx 2412MHz (Band edge only), Antenna 1

Polarity	Frequency [MHz]	Detector	Reading [dBuV]	Ant.Fac. [dB/m]	Loss [dB]	Gain [dB]	Result [dBuV/m]	Limit [dBuV/m]	Margin [dB]	Remark
Hori	2390.000	PK	65.9	28.2	3.1	32.4	64.8	73.9	9.1	
Hori	2390.000	AV	51.1	28.2	3.1	32.4	50.0	53.9	3.9	
Vert	2390.000	PK	64.0	28.2	3.1	32.4	62.9	73.9	11.0	
Vert	2390.000	AV	49.1	28.2	3.1	32.4	48.0	53.9	5.9	

Result = Reading + Ant Factor + Loss (Cable+Attenuator+Filter-Distance factor(above 10GHz)) - Gain(Amplifier)

*Other frequency noises omitted in this report were not seen or had enough margin (more than 20dB).

Distance factor: 10GHz-26.5GHz 20log(3.0m/1.0m)= 9.5dB
 26.5GHz-40GHz 20log(3.0m/0.5m)=15.6dB

20dBc Data Sheet

Polarity	Frequency [MHz]	Detector	Reading [dBuV]	Ant Factor [dB/m]	Loss [dB]	Gain [dB]	Result [dBuV/m]	Limit [dBuV/m]	Margin [dB]	Remark
Hori	2412.000	PK	99.0	28.2	3.1	32.4	97.9	-	-	Carrier
Hori	2400.000	PK	68.2	28.2	3.1	32.4	67.1	77.9	10.8	
Vert	2412.000	PK	97.5	28.2	3.1	32.4	96.4	-	-	Carrier
Vert	2400.000	PK	67.1	28.2	3.1	32.4	66.0	76.4	10.4	

Result = Reading + Ant Factor + Loss (Cable+Attenuator+Filter-Distance factor(above 10GHz)) - Gain(Amplifier)

UL Japan, Inc.

Head Office EMC Lab.

4383-326 Asama-cho, Ise-shi, Mie-ken 516-0021 JAPAN

Telephone : +81 596 24 8999

Facsimile : +81 596 24 8124

Radiated Spurious Emission

Test place Head Office EMC Lab. No.3 Semi Anechoic Chamber
Report No. 10156278H
Date 02/03/2014
Temperature/ Humidity 22 deg. C / 30% RH
Engineer Tomohisa Nakagawa
Mode 11n-20 Tx 2462MHz (Band edge only), Antenna 1

Polarity	Frequency [MHz]	Detector	Reading [dBuV]	Ant.Fac. [dB/m]	Loss [dB]	Gain [dB]	Result [dBuV/m]	Limit [dBuV/m]	Margin [dB]	Remark
Hori	2483.500	PK	66.5	28.4	3.1	32.3	65.6	73.9	8.3	
Hori	2483.500	AV	51.4	28.4	3.1	32.3	50.6	53.9	3.3	
Vert	2483.500	PK	65.1	28.4	3.1	32.3	64.3	73.9	9.6	
Vert	2483.500	AV	50.3	28.4	3.1	32.3	49.5	53.9	4.4	

Result = Reading + Ant Factor + Loss (Cable+Attenuator+Filter-Distance factor(above 10GHz)) - Gain(Amplifier)

*Other frequency noises omitted in this report were not seen or had enough margin (more than 20dB).

Distance factor: 10GHz-26.5GHz 20log(3.0m/1.0m)= 9.5dB
26.5GHz-40GHz 20log(3.0m/0.5m)=15.6dB

UL Japan, Inc.

Head Office EMC Lab.

4383-326 Asama-cho, Ise-shi, Mie-ken 516-0021 JAPAN

Telephone : +81 596 24 8999

Facsimile : +81 596 24 8124

Radiated Spurious Emission

Test place : Head Office EMC Lab. No.2 Semi Anechoic Chamber
Report No. : 10156278H
Date : 02/15/2014
Temperature/ Humidity : 22 deg. C / 28% RH
Engineer : Hironobu Ohnishi
(1-26.5GHz)
Mode : 11b Tx 2412MHz, Antenna 3

Polarity	Frequency [MHz]	Detector	Reading [dBuV]	Ant.Fac. [dB/m]	Loss [dB]	Gain [dB]	Result [dBuV/m]	Limit [dBuV/m]	Margin [dB]	Remark
Hori	2390.000	PK	51.4	26.8	3.0	34.7	46.5	73.9	27.4	
Hori	3215.988	PK	48.8	27.8	3.6	34.3	45.9	73.9	28.0	
Hori	4824.000	PK	47.3	30.7	5.3	33.9	49.4	73.9	24.5	
Hori	7236.000	PK	43.8	35.6	6.6	33.8	52.2	73.9	21.7	
Hori	9648.000	PK	44.4	38.2	7.0	34.4	55.2	73.9	18.7	
Hori	2390.000	AV	38.1	26.8	3.0	34.7	33.2	53.9	20.7	
Hori	3215.988	AV	44.6	27.8	3.6	34.3	41.7	53.9	12.2	
Hori	4824.000	AV	31.1	30.7	5.3	33.9	33.2	53.9	20.7	
Hori	7236.000	AV	30.8	35.6	6.6	33.8	39.2	53.9	14.7	
Hori	9648.000	AV	31.5	38.2	7.0	34.4	42.3	53.9	11.6	
Vert	2390.000	PK	50.1	26.8	3.0	34.7	45.2	73.9	28.7	
Vert	3215.988	PK	48.5	27.8	3.6	34.3	45.6	73.9	28.3	
Vert	4824.000	PK	47.1	30.7	5.3	33.9	49.2	73.9	24.7	
Vert	7236.000	PK	44.4	35.6	6.6	33.8	52.8	73.9	21.1	
Vert	9648.000	PK	44.9	38.2	7.0	34.4	55.7	73.9	18.2	
Vert	2390.000	AV	37.8	26.8	3.0	34.7	32.9	53.9	21.0	
Vert	3215.988	AV	43.2	27.8	3.6	34.3	40.3	53.9	13.6	
Vert	4824.000	AV	31.1	30.7	5.3	33.9	33.2	53.9	20.7	
Vert	7236.000	AV	30.9	35.6	6.6	33.8	39.3	53.9	14.6	
Vert	9648.000	AV	31.6	38.2	7.0	34.4	42.4	53.9	11.5	

Result = Reading + Ant Factor + Loss (Cable+Attenuator+Filter-Distance factor(above 10GHz)) - Gain(Amplifier)

*Other frequency noises omitted in this report were not seen or had enough margin (more than 20dB).

*The 10th harmonic was not seen so the result was its base noise level.

Distance factor: 10GHz-26.5GHz 20log(3.0m/1.0m)= 9.5dB
26.5GHz-40GHz 20log(3.0m/0.5m)=15.6dB

20dBc Data Sheet

Polarity	Frequency [MHz]	Detector	Reading [dBuV]	Ant Factor [dB/m]	Loss [dB]	Gain [dB]	Result [dBuV/m]	Limit [dBuV/m]	Margin [dB]	Remark
Hori	2412.000	PK	103.8	26.8	3.0	34.7	98.9	-	-	Carrier
Hori	2397.017	PK	60.5	26.8	3.0	34.7	55.6	78.9	23.3	
Hori	2400.000	PK	57.0	26.8	3.0	34.7	52.1	78.9	26.8	
Vert	2412.000	PK	103.7	26.8	3.0	34.7	98.8	-	-	Carrier
Vert	2397.017	PK	60.3	26.8	3.0	34.7	55.4	78.8	23.4	
Vert	2400.000	PK	56.9	26.8	3.0	34.7	52.0	78.8	26.8	

Result = Reading + Ant Factor + Loss (Cable+Attenuator+Filter-Distance factor(above 10GHz)) - Gain(Amplifier)

UL Japan, Inc.

Head Office EMC Lab.

4383-326 Asama-cho, Ise-shi, Mie-ken 516-0021 JAPAN

Telephone : +81 596 24 8999

Facsimile : +81 596 24 8124

Radiated Spurious Emission

Test place Head Office EMC Lab. No.2 Semi Anechoic Chamber
Report No. 10156278H
Date 02/13/2014 02/15/2014
Temperature/ Humidity 23 deg. C / 30% RH 22 deg. C / 28% RH
Engineer Hironobu Ohnishi Hironobu Ohnishi
(1-10GHz) (10-26.5GHz)
Mode 11b Tx 2437MHz, Antenna 3

Polarity	Frequency [MHz]	Detector	Reading [dBuV]	Ant.Fac. [dB/m]	Loss [dB]	Gain [dB]	Result [dBuV/m]	Limit [dBuV/m]	Margin [dB]	Remark
Hori	3249.323	PK	50.3	27.9	3.7	34.2	47.7	73.9	26.2	
Hori	4874.000	PK	47.4	30.8	5.3	33.9	49.6	73.9	24.3	
Hori	7311.000	PK	43.6	35.7	6.7	33.8	52.2	73.9	21.7	
Hori	9748.000	PK	44.4	38.4	7.1	34.5	55.4	73.9	18.5	
Hori	3249.323	AV	46.0	27.9	3.7	34.2	43.4	53.9	10.5	
Hori	4874.000	AV	31.6	30.8	5.3	33.9	33.8	53.9	20.1	
Hori	7311.000	AV	30.6	35.7	6.7	33.8	39.2	53.9	14.7	
Hori	9748.000	AV	31.7	38.4	7.1	34.5	42.7	53.9	11.2	
Vert	3249.323	PK	50.8	27.9	3.7	34.2	48.2	73.9	25.7	
Vert	4874.000	PK	47.0	30.8	5.3	33.9	49.2	73.9	24.7	
Vert	7311.000	PK	44.0	35.7	6.7	33.8	52.6	73.9	21.3	
Vert	9748.000	PK	44.5	38.4	7.1	34.5	55.5	73.9	18.4	
Vert	3249.323	AV	47.5	27.9	3.7	34.2	44.9	53.9	9.0	
Vert	4874.000	AV	31.1	30.8	5.3	33.9	33.3	53.9	20.6	
Vert	7311.000	AV	30.6	35.7	6.7	33.8	39.2	53.9	14.7	
Vert	9748.000	AV	31.7	38.4	7.1	34.5	42.7	53.9	11.2	

Result = Reading + Ant Factor + Loss (Cable+Attenuator+Filter-Distance factor(above 10GHz)) - Gain(Amplifier)

*Other frequency noises omitted in this report were not seen or had enough margin (more than 20dB).

*The 10th harmonic was not seen so the result was its base noise level.
Distance factor: 10GHz-26.5GHz 20log(3.0m/1.0m)= 9.5dB
26.5GHz-40GHz 20log(3.0m/0.5m)=15.6dB

Radiated Spurious Emission

Test place : Head Office EMC Lab. No.2 Semi Anechoic Chamber
Report No. : 10156278H
Date : 02/15/2014
Temperature/ Humidity : 22 deg. C / 28% RH
Engineer : Hironobu Ohnishi
(1-26.5GHz)
Mode : 11b Tx 2462MHz, Antenna 3

Polarity	Frequency [MHz]	Detector	Reading [dBuV]	Ant.Fac. [dB/m]	Loss [dB]	Gain [dB]	Result [dBuV/m]	Limit [dBuV/m]	Margin [dB]	Remark
Hori	2483.500	PK	56.2	26.7	3.1	34.7	51.3	73.9	22.6	
Hori	2487.654	PK	57.3	26.7	3.1	34.7	52.4	73.9	21.5	
Hori	3282.655	PK	49.5	27.9	3.7	34.2	46.9	73.9	27.0	
Hori	4924.000	PK	47.4	31.0	5.3	33.9	49.8	73.9	24.1	
Hori	7386.000	PK	44.8	35.8	6.6	33.8	53.4	73.9	20.5	
Hori	9848.000	PK	45.4	38.6	7.1	34.5	56.6	73.9	17.3	
Hori	2483.500	AV	45.4	26.7	3.1	34.7	40.5	53.9	13.4	
Hori	2487.654	AV	47.2	26.7	3.1	34.7	42.3	53.9	11.6	
Hori	3282.655	AV	44.8	27.9	3.7	34.2	42.2	53.9	11.7	
Hori	4924.000	AV	31.0	31.0	5.3	33.9	33.4	53.9	20.5	
Hori	7386.000	AV	31.2	35.8	6.6	33.8	39.8	53.9	14.1	
Hori	9848.000	AV	31.7	38.6	7.1	34.5	42.9	53.9	11.0	
Vert	2483.500	PK	54.4	26.7	3.1	34.7	49.5	73.9	24.4	
Vert	2487.654	PK	55.9	26.7	3.1	34.7	51.0	73.9	22.9	
Vert	3282.655	PK	47.8	27.9	3.7	34.2	45.2	73.9	28.7	
Vert	4924.000	PK	46.6	31.0	5.3	33.9	49.0	73.9	24.9	
Vert	7386.000	PK	44.5	35.8	6.6	33.8	53.1	73.9	20.8	
Vert	9848.000	PK	44.9	38.6	7.1	34.5	56.1	73.9	17.8	
Vert	2483.500	AV	43.5	26.7	3.1	34.7	38.6	53.9	15.3	
Vert	2487.654	AV	45.3	26.7	3.1	34.7	40.4	53.9	13.5	
Vert	3282.655	AV	43.5	27.9	3.7	34.2	40.9	53.9	13.0	
Vert	4924.000	AV	30.9	31.0	5.3	33.9	33.3	53.9	20.6	
Vert	7386.000	AV	31.2	35.8	6.6	33.8	39.8	53.9	14.1	
Vert	9848.000	AV	31.7	38.6	7.1	34.5	42.9	53.9	11.0	

Result = Reading + Ant Factor + Loss (Cable+Attenuator+Filter-Distance factor(above 10GHz)) - Gain(Amplifier)

*Other frequency noises omitted in this report were not seen or had enough margin (more than 20dB).

*The 10th harmonic was not seen so the result was its base noise level.

Distance factor: 10GHz-26.5GHz 20log(3.0m/1.0m)= 9.5dB
26.5GHz-40GHz 20log(3.0m/0.5m)=15.6dB

UL Japan, Inc.

Head Office EMC Lab.

4383-326 Asama-cho, Ise-shi, Mie-ken 516-0021 JAPAN

Telephone : +81 596 24 8999

Facsimile : +81 596 24 8124

Radiated Spurious Emission

Test place : Head Office EMC Lab. No.2 Semi Anechoic Chamber
Report No. : 10156278H
Date : 02/15/2014
Temperature/ Humidity : 22 deg. C / 28% RH
Engineer : Hironobu Ohnishi
(1-26.5GHz)
Mode : 11g Tx 2412MHz, Antenna 3

Polarity	Frequency [MHz]	Detector	Reading [dBuV]	Ant.Fac. [dB/m]	Loss [dB]	Gain [dB]	Result [dBuV/m]	Limit [dBuV/m]	Margin [dB]	Remark
Hori	2390.000	PK	66.4	26.8	3.0	34.7	61.5	73.9	12.4	
Hori	3215.988	PK	48.9	27.8	3.6	34.3	46.0	73.9	27.9	
Hori	4824.000	PK	47.6	30.7	5.3	33.9	49.7	73.9	24.2	
Hori	7236.000	PK	44.2	35.6	6.6	33.8	52.6	73.9	21.3	
Hori	9648.000	PK	44.6	38.2	7.0	34.4	55.4	73.9	18.5	
Hori	2390.000	AV	50.6	26.8	3.0	34.7	45.7	53.9	8.2	
Hori	3215.988	AV	45.3	27.8	3.6	34.3	42.4	53.9	11.5	
Hori	4824.000	AV	32.5	30.7	5.3	33.9	34.6	53.9	19.3	
Hori	7236.000	AV	30.8	35.6	6.6	33.8	39.2	53.9	14.7	
Hori	9648.000	AV	31.5	38.2	7.0	34.4	42.3	53.9	11.6	
Vert	2390.000	PK	65.7	26.8	3.0	34.7	60.8	73.9	13.1	
Vert	3215.988	PK	48.9	27.8	3.6	34.3	46.0	73.9	27.9	
Vert	4824.000	PK	47.6	30.7	5.3	33.9	49.7	73.9	24.2	
Vert	7236.000	PK	44.3	35.6	6.6	33.8	52.7	73.9	21.2	
Vert	9648.000	PK	44.4	38.2	7.0	34.4	55.2	73.9	18.7	
Vert	2390.000	AV	50.0	26.8	3.0	34.7	45.1	53.9	8.8	
Vert	3215.988	AV	43.5	27.8	3.6	34.3	40.6	53.9	13.3	
Vert	4824.000	AV	32.4	30.7	5.3	33.9	34.5	53.9	19.4	
Vert	7236.000	AV	30.9	35.6	6.6	33.8	39.3	53.9	14.6	
Vert	9648.000	AV	31.6	38.2	7.0	34.4	42.4	53.9	11.5	

Result = Reading + Ant Factor + Loss (Cable+Attenuator+Filter-Distance factor(above 10GHz)) - Gain(Amplifier)

*Other frequency noises omitted in this report were not seen or had enough margin (more than 20dB).

*The 10th harmonic was not seen so the result was its base noise level.
Distance factor: 10GHz-26.5GHz 20log(3.0m/1.0m)= 9.5dB
26.5GHz-40GHz 20log(3.0m/0.5m)=15.6dB

20dBc Data Sheet

Polarity	Frequency [MHz]	Detector	Reading [dBuV]	Ant Factor [dB/m]	Loss [dB]	Gain [dB]	Result [dBuV/m]	Limit [dBuV/m]	Margin [dB]	Remark
Hori	2412.000	PK	99.9	26.8	3.0	34.7	95.0	-	-	Carrier
Hori	2400.000	PK	69.1	26.8	3.0	34.7	64.2	75.0	10.8	
Vert	2412.000	PK	99.5	26.8	3.0	34.7	94.6	-	-	Carrier
Vert	2400.000	PK	68.9	26.8	3.0	34.7	64.0	74.6	10.6	

Result = Reading + Ant Factor + Loss (Cable+Attenuator+Filter-Distance factor(above 10GHz)) - Gain(Amplifier)

UL Japan, Inc.

Head Office EMC Lab.

4383-326 Asama-cho, Ise-shi, Mie-ken 516-0021 JAPAN

Telephone : +81 596 24 8999

Facsimile : +81 596 24 8124

Radiated Spurious Emission

Test place	Head Office EMC Lab. No.2 Semi Anechoic Chamber	
Report No.	10156278H	
Date	02/13/2014	02/15/2014
Temperature/ Humidity	23 deg. C / 30% RH	22 deg. C / 28% RH
Engineer	Hironobu Ohnishi	Hironobu Ohnishi
	(1-10GHz)	(30-1000MHz), (10-26.5GHz)
Mode	11g Tx 2437MHz, Antenna 3	

Polarity	Frequency [MHz]	Detector	Reading [dBuV]	Ant.Fac. [dB/m]	Loss [dB]	Gain [dB]	Result [dBuV/m]	Limit [dBuV/m]	Margin [dB]	Remark
Hori	38.000	QP	22.8	15.2	6.8	28.6	16.2	40.0	23.8	
Hori	249.998	QP	37.2	17.1	8.5	27.7	35.1	46.0	10.9	
Hori	411.425	QP	36.7	17.4	9.4	28.4	35.1	46.0	10.9	
Hori	499.995	QP	30.4	18.1	9.8	28.8	29.5	46.0	16.5	
Hori	611.312	QP	24.5	19.6	10.2	28.8	25.5	46.0	20.5	
Hori	807.333	QP	28.3	21.8	10.9	28.2	32.8	46.0	13.2	
Hori	3249.323	PK	48.6	27.9	3.7	34.2	46.0	73.9	27.9	
Hori	4874.000	PK	47.9	30.8	5.3	33.9	50.1	73.9	23.8	
Hori	7311.000	PK	44.0	35.7	6.7	33.8	52.6	73.9	21.3	
Hori	9748.000	PK	44.5	38.4	7.1	34.5	55.5	73.9	18.4	
Hori	3249.323	AV	44.7	27.9	3.7	34.2	42.1	53.9	11.8	
Hori	4874.000	AV	32.3	30.8	5.3	33.9	34.5	53.9	19.4	
Hori	7311.000	AV	30.6	35.7	6.7	33.8	39.2	53.9	14.7	
Hori	9748.000	AV	31.7	38.4	7.1	34.5	42.7	53.9	11.2	
Vert	38.000	QP	22.9	15.2	6.8	28.6	16.3	40.0	23.7	
Vert	249.998	QP	36.2	17.1	8.5	27.7	34.1	46.0	11.9	
Vert	411.425	QP	38.8	17.4	9.4	28.4	37.2	46.0	8.8	
Vert	499.995	QP	30.5	18.1	9.8	28.8	29.6	46.0	16.4	
Vert	611.312	QP	27.3	19.6	10.2	28.8	28.3	46.0	17.7	
Vert	807.333	QP	25.2	21.8	10.9	28.2	29.7	46.0	16.3	
Vert	3249.323	PK	48.3	27.9	3.7	34.2	45.7	73.9	28.2	
Vert	4874.000	PK	47.2	30.8	5.3	33.9	49.4	73.9	24.5	
Vert	7311.000	PK	43.5	35.7	6.7	33.8	52.1	73.9	21.8	
Vert	9748.000	PK	44.6	38.4	7.1	34.5	55.6	73.9	18.3	
Vert	3249.323	AV	44.0	27.9	3.7	34.2	41.4	53.9	12.5	
Vert	4874.000	AV	32.4	30.8	5.3	33.9	34.6	53.9	19.3	
Vert	7311.000	AV	30.6	35.7	6.7	33.8	39.2	53.9	14.7	
Vert	9748.000	AV	31.7	38.4	7.1	34.5	42.7	53.9	11.2	

Result = Reading + Ant Factor + Loss (Cable+Attenuator+Filter-Distance factor(above 10GHz)) - Gain(Amplifier)

*Other frequency noises omitted in this report were not seen or had enough margin (more than 20dB).

*The 10th harmonic was not seen so the result was its base noise level.
Distance factor: 10GHz-26.5GHz 20log(3.0m/1.0m)= 9.5dB
26.5GHz-40GHz 20log(3.0m/0.5m)=15.6dB

Radiated Spurious Emission

Test place : Head Office EMC Lab. No.2 Semi Anechoic Chamber
Report No. : 10156278H
Date : 02/15/2014
Temperature/ Humidity : 22 deg. C / 28% RH
Engineer : Hironobu Ohnishi
(1-26.5GHz)
Mode : 11g Tx 2462MHz, Antenna 3

Polarity	Frequency [MHz]	Detector	Reading [dBuV]	Ant.Fac. [dB/m]	Loss [dB]	Gain [dB]	Result [dBuV/m]	Limit [dBuV/m]	Margin [dB]	Remark
Hori	2483.500	PK	71.2	26.7	3.1	34.7	66.3	73.9	7.6	
Hori	3282.655	PK	49.3	27.9	3.7	34.2	46.7	73.9	27.2	
Hori	4924.000	PK	47.6	31.0	5.3	33.9	50.0	73.9	23.9	
Hori	7386.000	PK	44.2	35.8	6.6	33.8	52.8	73.9	21.1	
Hori	9848.000	PK	44.8	38.6	7.1	34.5	56.0	73.9	17.9	
Hori	2483.500	AV	55.4	26.7	3.1	34.7	50.5	53.9	3.4	
Hori	3282.655	AV	45.0	27.9	3.7	34.2	42.4	53.9	11.5	
Hori	4924.000	AV	32.4	31.0	5.3	33.9	34.8	53.9	19.1	
Hori	7386.000	AV	31.2	35.8	6.6	33.8	39.8	53.9	14.1	
Hori	9848.000	AV	31.7	38.6	7.1	34.5	42.9	53.9	11.0	
Vert	2483.500	PK	68.7	26.7	3.1	34.7	63.8	73.9	10.1	
Vert	3282.655	PK	48.4	27.9	3.7	34.2	45.8	73.9	28.1	
Vert	4924.000	PK	47.0	31.0	5.3	33.9	49.4	73.9	24.5	
Vert	7386.000	PK	44.1	35.8	6.6	33.8	52.7	73.9	21.2	
Vert	9848.000	PK	44.6	38.6	7.1	34.5	55.8	73.9	18.1	
Vert	2483.500	AV	52.9	26.7	3.1	34.7	48.0	53.9	5.9	
Vert	3282.655	AV	43.6	27.9	3.7	34.2	41.0	53.9	12.9	
Vert	4924.000	AV	31.8	31.0	5.3	33.9	34.2	53.9	19.7	
Vert	7386.000	AV	31.2	35.8	6.6	33.8	39.8	53.9	14.1	
Vert	9848.000	AV	31.7	38.6	7.1	34.5	42.9	53.9	11.0	

Result = Reading + Ant Factor + Loss (Cable+Attenuator+Filter-Distance factor(above 10GHz)) - Gain(Amplifier)

*Other frequency noises omitted in this report were not seen or had enough margin (more than 20dB).

*The 10th harmonic was not seen so the result was its base noise level.
Distance factor: 10GHz-26.5GHz 20log(3.0m/1.0m)= 9.5dB
26.5GHz-40GHz 20log(3.0m/0.5m)=15.6dB

Radiated Spurious Emission

Test place : Head Office EMC Lab. No.2 Semi Anechoic Chamber
Report No. : 10156278H
Date : 02/15/2014
Temperature/ Humidity : 22 deg. C / 28% RH
Engineer : Hironobu Ohnishi
Mode : 11n-20 Tx 2412MHz (Band edge only), Antenna 3

Polarity	Frequency [MHz]	Detector	Reading [dBuV]	Ant.Fac. [dB/m]	Loss [dB]	Gain [dB]	Result [dBuV/m]	Limit [dBuV/m]	Margin [dB]	Remark
Hori	2390.000	PK	67.4	26.8	3.0	34.7	62.5	73.9	11.4	
Hori	2390.000	AV	52.4	26.8	3.0	34.7	47.5	53.9	6.4	
Vert	2390.000	PK	66.9	26.8	3.0	34.7	62.0	73.9	11.9	
Vert	2390.000	AV	51.7	26.8	3.0	34.7	46.8	53.9	7.1	

Result = Reading + Ant Factor + Loss (Cable+Attenuator+Filter-Distance factor(above 10GHz)) - Gain(Amplifier)

*Other frequency noises omitted in this report were not seen or had enough margin (more than 20dB).

Distance factor: 10GHz-26.5GHz $20\log(3.0\text{m}/1.0\text{m})= 9.5\text{dB}$
 26.5GHz-40GHz $20\log(3.0\text{m}/0.5\text{m})=15.6\text{dB}$

20dBc Data Sheet

Polarity	Frequency [MHz]	Detector	Reading [dBuV]	Ant Factor [dB/m]	Loss [dB]	Gain [dB]	Result [dBuV/m]	Limit [dBuV/m]	Margin [dB]	Remark
Hori	2412.000	PK	99.8	26.8	3.0	34.7	94.9	-	-	Carrier
Hori	2400.000	PK	70.3	26.8	3.0	34.7	65.4	74.9	9.5	
Vert	2412.000	PK	99.3	26.8	3.0	34.7	94.4	-	-	Carrier
Vert	2400.000	PK	69.9	26.8	3.0	34.7	65.0	74.4	9.4	

Result = Reading + Ant Factor + Loss (Cable+Attenuator+Filter-Distance factor(above 10GHz)) - Gain(Amplifier)

UL Japan, Inc.

Head Office EMC Lab.

4383-326 Asama-cho, Ise-shi, Mie-ken 516-0021 JAPAN

Telephone : +81 596 24 8999

Facsimile : +81 596 24 8124

Radiated Spurious Emission

Test place Head Office EMC Lab. No.2 Semi Anechoic Chamber
Report No. 10156278H
Date 02/15/2014
Temperature/ Humidity 22 deg. C / 28% RH
Engineer Hironobu Ohnishi
Mode 11n-20 Tx 2462MHz (Band edge only), Antenna 3

Polarity	Frequency [MHz]	Detector	Reading [dBuV]	Ant.Fac. [dB/m]	Loss [dB]	Gain [dB]	Result [dBuV/m]	Limit [dBuV/m]	Margin [dB]	Remark
Hori	2483.500	PK	70.9	26.7	3.1	34.7	66.0	73.9	7.9	
Hori	2483.500	AV	55.7	26.7	3.1	34.7	50.8	53.9	3.1	
Vert	2483.500	PK	68.9	26.7	3.1	34.7	64.0	73.9	9.9	
Vert	2483.500	AV	53.2	26.7	3.1	34.7	48.3	53.9	5.6	

Result = Reading + Ant Factor + Loss (Cable+Attenuator+Filter-Distance factor(above 10GHz)) - Gain(Amplifier)

*Other frequency noises omitted in this report were not seen or had enough margin (more than 20dB).

Distance factor: 10GHz-26.5GHz $20\log(3.0\text{m}/1.0\text{m})= 9.5\text{dB}$
26.5GHz-40GHz $20\log(3.0\text{m}/0.5\text{m})=15.6\text{dB}$

UL Japan, Inc.

Head Office EMC Lab.

4383-326 Asama-cho, Ise-shi, Mie-ken 516-0021 JAPAN

Telephone : +81 596 24 8999

Facsimile : +81 596 24 8124

Burst rate confirmation

Test place	Head Office EMC Lab. No.2 Semi Anechoic Chamber
Report No.	10156278H
Date	02/15/2014
Temperature/ Humidity	22 deg. C / 28% RH
Engineer	Hironobu Ohnishi
Mode	Tx

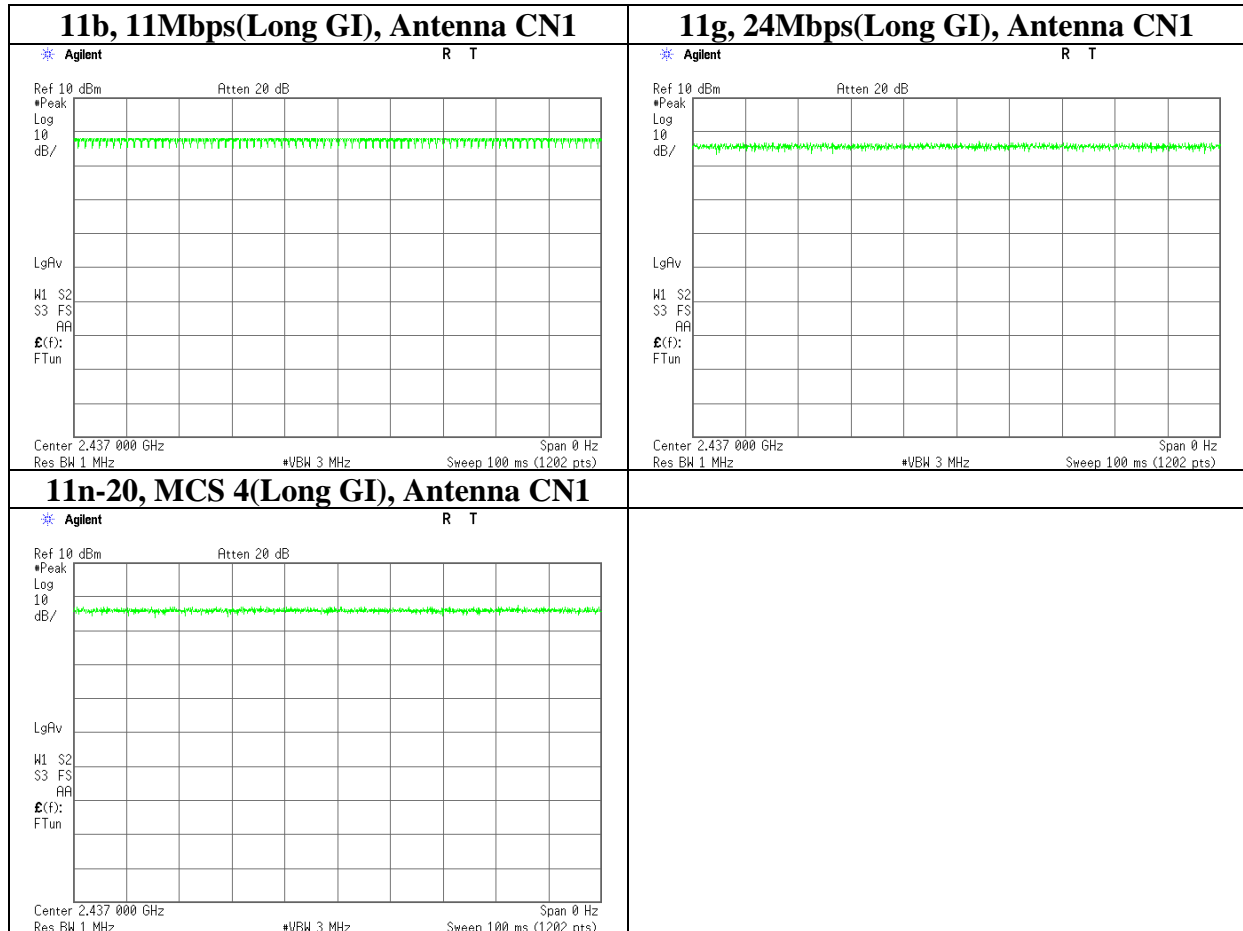

APPENDIX 2: Test instruments

EMI test equipment

Control No.	Instrument	Manufacturer	Model No	Serial No	Test Item	Calibration Date * Interval(month)
MOS-22	Thermo-Hygrometer	Custom	CTH-201	0003	RE/CE	2013/02/26 * 12
MJM-14	Measure	KOMELON	KMC-36	-	RE/CE	-
COTS-MEMI	EMI measurement program	TSJ	TEPTO-DV	-	RE/CE	-
MRENT-95	Spectrum Analyzer	Agilent	E4440A	MY46185823	RE/CE	2013/06/14 * 12
MHA-06	Horn Antenna 1-18GHz	Schwarzbeck	BBHA9120D	254	RE	2013/02/15 * 12
MCC-166	Microwave Cable	Junkosha	MWX221	1303S120(1m) / 1311S167(5m)	RE	2013/11/27 * 12
MPA-10	Pre Amplifier	Agilent	8449B	3008A02142	RE	2014/01/21 * 12
MHF-25	High Pass Filter 3.5-18.0GHz	UL Japan	HPF SELECTOR	001	RE	2013/09/01 * 12
MHA-02	Horn Antenna 18-26.5GHz	EMCO	3160-09	1265	RE	2013/02/15 * 12
MTR-03	Test Receiver	Rohde & Schwarz	ESCI	100300	RE/CE	2013/06/11 * 12
MBA-02	Biconical Antenna	Schwarzbeck	BBA9106	VHA91032008	RE	2013/10/13 * 12
MLA-02	Logperiodic Antenna	Schwarzbeck	USLP9143	201	RE	2013/10/13 * 12
MCC-12	Coaxial Cable	Fujikura/Agilent	-	-	RE	2013/02/06 * 12
MAT-07	Attenuator(6dB)	Weinschel Corp	2	BK7970	RE	2013/11/26 * 12
MPA-09	Pre Amplifier	Agilent	8447D	2944A10845	RE	2013/09/12 * 12
MLS-07	LISN(AMN)	Schwarzbeck	NSLK8127	8127364	CE	2014/01/27 * 12
MJG-50	Extension Tap US	UL Japan			CE	-
MCC-13	Coaxial Cable	Fujikura	3D-2W(12m)/5D-2W(5m)/5D-2W(0.8m)/5D-2W(1m)	-	CE	2013/02/06 * 12
MAT-65	Attenuator(13dB)	JFW Industries, Inc.	50FP-013H2 N	-	CE	2014/01/29 * 12
MAEC-03	Semi Anechoic Chamber(NSA)	TDK	Semi Anechoic Chamber 3m	DA-10005	RE	2013/02/28 * 12
MOS-13	Thermo-Hygrometer	Custom	CTH-180	-	RE	2013/02/26 * 12
MJM-16	Measure	KOMELON	KMC-36	-	RE	-
MSA-04	Spectrum Analyzer	Agilent	E4448A	US44300523	CE/RE	2013/11/25 * 12
MHA-20	Horn Antenna 1-18GHz	Schwarzbeck	BBHA9120D	258	RE	2013/05/17 * 12
MCC-133	Microwave Cable	HUBER+SUHNER	SUCOFLEX104	336164/4(1m) / 340640(5m)	RE	2013/09/27 * 12
MPA-11	MicroWave System Amplifier	Agilent	83017A	MY39500779	RE	2013/03/12 * 12
MAEC-02	Semi Anechoic Chamber(NSA)	TDK	Semi Anechoic Chamber 3m	DA-06902	CE/RE	2013/06/30 * 12

The expiration date of the calibration is the end of the expired month.

All equipment is calibrated with valid calibrations. Each measurement data is traceable to the national or international standards.

As for some calibrations performed after the tested dates, those test equipment have been controlled by means of an unbroken chains of calibrations.

Test Item: CE: Conducted Emission,

RE: Radiated Emission

UL Japan, Inc.

Head Office EMC Lab.

4383-326 Asama-cho, Ise-shi, Mie-ken 516-0021 JAPAN

Telephone : +81 596 24 8999

Facsimile : +81 596 24 8124