

# DYNAMIC FREQUENCY SELECTION DFS TEST REPORT

For

**SX-PCEAC-DB Rev2**

**Model: SX-PCEAC-DB, SX-PCEAC**

*Issued to*

**silex technology, Inc.  
2-3-1 Hikaridai, Seika-cho, Souraku-gun, Kyoto 619-0237,  
Japan**

*Issued by*

**Compliance Certification Services Inc.  
Wugu Laboratory  
No.11, Wugong 6th Rd., Wugu Dist.,  
New Taipei City, Taiwan. (R.O.C.)  
Issued Date: April 17, 2020**

Unless otherwise stated the results shown in this test report refer only to the sample(s) tested and such sample(s) are retained for 90 days only.  
除非另有說明，此報告結果僅對測試之樣品負責，同時此樣品僅保留90天。本報告未經本公司書面許可，不可部分複製。

This document is issued by the Company subject to its General Conditions of Service printed overleaf, available on request or accessible at [www.sgs.com/terms\\_and\\_conditions.htm](http://www.sgs.com/terms_and_conditions.htm) and for electronic format documents, subject to Terms and Conditions for Electronic Documents at [www.sgs.com/terms\\_e-document.htm](http://www.sgs.com/terms_e-document.htm). Attention is drawn to the limitation of liability, indemnification and jurisdiction issues defined therein. Any holder of this document is advised that information contained hereon reflects the Company's findings at the time of its intervention only and within the limits of Client's instructions, if any. The Company's sole responsibility is to its Client and this document does not exonerate parties to a transaction from exercising all their rights and obligations under the transaction documents. This document cannot be reproduced except in full, without prior written approval of the Company. Any unauthorized alteration, forgery or falsification of the content or appearance of this document is unlawful and offenders may be prosecuted to the fullest extent of the law.



Report No.: T200205W01-RP1

Page: 2 / 58  
Rev.: 00

**Revision History**

Rev.	Issue Date	Revisions	Effect Page	Revised By
00	April 17, 2020	Initial Issue	ALL	Doris Chu

## TABLE OF CONTENTS

<b>1. CERTIFICATION OF CONFORMITY.....</b>	<b>5</b>
<b>2. GENERAL DESCRIPTION .....</b>	<b>6</b>
2.1 PRODUCT DESCRIPTION .....	6
2.2 FEATURE OF EQUIPMENT UNDER TEST.....	8
2.3 SUPPORT UNIT USED IN TEST CONFIGURATION AND SYSTEM.....	8
<b>3. REQUIREMENTS AND PARAMETERS FOR DFS TEST.....</b>	<b>9</b>
3.1 APPLICABILITY OF DFS REQUIREMENTS .....	9
3.2 DFS DETECTION THRESHOLDS .....	10
3.3 DFS RESPONSE REQUIREMENT .....	11
3.4 RADAR TEST WAVEFORMS .....	12
<b>4. CALIBRATION SETUP AND DFS TEST SETUP CONFIGURATION.....</b>	<b>17</b>
4.1 RADIATED TEST SETUP CONFIGURATION .....	17
4.2 CALIBATION OF RADAR WAVEFORM.....	18
<b>5. DFS TSET RESULT.....</b>	<b>19</b>
5.1 RADAR WAVEFORM CALIBRATION RESULT .....	19
5.2 U-NII DETECTION BANDWIDTH (7.8.1) .....	31
5.3 CHANNEL AVAILABILITY CHECK (7.8.2).....	37
5.4 IN-SERVICE MONITORING: CHANNEL MOVE TIME, CHANNEL CLOSING TRANSMISSION TIME AND NON-OCCUPANCY PERIOD (7.8.3).....	42
5.5 STATISTICAL PERFORMANCE CHECK (7.8.4) .....	47
<b>6. MEASUREMENT EQUIPMENT LIST &amp; CALIBRATION STATUS.....</b>	<b>58</b>
<b>APPENDIX I RADAR TEST WAVEFORMS.....</b>	<b>A-1</b>
<b>APPENDIX II TEST SETUP PHOTO .....</b>	<b>B-1</b>

### Summary of Dynamic Frequency of Selection Test

UNII	Description	Limit	Result
U-NII Band 2-A 5250-5350MHz	Channel Availability Check Time	> 60sec	Pass
	U-NII Detection Bandwidth	> 100% of the U-NII 99% transmission power bandwidth	Pass
	Statistical Performance Check	Type 1,2,3,4 >= 60% Type 1~4 and 5 >= 80% Type 6 >= 70%	Pass
	Channel Move Time	< 10 sec	Pass
	Channel Closing Transmission Time	< 200 ms + aggregate of 60 ms over remaining 10 s period	Pass
	Non-Occupancy Period Test	> 30 minutes	Pass
U-NII Band 2-C 5470-5725MHz	Channel Availability Check Time	> 60sec	Pass
	U-NII Detection Bandwidth	> 100% of the U-NII 99% transmission power bandwidth	Pass
	Statistical Performance Check	Type 1,2,3,4 >= 60% Type 1~4 and 5 >= 80% Type 6 >= 70%	Pass
	Channel Move Time	< 10 sec	Pass
	Channel Closing Transmission Time	< 200 ms + aggregate of 60 ms over remaining 10 s period	Pass
	Non-Occupancy Period Test	> 30 minutes	Pass

## 1. Certification of Conformity

**Applicant:** silex technology, Inc.  
2-3-1 Hikaridai, Seika-cho, Souraku-gun, Kyoto 619-0237,  
Japan

**Manufacturer:** silex technology, Inc.  
2-3-1 Hikaridai, Seika-cho, Souraku-gun, Kyoto 619-0237,  
Japan

**Equipment Under Test:** SX-PCEAC-DB Rev2

**Model Name:** SX-PCEAC-DB, SX-PCEAC

**Trade Name:** SILEX TECHNOLOGY

**Date of Test:** February 7 ~ 14, 2020

<b>APPLICABLE STANDARDS</b>
FCC 47 CFR Part 15 Subpart E (Section 15.407) KDB 905462 D02 UNII DFS Compliance Procedures New Rules v02 KDB 905462 D04 Operational Modes for DFS Testing New Rules v01
<b>TEST RESULT</b>
No non-compliance noted
<b>Statements of Conformity</b>
Determination of compliance is based on the results of the compliance measurement, not taking into account measurement instrumentation uncertainty.

### We hereby certify that:

Compliance Certification Services Inc. tested the above equipment. The test data, data evaluation, test procedures, and equipment configurations shown in this report were made in accordance with the procedures given in ANSI C63.4: 2014 & ANSI C63.10: 2013 and the energy emitted by the sample EUT tested as described in this report is in compliance with conducted and radiated emission limits of FCC Rules Part 15.407.

The test results of this report relate only to the tested sample identified in this report.

Approved by:



---

Kevin Tsai  
Deputy Manager  
Compliance Certification Services Inc.

## 2. General Description

### 2.1 Product Description

<b>Product Name</b>	SX-PCEAC-DB Rev2
<b>Model Name</b>	SX-PCEAC-DB, SX-PCEAC
<b>Trade Name</b>	SILEX TECHNOLOGY
<b>Model Discrepancy</b>	SX-PCEAC-DB works on 2.4GHz and 5GHz, SX-PCEAC does on 5GHz only. It is controlled by driver software.
<b>Power Operation</b>	Power from Power Adapter. I/P: 100-240VAC, 50-60Hz, 1A MAX. O/P: 12VDC, 3A
<b>Product H/W Version:</b>	PW104021XX
<b>Product F/W Version:</b>	10.2-00082-4
<b>Product S/W version:</b>	Ver.1

<p><b>Antenna Designation</b></p>	<ol style="list-style-type: none"> <li>1. STAF / 1019-015A ROD Antenna / 4 dBi</li> <li>2. Sansei Denki / ANTDC-081A0 ROD Antenna / 2 dBi</li> <li>3. Sansei Denki / ANTDP-027A0 ROD Antenna / 2.1 dBi</li> <li>4. JOYMAX / KWM-619BMPXX ROD Antenna / 3.81 dBi</li> <li>5. Molex / 146153 PCB Antenna / 5 dBi</li> <li>6. Unictron / H2B1PC1A1C (AA258) PCB Antenna / 4.4 dBi</li> <li>7. Unictron / H2B1PD1A1C (AA222) PCB Antenna / 4.2 dBi</li> </ol>
<p><b>Modulation type</b></p>	<ol style="list-style-type: none"> <li>1. IEEE 802.11a mode: OFDM</li> <li>2. IEEE 802.11n HT 20 MHz mode: OFDM</li> <li>3. IEEE 802.11n HT 40 MHz mode: OFDM</li> <li>4. IEEE 802.11ac VHT 80 MHz mode: OFDM</li> </ol>
<p><b>Transition Rate</b></p>	<p>802.11 a: 6/9/12/18/24/36/48/54 Mbps              802.11 n_20MHz: 6.5 – 144.4Mbps              802.11 n_40MHz: 13.5 – 300Mbps              802.11 ac_80MHz: 29.3 – 650Mbps</p>

## 2.2 Feature of Equipment Under Test

Product Feature	
Product Name	SX-PCEAC-DB Rev2
Model Name	SX-PCEAC-DB, SX-PCEAC
Trade Name	SILEX TECHNOLOGY
EUT supports Radios application	WLAN 11a/b/g/n HT20/HT40 WLAN 11ac VHT20/VHT40/VHT80
DFS Function	Master

*Remark: 1. The sample selected for test was engineering sample that approximated to production product and was provided by manufacturer.*

## 2.3 Support Unit used in test configuration and system

Item	Equipment	Trade Name	Model Name	FCC ID
	N/A			



### 3. Requirements and Parameters for DFS Test

#### 3.1 Applicability of DFS Requirements

EUT is considered as a master device.

**Table 1: Applicability of DFS Requirements Prior to Use of a Channel**

Requirement	Operational Mode		
	Master	Client Without Radar Detection	Client With Radar Detection
Non-Occupancy Period	Yes	Not required	Yes
DFS Detection Threshold	Yes	Not required	Yes
Channel Availability Check Time	Yes	Not required	Not required
U-NII Detection Bandwidth	Yes	Not required	Yes

**Table 2: Applicability of DFS requirements during normal operation**

Requirement	Operational Mode	
	Master	Client Without Radar Detection
DFS Detection Threshold	Yes	Not required
Channel Closing Transmission Time	Yes	Yes
Channel Move Time	Yes	Yes
U-NII Detection Bandwidth	Yes	Not required

Additional requirements for devices with multiple bandwidth modes	Operational Mode	
	Master Device or Client With Radar Detection	Client Without Radar Detection
U-NII Detection Bandwidth and Statistical Performance Check	All BW modes must be tested	Not required
Channel Move Time and Channel Closing Transmission Time	Test using widest BW mode available	Test using the widest BW mode available for the link
All other tests	Any single BW mode	Not required

**Note:** Frequencies selected for statistical performance check (Section 7.8.4) should include several frequencies within the radar detection bandwidth and frequencies near the edge of the radar detection bandwidth. For 802.11 devices it is suggested to select frequencies in each of the bonded 20 MHz channels and the channel center frequency.

### 3.2 DFS Detection Thresholds

Table 3 below provides the DFS Detection Thresholds for Master Devices as well as Client Devices incorporating In-Service Monitoring.

**Table 3: DFS Detection Thresholds for Master Devices**

Maximum Transmit Power	Value (see notes 1, 2, and 3)
EIRP $\geq$ 200 milliwatt	-64 dBm
EIRP < 200 milliwatt and power spectral density < 10 dBm/MHz	-62 dBm
EIRP < 200 milliwatt that do not meet the power spectral density requirement	-64 dBm

**Note 1:** This is the level at the input of the receiver assuming a 0 dBi receive antenna.  
**Note 2:** Throughout these test procedures an additional 1 dB has been added to the amplitude of the test transmission waveforms to account for variations in measurement equipment. This will ensure that the test signal is at or above the detection threshold level to trigger a DFS response.  
**Note 3:** EIRP is based on the highest antenna gain. For MIMO devices refer to KDB Publication 662911 D01.

### 3.3 DFS Response requirement

Table 4 provides the response requirements for Master and Client Devices incorporating DFS.

**Table 4: DFS Response Requirement Values**

Parameter	Value
<i>Non-occupancy period</i>	Minimum 30 minutes
<i>Channel Availability Check Time</i>	60 seconds
<i>Channel Move Time</i>	10 seconds See Note 1.
<i>Channel Closing Transmission Time</i>	200 milliseconds + an aggregate of 60 milliseconds over remaining 10 second periods. See Notes 1 and 2.
<i>U-NII Detection Bandwidth</i>	Minimum 100% of the 99% power bandwidth See Note 3.

**Note 1:** *Channel Move Time* and the *Channel Closing Transmission Time* should be performed with Radar Type 0. The measurement timing begins at the end of the Radar Type 0 burst.

**Note 2:** The *Channel Closing Transmission Time* is comprised of 200 milliseconds starting at the beginning of the *Channel Move Time* plus any additional intermittent control signals required to facilitate *Channel* changes (an aggregate of 60 milliseconds) during the remainder of the 10 second period. The aggregate duration of control signals will not count quiet periods in between transmissions.

**Note 3:** During the *U-NII Detection Bandwidth* detection test, radar type 0 is used and for each frequency step the minimum percentage of detection is 90%. Measurements are performed with no data traffic.

### 3.4 Radar Test Waveforms

This section provides the parameters for required test waveforms, minimum percentage of successful detections, and the minimum number of trials that must be used for determining DFS conformance. Step intervals of 0.1 microsecond for Pulse Width, 1 microsecond for PRI, 1 MHz for chirp width and 1 for the number of pulses will be utilized for the random determination of specific test waveforms.

#### 3.4.1 Short Pulse Radar Test Waveforms

Radar Type 0 was used in the evaluation of the Client device for the purpose of measuring the Channel Move Time and the Channel Closing Transmission Time.

**Table 5 – Short Pulse Radar Test Waveforms**

Radar Type	Pulse Width (μsec)	PRI (μsec)	Number of Pulses	Minimum Percentage of Successful Detection	Minimum Number of Trials
0	1	1428	18	See Note 1	
1	1	Test A	$\text{Roundup}\left\{\left(\frac{1}{360}\right) \cdot \left(\frac{19 \cdot 10^6}{PRI_{\mu\text{sec}}}\right)\right\}$	60%	30
		Test B			
2	1-5	150-230	23-29	60%	30
3	6-10	200-500	16-18	60%	30
4	11-20	200-500	12-16	60%	30
Aggregate (Radar Types 1-4)				80%	120
<p><b>Note 1:</b> Short Pulse Radar Type 0 should be used for the detection bandwidth test, channel move time, and channel closing time tests.</p>					

Test A: 15 unique PRI values randomly selected from the list of 23 PRI values in Table 5a

Test B: 15 unique PRI values randomly selected within the range of 518-3066  $\mu$ sec, with a minimum increment of 1  $\mu$ sec, excluding PRI values selected in Test A

A minimum of 30 unique waveforms are required for each of the Short Pulse Radar Types 2 through 4. If more than 30 waveforms are used for Short Pulse Radar Types 2 through 4, then each additional waveform must also be unique and not repeated from the previous waveforms.

If more than 30 waveforms are used for Short Pulse Radar Type 1, then each additional waveform is generated with Test B and must also be unique and not repeated from the previous waveforms in Tests A or B.

The aggregate is the average of the percentage of successful detections of short pulse radar types 1-4.

**Table 5a - Pulse Repetition Intervals Values for Test A**

Pulse Repetition Frequency Number	Pulse Repetition Frequency (Pulses Per Second)	Pulse Repetition Interval (Microseconds)
1	1930.5	518
2	1858.7	538
3	1792.1	558
4	1730.1	578
5	1672.2	598
6	1618.1	618
7	1567.4	638
8	1519.8	658
9	1474.9	678
10	1432.7	698
11	1392.8	718
12	1355	738
13	1319.3	758
14	1285.3	778
15	1253.1	798
16	1222.5	818
17	1193.3	838
18	1165.6	858
19	1139	878
20	1113.6	898
21	1089.3	918
22	1066.1	938
23	326.2	3066

Report No.: T200205W01-RP1

### 3.4.2 Long Pulse Radar Test Waveform

**Table 6 – Long Pulse Radar Test Waveforms**

Radar Type	Pulse Width (µsec)	Chirp Width (MHz)	PRI (µsec)	Number of Pulses per Burst	Number of Bursts	Minimum Percentage of Successful Detection	Minimum Number of Trials
5	50-100	5-20	1000-2000	1-3	8-20	80%	30

The parameters for this waveform are randomly chosen. Thirty unique waveforms are required for the Long Pulse radar test signal. If more than 30 waveforms are used for the Long Pulse radar test signal, then each additional waveform must also be unique and not repeated from the previous waveforms.

Each waveform is defined as follows:

Note: The center frequency for each of the 30 trials of the Bin 5 radar shall be randomly selected within 80% of the Occupied Bandwidth.

- (1) The transmission period for the Long Pulse Radar test signal is 12 seconds.
- (2) There are a total of 8 to 20 Bursts in the 12 second period, with the number of Bursts being randomly chosen. This number is Burst\_Count.
- (3) Each Burst consists of 1 to 3 pulses, with the number of pulses being randomly chosen. Each Burst within the 12 second sequence may have a different number of pulses.
- (4) The pulse width is between 50 and 100 microseconds, with the pulse width being randomly chosen. Each pulse within a Burst will have the same pulse width. Pulses in different Bursts may have different pulse widths.
- (5) Each pulse has a linear frequency modulated chirp between 5 and 20 MHz, with the chirp width being randomly chosen. Each pulse within a **transmission period** will have the same chirp width. The chirp is centered on the pulse. For example, with a radar frequency of 5300 MHz and a 20 MHz chirped signal, the chirp starts at 5290 MHz and ends at 5310 MHz
- (6) If more than one pulse is present in a Burst, the time between the pulses will be between 1000 and 2000 microseconds, with the time being randomly chosen. If three pulses are present in a Burst, the time between the first and second pulses is chosen independently of the time between the second and third pulses.
- (7) The 12 second transmission period is divided into even intervals. The number of intervals is equal to Burst\_Count. Each interval is of length  $(12,000,000 / \text{Burst\_Count})$  microseconds. Each interval contains one Burst. The start time for the Burst, relative to the beginning of the interval, is between 1 and  $[(12,000,000 / \text{Burst\_Count}) - (\text{Total Burst Length}) + (\text{One Random PRI Interval})]$  microseconds, with the start time being randomly chosen. The step interval for the start time is 1 microsecond. The start time for each Burst is chosen independently.

Report No.: T200205W01-RP1

**A representative example of a Long Pulse radar test waveform:**

- (1) The total test signal length is 12 seconds.
- (2) 8 Bursts are randomly generated for the Burst\_Count.
- (3) Burst 1 has 2 randomly generated pulses.
- (4) The pulse width (for both pulses) is randomly selected to be 75 microseconds.
- (5) The PRI is randomly selected to be at 1213 microseconds.
- (6) Bursts 2 through 8 are generated using steps 3 – 5.
- (7) Each Burst is contained in even intervals of 1,500,000 microseconds. The starting location for Pulse 1, Burst 1 is randomly generated (1 to 1,500,000 minus the total Burst 1 length + 1 random PRI interval) at the 325,001 microsecond step. Bursts 2 through 8 randomly fall in successive 1,500,000 microsecond intervals (i.e. Burst 2 falls in the 1,500,001 – 3,000,000 microsecond range).

### 3.4.3 Frequency Hopping Radar Test Waveform

**Table 7 – Frequency Hopping Radar Test Signal**

Radar Type	Pulse Width (µsec)	PRI (µsec)	Pulses per Hop	Hopping Rate (kHz)	Hopping Sequence Length (msec)	Minimum Percentage of Successful Detection	Minimum Number of Trials
6	1	333	9	0.333	300	70%	30

For the Frequency Hopping Radar Type, the same Burst parameters are used for each waveform. The hopping sequence is different for each waveform and a 100-length segment is selected from the hopping sequence defined by the following algorithm:

The first frequency in a hopping sequence is selected randomly from the group of 475 integer frequencies from 5250 – 5724 MHz. Next, the frequency that was just chosen is removed from the group and a frequency is randomly selected from the remaining 474 frequencies in the group. This process continues until all 475 frequencies are chosen for the set. For selection of a random frequency, the frequencies remaining within the group are always treated as equally likely.



Report No.: T200205W01-RP1

## 4. Calibration Setup and DFS Test Setup Configuration

### 4.1 Radiated Test Setup Configuration

The EUT is a U-NII Device operating in Master mode. The radar test signals are injected into the Master Device.

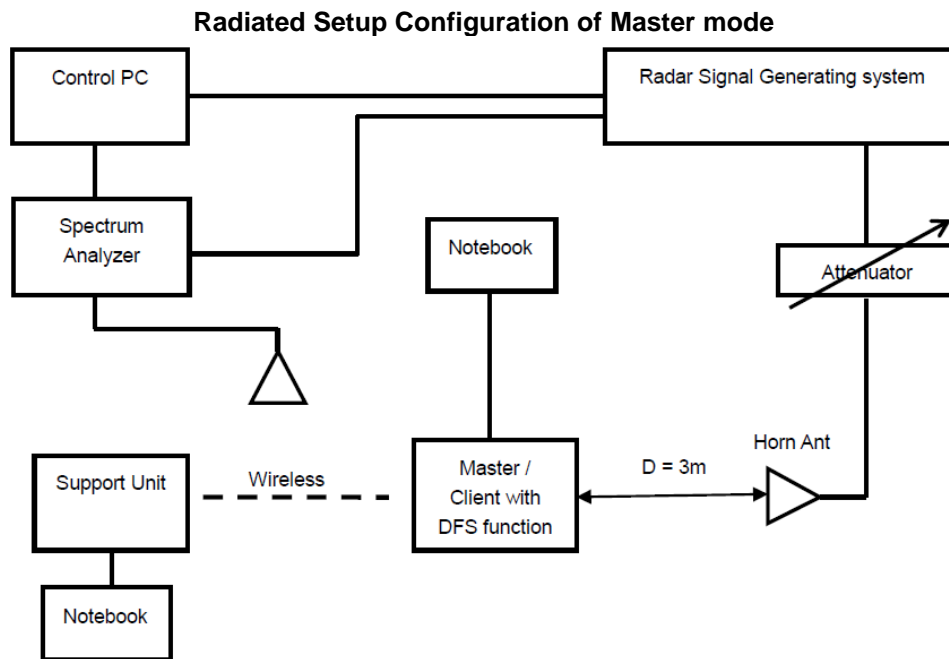

### Channel Loading

System testing will be performed with channel-loading using means appropriate to the data types that are used by the unlicensed device. The following requirements apply:

<input type="checkbox"/>	(a) The data file must be of a type that is typical for the device (i.e., MPEG-2, MPEG-4, WAV, MP3, MP4, AVI, etc.) and must generally be transmitting in a streaming mode.
<input type="checkbox"/>	(b) Software to ping the client is permitted to simulate data transfer but must have random ping intervals.
<input checked="" type="checkbox"/>	(c) Timing plots are required with calculations demonstrating a minimum channel loading of approximately 17% or greater. For example, channel loading can be estimated by setting the spectrum analyzer for zero span and approximate the Time On/ (Time On + Off Time). This can be done with any appropriate channel BW and modulation type.
<input type="checkbox"/>	(d) Unicast or Multicast protocols are preferable but other protocols may be used. The appropriate protocol used must be described in the test procedures.

Report No.: T200205W01-RP1

## 4.2 Calibration of Radar Waveform

The radar signal was the same as transmitted channels, and injected into the antenna of AP (master) or Client Device with Radar Detection, measured the channel closing transmission time and channel move time.

### Radiated setup configuration of Calibration of DFS Detection Threshold Level

The calibrated Radiated detection threshold level is set to -64dBm. The tested level is lower than required level hence it provides margin to the limit.

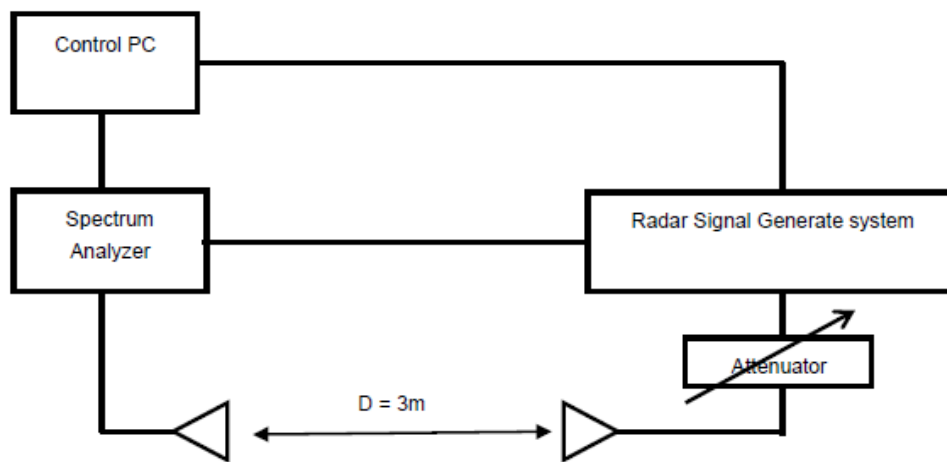

Report No.: T200205W01-RP1

## 5. DFS Tset Result

### 5.1 Radar Waveform Calibration Result

< Channel Bandwidth 20MHz / 5300MHz >

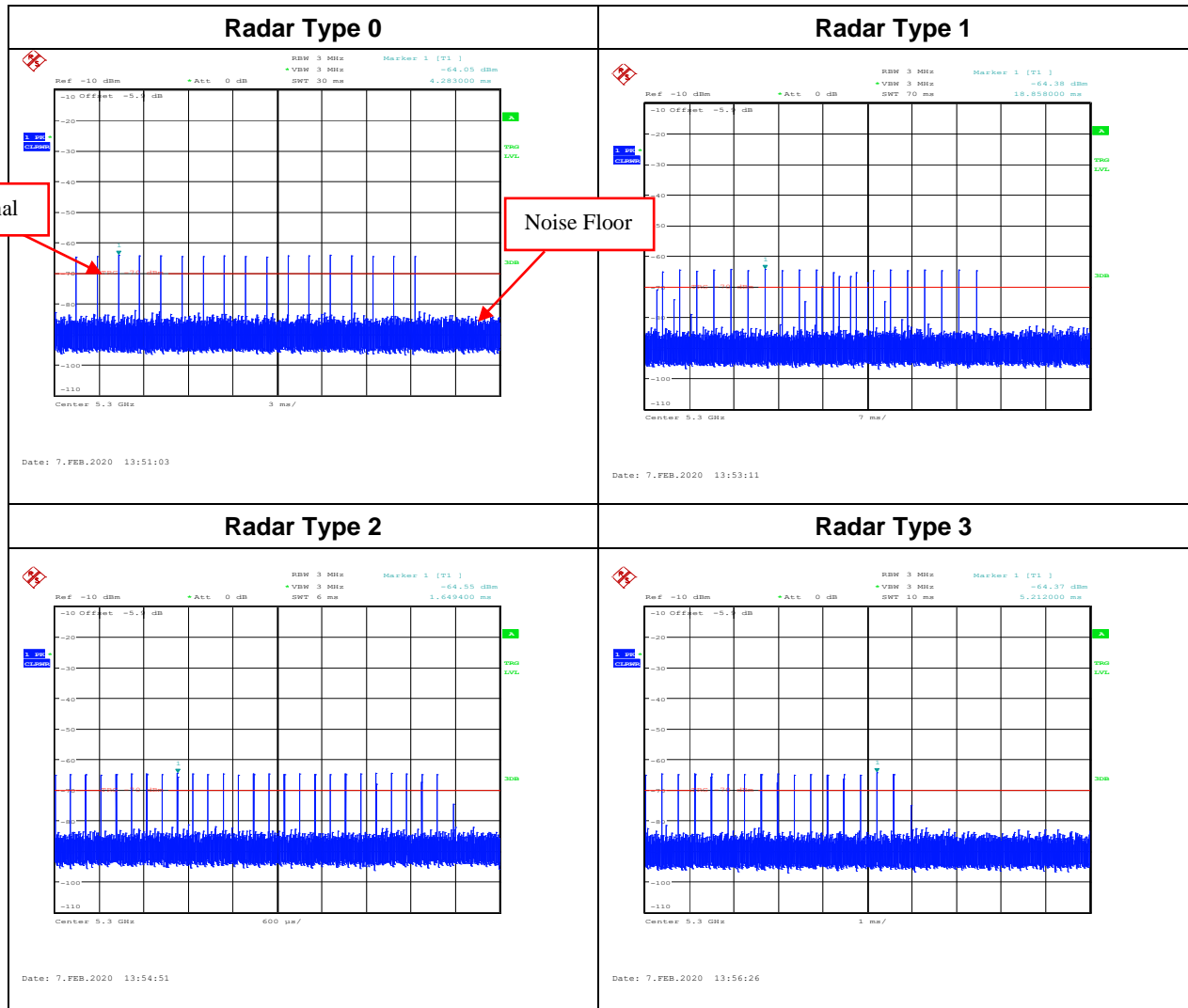

Report No.: T200205W01-RP1

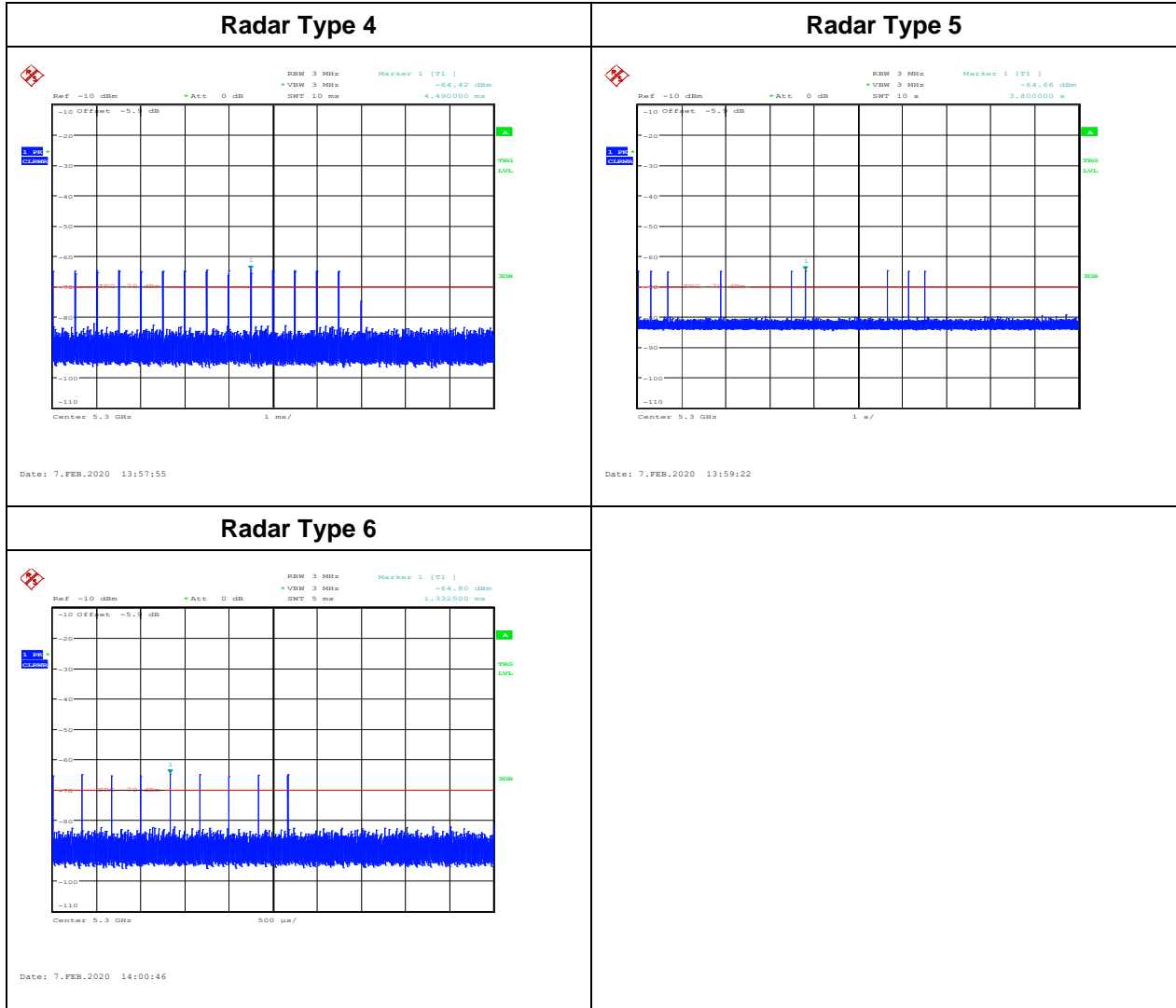

Report No.: T200205W01-RP1

< Channel Bandwidth 40MHz / 5310MHz >

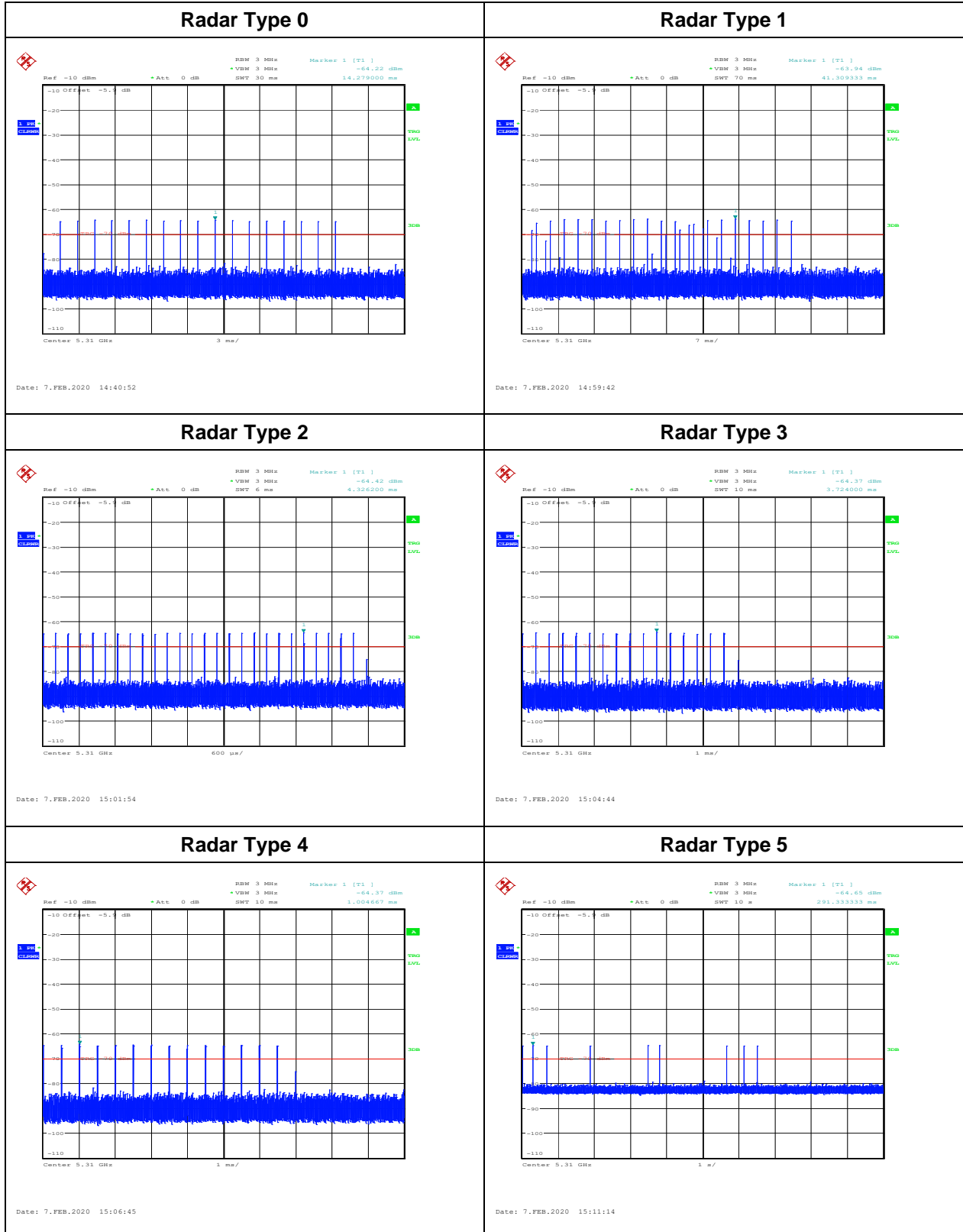



Report No.: T200205W01-RP1

Page: 22 / 58  
Rev.: 00

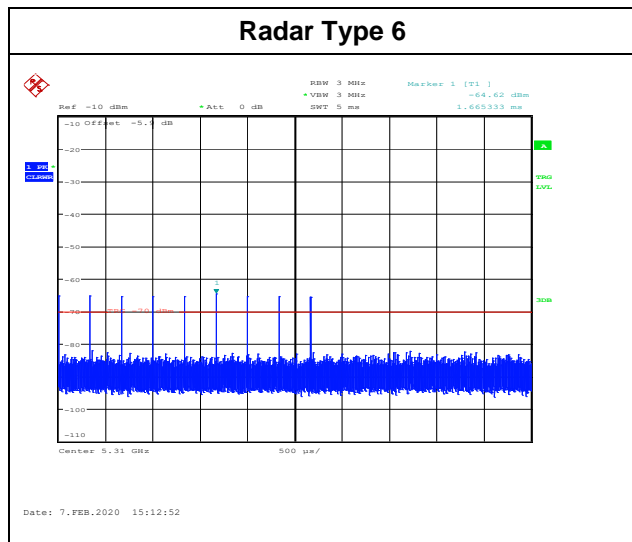

Report No.: T200205W01-RP1

< Channel Bandwidth 80MHz / 5290MHz >

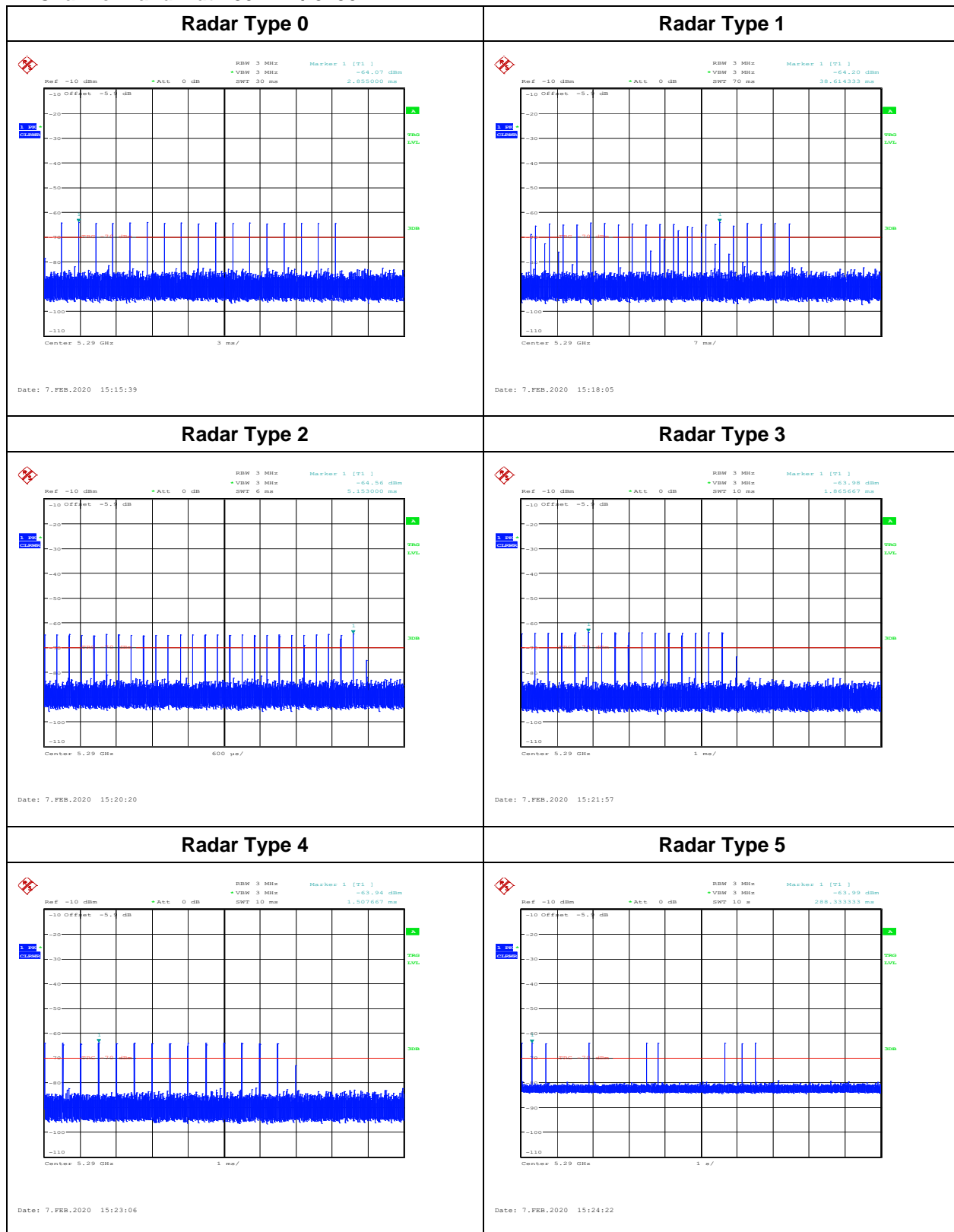

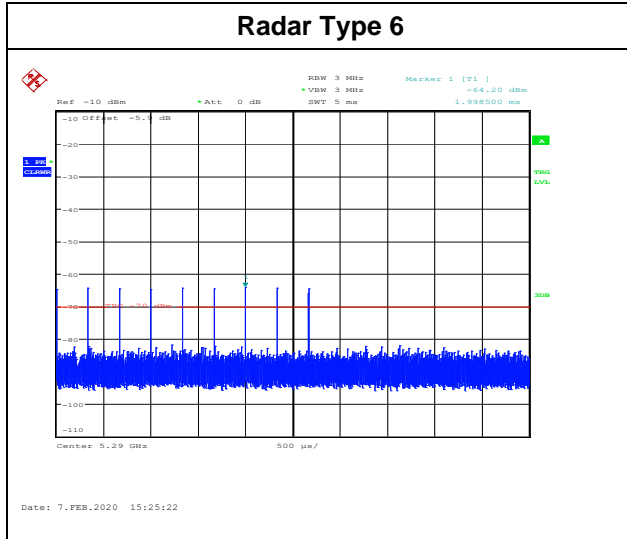



Report No.: T200205W01-RP1

< Channel Bandwidth 20MHz / 5500MHz >

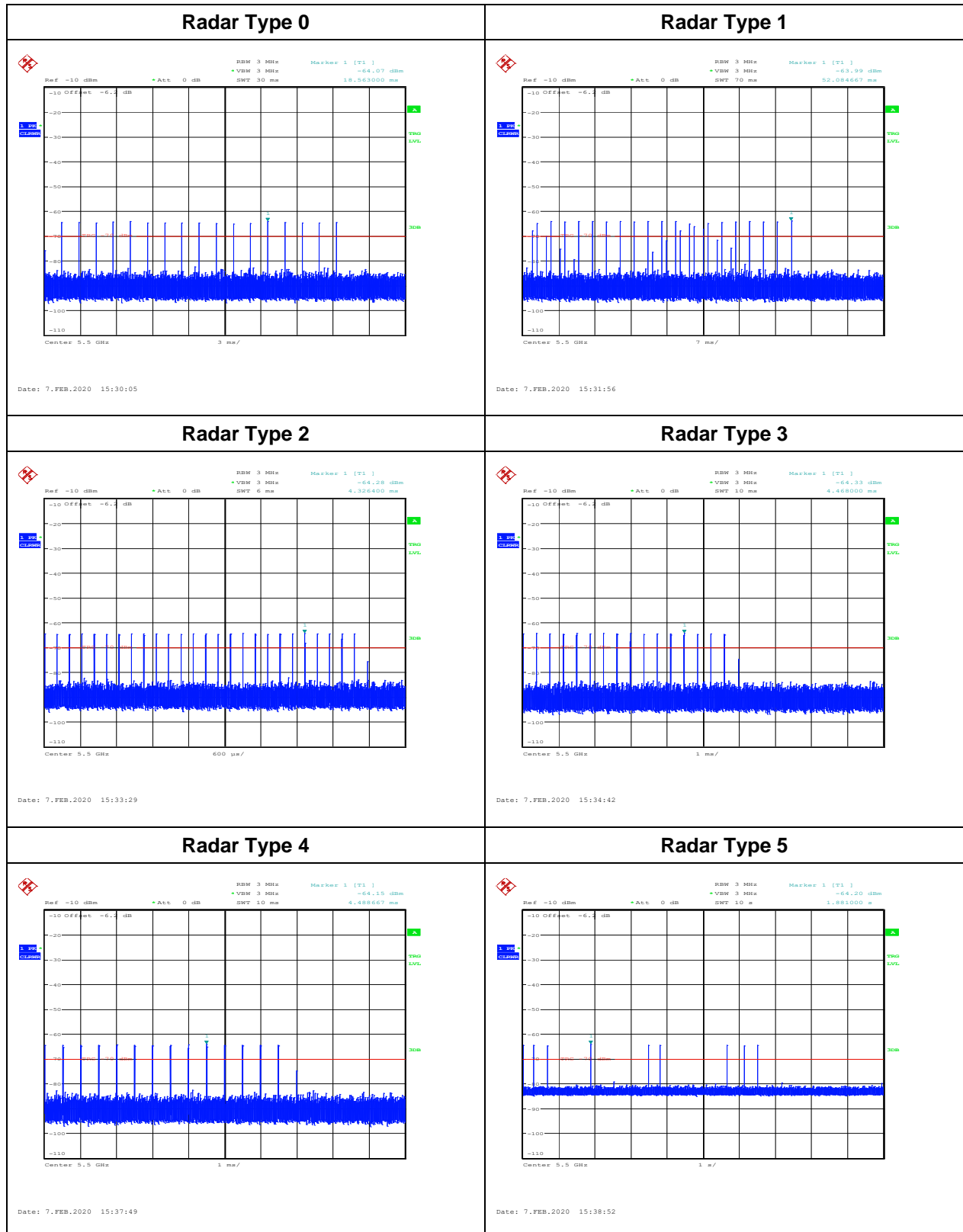



Report No.: T200205W01-RP1

Page: 26 / 58  
Rev.: 00

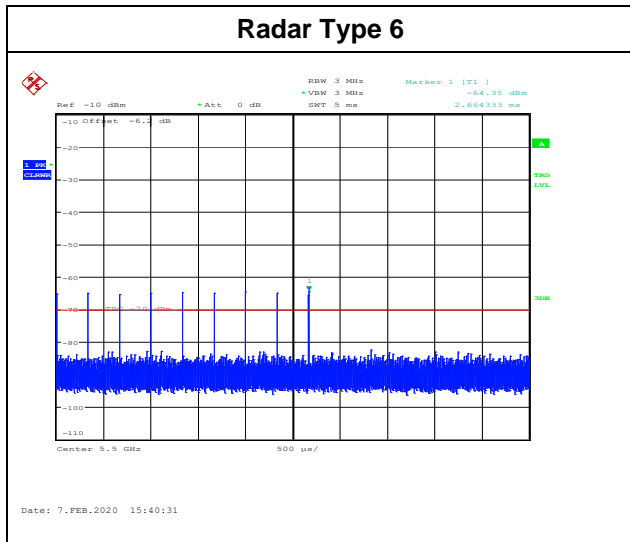

Report No.: T200205W01-RP1

< Channel Bandwidth 40MHz / 5510MHz >

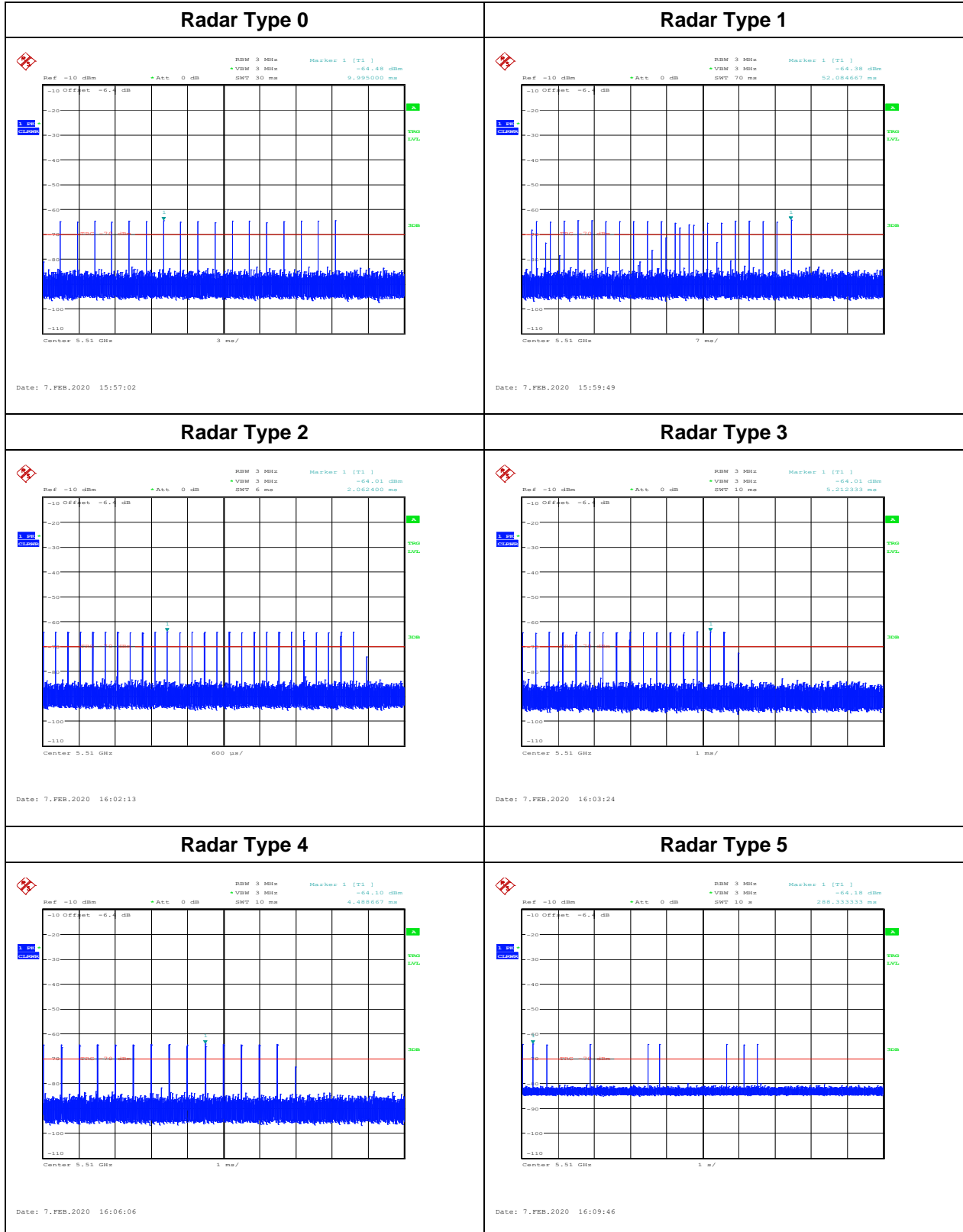



Report No.: T200205W01-RP1

Page: 28 / 58  
Rev.: 00

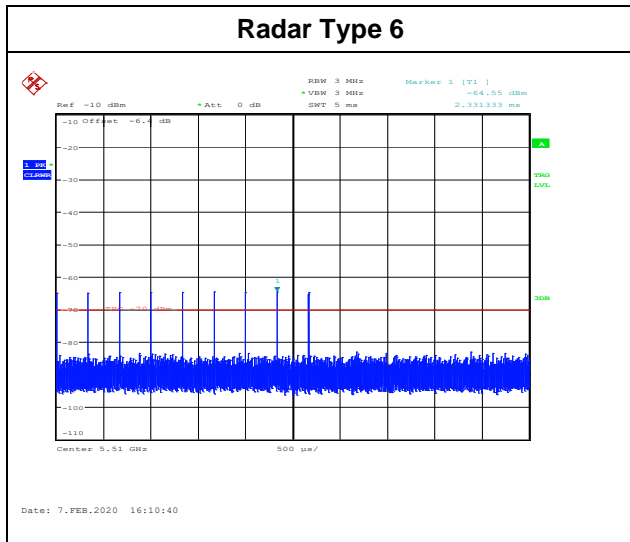

Report No.: T200205W01-RP1

< Channel Bandwidth 80MHz / 5530MHz >

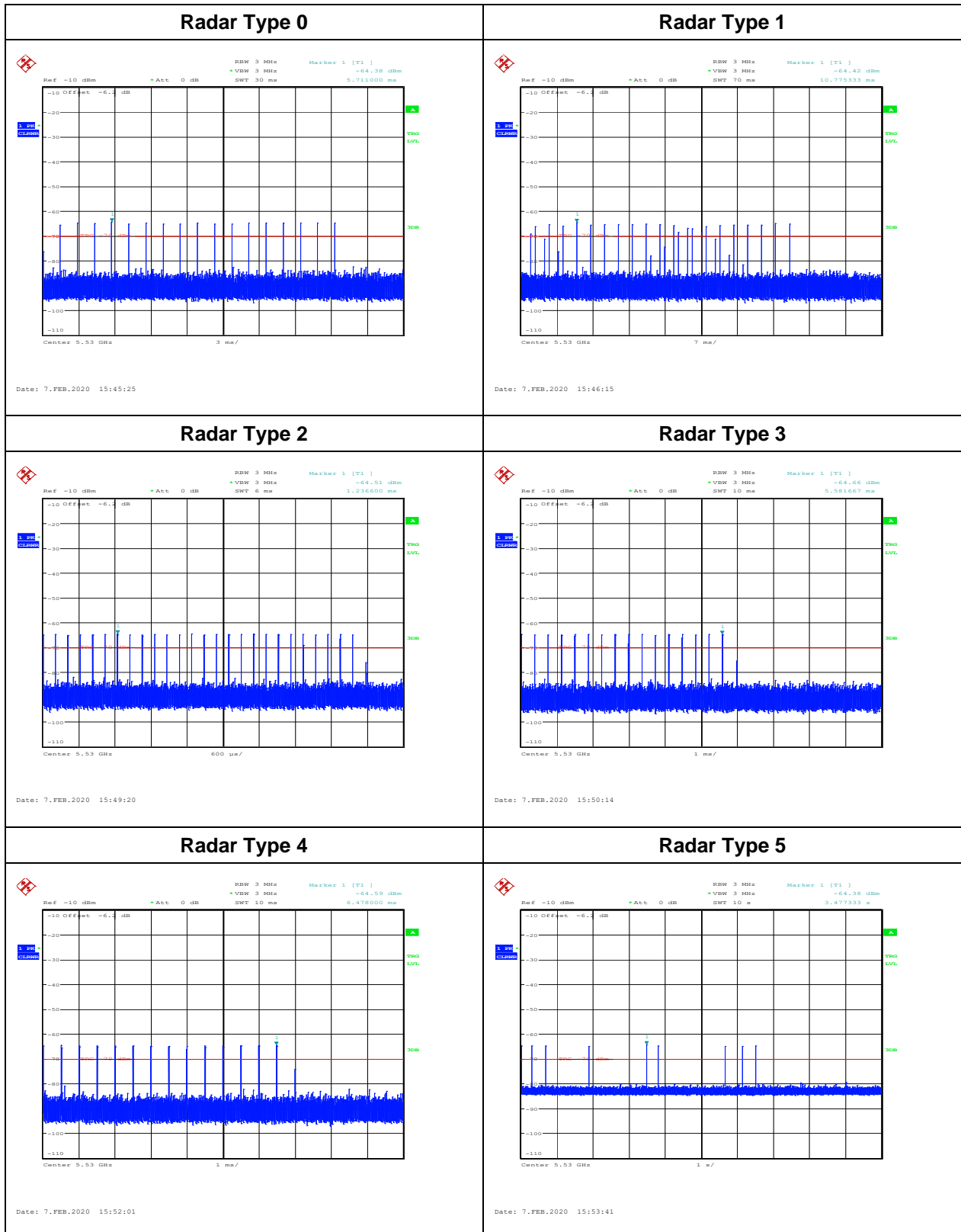

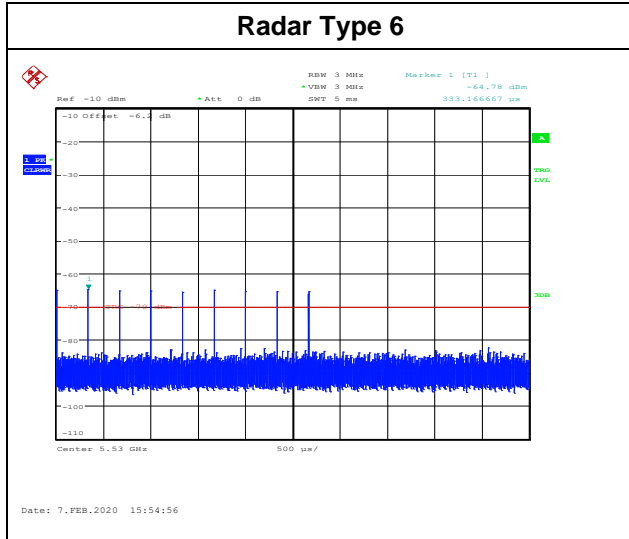

Report No.: T200205W01-RP1

## 5.2 U-NII Detection Bandwidth (7.8.1)

### 5.2.1 Limit of U-NII Detection Bandwidth

The U-NII Detection Bandwidth shall contain minimum 100% of the 99% power bandwidth. During the U-NII Detection Bandwidth detection test, radar type 0 is used and for each frequency step the minimum percentage of detection is 90%. Measurements are performed with no data traffic.

### 5.2.2 Test Procedure

1. Adjust the equipment to produce a single burst of the Short Pulse Radar Type 0 at the center frequency of the EUT Operating Channel at the specified DFS Detection Threshold level.
2. Set the EUT up as a standalone device (no associated Client or Master, as appropriate) and no traffic. Frame based systems will be set to a talk/listen ratio reflecting the worst case (maximum) that is user configurable during this test.
3. Generate a single radar burst, and note the response of the EUT. Repeat for a minimum of 10 trials. The EUT must detect the Radar Waveform using the specified U-NII Detection Bandwidth criterion.
4. Starting at the center frequency of the EUT operating Channel, increase the radar frequency in 5 MHz steps, repeating the above test sequence, until the detection rate falls below the U-NII Detection Bandwidth criterion specified in report Table 4. Repeat this measurement in 1MHz steps at frequencies 5 MHz below where the detection rate begins to fall. Record the highest frequency (denote as  $F_H$ ) at which detection is greater than or equal to the U-NII Detection Bandwidth criterion. Recording the detection rate at frequencies above  $F_H$  is not required to demonstrate compliance.
5. Starting at the center frequency of the EUT operating Channel, decrease the radar frequency in 5 MHz steps, repeating the above test sequence, until the detection rate falls below the U-NII Detection Bandwidth criterion specified in report Table 4. Repeat this measurement in 1MHz steps at frequencies 5 MHz above where the detection rate begins to fall. Record the lowest frequency (denote as  $F_L$ ) at which detection is greater than or equal to the U-NII Detection Bandwidth criterion. Recording the detection rate at frequencies below  $F_L$  is not required to demonstrate compliance.
6. The U-NII Detection Bandwidth is calculated as follows:  
$$\text{U-NII Detection Bandwidth} = F_H - F_L$$

### 5.2.3 Result of U-NII Detection Bandwidth

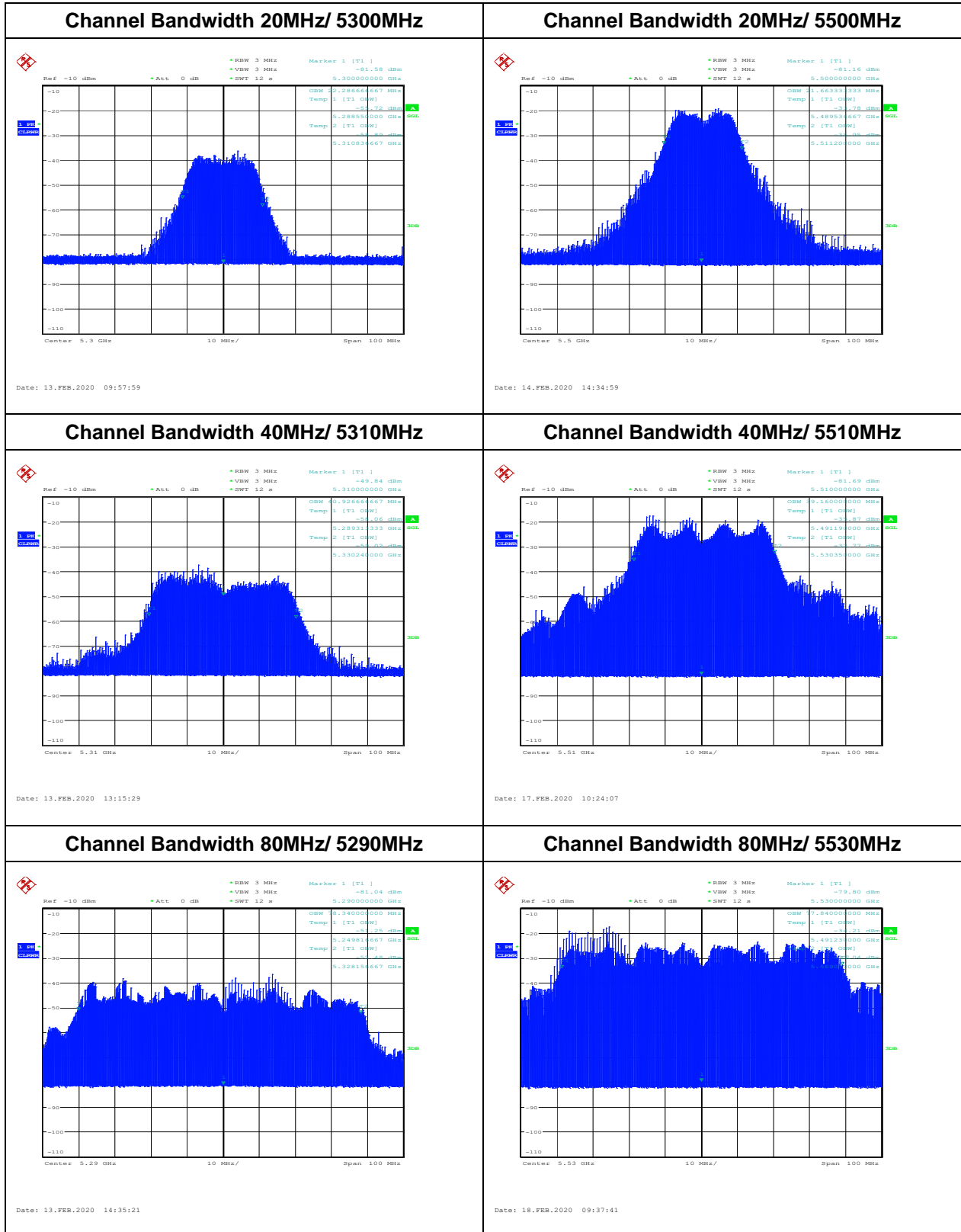



Report No.: T200205W01-RP1

**Channel Bandwidth 20MHz/ 5300MHz**

CH60_5300MHz											Radar type 0	
Frequency (MHz)	Trial Number (Detection = Y, No Detection = N)										Detection Rate (%)	F <sub>H</sub> /F <sub>L</sub>
	1	2	3	4	5	6	7	8	9	10		
5290	Y	Y	Y	Y	Y	Y	Y	Y	Y	Y	100%	FL
5295	Y	Y	Y	Y	Y	Y	Y	Y	Y	Y	100%	
5300	Y	Y	Y	Y	Y	Y	Y	Y	Y	Y	100%	
5305	Y	Y	Y	Y	Y	Y	Y	Y	Y	Y	100%	
5310	Y	Y	Y	Y	Y	Y	Y	Y	Y	Y	100%	FH
Detection Bandwidth = FH - FL = 5310 - 5290 = 20MHz												
EUT 99% Bandwidth = 19.46 MHz												

**Channel Bandwidth 20MHz/ 5500MHz**

CH100_5500MHz											Radar type 0	
Frequency (MHz)	Trial Number (Detection = Y, No Detection = N)										Detection Rate (%)	F <sub>H</sub> /F <sub>L</sub>
	1	2	3	4	5	6	7	8	9	10		
5490	Y	Y	Y	Y	Y	Y	Y	Y	Y	Y	100%	FL
5495	Y	Y	Y	Y	Y	Y	Y	Y	Y	Y	100%	
5500	Y	Y	Y	Y	Y	Y	Y	Y	Y	Y	100%	
5505	Y	Y	Y	Y	Y	Y	Y	Y	Y	Y	100%	
5510	Y	Y	Y	Y	Y	Y	Y	Y	Y	Y	100%	FH
Detection Bandwidth = FH - FL = 5515 - 5485 = 30MHz												
EUT 99% Bandwidth = 19.15 MHz												

Report No.: T200205W01-RP1

**Channel Bandwidth 40MHz/ 5310MHz**

CH62_5310MHz											Radar type 0	
Frequency (MHz)	Trial Number (Detection = Y, No Detection = N)										Detection Rate (%)	F <sub>H</sub> /F <sub>L</sub>
	1	2	3	4	5	6	7	8	9	10		
5290	Y	Y	Y	Y	Y	Y	Y	Y	Y	Y	100%	FL
5295	Y	Y	Y	Y	Y	Y	Y	Y	Y	Y	100%	
5300	Y	Y	Y	Y	Y	Y	Y	Y	Y	Y	100%	
5305	Y	Y	Y	Y	Y	Y	Y	Y	Y	Y	100%	
5310	Y	Y	Y	Y	Y	Y	Y	Y	Y	Y	100%	
5315	Y	Y	Y	Y	Y	Y	Y	Y	Y	Y	100%	
5320	Y	Y	Y	Y	Y	Y	Y	Y	Y	Y	100%	
5325	Y	Y	Y	Y	Y	Y	Y	Y	Y	Y	100%	
5330	Y	Y	Y	Y	Y	Y	Y	Y	Y	Y	100%	FH
Detection Bandwidth = FH - FL = 5330 - 5290 = 40MHz												
EUT 99% Bandwidth = 40.92MHz												

**Channel Bandwidth 40MHz/ 5510MHz**

CH102_5510MHz											Radar type 0	
Frequency (MHz)	Trial Number (Detection = Y, No Detection = N)										Detection Rate (%)	F <sub>H</sub> /F <sub>L</sub>
	1	2	3	4	5	6	7	8	9	10		
5490	Y	Y	Y	Y	Y	Y	Y	Y	Y	Y	100%	FL
5495	Y	Y	Y	Y	Y	Y	Y	Y	Y	Y	100%	
5500	Y	Y	Y	Y	Y	Y	Y	Y	Y	Y	100%	
5505	Y	Y	Y	Y	Y	Y	Y	Y	Y	Y	100%	
5510	Y	Y	Y	Y	Y	Y	Y	Y	Y	Y	100%	
5515	Y	Y	Y	Y	Y	Y	Y	Y	Y	Y	100%	
5520	Y	Y	Y	Y	Y	Y	Y	Y	Y	Y	100%	
5525	Y	Y	Y	Y	Y	Y	Y	Y	Y	Y	100%	
5530	Y	Y	Y	Y	Y	Y	Y	Y	Y	Y	100%	FH
Detection Bandwidth = FH - FL = 5530 - 5490 = 40MHz												
EUT 99% Bandwidth = 39.16 MHz												

**Channel Bandwidth 80MHz/ 5290MHz**

CH106_5290MHz											Radar type 0	
Frequency (MHz)	Trial Number (Detection = Y, No Detection = N)										Detection Rate (%)	F <sub>H</sub> /F <sub>L</sub>
	1	2	3	4	5	6	7	8	9	10		
5250	Y	Y	Y	Y	Y	Y	Y	Y	Y	Y	100%	FL
5255	Y	Y	Y	Y	Y	Y	Y	Y	Y	Y	100%	
5260	Y	Y	Y	Y	Y	Y	Y	Y	Y	Y	100%	
5265	Y	Y	Y	Y	Y	Y	Y	Y	Y	Y	100%	
5270	Y	Y	Y	Y	Y	Y	Y	Y	Y	Y	100%	
5275	Y	Y	Y	Y	Y	Y	Y	Y	Y	Y	100%	
5280	Y	Y	Y	Y	Y	Y	Y	Y	Y	Y	100%	
5285	Y	Y	Y	Y	Y	Y	Y	Y	Y	Y	100%	
5290	Y	Y	Y	Y	Y	Y	Y	Y	Y	Y	100%	
5295	Y	Y	Y	Y	Y	Y	Y	Y	Y	Y	100%	
5300	Y	Y	Y	Y	Y	Y	Y	Y	Y	Y	100%	
5305	Y	Y	Y	Y	Y	Y	Y	Y	Y	Y	100%	
5310	Y	Y	Y	Y	Y	Y	Y	Y	Y	Y	100%	
5315	Y	Y	Y	Y	Y	Y	Y	Y	Y	Y	100%	
5320	Y	Y	Y	Y	Y	Y	Y	Y	Y	Y	100%	
5325	Y	Y	Y	Y	Y	Y	Y	Y	Y	Y	100%	
5330	Y	Y	Y	Y	Y	Y	Y	Y	Y	Y	100%	FH
Detection Bandwidth = FH - FL = 5330 - 5250 = 80MHz												
EUT 99% Bandwidth = 78.34MHz												

Report No.: T200205W01-RP1

**Channel Bandwidth 80MHz/ 5530MHz**

CH106_5530MHz											Radar type 0	
Frequency (MHz)	Trial Number (Detection = Y, No Detection = N)										Detection Rate (%)	F <sub>H</sub> /F <sub>L</sub>
	1	2	3	4	5	6	7	8	9	10		
5490	Y	Y	Y	Y	Y	Y	Y	Y	Y	Y	100%	FL
5495	Y	Y	Y	Y	Y	Y	Y	Y	Y	Y	100%	
5500	Y	Y	Y	Y	Y	Y	Y	Y	Y	Y	100%	
5505	Y	Y	Y	Y	Y	Y	Y	Y	Y	Y	100%	
5510	Y	Y	Y	Y	Y	Y	Y	Y	Y	Y	100%	
5515	Y	Y	Y	Y	Y	Y	Y	Y	Y	Y	100%	
5520	Y	Y	Y	Y	Y	Y	Y	Y	Y	Y	100%	
5525	Y	Y	Y	Y	Y	Y	Y	Y	Y	Y	100%	
5530	Y	Y	Y	Y	Y	Y	Y	Y	Y	Y	100%	
5535	Y	Y	Y	Y	Y	Y	Y	Y	Y	Y	100%	
5540	Y	Y	Y	Y	Y	Y	Y	Y	Y	Y	100%	
5545	Y	Y	Y	Y	Y	Y	Y	Y	Y	Y	100%	
5550	Y	Y	Y	Y	Y	Y	Y	Y	Y	Y	100%	
5555	Y	Y	Y	Y	Y	Y	Y	Y	Y	Y	100%	
5560	Y	Y	Y	Y	Y	Y	Y	Y	Y	Y	100%	
5565	Y	Y	Y	Y	Y	Y	Y	Y	Y	Y	100%	
5570	Y	Y	Y	Y	Y	Y	Y	Y	Y	Y	100%	FH
Detection Bandwidth = FH - FL = 5570 - 5490 = 80MHz												
EUT 99% Bandwidth = 77.84MHz												

## 5.3 Channel Availability Check (7.8.2)

### 5.3.1 Limit of Channel Availability Check

The Initial Channel Availability Check Time tests that the EUT does not emit beacon, control, or data signals on the test Channel until the power-up sequence has been completed and the U-NII device checks for Radar Waveforms for **one minute** on the test Channel.

### 5.3.2 Test Procedure

#### 5.3.2.1 Initial Channel Availability Check Time

This test does not use any radar waveforms and only needs to be performed one time.

1. The U-NII devices will be powered on and be instructed to operate on the appropriate U-NII Channel that must incorporate DFS functions. At the same time the EUT is powered on, the spectrum analyzer will be set to zero span modes with a 3 MHz RBW and 3 MHz VBW on the Channel occupied by the radar ( $Ch_r$ ) with a 2.5 minute sweep time. The spectrum analyzer's sweep will be started at the same time power is applied to the U-NII device.
2. The EUT should not transmit any beacon or data transmissions until at least 1 minute after the completion of the power-on cycle

#### 5.3.2.2 Radar Burst at the Beginning of the Channel Availability Check Time

The steps below define the procedure to verify successful radar detection on the test Channel during a period equal to the Channel Availability Check Time and avoidance of operation on that Channel when a radar Burst with a level equal to the DFS Detection Threshold + 1 dB occurs at the beginning of the Channel Availability Check Time. This is illustrated in Figure 15.

1. The Radar Waveform generator and EUT are connected using the applicable test setup and the power of the EUT is switched off.
2. The EUT is powered on at  $T_0$ .  $T_1$  denotes the instant when the EUT has completed its power-up sequence ( $T_{power\_up}$ ). The Channel Availability Check Time commences on  $Ch_r$  at instant  $T_1$  and will end no sooner than  $T_1 + Tch\_avail\_check$ .
3. A single Burst of one of the Short Pulse Radar Types 0-4 will commence within a 6 second window starting at  $T_1$ . An additional 1 dB is added to the radar test signal to ensure it is at or above the DFS Detection Threshold, accounting for equipment variations/errors.
4. Visual indication or measured results on the EUT of successful detection of the radar Burst will be recorded and reported. Observation of  $Ch_r$  for EUT emissions will continue for 2.5 minutes after the radar Burst has been generated.
5. Verify that during the 2.5 minute measurement window no EUT transmissions occurred on  $Ch_r$ . The Channel Availability Check results will be recorded.

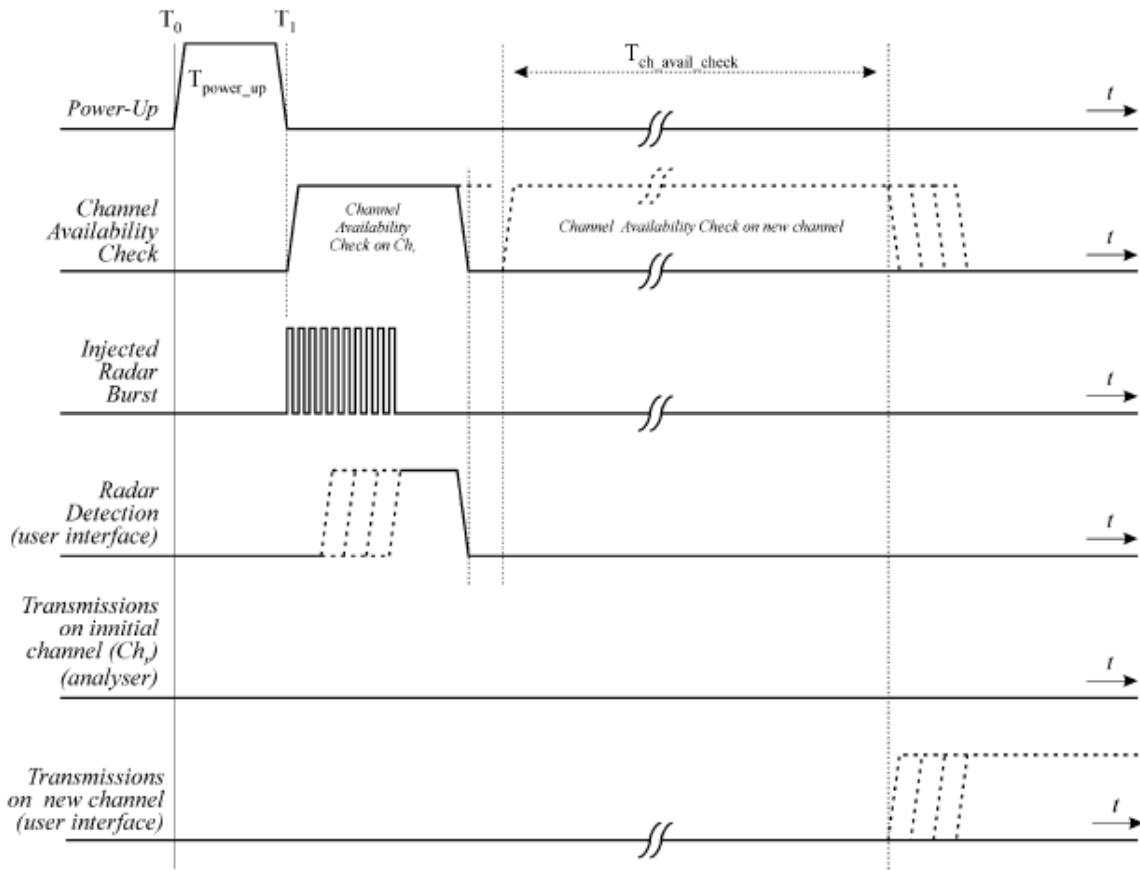

Figure 15: Example of timing for radar testing at the beginning of the Channel Availability Check Time

### 5.3.2.3 Radar Burst at the End of the Channel Availability Check Time

The steps below define the procedure to verify successful radar detection on the test Channel during a period equal to the Channel Availability Check Time and avoidance of operation on that Channel when a radar Burst with a level equal to the DFS Detection Threshold + 1dB occurs at the end of the Channel Availability Check Time. This is illustrated in Figure 16.

1. The Radar Waveform generator and EUT are connected using the applicable test setup and the power of the EUT is switched off.
2. The EUT is powered on at  $T_0$ .  $T_1$  denotes the instant when the EUT has completed its power-up sequence ( $T_{power\_up}$ ). The Channel Availability Check Time commences on Chr at instant  $T_1$  and will end no sooner than  $T_1 + T_{ch\_avail\_check}$ .
3. A single Burst of one of the Short Pulse Radar Types 1-4 will commence within a 6 second window starting at  $T_1 + 54$  seconds. An additional 1 dB is added to the radar test signal to ensure it is at or above the DFS Detection Threshold, accounting for equipment variations/errors.
4. Visual indication or measured results on the EUT of successful detection of the radar Burst will be recorded and reported. Observation of Chr for EUT emissions will continue for 2.5 minutes after the radar Burst has been generated.
5. Verify that during the 2.5 minute measurement window no EUT transmissions occurred on Chr. The Channel Availability Check results will be recorded.

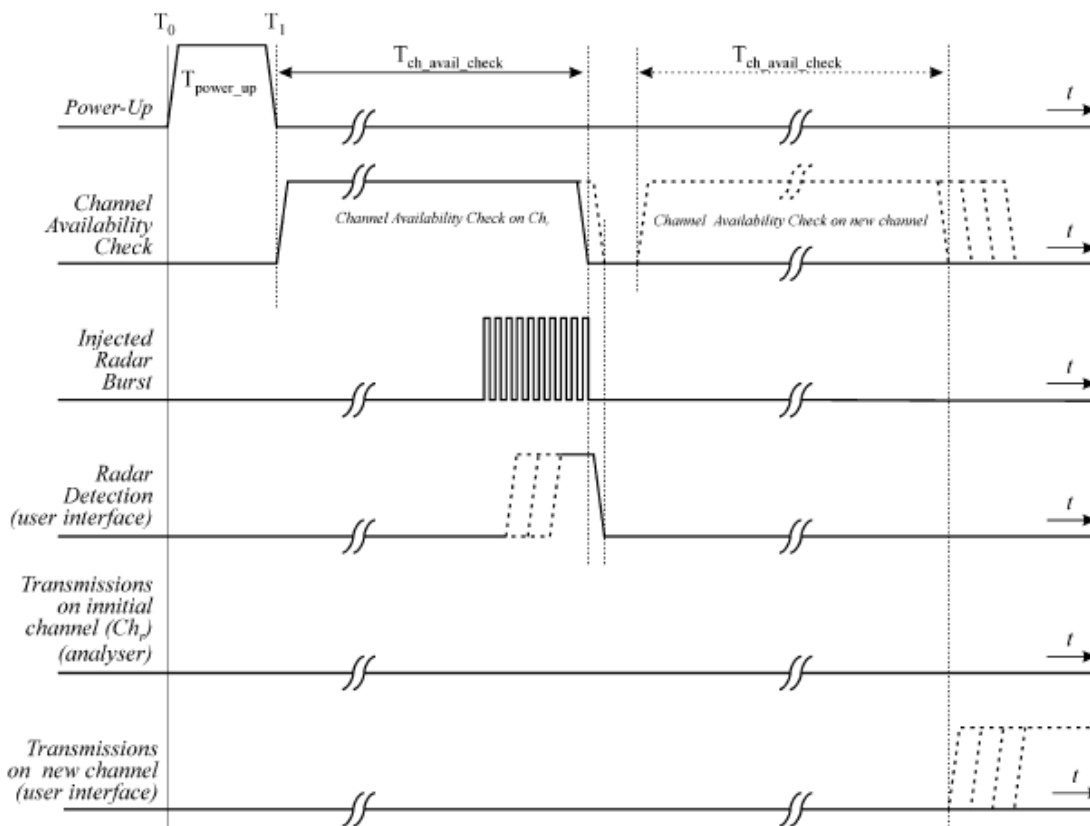
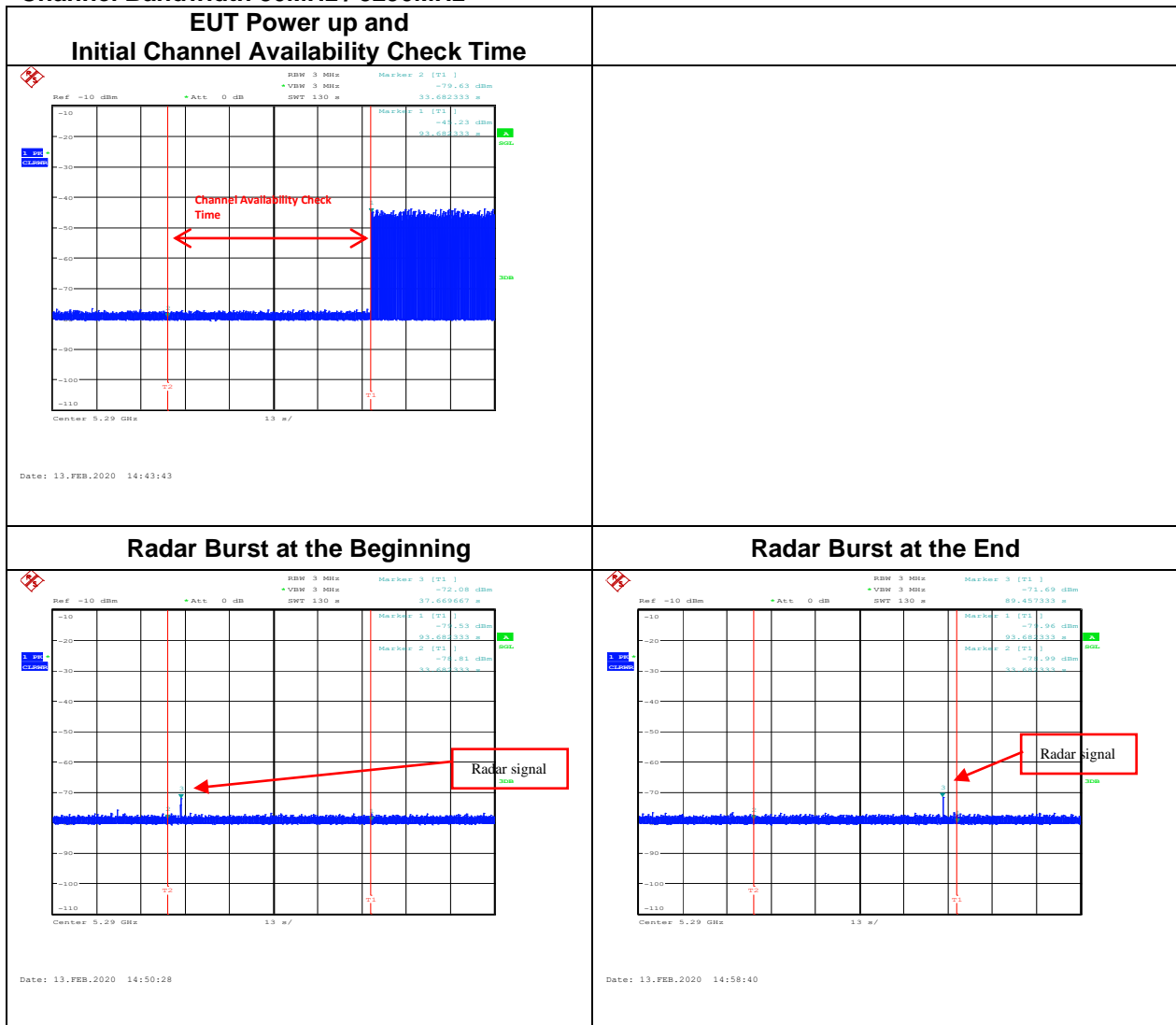

Figure 16: Example of timing for radar testing towards the end of the Channel Availability Check Time

Report No.: T200205W01-RP1

### 5.3.3 Result of Channel Availability Check

Channel Bandwidth 80MHz / 5290MHz





Report No.: T200205W01-RP1

Channel Bandwidth 80MHz / 5530MHz

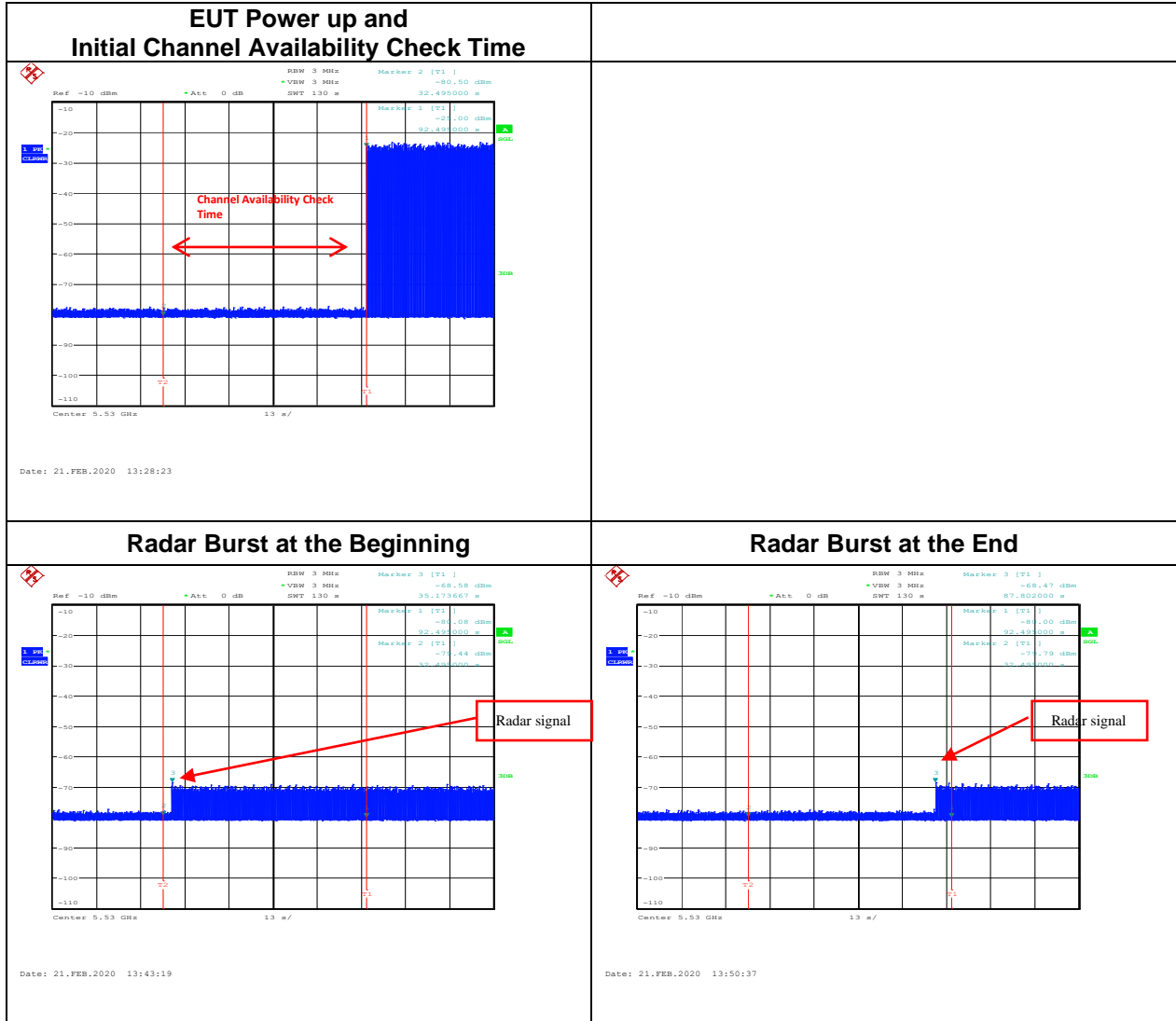

## 5.4 In-Service Monitoring: Channel Move Time, Channel Closing Transmission Time and Non-Occupancy Period (7.8.3)

### 5.4.1 Limit of In-Service Monitoring

The EUT has In-Service Monitoring function to continuously monitor the radar signals, If radar is detected, it must leave the channel (Shutdown). The Channel Move Time to cease all transmissions on the current Channel upon detection of a Radar Waveform above the DFS Detection Threshold within **10 sec**.

The total duration of Channel Closing Transmission Time is comprised of 200 milliseconds starting at the beginning of the Channel Move Time plus any additional intermittent control signals required facilitating Channel changes (an aggregate of 60 milliseconds) during the remainder of the 10 second period. The aggregate duration of control signals will not count quiet periods in between transmissions.

Non-Occupancy Period time is **30 minute** during which a Channel will not be utilized after a Radar Waveform is detected on that Channel

Report No.: T200205W01-RP1

### 5.4.2 Test Procedures

1. One frequency will be chosen from the Operating Channels of the EUT within the 5250-5350 MHz or 5470-5725 MHz bands. For 802.11 devices, the test frequency must contain control signals. This can be verified by disabling channel loading and monitoring the spectrum analyzer. If no control signals are detected, another frequency must be selected within the emission bandwidth where control signals are detected.
2. In case the EUT is a Master Device, a U-NII device operating as a Client Device will be used and it is assumed that the Client will associate with the EUT (Master). For radiated tests, the emissions of the Radar Waveform generator will be directed towards the Master Device. If the Master Device has antenna gain, the main beam of the antenna will be directed toward the radar emitter. Vertical polarization is used for testing.
3. The TCP protocol unicast data stream was generated by the LanTest software with at least 17% activity ratio over any 100ms period.
4. Timing plots are reported with calculations demonstrating a minimum channel loading of approximately 17% or greater. For example, channel loading can be estimated by setting the spectrum analyzer for zero span and approximate the Time On/ (Time On + Off Time).
5. At time  $T_0$  the Radar Waveform generator sends a Burst of pulses for one of the Radar Type 0 in Table 5 at levels defined in Table 3, on the Operating Channel. An additional 1 dB is added to the radar test signal to ensure it is at or above the DFS Detection Threshold, accounting for equipment variations/errors.
6. Observe the transmissions of the EUT at the end of the radar Burst on the Operating Channel for duration greater than 10 seconds. Measure and record the transmissions from the EUT during the observation time (Channel Move Time). Measure and record the Channel Move Time and Channel Closing Transmission Time if radar detection occurs.
7. When operating as a Master Device, monitor the UUT for more than 30 minutes following instant  $T_2$  to verify that the EUT does not resume any transmissions on this Channel. Perform this test once and record the measurement result.

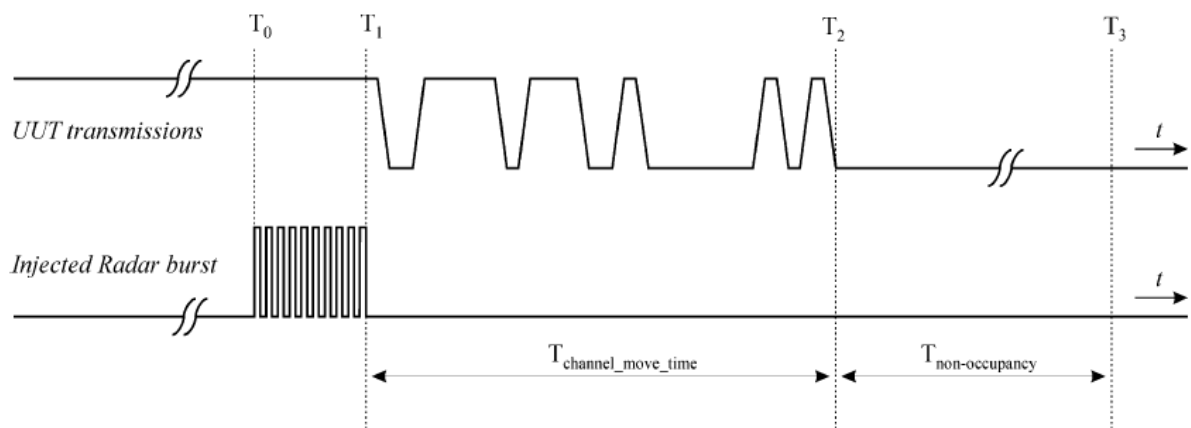

Report No.: T200205W01-RP1

### 5.4.3 Result of Channel Move Time, Channel Closing Transmission Time and Non-Occupancy Period

#### Data Traffic Channel Loading and Noise Floor Plots

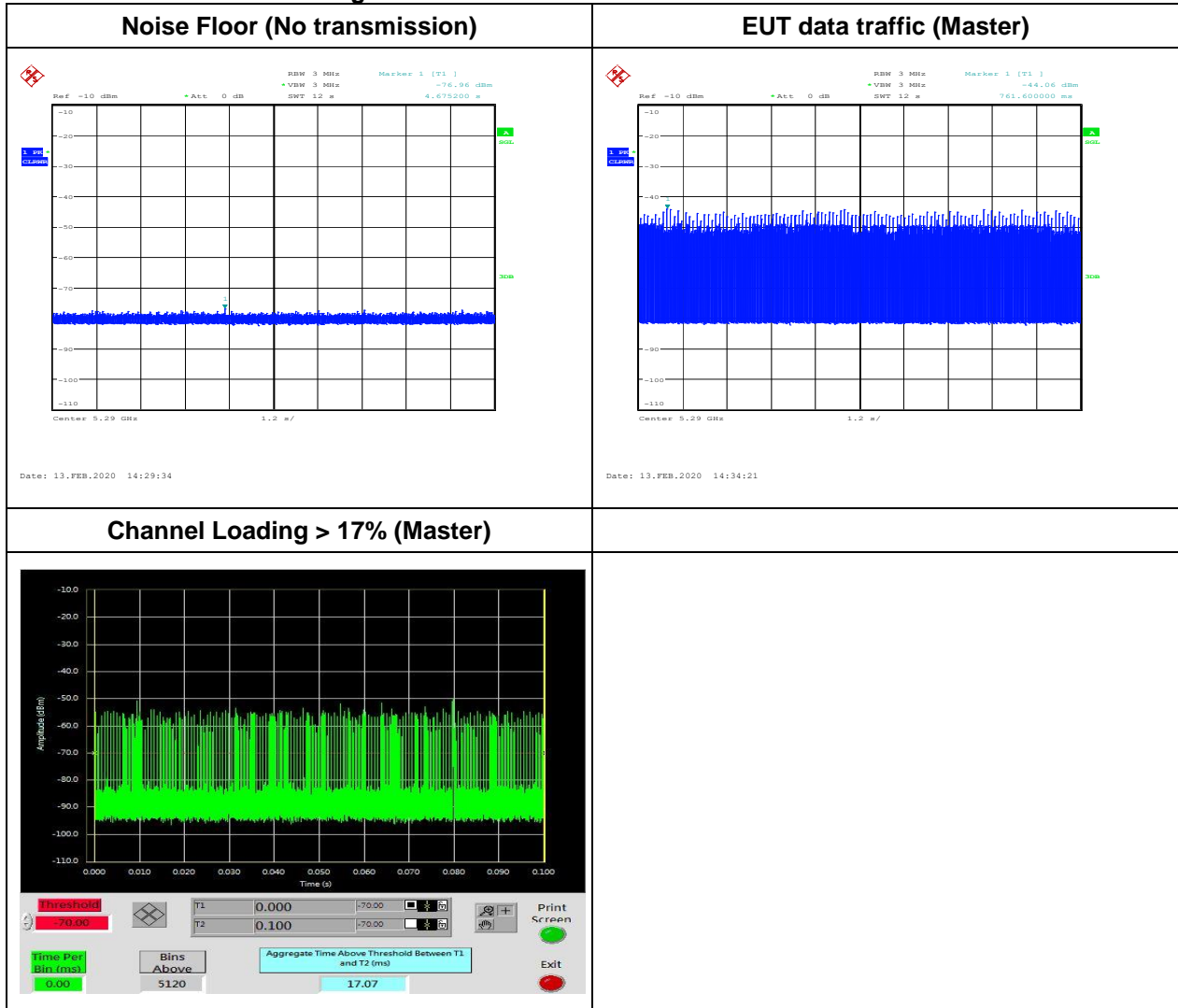

Report No.: T200205W01-RP1

**Channel Bandwidth 80MHz / 5290MHz**

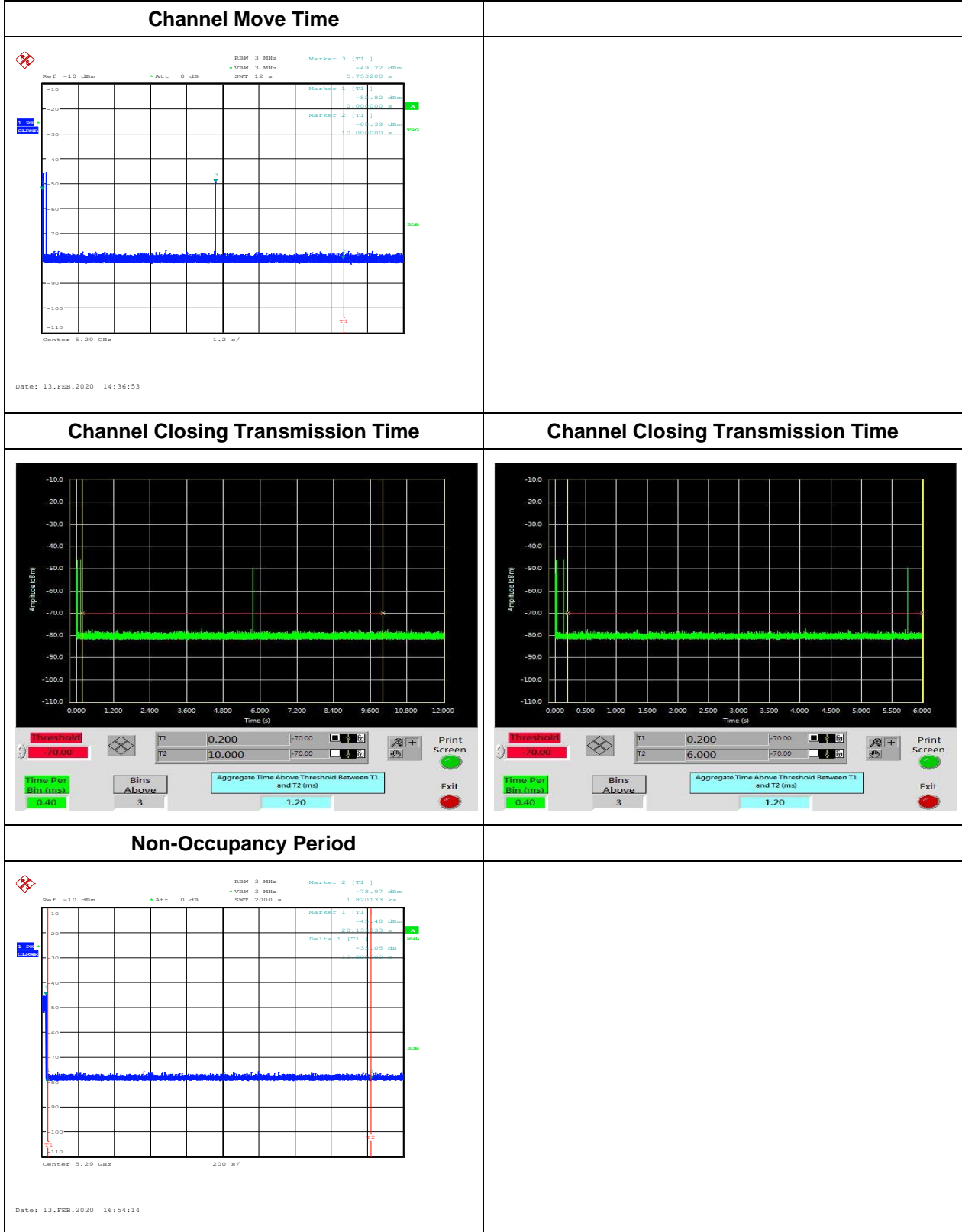

Report No.: T200205W01-RP1

Channel Bandwidth 80MHz / 5530MHz

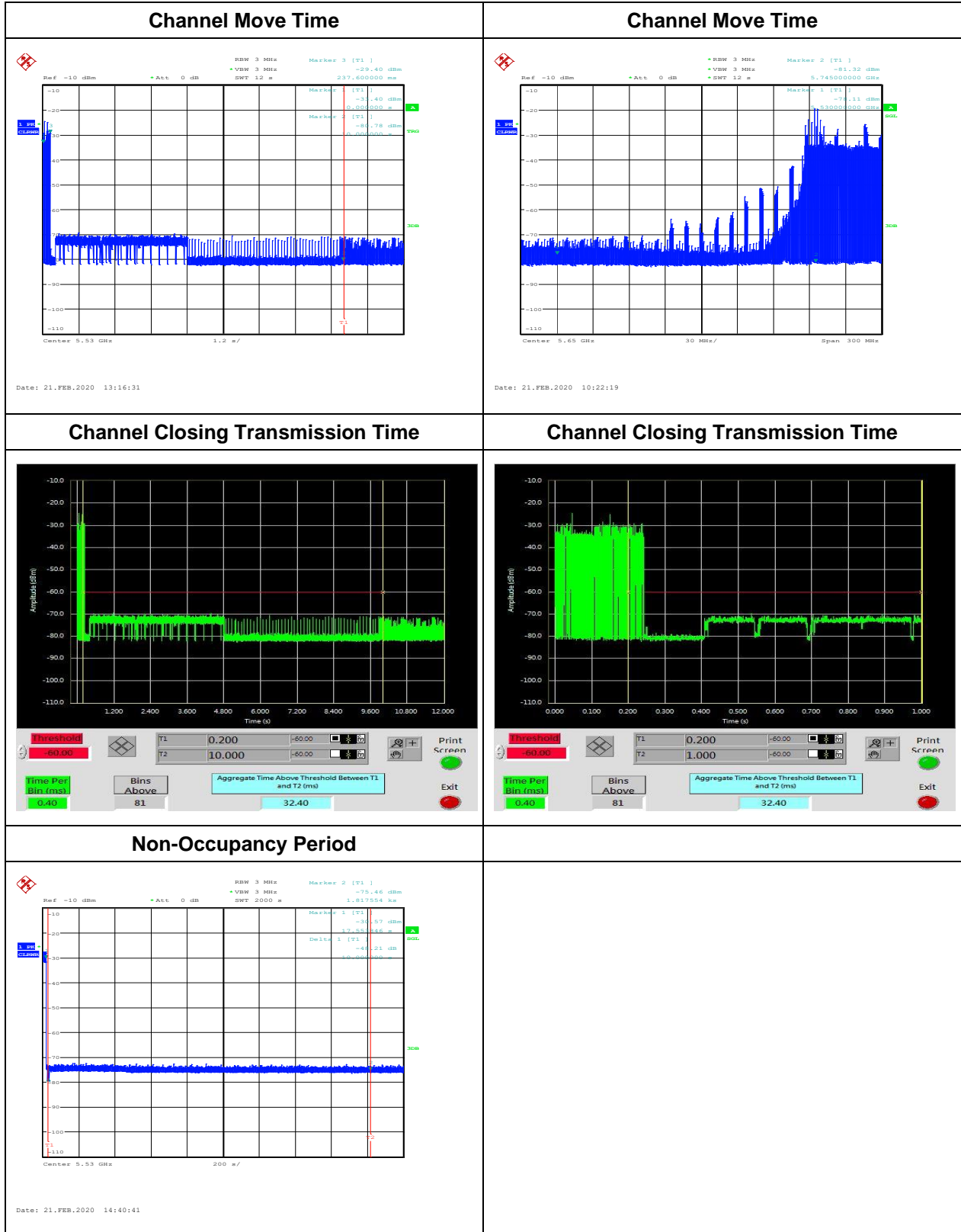

## 5.5 Statistical Performance Check (7.8.4)

### 5.5.1 Limit of Statistical Performance Check

#### **Short Pulse Radar Test**

Once the performance requirements check is complete, statistical data will be gathered, to determine the ability of the device to detect the radar test waveforms (Short Pulse Radar Types 1-4) found in Table 5. The device can utilize a test mode to demonstrate when detection occurs to prevent the need to reset the device between trials. The percentage of successful detection is calculated by:

$$\frac{\text{TotalWaveformDetections}}{\text{TotalWaveformTrials}} \times 100 = \text{Percentage of Successful Detection Radar Waveform } N = P_d N$$

In addition an aggregate minimum percentage of successful detection across all Short Pulse Radar Types 1-4 is required and is calculated as follows:

$$\frac{P_d 1 + P_d 2 + P_d 3 + P_d 4}{4}$$

The minimum number of trails, minimum percentage of successful detection and the aggregate minimum percentage of successful detection are found in Table 5.

Report No.: T200205W01-RP1

**Long Pulse Radar Test**

Statistical data will be gathered to determine the ability of the device to detect the Long Pulse Radar Type 5 found in Table 6. The device can utilize a test mode to demonstrate when detection occurs to prevent the need to reset the device between trials.

Three subsets of trials will be performed with a minimum of ten trials per subset. The subset of trials differ in where the Long Pulse Type 5 Signal is tuned in frequency:

(a) The Channel center frequency.

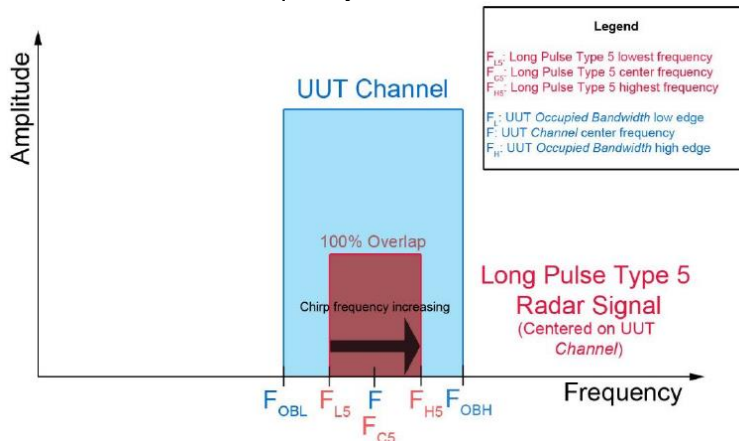

(b) Tuned frequencies such that 90% of the Long Pulse Type 5 frequency modulation is within the low edge of the EUT Occupied Bandwidth.

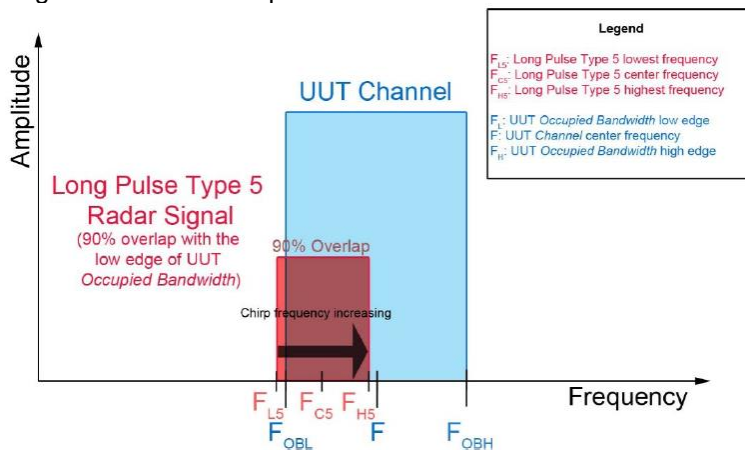



- (c) Tuned frequencies such that 90% of the Long Pulse Type 5 frequency modulation is within the high edge of the EUT Occupied Bandwidth.

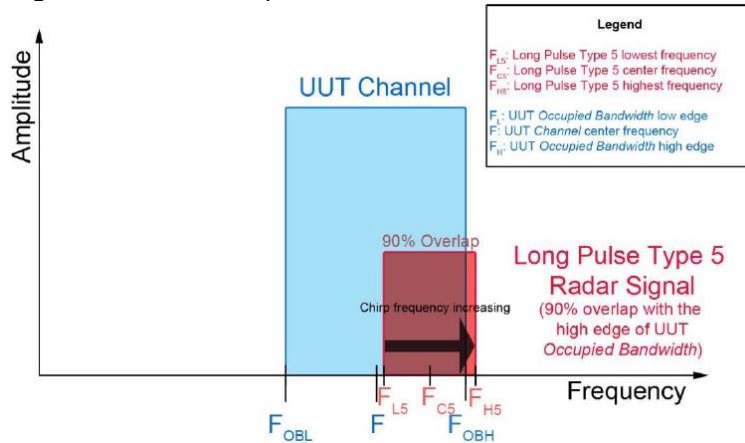

For subset case 1: the center frequency of the signal generator will remain fixed at the center of the UUT Channel.

For subset case 2: to retain 90% frequency overlap between the radar signal and the UUT Occupied Bandwidth, the center frequency of the signal generator will vary for each of the ten trials in subset case 2. The center frequency of the signal generator for each trial is calculated by:

$$F_L + (0.4 * \text{Chirp Width [in MHz]})$$

For subset case 3: to retain 90% frequency overlap between the radar signal and the UUT Occupied Bandwidth, the center frequency of the signal generator will vary for each of the ten trials in subset case 3. The center frequency of the signal generator for each trial is calculated by:

$$F_H - (0.4 * \text{Chirp Width [in MHz]})$$

The percentage of successful detection is calculated by dividing the sum of the detections for the three subsets by the sum of trials for the three subsets:

$$\frac{\text{TotalWaveformDetections}}{\text{TotalWaveformTrials}} \times 100$$

**Frequency Hopping Radar Test**

Statistical data will be gathered to determine the ability of the device to detect the Frequency Hopping radar test signal (radar type 6) found in Table 7. The device can utilize a test mode to demonstrate when detection occurs to prevent the need to reset the device between trial runs. The probability of successful detection is calculated by:

$$\frac{\text{TotalWaveformDetections}}{\text{TotalWaveformTrials}} \times 100$$

### 5.5.2 Test Procedures

1. One frequency will be chosen from the Operating Channels of the UUT within the 5250-5350 MHz or 5470-5725 MHz bands.
2. In case the UUT is a Master Device, a U-NII device operating as a Client Device will be used and it is assumed that the Client will associate with the UUT (Master). For radiated tests, the emissions of the Radar Waveform generator will be directed towards the Master Device. If the Master Device has antenna gain, the main beam of the antenna will be directed toward the radar emitter. Vertical polarization is used for testing.
3. The TCP protocol unicast data stream was generated by the LanTest software with at least 17% activity ratio over any 100ms period.
4. At time T0 the Radar Waveform generator sends a Burst of pulses for each of the Radar Types 1-6 at DFS Detection Threshold levels on the Operating Channel. An additional 1 dB is added to the radar test signal to ensure it is at or above the DFS Detection Threshold, accounting for equipment variations/errors.
5. Observe the transmissions of the EUT at the end of the Burst on the Operating Channel for duration greater than 10 seconds for Radar Types 1-4 and 6 to ensure detection occurs.
6. Observe the transmissions of the EUT at the end of the Burst on the Operating Channel for duration greater than 22 seconds for Long Pulse Radar Type 5 to ensure detection occurs.

**Channel Bandwidth 20MHz/ 5300MHz**

Detection = Y, No Detection = N						
Trial Number	Type 1	Type 2	Type 3	Type 4	Type 5	Type 6
1	Y	Y	Y	Y	Y	Y
2	Y	Y	Y	Y	Y	Y
3	Y	Y	Y	N	Y	Y
4	Y	Y	Y	Y	Y	Y
5	Y	Y	Y	N	Y	Y
6	Y	Y	Y	Y	Y	Y
7	Y	Y	Y	Y	Y	Y
8	Y	Y	Y	N	Y	Y
9	Y	Y	N	Y	Y	Y
10	Y	Y	Y	Y	Y	Y
11	Y	Y	N	Y	Y	Y
12	Y	N	Y	Y	Y	Y
13	Y	Y	Y	Y	Y	Y
14	Y	Y	Y	Y	Y	Y
15	Y	Y	Y	Y	Y	Y
16	Y	Y	Y	Y	Y	Y
17	Y	Y	Y	Y	Y	Y
18	Y	Y	Y	N	Y	Y
19	Y	Y	Y	Y	Y	Y
20	Y	Y	Y	Y	Y	Y
21	Y	Y	Y	Y	N	Y
22	Y	Y	Y	Y	Y	Y
23	Y	Y	Y	Y	Y	Y
24	Y	Y	Y	N	Y	Y
25	Y	Y	Y	N	Y	Y
26	Y	Y	N	Y	Y	Y
27	Y	Y	Y	Y	Y	Y
28	Y	Y	Y	Y	Y	Y
29	Y	Y	Y	Y	Y	Y
30	Y	Y	Y	Y	Y	Y
<b>Number of Successful Detections</b>	<b>30</b>	<b>29</b>	<b>27</b>	<b>24</b>	<b>29</b>	<b>30</b>
<b>Percentage of Successful Detection (%)</b>	<b>100.00%</b>	<b>96.67%</b>	<b>90.00%</b>	<b>80.00%</b>	<b>96.67%</b>	<b>100.00%</b>
<b>Limit(%)</b>	<b>≥ 60%</b>	<b>≥ 60%</b>	<b>≥ 60%</b>	<b>≥ 60%</b>	<b>≥ 80%</b>	<b>≥ 70%</b>
<b>Average Probability of Radar Type 1~4 (%)</b>				<b>91.67 % (≥80%)</b>		

**Channel Bandwidth 40MHz/ 5310MHz**

Detection = Y, No Detection = N						
Trial Number	Type 1	Type 2	Type 3	Type 4	Type 5	Type 6
1	Y	Y	Y	Y	Y	Y
2	Y	Y	Y	N	Y	Y
3	Y	Y	Y	N	Y	Y
4	Y	Y	Y	Y	Y	Y
5	Y	Y	Y	Y	Y	Y
6	Y	N	Y	Y	Y	Y
7	Y	Y	Y	N	Y	Y
8	Y	Y	Y	Y	N	Y
9	Y	Y	Y	N	Y	Y
10	Y	Y	N	Y	Y	Y
11	Y	Y	Y	Y	Y	Y
12	Y	Y	Y	Y	Y	Y
13	Y	Y	N	N	Y	Y
14	Y	Y	Y	Y	Y	Y
15	Y	Y	Y	Y	Y	Y
16	Y	N	Y	N	Y	Y
17	Y	N	N	Y	Y	Y
18	Y	Y	Y	Y	Y	Y
19	Y	Y	Y	Y	Y	Y
20	Y	Y	Y	Y	Y	Y
21	N	Y	N	N	N	Y
22	Y	Y	Y	Y	Y	Y
23	Y	Y	Y	Y	Y	Y
24	Y	Y	Y	Y	Y	Y
25	N	Y	Y	Y	Y	Y
26	Y	Y	Y	Y	Y	Y
27	N	Y	Y	Y	Y	Y
28	Y	Y	N	Y	Y	Y
29	Y	Y	N	Y	Y	Y
30	Y	Y	Y	Y	Y	Y
<b>Number of Successful Detections</b>	<b>27</b>	<b>27</b>	<b>24</b>	<b>23</b>	<b>28</b>	<b>30</b>
<b>Percentage of Successful Detection (%)</b>	<b>90.00%</b>	<b>90.00%</b>	<b>80.00%</b>	<b>76.67%</b>	<b>93.33%</b>	<b>100.00%</b>
<b>Limit(%)</b>	<b>≥ 60%</b>	<b>≥ 60%</b>	<b>≥ 60%</b>	<b>≥ 60%</b>	<b>≥ 80%</b>	<b>≥ 70%</b>
<b>Average Probability of Radar Type 1~4 (%)</b>				<b>84.17 % (≥80%)</b>		

**Channel Bandwidth 80MHz/ 5290MHz**

Detection = Y, No Detection = N						
Trial Number	Type 1	Type 2	Type 3	Type 4	Type 5	Type 6
1	Y	Y	Y	Y	N	Y
2	N	Y	Y	N	Y	Y
3	Y	Y	Y	Y	Y	Y
4	Y	Y	Y	Y	Y	Y
5	Y	Y	Y	Y	Y	Y
6	Y	Y	Y	Y	Y	Y
7	Y	Y	Y	N	Y	Y
8	Y	Y	Y	Y	Y	Y
9	Y	Y	Y	Y	Y	Y
10	Y	Y	Y	Y	Y	Y
11	Y	Y	Y	Y	N	Y
12	Y	Y	N	Y	Y	Y
13	Y	Y	N	Y	Y	Y
14	Y	Y	Y	Y	Y	Y
15	Y	Y	Y	Y	Y	Y
16	Y	Y	Y	Y	Y	Y
17	Y	Y	Y	Y	Y	Y
18	Y	Y	Y	Y	Y	Y
19	Y	Y	Y	Y	Y	Y
20	Y	Y	N	N	Y	Y
21	Y	Y	Y	N	N	Y
22	Y	Y	Y	Y	Y	Y
23	Y	Y	N	N	Y	Y
24	Y	Y	Y	Y	Y	Y
25	Y	Y	Y	N	Y	Y
26	Y	Y	Y	N	N	Y
27	Y	Y	N	Y	Y	Y
28	Y	Y	Y	Y	Y	Y
29	Y	Y	Y	N	N	Y
30	Y	Y	N	Y	Y	Y
<b>Number of Successful Detections</b>	<b>29</b>	<b>30</b>	<b>24</b>	<b>22</b>	<b>25</b>	<b>30</b>
<b>Percentage of Successful Detection (%)</b>	<b>96.67%</b>	<b>100.00%</b>	<b>80.00%</b>	<b>73.33%</b>	<b>83.33%</b>	<b>100.00%</b>
<b>Limit(%)</b>	<b>≥ 60%</b>	<b>≥ 60%</b>	<b>≥ 60%</b>	<b>≥ 60%</b>	<b>≥ 80%</b>	<b>≥ 70%</b>
<b>Average Probability of Radar Type 1~4 (%)</b>				<b>87.50 % (≥80%)</b>		

**Channel Bandwidth 20MHz/ 5500MHz**

Detection = Y, No Detection = N						
Trial Number	Type 1	Type 2	Type 3	Type 4	Type 5	Type 6
1	Y	Y	Y	Y	Y	Y
2	Y	Y	Y	N	Y	Y
3	Y	Y	Y	Y	Y	Y
4	Y	Y	Y	Y	Y	Y
5	Y	Y	Y	Y	Y	Y
6	Y	Y	Y	N	Y	Y
7	Y	Y	Y	Y	Y	Y
8	Y	Y	Y	Y	Y	Y
9	Y	Y	Y	Y	Y	Y
10	Y	N	Y	Y	Y	Y
11	Y	Y	Y	Y	Y	N
12	Y	Y	Y	Y	Y	Y
13	Y	Y	Y	Y	Y	Y
14	Y	Y	Y	Y	Y	Y
15	Y	Y	Y	Y	Y	Y
16	Y	Y	Y	Y	Y	Y
17	Y	Y	N	Y	Y	Y
18	Y	Y	Y	Y	Y	Y
19	Y	Y	Y	Y	Y	Y
20	Y	Y	Y	Y	Y	Y
21	Y	Y	Y	Y	Y	Y
22	Y	Y	Y	Y	Y	Y
23	Y	Y	Y	Y	Y	Y
24	Y	Y	Y	Y	Y	Y
25	Y	Y	Y	Y	Y	Y
26	Y	Y	Y	Y	Y	Y
27	Y	Y	Y	Y	Y	Y
28	Y	Y	Y	Y	Y	Y
29	Y	Y	Y	N	Y	Y
30	Y	Y	Y	Y	Y	Y
<b>Number of Successful Detections</b>	<b>30</b>	<b>29</b>	<b>29</b>	<b>27</b>	<b>30</b>	<b>29</b>
<b>Percentage of Successful Detection (%)</b>	<b>100.00%</b>	<b>96.67%</b>	<b>96.67%</b>	<b>90.00%</b>	<b>100.00%</b>	<b>96.67%</b>
<b>Limit(%)</b>	<b>≥ 60%</b>	<b>≥ 60%</b>	<b>≥ 60%</b>	<b>≥ 60%</b>	<b>≥ 80%</b>	<b>≥ 70%</b>
<b>Average Probability of Radar Type 1~4 (%)</b>				<b>95.83 % (≥80%)</b>		

**Channel Bandwidth 40MHz/ 5510MHz**

Detection = Y, No Detection = N						
Trial Number	Type 1	Type 2	Type 3	Type 4	Type 5	Type 6
1	Y	Y	Y	Y	Y	Y
2	Y	Y	Y	Y	Y	Y
3	Y	Y	Y	Y	Y	Y
4	Y	Y	Y	Y	Y	N
5	N	Y	Y	Y	N	Y
6	Y	Y	Y	Y	Y	Y
7	Y	Y	Y	Y	Y	Y
8	Y	Y	Y	Y	Y	Y
9	Y	Y	Y	Y	Y	Y
10	Y	Y	Y	Y	Y	Y
11	Y	Y	Y	Y	Y	Y
12	Y	Y	Y	Y	Y	Y
13	Y	Y	Y	Y	Y	Y
14	Y	Y	Y	Y	Y	Y
15	Y	Y	Y	Y	Y	Y
16	Y	N	Y	Y	Y	Y
17	Y	Y	Y	Y	Y	Y
18	Y	Y	Y	Y	Y	Y
19	Y	Y	Y	Y	Y	Y
20	Y	Y	Y	Y	Y	Y
21	Y	Y	Y	Y	N	Y
22	Y	Y	Y	Y	Y	Y
23	Y	N	Y	Y	Y	Y
24	Y	Y	Y	Y	Y	Y
25	Y	Y	Y	Y	Y	Y
26	Y	Y	Y	Y	Y	Y
27	N	Y	Y	Y	Y	Y
28	Y	Y	Y	Y	Y	Y
29	Y	Y	Y	Y	Y	Y
30	Y	Y	Y	Y	Y	Y
<b>Number of Successful Detections</b>	<b>28</b>	<b>28</b>	<b>30</b>	<b>30</b>	<b>28</b>	<b>29</b>
<b>Percentage of Successful Detection (%)</b>	<b>93.33%</b>	<b>93.33%</b>	<b>100.00%</b>	<b>100.00%</b>	<b>93.33%</b>	<b>96.67%</b>
<b>Limit(%)</b>	<b>≥ 60%</b>	<b>≥ 60%</b>	<b>≥ 60%</b>	<b>≥ 60%</b>	<b>≥ 80%</b>	<b>≥ 70%</b>
<b>Average Probability of Radar Type 1~4 (%)</b>	<b>96.67 % (≥80%)</b>					



**Channel Bandwidth 80MHz/ 5530MHz**

Detection = Y, No Detection = N						
Trial Number	Type 1	Type 2	Type 3	Type 4	Type 5	Type 6
1	Y	Y	Y	Y	Y	Y
2	Y	N	Y	Y	Y	Y
3	Y	Y	Y	Y	Y	Y
4	Y	Y	N	Y	Y	Y
5	Y	Y	N	Y	Y	Y
6	Y	Y	Y	Y	Y	Y
7	Y	Y	Y	Y	Y	Y
8	Y	Y	Y	Y	Y	Y
9	Y	Y	Y	Y	Y	Y
10	Y	Y	Y	Y	Y	Y
11	Y	Y	Y	Y	Y	Y
12	Y	Y	Y	Y	Y	Y
13	Y	Y	Y	Y	Y	Y
14	Y	N	Y	Y	Y	Y
15	Y	Y	N	Y	Y	Y
16	Y	N	Y	Y	Y	Y
17	Y	Y	N	Y	Y	Y
18	Y	Y	Y	Y	Y	Y
19	Y	N	Y	Y	Y	Y
20	Y	Y	Y	Y	Y	Y
21	Y	Y	Y	Y	N	Y
22	Y	Y	Y	Y	Y	Y
23	Y	Y	Y	Y	Y	Y
24	Y	Y	Y	N	Y	Y
25	Y	N	Y	Y	Y	Y
26	Y	Y	Y	N	Y	Y
27	Y	Y	Y	Y	Y	Y
28	Y	N	Y	Y	Y	Y
29	Y	Y	Y	Y	Y	Y
30	Y	Y	Y	Y	Y	Y
<b>Number of Successful Detections</b>	<b>30</b>	<b>24</b>	<b>26</b>	<b>28</b>	<b>29</b>	<b>30</b>
<b>Percentage of Successful Detection (%)</b>	<b>100.00%</b>	<b>80.00%</b>	<b>86.67%</b>	<b>93.33%</b>	<b>96.67%</b>	<b>100.00%</b>
<b>Limit(%)</b>	<b>≥ 60%</b>	<b>≥ 60%</b>	<b>≥ 60%</b>	<b>≥ 60%</b>	<b>≥ 80%</b>	<b>≥ 70%</b>
<b>Average Probability of Radar Type 1~4 (%)</b>	<b>90.00 % (≥80%)</b>					

## 6. Measurement Equipment List & Calibration Status

Name of Equipment	Manufacturer	Type/Model	Serial Number	Calibration Date	Calibration Due
Coaxial Cable	Woken	WC12	DC004	06/28/2019	06/27/2020
Horn Antenna	ETS LINDGREN	3117	00055165	07/31/2019	07/30/2020
Horn Antenna	TRC	HA-0502	06	07/31/2019	07/30/2020
Spectrum Analyzer	R&S	FSU 26	100258	06/20/2019	06/19/2020
Spectrum Analyzer	R&S	FSU8	200114	07/29/2019	07/28/2020
Vector Signal Generator	R&S	SMU 200A	101480	03/27/2019	03/26/2020

**--End of Test Report--**

## APPENDIX I Radar Test Waveforms

### Short Pulse Radar Test Waveforms

#### Radar Type 1

Trial #	Number of Pulses per Burst	Pulse Width (μsec)	PRI (μs)	Pulse Repetition Frequency Number
1	74	1	718	11
2	81	1	658	8
3	92	1	578	4
4	70	1	758	13
5	62	1	858	18
6	63	1	838	17
7	67	1	798	15
8	61	1	878	19
9	68	1	778	14
10	83	1	638	7
11	76	1	698	10
12	65	1	818	16
13	102	1	518	1
14	78	1	678	9
15	72	1	738	12
16	50	1	1059	
17	34	1	1561	
18	86	1	617	
19	83	1	641	
20	25	1	2116	
21	59	1	902	
22	21	1	2550	
23	25	1	2147	
24	20	1	2678	
25	57	1	931	
26	93	1	571	
27	27	1	2007	
28	19	1	2781	
29	26	1	2060	
30	20	1	2757	

**Radar Type 2**

Trial #	Number of Pulses per Burst	Pulse Width (μsec)	PRI (μs)
1	27	4.2	206
2	28	4.3	211
3	27	1.7	208
4	27	3.6	227
5	24	1.5	171
6	23	1.5	195
7	24	4.5	166
8	26	1.7	225
9	28	3.4	222
10	27	1.6	203
11	29	3	226
12	27	4.4	186
13	25	2.7	150
14	27	4.3	188
15	27	4	163
16	25	3.1	186
17	27	4	170
18	25	1.9	155
19	24	1.7	180
20	26	3.7	213
21	24	3.2	194
22	25	2.7	196
23	29	2.2	155
24	24	4.8	230
25	26	4.1	156
26	28	3.5	209
27	24	1.5	161
28	26	3.5	210
29	26	1.6	210
30	23	4.2	161

**Radar Type 3**

Trial #	Number of Pulses per Burst	Pulse Width (μsec)	PRI (μs)
1	18	8	464
2	18	7.7	355
3	18	9.9	368
4	18	6.7	324
5	18	7.6	483
6	17	7.7	332
7	16	7	208
8	18	9	459
9	17	7.5	262
10	16	9.8	203
11	16	8.4	357
12	16	7.8	355
13	16	9.1	317
14	17	8.9	278
15	17	6.7	454
16	17	6.1	403
17	17	8.6	405
18	17	6.4	474
19	18	7.3	237
20	18	9.8	286
21	16	8.3	427
22	17	9.3	215
23	18	8.1	218
24	17	9.6	289
25	18	8.4	490
26	17	9.3	431
27	18	7.5	429
28	16	6.6	471
29	16	8.5	434
30	17	7	455

**Radar Type 4**

Trial #	Number of Pulses per Burst	Pulse Width (μsec)	PRI (μs)
1	15	14.6	308
2	16	14.8	436
3	14	16.1	366
4	15	14.6	389
5	14	11.7	388
6	14	13.4	391
7	14	18.5	466
8	14	17.5	272
9	15	16.4	338
10	14	16.6	439
11	14	14.2	383
12	13	13.4	438
13	15	19	325
14	13	11.8	256
15	13	19.2	449
16	15	12.3	338
17	15	15.5	399
18	13	11.6	411
19	15	17.2	482
20	13	16.9	366
21	14	13.2	416
22	14	14.1	290
23	12	15.1	220
24	14	16	494
25	13	12.9	381
26	16	12.8	325
27	13	20	208
28	13	16.7	335
29	12	18.7	323
30	12	17.1	206

**Long Pulse Radar Test Waveforms**

**Radar Type 5\_ Overview**

Trial #	Minimum Chirp Widtg(MHz)	Subset
1	6	1
2	20	1
3	16	1
4	19	1
5	17	1
6	8	1
7	11	1
8	20	1
9	20	1
10	5	1
11	16	2
12	12	2
13	15	2
14	18	2
15	17	2
16	17	2
17	15	2
18	10	2
19	17	2
20	15	2
21	6	3
22	5	3
23	13	3
24	6	3
25	10	3
26	6	3
27	15	3
28	9	3
29	10	3
30	18	3

Report No.: T200205W01-RP1

**Radar Type 5\_Trial 1**

Burst	Number of Pulses	Pulse Width (μsec)	Chirp Width (MHz)	Pulse 1-to-2 PRI (μsec)	Pulse 2-to-3 PRI (μsec)	Start Location Within Interval (msec)
1	1	89.1	6			143.451
2	2	75.4	6	1044		183.48
3	1	55.9	6			395.92
4	2	55.6	6	1512		380.99
5	3	56.5	6	1380	1910	425.16
6	2	87.8	6	1518		356.51
7	1	96.9	6			370.63
8	3	81.3	6	1515	1227	57.3
9	3	71.5	6	1689	1096	572.14
10	3	62.9	6	1419	1021	232.74
11	2	61.7	6	1953		113.57
12	3	90.3	6	1304	1810	586.14
13	3	73.6	6	1386	1020	160.84
14	1	99	6			309.64
15	2	52.7	6	1977		572.51
16	3	86.2	6	1857	1807	4.68
17	2	97.6	6	1146		567.4
18	1	60	6			502.7
19	2	86.7	6	1030		225.2
20	2	56.3	6	1935		500.7

**Radar Type 5\_Trial 2**

Burst	Number of Pulses	Pulse Width (μsec)	Chirp Width (MHz)	Pulse 1-to-2 PRI (μsec)	Pulse 2-to-3 PRI (μsec)	Start Location Within Interval (msec)
1	2	70.7	20	1579		850.754
2	3	71.5	20	1752	1714	703.213
3	1	56.9	20			18.346
4	2	94	20	1140		26.369
5	2	92.9	20	1658		726.882
6	2	65.9	20	1542		29.005
7	1	96.3	20			693.368
8	3	65.8	20	1717	1018	222.222
9	2	78.9	20	1565		153.515
10	2	86.3	20	1741		704.578
11	2	99.7	20	1651		421.861
12	1	53	20			741.154
13	1	94.7	20			441.877



**Radar Type 5\_Trial 3**

Burst	Number of Pulses	Pulse Width (μsec)	Chirp Width (MHz)	Pulse 1-to-2 PRI (μsec)	Pulse 2-to-3 PRI (μsec)	Start Location Within Interval (msec)
1	2	85.4	16	1856		1206.45
2	1	95.1	16			1337.13
3	3	91.4	16	1506	1952	29.33
4	2	53.2	16	1446		512.14
5	2	71.6	16	1356		1030.58
6	2	68.8	16	1630		143.72
7	3	94.5	16	1385	1278	303.64
8	1	64.8	16			714.6

**Radar Type 5\_Trial 4**

Burst	Number of Pulses	Pulse Width (μsec)	Chirp Width (MHz)	Pulse 1-to-2 PRI (μsec)	Pulse 2-to-3 PRI (μsec)	Start Location Within Interval (msec)
1	2	54.1	19	1433		773.19
2	2	65.2	19	1315		16.561
3	2	76	19	1850		756.934
4	2	66.3	19	1522		295.481
5	3	94.4	19	1347	1548	468.899
6	1	81	19			638.996
7	3	70.4	19	1057	1715	700.653
8	1	78.7	19			822.25
9	1	79.4	19			426.627
10	3	82.8	19	1171	1808	130.014
11	1	76.5	19			141.791
12	2	84.1	19	1706		247.389
13	1	79.6	19			7.786
14	2	76.3	19	1493		641.143

**Radar Type 5\_Trial 5**

Burst	Number of Pulses	Pulse Width (μsec)	Chirp Width (MHz)	Pulse 1-to-2 PRI (μsec)	Pulse 2-to-3 PRI (μsec)	Start Location Within Interval (msec)
1	3	98.5	17	1759	1733	715.993
2	2	86.5	17	1787		613.51
3	1	89.9	17			438.4
4	2	91	17	1607		219.56
5	2	57.8	17	1130		1055.79
6	3	80.2	17	1648	1087	695.92
7	2	53.2	17	1928		1172.21
8	2	89	17	1135		769.54
9	3	66.9	17	1976	1746	21.63
10	3	85.7	17	1807	1076	747.7

**Radar Type 5\_Trial 6**

Burst	Number of Pulses	Pulse Width (μsec)	Chirp Width (MHz)	Pulse 1-to-2 PRI (μsec)	Pulse 2-to-3 PRI (μsec)	Start Location Within Interval (msec)
1	3	68.6	8	1699	1380	711.668
2	3	57.2	8	1434	1792	48.659
3	2	76.2	8	1489		508.424
4	1	89.7	8			377.951
5	3	89.1	8	1724	1326	412.329
6	1	58.6	8			675.746
7	1	52.4	8			518.333
8	3	95.1	8	1536	1046	108.06
9	1	70.8	8			698.737
10	2	92.9	8	1250		303.014
11	2	82.8	8	1771		166.061
12	3	54	8	1222	1244	798.029
13	2	89.7	8	1791		219.986
14	2	53.3	8	1410		550.143

**Radar Type 5\_Trial 7**

Burst	Number of Pulses	Pulse Width (μsec)	Chirp Width (MHz)	Pulse 1-to-2 PRI (μsec)	Pulse 2-to-3 PRI (μsec)	Start Location Within Interval (msec)
1	2	50.3	11	1368		683.429
2	3	58.4	11	1060	1379	386.718
3	3	87	11	1974	1785	45.285
4	2	52.2	11	1145		264.393
5	3	63.6	11	1017	1851	70.101
6	2	89.2	11	1077		674.608
7	1	57.4	11			693.326
8	1	93.9	11			134.394
9	1	73.6	11			599.581
10	2	81.6	11	1934		109.569
11	3	89.8	11	1325	1644	420.396
12	3	55.7	11	1653	1111	351.654
13	2	71.3	11	1668		60.662
14	2	92	11	1437		440.119
15	1	95.8	11			216.747
16	2	97.8	11	1522		487.565
17	2	78.5	11	1141		189.682

**Radar Type 5\_Trial 8**

Burst	Number of Pulses	Pulse Width (μsec)	Chirp Width (MHz)	Pulse 1-to-2 PRI (μsec)	Pulse 2-to-3 PRI (μsec)	Start Location Within Interval (msec)
1	2	87.2	20	1499		1084.13
2	2	78.6	20	1907		1024.88
3	1	83.9	20			870.04
4	2	59.9	20	1698		222.22
5	2	74.7	20	1020		430.23
6	3	93	20	1771	1729	306.53
7	2	79.1	20	1070		420.49
8	2	59.9	20	1615		554.17
9	1	87.4	20			1147.9
10	1	89.7	20			467.2

**Radar Type 5\_Trial 9**

Burst	Number of Pulses	Pulse Width (μsec)	Chirp Width (MHz)	Pulse 1-to-2 PRI (μsec)	Pulse 2-to-3 PRI (μsec)	Start Location Within Interval (msec)
1	1	67.3	20			968.756
2	2	50.8	20	1358		803.12
3	2	82.9	20	1481		964.01
4	2	86.1	20	1331		524.69
5	1	73.8	20			811.52
6	2	79.1	20	1052		681.53
7	1	86.7	20			624.35
8	3	75	20	1205	1057	116.45
9	1	75	20			760.45
10	2	65.1	20	1539		869.7
11	3	75	20	1954	1458	670.3
12	1	61.6	20			642.6

**Radar Type 5\_Trial 10**

Burst	Number of Pulses	Pulse Width (μsec)	Chirp Width (MHz)	Pulse 1-to-2 PRI (μsec)	Pulse 2-to-3 PRI (μsec)	Start Location Within Interval (msec)
1	2	86.7	5	1847		578.801
2	2	57.9	5	1816		466.901
3	2	65.9	5	1157		502.102
4	3	55.7	5	1698	1941	334.833
5	3	88.6	5	1524	1518	230.574
6	1	54.5	5			454.175
7	3	58.1	5	1610	1814	97.906
8	1	60.3	5			273.187
9	3	84.8	5	1578	1096	207.048
10	1	96.1	5			135.789
11	2	66.1	5	1523		325.681
12	2	67.6	5	1004		25.772
13	2	77	5	1906		56.053
14	2	51.9	5	1396		104.244
15	3	99.9	5	1878	1100	315.645
16	2	64.7	5	1288		400.406
17	1	51.3	5			404.537
18	2	57.5	5	1101		81.458
19	2	90.1	5	1778		412.179

**Radar Type 5\_Trial 11**

Burst	Number of Pulses	Pulse Width (μsec)	Chirp Width (MHz)	Pulse 1-to-2 PRI (μsec)	Pulse 2-to-3 PRI (μsec)	Start Location Within Interval (msec)
1	2	96.5	16	1947		385.424
2	2	87.6	16	1973		685.403
3	1	65.2	16			329.436
4	3	89.4	16	1143	1159	796.029
5	2	82.7	16	1577		78.112
6	1	97.4	16			273.195
7	3	59.5	16	1604	1623	387.608
8	2	92.6	16	1720		620.982
9	3	79.5	16	1689	1006	445.985
10	3	97.5	16	1629	1347	775.018
11	2	62.3	16	1587		437.261
12	2	59.7	16	1877		806.754
13	1	73.7	16			629.277

**Radar Type 5\_Trial 12**

Burst	Number of Pulses	Pulse Width (μsec)	Chirp Width (MHz)	Pulse 1-to-2 PRI (μsec)	Pulse 2-to-3 PRI (μsec)	Start Location Within Interval (msec)
1	1	85.1	12			247.665
2	3	68.9	12	1666	1887	459.51
3	2	67.1	12	1625		620.2
4	1	61.9	12			700.38
5	3	56.4	12	1128	1290	386.13
6	3	63.2	12	1915	1876	289.9
7	2	91.9	12	1888		207.6
8	3	67.4	12	1044	1176	428.97
9	2	67.7	12	1984		62.03
10	3	73.4	12	1945	1035	315.32
11	1	72.7	12			215.73
12	2	79.3	12	1616		159.92
13	2	62.9	12	1501		748.8
14	2	78.5	12	1562		748.6
15	2	87.2	12	1253		757.5

**Radar Type 5\_Trial 13**

Burst	Number of Pulses	Pulse Width (μsec)	Chirp Width (MHz)	Pulse 1-to-2 PRI (μsec)	Pulse 2-to-3 PRI (μsec)	Start Location Within Interval (msec)
1	3	73.8	15	1097	1453	403.781
2	1	60.7	15			323.162
3	1	55.7	15			275.352
4	2	96.6	15	1915		620.593
5	2	61.2	15	1186		105.944
6	1	94.1	15			379.695
7	2	63.3	15	1083		126.266
8	3	82.9	15	1545	1651	49.357
9	3	57.3	15	1565	1923	14.658
10	2	65.5	15	1125		308.239
11	2	65.9	15	1658		468.951
12	2	76.6	15	1034		528.732
13	2	56.1	15	1605		165.403
14	2	54.6	15	1564		96.444
15	2	90.2	15	1799		380.975
16	1	97.9	15			296.766
17	2	57.7	15	1088		518.737
18	2	57.2	15	1920		49.658
19	2	67	15	1195		72.279

**Radar Type 5\_Trial 14**

Burst	Number of Pulses	Pulse Width (μsec)	Chirp Width (MHz)	Pulse 1-to-2 PRI (μsec)	Pulse 2-to-3 PRI (μsec)	Start Location Within Interval (msec)
1	2	88.3	18	1083		956.305
2	3	59.5	18	1054	1846	626.04
3	3	82.8	18	1651	1422	598.17
4	3	77.1	18	1483	1069	775.83
5	3	62.8	18	1774	1267	560.76
6	2	80.3	18	1906		1379.58
7	3	84.9	18	1410	1861	1277.1
8	2	88.2	18	1449		1064

**Radar Type 5\_Trial 15**

Burst	Number of Pulses	Pulse Width (μsec)	Chirp Width (MHz)	Pulse 1-to-2 PRI (μsec)	Pulse 2-to-3 PRI (μsec)	Start Location Within Interval (msec)
1	2	98	17	1466		965.962
2	3	69.5	17	1276	1293	570.787
3	2	95.8	17	1967		581.853
4	2	84.4	17	1490		756.06
5	3	76.2	17	1764	1878	270.547
6	3	68.6	17	1750	1290	1219.413
7	2	54.6	17	1823		491.45
8	3	84.9	17	1529	1646	224.217
9	2	71.6	17	1149		876.733

**Radar Type 5\_Trial 16**

Burst	Number of Pulses	Pulse Width (μsec)	Chirp Width (MHz)	Pulse 1-to-2 PRI (μsec)	Pulse 2-to-3 PRI (μsec)	Start Location Within Interval (msec)
1	1	94.3	17			432.948
2	3	62.7	17	1926	1663	676.8
3	3	61.5	17	1490	1730	138.38
4	2	52.7	17	1542		61.95
5	2	63.1	17	1247		355.57
6	1	84.3	17			786.45
7	1	84.1	17			552.16
8	3	68.8	17	1344	1521	55.51
9	2	60.6	17	1024		405.26
10	2	64.3	17	1577		111.85
11	2	96.9	17	1217		266.07
12	2	55.6	17	1253		501.81
13	2	51.3	17	1946		106.23
14	3	58.2	17	1029	1182	337.1
15	1	68.1	17			62.1

**Radar Type 5\_Trial 17**

Burst	Number of Pulses	Pulse Width (μsec)	Chirp Width (MHz)	Pulse 1-to-2 PRI (μsec)	Pulse 2-to-3 PRI (μsec)	Start Location Within Interval (msec)
1	2	77.2	15	1914		126.908
2	2	55.4	15	1807		16.838
3	3	69.1	15	1607	1203	64.982
4	2	85.5	15	1809		566.673
5	1	87.6	15			106.344
6	2	58.6	15	1126		315.575
7	2	81	15	1821		443.556
8	2	56.7	15	1611		524.767
9	1	91.6	15			104.578
10	3	90.9	15	1615	1122	216.069
11	3	60.6	15	1376	1235	53.581
12	2	90.8	15	1761		327.552
13	2	86.9	15	1724		189.263
14	3	96.8	15	1861	1510	530.624
15	3	91.6	15	1739	1235	403.295
16	3	52.4	15	1077	1925	494.146
17	2	56.7	15	1028		343.537
18	1	90	15			470.858
19	2	69.6	15	1108		100.379



**Radar Type 5\_Trial 18**

Burst	Number of Pulses	Pulse Width (μsec)	Chirp Width (MHz)	Pulse 1-to-2 PRI (μsec)	Pulse 2-to-3 PRI (μsec)	Start Location Within Interval (msec)
1	3	53.5	10	1656	1194	450.476
2	3	75.6	10	1840	1419	517.658
3	2	75.2	10	1116		147.585
4	3	85.2	10	1062	1090	548.773
5	2	94.9	10	1724		602.521
6	3	96.1	10	1648	1118	223.698
7	1	72.3	10			535.266
8	2	90	10	1180		426.914
9	1	58.1	10			189.831
10	2	73.4	10	1170		263.569
11	3	58.1	10	1838	1889	637.566
12	2	68	10	1267		88.544
13	1	73.6	10			330.682
14	2	85	10	1437		574.079
15	2	66.3	10	1877		586.247
16	2	70.2	10	1189		576.465
17	2	76.5	10	1020		236.982

**Radar Type 5\_Trial 19**

Burst	Number of Pulses	Pulse Width (μsec)	Chirp Width (MHz)	Pulse 1-to-2 PRI (μsec)	Pulse 2-to-3 PRI (μsec)	Start Location Within Interval (msec)
1	2	92.2	17	1710		345.794
2	1	75.4	17			771.311
3	1	94.5	17			751.092
4	1	53.1	17			176.193
5	2	95.5	17	1129		1026.934
6	3	84.9	17	1009	1245	528.475
7	2	76.3	17	1398		792.895
8	2	81.3	17	1557		518.596
9	2	58.6	17	1102		583.307
10	2	67.5	17	1210		264.818
11	1	55.1	17			715.909

**Radar Type 5\_Trial 20**

Burst	Number of Pulses	Pulse Width (μsec)	Chirp Width (MHz)	Pulse 1-to-2 PRI (μsec)	Pulse 2-to-3 PRI (μsec)	Start Location Within Interval (msec)
1	1	95.2	15			944.866
2	2	76.9	15	1068		750.307
3	1	81.7	15			327.373
4	1	89.2	15			41.46
5	3	63.9	15	1319	1393	828.937
6	2	91.9	15	1208		990.413
7	3	74.9	15	1558	1608	615.77
8	2	97	15	1381		407.177
9	3	67.6	15	1195	1312	275.433

**Radar Type 5\_Trial 21**

Burst	Number of Pulses	Pulse Width (μsec)	Chirp Width (MHz)	Pulse 1-to-2 PRI (μsec)	Pulse 2-to-3 PRI (μsec)	Start Location Within Interval (msec)
1	2	97.1	6	1836		418.429
2	3	50.5	6	1622	1504	487.871
3	1	81	6			498.132
4	2	69.8	6	1633		595.973
5	3	80.4	6	1164	1725	312.954
6	2	94.9	6	1241		240.325
7	3	92.1	6	1089	1838	488.076
8	2	90.3	6	1695		125.107
9	3	78.6	6	1200	1446	117.788
10	1	97.7	6			208.639
11	2	85.3	6	1899		393.361
12	3	79.6	6	1702	1248	253.362
13	2	71.1	6	1748		438.873
14	1	76.9	6			432.464
15	3	99.8	6	1266	1314	299.735
16	1	50.2	6			607.516
17	2	65.7	6	1108		143.337
18	2	95.3	6	1578		189.358
19	3	76.3	6	1417	1911	577.879

**Radar Type 5\_Trial 22**

Burst	Number of Pulses	Pulse Width (μsec)	Chirp Width (MHz)	Pulse 1-to-2 PRI (μsec)	Pulse 2-to-3 PRI (μsec)	Start Location Within Interval (msec)
1	2	61.2	5	1227		146.867
2	1	58.1	5			596.248
3	3	98.6	5	1958	1035	411.435
4	2	86.4	5	1527		372.123
5	2	62.2	5	1986		88.901
6	2	78.4	5	1320		642.518
7	2	62.6	5	1518		402.336
8	3	77.1	5	1424	1792	53.234
9	2	51.2	5	1513		500.651
10	3	88.4	5	1876	1766	373.229
11	1	67.2	5			412.926
12	1	89.2	5			670.544
13	2	77.2	5	1592		563.112
14	2	87.1	5	1959		176.929
15	1	69.3	5			181.047
16	2	56.5	5	1734		569.765
17	3	75.7	5	1786	1807	121.682

**Radar Type 5\_Trial 23**

Burst	Number of Pulses	Pulse Width (μsec)	Chirp Width (MHz)	Pulse 1-to-2 PRI (μsec)	Pulse 2-to-3 PRI (μsec)	Start Location Within Interval (msec)
1	2	70.4	13	1847		1170.35
2	2	62.8	13	1400		921.447
3	1	56.2	13			553.463
4	1	57.1	13			209.04
5	2	77.1	13	1664		564.467
6	2	52.6	13	1999		652.523
7	3	63.5	13	1651	1941	1241.41
8	3	55.3	13	1100	1143	756.767
9	1	58.4	13			17.033

**Radar Type 5\_Trial 24**

Burst	Number of Pulses	Pulse Width (μsec)	Chirp Width (MHz)	Pulse 1-to-2 PRI (μsec)	Pulse 2-to-3 PRI (μsec)	Start Location Within Interval (msec)
1	3	56.3	6	1290	1203	395.957
2	2	88.3	6	1384		395.161
3	3	60	6	1931	1970	539.252
4	3	57.8	6	1749	1785	397.173
5	3	79.2	6	1525	1636	306.114
6	1	65.4	6			147.275
7	2	89.4	6	1486		74.796
8	1	84.3	6			136.757
9	2	56.1	6	1778		584.398
10	1	86.5	6			19.179
11	1	54.2	6			418.521
12	2	74.4	6	1691		310.342
13	2	97.2	6	1598		456.523
14	2	92.5	6	1715		117.794
15	2	68	6	1740		619.105
16	2	69.1	6	1635		291.906
17	2	56.9	6	1521		406.537
18	3	97.2	6	1542	1228	324.058
19	2	82.2	6	1648		178.179

**Radar Type 5\_Trial 25**

Burst	Number of Pulses	Pulse Width (μsec)	Chirp Width (MHz)	Pulse 1-to-2 PRI (μsec)	Pulse 2-to-3 PRI (μsec)	Start Location Within Interval (msec)
1	3	84.9	10	1650	1754	816.585
2	3	62.7	10	1492	1393	312.897
3	1	84.9	10			408.594
4	3	89.1	10	1609	1391	554.271
5	1	79.3	10			698.099
6	2	77.4	10	1624		142.756
7	2	67.6	10	1246		4.563
8	1	74	10			31.61
9	2	98.8	10	1592		335.277
10	2	50.9	10	1904		794.584
11	1	78.2	10			377.121
12	3	92.9	10	1349	1652	230.889
13	2	72.7	10	1422		175.586
14	1	64.2	10			765.443

**Radar Type 5\_Trial 26**

Burst	Number of Pulses	Pulse Width (μsec)	Chirp Width (MHz)	Pulse 1-to-2 PRI (μsec)	Pulse 2-to-3 PRI (μsec)	Start Location Within Interval (msec)
1	3	64.3	6	1472	1973	825.28
2	1	55.4	6			711.537
3	3	96.9	6	1332	1912	416.234
4	2	86	6	1691		149.561
5	1	59	6			671.039
6	1	69.8	6			678.396
7	3	80.2	6	1474	1053	716.833
8	1	96.7	6			359.06
9	3	62.9	6	1755	1332	443.057
10	3	75.2	6	1050	1625	198.524
11	2	94.7	6	1248		239.631
12	2	78.5	6	1719		435.419
13	3	89.6	6	1016	1025	486.486
14	2	81.7	6	1654		399.543

**Radar Type 5\_Trial 27**

Burst	Number of Pulses	Pulse Width (μsec)	Chirp Width (MHz)	Pulse 1-to-2 PRI (μsec)	Pulse 2-to-3 PRI (μsec)	Start Location Within Interval (msec)
1	1	86.9	15			161.26
2	2	79.4	15	1099		1.903
3	1	89.2	15			6.592
4	1	62.1	15			367.383
5	2	80.5	15	1972		330.874
6	1	70.8	15			591.935
7	3	67.9	15	1999	1889	277.726
8	3	94.8	15	1502	1184	52.607
9	1	56	15			4.128
10	2	52.7	15	1562		13.329
11	2	76.4	15	1061		457.011
12	2	82.5	15	1035		15.212
13	2	69.5	15	1766		372.113
14	1	96.2	15			347.724
15	3	63.2	15	1070	1769	35.385
16	2	86.9	15	1478		536.016
17	2	95.7	15	1895		503.237
18	2	62.4	15	1668		241.758
19	2	69	15	1477		129.079

**Radar Type 5\_Trial 28**

Burst	Number of Pulses	Pulse Width (μsec)	Chirp Width (MHz)	Pulse 1-to-2 PRI (μsec)	Pulse 2-to-3 PRI (μsec)	Start Location Within Interval (msec)
1	2	75.2	9	1670		547.729
2	2	78.3	9	1412		625.83
3	1	67	9			364.13
4	2	96.5	9	1648		576.07
5	2	55.8	9	1687		564.38
6	2	66.7	9	1064		752.54
7	2	55.5	9	1499		547.88
8	3	73.6	9	1098	1331	50.9
9	2	84.8	9	1336		345.4
10	3	61.1	9	1282	1920	106.13
11	2	85.6	9	1107		83.73
12	2	62.9	9	1525		397.37
13	2	57.4	9	1992		726.7
14	2	77.9	9	1072		125.9
15	2	86.7	9	1831		437.8



**Radar Type 5\_Trial 29**

Burst	Number of Pulses	Pulse Width (μsec)	Chirp Width (MHz)	Pulse 1-to-2 PRI (μsec)	Pulse 2-to-3 PRI (μsec)	Start Location Within Interval (msec)
1	2	67.1	10	1055		481.345
2	3	50	10	1213	1643	632.52
3	2	76.8	10	1334		672.44
4	2	99.3	10	1324		695.39
5	2	68.3	10	1866		577.63
6	2	70.3	10	1652		792.52
7	2	64.4	10	1001		83.8
8	1	95.8	10			107.83
9	2	99.7	10	1003		626.97
10	2	78.9	10	1527		608.2
11	3	66.9	10	1852	1607	473.19
12	2	88.1	10	1510		772.21
13	2	82.1	10	1445		80.27
14	2	95	10	1235		344.5
15	3	73.9	10	1507	1808	714.3

**Radar Type 5\_Trial 30**

Burst	Number of Pulses	Pulse Width (μsec)	Chirp Width (MHz)	Pulse 1-to-2 PRI (μsec)	Pulse 2-to-3 PRI (μsec)	Start Location Within Interval (msec)
1	1	58	18			469.686
2	1	57	18			450.96
3	2	82.1	18	1982		873.85
4	2	97.6	18	1472		202.25
5	3	98.3	18	1707	1314	347.85
6	1	53.3	18			157.42
7	3	56.5	18	1764	1440	351.24
8	2	96.2	18	1326		863.14
9	2	52.6	18	1987		48.25
10	3	97.8	18	1403	1958	718.08
11	2	64	18	1960		589.5
12	2	73.1	18	1789		945.7

**Frequency Hopping Radar Test Waveforms**

**Radar Type 6\_Trial 1**

Frequency (GHz)	0	1	2	3	4	5	6	7	8	9
1	5.660	5.466	5.403	5.556	5.706	5.272	5.313	5.443	5.505	5.548
2	5.421	5.292	5.493	5.324	5.641	5.285	5.542	5.571	5.695	5.439
3	5.566	5.413	5.516	5.399	5.588	5.690	5.299	5.642	5.380	5.303
4	5.559	5.681	5.298	5.640	5.392	5.699	5.444	5.339	5.491	5.310
5	5.685	5.315	5.266	5.381	5.633	5.348	5.503	5.480	5.442	5.602
6	5.473	5.404	5.330	5.562	5.688	5.397	5.325	5.423	5.558	5.333
7	5.295	5.306	5.398	5.312	5.604	5.323	5.341	5.628	5.692	5.483
8	5.487	5.630	5.408	5.481	5.609	5.490	5.568	5.646	5.463	5.658
9	5.576	5.309	5.541	5.406	5.538	5.582	5.663	5.250	5.351	5.385
10	5.433	5.307	5.636	5.482	5.596	5.257	5.479	5.617	5.531	5.457

**Radar Type 6\_Trial 2**

Frequency (GHz)	0	1	2	3	4	5	6	7	8	9
1	5.404	5.673	5.496	5.300	5.619	5.393	5.663	5.334	5.310	5.568
2	5.601	5.538	5.659	5.539	5.425	5.363	5.282	5.433	5.301	5.556
3	5.359	5.405	5.452	5.490	5.480	5.434	5.307	5.329	5.295	5.364
4	5.375	5.508	5.472	5.605	5.474	5.372	5.645	5.335	5.297	5.595
5	5.621	5.694	5.477	5.627	5.718	5.436	5.628	5.709	5.279	5.411
6	5.544	5.642	5.346	5.686	5.592	5.580	5.367	5.700	5.475	5.294
7	5.357	5.529	5.421	5.518	5.408	5.400	5.287	5.273	5.286	5.385
8	5.315	5.468	5.602	5.370	5.314	5.582	5.565	5.644	5.353	5.702
9	5.557	5.611	5.466	5.306	5.724	5.704	5.377	5.494	5.255	5.665
10	5.470	5.263	5.447	5.344	5.251	5.599	5.253	5.261	5.591	5.476

**Radar Type 6\_Trial 3**

Frequency (GHz)	0	1	2	3	4	5	6	7	8	9
1	5.293	5.250	5.340	5.552	5.484	5.464	5.280	5.611	5.627	5.283
2	5.639	5.674	5.420	5.447	5.267	5.593	5.500	5.290	5.353	5.586
3	5.258	5.511	5.680	5.608	5.548	5.330	5.264	5.376	5.448	5.339
4	5.382	5.616	5.529	5.565	5.541	5.533	5.367	5.491	5.399	5.479
5	5.413	5.378	5.506	5.691	5.308	5.494	5.287	5.374	5.415	5.686
6	5.477	5.590	5.309	5.636	5.630	5.719	5.295	5.472	5.620	5.564
7	5.482	5.655	5.503	5.662	5.496	5.568	5.701	5.342	5.381	5.251
8	5.326	5.344	5.537	5.254	5.315	5.266	5.285	5.517	5.403	5.625
9	5.508	5.462	5.313	5.501	5.659	5.397	5.598	5.534	5.602	5.470
10	5.350	5.582	5.302	5.336	5.554	5.518	5.314	5.424	5.261	5.260

**Radar Type 6\_Trial 4**

Frequency (GHz)	0	1	2	3	4	5	6	7	8	9
1	5.328	5.322	5.593	5.713	5.269	5.532	5.448	5.687	5.427	5.270
2	5.523	5.264	5.293	5.336	5.715	5.522	5.458	5.419	5.671	5.519
3	5.333	5.271	5.570	5.509	5.387	5.616	5.327	5.254	5.633	5.376
4	5.344	5.352	5.331	5.639	5.424	5.699	5.428	5.581	5.285	5.388
5	5.432	5.625	5.300	5.589	5.324	5.358	5.615	5.396	5.676	5.610
6	5.403	5.647	5.526	5.283	5.504	5.456	5.719	5.382	5.525	5.683
7	5.407	5.426	5.638	5.618	5.720	5.546	5.361	5.652	5.502	5.351
8	5.429	5.360	5.612	5.710	5.437	5.543	5.461	5.465	5.677	5.603
9	5.582	5.636	5.281	5.369	5.549	5.256	5.555	5.298	5.583	5.400
10	5.348	5.692	5.471	5.542	5.599	5.304	5.273	5.499	5.565	5.721

**Radar Type 6\_Trial 5**

Frequency (GHz)	0	1	2	3	4	5	6	7	8	9
1	5.673	5.701	5.514	5.442	5.655	5.477	5.502	5.649	5.325	5.445
2	5.432	5.536	5.704	5.644	5.307	5.349	5.429	5.634	5.651	5.386
3	5.653	5.444	5.451	5.363	5.684	5.592	5.588	5.535	5.700	5.441
4	5.507	5.364	5.255	5.357	5.647	5.664	5.365	5.324	5.629	5.698
5	5.573	5.687	5.654	5.390	5.319	5.561	5.635	5.352	5.696	5.401
6	5.331	5.550	5.420	5.557	5.559	5.417	5.489	5.569	5.504	5.288
7	5.603	5.642	5.641	5.484	5.370	5.475	5.269	5.328	5.600	5.301
8	5.611	5.546	5.311	5.678	5.335	5.606	5.299	5.659	5.462	5.405
9	5.338	5.344	5.541	5.252	5.483	5.595	5.648	5.289	5.521	5.615
10	5.702	5.446	5.459	5.433	5.374	5.565	5.542	5.699	5.623	5.487

**Radar Type 6\_Trial 6**

Frequency (GHz)	0	1	2	3	4	5	6	7	8	9
1	5.392	5.673	5.358	5.413	5.468	5.298	5.440	5.374	5.453	5.373
2	5.281	5.393	5.575	5.276	5.250	5.259	5.352	5.687	5.547	5.483
3	5.670	5.708	5.327	5.554	5.544	5.454	5.499	5.702	5.378	5.351
4	5.640	5.571	5.380	5.717	5.579	5.714	5.493	5.339	5.278	5.449
5	5.710	5.560	5.326	5.638	5.470	5.304	5.405	5.525	5.353	5.682
6	5.578	5.457	5.263	5.287	5.564	5.318	5.407	5.712	5.696	5.558
7	5.598	5.349	5.675	5.521	5.382	5.328	5.586	5.319	5.645	5.491
8	5.492	5.366	5.370	5.681	5.469	5.329	5.289	5.536	5.401	5.519
9	5.372	5.607	5.534	5.520	5.431	5.266	5.555	5.260	5.701	5.649
10	5.705	5.502	5.576	5.390	5.704	5.458	5.417	5.466	5.507	5.362

Report No.: T200205W01-RP1

**Radar Type 6\_Trial 7**

Frequency (GHz)	0	1	2	3	4	5	6	7	8	9
1	5.614	5.478	5.509	5.717	5.482	5.493	5.400	5.532	5.302	5.586
2	5.447	5.466	5.263	5.591	5.716	5.572	5.557	5.288	5.414	5.562
3	5.628	5.513	5.337	5.708	5.511	5.313	5.262	5.483	5.665	5.626
4	5.287	5.627	5.442	5.578	5.340	5.384	5.365	5.526	5.334	5.406
5	5.324	5.486	5.389	5.450	5.679	5.534	5.281	5.301	5.674	5.601
6	5.510	5.341	5.719	5.685	5.677	5.300	5.694	5.377	5.723	5.690
7	5.283	5.397	5.336	5.538	5.440	5.353	5.278	5.521	5.622	5.571
8	5.425	5.317	5.508	5.284	5.405	5.550	5.632	5.630	5.471	5.407
9	5.598	5.260	5.589	5.332	5.609	5.704	5.581	5.697	5.479	5.279
10	5.525	5.517	5.427	5.316	5.559	5.590	5.502	5.678	5.327	5.413

**Radar Type 6\_Trial 8**

Frequency (GHz)	0	1	2	3	4	5	6	7	8	9
1	5.432	5.550	5.563	5.351	5.534	5.700	5.413	5.623	5.511	5.339
2	5.419	5.577	5.687	5.605	5.362	5.469	5.712	5.554	5.445	5.662
3	5.505	5.271	5.487	5.527	5.441	5.415	5.328	5.519	5.716	5.470
4	5.290	5.659	5.431	5.349	5.391	5.543	5.631	5.329	5.449	5.541
5	5.326	5.310	5.430	5.535	5.311	5.610	5.498	5.607	5.368	5.297
6	5.521	5.647	5.324	5.439	5.444	5.696	5.697	5.372	5.673	5.468
7	5.639	5.364	5.305	5.422	5.460	5.690	5.509	5.682	5.382	5.531
8	5.645	5.549	5.692	5.506	5.499	5.658	5.436	5.450	5.279	5.542
9	5.343	5.490	5.507	5.657	5.532	5.496	5.277	5.355	5.545	5.285
10	5.572	5.556	5.510	5.437	5.504	5.523	5.399	5.528	5.689	5.475

**Radar Type 6\_Trial 9**

Frequency (GHz)	0	1	2	3	4	5	6	7	8	9
1	5.713	5.519	5.380	5.417	5.399	5.272	5.415	5.299	5.486	5.654
2	5.393	5.450	5.693	5.328	5.579	5.715	5.344	5.714	5.407	5.556
3	5.622	5.677	5.313	5.384	5.637	5.475	5.470	5.643	5.645	5.596
4	5.326	5.577	5.485	5.361	5.651	5.490	5.542	5.686	5.614	5.266
5	5.319	5.275	5.503	5.394	5.404	5.649	5.559	5.511	5.457	5.663
6	5.512	5.343	5.392	5.432	5.270	5.717	5.476	5.491	5.569	5.389
7	5.540	5.681	5.354	5.462	5.597	5.712	5.611	5.666	5.315	5.335
8	5.684	5.604	5.694	5.561	5.423	5.544	5.459	5.499	5.277	5.673
9	5.718	5.372	5.662	5.271	5.437	5.454	5.310	5.408	5.661	5.697
10	5.688	5.721	5.528	5.554	5.573	5.253	5.436	5.469	5.560	5.633

**Radar Type 6\_Trial 10**

Frequency (GHz)	0	1	2	3	4	5	6	7	8	9
1	5.288	5.404	5.424	5.319	5.287	5.556	5.327	5.704	5.272	5.272
2	5.294	5.359	5.513	5.573	5.317	5.587	5.675	5.368	5.554	5.554
3	5.670	5.630	5.387	5.682	5.604	5.618	5.608	5.619	5.574	5.574
4	5.425	5.479	5.532	5.486	5.720	5.667	5.485	5.577	5.373	5.373
5	5.538	5.534	5.295	5.717	5.256	5.662	5.501	5.410	5.285	5.285
6	5.537	5.377	5.552	5.268	5.254	5.297	5.636	5.409	5.261	5.261
7	5.521	5.321	5.286	5.629	5.313	5.428	5.383	5.454	5.484	5.484
8	5.665	5.564	5.433	5.326	5.375	5.517	5.328	5.504	5.693	5.693
9	5.631	5.531	5.388	5.723	5.439	5.465	5.512	5.264	5.637	5.637
10	5.413	5.307	5.277	5.339	5.708	5.393	5.472	5.580	5.489	5.489

**Radar Type 6\_Trial 11**

Frequency (GHz)	0	1	2	3	4	5	6	7	8	9
1	5.676	5.406	5.365	5.313	5.670	5.460	5.295	5.570	5.603	5.298
2	5.453	5.318	5.681	5.703	5.583	5.326	5.281	5.642	5.262	5.574
3	5.661	5.544	5.335	5.376	5.312	5.591	5.590	5.364	5.260	5.678
4	5.631	5.499	5.500	5.492	5.288	5.449	5.484	5.296	5.526	5.643
5	5.573	5.304	5.402	5.424	5.388	5.557	5.625	5.593	5.600	5.363
6	5.398	5.677	5.300	5.329	5.429	5.606	5.401	5.415	5.608	5.251
7	5.581	5.715	5.588	5.419	5.321	5.355	5.680	5.359	5.381	5.575
8	5.319	5.347	5.462	5.533	5.264	5.504	5.267	5.432	5.614	5.421
9	5.490	5.358	5.696	5.664	5.303	5.309	5.532	5.476	5.666	5.472
10	5.378	5.408	5.416	5.626	5.627	5.390	5.522	5.310	5.668	5.520

**Radar Type 6\_Trial 12**

Frequency (GHz)	0	1	2	3	4	5	6	7	8	9
1	5.506	5.591	5.380	5.626	5.637	5.701	5.444	5.455	5.598	5.420
2	5.404	5.290	5.486	5.323	5.545	5.572	5.335	5.574	5.512	5.395
3	5.526	5.458	5.305	5.490	5.550	5.565	5.712	5.422	5.435	5.466
4	5.462	5.575	5.577	5.409	5.275	5.391	5.253	5.503	5.482	5.623
5	5.306	5.421	5.349	5.394	5.392	5.448	5.438	5.566	5.649	5.423
6	5.433	5.695	5.579	5.273	5.594	5.459	5.687	5.294	5.337	5.498
7	5.360	5.442	5.596	5.693	5.719	5.382	5.717	5.372	5.510	5.491
8	5.607	5.255	5.345	5.471	5.451	5.388	5.601	5.447	5.720	5.553
9	5.629	5.602	5.315	5.261	5.605	5.657	5.383	5.301	5.655	5.613
10	5.419	5.549	5.675	5.627	5.532	5.494	5.576	5.375	5.724	5.509

**Radar Type 6\_Trial 13**

Frequency (GHz)	0	1	2	3	4	5	6	7	8	9
1	5.300	5.419	5.383	5.685	5.316	5.289	5.258	5.324	5.362	5.414
2	5.698	5.582	5.609	5.635	5.257	5.280	5.331	5.518	5.365	5.253
3	5.348	5.296	5.431	5.599	5.673	5.490	5.623	5.716	5.464	5.637
4	5.415	5.271	5.264	5.651	5.275	5.387	5.591	5.587	5.603	5.294
5	5.485	5.507	5.663	5.717	5.600	5.313	5.627	5.460	5.668	5.450
6	5.475	5.347	5.550	5.417	5.697	5.453	5.519	5.489	5.532	5.611
7	5.503	5.568	5.291	5.323	5.506	5.678	5.422	5.544	5.549	5.653
8	5.484	5.584	5.309	5.400	5.579	5.371	5.670	5.445	5.454	5.594
9	5.413	5.448	5.405	5.597	5.336	5.474	5.662	5.567	5.423	5.525
10	5.605	5.378	5.369	5.477	5.517	5.440	5.505	5.689	5.683	5.471

**Radar Type 6\_Trial 14**

Frequency (GHz)	0	1	2	3	4	5	6	7	8	9
1	5.456	5.359	5.336	5.522	5.484	5.457	5.493	5.505	5.518	5.455
2	5.677	5.276	5.502	5.630	5.544	5.688	5.381	5.674	5.629	5.441
3	5.447	5.653	5.312	5.476	5.281	5.258	5.319	5.717	5.250	5.614
4	5.591	5.592	5.480	5.252	5.275	5.658	5.320	5.611	5.563	5.708
5	5.576	5.672	5.644	5.331	5.676	5.390	5.494	5.389	5.624	5.365
6	5.606	5.713	5.504	5.521	5.338	5.645	5.640	5.478	5.702	5.671
7	5.625	5.570	5.673	5.321	5.257	5.682	5.296	5.334	5.302	5.364
8	5.605	5.622	5.330	5.716	5.690	5.615	5.715	5.453	5.618	5.429
9	5.340	5.317	5.527	5.556	5.649	5.586	5.402	5.543	5.490	5.675
10	5.352	5.703	5.723	5.278	5.588	5.370	5.572	5.310	5.542	5.696

**Radar Type 6\_Trial 15**

Frequency (GHz)	0	1	2	3	4	5	6	7	8	9
1	5.621	5.599	5.321	5.630	5.281	5.635	5.625	5.610	5.418	5.588
2	5.435	5.453	5.535	5.319	5.302	5.347	5.421	5.681	5.661	5.328
3	5.663	5.648	5.670	5.495	5.552	5.272	5.656	5.672	5.391	5.587
4	5.346	5.292	5.467	5.377	5.301	5.477	5.716	5.358	5.578	5.570
5	5.378	5.256	5.274	5.671	5.250	5.482	5.541	5.596	5.580	5.268
6	5.503	5.614	5.442	5.704	5.698	5.517	5.611	5.409	5.423	5.449
7	5.295	5.574	5.344	5.430	5.536	5.558	5.696	5.469	5.624	5.283
8	5.266	5.666	5.397	5.633	5.583	5.445	5.323	5.438	5.547	5.705
9	5.466	5.413	5.331	5.510	5.251	5.411	5.439	5.465	5.526	5.398
10	5.446	5.559	5.498	5.350	5.374	5.304	5.506	5.345	5.589	5.499

**Radar Type 6\_Trial 16**

Frequency (GHz)	0	1	2	3	4	5	6	7	8	9
1	5.639	5.648	5.550	5.423	5.354	5.415	5.341	5.309	5.397	5.612
2	5.705	5.590	5.528	5.597	5.654	5.474	5.339	5.589	5.511	5.513
3	5.425	5.676	5.527	5.690	5.669	5.418	5.277	5.606	5.478	5.476
4	5.358	5.681	5.587	5.395	5.479	5.292	5.695	5.678	5.556	5.345
5	5.608	5.714	5.407	5.318	5.685	5.329	5.497	5.572	5.466	5.717
6	5.288	5.656	5.518	5.464	5.592	5.711	5.431	5.356	5.591	5.666
7	5.481	5.286	5.305	5.625	5.504	5.385	5.543	5.462	5.250	5.533
8	5.289	5.579	5.369	5.493	5.400	5.525	5.552	5.542	5.359	5.605
9	5.355	5.708	5.328	5.364	5.489	5.569	5.391	5.461	5.517	5.414
10	5.441	5.261	5.672	5.467	5.465	5.704	5.330	5.501	5.433	5.558

**Radar Type 6\_Trial 17**

Frequency (GHz)	0	1	2	3	4	5	6	7	8	9
1	5.567	5.668	5.331	5.484	5.599	5.637	5.289	5.627	5.721	5.689
2	5.693	5.339	5.373	5.333	5.541	5.667	5.322	5.557	5.285	5.722
3	5.663	5.563	5.644	5.283	5.315	5.275	5.264	5.658	5.279	5.338
4	5.308	5.328	5.524	5.718	5.546	5.433	5.442	5.307	5.311	5.527
5	5.281	5.355	5.405	5.486	5.523	5.374	5.598	5.535	5.345	5.469
6	5.515	5.719	5.451	5.269	5.614	5.503	5.559	5.600	5.487	5.525
7	5.455	5.379	5.564	5.554	5.656	5.715	5.702	5.321	5.571	5.720
8	5.293	5.623	5.502	5.295	5.387	5.344	5.621	5.577	5.259	5.402
9	5.368	5.570	5.553	5.560	5.530	5.263	5.471	5.655	5.371	5.346
10	5.680	5.545	5.290	5.357	5.585	5.616	5.652	5.507	5.692	5.420

**Radar Type 6\_Trial 18**

Frequency (GHz)	0	1	2	3	4	5	6	7	8	9
1	5.696	5.511	5.397	5.490	5.356	5.475	5.333	5.531	5.433	5.281
2	5.451	5.275	5.722	5.719	5.367	5.689	5.500	5.251	5.316	5.714
3	5.446	5.419	5.646	5.368	5.305	5.623	5.365	5.678	5.642	5.579
4	5.664	5.594	5.273	5.534	5.568	5.457	5.418	5.398	5.700	5.337
5	5.662	5.342	5.270	5.400	5.638	5.261	5.648	5.718	5.702	5.584
6	5.606	5.625	5.622	5.634	5.394	5.508	5.562	5.279	5.366	5.437
7	5.465	5.635	5.673	5.683	5.672	5.470	5.268	5.496	5.320	5.262
8	5.417	5.668	5.430	5.274	5.353	5.466	5.604	5.712	5.595	5.266
9	5.440	5.378	5.404	5.452	5.524	5.352	5.421	5.603	5.319	5.395
10	5.406	5.724	5.616	5.667	5.439	5.501	5.380	5.311	5.271	5.360



**Radar Type 6\_Trial 19**

Frequency (GHz)	0	1	2	3	4	5	6	7	8	9
1	5.497	5.458	5.410	5.548	5.326	5.598	5.387	5.695	5.545	5.520
2	5.257	5.684	5.423	5.486	5.450	5.576	5.475	5.611	5.538	5.572
3	5.630	5.661	5.690	5.718	5.552	5.696	5.253	5.348	5.369	5.355
4	5.626	5.513	5.639	5.583	5.409	5.459	5.644	5.419	5.435	5.721
5	5.418	5.701	5.259	5.493	5.637	5.477	5.438	5.272	5.503	5.541
6	5.694	5.693	5.592	5.263	5.282	5.261	5.516	5.252	5.390	5.568
7	5.650	5.266	5.464	5.405	5.627	5.436	5.289	5.710	5.462	5.712
8	5.547	5.421	5.720	5.640	5.658	5.566	5.331	5.605	5.251	5.555
9	5.388	5.303	5.260	5.648	5.679	5.673	5.524	5.460	5.527	5.655
10	5.476	5.269	5.529	5.632	5.434	5.500	5.340	5.669	5.607	5.623

**Radar Type 6\_Trial 20**

Frequency (GHz)	0	1	2	3	4	5	6	7	8	9
1	5.481	5.251	5.284	5.711	5.411	5.693	5.713	5.718	5.504	5.342
2	5.465	5.352	5.455	5.689	5.313	5.300	5.691	5.651	5.391	5.670
3	5.457	5.716	5.346	5.355	5.389	5.445	5.562	5.381	5.676	5.372
4	5.327	5.450	5.435	5.253	5.351	5.474	5.551	5.667	5.591	5.698
5	5.476	5.259	5.722	5.527	5.522	5.458	5.588	5.497	5.603	5.357
6	5.688	5.338	5.572	5.464	5.505	5.370	5.557	5.297	5.277	5.443
7	5.512	5.644	5.569	5.626	5.456	5.531	5.519	5.565	5.697	5.334
8	5.369	5.521	5.400	5.305	5.446	5.382	5.638	5.495	5.362	5.491
9	5.453	5.709	5.684	5.587	5.335	5.645	5.373	5.402	5.553	5.714
10	5.273	5.331	5.597	5.561	5.526	5.628	5.258	5.579	5.412	5.618

**Radar Type 6\_Trial 21**

Frequency (GHz)	0	1	2	3	4	5	6	7	8	9
1	5.376	5.374	5.581	5.616	5.568	5.644	5.558	5.328	5.441	5.696
2	5.266	5.712	5.295	5.336	5.596	5.577	5.487	5.582	5.533	5.672
3	5.522	5.461	5.530	5.541	5.408	5.529	5.435	5.609	5.515	5.422
4	5.714	5.599	5.259	5.379	5.286	5.421	5.444	5.553	5.396	5.356
5	5.440	5.571	5.507	5.397	5.319	5.439	5.473	5.462	5.615	5.594
6	5.489	5.426	5.323	5.641	5.630	5.702	5.656	5.498	5.431	5.436
7	5.639	5.606	5.310	5.661	5.583	5.329	5.273	5.433	5.314	5.275
8	5.678	5.340	5.593	5.564	5.565	5.680	5.718	5.321	5.348	5.663
9	5.618	5.297	5.326	5.667	5.288	5.253	5.720	5.502	5.455	5.562
10	5.674	5.494	5.681	5.598	5.622	5.698	5.587	5.411	5.303	5.518

**Radar Type 6\_Trial 22**

Frequency (GHz)	0	1	2	3	4	5	6	7	8	9
1	5.682	5.421	5.417	5.281	5.463	5.272	5.600	5.656	5.719	5.374
2	5.330	5.504	5.284	5.716	5.450	5.268	5.304	5.507	5.403	5.462
3	5.607	5.313	5.522	5.378	5.646	5.451	5.564	5.493	5.683	5.573
4	5.648	5.416	5.283	5.595	5.604	5.614	5.400	5.652	5.269	5.655
5	5.695	5.367	5.254	5.668	5.553	5.572	5.649	5.264	5.442	5.401
6	5.673	5.538	5.444	5.586	5.618	5.528	5.419	5.510	5.658	5.666
7	5.558	5.680	5.469	5.287	5.386	5.710	5.296	5.323	5.579	5.441
8	5.720	5.591	5.316	5.675	5.306	5.320	5.447	5.691	5.387	5.513
9	5.388	5.344	5.310	5.641	5.435	5.351	5.541	5.376	5.381	5.519
10	5.384	5.413	5.647	5.637	5.353	5.467	5.539	5.471	5.433	5.370

**Radar Type 6\_Trial 23**

Frequency (GHz)	0	1	2	3	4	5	6	7	8	9
1	5.271	5.571	5.365	5.315	5.567	5.364	5.509	5.655	5.288	5.336
2	5.625	5.312	5.261	5.421	5.613	5.502	5.493	5.702	5.551	5.686
3	5.302	5.563	5.480	5.649	5.470	5.499	5.500	5.471	5.292	5.277
4	5.432	5.688	5.362	5.586	5.699	5.555	5.310	5.441	5.265	5.473
5	5.718	5.607	5.376	5.534	5.434	5.355	5.258	5.689	5.326	5.476
6	5.263	5.444	5.478	5.314	5.371	5.700	5.453	5.590	5.333	5.707
7	5.714	5.490	5.286	5.462	5.633	5.461	5.539	5.367	5.704	5.379
8	5.482	5.488	5.516	5.665	5.378	5.610	5.651	5.438	5.408	5.295
9	5.715	5.396	5.526	5.701	5.664	5.667	5.561	5.363	5.587	5.313
10	5.585	5.619	5.418	5.712	5.656	5.270	5.635	5.351	5.608	5.264

**Radar Type 6\_Trial 24**

Frequency (GHz)	0	1	2	3	4	5	6	7	8	9
1	5.597	5.320	5.641	5.718	5.263	5.709	5.267	5.722	5.332	5.550
2	5.270	5.480	5.444	5.268	5.653	5.496	5.577	5.384	5.336	5.646
3	5.637	5.674	5.424	5.357	5.274	5.529	5.658	5.450	5.374	5.413
4	5.490	5.326	5.685	5.387	5.287	5.359	5.695	5.294	5.549	5.375
5	5.313	5.275	5.515	5.471	5.530	5.681	5.708	5.526	5.461	5.356
6	5.645	5.418	5.613	5.323	5.405	5.650	5.522	5.525	5.353	5.428
7	5.301	5.426	5.439	5.537	5.339	5.283	5.510	5.397	5.250	5.720
8	5.543	5.351	5.396	5.558	5.378	5.390	5.568	5.477	5.616	5.652
9	5.297	5.395	5.592	5.520	5.507	5.256	5.711	5.489	5.467	5.625
10	5.317	5.488	5.493	5.630	5.586	5.610	5.524	5.660	5.442	5.346

**Radar Type 6\_Trial 25**

Frequency (GHz)	0	1	2	3	4	5	6	7	8	9
1	5.668	5.631	5.329	5.504	5.259	5.416	5.475	5.470	5.513	5.332
2	5.501	5.615	5.525	5.682	5.308	5.576	5.567	5.680	5.657	5.604
3	5.313	5.382	5.272	5.595	5.469	5.575	5.421	5.352	5.355	5.271
4	5.354	5.561	5.623	5.720	5.371	5.568	5.493	5.496	5.545	5.333
5	5.302	5.334	5.258	5.538	5.316	5.452	5.291	5.467	5.539	5.499
6	5.534	5.520	5.274	5.613	5.276	5.301	5.507	5.579	5.260	5.303
7	5.718	5.360	5.512	5.610	5.722	5.571	5.697	5.646	5.453	5.268
8	5.331	5.429	5.647	5.592	5.373	5.451	5.257	5.367	5.450	5.266
9	5.456	5.637	5.254	5.665	5.630	5.465	5.585	5.511	5.253	5.684
10	5.343	5.408	5.509	5.362	5.378	5.564	5.472	5.454	5.582	5.405

**Radar Type 6\_Trial 26**

Frequency (GHz)	0	1	2	3	4	5	6	7	8	9
1	5.276	5.311	5.380	5.489	5.578	5.537	5.468	5.446	5.520	5.685
2	5.621	5.524	5.339	5.525	5.653	5.698	5.405	5.558	5.351	5.252
3	5.581	5.497	5.326	5.684	5.645	5.289	5.718	5.701	5.435	5.541
4	5.707	5.478	5.313	5.674	5.416	5.526	5.694	5.551	5.584	5.637
5	5.512	5.485	5.370	5.692	5.523	5.264	5.560	5.588	5.464	5.697
6	5.390	5.693	5.429	5.527	5.652	5.538	5.624	5.401	5.585	5.284
7	5.613	5.438	5.418	5.648	5.404	5.453	5.335	5.275	5.672	5.514
8	5.627	5.687	5.379	5.422	5.705	5.629	5.318	5.450	5.257	5.486
9	5.363	5.484	5.506	5.398	5.679	5.604	5.553	5.254	5.593	5.724
10	5.448	5.580	5.592	5.421	5.673	5.260	5.425	5.659	5.400	5.600

**Radar Type 6\_Trial 27**

Frequency (GHz)	0	1	2	3	4	5	6	7	8	9
1	5.385	5.610	5.472	5.586	5.438	5.577	5.321	5.397	5.647	5.663
2	5.256	5.284	5.518	5.532	5.422	5.278	5.645	5.285	5.678	5.499
3	5.270	5.263	5.528	5.585	5.633	5.254	5.439	5.454	5.634	5.598
4	5.542	5.333	5.419	5.462	5.576	5.691	5.544	5.381	5.489	5.295
5	5.546	5.427	5.435	5.708	5.382	5.531	5.561	5.311	5.660	5.682
6	5.399	5.464	5.405	5.478	5.570	5.600	5.298	5.592	5.490	5.394
7	5.354	5.564	5.411	5.547	5.294	5.266	5.650	5.331	5.594	5.604
8	5.273	5.406	5.407	5.701	5.388	5.477	5.710	5.702	5.515	5.643
9	5.555	5.483	5.680	5.459	5.690	5.700	5.465	5.658	5.724	5.632
10	5.395	5.482	5.379	5.339	5.314	5.627	5.606	5.348	5.672	5.582

Report No.: T200205W01-RP1

**Radar Type 6\_Trial 28**

Frequency (GHz)	0	1	2	3	4	5	6	7	8	9
1	5.724	5.507	5.381	5.539	5.542	5.457	5.650	5.331	5.566	5.403
2	5.589	5.413	5.503	5.692	5.398	5.391	5.618	5.345	5.591	5.472
3	5.561	5.337	5.559	5.432	5.380	5.296	5.544	5.449	5.579	5.389
4	5.347	5.634	5.419	5.411	5.673	5.565	5.286	5.385	5.532	5.479
5	5.485	5.578	5.521	5.648	5.484	5.517	5.451	5.660	5.574	5.437
6	5.386	5.462	5.307	5.685	5.524	5.601	5.363	5.309	5.447	5.372
7	5.597	5.262	5.355	5.370	5.512	5.311	5.282	5.680	5.459	5.373
8	5.543	5.540	5.390	5.259	5.594	5.671	5.332	5.414	5.533	5.558
9	5.640	5.623	5.364	5.545	5.572	5.476	5.638	5.661	5.701	5.254
10	5.257	5.526	5.250	5.617	5.426	5.423	5.491	5.494	5.593	5.486

**Radar Type 6\_Trial 29**

Frequency (GHz)	0	1	2	3	4	5	6	7	8	9
1	5.544	5.708	5.644	5.654	5.678	5.373	5.693	5.361	5.308	5.718
2	5.326	5.338	5.482	5.523	5.412	5.329	5.652	5.608	5.454	5.645
3	5.448	5.586	5.711	5.295	5.350	5.384	5.618	5.316	5.581	5.302
4	5.381	5.610	5.499	5.536	5.436	5.283	5.615	5.680	5.346	5.279
5	5.470	5.477	5.672	5.641	5.439	5.513	5.582	5.604	5.613	5.687
6	5.694	5.684	5.410	5.474	5.364	5.390	5.701	5.585	5.337	5.685
7	5.427	5.720	5.311	5.709	5.343	5.369	5.532	5.656	5.383	5.275
8	5.455	5.465	5.259	5.396	5.508	5.280	5.406	5.570	5.723	5.593
9	5.534	5.459	5.303	5.719	5.441	5.575	5.256	5.699	5.375	5.670
10	5.475	5.548	5.367	5.576	5.288	5.460	5.566	5.637	5.567	5.517

**Radar Type 6\_Trial 30**

Frequency (GHz)	0	1	2	3	4	5	6	7	8	9
1	5.399	5.318	5.647	5.663	5.490	5.608	5.556	5.585	5.415	5.643
2	5.300	5.285	5.323	5.540	5.480	5.639	5.724	5.278	5.344	5.400
3	5.570	5.499	5.491	5.263	5.341	5.511	5.670	5.485	5.654	5.610
4	5.312	5.666	5.281	5.637	5.487	5.584	5.710	5.398	5.641	5.374
5	5.299	5.372	5.653	5.337	5.432	5.265	5.512	5.550	5.405	5.369
6	5.333	5.335	5.455	5.373	5.464	5.704	5.303	5.386	5.684	5.503
7	5.456	5.388	5.367	5.305	5.531	5.428	5.414	5.317	5.527	5.526
8	5.711	5.651	5.573	5.276	5.250	5.532	5.291	5.677	5.418	5.705
9	5.590	5.679	5.463	5.506	5.259	5.258	5.282	5.719	5.419	5.691
10	5.301	5.454	5.433	5.404	5.600	5.553	5.519	5.387	5.385	5.575