

THESE DRAWINGS AND SPECIFICATIONS ARE THE PROPERTY OF ID SYSTEMS, INC., ARE ISSUED IN STRICT CONFIDENCE AND SHALL NOT BE DIVULGED, REPRODUCED, COPIED OR USED AS THE BASIS FOR THE MANUFACTURE OR SALE OF ANY ARTICLE WITHOUT WRITTEN PERMISSION

REVISIONS			
REV	DESCRIPTION	DATE	APP'D
01	ECN050281: PRELIMINARY ISSUANCE	4/20/07	\tmw

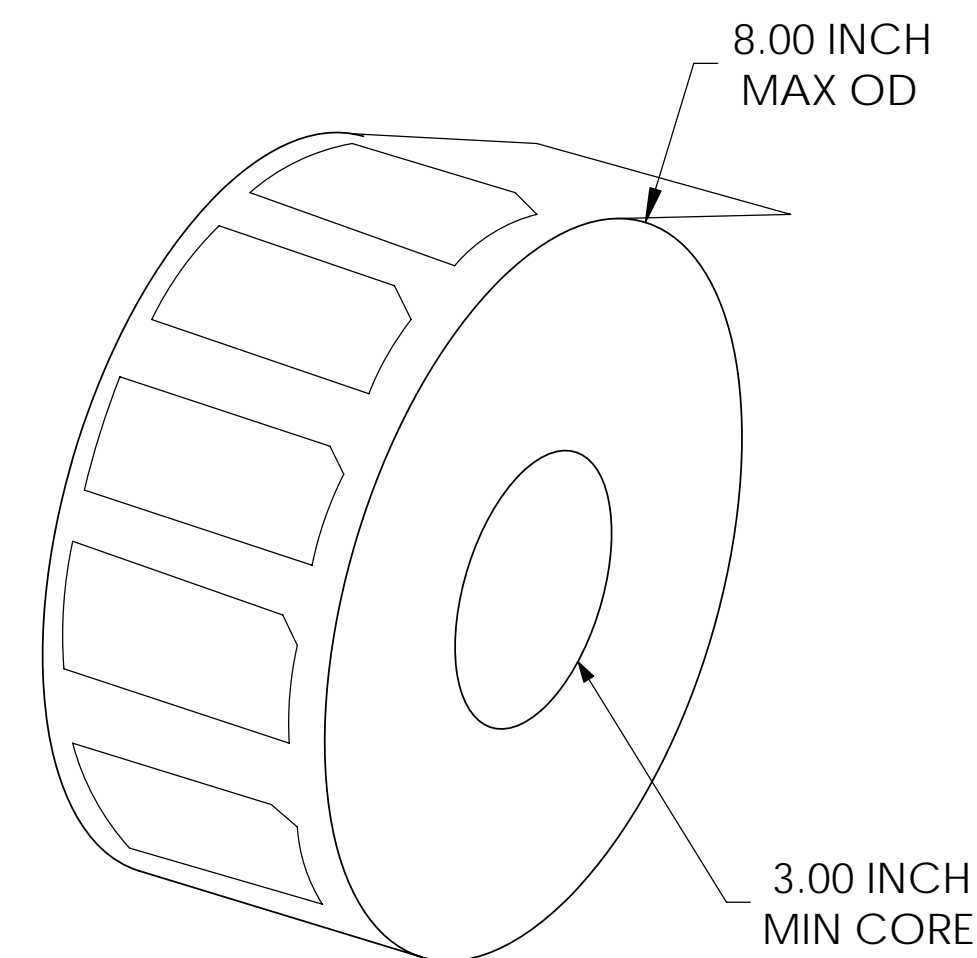
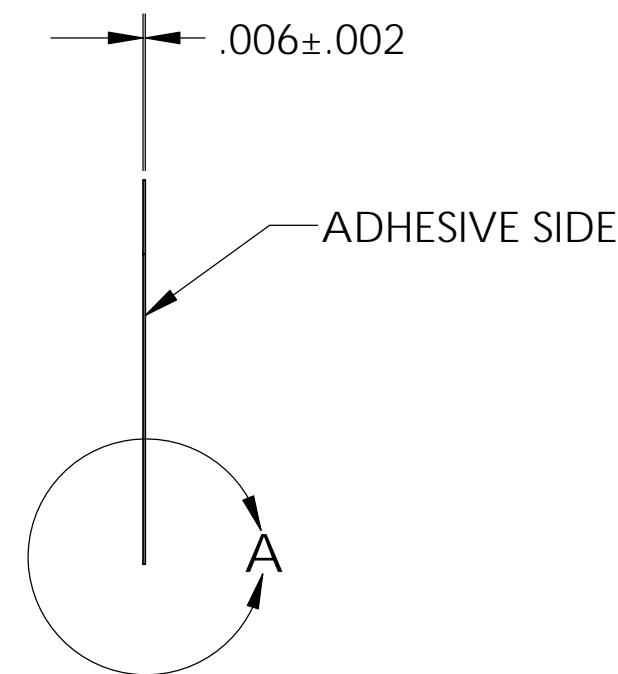
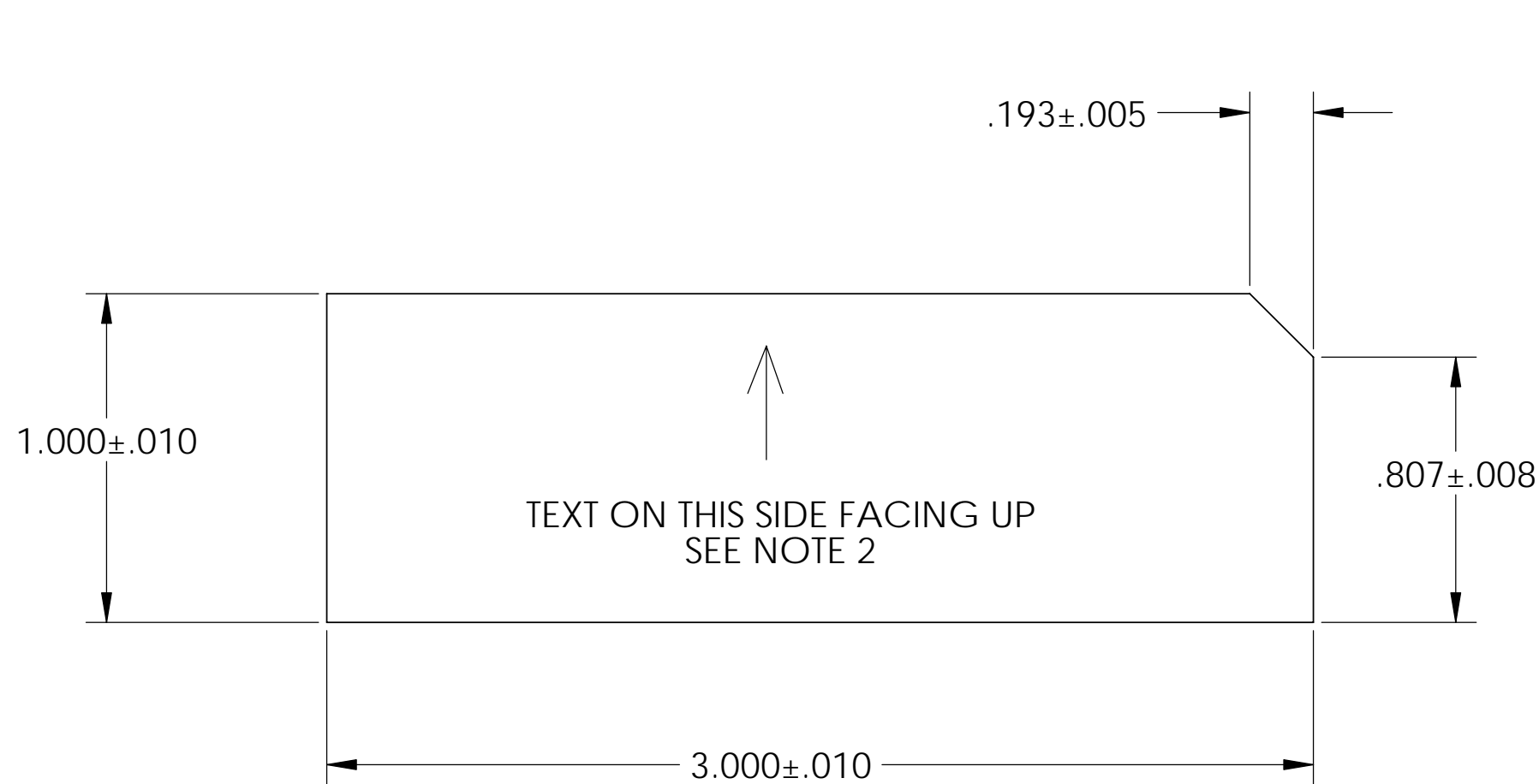

LABEL ROLL REFERENCE DATA

NOTES: UNLESS OTHERWISE SPECIFIED

- MATERIAL: 2 MIL MATTE CHROME POLYESTER TC WITH 2 MIL CLEAR OVERLAMINATE.
- LABEL ROLL TO INCLUDE PREPRINTED LABELS AS PER ARTWORK FILE ID SYSTEMS INC. PART NUMBER 010-00000089.
- PRINTER RIBBON: USE UL PURE RESIN RIBBON PART NUMBER LIMAK SP-330 TO PRINT MANUFACTURING SPECIFIC INFORMATION.
- LABEL SOLUTION SHALL BE A UL 969 MARKING AND LABELING SYSTEM.
- PACKAGE LABELS SUCH THAT THEY ARE NOT DAMAGED DURING SHIPPING & HANDLING. LABEL PACKAGING WITH ID SYSTEMS INC. P/N, REVISION AND QTY. OF LABELS PER ROLL.

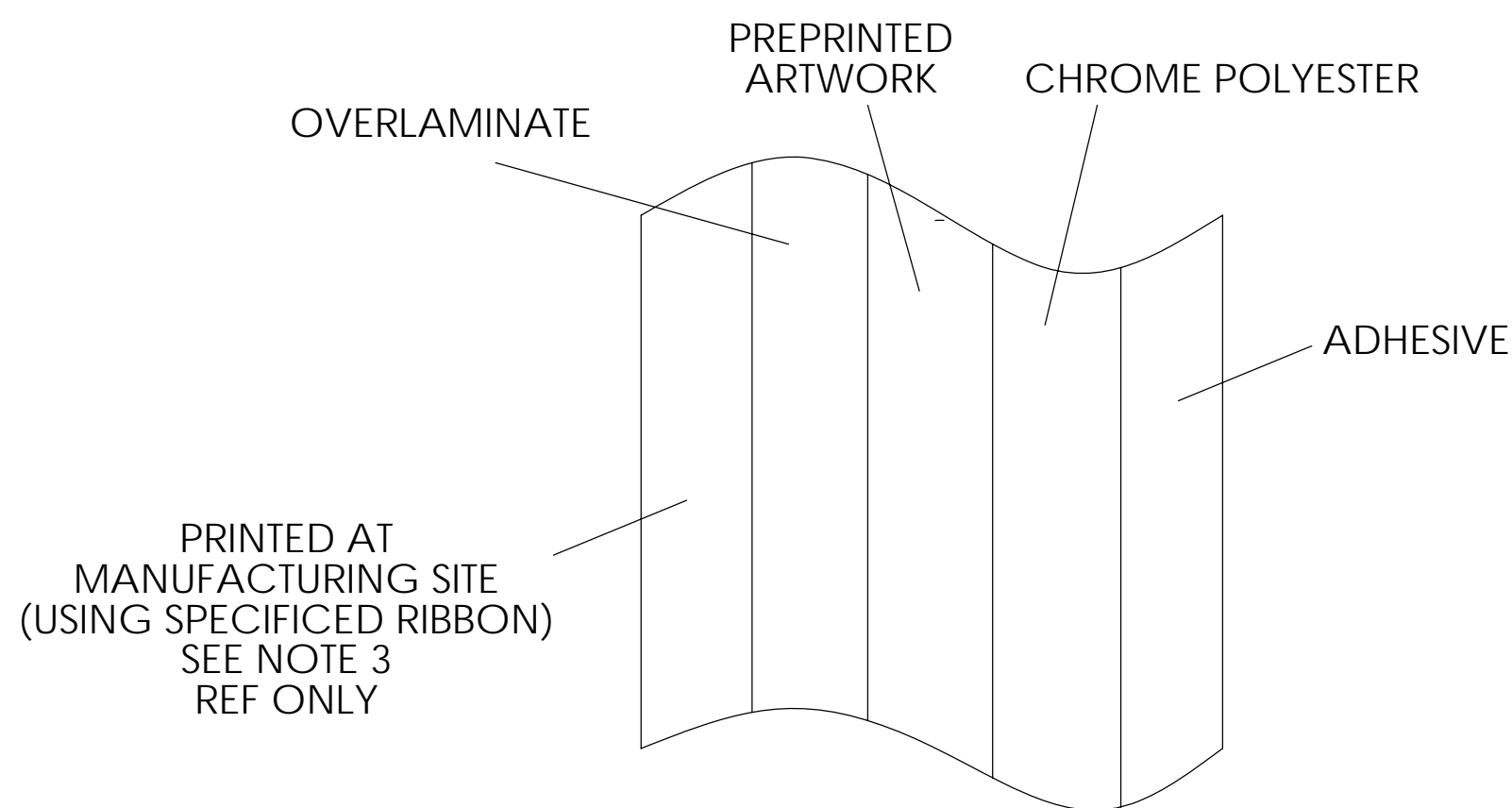

DETAIL A
LABEL CONSTRUCTION
SEE NOTE 1

DRAWN		V. YAKHNICH	4/20/07	ID Systems, Inc. 1 University Plaza, Hackensack, NJ 07601	
CHECKED		Tstrand	4/20/07		
QTY	NEXT ASSY	USED ON	APPR.		TMW
APPLICATION			APPR.	TITLE: LABEL, UNIT ID/FCC REGISTRATION, WIRELESS TRANSCEIVER ASSY	
MATERIAL			SEE NOTES 1 & 4		UNLESS OTHERWISE SPECIFIED: DIMENSIONS ARE IN INCHES TOLERANCES: FRACTIONAL ± 1/64 ANGULAR: MACH ± 1 DEG TWO PLACE DECIMAL ±.01 THREE PLACE DECIMAL ±.005
FINISH			N/A		
DO NOT SCALE DRAWING				SCALE: 4:1	FILENAME: 279-00000089_01.SLDDRW
SIZE	DWG. NO.	REV			
C	279-00000089	01	SHEET 1 OF 1		

2 Mil Matte Chrome Polyester

Spec# 11118

Facestock:

2 Mil Matte Chrome Polyester TC is a matte finished metallic film featuring excellent tear strength, heat resistance, dimensional stability, opacity and chemical resistance. Designed for printing with most solvent and some water-based flexographic inks. Suitable for thermal transfer printing applications with select thermal transfer ribbons. Specific testing required.

Caliper: 0.002 inches \pm 10%

Tensile: MD 18,000 psi
CD 18,000 psi

Adhesive:

Excellent, general purpose industrial grade clear adhesive. Features high initial tack, ultimate adhesion and low adhesive ooze.

Minimum Application Temperature: +25° F

Service Temperature Range: -40° F to 300° F (-40° C to 149° C)

Typical Performance Data:

Typical values, not for specification use (see attached Appendix 1 and 2).

Liner:

50# SCK is a bleached, super calendered paper stock with very good die-cutting and matrix stripping properties. Supplied with an Anti Block Coating on the backside of the liner to control adhesive and label transfer to the backside of the liner in finished, wound rolls. This liner should not be used in fanfolded label applications and is not recommended for back printability.

Basis Weight: 56.5# per ream \pm 10%
(24" X 36" 500 sheets)

Caliper: 0.0032 inches \pm 10%

Tensile: MD 51# per inch width
CD 23# per inch width

Tear: MD 56 grams per sheet
CD 71 grams per sheet

Total Construction Caliper (approximate): 0.0061 inches \pm 10%

Printing/Converting

The topcoat allows for printing by flexography without the need for specially formulated inks. However, testing is recommended prior to ink selection. This product can be die-cut and stripped at high speeds on standard web-fed presses. Sample labels in a variety of shapes have been dispensed and applied successfully with standard labeling systems.

Applications and Uses

This product is suitable for use in a wide range of durable labeling applications. This product is also UL recognized for indoor/outdoor service. See file #MH8212 and MH 17205 for specific details. Also recognized component of CSA (Canadian Standards Association).

Shelf Life

Unless specified otherwise in this document, one year when stored at 72°F at 50% RH

Statement of Practical Use

As with all pressure sensitive materials, this product should be tested thoroughly under end-use conditions to ensure it meets the requirements of the specific application.

Appendix 1:

Performance Data

2 Mil Matte Chrome Polyester TC

Spec# 11118

Note: The following technical data should be considered representative or typical only and should not be used for specification purposes.

Peel Adhesion: 180° and 90° peel test.

	Initial (15 minute dwell)				72 Hours at Room Temperature					
	90° Peel		180° Peel		90° Peel					
Surface:	oz/in	N/100mm	oz/in	N/100mm	oz/in	N/100mm	oz/in	N/100mm	oz/in	N/100mm
Stainless Steel	36.5	40.1	24	26.4	61.1	67.2	30.4	33.4		
Aluminum	40.5	44.5	20.8	22.8	75.4	82.9	32	35.2		
Enamel	32	35.2	19.2	21.1	30.4	33.4	25.6	28.2		
Polypropylene	15	15.8	6.4	7	27.2	29.9	13.8	15.1		
HDPE	17	18.7	9.6	10.6	22.2	24.5	17.3	19		
LDPE	1.9	2.1	1.6	1.8	7.5	8.3	3.2	3.5		
ABS	27.2	29.9	22.4	24.6	43.2	47.5	25.6	28.2		
Epoxy Powder Coat Aluminum										
	72 Hours				96 Hours					
	at 120° F					at 150° F (65° C) 80% Relative Humidity				
	180° Peel		90° Peel		180° Peel					
Surface:	oz/in	N/100mm	oz/in	N/100mm	oz/in	N/100mm				

Stainless Steel	75.6	82	54.4	59.8	48	52.8		
Aluminum	80.2	88.2	46.4	51	54.4	59.8		
Enamel	51.2	56.3	41.6	45.8	48	52.8		
Polypropylene	25.3	27.8	12.8	14.1	19.2	21.1		
HDPE	21.8	23.9	15.5	17.1	22.4	24.6		
LDPE	2.4	2.6	3.2	3.5	4.8	5.3		
ABS	20.8	22.9	17.6	19.4	32	35.2		
Epoxy Powder Coat Aluminum								

Liner Release:

90° removal of Liner from Facestock.

Loop Tack:

Rate of Removal	Grams/2" Width
400 inches/min.	80.16

	Loop Tack	
	oz/in	N/100mm
Stainless Steel	32	35

Appendix 2:

Environmental Performance Data

2 Mil Matte Chrome Polyester TC/

Spec# 11118

Chemical Resistance: The performance results are based on 4 hour immersions at room temperature unless otherwise noted (gasoline is 1 hour). Samples were applied to stainless steel panels and conditioned for 24 hours before immersion and evaluated immediately upon removal. Adhesion measured at 180° peel.

Chemical	Adhesion to Stainless Steel		Visual	Edge
	oz/in	N/100mm	Appearance	Penetration mm
Isopropyl Alcohol	30.4	33.4	No Change	0.89
Tide® Detergent	32.0	35.2	No Change	0.00
Engine Oil (10W30)	41.6	45.8	No Change	0.00
Water	38.4	42.2	No Change	0.00
Ammonia			Not Recommended	
409® Cleaner	22.4	24.6	No Change	0.00
Toluene	27.2	29.9	No Change	7.24
Brake Fluid	36.0	39.6	No Change	2.16
Gasoline	24.8	27.3	No Change	4.19
Kerosene K1	32.6	41.4	No Change	1.65
Heptane	30.4	33.4	No Change	2.03

409® is a registered trademark of the Clorox Company

Tide® is a registered trademark of the Procter & Gamble Company

Appendix 3:

Compliance Data

2 Mil Matte Chrome Polyester TC

Spec# 11118

UL - Underwriters Laboratories, Inc.

Substrates:	Minimum Temperature		Maximum Temperature		Indoor/Outdoor
	F°	C°	F°	C°	(I=Indoor only I/O=Indoor and Outdoor)
Aluminum	-40	-40	302	150	Yes
Stainless Steel	-40	-40	302	150	Yes
Galvanized Steel	-40	-40	302	150	Yes
Alkyd Enamel Painted Metal	-40	-40	212	100	Yes
Acrylic Painted Metal	-40	-40	302	150	Yes
Epoxy Paint	-40	-40	302	150	Yes
Polyester Paint	-40	-40	212	100	Yes
Nylon	-40	-40	212	100	Yes
Phenolic	-40	-40	212	100	
ABS Plastic	-40	-40	176	80	
Polypropylene Oxide	-40	-40	176	80	
Polycarbonate	-40	-40	176	80	Yes
Polystyrene	-20	-29	176	80	
Thermoset Polyester	-40	-40	212	100	

Recognized Ribbons:		
Armor "AXR7+"		Yes
Astro Med Inc "R-5"		Yes
NCR "Promark 3"		Yes
Dai Nippon "R-300"		Yes
Iimak "SP-330"		Yes
Japan Pulp & Paper "Resin 1"		Yes
Peak "Ultra Premium"		Yes
Ricoh "XB110C"		Yes
Sato Corp. "Premier 1"		Yes
Sony "4072" "4571" "5070"		Yes
Union Chemicar "US-300"		Yes
Zebra "5095" "5175"		Yes
Ricoh "XB110CR"		Yes

2 Mil Matte Chrome Polyester TC

Spec# 11118

CSA - Canadian Standards Association

Substrates:	Minimum Temperature		Maximum Temperature		Indoor/Outdoor
	F°	C°	F°	C°	(I=Indoor only I/O=Indoor and Outdoor)
Metals	-40	-40	302	150	Yes

PARTY FOR INDIRECT, CONSEQUENTIAL, INCIDENTAL, SPECIAL OR PUNITIVE DAMAGES.

No representative or agent of DLS is authorized to give any guarantee or warranty or make any representation contrary to the above. No waiver, alteration, addition or modification of the foregoing conditions shall be valid unless made in writing and signed by an executive officer of DLS.