

Operating instructions

DRC-J joystick control system

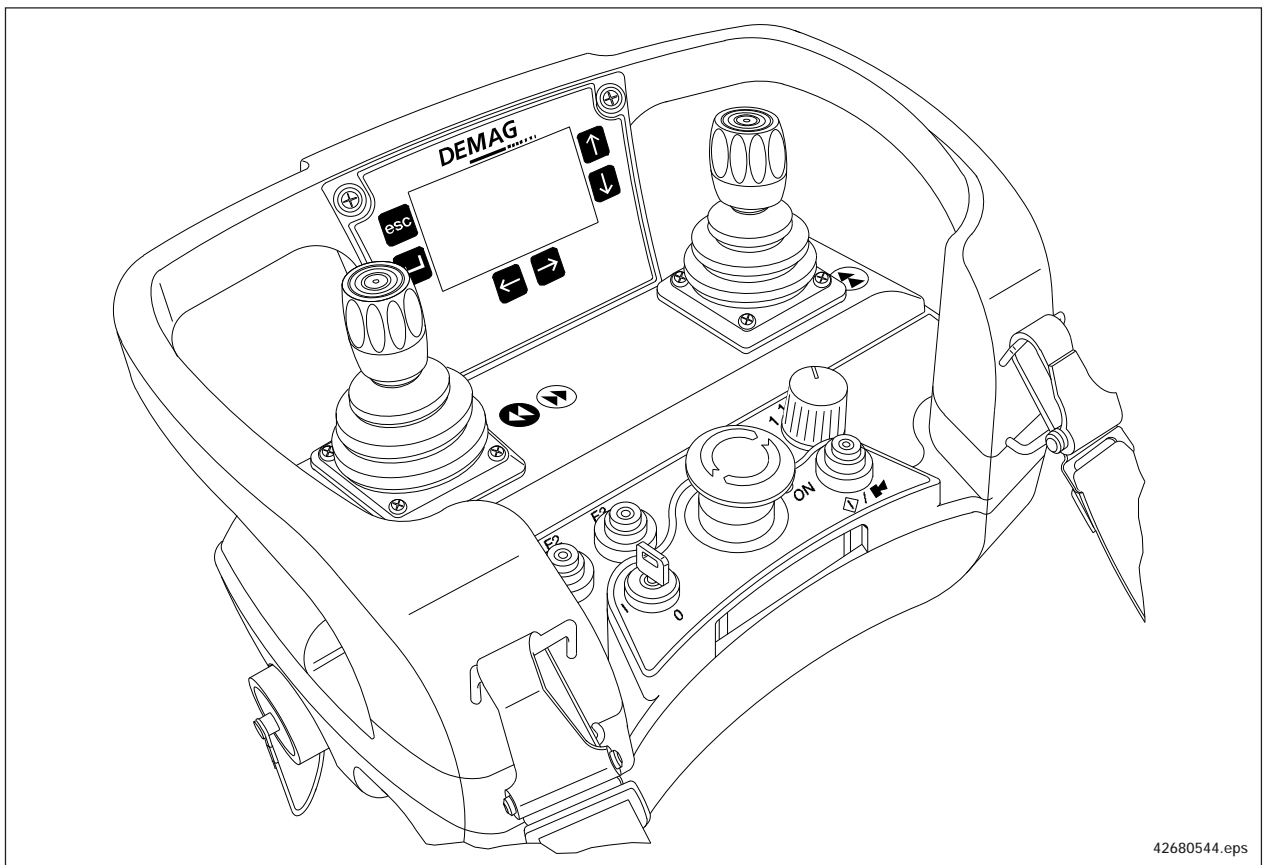

42680544.eps

Contents

	Page
1 Foreword	4
1.1 Copyright	4
1.2 Customer service	4
1.3 Liability for Defects	5
1.4 Limitations of liability	5
1.5 Definitions	6
2 Safety instructions	7
2.1 Symbols	7
2.2 Appropriate use	7
2.3 Inappropriate use	9
2.4 Basic information on safety	9
2.5 Safety instructions for installation and disassembly	10
2.6 Safety instructions when first putting into service after completing installation	11
2.7 Safety instructions for operation	11
3 General description	12
3.1 Transmitter/receiver interface	12
3.2 Transmission method	12
4 Selection of unit	14
4.1 DRC-J scope of delivery	14
4.2 Available radio receivers	14
4.3 Accessories for crane identification	14
4.4 Casing seal/seal breakage	14
5 Identification and display functions	15
5.1 Joystick control unit	15
5.2 LCD display	16
5.3 Identification labels for the crane installation	20
6 Putting the radio control system into operation after installation	22
6.1 Putting into operation	22
6.2 Putting a radio remote control system with DRC-J into operation	23
6.3 Configuration of a radio remote control system for DRC-DR	28
7 Operation of the radio control system	29
7.1 Checks before starting work	29
7.2 Crane operation/Run	31
7.3 Taking out of service at the end of the shift	33
7.4 Operating statuses of the radio control system	33
8 Joystick control unit power supply	35
8.1 General description	35
8.2 Display of available battery capacity	36
8.3 Charging the batteries	36
8.4 Replacing the batteries	37

	Page
9 Information menu in connection with DRC-DR	38
9.1 Activating the Information menu	38
9.2 Selecting the information source	38
9.3 Starting screen	38
9.4 Navigating in the information menu	38
9.5 Data of the Information menu	39
10 Technical data	40
10.1 Dimensions	40
10.2 International postal registration	41
11 Eliminating faults	42
EC conformity declaration	44
DRC-J joystick control system parameter programming (For authorized personnel only)	45
1 Menu for programming parameters of the joystick control system	46
1.1 Activating the menu	46
1.2 Displaying the current parameters	46
1.3 Displaying the serial number of the joystick control system Parameter code 001	46
1.4 Displaying the software version of the joystick control system Parameter code 002	47
1.5 Displaying the hardware version of the joystick control system Parameter code 003	47
1.6 Displaying and entering a fixed frequency channel, Parameter code 004	47
1.7 Displaying and entering the cut-out time in STOP mode, Parameter code 005	48
1.8 Displaying and entering the cut-out time in Run mode, Parameter code 006	49
1.9 Frequency hopping	50

Accompanying documents:

DRC-MP operating instructions	214 994 44	720 IS 975
DRC-DR operating instructions	214 953 44	720 IS 975 3

1 Foreword

You have purchased a Demag product/system.

These operating instructions are designed to provide the owner with appropriate instructions for safe and correct operation and to facilitate maintenance.

Every individual given the task of transporting, installing, commissioning, operating, maintaining and repairing our products and systems must have read and understood

- the operating instructions
- the safety regulations and
- the safety instructions in the individual chapters and sections.

The operating instructions must be available to the operating personnel at all times in order to prevent operating errors and to ensure smooth and trouble-free operation of our products/systems.

1.1 Copyright

These operating instructions must be treated confidentially. They should only be used by authorized personnel. They may only be entrusted or made available to third parties with the prior written consent of Demag.

All documents are protected within the sense of copyright law.

No part of this documentation may be reproduced, utilized or transmitted without specific prior consent. Infringements are an offence resulting in obligatory compensatory damages.

All industrial rights reserved.

1.2 Customer service

Our after-sales service will provide you with all technical information on Demag products and their systematic application.

Should you have any questions regarding our products, please refer to one of our after-sales service stations, the relevant representative or the manufacturer.

Kindly quote the serial or order number (see test and inspection booklet, load capacity plate on the crane) in any correspondence or for spare part orders.

Specifying this data ensures that you receive the correct information or the required spare parts.

1.3 Liability for Defects

These operating instructions must be read carefully before installing and putting the system into operation.

We assume no liability for any damage and malfunctions resulting from failure to comply with the operating instructions.

Any liability claims for defects must be made by quoting the order number immediately on detecting the defect.

Any liability claims for defects are void in the event of:

- inappropriate use,
- faulty devices or equipment connected or attached to the system which are not part of our scope of supplies and services,
- use of non-genuine spare parts and accessories,
- refurbishment or modification of the product unless approved in writing by Demag.

Wearing parts are not subject to liability for defects.

1.4 Limitations of liability

All technical information, data and instructions for operation contained in these operating instructions were up-to-date on going to print and are compiled on the basis of our experience and to the best of our knowledge.

We reserve the right to incorporate technical modifications within the scope of further development of the system which is the subject of these operating instructions.

Therefore, no claims can be derived from the information, illustrations and descriptions contained in these operating instructions.

The descriptions and illustrations contained in this documentation do not necessarily correspond to the scope of delivery or any subsequent spare part delivery, either; the drawings and illustrations are not to scale.

Only documentation belonging to the actual order is valid.

We assume no liability for damage and malfunctions caused as a result of operating errors, non-compliance with these operating instructions or inappropriate repairs and maintenance.

We expressly point out that only genuine Demag spare parts and accessories approved by us may be used. Accordingly, this also applies to other manufacturers' parts supplied by us.

For safety reasons, the fitting and use of spare parts or accessories which have not been approved and unauthorized modification and conversion of the product are not permitted and exempt us from any liability for damages resulting therefrom. With the exclusion of any further claims, we are liable for any defects or omissions on our part in the products or documentation supplied within the scope of the liability obligations entered into in the original contract. Any further claims, in particular any and all claims for damages, are excluded with the exception of legal claims in accordance with product liability legislation.

1.5 Definitions

Owner

Owners (employer, company) are defined as a person who owns such a system and who uses it appropriately or allows it to be operated by suitable and instructed persons.

Operating personnel/operator

Operating personnel or operators are defined as persons entrusted by the owner of the system with the operation of the system.

Specialist personnel

Specialist personnel are defined as persons assigned by the owner of the system to carry out special tasks such as installation, setting-up, maintenance and fault elimination.

Qualified electrician

Qualified electricians are defined as persons who, owing to their technical training, knowledge and experience of electrical installations as well as knowledge of the relevant standards, codes of practice and regulations, are able to assess the tasks given to them and to identify and eliminate potential hazards.

Trained person

Trained persons are defined as persons who have been instructed and trained for the tasks assigned to them and on the possible hazards resulting from incorrect handling and who have been informed about the required protective devices, protective measures, relevant regulations, codes of practice, accident prevention regulations and operating conditions and who have proven their qualifications.

Experienced technician

Experienced technicians are defined as persons, who, owing to their technical training and experience, have sufficient knowledge of these systems and are familiar with the relevant national industrial safety regulations, codes of practice, accident prevention regulations, directives and generally accepted engineering standards enabling them to judge the safe operating condition of such systems.

2 Safety instructions

2.1 Symbols

These symbols are used to warn against potential safety hazards or causes of damage or provide useful information.



Hazard warning

This symbol appears in the operating instructions next to all instructions relating to safety at work wherever a potential danger to life and limb exists.

Follow these instructions at all times and be particularly vigilant and cautious.

Pass on safety instructions to all persons entrusted with working on the product including the power supply.

In addition, observe all general safety regulations at all times.



Warning against dangerous electrical voltage

Contact with live parts can result in immediate death. Protective covers (e.g. covers and enclosures) marked with this sign may only be opened by qualified electricians. Before opening, all relevant operating, control, feed or other voltages must be disconnected.



Operating hazard for the installation

This symbol in the operating instructions indicates all warnings which, if not complied with, may result in damage to the product.

2.2 Appropriate use

The DRC-J joystick control system is intended to be used as an operating unit and transmitter station for the DRC-DR and DRC-MP radio receivers. The scope of functions is preferably designed for wireless control of crane installations, travelling hoist units, chain and rope hoists, transfer carriages and similar applications.

The operator can position himself as required. He can control loads and movements from a safe distance. He must always select a location to ensure that all movements of the load and the crane can be monitored and any hazardous movement can be switched off within an appropriate time. Before starting a crane movement by actuating the operating element, the operator must determine which crane is being controlled. The display of the DRC-J joystick control unit shows the identification/crane number of the controlled crane. The radio-controlled crane must be identified by means of the identification/crane number in a way clearly visible to the operator.

If required, a signal must be actuated prior to a crane movement for acoustic control.

DRC transmitters and receivers meet the requirements of the standards and regulations listed in the EC conformity declaration. The specified EC conformity declaration is an integral part of the relevant operating instructions.

Transmitters and receivers of the DRC range can be operated without any registration or operating fee. The benefits that this provides for the user are also utilised by some other manufacturers of devices for communications and telemetry applications. The consequence of this is that the relevant approved frequency ranges may be used by many transmitters at the same time, depending on the time and location.

The transmission method used by Demag is designed for the most robust and interference-resistant radio transmission between the transmitters and receivers of the DRC range.

The state-of-the-art transmission method is provided with technical features (e.g. frequency hopping) which are intended to ensure a minimum of conflicts for radio operation together with other transmitter and receiver devices which use the same frequency range.

Despite all of the technical precautions taken by Demag, it cannot be entirely excluded that the transmission characteristics of other radio systems are impaired, in particular devices supplied by other manufacturers that use the same frequency range, or that the transmission characteristics of the system supplied by Demag are negatively affected. In such cases, interference or radio connection interruptions may occur, which disrupt the communication and function of a system supplied by Demag or other manufacturers. Such impairment or interference does not constitute a defect on the part of DRC transmitters and receivers. Demag will only accept liability for wilful or grossly negligent behaviour on its part.

The number of transmitters that operate without any interference in a given area depends on the relevant radio solution design of all systems and the selectivity of each individual system.

If this limit is exceeded continuously or for certain periods, additional technical measures may be necessary in order to ensure simultaneous and interference-free operation of the radio systems. Whether and to which extent such measures are required can only be determined by means of suitable measurements on site or when the system is put into operation. Demag is not responsible for such additional technical measures.

Radio remote control systems of the DRC range are exclusively intended for single-transmitter operation; i.e. there is always a clear assignment between a specific transmitter and the corresponding receiver.

The DRC-J joystick control system may only be operated when in perfect working order by trained personnel in accordance with the relevant safety and accident prevention regulations. This also includes compliance with operating and maintenance conditions specified in the operating instructions.

In Germany, the owner of a crane installation with radio control system is responsible for compliance with accident prevention regulations BGV D6.

DRC-J joystick control units that are ready for operation must not be left unattended. They must be protected against unauthorized use.

For appropriate use, the information in the operating instructions for the receiver used (DRC-DR/DRC-MP) and the machine/crane installation to be controlled must be complied with in addition to the information contained in these operating instructions.

Serious personal injury or damage to property may occur in the event of:

- unauthorized removal of covers,
- inappropriate use of the product/system,
- incorrect operation,
- insufficient maintenance,
- working on live parts.

2.3 Inappropriate use

Certain work and practices are prohibited when using the system as they may involve danger to life and limb and result in lasting damage to the product, e.g.:

- Manipulating electrical equipment
- Connecting the unit to power supply with voltage or frequency other than those specified on the type plate
- Non-compliance with specified mounting positions
- Non-compliance with the max. permissible operating temperature.

Other inappropriate applications may be caused by non-compliance with the information in the operating instructions for the radios receiver used (DRC-DR/ DRC-MP) or for the machine to be controlled.

2.4 Basic information on safety

Persons under the influence of drugs, alcohol or medicines which affect reactions must not install, operate, put into service, maintain, repair or disassemble the product. Any conversions and modifications to the installation must comply with the safety requirements. Work on electrical equipment may only be carried out by specialists in accordance with electrical regulations.

In the event of malfunctions, the system must be shutdown, switched off and the relevant main switches locked immediately.

Malfunctions must be eliminated immediately.

National accident prevention regulations and codes of practice and general safety regulations must be observed when operating our products. Important information and instructions are marked by corresponding symbols. Follow these operating and safety instructions to avoid personal injury and damage to machinery.

The operating instructions must be kept available at the place where the system is in use at all times.

They include significant aspects and appropriate excerpts from the relevant guidelines, standards and regulations. The owner must instruct his personnel appropriately. If the safety instructions given are not observed in any way, personal injury or even death can result.

Observe general statutory and other obligatory regulations relating to accident prevention and environmental protection and basic health and safety requirements in addition to those included in these operating instructions.

Such requirements may also relate, for example, to the handling of hazardous materials or the provision/wearing of personal protection equipment.

Comply with these regulations and general accident regulations relevant for the place at which the system is used and follow the instructions therein when working with the system.

The system may still constitute a danger to life and limb if it is not installed, operated, maintained or used appropriately by personnel which have not been trained or specially instructed.

The safety instructions must, if required, be supplemented by the owner with instructions and information (e.g. factory regulations) relating to organization of work, working procedures, operating personnel, etc. Supervising and reporting obligations as well as special operating conditions must also be taken into consideration. Supervising and reporting obligations as well as special operating conditions must also be taken into consideration.

Personnel assigned to working with the system must have read the operating instructions and the safety instructions.

All activities relating to the system which are not described in the operating instructions may only be carried out by specifically trained specialist personnel.

The owner must ensure that personnel work in a safety and hazard-conscious manner in compliance with the operating instructions.

The owner must ensure that the system is only operated when in proper working order and that all relevant safety requirements and regulations are complied with.

The system must be taken out of service immediately if functional defects or irregularities are detected.

In the event of a stoppage (e.g. if defects regarding safe and reliable operation are detected, in emergency situations, in the event of operating malfunctions, for maintenance purposes, if damage is detected or after finishing work), the operator/experienced technician must carry out all prescribed safety measures or observe that they are automatically carried out.

Personal protective clothing must be worn as necessary or as required by regulations. Personnel must not wear loose clothing, jewellery including rings or long hair loose. Injury may occur, for example, by being caught or drawn into the mechanism.

All safety and hazard warnings on the product, its access routes and mains connection switches must be preserved completely and in legible condition.

Modifications, additions to and conversions of the product which might impair safety in any way must not be carried out without the approval of Demag.

Safety devices must not be rendered inoperative.

Only genuine Demag spare parts may be used. Observe prescribed deadlines or those specified in the operating instructions for routine checks/inspections.

2.5 Safety instructions for installation and disassembly

- Installation and disassembly work may only be performed by experienced technicians.
- Installation and disassembly work must be co-ordinated by the person carrying out the work and the owner within the scope of their responsibility.
- The assembly zone must be made safe.
- The installation must be isolated in accordance with the relevant electrical regulations.
- Customer-specific regulations must be observed.
- Only appropriate, tested and calibrated tools may be used.

In the case of disassembly, any waste material must be disposed of by the owner in an environmentally compatible way in compliance with the valid regulations.

2.6 Safety instructions when first putting the unit into service after completing installation

- The working area must be made safe.
- First check that the voltage and frequency specified on the type plates match the owner's mains power supply.
- In the course of putting the product into service, it may be necessary to render safety devices or features inoperative when carrying out adjustments or function checks.
- When putting the machine into service, it may be necessary to perform work in the danger zone, therefore, it must be ensured that only appropriately trained personnel are employed for this work.

2.7 Safety instructions for operation

Before putting the crane into operation, the operating personnel must be satisfied that the radio control system is in safe and correct operating condition.

In addition, the safety instructions and measures contained in the operating instructions of the crane must be applied.

The clear assignment between the DRC-J joystick control system to the radio receiver (DRC-DR/DRC-MP) on the crane is the precondition for safe wireless remote control of a crane. This unique assignment is created by the exchange of the address features between transmitter and receiver when a DRC-J joystick control system is put into operation. The operating personnel recognises which crane is controlled by means of the crane identification shown in the display of the joystick control unit.

Before switching on/putting into operation of the crane/machine controlled by the radio control system with the DRC-J joystick control system, it must be ensured that nobody is endangered by operation of this crane.

If the operator notices persons who may be exposed to a risk to health or personal safety by operation of the equipment, he must suspend operation immediately and may not resume operation again until the persons are outside the danger zone.

STOP key function

Actuation of the red STOP key activates the emergency-stop function in the radio receiver on the crane. The emergency-stop function stops any potentially dangerous movement of the crane. For use of the emergency-stop function, in particular the instructions contained in the operating instructions of the crane must be complied with. When the STOP key has been actuated, the radio system is in the "STOP" operating mode. No movement commands are transmitted. The STOP key latches when actuated. To quit the EMERGENCY stop function, first turn the STOP key to unlock it and then actuate the Start/Horn key. This may only be done after the operator has made sure that the hazardous situation which resulted in actuation of the STOP key has been eliminated.

Warning device function

Radio-controlled cranes must be provided with a warning device (acoustic or optical). The crane operator can activate this warning device by means of the horn key to warn persons in the vicinity of the crane and/or load before starting the crane movements. The warning device must also be used if the crane operator intends to check the assignment between the joystick control unit and the crane receiver by means of a joystick control command.

Range of the radio remote control system

The crane operator may only use the range of the radio control system to the extent that he can freely monitor the danger zone of the crane movements.

The range of the hand-held radio transmitter is limited and can be additionally reduced by ambient conditions. The range may also be limited by utilization of the available frequency range by other radio transmitters. The quality of the radio signal is shown in the display of the joystick control unit. If poor connection quality is displayed, unintended interruptions of the controlled movements may occur.

3 General description

3.1 Transmitter/receiver interface

Demag DRC radio control systems are designed for wireless control of hoist units and cranes. They are the interface for manually controlled crane installations. The applicable EC directives and standards are complied with for this application. Demag DRC radio control systems consist of a radio transmitter/operating unit and a radio receiver with interface to the crane control system. DRC-J joystick control systems in applications in connection with DRC-DR or DRC-MP radio receivers are the subject of these operating instructions.

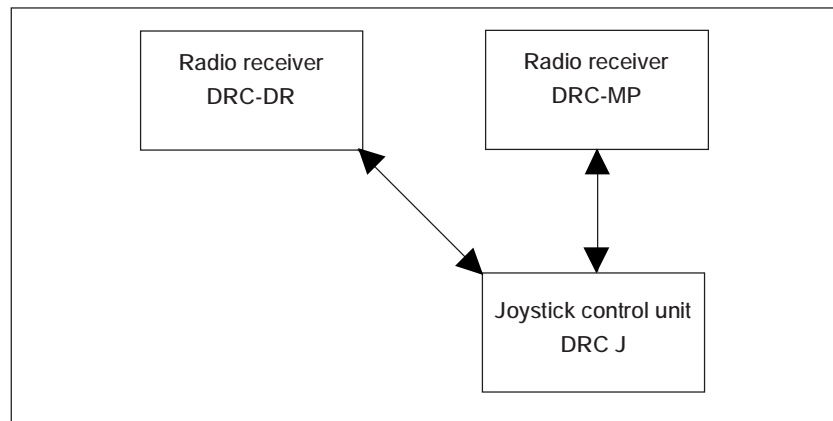

- The Demag DRC-DR radio receiver is a pluggable PCB for installation in the electrical equipment cover of the DR hoist unit. The interface of this receiver component to the crane control system and power supply by the DR electrical equipment is the CAN safety bus. The DRC-DR radio receiver is exclusively suitable for operation with a DR hoist unit.
- The Demag DRC-MP radio receiver is a complete unit with its own enclosure and power supply from the control voltage network of the crane installation. Relay contacts for the individual control commands and the EMERGENCY stop circuit form the interface of this unit to the crane control system. An additional semiconductor output with pulse width modulation is provided for infinitely variable crane drives. The DRC-MP radio receiver is suitable for a wide range of applications.

Demag radio receivers are provided for duplex operation and transmit information to the DRC-J joystick control system. This increases safety of the radio system. Status information of the crane control system and the receiver are shown in the display of the DRC-J joystick control unit.

3.2 Transmission method

The so-called ISM band (433 MHz) is used for transmitting the radio signals between transmitter and receiver. Within the ISM band 30 frequencies are used alternately in a defined sequence (so-called frequency hopping). A random-check generator determines the sequence of the frequencies when radio transmission is started. In order to increase transmission reliability, the information is transmitted several times. This method in connection with frequency hopping provides for a very high immunity to interference.

Frequency hopping is used for the first time with Demag DRC radio control system types D1-FH and D2. In the case of the D1 type, the frequency of the radio signal is not changed during a transmission cycle.

A decisive advantage of the frequency hopping transmission is that existing information contents are transmitted on several physical channels. This redundant radio transmission 1) provides for an exceptionally high insensitivity of radio transmission against other transmitters or electromagnetic interference.

1) Certain information contents are transmitted on up to 5 different frequencies. Only if (theoretically) all frequencies used were occupied or disturbed by other radio systems, communication would be interrupted.

3.2.1 Downwards compatibility of DRC-10 D2 transmitters

For combining DRC-10 D2 transmitters with D1 type receivers
 DRC-DR, part no. 719 441 45
 DRC-MP, part no. 773 432 44
 these transmitters must be programmed for operation at a fixed frequency (chapter „Programming parameters of the DRC-10 handheld transmitter“, section 1.6).
 The table below shows an overview of the possible combinations

3.2.2 Compatibility D1, D1 FH and D2

Transmitter	Design	Product Part no.:	Receiver				
			D1 DRC-MP 773 432 44	D1 DRC-DR 719 441 45	D1 FH DRC-Mp 773 584 44	D1 FH DRC-DR 719 436 45	D2 DRC-DR 719 439 45
Transmitter	D1	DRC-10 773 431 44	OK	OK	not compatible	not compatible	not compatible
	D1	DRC-J 773 460 44	OK	OK	not compatible	not compatible	not compatible
	D1 FH	DRC-10 773 581 44	Fixed frequency	Fixed frequency	OK	OK	OK
	D1 FH	DRC-J 773 583 44	Fixed frequency	Fixed frequency	OK	OK	OK
	D2	DRC-10 773 591 44	Fixed frequency	Fixed frequency	OK	OK	OK

Explanation:

- D1 without frequency hopping
- D1 FH with frequency hopping
- D2 with frequency hopping and, if required, with extended functions

3.2.3 Frequency hopping feature

Transmitters and receiver with frequency hopping can be identified by the part no. on the rating plate.
 Additionally transmitters with frequency hopping have a different symbol for the signal strength in the display.

Transmitter without frequency hopping

Transmitter with frequency hopping

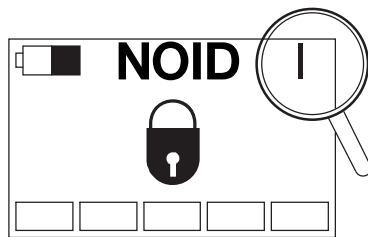

42718344.eps

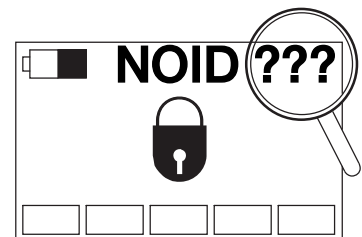

42718244.eps

4 Selection of unit

4.1	DRC-J scope of delivery		Part no.: 773 583 44
		DRC-J D1 FH joystick control system set	
		Contents of the complete delivery	
		1 DRC-J D1 FH joystick control unit	
		1 Rechargeable battery 1)	NiMH 7,2 V 773 462 44
		1 Battery charger	230 VAC 50 Hz 250 mA 773 463 44
		1 Shoulder strap	773 461 44
		1 Operating instructions	DRC-J joystick control system 214 974 44
		1 Key symbols for transmitter	DRC J 773 439 44
4.2	Available radio receivers	DRC-DR D2 radio receiver	719 439 45
		DRC-MP D1 FH radio receiver	773 584 44
4.3	Accessories for crane identification	Coding labels	Carrier foil, black 895 639 44
		Coding labels	7 segments (yellow) 895 640 44
		Travel direction foil cross travel	895 635 44
		Travel direction foil long travel	895 637 44
		Aerial for DR 3, 5, 10, 20	(433 MHz ISM band) 719 445 33
			Patch aerial for 433 - 434 MHz.frequency range. Installed on DR electrical equipment cover.
			For installation refer to 203 638 44

Note:

For application of the DRC-J radio remote control system in crane installations, the owner must observe the regulations and instructions of the BGV D6.

All components are designed for operation in industrial environments.

The DRC-J joystick control system has been built in compliance with the regulations and rules of the BGV D6 for cranes, the ZH 1/547 guidelines for radio remote control systems of cranes and the EN 60204-32 as well as the EN 954-1.

All units have been tested in accordance with the EMC directives and comply with the relevant standards regarding interference emission and resistance to interference for application in industrial environments.

To comply with the EMC requirements, the following points must be considered for integration into overall systems:

- Integration of electronic components to meet EMC requirements
- Use of prescribed or approved cables, screened cables, if required.

4.4 Casing seal/seal breakage



The DRC-J joystick control system is sealed in the factory.

The equipment, and particularly the joystick control unit, may only be opened for repair purposes by authorised parties.

Breaking of a casing seal such as this will result in loss of all warranty rights!

1) Service life of the rechargeable battery in charging cycles to IEC 61951, more than 500 charging cycles

5 Identification and display functions

5.1 Joystick control unit

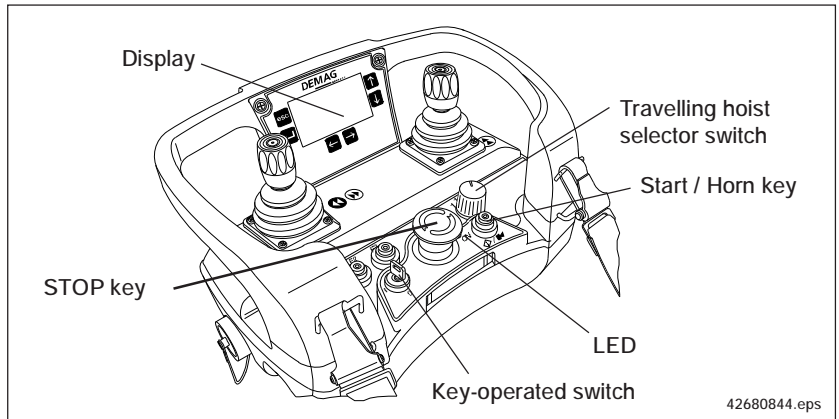

The LED in the joystick control system indicates the operating status of the joystick control system:

LED	Operating status
LED off	The joystick control system is switched off or in standby mode
LED lit red	The joystick control system is in STOP mode
LED flashes green	The joystick control system is in operating mode

Key designation

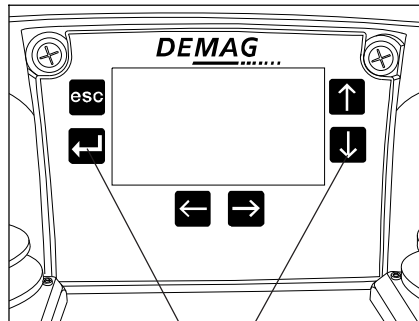

Key Symbol	Key Designation
Esc	Cancel
→	Right
←	Left
↑	Up
↓	Down
↵	Return

42680944.eps

Yellow symbol against black background

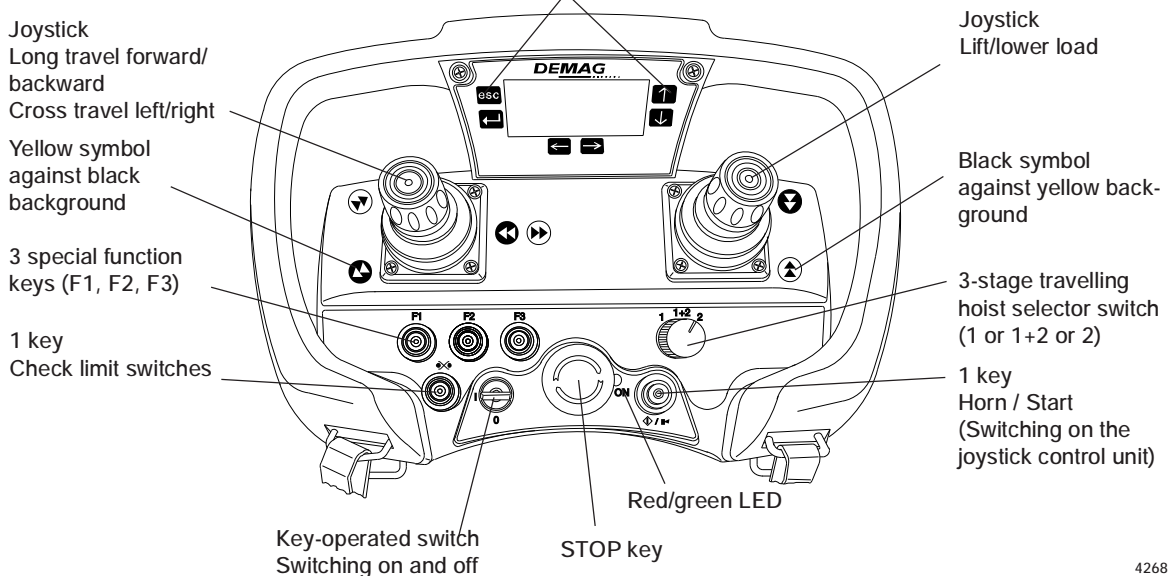

21497544.indd/311007

42684444.eps

5.2 LCD display

The joystick control unit is provided with a display. In the display, all data important for operation of the crane to be operated are shown.

The number of information items displayed varies depending on the type of receiver. The scope of display functions comprises the general displays which are available for both receiver types and additional information that can only be used with DRC-DR receivers.

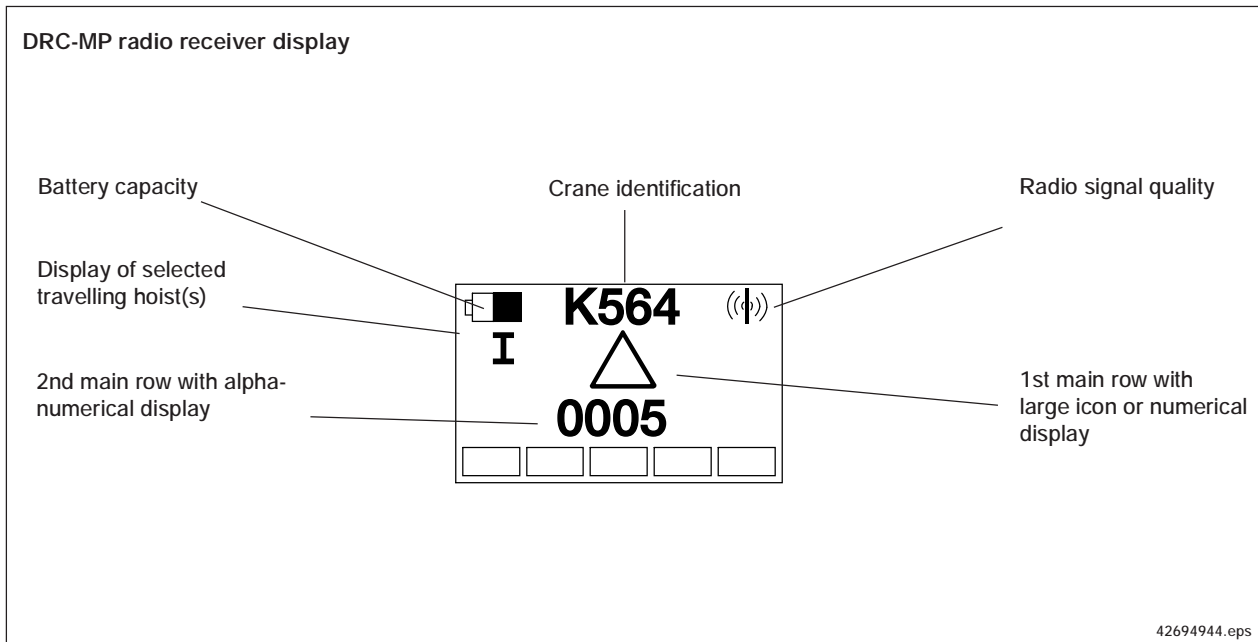

5.2.1 General display

Crane identification K564

The crane identification shows to which crane the joystick control unit has been assigned. It is saved in the radio receiver and it can only be entered via the joystick control unit.

Display of selected travelling hoist(s)

The display of the selected travelling hoists is only active, if there are two travelling hoists and both can be operated with one radio control system.

Symbol	Meaning
I	Travelling hoist 1 is selected
II	Travelling hoist 2 is selected
I+II	Travelling hoists 1 and 2 are selected

Display of radio connection quality

Signal strength icon

42680944.eps 42696144.eps

Symbol	Meaning
((Φ))	Full signal strength
(Φ)	50 % of max. range between transmitter and receiver reached
Φ	Weak signal: If the distance between the transmitter and the receiver is further increased, the radio connection may be interrupted



Battery icon

The battery icon indicates the status of the rechargeable batteries.

Icons in the first main row

In the first main row, all icons important for operation are shown.



Lock icon

The lock icon indicates the standby mode. An electronic On key must be entered to switch the unit on.



STOP icon

STOP indicates the STOP mode. The system switches over to Run mode with the electronic key.



"No radio connection" icon

The "No radio connection" icon is displayed, if the joystick control unit failed to establish a connection to the assigned radio receiver.

Warning icon



The warning icon is displayed in the event of a warning. The code of the warning is displayed in the row below.

5.2.2 Additional display information

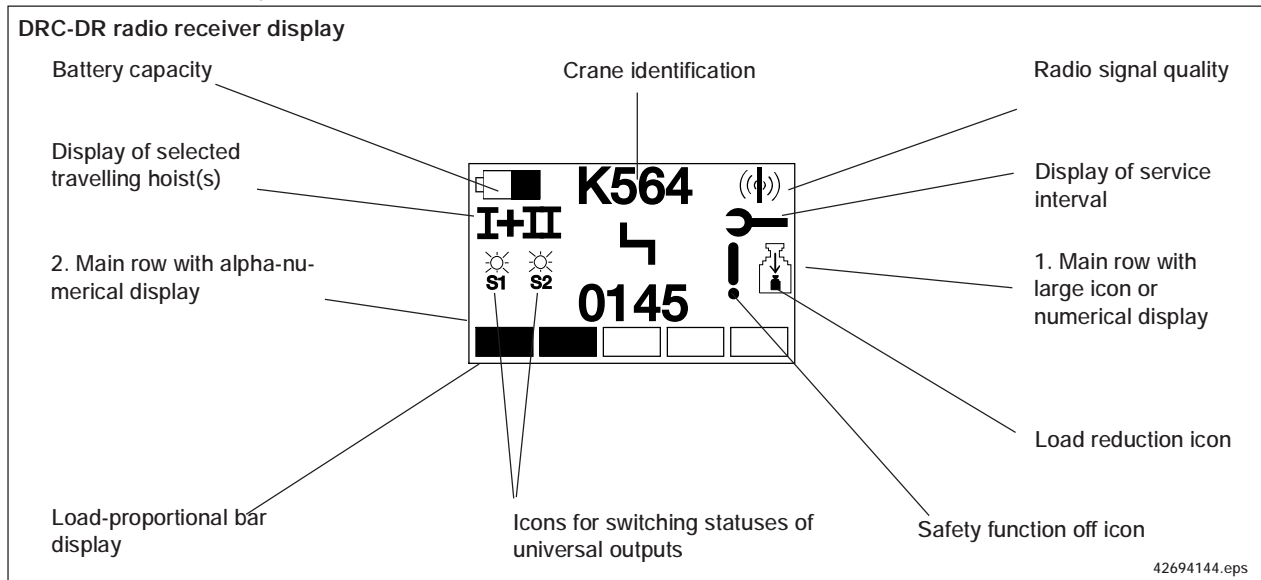

Display of service interval

This icon indicates that the Demag Service or a service company authorized by Demag must be called in for service work.

Icons in the first main row



Fault icon

The fault icon is displayed in the event of a fault.

The code of the fault is displayed in the row below. If there are several faults at the same time, the code displayed changes in cycles.



Overload icon

The overload icon is displayed in the event of an overload. The load of the selected travelling hoist(s) is also displayed in the row below if the hoist is fitted with ZMS.



Brake icon

The brake icon is displayed, if the additional brake has been applied.



“Universal output 1 switching status” icon

This icon is displayed when universal output 1 is active. The function of this output can be programmed.



“Universal output 2 switching status” icon

This icon is displayed when universal output 2 is active. The function of this output can be programmed.



“Attention! Safety function de-activated” icon

This icon indicates that a function relevant for safety such as load reduction or by-pass control has been de-activated by the operator.



“Load reduction active” icon

The icon indicates that load reduction is active. As long as load reduction is active, only the reduced load (specified by a parameter) can be lifted.

Load-proportional bar display

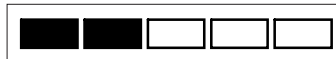

The load-proportional bar display shows the load on the crane in five increments of approx. 20 %. This display is independent of the travelling hoist selection and always refers to the max. possible load.

5.3 Identification labels for the crane installation

Every crane with wireless control must be identified by means of an easily visible crane identification/number. Travel direction symbols on the crane and the travelling hoist must identify the movement directions of the travel motions in line with the identification of the keys on the joysticks of the joystick control unit.

5.3.1 Coding labels

The coding labels are used for illustration of the crane identification on the travelling hoist or on the crane. The crane identification illustrated by means of the coding labels must be identical with the crane identification shown in the display of the DRC-J joystick control system.

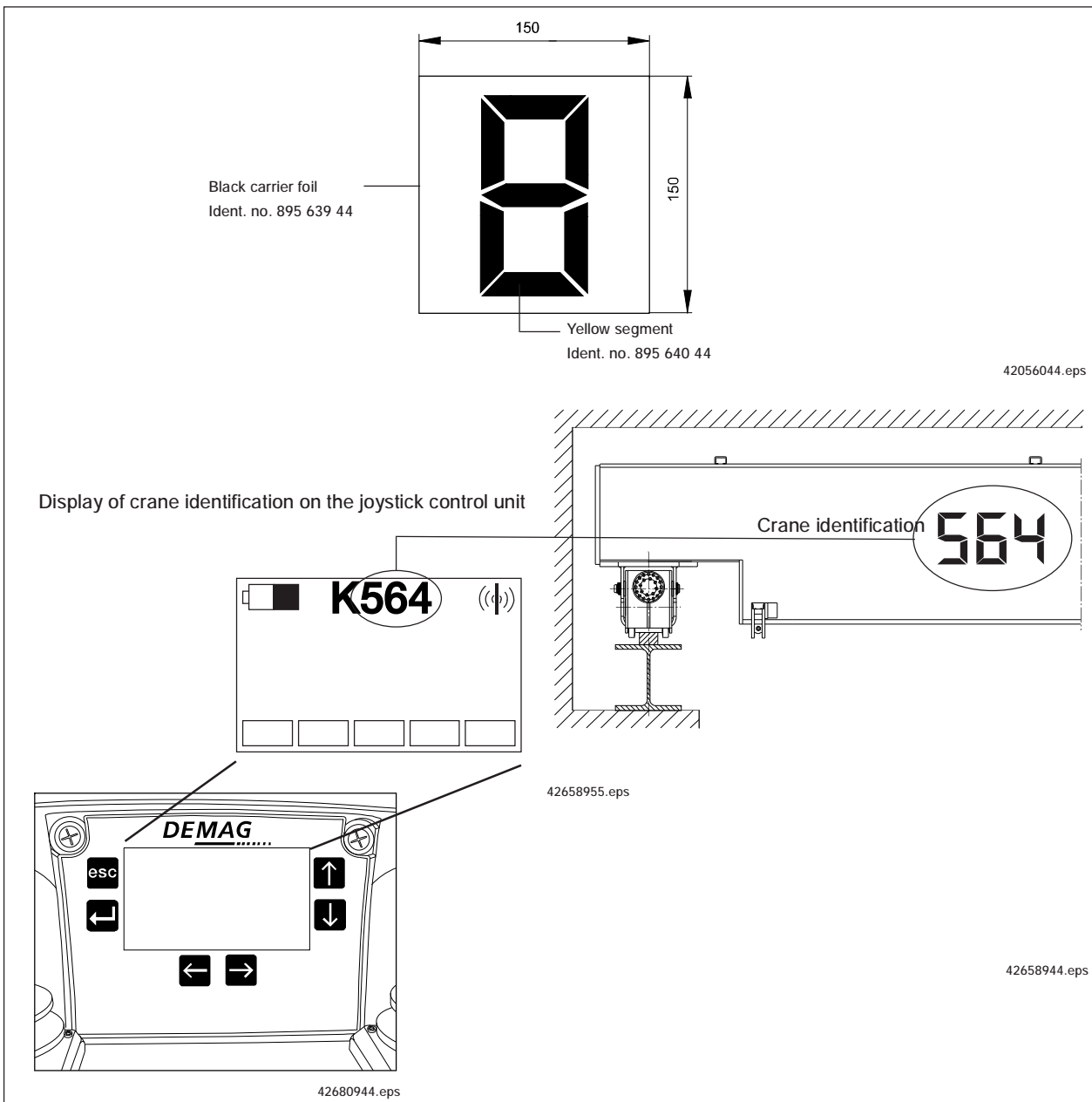

The coding labels (dimensions 150 x 150 mm) (black background foil + foil with number) must be fitted on the hoist unit in such a manner that they are easily visible. Numbers 1 to 9 are produced by removing the yellow segments.

5.3.2 Travel direction symbols

Cross-travel speed
Part no.: 895 635 44

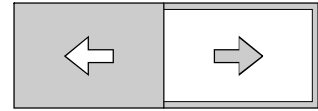

Long-travel speed
Part no.: 895 637 44



The direction labels must be fitted on the hoist unit in an easily visible manner, matching the movement of the drive and in line with the direction symbols on the joystick control unit.

6 Putting the radio control system into operation after installation

- 6.1 Putting into operation** A radio control system has been put into operation when the joystick control unit has been put into operation. The following preparation measures are necessary:
- 6.1.1 Charging the batteries before putting the unit into operation for the first time** The DRC-J joystick control system is already fitted with a rechargeable battery when it is delivered.
Since the new rechargeable battery is only partially charged, it must be charged before the unit is put into operation for the first time by placing it in the charger (see section 8.3).
If no battery icon is displayed when the joystick control unit is activated, the batteries are completely discharged. In this case, the battery must be removed and charged in the external charger (see also chapter 8 „Joystick control unit power supply“).
- 6.1.2 Assembly and connection of the radio receiver** Demag DRC-MP or DRC-DR radio receivers must be fitted in accordance with the relevant operating instructions and connected in accordance with the circuit diagram of the installation. Comply with the instructions and measures described in the operating instructions for putting the radio receiver into operation.
- 6.1.3 Applying the crane identification on the crane** A unique crane identification/number must be selected (recommended: a 3-figure number) and fitted to the crane in accordance with section 5.3 for the crane fitted with the radio control system.

6.2 Putting a radio remote control system with DRC-J into operation

Following these preparation measures, put the joystick control unit into operation by logging it on to the radio receiver of the crane to be controlled. Following this procedure, the radio control system is configured for the specific application.

The Demag DRC-MP or DRC-DR radio receiver on the crane must be supplied with power, be ready for operation and within the range of the joystick control unit.

6.2.1 Switching on the joystick control system

When the unit is switched off, there are no icons in the display, the LED is off. To switch on the joystick control system, first move the key-operated switch to position I and actuate the Start key. Then unlatch the STOP key and press the Start key again.

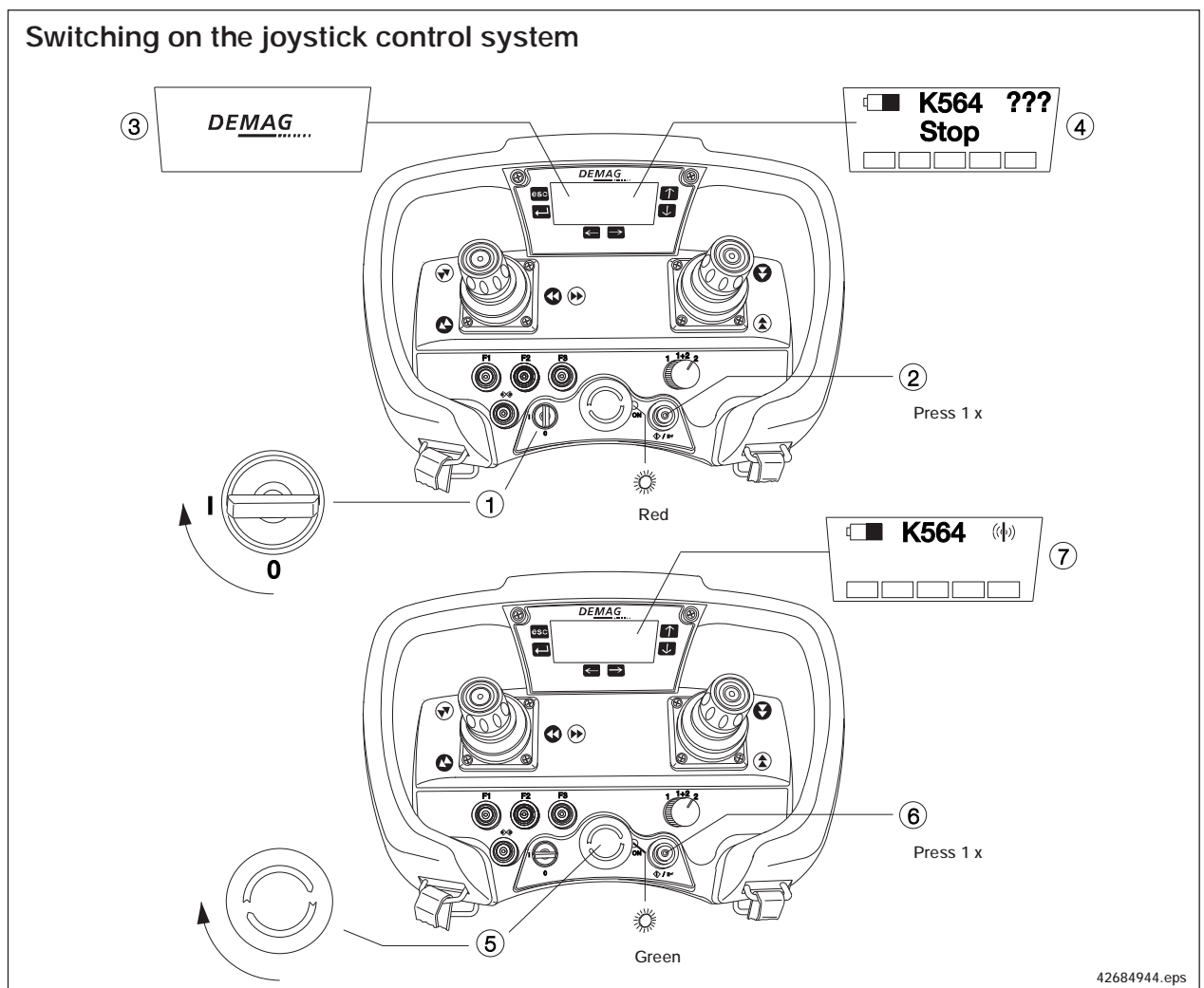

The DEMAG logo is displayed first. The DRC-J joystick control unit scans the radio channels for controllable radio receivers and searches for an assigned radio receiver. Before the joystick control unit has been put into operation for the first time, it has no radio receiver assigned, therefore you can expect the following display:

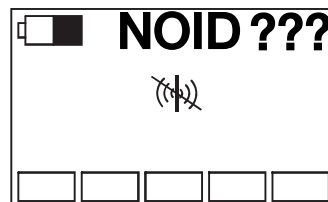

If the transmitter has already been assigned to a receiver in the log-on steps as described in section 6.2.2, you can expect the following display:

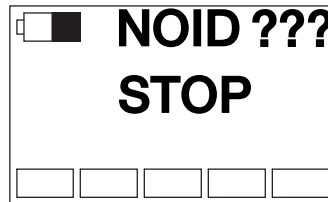

42694344.eps

In this case, continue putting into operation with the assignment of the crane identification, see section 6.2.3.

Note: Additional information may also be shown in the display depending on the type of crane control system.

6.2.2 Logging-on the joystick control system



Logging on a joystick control system as described in the following is a safety-relevant process that may only be carried out by authorized and instructed expert personnel.

Important:

Each receiver is assigned a crane identification when it is put into service (see section 6.2.3).

This crane identification must be shown in a clearly visible manner on the travelling hoist or crane by means of coding labels. When a new joystick control unit is logged on, the crane identification shown on the joystick control unit must match the coding labels on the crane (see section 5.3).

Correct assignment between the transmitter and the crane must be checked by actuating the horn before any crane motion is actuated.



If the correct assignment is not checked, unintended crane movements may cause serious damage and injuries, even resulting in death.

Log-on of a DRC-J joystick control unit to a DRC-MP or DRC-DR radio receiver establishes the assignment between the relevant joystick control unit, the controlled radio receiver and the crane that is unique world-wide. The transmitter and the receiver are provided with unique address features that are exchanged during the log-on process and ensure clear and unique assignment. During the log-on steps, the crane identification (see sections 5.3 and 6.2.2) is also transmitted from the receiver to the joystick control unit and is saved. DRC-J joystick control units show this crane identification/number so that the operating personnel can identify the controlled crane.

Log-on is activated in Run mode or STOP mode.

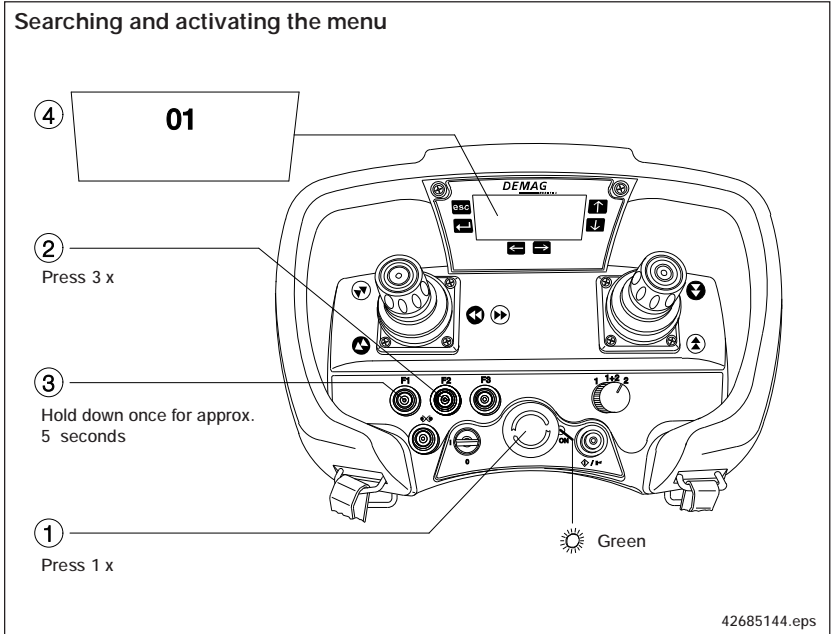

Following activation, a two-digit number is shown in the first main row which indicates the number of controllable radio receivers within the range (the example shows controllable receiver 01).

This process may take several seconds.

Select radio receiver based on crane identification

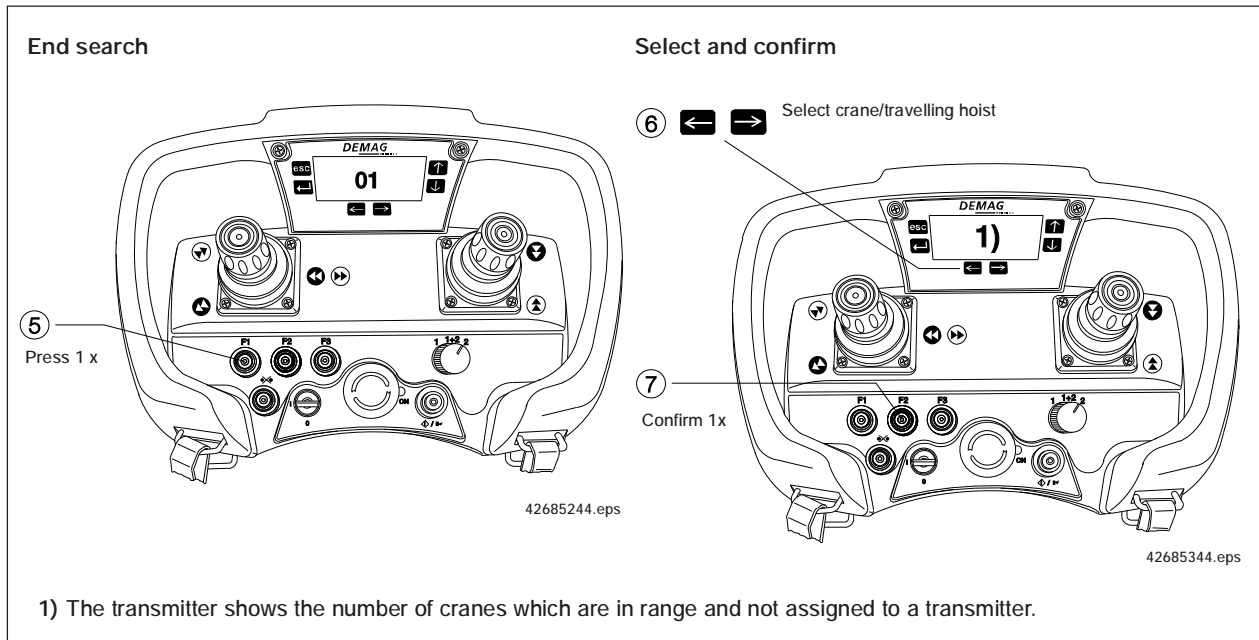

After starting selection with F1, the crane identification of the controllable radio receivers can be displayed one by one by scrolling with the → and ← keys.

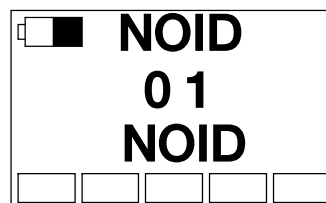

42694444.eps

By pressing the F2 key for confirmation, the joystick control unit is assigned to the DRC-MP or DRC-DR radio receiver whose crane identification is shown in the second main row of the display (NOID in the example). At the same time, the crane identification of the DRC-J joystick control unit is also changed to the new value and displayed next to the battery icon.

Log-on of the joystick control unit is then completed by actuating the ↑ key.

Note: Log-on of the DRC-J joystick control unit to a DRC-MP or DRC-DR radio receiver with code NOID is only necessary when the unit is put into operation for the first time in order to assign the crane identification determined in section 6.2.3 to the receiver.

6.2.3 Assignment of the crane identification/number for the radio receiver

Important! The assignment of the crane identification described in the following for putting the radio receiver into operation is a safety-relevant process that may only be carried out by authorized expert personnel.

After successful establishment of a radio connection between the DRC-J joystick control unit and the DRC-MP or DRC-DR radio receiver, the crane identification determined acc. to section 5.3 must be assigned to the radio receiver. As long as the radio receiver operates with code "NOID", no movement commands are output to the crane control system. (To check radio transmission in this status, use the signal key if Run mode has been activated.)

Activating the assignment

Assignment is activated in STOP mode or Run mode.

- Actuate the STOP key
- Actuate key ↓
- Actuate the → key twice
- Hold down the ↓ key for 5 seconds until the display changes
- Release the ↓ key

The following display appears

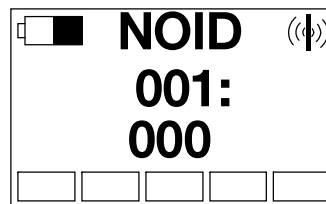

42694544.eps

Note: Additional information may also be shown in the display depending on the type of crane control system.

The code no. of the displayed parameter is shown in the first main row.

The value of the parameter is shown in the second main row.

Selection of parameter 004 for the crane identification/number

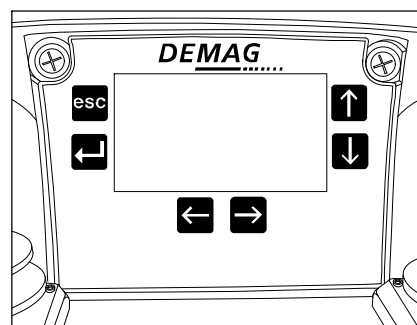

42680944.eps

- Key → increases the displayed parameter code no.
- Key ← decreases the displayed parameter code no.

Entry of the crane identification/number

First select parameter 004, then actuate the F1 key to start entry. The following display appears

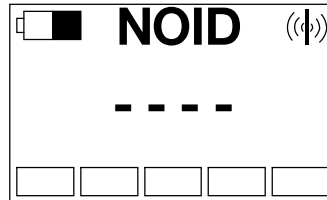

42694644.eps

Four free digits for entry of the crane identification/number are highlighted in the first main row. The first digit is preselected. Use the → and ← keys to select a number/character from the available set of characters. Press the F1 key to accept the selected character and to change to the next position.

Transmitting the assigned crane identification

When the appropriate crane identification has been entered, press the F2 key to confirm and to transmit it to the crane receiver. This crane identification is then saved in the radio receiver. The joystick control unit will keep and display its old crane identification (NOID) until the joystick control unit has been logged on as described in 6.2.2 for the radio receiver with the new crane identification.

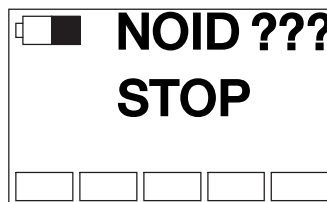

42694344.eps

Cancelling/ending assignment of the crane identification

The entry can be cancelled at any time without changing the crane identification by actuating the ↑ key. Entry is completed by actuating the F2 key. Then use the ↑ key to exit the assignment menu.

Important! After changing the crane identification for the receiver, log-on of the joystick control unit must always be carried out (section 6.2.2) so that the new crane identification is displayed on the joystick control unit.

6.3 Configuration of a radio remote control system for DRC-DR

DR cranes that are provided with the DRC-DR radio receiver use an extended scope of functions of the DRC-J joystick control system for configuration of the crane control system and to display information. Additional instructions and information are described in the operating instructions of the Demag DRC-DR radio receiver (ident. no. 214 953 44) for putting a crane with the DRC-DR radio receiver into operation.

7 Operation of the radio control system

The operator controls the radio-controlled crane by means of the DRC-J joystick control unit.

7.1 Checks before starting work

Before starting work, the operator must carry out the inspections and function checks listed in the crane operating instructions and must be satisfied that the installation is in safe operating condition.

7.1.1 Switching on the joystick control system when starting work

When the unit is switched off, there are no icons in the display, the LED is off. To switch on the joystick control system, first move the key-operated switch to position I and actuate the Start key. Then unlatch the STOP key and press the Start key again.

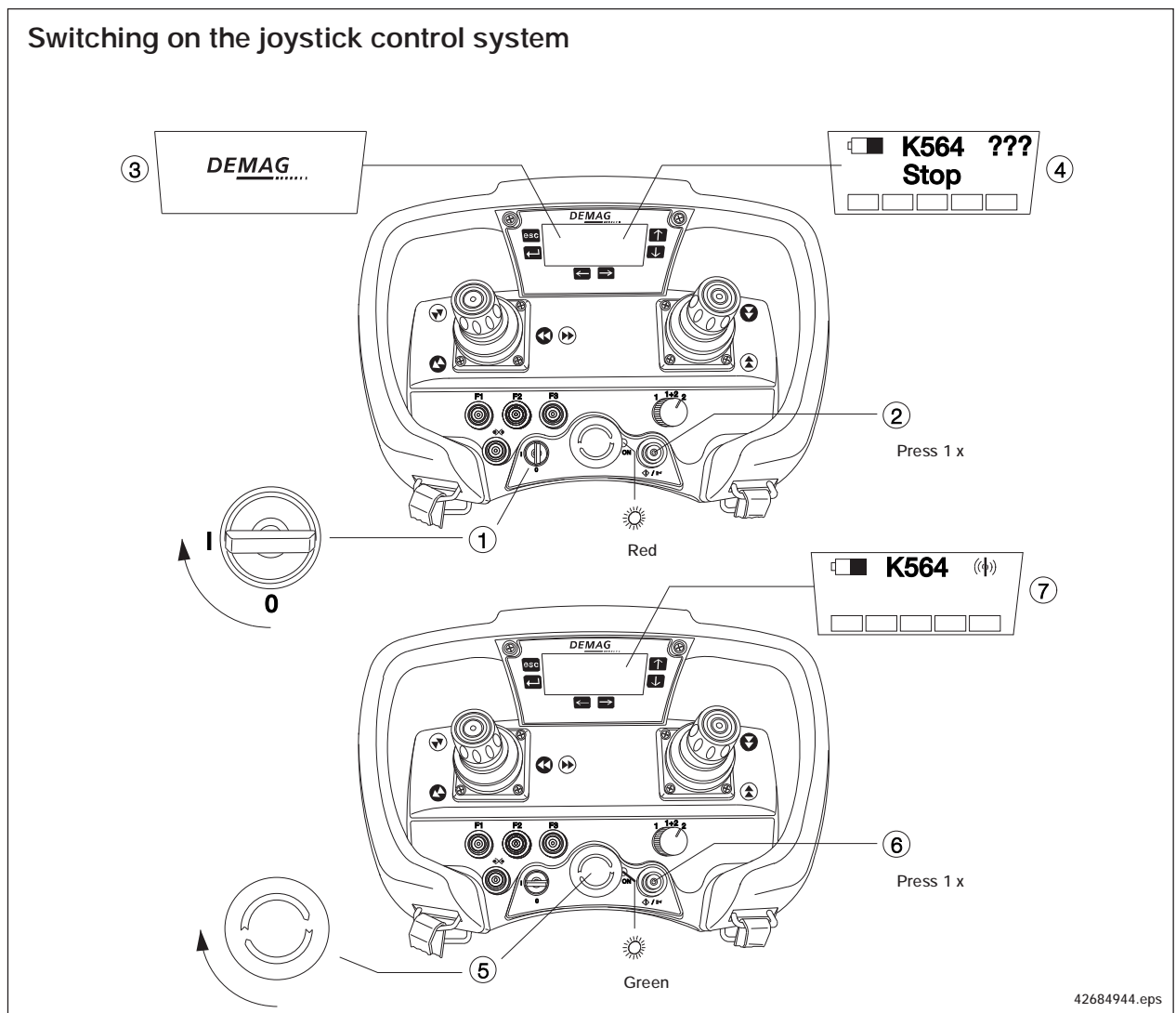

The DEMAG logo is displayed first. When the connection to the radio receiver has been established, the following displays must be shown:

- Crane identification of the assigned radio receiver
- Icon to display the radio signal quality
- Icon to display the battery capacity
- Bar display
- Stop

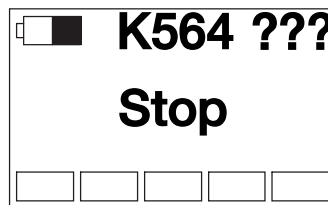

42660044.eps

7.1.2 Checking the radio system

The radio system performs a self-test when it is switched on. The installation is then ready for operation if no error statuses are displayed. Fault elimination is described in chapter 11.

In addition, the crane operator must check the following before starting work:

- Battery capacity 8.2
- Quality of radio connection 5.2.1
- Displayed crane identification and relevant crane 5.2.1
- Function of signal/horn 5.1
- STOP key function 2.7

To check functioning of Signal and STOP, crane operation must be switched on.

7.2 Crane operation/Run

Run mode of the radio system must be started for crane operation. To do this, the On key must be entered. The system switches over to Run/Crane operation mode by means of the On key:

- when the joystick control unit is switched off (steps ① to ⑦)
- from Standby when STOP is actuated (steps ② to ⑦)
- from STOP (steps ⑤ to ⑦)
- from Standby when STOP is not actuated (steps ⑥ to ⑦)

7.2.1 On key

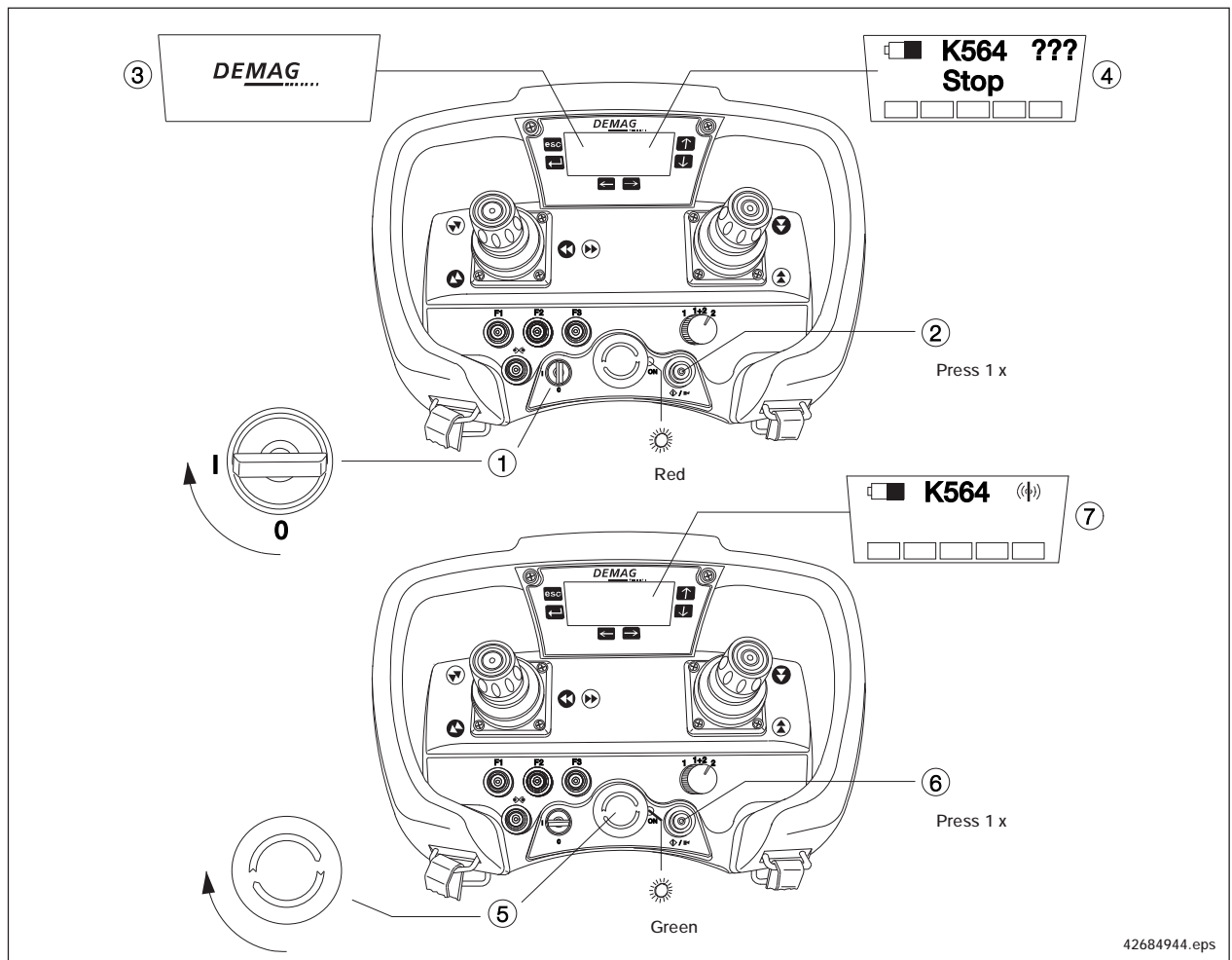

The LED in the display field flashes green if Run mode is switched on after entry.

Sequence ① to ④ causes the control system to be switched on and a radio connection to be established with a receiver in STOP mode.

Sequence ⑤ to ⑦ switches the system to Crane operation/Run mode.

- 7.2.2 Functions in crane operation** In Run mode, the crane (hoist, cross travel, long travel) can be controlled with both self-centering operating levers (see figure in section 5.1).
Lever actuation is stepless after the switch-on threshold to enable control of switched or speed-controlled drives, depending on the design of the crane control system.
- 7.2.3 STOP function** The STOP key identified in red results in a STOP command which stops the movements of hoist, cross travel and long travel at the same time and triggers an emergency-stop in the crane control system.
To avoid danger, the crane operator can immediately stop all movements by means of the STOP key. The braking process caused by an EMERGENCY stop can result in load sway.
The STOP key is also intended to be used for switching the radio-controlled crane into a safe status. This method is to be used when interrupting work for longer periods and for starting additional functions of the joystick control unit for displaying information and servicing purposes.
When STOP has been actuated, crane operation can only be re-activated by unlatching the STOP button and actuating the Start key.
- 7.2.4 Start/Signal key** The Start/Signal key is of single-stage self-resetting design. It simultaneously activates the Start and the Horn signal.
- 7.2.5 F1, F2 and F3 function keys** The function keys are of single-stage self-resetting design. Various additional functions are controlled depending on the design of the radio receiver and the crane control system. These functions are described in the operating instructions of the receiver or the crane installation.
- 7.2.6 Check limit switch key** The check limit switch key is of self-resetting design. It activates an additional signal for the crane control system to test the hoist limit switch function. Refer to relevant guidelines and regulations for radio-controlled cranes for instructions on use.

7.3 Taking out of service at the end of the shift

At the end of the shift or in the event of longer breaks, DRC-J joystick control units must be switched off by means of the key-operated switch to protect the installation against unauthorized use and to reduce power consumption of the DRC-J joystick control unit.

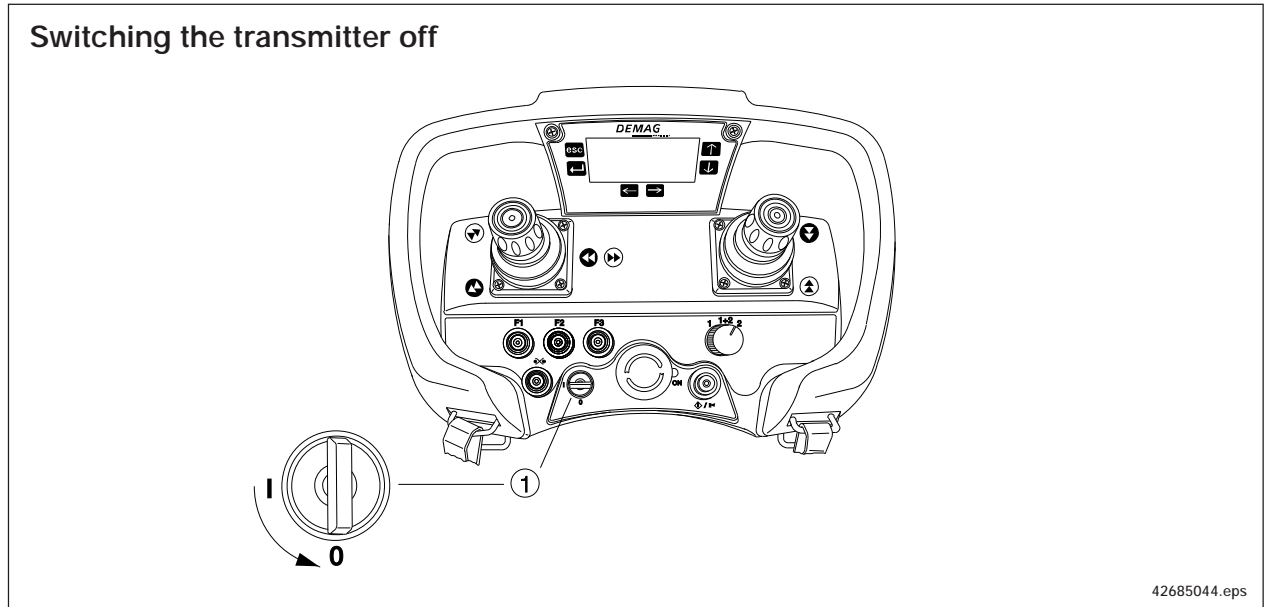

7.4 Operating statuses of the radio control system

The function and display of the radio control system are determined by the operating status of the joystick control unit. The operating status of the joystick control unit is transmitted to the crane control system.

7.4.1 Joystick control system switched off

Display and radio connection are de-activated. Power consumption of the joystick control unit in this status is less than the natural discharge of the battery.

7.4.2 STOP mode

When the STOP button is latched, the joystick control system is in STOP mode, the LED is permanently lit red.

The display shows STOP. No travel commands are transmitted in STOP mode. The EMERGENCY stop contact in the receiver (crane switch for DRC-DR) is open.

The radio connection to the receiver is maintained. Following a timeout period of 5 minutes without any key actuation, the joystick control unit will automatically switch to Standby mode.

7.4.3 Run mode

The LED in the keyboard flashes green. The crane identification of the assigned crane and the icon for the radio connection are shown in the display. In Run mode, the joystick control unit is fully functional for crane operation, see section 7.2.

Crane operation can be started with the On key in "STOP" and "Standby" mode, see section 7.2.1.

Following a timeout period of 30 minutes without any key actuation, the joystick control unit will automatically switch to Standby mode.

7.4.4 Standby mode

The display shows the lock icon. No radio connection is displayed. In standby mode, power consumption of the transmitter is strongly reduced and the radio connection is de-activated.

Standby is automatically switched on by the timeout function as described in sections 7.4.2 and 7.4.3.

The operator can end Standby mode only by actuating the Start key, section 7.2.1, sequence ⑤ to ⑦ and then change to Run mode.

7.4.5 Resetting the joystick control

A reset of the joystick control system may become necessary in the case of error statuses of the software.

The joystick control system can be reset by switching it off by means of the key-operated switch (reset).

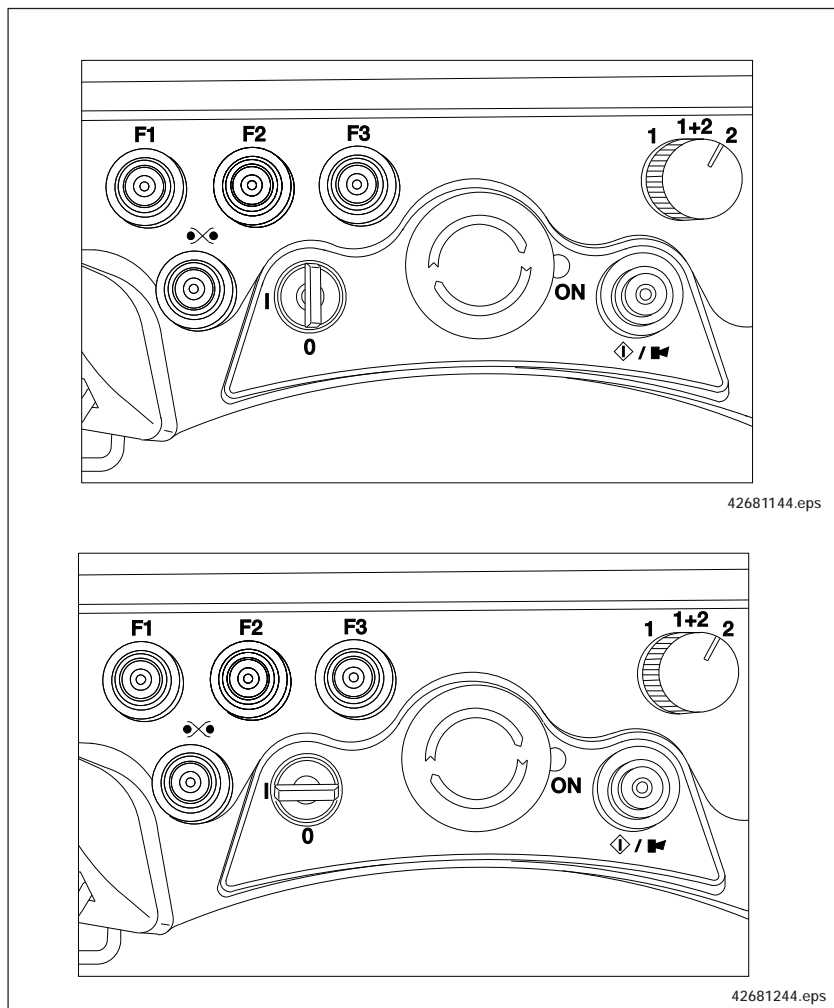

8 Joystick control unit power supply

8.1 General description

The joystick control unit is supplied with power from a rechargeable battery on the underside of the unit (see section 8.4). A discharged rechargeable battery must be removed from the unit and replaced with a charged battery taken from the charger. The charger consists of a charging socket (where the appropriate batteries are inserted) and a pluggable power supply unit.

Connect the pluggable power supply unit to the charging socket as described below.

At the beginning, the charger will charge the battery with a high current, the charging current will then be reduced to trickle charging until the battery is removed.

The normal charging time to charge a completely discharged battery is approx. 3 hours.

The charger has been designed so that the battery will not be damaged even if it remains in the charger for a long time.

Installation:

The charger must be installed at a vibration-free location (inside an enclosed room), it must be protected against humidity, direct radiation from the sun and large changes in temperature.

Permissible temperature range 10 – 45 °C for charging the batteries.

Connect the connector and fix the cable as described (strain relief)

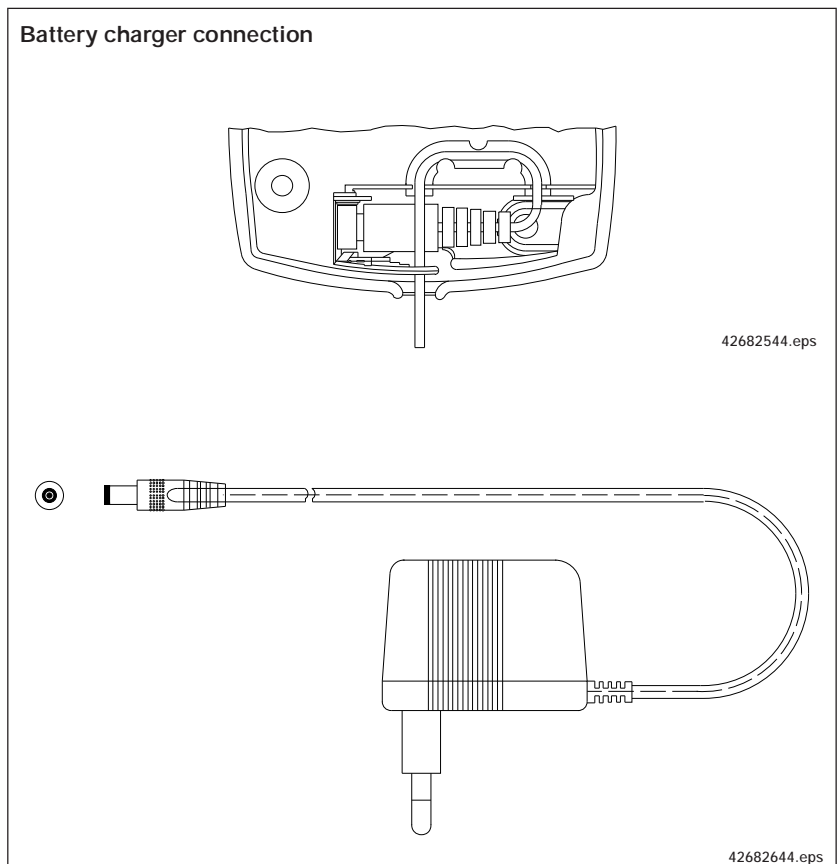

The battery charger starts a charging cycle as soon as a battery is inserted. (Green LED starts flashing) After approx. 3 hours, the battery is completely charged and ready for operation (green LED is now permanently on).

If the power supply to the battery charger is interrupted, the charger remembers the charging status when it is switched on again – accordingly the rapid charging mode or the trickle charging mode is continued when the unit is switched on again.

After 3 hours, rapid charging is stopped as a safety function – regardless of whether the battery is fully charged or not. The green LED is then continuously lit.

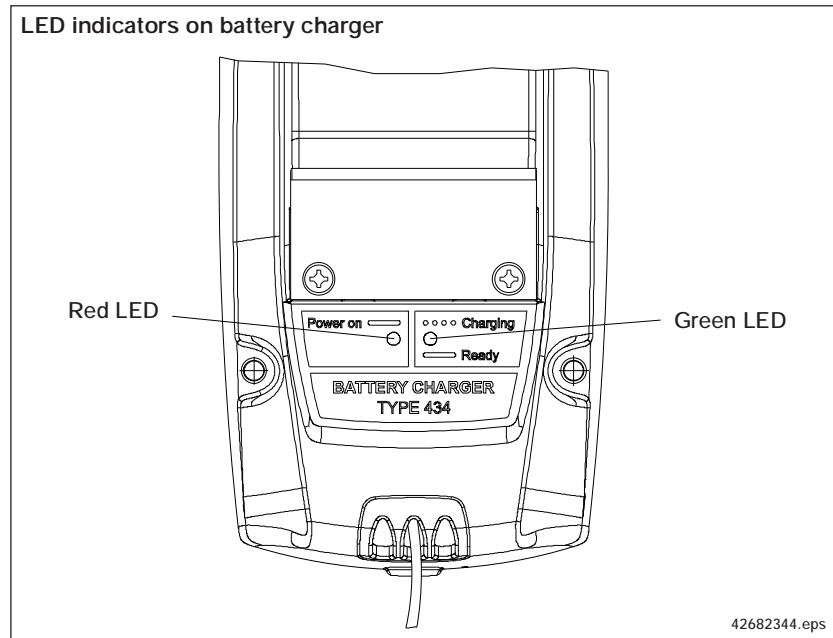

Red LED:	Indicates power supply
Green LED:	Indicates charging status
Green LED flashes:	Battery is being charged (rapid charging)
Green LED permanently on:	Battery charged; charger charges in trickle charging mode

8.2 Display of available battery capacity



The battery capacity is shown in the display of the joystick control unit. The charging status of the battery corresponds to the filled surface in the battery icon. For a new battery, the completely filled battery icon means a useful operating time of the switched-on joystick control unit (Run or STOP) of at least 8 hours.

If only residual charge is displayed, connect the joystick control unit to the charger as soon as possible. If the battery icon is empty, the battery must be charged immediately.

The operating time that can be reached for the joystick control unit with one battery charge depends on the operating mode of the joystick control unit, the ambient temperature and the age of the batteries.

If the joystick control unit is continuously switched on, 12 hours of operation can be achieved with one battery charge.

Power consumption can be reduced by switching the joystick control unit off during longer breaks in operation.

-  Charged battery icon
-  Icon for battery errors.

This icon appears, if a battery problem has occurred, e.g.:

- the battery is defective,
- the battery is too old,

A defective battery must be replaced by a new one (see section 8.4).

8.3 Charging the battery

-  When the battery icon is displayed, immediately charge the removable battery by means of the charger included in the supply.

If the battery is not charged immediately, the battery icon starts to flash and the joystick control unit is switched off after a few seconds.

The charging process is monitored and controlled by the electronics in the joystick control unit. A partly discharged battery can also be charged.

8.4 Replacing the battery

The rechargeable battery in the joystick control unit will age as a consequence of charging/discharging cycles and continuously loses charging capacity. We recommend that the rechargeable battery be replaced after one year, at the latest. A rechargeable battery must immediately be replaced if the relevant icon for a failure in the battery is displayed.

The rechargeable battery supplied with the joystick control unit has been specifically selected for the requirements of this radio control system. The electrical and mechanical features of the joystick control unit and rechargeable battery have been matched to fulfill all requirements of trouble-free and safe operation.

For replacement, use the specified rechargeable battery, part no. 773 462 44. The use of a non-approved rechargeable battery may result in joystick control unit operating malfunctions or lasting damage to the charger and the joystick control unit. Used rechargeable batteries must be disposed of in accordance with environmental protection regulations.

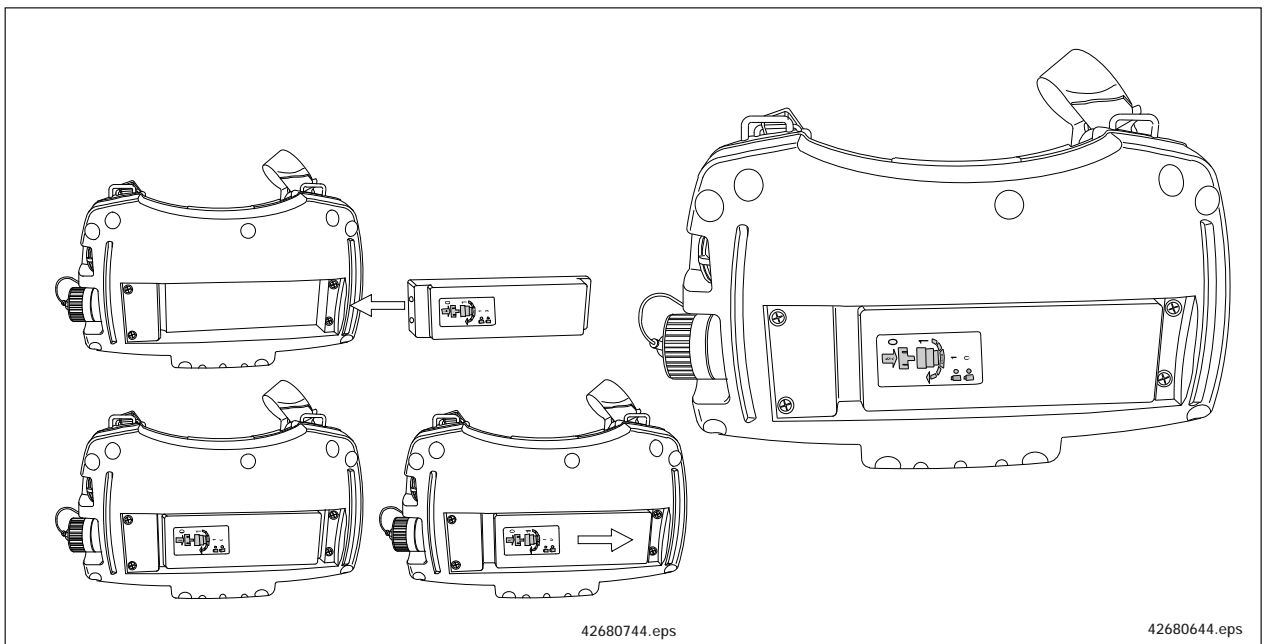

9 Information menu in connection with DRC-DR

This additional function of the joystick control unit can only be used in connection with a DR rope hoist and CAN bus.

The Information menu makes the display of information on the crane or the travelling hoist(s) possible. This information is stored in the form of a list by each DR control system. One element of this list is requested by the joystick control system and made available by the selected control system via the CAN bus.

9.1 Activating the Information menu

- Actuate the STOP key
- Actuate the Return ↵ key three times

The key sequence to activate the Information menu can be cancelled by actuating the Esc key at any time.

9.2 Selecting the information source

Selection of the polled control system is analogue to travelling hoist selection. Since the travelling hoist selection key has no function in the information menu, the travelling hoist must first be selected in the Run operating mode:

Travelling hoist selection Information from

I	Travelling hoist 1 control system
II	Travelling hoist 2 control system
I+II	Crane control system

9.3 Starting screen

After changing to the Information menu, the starting screen of the Information menu is shown in the display of the joystick control unit. This starting screen shows information START II (since travelling hoist 2 has been selected) and code 888:

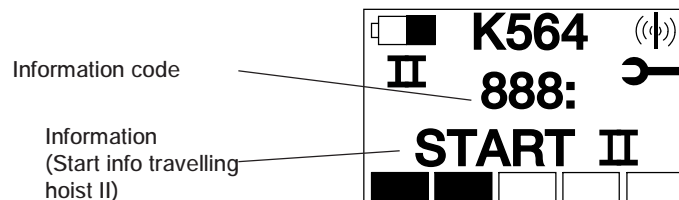

42660744.eps

9.4 Navigating in the information menu

To navigate in the information list, use the following operating elements:

Operating element	Function
Joystick →	to the next value in the list
Joystick ←	back to the previous value in the list
Key↑	exit the Information menu

9.5 Data of the Information menu

The following data can be displayed via the Information menu:

Code	Information
401	Remaining duration of service in % (determined from load spectrum)
400	Operating hours
000	Permissible full load hours acc. to FEM classification
001	Gearbox transmission ratio
002	Drum diameter
003	Reeving factor
004	Control type (travelling hoist or crane control)
005	Solo travelling hoist (with/without crane control)
146	Customer number
147	Order number
148	Serial number
149	Year of manufacture
150	Hoist speed V1
151	Hoist speed V2
152	Lifting height
153	Reeving
155	Rope diameter
171	Country code
216	Serial number of control system
217	Hardware version
520	Software version of main controller
529	Software version of monitoring controller

The following additional information is available with the “board computer” option:

Code	Information
402	K1 switching operations
403	Hoist brake switching operations
404	Travel path in m
405	K2 switching operations
406	K3 switching operations
416	Number of times slip limit is exceeded
417	Number of times the maximum speed is exceeded
418	Number of hoist brake errors
419	Number of times the overspeed brake is triggered
420	Number of overloads
421	Number of emergency stop actuations during motion of min. one axis
448	Last occurring error
449	Last but one occurring error

Sequence and quantity of information depend on the software and may be changed.

The following example shows the remaining duration of service:

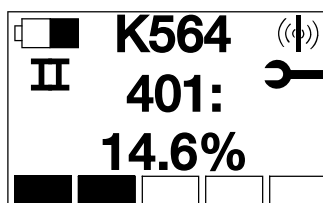

10 Technical data

DRC-J joystick control system

Operating elements

- 1 STOP key
- 1 joystick for the lifting/lowering axis
- 1 joystick for the 2 axes (cross and long-travel)
- 1 mechanical key-operated switch to switch the transmitter on and off
- 1 Horn / start key (to switch the joystick control system on)
- 1 check limit switch key
- 3 special function keys (F1, F2 and F3)
- 1 mechanical 3-stage selector switch (1 or 1+2 or 2)
- Display with keys for menu navigation

- Frequency range: 433.100 to 434.750 MHz
- Transmitter power: max. 10 mW ERP
- Typ. range: approx. 100 m
- Type of enclosure: IP 55
- Temperature range: -20 to +70 °C, at temperatures below 0 °C battery performance decreases. The LCD responds slowly.

Operating time

- with fully charged battery: approx. 8 h

Weight

- incl. re-chargeable battery: 1,8 kg
- without rechargeable battery: 1,6 kg

DRC-J charger

- with suitable pluggable power supply unit: 110 / 230 V AC 50/60 Hz

Rechargeable battery

- Battery type: NiMH, 7,2 V, 1600 mAh

10.1 Dimensions

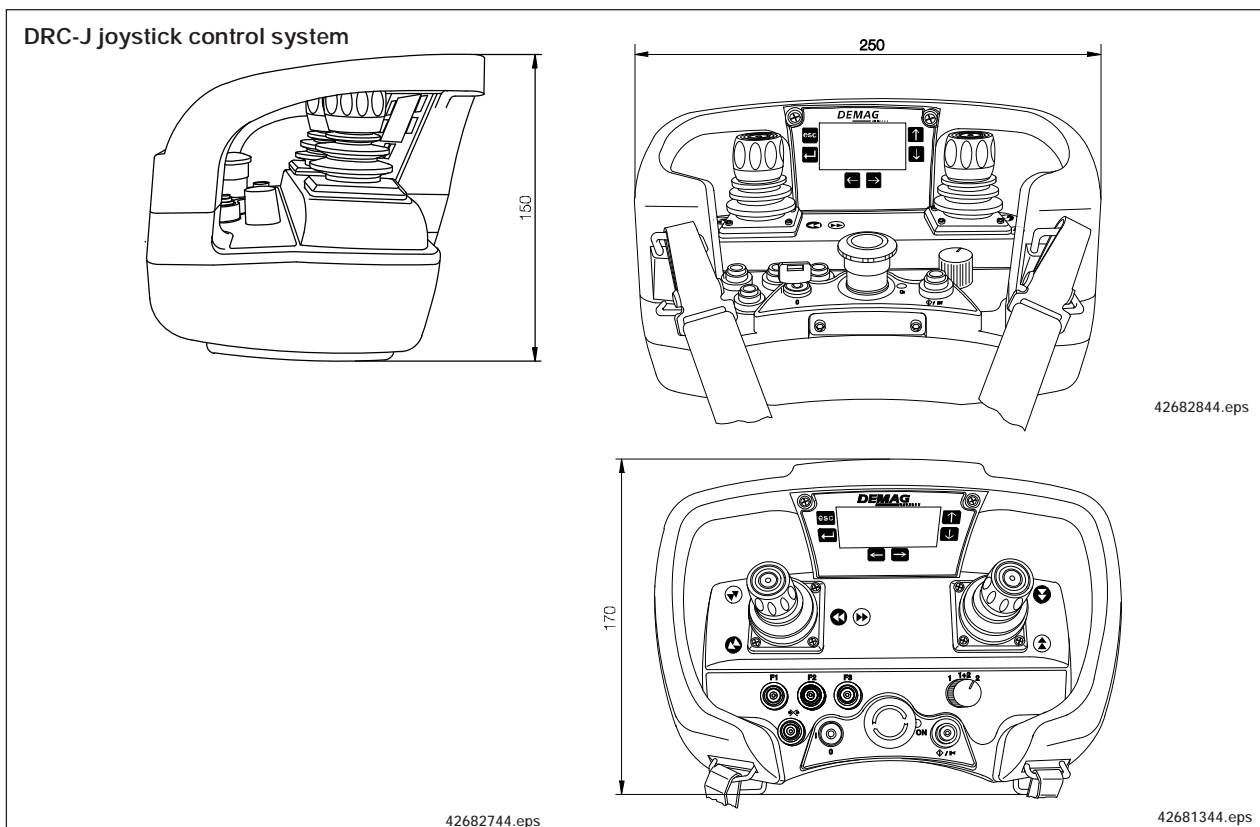

10.2 International postal registration

In the following countries, transmitters and radio receivers of the DRC-J D2 range in the standard delivery form (part no.: 773 591 44) can be operated without any registration or operating fee:

Countries	Frequency range
Australia	433-MHz ISM band
Belgium	433-MHz ISM band
Denmark	433-MHz ISM band
UK	433-MHz ISM band
Estonia	433-MHz ISM band
Finland	433-MHz ISM band
France	433-MHz ISM band
Greece	433-MHz ISM band
Holland	433-MHz ISM band
Ireland	433-MHz ISM band
Iceland	433-MHz ISM band
Italy	433-MHz ISM band
Croatia	433-MHz ISM band
Norway	433-MHz ISM band
New Zealand	433-MHz ISM band
Poland	433-MHz ISM band
Portugal	433-MHz ISM band
Switzerland	433-MHz ISM band
Slovakia	433-MHz ISM band
Slovenia	433-MHz ISM band
Spain	433-MHz ISM band
Sweden	433-MHz ISM band
Czech Republic	433-MHz ISM band
Germany	433-MHz ISM band
Hungary	433-MHz ISM band
Austria	433-MHz ISM band





On request, the relevant approvals and/or certificates are available.







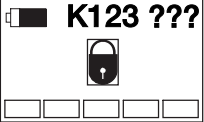
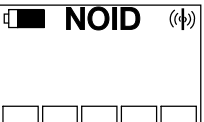

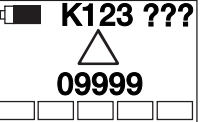

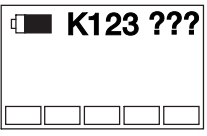

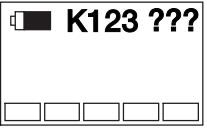
Operation in the following countries requires special approvals (e.g. import license) Russia, Singapore, South Africa, Korea

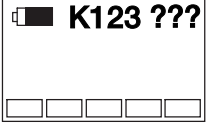
Please contact the manufacturer, if use of the product is planned in the countries mentioned above.

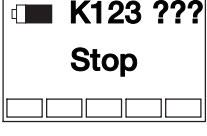
11 Eliminating faults

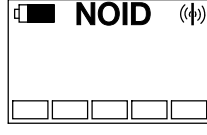
Before eliminating faults by measures on the radio control system, check that the crane installation is supplied with power and is ready for operation and has not been switched off by safety devices. (Mains connection switch, crane isolating switch, STOP switch, travel and lifting path limitation devices, overload protective device, motor protective switch, etc.)

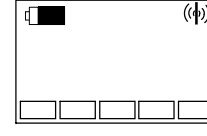
No.	Problem	Indicators	Possible causes	Notes, section in this document
01	Joystick control unit cannot be switched on with key-operated switch	 LED ⚡ Off	Power supply of the joystick control unit has failed	Check rechargeable batteries, see section 8. Replace completely discharged batteries.
02	Joystick control unit cannot be switched on with key-operated switch	 LED ⚡ Off	Joystick control unit has failed	Replace joystick control unit
03	Joystick control unit cannot be switched on with On key	 LED ⚡ Off	Standby mode with latched STOP key	Unlatch STOP key
04	Crane does not respond to key command	 LED ⚡ Green, flashes	Assignment of crane identification is missing	Horn is working; Assign crane identification, 6.2.3
05	Crane does not respond to key command	 LED ⚡ Green, flashes	Assigned crane receiver has no power supply	Switch on crane; check crane receiver acc. to operating instructions
06	Warning during start of crane operation	 LED ⚡ Green, flashes	Re-establishing radio connection after: - Malfunction in DRC-MP receiver - Timeout of joystick control system - Range limits exceeded or Auto-power-off - Power-Down: Short-term undervoltage or voltage failure on the receiver side. - After log-on of a new transmitter	Acknowledge warning with STOP key. Restart with On key 7.2.1

No.	Problem	Indicators	Possible causes	Notes, section in this document
07	The displayed crane does not respond	 <p>LED  Green, flashes</p>	Another joystick control unit has been logged on for the crane	Take the other joystick control unit out of service, 7.3 Log-on joystick control unit again, 6.2.2
08	The displayed crane does not respond	 <p>LED  Red</p>	Power supply of receiver interrupted	Actuate and release the STOP key, then enter the On key, 7.2.1 No. 06 or 10 is then possible
09	The displayed crane does not respond	 <p>LED  Green, flashes</p>	Crane receiver outside range of transmitter	Reduce distance to crane, 2.7 and 5.2.1 Check radio reception by means of log-on procedure 6.2.2. Check aerial connector on receiver.
10	Crane does not respond to key command	 <p>LED  Red</p>	STOP mode	Enter On key, 7.2.1.
11	The crane identification displayed on the joystick control unit is incorrect	 <p>LED  Green, flashes</p>	The crane identification of the receiver was changed with the joystick control unit	Safety problem! A crane that is not displayed is being controlled. Actuate signal to identify the crane. Log-on joystick control unit, 6.2.2
12	The crane identification is missing in the display	 <p>LED  Green, flashes</p>	The crane identification of the receiver was changed with the joystick control unit	Safety problem! A crane that is not displayed is being controlled. Actuate signal to identify the crane. Log-on joystick control unit, 6.2.2
13	Joystick control unit does not respond to key commands	Any malfunctioning display	Software crash	Reset joystick control unit, 7.4.5. Then switch on with key-operated switch.
14	Operating time with fully charged battery too short	Battery display changes to uncharged within a short time.	Charging procedure aborted. The battery is used/too old. Ambient temperature below 10 °C during charging	Repeat charging procedure, 8.1. and 8.4.

1) Additional symbols in the display field are possible

If application of the above instructions does not result in elimination of the fault, please contact Demag customer service.

	EC conformity declaration Demag radio control system in accordance with EC directive 89/336/EEC, Appendix I, 73/23/EEC, Appendix III and 99/5/EC #	1 page(s) Page 1
		Ident. no. 205 331 44
		Issue 0107 EN

Hereby we,



Demag Cranes & Components GmbH

declare that the product

**Demag radio control system RC-10, RC-J,
DRC-10, DRC-J,
DRC-MP, DRC-DR, DRC-DC 1) #**

of serial design is in conformity with the provisions of following relevant regulations:

EC EMC directive	89/336/EEC	
amended by	92/31/EEC and 93/68/EEC	
EC Low voltage Directive	2006/95/EC	
EC radio and TTE directive	99/ 5/EG	#

Applied harmonised standards:

EN 954-1	Safety related parts of control systems
EN 13557	Control elements and control positions
EN 50178	Electronic equipment for use in electrical power installations and their assembly into electrical power installations
EN 60204-32	Electrical equipment, requirements for hoists
EN 60529	Types of enclosure (IP code)
EN 61000-6-2	Electromagnetic compatibility – Immunity for industrial environments
EN 61000-6-4	Electromagnetic compatibility – Emission standard for industrial environments
EN 300220-3	Electromagnetic compatibility and Radio spectrum Matters (ERM); Short Range Devices (SRD)

Wetter, 16 January 2007

Place and date of issue



ppa. Gersemsky
Technik Handling Technology



ppa. Hoffmann
BU Handling Technology

1) Application of CE symbol in accordance with EC Low Voltage Directive 2006/95/EC:
RC-10 1998; RC-J 2000; DRC-10 2004; DRC-J 2004; DRC MP 2005; DRC-DR 2005; DRC-DC 2006.

#

# = Modifications compared to previous issue	Normung DCC	Class. no. 715 IS 975
--	-------------	--------------------------

(For authorized personnel only)



Note:

Parameters 007 and 008 will only be available from the D2 generation of units on (presumably from October 2007 on).

Joystick transmitters with part no. 773 460 44 form part of the D1 generation of units and thus do not fulfil the parameters 007 and 008 described!

Operating instructions

DRC-J joystick control system parameter programming

1 Menu for programming parameters of the joystick control system

The “joystick control system parameter programming” menu can be used by specially trained personnel for displaying and partly changing the following settings of the joystick control unit:

Code	Information
001	Displaying the serial number of the joystick control system
002	Displaying the software version of the joystick control system
003	Displaying the hardware version of the joystick control system
004	Displaying and entering a fixed frequency channel (channel lock)
005	Displaying and entering the cut-out time in STOP mode
006	Displaying and entering the cut-out time in Run mode

Note: Parameters 004 to 008 are set in the factory and must not be changed without prior agreement.

Attention: Changes to the parameters of the joystick control system may impair functioning of the hoist unit.

1.1 Activating the menu

The menu is activated in Run mode or STOP mode.

- Actuate the STOP key
- Actuate the ↑ key
- Actuate the ← key twice
- Actuate the ↑ key again and hold it down for approx. 5 seconds
- Release the ↑ key again

Every change to the “joystick control system parameter programming” menu is signalled to the crane control system.

The key sequence to activate the menu can be cancelled by actuating the Esc key at any time.

1.2 Displaying the current parameters

Only parameters are first displayed after activation of the menu. The display starts with parameter 001, i.e. the serial number of the joystick control system:

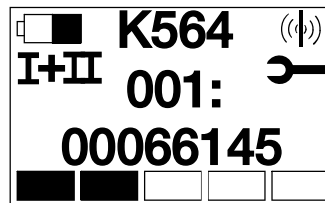

42694744.eps

1.3 Displaying the serial number of the joystick control system, Parameter code 001

Use the → and ← keys to select the parameter to be displayed. The menu can be exited with the ↑ key at any time.

The serial number of the joystick control system is displayed with parameter 001. It is only provided for information and cannot be changed. To navigate, use the following keys:

Key	Function
→	Change to display of parameter 002
←	Change to display of parameter 008
↑	Exit menu

1.4 Displaying the software version of the joystick control system, Parameter code 002

The software version number of the joystick control system is displayed with parameter 002. It is only provided for information and cannot be changed. To navigate, use the following keys:

Key	Function
→	Change to display of parameter 003
←	Change to display of parameter 001
↑	Exit menu

1.5 Displaying the hardware version of the joystick control system, Parameter code 003

The hardware version number of the joystick control system is displayed with parameter 003. It is only provided for information and cannot be changed. To navigate, use the following keys:

Key	Function
→	Change to display of parameter 004
←	Change to display of parameter 002
↑	Exit menu

1.6 Display and entry of a fixed frequency channel, Parameter code 004

This parameter makes it possible to determine the channel used by the radio control system and, therefore, the frequencies used. If a channel is selected, the radio control system uses it instead of searching for a free channel to establish a connection.

The default setting set in the factory is 00, i.e. the radio control system is not locked to a channel. For transmitters with the radio transmission method of frequency hopping, utilization is only with setting 00.

1.6.1 Display mode

The current channel selection is shown in the display. To navigate, use the following keys:

Key	Function
→	Change to display of parameter 005
←	Change to display of parameter 003
↑	Exit parameter programming menu
F1	Change to entry and selection mode

1.6.2 Entry and selection mode

After changing to entry and selection mode, the channel can be selected from possibilities 00 to 11:

Selection	Meaning
00	No lock, search for a free channel to establish a connection. For transmitters with the radio transmission method of frequency hopping, transmission is via all frequencies.
01	Locked to channel 1 (433.300 MHz und 434.300 MHz)
02	Locked to channel 2 (433.325 MHz und 434.325 MHz)
03	Locked to channel 3 (433.350 MHz und 434.350 MHz)
04	Locked to channel 4 (433.375 MHz und 434.375 MHz)
05	Locked to channel 5 (433.400 MHz und 434.400 MHz)
06	Locked to channel 6 (433.425 MHz und 434.425 MHz)
07	Locked to channel 7 (433.450 MHz und 434.450 MHz)
08	Locked to channel 8 (433.475 MHz und 434.475 MHz)
09	Locked to channel 9 (433.500 MHz und 434.500 MHz)
10	Locked to channel 10 (433.525 MHz und 434.525 MHz)
11	Locked to channel 11 (433.550 MHz und 434.550 MHz)

To select and to navigate, use the following keys:

Key	Function
→	Display the next possible value
←	Display the previous possible value
↑	Exit parameter programming menu
F2	Accept the displayed setting

1.7 Displaying and entering the cut-out time in STOP mode, Parameter code 005

1.7.1 Display mode

This parameter defines the time (in seconds) after which the joystick control system switches from STOP mode into power-saving Standby mode (sleep function). The default value set in the factory is a time period of 300 sec.

The current time period is shown in the display. To navigate, use the following keys:

Key	Function
→	Change to display of parameter 006
←	Change to display of parameter 004
↑	Exit parameter programming menu
F1	Change to entry and selection mode

1.7.2 Entry and selection mode

After changing to entry mode, the colon following the parameter code 005 is replaced by an equals symbol. Instead of the current value, the character string "0—" is displayed:

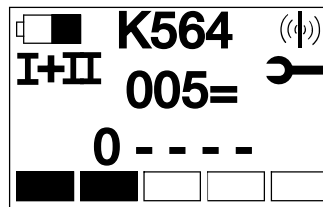

42694844.eps

Entry starts with the first character on the left.

1.7.3 Selection of figures

Use the ← and → keys to select the character for the current position. Only figures 0 – 9 may be used.

1.7.4 Changing to the next position

Change to the next position by actuating the F1 key.

1.7.5 Confirming the new value

Following complete, correct entry, confirm the new value by actuating the F2 key.

1.7.6 Exiting the menu

Entry and the joystick control system parameter programming menu can be exited by actuating the ↑ key at any time. The parameter will remain unchanged, if the ↑ key is actuated before the entered value has been accepted with F2.

1.8 Display and entry of the cut-out time in Run mode, Parameter code 006

This parameter defines the time (in seconds) after which the joystick control system switches from Operating mode into STOP mode (sleep function).

The default value set in the factory is a time period of 1800 sec.

1.8.1 Display mode

The current time period is shown in the display. To navigate, use the following keys:

Key	Function
→	Change to display of parameter 007
←	Change to display of parameter 005
↑	Exit parameter programming menu
F1	Change to entry and selection mode

1.8.2 Entry and selection mode

After changing to entry mode, the colon following the parameter code 006 is replaced by an equals symbol. Instead of the current value, the character string "0—" is displayed. Entry starts with the first character on the left.

1.8.3 Selection of figures

Use the ← and → keys to select the character for the current position. Only figures 0 – 9 may be used.

1.8.4 Changing to the next position

Change to the next position by actuating the F1 key.

1.8.5 Confirming the new value

Following complete, correct entry, confirm the new value by actuating the F2 key.

1.8.6 Exiting the menu

Entry and the joystick control system parameter programming menu can be exited by actuating the ↑ key at any time. The parameter will remain unchanged, if the ↑ key is actuated before the entered value has been accepted with F2.

1.9 Frequency hopping

1.9.1 Downward compatibility with older receivers

DRC-J joystick control systems operated with the frequency hopping method can also be combined with older receivers not featuring the frequency hopping method. In this case, set the DRC-J joystick control system to “Locked frequency operation”, see chapter DRC-J joystick control system parameter programming, section 1.6: Displaying and entering a fixed frequency channel.

The display of the DRC-J joystick control system shows whether it is a frequency hopping transmitter or not, see figure below.

Transmitter without frequency hopping

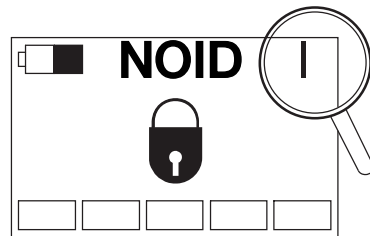

42718344.eps

Transmitter with frequency hopping

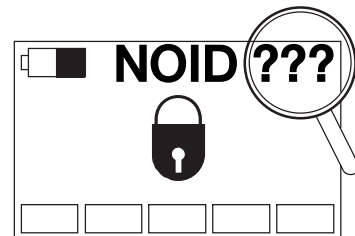

42718244.eps

Notes

Notices and Warnings

This device complies with part 15 of the FCC Rules and RSS-210 of IC Rules. Operation is subject to the following two conditions: (1) This device may not cause harmful interference, and (2) this device must accept any interference received, including interference that may cause undesired operation. Changes or modifications not expressly approved by Scanreco Industrietechnik AB will void the user's authority to operate the equipment.