



# FCC TEST REPORT

**REPORT NO.:** RF120413E03

**MODEL NO.:** IC717w

**FCC ID:** N5C90171701

**RECEIVED:** Apr. 13, 2012

**TESTED:** May 02 to 22, 2012

**ISSUED:** May 28, 2012

**APPLICANT:** StarVedia Technology Inc.

**ADDRESS:** 4F.-1, No.32, Taiyuan St., Jhubei City, Hsinchu County 302, Taiwan

**ISSUED BY:** Bureau Veritas Consumer Products Services (H.K.) Ltd.,  
Taoyuan Branch Hsin Chu Laboratory

**LAB ADDRESS :** No. 81-1, Lu Liao Keng, 9th Ling, Wu Lung Tsuen, Chiung Lin Hsiang, Hsin Chu Hsien 307, Taiwan, R.O.C.

**TEST LOCATION (1):** No. 81-1, Lu Liao Keng, 9th Ling, Wu Lung Tsuen, Chiung Lin Hsiang, Hsin Chu Hsien 307, Taiwan, R.O.C.

**TEST LOCATION (2):** No. 49, Ln. 206, Wende Rd., Shangshan Tsuen, Chiung Lin Hsiang, Hsin Chu Hsien 307, Taiwan, R.O.C.

This report should not be used by the client to claim product certification, approval, or endorsement by TAF or any government agencies.



This report is for your exclusive use. Any copying or replication of this report to or for any other person or entity, or use of our name or trademark, is permitted only with our prior written permission. This report sets forth our findings solely with respect to the test samples identified herein. The results set forth in this report are not indicative or representative of the quality or characteristics of the lot from which a test sample was taken or any similar or identical product unless specifically and expressly noted. Our report includes all of the tests requested by you and the results thereof based upon the information that you provided to us. You have 60 days from date of issuance of this report to notify us of any material error or omission caused by our negligence, provided, however, that such notice shall be in writing and shall specifically address the issue you wish to raise. A failure to raise such issue within the prescribed time shall constitute your unqualified acceptance of the completeness of this report, the tests conducted and the correctness of the report contents. Unless specific mention, the uncertainty of measurement has been explicitly taken into account to declare the compliance or non-compliance to the specification



A D T

## TABLE OF CONTENTS

RELEASE CONTROL RECORD .....	4
1. CERTIFICATION .....	5
2. SUMMARY OF TEST RESULTS .....	6
2.1 MEASUREMENT UNCERTAINTY .....	7
3. GENERAL INFORMATION .....	8
3.1 GENERAL DESCRIPTION OF EUT .....	8
3.2 DESCRIPTION OF TEST MODES .....	10
3.2.1 TEST MODE APPLICABILITY AND TESTED CHANNEL DETAIL .....	11
3.3 GENERAL DESCRIPTION OF APPLIED STANDARDS .....	14
3.4 DESCRIPTION OF SUPPORT UNITS.....	15
3.5 CONFIGURATION OF SYSTEM UNDER TEST .....	15
4. TEST TYPES AND RESULTS .....	16
4.1 CONDUCTED EMISSION MEASUREMENT .....	16
4.1.1 LIMITS OF CONDUCTED EMISSION MEASUREMENT .....	16
4.1.2 TEST INSTRUMENTS.....	16
4.1.3 TEST PROCEDURES .....	17
4.1.4 DEVIATION FROM TEST STANDARD .....	17
4.1.5 TEST SETUP .....	18
4.1.6 EUT OPERATING CONDITIONS .....	18
4.1.7 TEST RESULTS .....	19
4.2 RADIATED EMISSION AND BANDEDGE MEASUREMENT .....	23
4.2.1 LIMITS OF RADIATED EMISSION AND BANDEDGE MEASUREMENT .....	23
4.2.2 TEST INSTRUMENTS.....	24
4.2.3 TEST PROCEDURES .....	25
4.2.4 DEVIATION FROM TEST STANDARD .....	25
4.2.5 TEST SETUP .....	26
4.2.6 EUT OPERATING CONDITIONS .....	26
4.2.7 TEST RESULTS .....	27
4.3 6dB BANDWIDTH MEASUREMENT .....	40
4.3.1 LIMITS OF 6dB BANDWIDTH MEASUREMENT .....	40
4.3.2 TEST INSTRUMENTS.....	40
4.3.3 TEST PROCEDURE.....	40
4.3.4 DEVIATION FROM TEST STANDARD .....	40
4.3.5 TEST SETUP .....	40
4.3.6 EUT OPERATING CONDITIONS .....	40
4.3.7 TEST RESULTS .....	41
4.4 CONDUCTED OUTPUT POWER MEASUREMENT .....	42
4.4.1 LIMITS OF MAXIMUM PEAK OUTPUT POWER MEASUREMENT .....	42
4.4.2 INSTRUMENTS.....	42
4.4.3 TEST PROCEDURES .....	42



A D T

4.4.4	DEVIATION FROM TEST STANDARD .....	42
4.4.5	TEST SETUP .....	42
4.4.6	EUT OPERATING CONDITIONS .....	42
4.4.7	TEST RESULTS .....	43
4.5	POWER SPECTRAL DENSITY MEASUREMENT .....	44
4.5.1	LIMITS OF POWER SPECTRAL DENSITY MEASUREMENT .....	44
4.5.2	TEST INSTRUMENTS.....	44
4.5.3	TEST PROCEDURE.....	44
4.5.4	DEVIATION FROM TEST STANDARD .....	44
4.5.5	TEST SETUP .....	44
4.5.6	EUT OPERATING CONDITION.....	44
4.5.7	TEST RESULTS .....	45
4.6	CONDUCTED OUT-BAND EMISSION MEASUREMENT .....	46
4.6.1	LIMITS OF CONDUCTED OUT-BAND EMISSION MEASUREMENT.....	46
4.6.2	TEST INSTRUMENTS.....	46
4.6.3	TEST PROCEDURE.....	46
4.6.4	DEVIATION FROM TEST STANDARD .....	47
4.6.5	TEST SETUP .....	47
4.6.6	EUT OPERATING CONDITION.....	47
4.6.7	TEST RESULTS .....	47
5.	PHOTOGRAPHS OF THE TEST CONFIGURATION.....	52
6.	INFORMATION ON THE TESTING LABORATORIES .....	53
7.	APPENDIX A - MODIFICATIONS RECORDERS FOR ENGINEERING CHANGES TO THE EUT BY THE LAB.....	54



A D T

## RELEASE CONTROL RECORD

ISSUE NO.	REASON FOR CHANGE	DATE ISSUED
RF120413E03	Original release	May 28, 2012



A D T

## 1. CERTIFICATION

**PRODUCT:** Wireless Cam  
**BRAND NAME:** StarVedia  
**MODEL NO.:** IC717w  
**TEST SAMPLE:** R&D SAMPLE  
**APPLICANT:** StarVedia Technology Inc.  
**TESTED:** May 02 to 22, 2012  
**STANDARDS:** **FCC Part 15, Subpart C (Section 15.247)**  
ANSI C63.10-2009

The above equipment (Model: IC717w) has been tested by **Bureau Veritas Consumer Products Services (H.K.) Ltd., Taoyuan Branch**, and found compliance with the requirement of the above standards. The test record, data evaluation & Equipment Under Test (EUT) configurations represented herein are true and accurate accounts of the measurements of the sample's EMC characteristics under the conditions specified in this report.

**PREPARED BY :** Phoenix Huang , **DATE:** May 28, 2012  
( Phoenix Huang, Specialist )

**APPROVED BY :** May Chen , **DATE:** May 28, 2012  
( May Chen, Deputy Manager )

## 2. SUMMARY OF TEST RESULTS

The EUT has been tested according to the following specifications:

APPLIED STANDARD: FCC PART 15, SUBPART C (SECTION 15.247)			
STANDARD SECTION	TEST TYPE	RESULT	REMARK
15.207	AC Power Conducted Emission	PASS	Meet the requirement of limit. Minimum passing margin is -0.84dB at 0.34531MHz
15.247(d) 15.209	Radiated Emissions	PASS	Meet the requirement of limit. Minimum passing margin is -0.5dB at 2483.50MHz & 4874.00MHz
15.247(d)	Band Edge Measurement	PASS	Meet the requirement of limit.
15.247(a)(2)	6dB bandwidth	PASS	Meet the requirement of limit.
15.247(b)	Conducted power	PASS	Meet the requirement of limit.
15.247(e)	Power Spectral Density	PASS	Meet the requirement of limit.
15.203	Antenna Requirement	PASS	No antenna connector is used.



A D T

## 2.1 MEASUREMENT UNCERTAINTY

Where relevant, the following measurement uncertainty levels have been estimated for tests performed on the EUT as specified in CISPR 16-4-2:

This uncertainty represents an expanded uncertainty expressed at approximately the 95% confidence level using a coverage factor of  $k=2$ .

Measurement	Value
Conducted emissions	2.98 dB
Radiated emissions (30MHz-1GHz)	5.69 dB
Radiated emissions (1GHz -6GHz)	5.12 dB
Radiated emissions (6GHz -18GHz)	5.32 dB
Radiated emissions (18GHz -40GHz)	5.37 dB



A D T

### 3. GENERAL INFORMATION

#### 3.1 GENERAL DESCRIPTION OF EUT

<b>PRODUCT</b>	Wireless Cam
<b>MODEL NO.</b>	IC717w
<b>POWER SUPPLY</b>	DC 12V or DC 5V from power adapter
<b>MODULATION TYPE</b>	CCK, DQPSK, DBPSK for DSSS 64QAM, 16QAM, QPSK, BPSK for OFDM
<b>MODULATION TECHNOLOGY</b>	DSSS, OFDM
<b>TRANSFER RATE</b>	802.11b: Up to 11Mbps 802.11g: Up to 54Mbps HT20 (800ns GI): Up to 65Mbps HT40 (800ns GI): Up to 135Mbps. HT20 (400ns GI): Up to 72.2Mbps. HT40 (400ns GI): Up to 150.0Mbps.
<b>OPERATING FREQUENCY</b>	2.412 ~ 2.462GHz
<b>NUMBER OF CHANNEL</b>	11 for 802.11b, 802.11g, 802.11n (20MHz) 7 for 802.11n (40MHz)
<b>MAXIMUM OUTPUT POWER</b>	802.11b: 42.658mW 802.11g: 301.995mW 802.11n (20MHz): 309.030mW 802.11n (40MHz): 281.838mW
<b>ANTENNA TYPE</b>	Please see NOTE
<b>DATA CABLE</b>	NA
<b>I/O PORTS</b>	Refer to user's manual
<b>ASSOCIATED DEVICES</b>	Adapter × 1





A D T

**NOTE:**

1. The antennas provided to the EUT, please refer to the following table:

Transmitter Circuit	Gain (dBi) (Include cable loss)	Antenna Type	Freq. range (MHz to MHz)	Connecter Type
Chain (0)	0.01	Printed Antenna	2400 ~ 2500	NA
Chain (1)	0.01			

2. The EUT must be supplied with a power adapter and following two different model names could be chosen:

ADAPTER 1	
<b>BRAND:</b>	DVE
<b>MODEL NO.:</b>	DSA-12CA-12 120100
<b>INPUT POWER:</b>	AC 100-240V, 50/60Hz, 0.3A
<b>OUTPUT POWER:</b>	DC 12V, 1A DC output cable: Unshielded, 1.5m
ADAPTER 2	
<b>BRAND:</b>	L.T.E.
<b>MODEL NO.:</b>	LTE05W-S1
<b>INPUT POWER:</b>	AC 100-240V, 50/60Hz, 1A
<b>OUTPUT POWER:</b>	DC 5V, 1A DC output cable: Unshielded, 1.9m

3. The EUT incorporates a SIMO function.

MODULATION MODE	TX/Rx FUNCTION
802.11b	1Tx/1Rx
802.11g	1Tx/1Rx
802.11n (20MHz)	1Tx/2Rx
802.11n (40MHz)	1Tx/2Rx

4. The EUT is 1 \* 1 spatial SIMO (1Tx & 2Rx) without beam forming function.
5. When the EUT operating in 802.11n, the software operation, which is defined by manufacturer, MCS (Modulation and Coding Schemes) from 0 to 7.
6. The above EUT information was declared by the manufacturer and for more detailed features description, please refer to the manufacturer's specifications or User's Manual.

### 3.2 DESCRIPTION OF TEST MODES

Eleven channels are provided for 802.11b, 802.11g, 802.11n (20MHz):

CHANNEL	FREQUENCY	CHANNEL	FREQUENCY
1	2412MHz	7	2442MHz
2	2417MHz	8	2447MHz
3	2422MHz	9	2452MHz
4	2427MHz	10	2457MHz
5	2432MHz	11	2462MHz
6	2437MHz		

Seven channels are provided for 802.11n (40MHz):

CHANNEL	FREQUENCY	CHANNEL	FREQUENCY
3	2422MHz	7	2442MHz
4	2427MHz	8	2447MHz
5	2432MHz	9	2452MHz
6	2437MHz		



### 3.2.1 TEST MODE APPLICABILITY AND TESTED CHANNEL DETAIL

EUT CONFIGURE MODE	APPLICABLE TO					DESCRIPTION
	PLC	RE < 1G	RE ≥ 1G	APCM	OB	
1	√	-	-	-	-	Adapter 1
2	√	√	√	√	√	Adapter 2

Where **PLC**: Power Line Conducted Emission                      **RE < 1G**: Radiated Emission below 1GHz  
**RE ≥ 1G**: Radiated Emission above 1GHz                      **APCM**: Antenna Port Conducted Measurement  
**OB**: Conducted Out-Band Emission Measurement

**NOTE:** The EUT had been pre-tested on the positioned of each 3 axis. The worst case was found when positioned on **Z-plane** (below 1GHz) and **X-plane** (above 1GHz).

#### **POWER LINE CONDUCTED EMISSION TEST:**

- Pre-Scan has been conducted to determine the worst-case mode from all possible combinations between available modulations, data rates and antenna ports (if EUT with antenna diversity architecture).
- Following channel(s) was (were) selected for the final test as listed below.

MODE	AVAILABLE CHANNEL	TESTED CHANNEL	MODULATION TECHNOLOGY	MODULATION TYPE	DATA RATE (Mbps)
802.11n (20MHz)	1 to 11	1	OFDM	BPSK	6.5

#### **RADIATED EMISSION TEST (BELOW 1 GHz):**

- Pre-Scan has been conducted to determine the worst-case mode from all possible combinations between available modulations, data rates and antenna ports (if EUT with antenna diversity architecture).
- Following channel(s) was (were) selected for the final test as listed below.

MODE	AVAILABLE CHANNEL	TESTED CHANNEL	MODULATION TECHNOLOGY	MODULATION TYPE	DATA RATE (Mbps)
802.11n (20MHz)	1 to 11	1	OFDM	BPSK	6.5

**RADIATED EMISSION TEST (ABOVE 1 GHz):**

- Pre-Scan has been conducted to determine the worst-case mode from all possible combinations between available modulations, data rates and antenna ports (if EUT with antenna diversity architecture).
- Following channel(s) was (were) selected for the final test as listed below.

MODE	AVAILABLE CHANNEL	TESTED CHANNEL	MODULATION TECHNOLOGY	MODULATION TYPE	DATA RATE (Mbps)
802.11b	1 to 11	1, 6, 11	DSSS	DBPSK	1
802.11g	1 to 11	1, 6, 11	OFDM	BPSK	6
802.11n (20MHz)	1 to 11	1, 6, 11	OFDM	BPSK	6.5
802.11n (40MHz)	3 to 9	3, 6, 9	OFDM	BPSK	13.5

**ANTENNA PORT CONDUCTED MEASUREMENT:**

- Pre-Scan has been conducted to determine the worst-case mode from all possible combinations between available modulations, data rates and antenna ports (if EUT with antenna diversity architecture).
- Following channel(s) was (were) selected for the final test as listed below.

MODE	AVAILABLE CHANNEL	TESTED CHANNEL	MODULATION TECHNOLOGY	MODULATION TYPE	DATA RATE (Mbps)
802.11b	1 to 11	1, 6, 11	DSSS	DBPSK	1
802.11g	1 to 11	1, 6, 11	OFDM	BPSK	6
802.11n (20MHz)	1 to 11	1, 6, 11	OFDM	BPSK	6.5
802.11n (40MHz)	3 to 9	3, 6, 9	OFDM	BPSK	13.5

**CONDUCTED OUT-BAND EMISSION MEASUREMENT:**

- Pre-Scan has been conducted to determine the worst-case mode from all possible combinations between available modulations, data rates and antenna ports (if EUT with antenna diversity architecture).
- Following channel(s) was (were) selected for the final test as listed below.

MODE	AVAILABLE CHANNEL	TESTED CHANNEL	MODULATION TECHNOLOGY	MODULATION TYPE	DATA RATE (Mbps)
802.11b	1 to 11	1, 6, 11	DSSS	DBPSK	1
802.11g	1 to 11	1, 6, 11	OFDM	BPSK	6
802.11n (20MHz)	1 to 11	1, 6, 11	OFDM	BPSK	6.5
802.11n (40MHz)	3 to 9	3, 6, 9	OFDM	BPSK	13.5



A D T

**TEST CONDITION:**

APPLICABLE TO	ENVIRONMENTAL CONDITIONS	INPUT POWER	TESTED BY
PLC	26deg. C, 65%RH	120Vac, 60Hz	Bear Lee
	26deg. C, 61%RH	120Vac, 60Hz	Kyle Huang
RE<1G	27deg. C, 64%RH	120Vac, 60Hz	Kent Liu
RE <sup>3</sup> 1G	24deg. C, 70%RH	120Vac, 60Hz	Kent Liu
	26deg. C, 68%RH	120Vac, 60Hz	Kent Liu
APCM	25deg. C, 60%RH	120Vac, 60Hz	Rex Huang
OB	25deg. C, 60%RH	120Vac, 60Hz	Rex Huang

### 3.3 GENERAL DESCRIPTION OF APPLIED STANDARDS

The EUT is a RF product. According to the specifications of the manufacturer, it must comply with the requirements of the following standards:

#### **FCC Part 15, Subpart C (15.247)**

ANSI C63.10-2009

All test items have been performed and recorded as per the above standards.

**NOTE:** The EUT has been verified to comply with the requirements of FCC Part 15, Subpart B, Class B (DoC). The test report has been issued separately.

### 3.4 DESCRIPTION OF SUPPORT UNITS

The EUT has been tested as an independent unit together with other necessary accessories or support units. The following support units or accessories were used to form a representative test configuration during the tests.

No.	Product	Brand	Model No.	Serial No.	FCC ID
1	SPEAKERS	J-S	JY2003	090404619	FCC DoC
2	microSD CARD	PNY	1G	BA6P000844	NA

No.	Signal cable description
1	Audio cable (1m)
2	NA

Note: The power cords of the above support units were unshielded (1.8m).

### 3.5 CONFIGURATION OF SYSTEM UNDER TEST

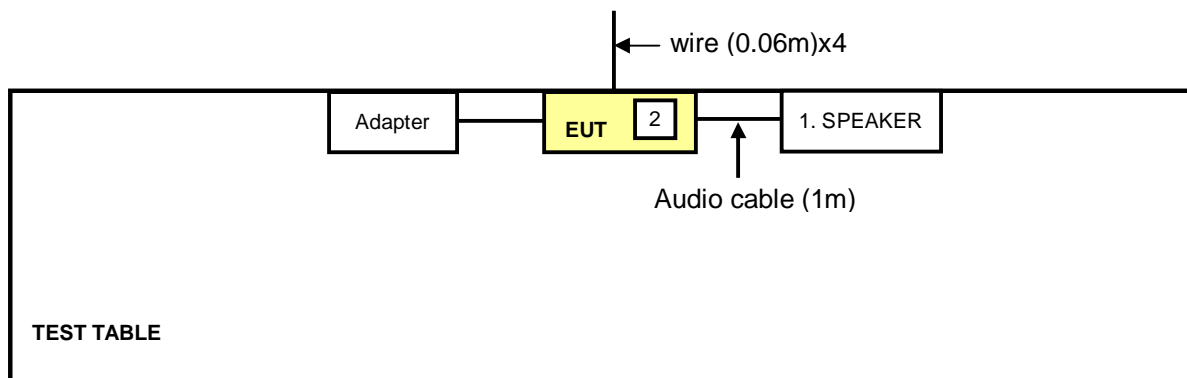

**Note:** The item 2 is microSD CARD.

## 4. TEST TYPES AND RESULTS

### 4.1 CONDUCTED EMISSION MEASUREMENT

#### 4.1.1 LIMITS OF CONDUCTED EMISSION MEASUREMENT

FREQUENCY OF EMISSION (MHz)	CONDUCTED LIMIT (dB $\mu$ V)	
	Quasi-peak	Average
0.15-0.5	66 to 56	56 to 46
0.5-5	56	46
5-30	60	50

- NOTE:**
1. The lower limit shall apply at the transition frequencies.
  2. The limit decreases in line with the logarithm of the frequency in the range of 0.15 to 0.50 MHz.

#### 4.1.2 TEST INSTRUMENTS

DESCRIPTION & MANUFACTURER	MODEL NO.	SERIAL NO.	CALIBRATED DATE	CALIBRATED UNTIL
Test Receiver	ESCS 30	100375	Mar. 08, 2012	Mar. 07, 2013
Line-Impedance Stabilization Network (for EUT) SCHWARZBECK	NSLK8127	8127-522	Sep. 07, 2011	Sep. 06, 2012
Line-Impedance Stabilization Network (for Peripheral)	ESH3-Z5	848773/004	Nov. 02, 2011	Nov. 01, 2012
RF Cable (JYEBAO)	5DFB	COCCAB-001	Aug. 29, 2011	Aug. 28, 2012
50 ohms Terminator	50	3	Nov. 02, 2011	Nov. 01, 2012
Software ADT	BV ADT_Cond_V7.3.7	NA	NA	NA

**Note:**

1. The calibration interval of the above test instruments is 12 months and the calibrations are traceable to NML/ROC and NIST/USA.
2. The test was performed in Shielded Room No. C.
- 3 The VCCI Con C Registration No. is C-3611.
- 4 Tested Date: May 02 to 22, 2012



#### 4.1.3 TEST PROCEDURES

- a. The EUT/HOST was placed 0.4 meters from the conducting wall of the shielded room with EUT/HOST being connected to the power mains through a line impedance stabilization network (LISN). Other support units were connected to the power mains through another LISN. The two LISNs provide 50 ohm/ 50uH of coupling impedance for the measuring instrument.
- b. Both lines of the power mains connected to the EUT were checked for maximum conducted interference.
- c. The frequency range from 150kHz to 30MHz was searched. Emission levels under (Limit - 20dB) were not recorded.

#### 4.1.4 DEVIATION FROM TEST STANDARD

No deviation

#### 4.1.5 TEST SETUP

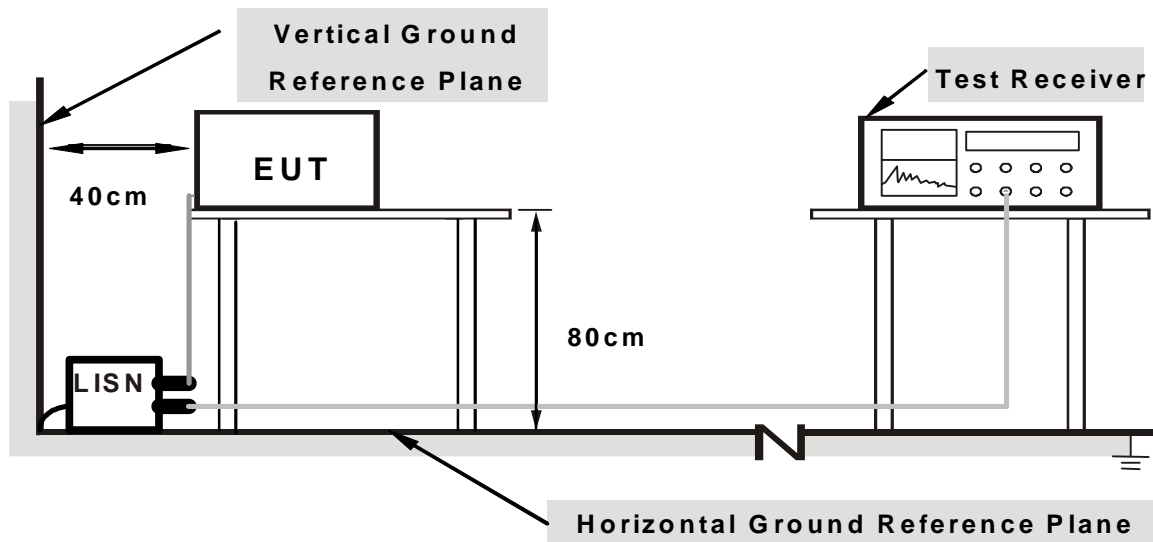

**Note: 1.Support units were connected to second LISN.**

**2.Both of LISNs (AMN) are 80 cm from EUT and at least 80 from other units and other metal planes**

For the actual test configuration, please refer to the related item – Photographs of the Test Configuration.

#### 4.1.6 EUT OPERATING CONDITIONS

1. Placed the EUT on testing table.
2. Controlling software (RT5x7xQA.exe) has been activated to set the EUT under transmission/receiving condition continuously.

#### 4.1.7 TEST RESULTS (MODE 1)

<b>PHASE</b>	Line (L)	<b>6dB BANDWIDTH</b>	9 kHz
--------------	----------	----------------------	-------

No	Freq. [MHz]	Corr. Factor (dB)	Reading Value [dB (uV)]		Emission Level [dB (uV)]		Limit [dB (uV)]		Margin (dB)	
			Q.P.	AV.	Q.P.	AV.	Q.P.	AV.	Q.P.	AV.
	<b>1</b>	<b>0.34531</b>	<b>0.10</b>	<b>49.27</b>	<b>48.13</b>	<b>49.37</b>	<b>48.23</b>	<b>59.07</b>	<b>49.07</b>	<b>-9.70</b>
2	0.94297	0.15	31.33	26.10	31.48	26.25	56.00	46.00	-24.52	-19.75
3	2.45313	0.30	33.60	29.03	33.90	29.33	56.00	46.00	-22.10	-16.67
4	3.76953	0.39	35.17	28.50	35.56	28.89	56.00	46.00	-20.44	-17.11
5	6.37500	0.52	34.87	27.83	35.39	28.35	60.00	50.00	-24.61	-21.65
6	8.94922	0.65	33.24	24.49	33.89	25.14	60.00	50.00	-26.11	-24.86

#### REMARKS:

1. Q.P. and AV. are abbreviations of quasi-peak and average individually.
2. The emission levels of other frequencies were very low against the limit.
3. Margin value = Emission level - Limit value
4. Correction factor = Insertion loss + Cable loss
5. Emission Level = Correction Factor + Reading Value.

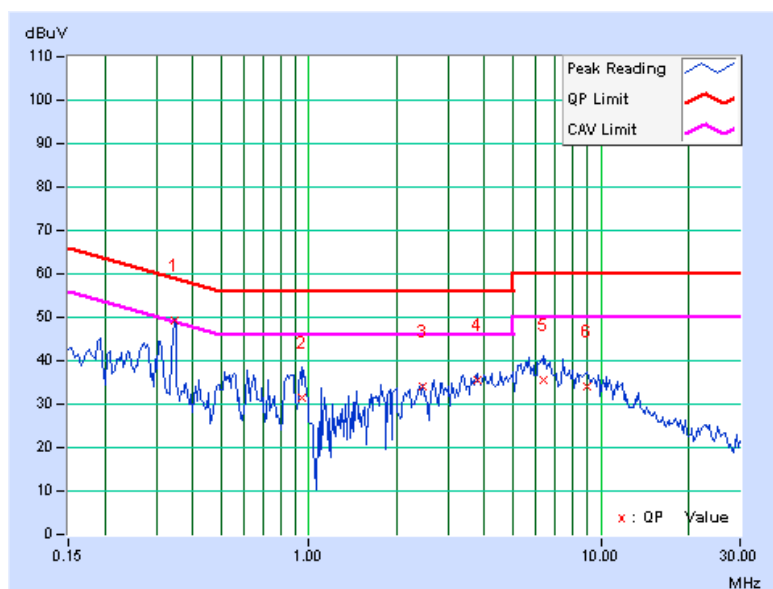

<b>PHASE</b>	Neutral (N)	<b>6dB BANDWIDTH</b>	9 kHz
--------------	-------------	----------------------	-------

No	Freq. [MHz]	Corr. Factor (dB)	Reading Value [dB (uV)]		Emission Level [dB (uV)]		Limit [dB (uV)]		Margin (dB)	
			Q.P.	AV.	Q.P.	AV.	Q.P.	AV.	Q.P.	AV.
	1	0.31016	0.09	42.80	42.75	42.89	42.84	59.97	49.97	-17.08
2	0.34531	0.09	47.02	46.56	47.11	46.65	59.07	49.07	-11.96	-2.42
3	0.92734	0.11	37.72	31.86	37.83	31.97	56.00	46.00	-18.17	-14.03
4	3.64453	0.29	34.08	25.45	34.37	25.74	56.00	46.00	-21.63	-20.26
5	6.15234	0.40	35.63	28.43	36.03	28.83	60.00	50.00	-23.97	-21.17
6	10.50000	0.60	29.60	21.59	30.20	22.19	60.00	50.00	-29.80	-27.81

**REMARKS:**

1. Q.P. and AV. are abbreviations of quasi-peak and average individually.
2. The emission levels of other frequencies were very low against the limit.
3. Margin value = Emission level - Limit value
4. Correction factor = Insertion loss + Cable loss
5. Emission Level = Correction Factor + Reading Value.

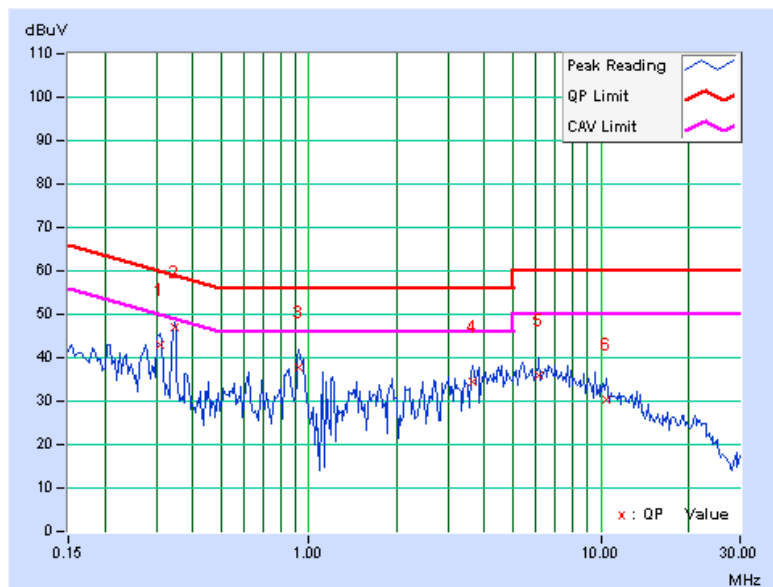

#### 4.1.8 TEST RESULTS (MODE 2)

<b>PHASE</b>	Line (L)	<b>6dB BANDWIDTH</b>	9 kHz
--------------	----------	----------------------	-------

No	Freq. [MHz]	Corr. Factor [dB]	Reading Value [dB (uV)]		Emission Level [dB (uV)]		Limit [dB (uV)]		Margin (dB)	
			Q.P.	AV.	Q.P.	AV.	Q.P.	AV.	Q.P.	AV.
	1	0.20078	0.06	47.16	39.38	47.22	39.44	63.58	53.58	-16.36
2	0.33750	0.07	37.21	29.19	37.28	29.26	59.26	49.26	-21.99	-20.01
3	0.52891	0.08	39.51	30.30	39.59	30.38	56.00	46.00	-16.41	-15.62
4	0.79453	0.10	38.30	30.17	38.40	30.27	56.00	46.00	-17.60	-15.73
5	2.98438	0.23	37.75	22.42	37.98	22.65	56.00	46.00	-18.02	-23.35
6	15.99609	0.54	38.36	25.37	38.90	25.91	60.00	50.00	-21.10	-24.09

#### REMARKS:

1. Q.P. and AV. are abbreviations of quasi-peak and average individually.
2. The emission levels of other frequencies were very low against the limit.
3. Margin value = Emission level - Limit value
4. Correction factor = Insertion loss + Cable loss
5. Emission Level = Correction Factor + Reading Value.

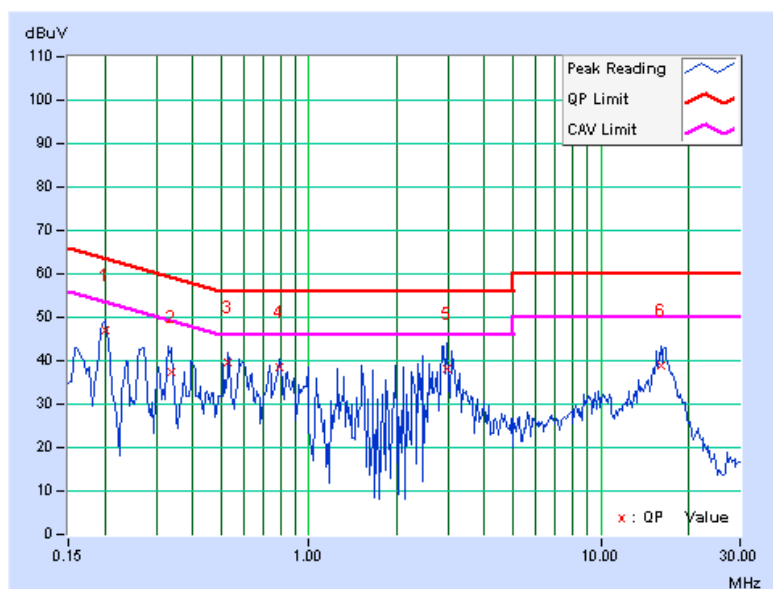

<b>PHASE</b>	Neutral (N)	<b>6dB BANDWIDTH</b>	9 kHz
--------------	-------------	----------------------	-------

No	Freq. [MHz]	Corr. Factor (dB)	Reading Value [dB (uV)]		Emission Level [dB (uV)]		Limit [dB (uV)]		Margin (dB)	
			Q.P.	AV.	Q.P.	AV.	Q.P.	AV.	Q.P.	AV.
	1	0.19687	0.07	48.99	40.33	49.06	40.40	63.74	53.74	-14.68
2	0.27891	0.07	36.80	26.20	36.87	26.27	60.85	50.85	-23.97	-24.57
3	0.59531	0.09	38.25	33.63	38.34	33.72	56.00	46.00	-17.66	-12.28
4	0.79453	0.11	36.49	30.21	36.60	30.32	56.00	46.00	-19.40	-15.68
5	2.82813	0.21	34.41	24.16	34.62	24.37	56.00	46.00	-21.38	-21.63
6	15.83984	0.52	34.53	22.99	35.05	23.51	60.00	50.00	-24.95	-26.49

**REMARKS:**

1. Q.P. and AV. are abbreviations of quasi-peak and average individually.
2. The emission levels of other frequencies were very low against the limit.
3. Margin value = Emission level - Limit value
4. Correction factor = Insertion loss + Cable loss
5. Emission Level = Correction Factor + Reading Value.

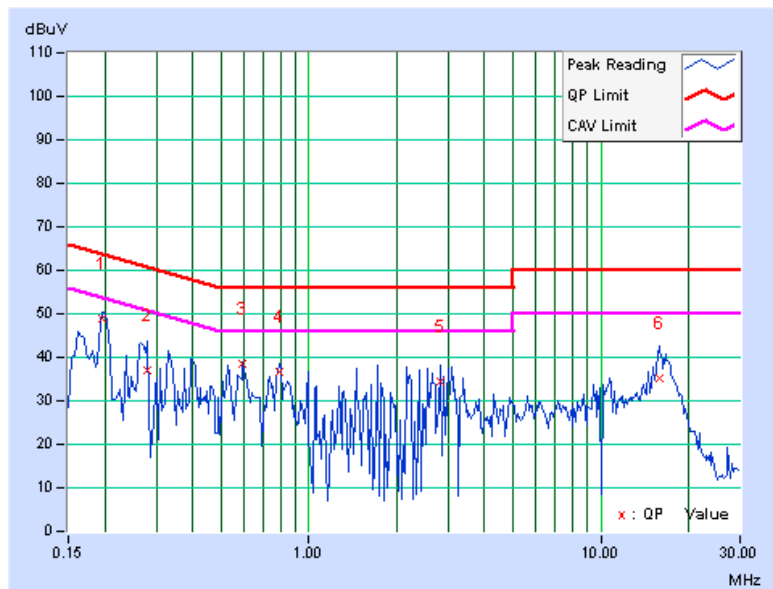

## 4.2 RADIATED EMISSION AND BANDEDGE MEASUREMENT

### 4.2.1 LIMITS OF RADIATED EMISSION AND BANDEDGE MEASUREMENT

Radiated emissions which fall in the restricted bands must comply with the radiated emission limits specified as below table. Other emissions shall be at least 20dB below the highest level of the desired power:

Frequencies (MHz)	Field strength (microvolts/meter)	Measurement distance (meters)
0.009-0.490	2400/F(kHz)	300
0.490-1.705	24000/F(kHz)	30
1.705-30.0	30	30
30-88	100	3
88-216	150	3
216-960	200	3
Above 960	500	3

**NOTE:**

1. The lower limit shall apply at the transition frequencies.
2. Emission level (dBuV/m) = 20 log Emission level (uV/m).
3. For frequencies above 1000MHz, the field strength limits are based on average detector, however, the peak field strength of any emission shall not exceed the maximum permitted average limits, specified above by more than 20dB under any condition of modulation.



A D T

#### 4.2.2 TEST INSTRUMENTS

DESCRIPTION & MANUFACTURER	MODEL NO.	SERIAL NO.	CALIBRATED DATE	CALIBRATED UNTIL
Agilent Spectrum Analyzer	E4446A	MY48250253	Aug. 29, 2011	Aug. 28, 2012
Agilent Pre-Selector	N9039A	MY46520310	Aug. 29, 2011	Aug. 28, 2012
Agilent Signal Generator	N5181A	MY49060347	July 25, 2011	July 24, 2012
Mini-Circuits Pre-Amplifier	ZFL-1000VH2B	AMP-ZFL-04	Nov. 15, 2011	Nov. 14, 2012
Agilent Pre-Amplifier	8449B	3008A02465	Feb. 27, 2012	Feb. 26, 2013
SPACEK LABS	SLKKa-48-6	9K16	Nov. 15, 2011	Nov. 14, 2012
SCHWARZBECK Trilog Broadband Antenna	VULB 9168	9168-361	Apr. 06, 2012	Apr. 05, 2013
AISI Horn_Antenna	AIH.8018	0000220091110	Nov. 23, 2011	Nov. 22, 2012
SCHWARZBECK Horn_Antenna	BBHA 9170	9170-424	Oct. 07, 2011	Oct. 06, 2012
RF CABLE	NA	RF104-205 RF104-207 RF104-202	Dec. 27, 2011	Dec. 26, 2012
RF Cable	NA	CHHCAB_001	Oct. 08, 2011	Oct. 07, 2012
Software	ADT_Radiated_V8.7.05	NA	NA	NA
CT Antenna Tower & Turn Table	NA	NA	NA	NA

**Note:**

1. The calibration interval of the above test instruments is 12 months and the calibrations are traceable to NML/ROC and NIST/USA.
2. The horn antenna, preamplifier (model: 8449B) are used only for the measurement of emission frequency above 1GHz if tested.
- 3 The test was performed in 966 Chamber No. H.
4. The FCC Site Registration No. is 797305.
- 5 The CANADA Site Registration No. is IC 7450H-3.
- 6 Tested Date: May 10 to 22, 2012



#### 4.2.3 TEST PROCEDURES

- a. The EUT was placed on the top of a rotating table 0.8 meters above the ground at a 3 meters chamber room. The table was rotated 360 degrees to determine the position of the highest radiation.
- b. The EUT was set 3 meters away from the interference-receiving antenna, which was mounted on the top of a variable-height antenna tower.
- c. The height of antenna is varied from one meter to four meters above the ground to determine the maximum value of the field strength. Both horizontal and vertical polarizations of the antenna are set to make the measurement.
- d. For each suspected emission, the EUT was arranged to its worst case and then the antenna was tuned to heights from 1 meter to 4 meters and the rotatable table was turned from 0 degrees to 360 degrees to find the maximum reading.
- e. The test-receiver system was set to quasi-peak detect function and specified bandwidth with maximum hold mode when the test frequency is below 1 GHz.
- f. The test-receiver system was set to peak and average detect function and specified bandwidth with maximum hold mode when the test frequency is above 1 GHz. If the peak reading value also meets average limit, measurement with the average detector is unnecessary.

**NOTE:**

1. The resolution bandwidth and video bandwidth of test receiver/spectrum analyzer is 120kHz for Quasi-peak detection (QP) at frequency below 1GHz.
2. The resolution bandwidth of test receiver/spectrum analyzer is 1 MHz and the video bandwidth is 3 MHz for Peak detection (PK) at frequency above 1GHz.
3. The resolution bandwidth of test receiver/spectrum analyzer is 1 MHz and the video bandwidth is 10 Hz for Average detection (AV) at frequency above 1GHz.
4. All modes of operation were investigated and the worst-case emissions are reported.

#### 4.2.4 DEVIATION FROM TEST STANDARD

No deviation

#### 4.2.5 TEST SETUP

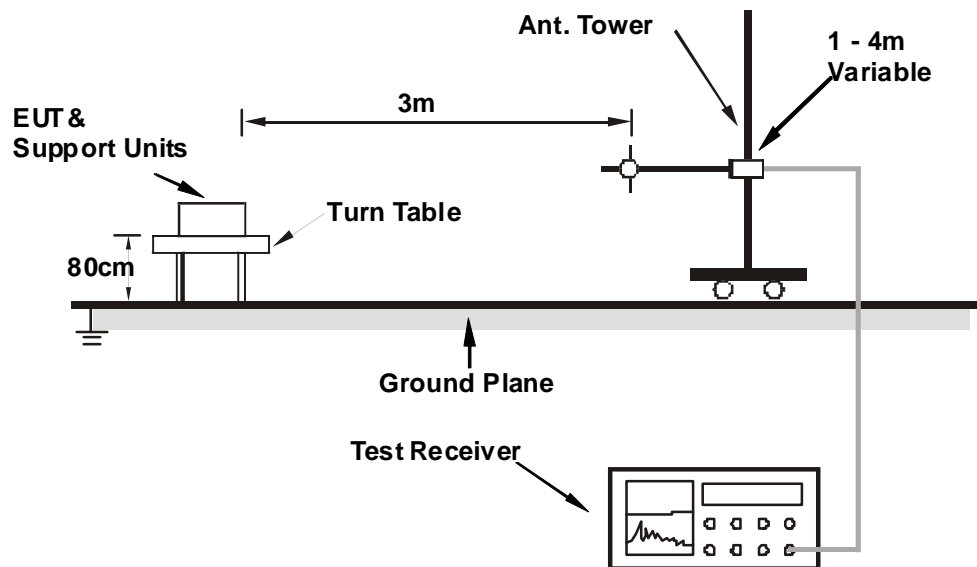

For the actual test configuration, please refer to the related item – Photographs of the Test Configuration.

#### 4.2.6 EUT OPERATING CONDITIONS

Same as 4.1.6

## 4.2.7 TEST RESULTS

### BELOW 1GHz WORST-CASE DATA

#### 802.11n (20MHz)

<b>CHANNEL</b>	TX Channel 1	<b>DETECTOR FUNCTION</b>	Quasi-Peak (QP)
<b>FREQUENCY RANGE</b>	Below 1GHz		

ANTENNA POLARITY & TEST DISTANCE: HORIZONTAL AT 3 M								
NO.	FREQ. (MHz)	EMISSION LEVEL (dBuV/m)	LIMIT (dBuV/m)	MARGIN (dB)	ANTENNA HEIGHT (m)	TABLE ANGLE (Degree)	RAW VALUE (dBuV)	CORRECTION FACTOR (dB/m)
1	200.05	35.5 QP	43.5	-8.0	1.50 H	295	24.45	11.02
2	324.02	43.6 QP	46.0	-2.4	1.00 H	327	27.75	15.86
3	400.07	33.7 QP	46.0	-12.3	1.00 H	324	15.96	17.70
4	478.94	35.2 QP	46.0	-10.8	1.75 H	35	15.65	19.54
5	799.99	41.3 QP	46.0	-4.7	1.00 H	175	15.69	25.62
6	837.05	39.9 QP	46.0	-6.1	1.00 H	27	13.82	26.11
ANTENNA POLARITY & TEST DISTANCE: VERTICAL AT 3 M								
NO.	FREQ. (MHz)	EMISSION LEVEL (dBuV/m)	LIMIT (dBuV/m)	MARGIN (dB)	ANTENNA HEIGHT (m)	TABLE ANGLE (Degree)	RAW VALUE (dBuV)	CORRECTION FACTOR (dB/m)
1	33.01	37.3 QP	40.0	-2.7	1.25 V	242	24.29	13.03
2	230.84	31.3 QP	46.0	-14.7	1.00 V	85	18.91	12.43
3	324.04	36.5 QP	46.0	-9.5	1.50 V	28	20.64	15.86
4	400.07	33.2 QP	46.0	-12.8	1.50 V	73	15.53	17.70
5	480.95	32.6 QP	46.0	-13.4	1.75 V	356	13.01	19.58
6	799.98	39.8 QP	46.0	-6.2	1.50 V	360	14.20	25.62
7	959.97	36.6 QP	46.0	-9.4	1.25 V	242	8.58	27.98

#### REMARKS:

1. Emission level (dBuV/m) = Raw Value (dBuV) + Correction Factor (dB/m).
2. Correction Factor (dB/m) = Antenna Factor (dB/m) + Cable Factor (dB).
3. The other emission levels were very low against the limit.
4. Margin value = Emission level – Limit value.



A D T

ABOVE 1GHz DATA

802.11b

<b>CHANNEL</b>	TX Channel 1	<b>DETECTOR FUNCTION</b>	Peak (PK)
<b>FREQUENCY RANGE</b>	1GHz ~ 25GHz		Average (AV)

**ANTENNA POLARITY & TEST DISTANCE: HORIZONTAL AT 3 M**

NO.	FREQ. (MHz)	EMISSION LEVEL (dBuV/m)	LIMIT (dBuV/m)	MARGIN (dB)	ANTENNA HEIGHT (m)	TABLE ANGLE (Degree)	RAW VALUE (dBuV)	CORRECTION FACTOR (dB/m)
1	2390.00	58.3 PK	74.0	-15.7	1.46 H	333	27.09	31.21
2	2390.00	46.2 AV	54.0	-7.8	1.46 H	333	14.99	31.21
3	*2412.00	107.3 PK			1.41 H	333	76.03	31.27
4	*2412.00	104.9 AV			1.41 H	333	73.63	31.27
5	4824.00	56.5 PK	74.0	-17.5	1.33 H	332	17.08	39.42
6	4824.00	53.1 AV	54.0	-0.9	1.33 H	332	13.68	39.42

**ANTENNA POLARITY & TEST DISTANCE: VERTICAL AT 3 M**

NO.	FREQ. (MHz)	EMISSION LEVEL (dBuV/m)	LIMIT (dBuV/m)	MARGIN (dB)	ANTENNA HEIGHT (m)	TABLE ANGLE (Degree)	RAW VALUE (dBuV)	CORRECTION FACTOR (dB/m)
1	2390.00	57.1 PK	74.0	-16.9	1.02 V	360	25.89	31.21
2	2390.00	44.8 AV	54.0	-9.2	1.02 V	360	13.59	31.21
3	*2412.00	100.2 PK			1.02 V	360	68.88	31.27
4	*2412.00	97.7 AV			1.02 V	360	66.43	31.27
5	4824.00	52.9 PK	74.0	-21.1	1.22 V	271	13.48	39.42
6	4824.00	48.2 AV	54.0	-5.8	1.22 V	271	8.78	39.42

**REMARKS:**

1. Emission level (dBuV/m) = Raw Value (dBuV) + Correction Factor (dB/m).
2. Correction Factor (dB/m) = Antenna Factor (dB/m) + Cable Factor (dB).
3. The other emission levels were very low against the limit.
4. Margin value = Emission level – Limit value.
5. " \* ": Fundamental frequency.



A D T

<b>CHANNEL</b>	TX Channel 6	<b>DETECTOR FUNCTION</b>	Peak (PK)
<b>FREQUENCY RANGE</b>	1GHz ~ 25GHz		Average (AV)

**ANTENNA POLARITY & TEST DISTANCE: HORIZONTAL AT 3 M**

NO.	FREQ. (MHz)	EMISSION LEVEL (dBuV/m)	LIMIT (dBuV/m)	MARGIN (dB)	ANTENNA HEIGHT (m)	TABLE ANGLE (Degree)	RAW VALUE (dBuV)	CORRECTION FACTOR (dB/m)
1	*2437.00	106.6 PK			1.47 H	331	75.26	31.34
2	*2437.00	104.6 AV			1.47 H	331	73.26	31.34
3	4874.00	56.4 PK	74.0	-17.6	1.31 H	20	16.78	39.62
4	<b>4874.00</b>	<b>53.5 AV</b>	<b>54.0</b>	<b>-0.5</b>	<b>1.31 H</b>	<b>20</b>	<b>13.88</b>	<b>39.62</b>
5	7311.00	54.5 PK	74.0	-19.5	1.08 H	260	10.40	44.10
6	7311.00	42.7 AV	54.0	-11.3	1.08 H	260	-1.40	44.10

**ANTENNA POLARITY & TEST DISTANCE: VERTICAL AT 3 M**

NO.	FREQ. (MHz)	EMISSION LEVEL (dBuV/m)	LIMIT (dBuV/m)	MARGIN (dB)	ANTENNA HEIGHT (m)	TABLE ANGLE (Degree)	RAW VALUE (dBuV)	CORRECTION FACTOR (dB/m)
1	*2437.00	99.5 PK			1.03 V	360	68.16	31.34
2	*2437.00	97.2 AV			1.03 V	360	65.81	31.34
3	4874.00	53.8 PK	74.0	-20.2	1.20 V	262	14.18	39.62
4	4874.00	49.6 AV	54.0	-4.4	1.20 V	262	9.98	39.62
5	7311.00	55.0 PK	74.0	-19.0	1.21 V	239	10.90	44.10
6	7311.00	42.8 AV	54.0	-11.2	1.21 V	239	-1.30	44.10

**REMARKS:**

1. Emission level (dBuV/m) = Raw Value (dBuV) + Correction Factor (dB/m).
2. Correction Factor (dB/m) = Antenna Factor (dB/m) + Cable Factor (dB).
3. The other emission levels were very low against the limit.
4. Margin value = Emission level – Limit value.
5. " \* ": Fundamental frequency.



A D T

<b>CHANNEL</b>	TX Channel 11	<b>DETECTOR FUNCTION</b>	Peak (PK)
<b>FREQUENCY RANGE</b>	1GHz ~ 25GHz		Average (AV)

**ANTENNA POLARITY & TEST DISTANCE: HORIZONTAL AT 3 M**

NO.	FREQ. (MHz)	EMISSION LEVEL (dBuV/m)	LIMIT (dBuV/m)	MARGIN (dB)	ANTENNA HEIGHT (m)	TABLE ANGLE (Degree)	RAW VALUE (dBuV)	CORRECTION FACTOR (dB/m)
1	*2462.00	105.6 PK			1.43 H	356	74.20	31.40
2	*2462.00	103.7 AV			1.43 H	356	72.30	31.40
3	2483.50	60.3 PK	74.0	-13.7	1.43 H	356	28.84	31.46
4	2483.50	51.5 AV	54.0	-2.5	1.43 H	356	20.04	31.46
5	4924.00	56.0 PK	74.0	-18.0	1.26 H	20	16.18	39.82
6	4924.00	52.5 AV	54.0	-1.5	1.26 H	20	12.68	39.82
7	7386.00	54.5 PK	74.0	-19.5	1.08 H	270	10.32	44.18
8	7386.00	42.8 AV	54.0	-11.2	1.08 H	270	-1.38	44.18

**ANTENNA POLARITY & TEST DISTANCE: VERTICAL AT 3 M**

NO.	FREQ. (MHz)	EMISSION LEVEL (dBuV/m)	LIMIT (dBuV/m)	MARGIN (dB)	ANTENNA HEIGHT (m)	TABLE ANGLE (Degree)	RAW VALUE (dBuV)	CORRECTION FACTOR (dB/m)
1	*2462.00	98.0 PK			1.07 V	359	66.60	31.40
2	*2462.00	95.3 AV			1.07 V	359	63.90	31.40
3	2483.50	57.6 PK	74.0	-16.4	1.00 V	360	26.14	31.46
4	2483.50	44.4 AV	54.0	-9.6	1.00 V	360	12.94	31.46
5	4924.00	54.7 PK	74.0	-19.3	1.16 V	269	14.88	39.82
6	4924.00	50.4 AV	54.0	-3.6	1.16 V	269	10.58	39.82
7	7386.00	55.2 PK	74.0	-18.8	1.21 V	224	11.02	44.18
8	7386.00	43.1 AV	54.0	-10.9	1.21 V	224	-1.08	44.18

**REMARKS:**

1. Emission level (dBuV/m) = Raw Value (dBuV) + Correction Factor (dB/m).
2. Correction Factor (dB/m) = Antenna Factor (dB/m) + Cable Factor (dB).
3. The other emission levels were very low against the limit.
4. Margin value = Emission level – Limit value.
5. " \* ": Fundamental frequency.



A D T

802.11g

<b>CHANNEL</b>	TX Channel 1	<b>DETECTOR FUNCTION</b>	Peak (PK)
<b>FREQUENCY RANGE</b>	1GHz ~ 25GHz		Average (AV)

**ANTENNA POLARITY & TEST DISTANCE: HORIZONTAL AT 3 M**

NO.	FREQ. (MHz)	EMISSION LEVEL (dBuV/m)	LIMIT (dBuV/m)	MARGIN (dB)	ANTENNA HEIGHT (m)	TABLE ANGLE (Degree)	RAW VALUE (dBuV)	CORRECTION FACTOR (dB/m)
1	2390.00	68.4 PK	74.0	-5.6	1.49 H	326	36.21	32.19
2	2390.00	53.4 AV	54.0	-0.6	1.49 H	326	21.21	32.19
3	*2412.00	109.2 PK			1.43 H	338	76.95	32.25
4	*2412.00	99.1 AV			1.43 H	338	66.85	32.25
5	4824.00	51.9 PK	74.0	-22.1	1.35 H	324	10.33	41.57
6	4824.00	39.8 AV	54.0	-14.2	1.35 H	324	-1.77	41.57

**ANTENNA POLARITY & TEST DISTANCE: VERTICAL AT 3 M**

NO.	FREQ. (MHz)	EMISSION LEVEL (dBuV/m)	LIMIT (dBuV/m)	MARGIN (dB)	ANTENNA HEIGHT (m)	TABLE ANGLE (Degree)	RAW VALUE (dBuV)	CORRECTION FACTOR (dB/m)
1	2390.00	59.7 PK	74.0	-14.3	1.10 V	157	27.51	32.19
2	2390.00	46.9 AV	54.0	-7.1	1.10 V	157	14.71	32.19
3	*2412.00	98.7 PK			1.09 V	156	66.45	32.25
4	*2412.00	89.1 AV			1.09 V	156	56.85	32.25
5	4824.00	56.2 PK	74.0	-17.8	1.21 V	188	14.63	41.57
6	4824.00	42.5 AV	54.0	-11.5	1.21 V	188	0.93	41.57

**REMARKS:**

1. Emission level (dBuV/m) = Raw Value (dBuV) + Correction Factor (dB/m).
2. Correction Factor (dB/m) = Antenna Factor (dB/m) + Cable Factor (dB).
3. The other emission levels were very low against the limit.
4. Margin value = Emission level – Limit value.
5. " \* ": Fundamental frequency.



A D T

<b>CHANNEL</b>	TX Channel 6	<b>DETECTOR FUNCTION</b>	Peak (PK)
<b>FREQUENCY RANGE</b>	1GHz ~ 25GHz		Average (AV)

**ANTENNA POLARITY & TEST DISTANCE: HORIZONTAL AT 3 M**

NO.	FREQ. (MHz)	EMISSION LEVEL (dBuV/m)	LIMIT (dBuV/m)	MARGIN (dB)	ANTENNA HEIGHT (m)	TABLE ANGLE (Degree)	RAW VALUE (dBuV)	CORRECTION FACTOR (dB/m)
1	*2437.00	112.4 PK			1.48 H	337	80.09	32.31
2	*2437.00	102.7 AV			1.48 H	337	70.39	32.31
3	4874.00	63.4 PK	74.0	-10.6	1.29 H	335	21.74	41.66
4	4874.00	52.7 AV	54.0	-1.3	1.29 H	335	11.04	41.66
5	7311.00	54.5 PK	74.0	-19.5	1.03 H	260	8.36	46.14
6	7311.00	43.1 AV	54.0	-10.9	1.03 H	260	-3.04	46.14

**ANTENNA POLARITY & TEST DISTANCE: VERTICAL AT 3 M**

NO.	FREQ. (MHz)	EMISSION LEVEL (dBuV/m)	LIMIT (dBuV/m)	MARGIN (dB)	ANTENNA HEIGHT (m)	TABLE ANGLE (Degree)	RAW VALUE (dBuV)	CORRECTION FACTOR (dB/m)
1	*2437.00	104.5 PK			1.01 V	360	72.19	32.31
2	*2437.00	95.0 AV			1.01 V	360	62.64	32.31
3	4874.00	58.2 PK	74.0	-15.8	1.26 V	197	16.54	41.66
4	4874.00	47.9 AV	54.0	-6.1	1.26 V	197	6.24	41.66
5	7311.00	55.0 PK	74.0	-19.0	1.24 V	217	8.86	46.14
6	7311.00	42.9 AV	54.0	-11.1	1.24 V	217	-3.24	46.14

**REMARKS:**

1. Emission level (dBuV/m) = Raw Value (dBuV) + Correction Factor (dB/m).
2. Correction Factor (dB/m) = Antenna Factor (dB/m) + Cable Factor (dB).
3. The other emission levels were very low against the limit.
4. Margin value = Emission level – Limit value.
5. " \* " : Fundamental frequency.





A D T

<b>CHANNEL</b>	TX Channel 11	<b>DETECTOR FUNCTION</b>	Peak (PK)
<b>FREQUENCY RANGE</b>	1GHz ~ 25GHz		Average (AV)

**ANTENNA POLARITY & TEST DISTANCE: HORIZONTAL AT 3 M**

NO.	FREQ. (MHz)	EMISSION LEVEL (dBuV/m)	LIMIT (dBuV/m)	MARGIN (dB)	ANTENNA HEIGHT (m)	TABLE ANGLE (Degree)	RAW VALUE (dBuV)	CORRECTION FACTOR (dB/m)
1	*2462.00	107.3 PK			1.44 H	325	74.93	32.37
2	*2462.00	96.9 AV			1.44 H	325	64.53	32.37
3	2483.50	69.1 PK	74.0	-4.9	1.44 H	328	36.67	32.43
4	2483.50	52.7 AV	54.0	-1.3	1.44 H	328	20.27	32.43
5	4924.00	48.5 PK	74.0	-25.5	1.48 H	328	6.80	41.70
6	4924.00	37.0 AV	54.0	-17.0	1.48 H	328	-4.70	41.70
7	7386.00	54.2 PK	74.0	-19.8	1.00 H	255	7.87	46.33
8	7386.00	42.7 AV	54.0	-11.3	1.00 H	255	-3.63	46.33

**ANTENNA POLARITY & TEST DISTANCE: VERTICAL AT 3 M**

NO.	FREQ. (MHz)	EMISSION LEVEL (dBuV/m)	LIMIT (dBuV/m)	MARGIN (dB)	ANTENNA HEIGHT (m)	TABLE ANGLE (Degree)	RAW VALUE (dBuV)	CORRECTION FACTOR (dB/m)
1	*2462.00	97.4 PK			1.00 V	360	65.03	32.37
2	*2462.00	88.2 AV			1.00 V	360	55.83	32.37
3	2483.50	61.8 PK	74.0	-12.2	1.00 V	360	29.37	32.43
4	2483.50	45.2 AV	54.0	-8.8	1.00 V	360	12.77	32.43
5	4924.00	57.0 PK	74.0	-17.0	1.17 V	196	15.30	41.70
6	4924.00	43.5 AV	54.0	-10.5	1.17 V	196	1.80	41.70
7	7386.00	54.8 PK	74.0	-19.2	1.26 V	219	8.47	46.33
8	7386.00	42.7 AV	54.0	-11.3	1.26 V	219	-3.63	46.33

**REMARKS:**

1. Emission level (dBuV/m) = Raw Value (dBuV) + Correction Factor (dB/m).
2. Correction Factor (dB/m) = Antenna Factor (dB/m) + Cable Factor (dB).
3. The other emission levels were very low against the limit.
4. Margin value = Emission level – Limit value.
5. " \* ": Fundamental frequency.



A D T

802.11n (20MHz)

<b>CHANNEL</b>	TX Channel 1	<b>DETECTOR FUNCTION</b>	Peak (PK)
<b>FREQUENCY RANGE</b>	1GHz ~ 25GHz		Average (AV)

**ANTENNA POLARITY & TEST DISTANCE: HORIZONTAL AT 3 M**

NO.	FREQ. (MHz)	EMISSION LEVEL (dBuV/m)	LIMIT (dBuV/m)	MARGIN (dB)	ANTENNA HEIGHT (m)	TABLE ANGLE (Degree)	RAW VALUE (dBuV)	CORRECTION FACTOR (dB/m)
1	2390.00	71.4 PK	74.0	-2.6	1.49 H	326	39.21	32.19
2	2390.00	52.0 AV	54.0	-2.0	1.49 H	326	19.81	32.19
3	*2412.00	106.4 PK			1.48 H	327	74.15	32.25
4	*2412.00	97.1 AV			1.48 H	327	64.85	32.25
5	4824.00	52.3 PK	74.0	-21.7	1.41 H	331	10.73	41.57
6	4824.00	40.2 AV	54.0	-13.8	1.41 H	331	-1.37	41.57

**ANTENNA POLARITY & TEST DISTANCE: VERTICAL AT 3 M**

NO.	FREQ. (MHz)	EMISSION LEVEL (dBuV/m)	LIMIT (dBuV/m)	MARGIN (dB)	ANTENNA HEIGHT (m)	TABLE ANGLE (Degree)	RAW VALUE (dBuV)	CORRECTION FACTOR (dB/m)
1	2390.00	59.9 PK	74.0	-14.1	1.02 V	360	27.71	32.19
2	2390.00	46.2 AV	54.0	-7.8	1.02 V	360	14.01	32.19
3	*2412.00	99.7 PK			1.02 V	360	67.45	32.25
4	*2412.00	91.3 AV			1.02 V	360	59.05	32.25
5	4824.00	56.5 PK	74.0	-17.5	1.24 V	181	14.93	41.57
6	4824.00	42.8 AV	54.0	-11.2	1.24 V	181	1.23	41.57

**REMARKS:**

1. Emission level (dBuV/m) = Raw Value (dBuV) + Correction Factor (dB/m).
2. Correction Factor (dB/m) = Antenna Factor (dB/m) + Cable Factor (dB).
3. The other emission levels were very low against the limit.
4. Margin value = Emission level – Limit value.
5. " \* ": Fundamental frequency.



A D T

<b>CHANNEL</b>	TX Channel 6	<b>DETECTOR FUNCTION</b>	Peak (PK)
<b>FREQUENCY RANGE</b>	1GHz ~ 25GHz		Average (AV)

**ANTENNA POLARITY & TEST DISTANCE: HORIZONTAL AT 3 M**

NO.	FREQ. (MHz)	EMISSION LEVEL (dBuV/m)	LIMIT (dBuV/m)	MARGIN (dB)	ANTENNA HEIGHT (m)	TABLE ANGLE (Degree)	RAW VALUE (dBuV)	CORRECTION FACTOR (dB/m)
1	*2437.00	113.6 PK			1.46 H	334	81.29	32.31
2	*2437.00	104.3 AV			1.46 H	334	71.99	32.31
3	4874.00	68.6 PK	74.0	-5.4	1.42 H	328	26.94	41.66
4	4874.00	53.3 AV	54.0	-0.7	1.42 H	328	11.64	41.66
5	7311.00	54.0 PK	74.0	-20.0	1.04 H	241	7.86	46.14
6	7311.00	42.6 AV	54.0	-11.4	1.04 H	241	-3.54	46.14

**ANTENNA POLARITY & TEST DISTANCE: VERTICAL AT 3 M**

NO.	FREQ. (MHz)	EMISSION LEVEL (dBuV/m)	LIMIT (dBuV/m)	MARGIN (dB)	ANTENNA HEIGHT (m)	TABLE ANGLE (Degree)	RAW VALUE (dBuV)	CORRECTION FACTOR (dB/m)
1	*2437.00	105.1 PK			1.00 V	360	72.79	32.31
2	*2437.00	95.9 AV			1.00 V	360	63.59	32.31
3	4874.00	58.6 PK	74.0	-15.4	1.24 V	188	16.94	41.66
4	4874.00	48.2 AV	54.0	-5.8	1.24 V	188	6.54	41.66
5	7311.00	55.3 PK	74.0	-18.7	1.28 V	211	9.16	46.14
6	7311.00	43.4 AV	54.0	-10.6	1.28 V	211	-2.74	46.14

**REMARKS:**

1. Emission level (dBuV/m) = Raw Value (dBuV) + Correction Factor (dB/m).
2. Correction Factor (dB/m) = Antenna Factor (dB/m) + Cable Factor (dB).
3. The other emission levels were very low against the limit.
4. Margin value = Emission level – Limit value.
5. " \* ": Fundamental frequency.



A D T

<b>CHANNEL</b>	TX Channel 11	<b>DETECTOR FUNCTION</b>	Peak (PK)
<b>FREQUENCY RANGE</b>	1GHz ~ 25GHz		Average (AV)

**ANTENNA POLARITY & TEST DISTANCE: HORIZONTAL AT 3 M**

NO.	FREQ. (MHz)	EMISSION LEVEL (dBuV/m)	LIMIT (dBuV/m)	MARGIN (dB)	ANTENNA HEIGHT (m)	TABLE ANGLE (Degree)	RAW VALUE (dBuV)	CORRECTION FACTOR (dB/m)
1	*2462.00	104.8 PK			1.45 H	326	72.43	32.37
2	*2462.00	95.8 AV			1.45 H	326	63.43	32.37
3	2483.50	69.1 PK	74.0	-4.9	1.42 H	329	36.67	32.43
4	2483.50	52.7 AV	54.0	-1.3	1.42 H	329	20.27	32.43
5	4924.00	49.2 PK	74.0	-24.8	1.42 H	330	7.50	41.70
6	4924.00	37.5 AV	54.0	-16.5	1.42 H	330	-4.20	41.70
7	7386.00	53.6 PK	74.0	-20.4	1.00 H	244	7.27	46.33
8	7386.00	42.3 AV	54.0	-11.7	1.00 H	244	-4.03	46.33

**ANTENNA POLARITY & TEST DISTANCE: VERTICAL AT 3 M**

NO.	FREQ. (MHz)	EMISSION LEVEL (dBuV/m)	LIMIT (dBuV/m)	MARGIN (dB)	ANTENNA HEIGHT (m)	TABLE ANGLE (Degree)	RAW VALUE (dBuV)	CORRECTION FACTOR (dB/m)
1	*2462.00	99.2 PK			1.00 V	360	66.83	32.37
2	*2462.00	90.3 AV			1.00 V	360	57.93	32.37
3	2483.50	61.2 PK	74.0	-12.8	1.00 V	360	28.77	32.43
4	2483.50	45.3 AV	54.0	-8.7	1.00 V	360	12.87	32.43
5	4924.00	56.8 PK	74.0	-17.2	1.23 V	189	15.10	41.70
6	4924.00	43.1 AV	54.0	-10.9	1.23 V	189	1.40	41.70
7	7386.00	54.9 PK	74.0	-19.1	1.31 V	198	8.57	46.33
8	7386.00	43.1 AV	54.0	-10.9	1.31 V	198	-3.23	46.33

**REMARKS:**

1. Emission level (dBuV/m) = Raw Value (dBuV) + Correction Factor (dB/m).
2. Correction Factor (dB/m) = Antenna Factor (dB/m) + Cable Factor (dB).
3. The other emission levels were very low against the limit.
4. Margin value = Emission level – Limit value.
5. " \* " : Fundamental frequency.



A D T

802.11n (40MHz)

<b>CHANNEL</b>	TX Channel 3	<b>DETECTOR FUNCTION</b>	Peak (PK)
<b>FREQUENCY RANGE</b>	1GHz ~ 25GHz		Average (AV)

**ANTENNA POLARITY & TEST DISTANCE: HORIZONTAL AT 3 M**

NO.	FREQ. (MHz)	EMISSION LEVEL (dBuV/m)	LIMIT (dBuV/m)	MARGIN (dB)	ANTENNA HEIGHT (m)	TABLE ANGLE (Degree)	RAW VALUE (dBuV)	CORRECTION FACTOR (dB/m)
1	2390.00	72.6 PK	74.0	-1.4	1.51 H	326	40.41	32.19
2	2390.00	53.1 AV	54.0	-0.9	1.51 H	326	20.91	32.19
3	*2422.00	102.6 PK			1.53 H	154	70.33	32.27
4	*2422.00	92.9 AV			1.53 H	154	60.63	32.27
5	4844.00	52.1 PK	74.0	-21.9	1.08 H	179	10.49	41.61
6	4844.00	40.5 AV	54.0	-13.5	1.08 H	179	-1.11	41.61
7	7266.00	51.4 PK	74.0	-22.6	1.24 H	236	5.38	46.02
8	7266.00	41.6 AV	54.0	-12.4	1.24 H	236	-4.42	46.02

**ANTENNA POLARITY & TEST DISTANCE: VERTICAL AT 3 M**

NO.	FREQ. (MHz)	EMISSION LEVEL (dBuV/m)	LIMIT (dBuV/m)	MARGIN (dB)	ANTENNA HEIGHT (m)	TABLE ANGLE (Degree)	RAW VALUE (dBuV)	CORRECTION FACTOR (dB/m)
1	2390.00	61.2 PK	74.0	-12.8	1.00 V	360	29.01	32.19
2	2390.00	45.1 AV	54.0	-8.9	1.00 V	360	12.91	32.19
3	*2422.00	96.7 PK			1.00 V	360	64.43	32.27
4	*2422.00	87.8 AV			1.00 V	360	55.53	32.27
5	4844.00	50.1 PK	74.0	-23.9	1.28 V	176	8.49	41.61
6	4844.00	38.8 AV	54.0	-15.2	1.28 V	176	-2.81	41.61
7	7266.00	55.5 PK	74.0	-18.5	1.26 V	216	9.48	46.02
8	7266.00	43.4 AV	54.0	-10.6	1.26 V	216	-2.62	46.02

**REMARKS:**

1. Emission level (dBuV/m) = Raw Value (dBuV) + Correction Factor (dB/m).
2. Correction Factor (dB/m) = Antenna Factor (dB/m) + Cable Factor (dB).
3. The other emission levels were very low against the limit.
4. Margin value = Emission level – Limit value.
5. " \* ": Fundamental frequency.



A D T

<b>CHANNEL</b>	TX Channel 6	<b>DETECTOR FUNCTION</b>	Peak (PK)
<b>FREQUENCY RANGE</b>	1GHz ~ 25GHz		Average (AV)

**ANTENNA POLARITY & TEST DISTANCE: HORIZONTAL AT 3 M**

NO.	FREQ. (MHz)	EMISSION LEVEL (dBuV/m)	LIMIT (dBuV/m)	MARGIN (dB)	ANTENNA HEIGHT (m)	TABLE ANGLE (Degree)	RAW VALUE (dBuV)	CORRECTION FACTOR (dB/m)
1	2390.00	64.6 PK	74.0	-9.4	1.42 H	326	32.41	32.19
2	2390.00	49.9 AV	54.0	-4.1	1.42 H	326	17.71	32.19
3	*2437.00	104.2 PK			1.47 H	327	71.89	32.31
4	*2437.00	94.5 AV			1.47 H	327	62.19	32.31
5	2483.50	69.4 PK	74.0	-4.6	1.42 H	326	36.97	32.43
<b>6</b>	<b>2483.50</b>	<b>53.5 AV</b>	<b>54.0</b>	<b>-0.5</b>	<b>1.42 H</b>	<b>326</b>	<b>21.07</b>	<b>32.43</b>
7	4874.00	52.3 PK	74.0	-21.7	1.10 H	181	10.64	41.66
8	4874.00	42.2 AV	54.0	-11.8	1.10 H	181	0.54	41.66
9	7311.00	51.5 PK	74.0	-22.5	1.26 H	239	5.36	46.14
10	7311.00	41.7 AV	54.0	-12.3	1.26 H	239	-4.44	46.14

**ANTENNA POLARITY & TEST DISTANCE: VERTICAL AT 3 M**

NO.	FREQ. (MHz)	EMISSION LEVEL (dBuV/m)	LIMIT (dBuV/m)	MARGIN (dB)	ANTENNA HEIGHT (m)	TABLE ANGLE (Degree)	RAW VALUE (dBuV)	CORRECTION FACTOR (dB/m)
1	*2437.00	97.7 PK			1.00 V	360	65.39	32.31
2	*2437.00	88.6 AV			1.00 V	360	56.29	32.31
3	4874.00	51.2 PK	74.0	-22.8	1.29 V	175	9.54	41.66
4	4874.00	39.1 AV	54.0	-14.9	1.29 V	175	-2.56	41.66
5	7311.00	55.5 PK	74.0	-18.5	1.29 V	230	9.36	46.14
6	7311.00	43.4 AV	54.0	-10.6	1.29 V	230	-2.74	46.14

**REMARKS:**

1. Emission level (dBuV/m) = Raw Value (dBuV) + Correction Factor (dB/m).
2. Correction Factor (dB/m) = Antenna Factor (dB/m) + Cable Factor (dB).
3. The other emission levels were very low against the limit.
4. Margin value = Emission level – Limit value.
5. " \* ": Fundamental frequency.



A D T

<b>CHANNEL</b>	TX Channel 9	<b>DETECTOR FUNCTION</b>	Peak (PK)
<b>FREQUENCY RANGE</b>	1GHz ~ 25GHz		Average (AV)

**ANTENNA POLARITY & TEST DISTANCE: HORIZONTAL AT 3 M**

NO.	FREQ. (MHz)	EMISSION LEVEL (dBuV/m)	LIMIT (dBuV/m)	MARGIN (dB)	ANTENNA HEIGHT (m)	TABLE ANGLE (Degree)	RAW VALUE (dBuV)	CORRECTION FACTOR (dB/m)
1	*2452.00	100.3 PK			1.44 H	149	67.95	32.35
2	*2452.00	91.9 AV			1.44 H	149	59.55	32.35
3	2483.50	72.2 PK	74.0	-1.8	1.44 H	169	39.77	32.43
4	<b>2483.50</b>	<b>53.5 AV</b>	<b>54.0</b>	<b>-0.5</b>	<b>1.44 H</b>	<b>169</b>	<b>21.07</b>	<b>32.43</b>
5	4904.00	51.6 PK	74.0	-22.4	1.08 H	193	9.89	41.71
6	4904.00	40.2 AV	54.0	-13.8	1.08 H	193	-1.51	41.71
7	7356.00	51.8 PK	74.0	-22.2	1.21 H	235	5.54	46.26
8	7356.00	42.1 AV	54.0	-11.9	1.21 H	235	-4.16	46.26

**ANTENNA POLARITY & TEST DISTANCE: VERTICAL AT 3 M**

NO.	FREQ. (MHz)	EMISSION LEVEL (dBuV/m)	LIMIT (dBuV/m)	MARGIN (dB)	ANTENNA HEIGHT (m)	TABLE ANGLE (Degree)	RAW VALUE (dBuV)	CORRECTION FACTOR (dB/m)
1	*2452.00	92.4 PK			1.00 V	360	60.05	32.35
2	*2452.00	83.5 AV			1.00 V	360	51.15	32.35
3	2483.50	60.8 PK	74.0	-13.2	1.00 V	360	28.37	32.43
4	2483.50	44.2 AV	54.0	-9.8	1.00 V	360	11.77	32.43
5	4904.00	50.2 PK	74.0	-23.8	1.24 V	178	8.49	41.71
6	4904.00	38.2 AV	54.0	-15.8	1.24 V	178	-3.51	41.71
7	7356.00	55.3 PK	74.0	-18.7	1.27 V	218	9.04	46.26
8	7356.00	43.3 AV	54.0	-10.7	1.27 V	218	-2.96	46.26

**REMARKS:**

1. Emission level (dBuV/m) = Raw Value (dBuV) + Correction Factor (dB/m).
2. Correction Factor (dB/m) = Antenna Factor (dB/m) + Cable Factor (dB).
3. The other emission levels were very low against the limit.
4. Margin value = Emission level – Limit value.
5. " \* " : Fundamental frequency.



A D T

### 4.3 6dB BANDWIDTH MEASUREMENT

#### 4.3.1 LIMITS OF 6dB BANDWIDTH MEASUREMENT

The minimum of 6dB Bandwidth Measurement is 0.5 MHz.

#### 4.3.2 TEST INSTRUMENTS

DESCRIPTION & MANUFACTURER	MODEL NO.	SERIAL NO.	CALIBRATED DATE	CALIBRATED UNTIL
R&S Spectrum Analyzer	FSP 40	100060	May 09, 2012	May 08, 2013

**Note:**

1. The calibration interval of the above test instruments is 12 months and the calibrations are traceable to NML/ROC and NIST/USA.
2. Tested date : May 10, 2012

#### 4.3.3 TEST PROCEDURE

1. Set resolution bandwidth (RBW) = approximately 1% of the emission bandwidth
2. Set the video bandwidth (VBW)  $\geq 3 \times$  RBW, Detector = Peak.
3. Trace mode = max hold.
4. Sweep = auto couple.
5. Measure the maximum width of the emission that is constrained by the frequencies associated with the two amplitude points (upper and lower) that are attenuated by 6 dB relative to the maximum level measured in the fundamental emission

#### 4.3.4 DEVIATION FROM TEST STANDARD

No deviation

#### 4.3.5 TEST SETUP

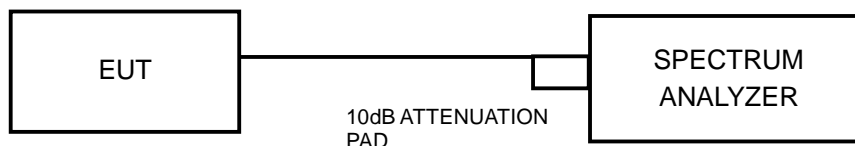

#### 4.3.6 EUT OPERATING CONDITIONS

The software provided by client to enable the EUT under transmission condition continuously at lowest, middle and highest channel frequencies individually.





A D T

#### 4.3.7 TEST RESULTS

##### 802.11b

CHANNEL	FREQUENCY (MHz)	6dB BANDWIDTH (MHz)	MINIMUM LIMIT (MHz)	PASS / FAIL
1	2412	11.71	0.5	PASS
6	2437	11.68	0.5	PASS
11	2462	11.70	0.5	PASS

##### 802.11g

CHANNEL	FREQUENCY (MHz)	6dB BANDWIDTH (MHz)	MINIMUM LIMIT (MHz)	PASS / FAIL
1	2412	16.44	0.5	PASS
6	2437	16.46	0.5	PASS
11	2462	16.46	0.5	PASS

##### 802.11n (20MHz)

CHANNEL	FREQUENCY (MHz)	6dB BANDWIDTH (MHz)	MINIMUM LIMIT (MHz)	PASS / FAIL
1	2412	17.55	0.5	PASS
6	2437	17.54	0.5	PASS
11	2462	17.54	0.5	PASS

##### 802.11n (40MHz)

CHANNEL	FREQUENCY (MHz)	6dB BANDWIDTH (MHz)	MINIMUM LIMIT (MHz)	PASS / FAIL
3	2422	36.28	0.5	PASS
6	2437	36.27	0.5	PASS
9	2452	36.29	0.5	PASS



A D T

#### 4.4 CONDUCTED OUTPUT POWER MEASUREMENT

##### 4.4.1 LIMITS OF MAXIMUM PEAK OUTPUT POWER MEASUREMENT

For systems using digital modulation in the 2400–2483.5 MHz band: 1 Watt (30dBm)

##### 4.4.2 INSTRUMENTS

DESCRIPTION & MANUFACTURER	MODEL NO.	SERIAL NO.	CALIBRATED DATE	CALIBRATED UNTIL
Power Meter	ML2495A	0824006	May 10, 2012	May 09, 2013
Power Sensor	MA2411B	0738172	May 10, 2012	May 09, 2013

**Note:**

1. The calibration interval of the above test instruments is 12 months and the calibrations are traceable to NML/ROC and NIST/USA.
2. Tested date : May 10, 2012

##### 4.4.3 TEST PROCEDURES

A peak power sensor was used on the output port of the EUT. A power meter was used to read the response of the peak power sensor. Record the peak power level.

##### 4.4.4 DEVIATION FROM TEST STANDARD

No deviation

##### 4.4.5 TEST SETUP

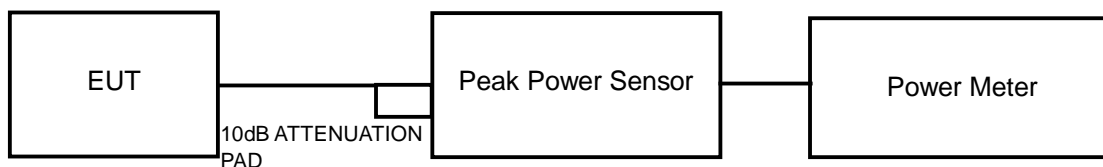

##### 4.4.6 EUT OPERATING CONDITIONS

Same as Item 4.3.6



A D T

#### 4.4.7 TEST RESULTS

##### 802.11b

CHANNEL	FREQUENCY (MHz)	PEAK POWER (mW)	PEAK POWER (dBm)	PEAK POWER LIMIT (dBm)	PASS/FAIL
1	2412	42.658	16.30	30	PASS
6	2437	34.674	15.40	30	PASS
11	2462	36.308	15.60	30	PASS

##### 802.11g

CHANNEL	FREQUENCY (MHz)	PEAK POWER (mW)	PEAK POWER (dBm)	PEAK POWER LIMIT (dBm)	PASS/FAIL
1	2412	301.995	24.80	30	PASS
6	2437	263.027	24.20	30	PASS
11	2462	269.153	24.30	30	PASS

##### 802.11n (20MHz)

CHANNEL	FREQUENCY (MHz)	PEAK POWER (mW)	PEAK POWER (dBm)	PEAK POWER LIMIT (dBm)	PASS/FAIL
1	2412	309.030	24.90	30	PASS
6	2437	269.153	24.30	30	PASS
11	2462	269.153	24.30	30	PASS

##### 802.11n (40MHz)

CHANNEL	FREQUENCY (MHz)	PEAK POWER (mW)	PEAK POWER (dBm)	PEAK POWER LIMIT (dBm)	PASS/FAIL
3	2422	173.780	22.40	30	PASS
6	2437	281.838	24.50	30	PASS
9	2452	134.896	21.30	30	PASS

## 4.5 POWER SPECTRAL DENSITY MEASUREMENT

### 4.5.1 LIMITS OF POWER SPECTRAL DENSITY MEASUREMENT

The Maximum of Power Spectral Density Measurement is 8dBm.

### 4.5.2 TEST INSTRUMENTS

DESCRIPTION & MANUFACTURER	MODEL NO.	SERIAL NO.	CALIBRATED DATE	CALIBRATED UNTIL
R&S Spectrum Analyzer	FSP 40	100060	May 09, 2012	May 08, 2013

**Note:**

1. The calibration interval of the above test instruments is 12 months and the calibrations are traceable to NML/ROC and NIST/USA.
2. Tested date : May 10, 2012

### 4.5.3 TEST PROCEDURE

1. Set the RBW = 100 kHz, VBW =300 kHz, Detector = peak.
2. Sweep time = auto couple, Trace mode = max hold, allow trace to fully stabilize.
3. Use the peak marker function to determine the maximum power level in any 100 kHz band segment within the fundamental EBW.
4. Scale the observed power level to an equivalent value in 3 kHz by adjusting (reducing) the measured power by a bandwidth correction factor (BWCF) where  $BWCF = 10\log(3 \text{ kHz}/100\text{kHz})$

### 4.5.4 DEVIATION FROM TEST STANDARD

No deviation

### 4.5.5 TEST SETUP

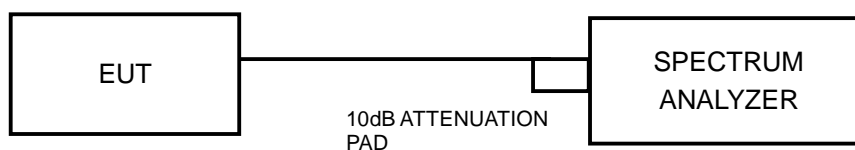

### 4.5.6 EUT OPERATING CONDITION

Same as Item 4.3.6



A D T

#### 4.5.7 TEST RESULTS

##### 802.11b

Channel	FREQ. (MHz)	PSD (dBm/100kHz)	PSD (dBm/3kHz)	Limit (dBm/3kHz)	PASS /FAIL
1	2412	4.28	-10.95	8	PASS
6	2437	3.32	-11.91	8	PASS
11	2462	3.81	-11.42	8	PASS

##### 802.11g

Channel	FREQ. (MHz)	PSD (dBm/100kHz)	PSD (dBm/3kHz)	Limit (dBm/3kHz)	PASS /FAIL
1	2412	1.90	-13.33	8	PASS
6	2437	2.57	-12.66	8	PASS
11	2462	1.86	-13.37	8	PASS

##### 802.11n (20MHz)

Channel	FREQ. (MHz)	PSD (dBm/100kHz)	PSD (dBm/3kHz)	Limit (dBm/3kHz)	PASS /FAIL
1	2412	1.77	-13.46	8	PASS
6	2437	2.55	-12.68	8	PASS
11	2462	-1.69	-16.92	8	PASS

##### 802.11n (40MHz)

Channel	FREQ. (MHz)	PSD (dBm/100kHz)	PSD (dBm/3kHz)	Limit (dBm/3kHz)	PASS /FAIL
3	2422	-3.76	-18.99	8	PASS
6	2437	-2.26	-17.49	8	PASS
9	2452	-5.26	-20.49	8	PASS



A D T

## 4.6 CONDUCTED OUT-BAND EMISSION MEASUREMENT

### 4.6.1 LIMITS OF CONDUCTED OUT-BAND EMISSION MEASUREMENT

Below  $-20\text{dB}$  of the highest emission level of operating band (in 100kHz Resolution Bandwidth).

### 4.6.2 TEST INSTRUMENTS

DESCRIPTION & MANUFACTURER	MODEL NO.	SERIAL NO.	CALIBRATED DATE	CALIBRATED UNTIL
R&S Spectrum Analyzer	FSP 40	100060	May 09, 2012	May 08, 2013

**Note:**

1. The calibration interval of the above test instruments is 12 months and the calibrations are traceable to NML/ROC and NIST/USA.
2. Tested date : May 10, 2012

### 4.6.3 TEST PROCEDURE

#### MEASUREMENT PROCEDURE REF

1. Set the RBW = 100 kHz.
2. Set the VBW  $\geq$  300 kHz.
3. Detector = peak.
4. Sweep time = auto couple.
5. Trace mode = max hold.
6. Allow trace to fully stabilize.
7. Use the peak marker function to determine the maximum power level in any 100 kHz band segment within the fundamental EBW.

## MEASUREMENT PROCEDURE OOB

1. Set RBW = 100 kHz.
2. Set VBW  $\geq$  300 kHz.
3. Set span to encompass the spectrum to be examined
4. Detector = peak.
5. Trace Mode = max hold.
6. Sweep = auto couple.

### 4.6.4 DEVIATION FROM TEST STANDARD

No deviation

### 4.6.5 TEST SETUP

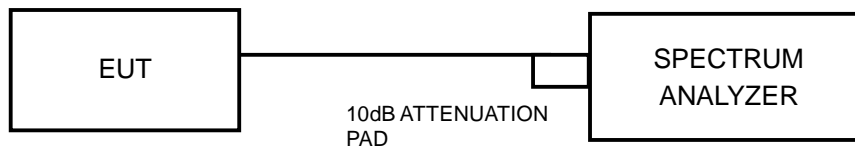

### 4.6.6 EUT OPERATING CONDITION

Same as Item 4.3.6

### 4.6.7 TEST RESULTS

The spectrum plots are attached on the following pages. D1 line indicates the highest level, and D2 line indicates the 20dB offset below D1. It shows compliance with the requirement.



A D T

### 802.11b

#### CH 1

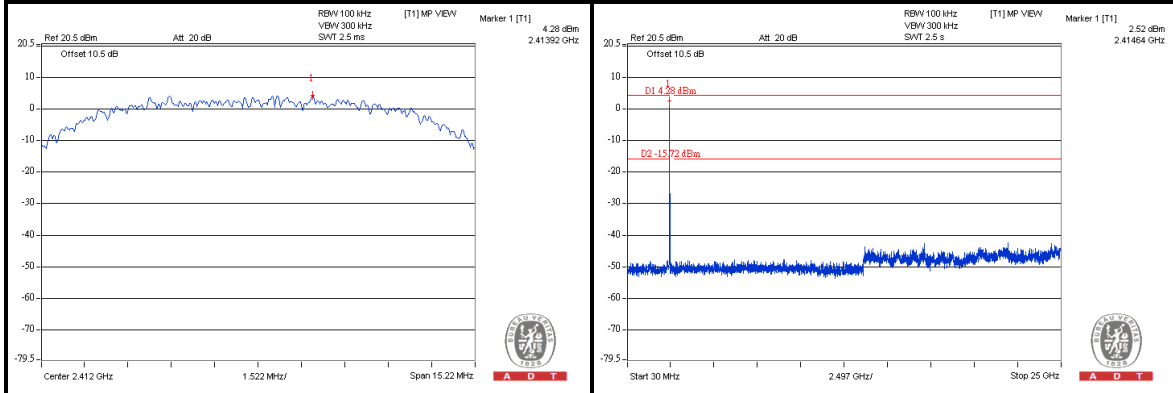

#### CH 6

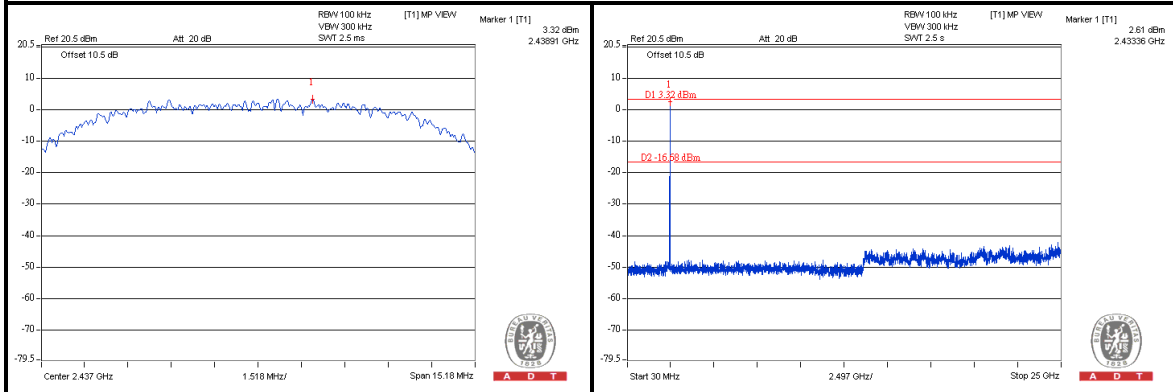

#### CH 11

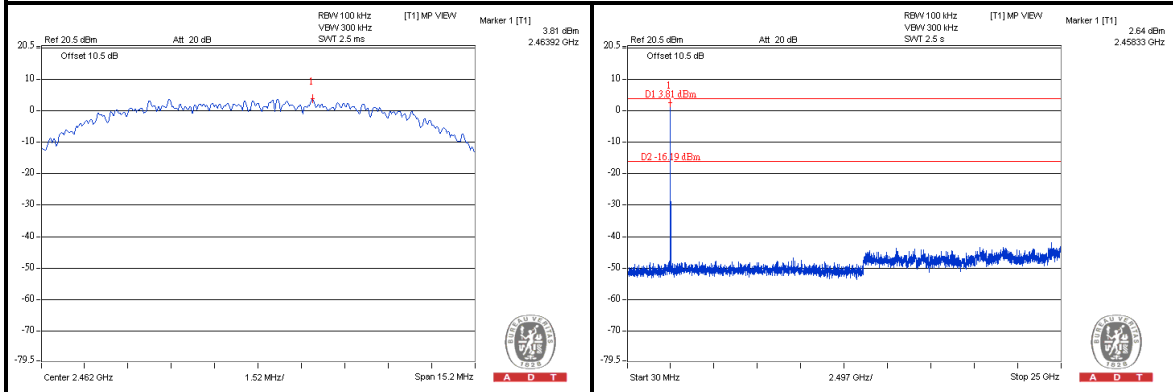





A D T

### 802.11g

#### CH 1

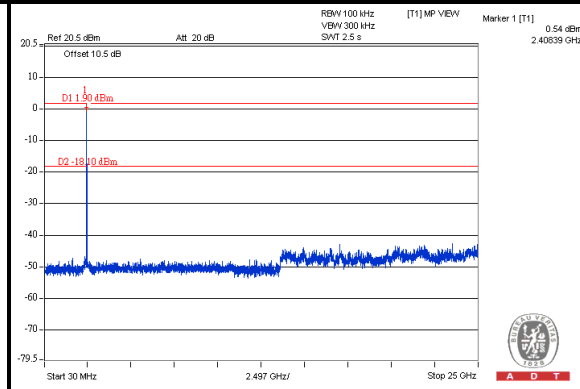
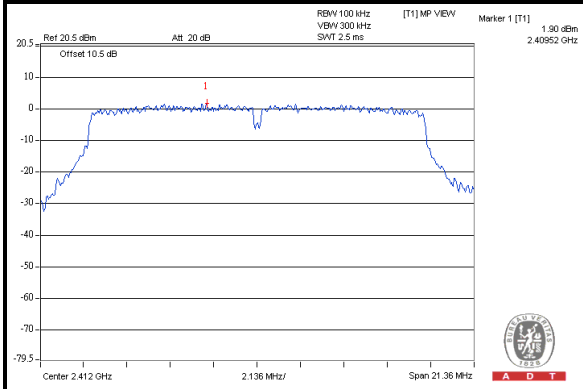

#### CH 6

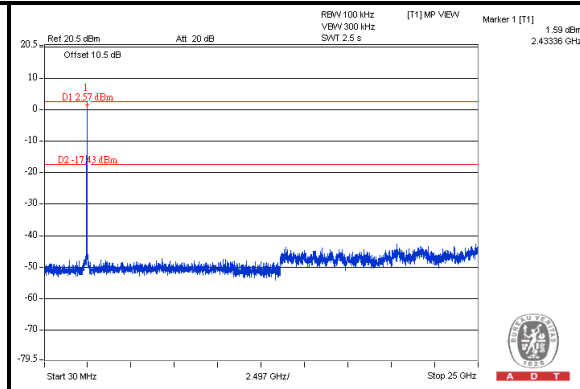
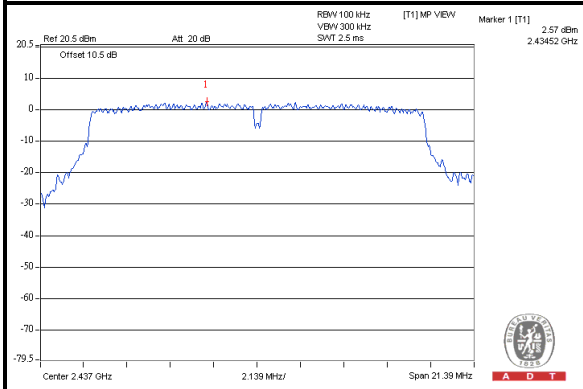

#### CH 11

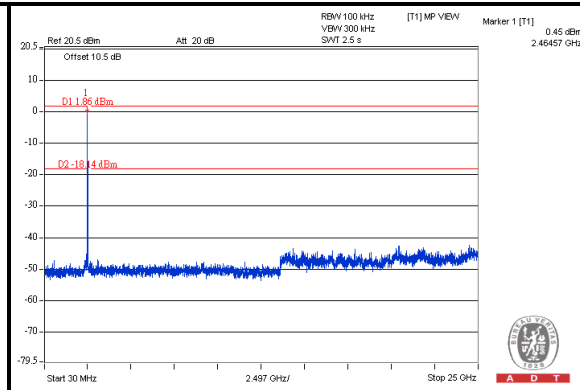
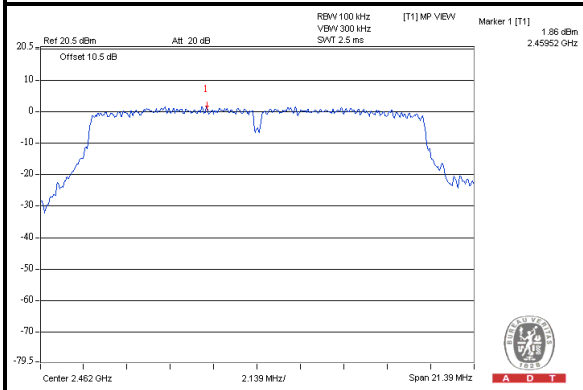



A D T

### 802.11n (20MHz)

#### CH 1

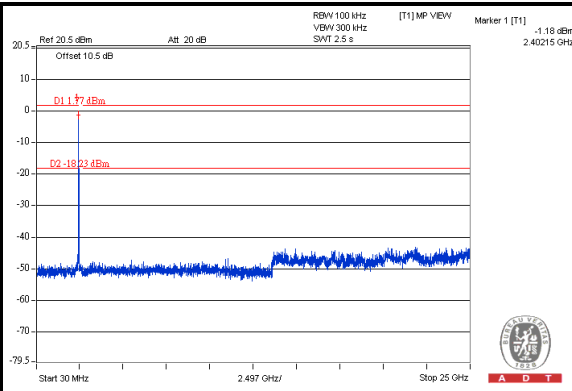
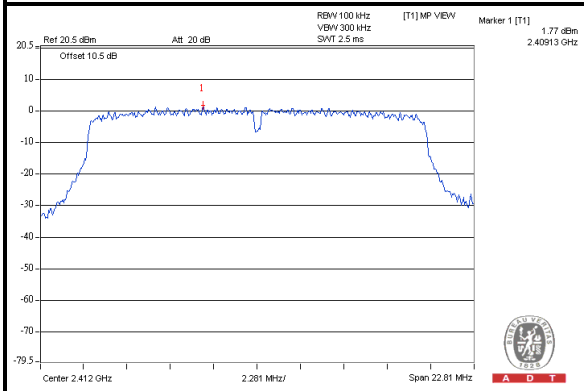

#### CH 6

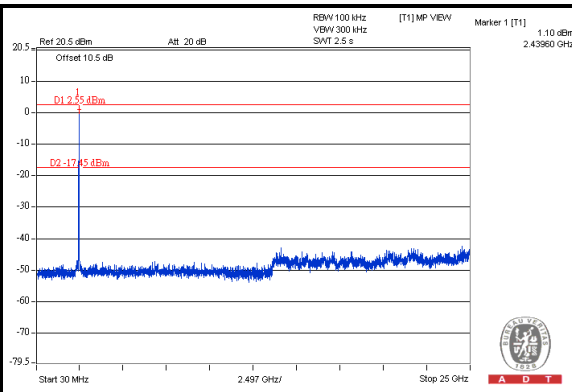
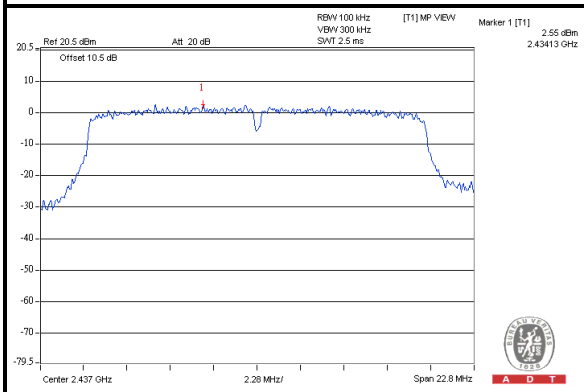

#### CH 11

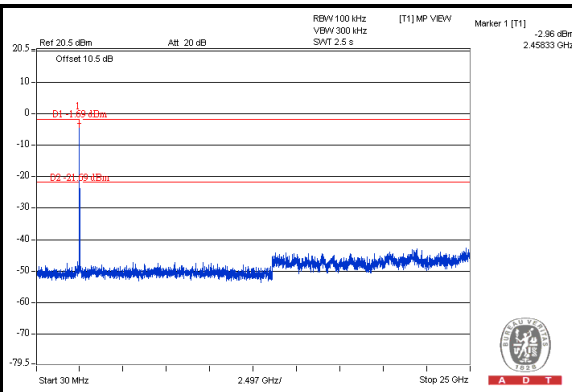
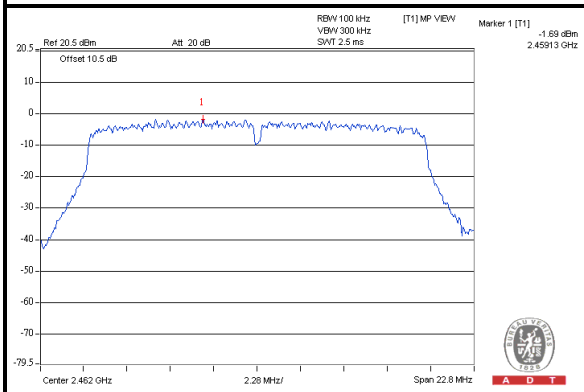



A D T

### 802.11n (40MHz)

#### CH 3

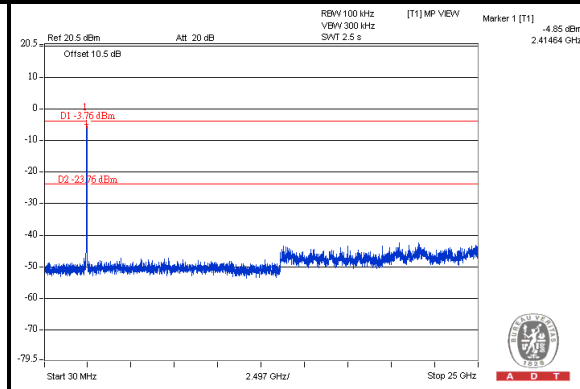
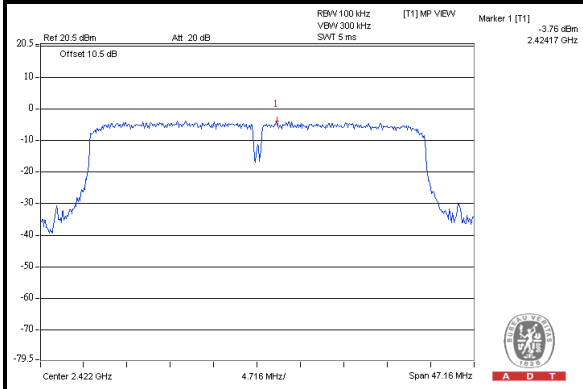

#### CH 6

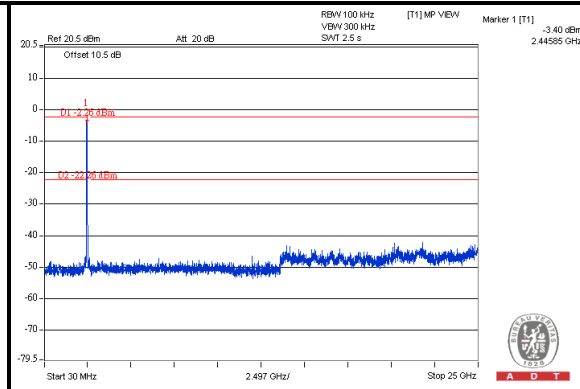
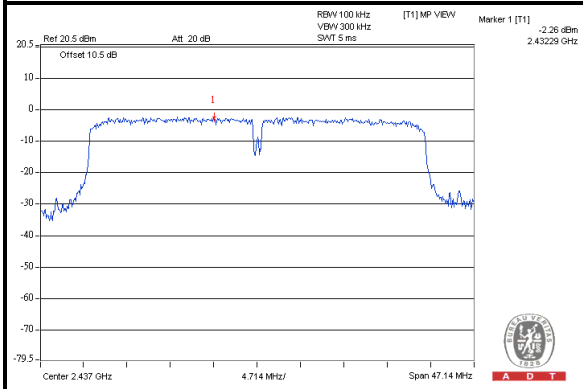

#### CH 9

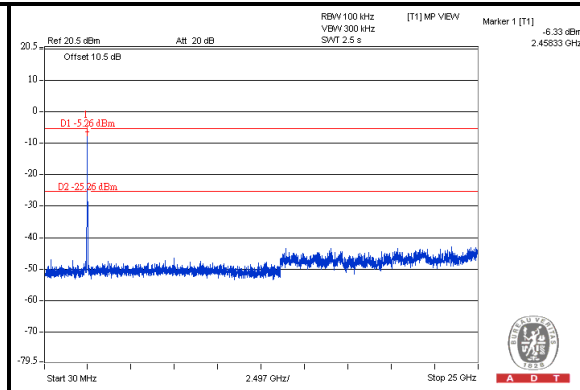
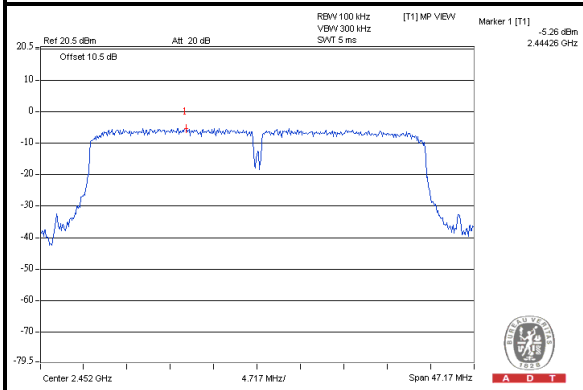



A D T

## 5. PHOTOGRAPHS OF THE TEST CONFIGURATION

Please refer to the attached file (Test Setup Photo).





## 6. INFORMATION ON THE TESTING LABORATORIES

We, Bureau Veritas Consumer Products Services (H.K.) Ltd., Taoyuan Branch, were founded in 1988 to provide our best service in EMC, Radio, Telecom and Safety consultation. Our laboratories are accredited and approved according to ISO/IEC 17025.

If you have any comments, please feel free to contact us at the following:

**Linko EMC/RF Lab:**

Tel: 886-2-26052180

Fax: 886-2-26052943

**Hsin Chu EMC/RF Lab:**

Tel: 886-3-5935343

Fax: 886-3-5935342

**Hwa Ya EMC/RF/Safety/Telecom Lab:**

Tel: 886-3-3183232

Fax: 886-3-3270892

**Email:** [service.adt@tw.bureauveritas.com](mailto:service.adt@tw.bureauveritas.com)

**Web Site:** [www.adt.com.tw](http://www.adt.com.tw)

The address and road map of all our labs can be found in our web site also.



A D T

## **7. APPENDIX A - MODIFICATIONS RECORDERS FOR ENGINEERING CHANGES TO THE EUT BY THE LAB**

No modifications were made to the EUT by the lab during the test.

**--- END ---**