

# ADXV-R-3378P-UB

## Installation and Operating Manual

---

Version 0.1



3116 West Vanowen St.  
Burbank, CA 91505  
Tel: 818-840-8131  
Fax: 818-840-8138

[www.adrftech.com](http://www.adrftech.com)



*Information in this document is subject to change without notice.*

*Advanced RF Technologies, Inc. 1996-2022.  
All rights reserved.*

- Please send comments to:

E-Mail: [info@adrfttech.com](mailto:info@adrfttech.com)

Phone: (818) 840-8131

(800) 313-9345

Fax: (818) 840-8138

- Address:

Advanced RF Technologies, Inc.  
Attention: Technical Publications Department  
3116 Vanowen St.  
Burbank, CA 91505  
USA  
[www.adrfttech.com](http://www.adrfttech.com)

## Revision History

Version	Author	Descriptions	Date
0.1	CK CHO	Initial Release	2022/04/17

## Change List

Version	Change list	Contents

## Table of Contents

1.	Introduction .....	7
1.1	Highlights .....	7
1.2	Parts List.....	8
1.3	Quick View .....	9
1.4	ADXV-R-3378P-UB Parts List.....	11
1.5	Remote Unit (RU) for ADXV-R-3378P-U.....	12
1.6	Quick View .....	12
1.6.1	Port.....	13
1.7	Warnings and Hazards .....	14
2.	Topology .....	17
3.	Cable Connection & Installation .....	18
3.1	FIRE-78-8-UB Wiring Compartment.....	18
3.1.1	AC 100-240V Terminal Block .....	19
3.2	External Alarm .....	19
3.3	Summary Alarm .....	20
3.4	RF .....	21
3.5	Optic .....	22
3.6	Battery .....	23
	This port connects to the ADRF-BBS/BBL-24 (24V battery backup unit) via a dedicated cable provided by the ADRF.....	23
3.7	Grounding .....	24
3.8	ADXV-R-3378P-UB Wiring Compartment .....	25
3.8.1	AC 100-240V Terminal Block .....	26
3.9	External Alarm .....	27
3.10	RF .....	27
3.11	Optic .....	28
3.12	Battery .....	29
	This port connects to the ADRF-BBS/BBL-24 (24V battery backup unit) via a dedicated cable provided by the ADRF.....	29
3.13	Grounding .....	30
4.	RF EXPOSURE WARNING.....	31
5.	Installation .....	32
6.	Specifications .....	33
6.1	Electrical Specifications .....	33
6.2	FIRE-78-8-U_Mechanical Specifications .....	34
6.3	ADXV-R-3378P-U_Mechanical Specifications .....	34
7.2.1	Navigation Tree.....	37

## Figures

Figure 1-1	FIRE-78-8-UB Quick View (front and bottom) .....	9
Figure 2-1	FIRE-78-8-UB DAS topology .....	17
Figure 3-1	AC Power port.....	
Figure 3-2	External Alarm port .....	19
Figure 3-3	RF port .....	21
Figure 3-4	Optic port.....	22
Figure 3-5	Optic Connector Cleaning (left) and Optic Port Cleaning (right) .....	22
Figure 3-6	SC/APC Optic Connector Dust Cap .....	23
Figure 3-7	Protective Earthing Conductor .....	31

# Terms and Abbreviations

The following is a list of abbreviations and terms used throughout this document.

Abbreviation/Term	Definition
<b>AGC</b>	Automatic Gain Control
<b>ALC</b>	Automatic Level Control
<b>AROMS</b>	ADRF' Repeater Operation and Management System
<b>BCU</b>	Band Combiner Unit
<b>BTS</b>	Base Transceiver Station
<b>BDA</b>	Bi-directional Amplifier
<b>CDMA</b>	Code Division Multiple Access
<b>CHC</b>	Channel combiner
<b>CW</b>	Continuous Wave (un-modulated signal)
<b>DAS</b>	Distributed Antenna System
<b>DL</b>	Downlink
<b>Downlink</b>	The path covered from the Base Transceiver Station (BTS) to the subscribers' service area via the repeater
<b>HE</b>	Head End
<b>HPA</b>	High Power Amplifier
<b>HW</b>	Hardware
<b>IF</b>	Intermediate Frequency
<b>LNA</b>	Low Noise Amplifier
<b>LTE</b>	Long Term Evolution
<b>MS</b>	Mobile Station
<b>NMS</b>	Network Management System
<b>ODU</b>	Optical Donor Unit which is located in ADXV-HE.
<b>OEU</b>	Optic Expansion Unit
<b>PLL</b>	Phased Locked Loop
<b>POI</b>	Point Of Interface
<b>PSU</b>	Power Supply Unit
<b>RF</b>	Radio Frequency
<b>RU</b>	Remote Unit which is composed of master RU and multiple slaves RU
<b>RM</b>	Remote Module
<b>SW</b>	Software
<b>UL</b>	Uplink
<b>Uplink</b>	The path covered from the subscribers' service area to the Base Transceiver Station (BTS) via the repeater
<b>VSWR</b>	Voltage Standing Wave Ratio

## 1. INTRODUCTION

ADXV-R-3378P-UB which is Distributed Antenna System for PS-700/800 band has roles which interfaces with Base Station via wireless and optically distributes by connection with multiple [ADXV-R-3378P-UB](#), which is one of the ADRF's DAS product lineups, via optic lines.

### 1.1 Highlights

- Head end supporting 700MHz, 800MHz and Public Safety service band of DAS connected through optic line to ADXV-R-3378P-UB playing a role of Remote unit of DAS for 700/800MHz/Public Safety band
- Fanless
- The RU extension supports up to 22 RUs by connecting 2 ODUs and 2 FIRE-OEUs.
- Supports a total of 2 wide band and up to 32 non-contiguous narrow band channels (700MHz + 800MHz PS)
- Air convection cooling without fans
- Sharp Filter Roll-off performance (Wide: 60dBc @ Filter Bandwidth Edge + 1MHz | Narrow: 55dBc @ Filter Bandwidth Edge + 3 \* Filter BW)
- Supports SNMP v1, v2c, v3 (get, set, & traps)
- Web-based GUI Interface; No 3rd party GUI software required
- Web-GUI connectivity via DHCP in host mode
- External Alarm Function supporting dry contacts, 11 alarming outputs

1.2 Parts List

Table 1-1 Parts List

Label	Quantity	Description
A	1	FIRE-78-8-UB
B	1	Wall Mount Bracket
C	1	Mounting Bracket Template
D	1	AAI Alarm Cable
E	1	AC Power Cable
F	1	Ethernet Cable (Crossover)
G	6	Anchor Bolt
H	1	Documentation CD
I	2	PSR-ANN (Annunciator)

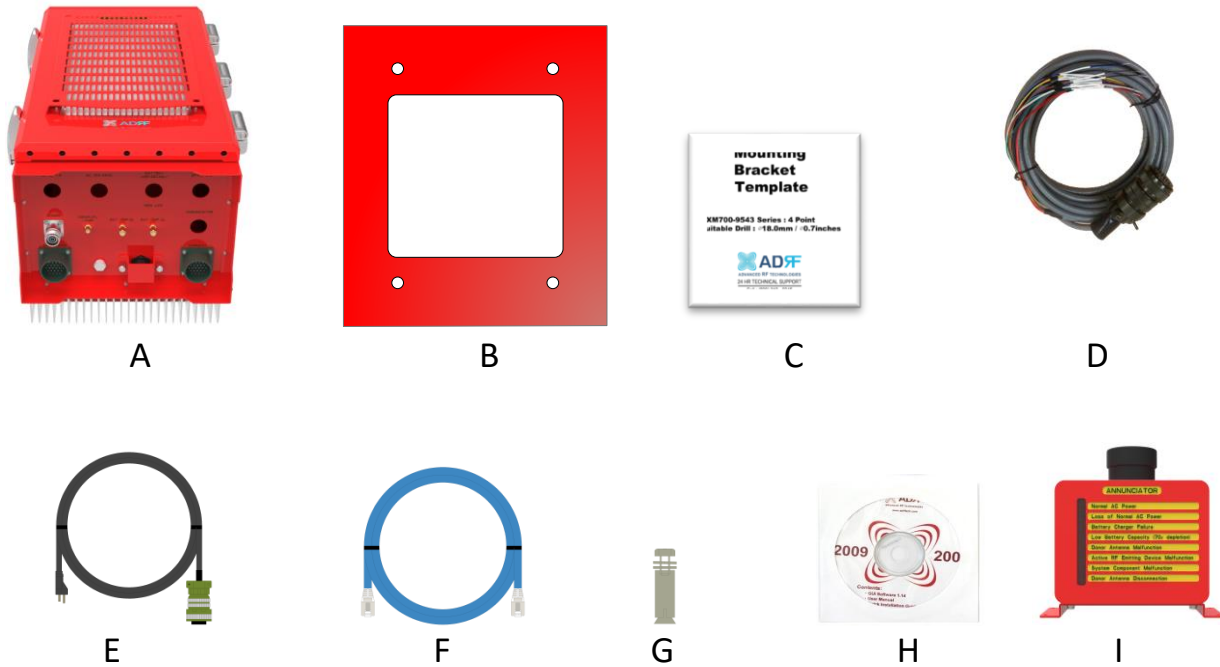

Figure 1-1 FIRE-78-8-UB Parts List



1.3 Quick View

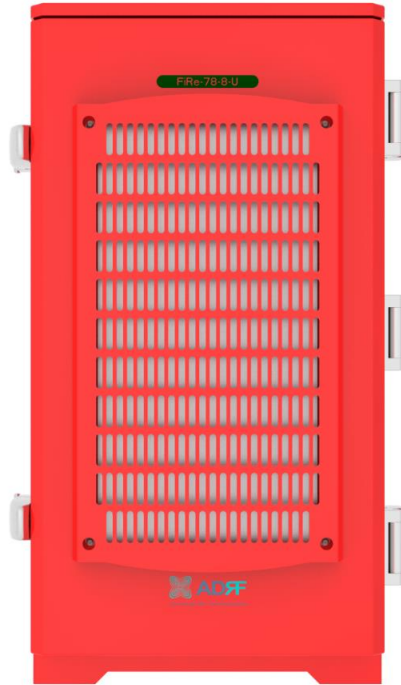

Figure 1-2 FIRE-78-8-UB Quick View (Bottom)

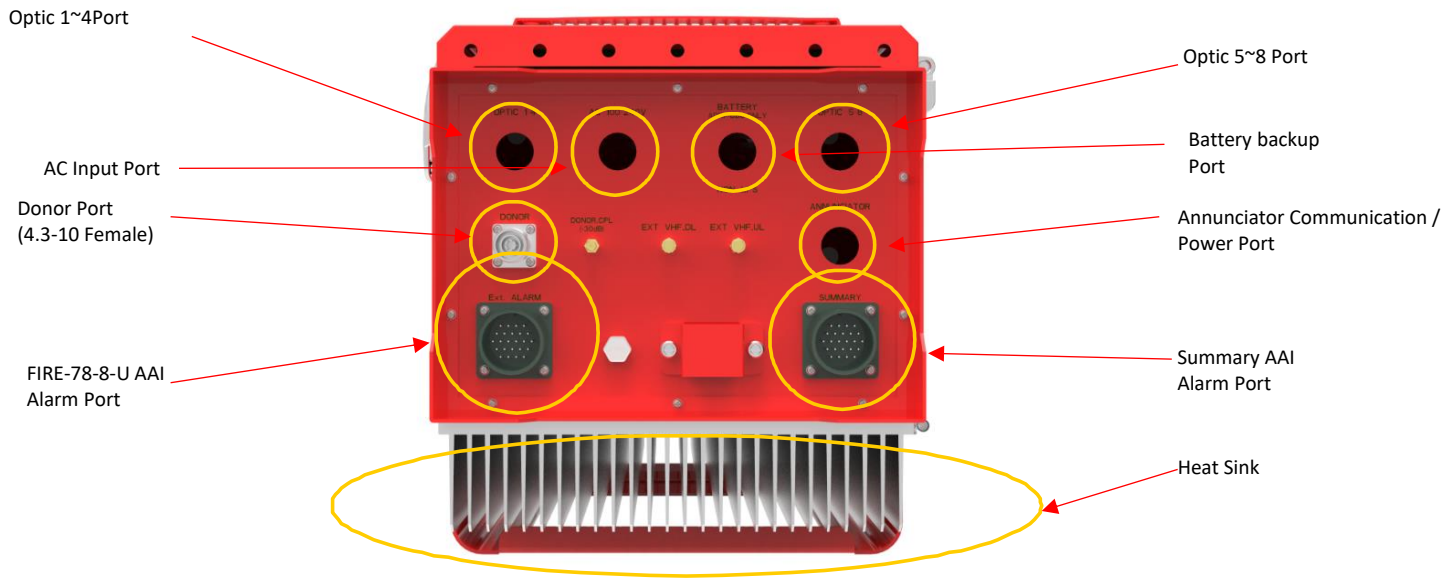

Figure 1-2 FIRE-78-8-UB Quick View (front and bottom)



Figure 1-3 PSR-ANN Annunciator

**1.4 ADXV-R-3378P-UB Parts List**

**Table 1-2 Parts List**

Label	Quantity	Description
A	1	ADXV-R-3378P-UB
B	1	Wall Mount Bracket
C	1	Mounting Bracket Template
D	1	AAI Alarm Cable
E	1	AC Power Cable
F	1	Ethernet Cable (Crossover)
G	6	Anchor Bolt
H	1	Documentation CD
I	1	PSR-ANN (Annunciator)



A

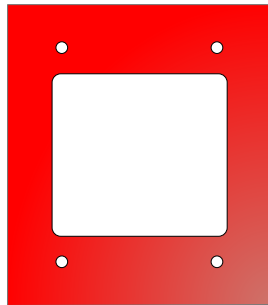

B



C



D

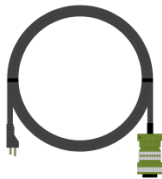

E

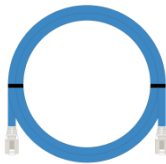

F



G



H



I

**Figure 1-4 ADXV-R-3378P-UB Parts List**

**1.5 Remote Unit (RU) for ADXV-R-3378P-UB**

- ADXV-R-3378P-UB is for PS78
- ADXV-R-3378P-UB\_RU is composed of an ORU, a PSU and an RM(PS78)
- Specifications
  - Size: 9.85 x 15.76 x 6.6 (in)
  - Weight: 28.6lbs
  - Power Input: 110VAC

**1.6 Quick View**



**Figure 1-5 ADXV-R-3378P-UB Front and Bottom View**

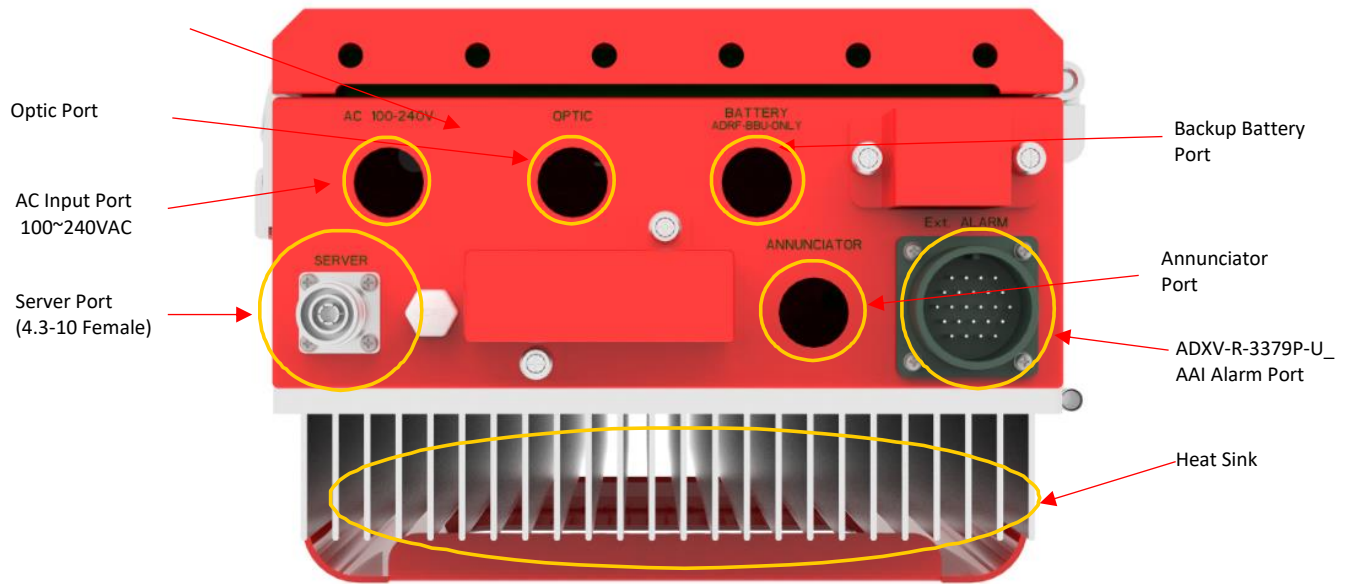

Figure 1-2 ADV-R-3378P-UB Quick View (front and bottom)

1.6.1 Port

- 78PS: SERVER, OPTIC, AC IN, BATTERY, EXTERNAL ALARM

### 1.7 Warnings and Hazards



#### **WARNING! ELECTRIC SHOCK**

Opening the ADXV-R-3378P-UB could result in electric shock and may cause severe injury.

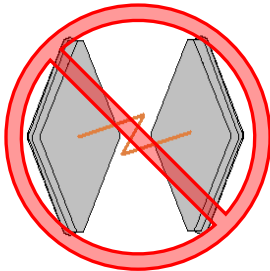

#### **WARNING! DAMAGE TO REPEATER**

Operating the FIRE-78-8-UB with antennas in very close proximity facing each other could lead to severe damage to the repeater.

#### **RF EXPOSURE & ANTENNA PLACEMENT Guidelines**

Actual separation distance is determined upon gain of antenna used.

Please maintain a minimum safe distance of at least 60 cm while operating near the donor and the server antennas. Also, the donor antenna needs to be mounted outdoors on a permanent structure.

\* Maximum antenna gain (700 MHz : 2.6 dBi, 800 MHz : 3.9 dBi) to comply with 5W maximum ERP limit of Part 90.219 (d)(3)

#### **WARRANTY**

Opening or tampering the ADXV-R-3378P-UB will void all warranties.

**Lithium Battery: CAUTION. RISK OF EXPLOSION IF BATTERY IS REPLACED BY INCORRECT TYPE. DISPOSE OF USED BATTERIES ACCORDING TO INSTRUCTIONS.**

**Ethernet Instructions: This equipment is for indoor use only. All cabling should be limited to inside the building. Ethernet connection can only be used for programming/troubleshooting purposes only and is not to be connected during normal operation.**

**Preclude indications that Home/ personal use are prohibited.**

**Use of unauthorized antennas, cables, and/or coupling devices not conforming with ERP/EIRP is prohibited.**

### **FCC Part 15.21**

**Any changes or modifications not expressly approved by the party responsible for compliance could void the user's authority to operate this equipment.**

### **FCC Part 15 Class A**

**NOTE: This equipment has been tested and found to comply with the limits for a Class A digital device, pursuant to part 15 of the FCC Rules. These limits are designed to provide reasonable protection against harmful interference when the equipment is operated in a commercial environment. This equipment generates, uses, and can radiate radio frequency energy and, if not installed and used in accordance with the instruction manual, may cause harmful interference to radio communications. Operation of this equipment in a residential area is likely to cause harmful interference in which case the user will be required to correct the interference at their own expense.**

### **FCC Part 90 Class B**

**WARNING. THIS is NOT a CONSUMER device. It is designed for installation by FCC LICENSEES and QUALIFIED INSTALLERS. You MUST have an FCC LICENSE or express consent of an FCC Licensee to operate this device. You MUST register Class B signal boosters (as defined in 47 CFR 90.219) online at [www.fcc.gov/signal-boosters/registration](http://www.fcc.gov/signal-boosters/registration). Unauthorized use may result in significant forfeiture penalties, including penalties in excess of \$100,000 for each continuing violation.**

## Regulatory Warning Statement

### FCC RF Radiation Exposure Statement:

This equipment complies with FCC RF radiation exposure limits set forth for an uncontrolled environment. This equipment should be installed and operated with a minimum distance of 60 cm between the radiator and your body. This transmitter must not be co-located or operating in conjunction with any other antenna or transmitter.

## RSS-GEN (6.8 Transmit antenna)

Under Industry Canada regulations, this radio transmitter may only operate using an antenna of a type and maximum gain approved for the transmitter by Industry Canada. To reduce potential radio interference to other users, the antenna type and its gain should be so chosen that the equivalent isotropically radiated power (e.i.r.p.) is not more than that necessary for successful communication. (DL: Omni-Directional Indoor Serving Antenna, Max. peak gain: 700 MHz - 2.6 dBi, 800 MHz-3.9 dBi)

Confonctionner avec une antenne d'un type et d'un gain maximal approuvé pour l'émetteur par Industrie Canada. Dans le but de réduire les risques de brouillage radioélectrique à l'intention des autres utilisateurs, il faut choisir le type d'antenne et son gain de sorte que la puissance isotroperayonnée équivalente (p.i.r.e.) ne dépasse pas l'intensité nécessaire à l'établissement d'une communication satisfaisante.

(DL: Omni-Directional Indoor Serving Antenna, Max. peak gain: 700 MHz - 2.6 dBi, 800 MHz-3.9 dBi)

## RF Radiation Exposure

This equipment complies with RF radiation exposure limits set forth for an uncontrolled environment. This equipment should be installed and operated with a minimum distance of 80 cm between the radiator and your body. This transmitter must not be co-located or operating in conjunction with any other antenna or transmitter. RF exposure will be addressed at time of installation and the use of higher gain antennas require larger separation distances.

L'antenne (ou les antennes) doit être installée de façon à maintenir à tout instant une distance minimum de au moins 80cm entre la source de radiation (l'antenne) et toute personne physique. Cet appareil ne doit pas être installé ou utilisé en conjonction avec une autre antenne ou émetteur.



## 2. TOPOLOGY

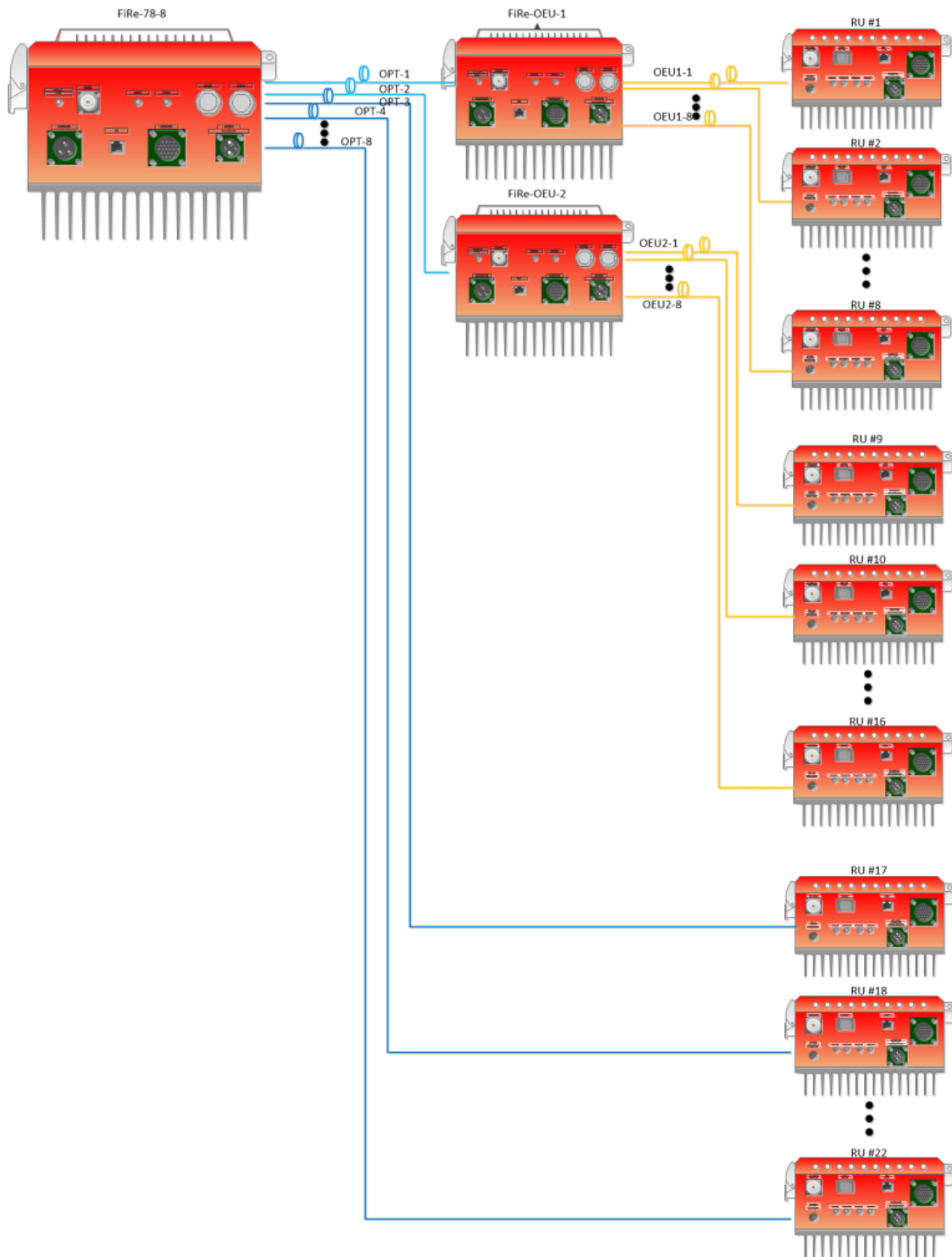

Figure 2-1 DAS topology

### 3. CABLE CONNECTION & INSTALLATION

#### 3.1 FIRE-78-8-UB Wiring Compartment

The bottom of the FIRE-78-8-UB is a wiring compartment with pre-cut holes. These holes are designed to be used in conjunction with conduit hubs to prevent water ingress. A total of 5 pre-cut holes are available to use for the various cables that will be needed for the proper operation of the FIRE-78-8-UB.

To maintain UL 2524 Listed status, unused ports must be properly weather proofed.

**Table 3-1 Pre-cut hole size and labels**

Silkscreen Label	Location	Diameter
AC 100-240V	BOTTOM	22.2mm (7/8")
ANNUNCIATOR	BOTTOM	22.2mm (7/8")
BATTERY ADRF-BBU ONLY NON LPS	BOTTOM	22.2mm (7/8")
Optic 1~4	BOTTOM	22.2mm (7/8")
Optic 5~8	BOTTOM	22.2mm (7/8")



**Figure 3-1 Wiring Compartment Cutout Holes**

### 3.1.1 AC 100-240V Terminal Block

The AC 100-240V Terminal Block is located on the left side of the wiring compartment. One side of the terminal block will be pre-wired and connected to the PSU and the chassis ground. The open terminals must be connected to an AC power source between 100-240V AC and secured in an electrical breaker box on its own circuit. The terminal block can support up to a cable gauge of 12AWG.

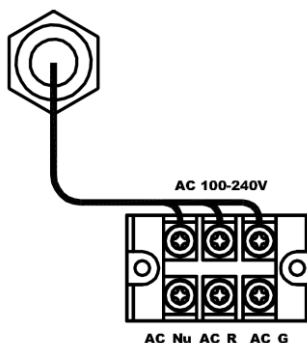

Figure 3-2 AC 100-240V Terminal Block

Table 3-2 Terminal Block Definition

Silkscreen Label	Line Type	Max Supported AWG
AC_NU	Neutral	12AWG
AC_R	Line or Hot	12AWG
AC_G	Ground	12AWG

### 3.2 External Alarm

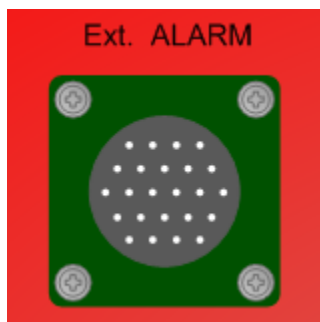

Figure 3-3 External Alarm port

This port should be connected to ADRF External Alarm Box for dry-contact alarming of FIRE-78-8-UB

Table 3-3 External Alarm Port Pin Description

	Color	Pin Description (24 pins)	ADRF External Alarm Box Pin Description
1	Black	Donor antenna malfunction_P	1-POS
2	Black	Donor antenna malfunction_N	1-NEG
3	Brown	Active RF device malfunction_P	2-POS
4	Brown	Active RF device malfunction_N	2-NEG
5	Red	Low battery capacity (70%)_P	3-POS
6	Red	Low battery capacity (70%)_N	3-NEG
7	Orange	System component malfunction_P	4-POS
8	Orange	System component malfunction_N	4-NEG
9	Yellow	Normal AC Power_P	5-POS
10	Yellow	Normal AC Power_N	5-NEG
11	Green	Loss of normal AC Power_P	6-POS
12	Green	Loss of normal AC Power_N	6-NEG
13	Blue	Battery charger failure_P	7-POS
14	Blue	Battery charger failure_N	7-NEG
15	Purple	Donor Antenna Disconnect_P	8-POS
16	Purple	Donor Antenna Disconnect_N	8-NEG
17	Grey	ANN Disconnection_P	9-POS
18	Grey	ANN Disconnection_N	9-NEG
19	White	Summary Alarm_P	10-POS
20	White	Summary Alarm_N	10-NEG
21	Pink	Oscillation Alarm_P	11-POS
22	Pink	Oscillation Alarm_N	11-NEG
23	Light Blue	AUX_IN_P	12-POS
24	Light Blue	AUX_IN_N	12-NEG

### 3.3 Summary Alarm

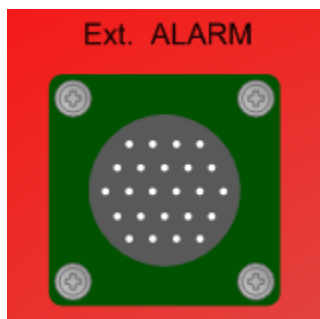

Figure 3-4 Summary Alarm port

This port should be connected to ADRF External Alarm Box for dry-contact alarming of All RUs

Table 3-4 Summary Alarm Port Pin Description

	Color	Pin Description (24 pins)	ADRF External Alarm Box Pin Description
--	-------	---------------------------	--

1	Black	SUMRU_Donor antenna malfunction_P	1-POS
2	Black	SUMRU_Donor antenna malfunction_N	1-NEG
3	Brown	SUMRU_Active RF device malfunction_P	2-POS
4	Brown	SUMRU_Active RF device malfunction_N	2-NEG
5	Red	SUMRU_Low battery capacity (70%)_P	3-POS
6	Red	SUMRU_Low battery capacity (70%)_N	3-NEG
7	Orange	SUMRU_System component malfunction_P	4-POS
8	Orange	SUMRU_System component malfunction_N	4-NEG
9	Yellow	SUMRU_Normal AC Power_P	5-POS
10	Yellow	SUMRU_Normal AC Power_N	5-NEG
11	Green	SUMRU_Loss of normal AC Power_P	6-POS
12	Green	SUMRU_Loss of normal AC Power_N	6-NEG
13	Blue	SUMRU_Battery charger failure_P	7-POS
14	Blue	SUMRU_Battery charger failure_N	7-NEG
15	Purple	SUMRU_Donor Antenna Disconnect_P	8-POS
16	Purple	SUMRU_Donor Antenna Disconnect_N	8-NEG
17	Grey	SUMRU_ANN Disconnection_P	9-POS
18	Grey	SUMRU_ANN Disconnection_N	9-NEG
19	White	SUMRU_Summary Alarm_P	10-POS
20	White	SUMRU_Summary Alarm_N	10-NEG
21	Pink	SUMRU_Oscillation Alarm_P	11-POS
22	Pink	SUMRU_Oscillation Alarm_N	11-NEG
23	Light Blue	NC	NC
24	Light Blue	NC	NC

### 3.4 RF



**Figure 3-5 RF port**

The RF connections are made via three “4.3-10” female connectors. The RF connector labeled “DONOR” must be connected to each antenna pointing towards the base station.

The RF connections must be made through cables with characteristic impedance of 50 ohms.

### 3.5 Optic

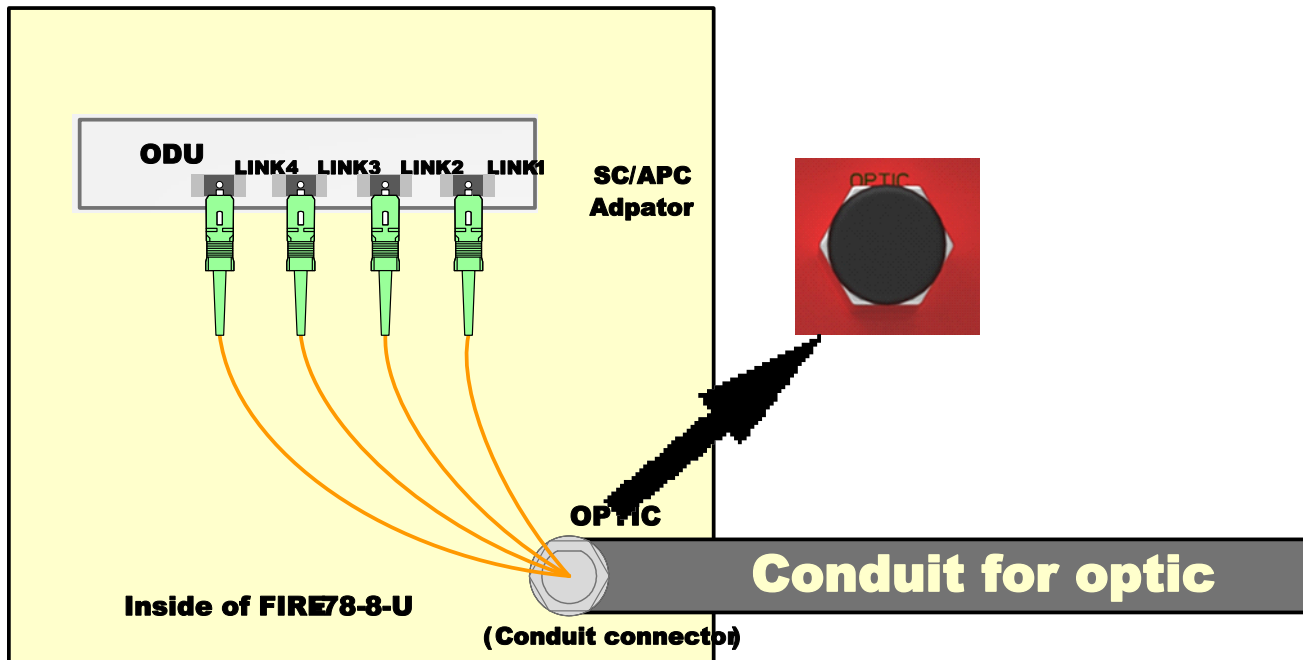

Figure 3-6 Optic port

ODU located inside of equipment has 8 optic ports (SC/APC type) for link to ADXV-R-3378P-UB.

You must verify to keep optic contact be clean and optic line's curvature be not allowed in order to be free from optic loss when you install optic line and conduit.

- We recommend cleaning optic connector using a dry optical cleaning swab or tissue in a dry environment as needed. We recommend cleaning the optic connectors only if the expected optic loss is higher than the loss reported in the Web-GUI by 1.5dB<sub>o</sub>. (Figure 3-7)
- When optic connector are not in use, the port should be covered with a protective dust cap. (Figure 3-8)
- 

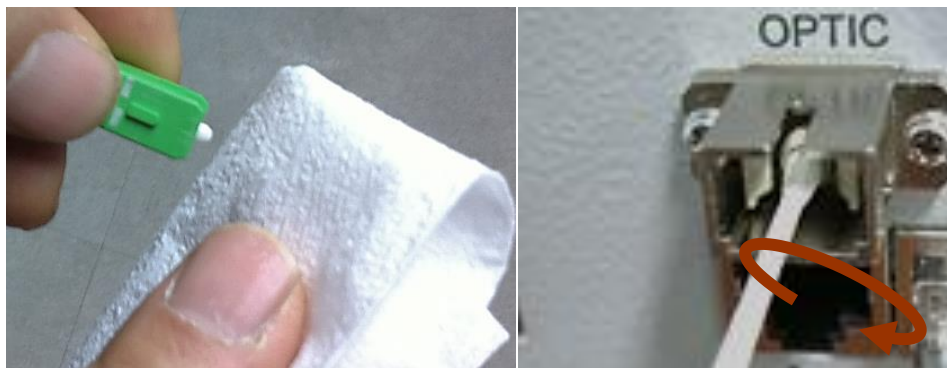

Figure 3-7 Optic Connector Cleaning (left) and Optic Port Cleaning (right)

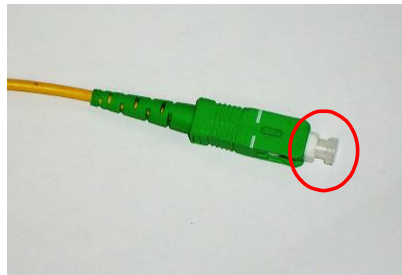

Figure 3-8 SC/APC Optical Connector Dust Cap

### 3.6 Battery

This port connects to the ADRF-BBS/BBL-24 (24V battery backup unit) via a dedicated cable provided by the ADRF.

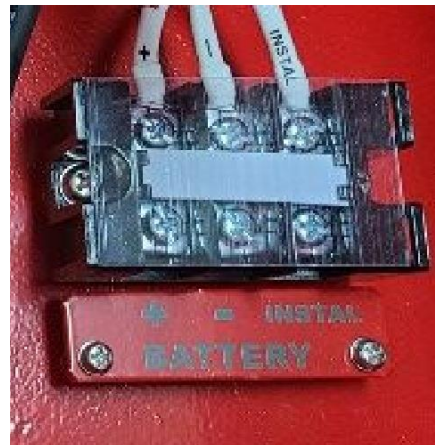

Figure 3-9 Battery Backup Port

If an ADRF-BBS/BBL-24 is connected to the repeater, the battery switch on the PSU must be switched to the ON position. This will enable the repeater to charge the ADRF-BBS/BBL-24 battery backup unit when AC power is present.



Figure 3-10 Battery Switch

The FIRE-78-8-UB can be connected to an ADRF-BBS/BBL-24 to provide power during a power failure. If an ADRF-BBS/BBL-24 is utilized, connect it to the FIRE-78-8-UB via the external battery port.

***(WARNING: The circuit breaker switch on the ADRF-BBS/BBL-24 must be set to OFF before connecting it to the FIRE-78-8-UB to prevent damage to the repeater or the ADRF-BBS/BBL-24 and personal injury.)***

Note: Please contact ADRF Technical Support for assistance if you are unfamiliar with the installation procedure of the battery box.

### 3.7 Grounding

A ground cable is included in the box. The grounding terminals are located at lower right-hand side of the equipment. The grounding cable should be properly connected before powering on the equipment.





**Figure 3-11 Protective Earthing Conductor**

**3.8 ADXV-R-3378P-UB Wiring Compartment**

The bottom of the ADXV-R-3378P-UB is a wiring compartment with pre-cut holes. These holes are designed to be used in conjunction with conduit hubs to prevent water ingress. A total of 4 pre-cut holes are available to use for the various cables that will be needed for the proper operation of the ADXV-R-3378P-UB.

To maintain UL 2524 Listed status, unused ports must be properly weather proofed.

**Table 3-5 Pre-cut hole size and labels**

Silkscreen Label	Location	Diameter
AC 100-240V	BOTTOM	22.2mm (7/8")
ANNUNCIATOR	BOTTOM	22.2mm (7/8")
BATTERY ADRF-BBU ONLY NON LPS	BOTTOM	22.2mm (7/8")
Optic	BOTTOM	22.2mm (7/8")

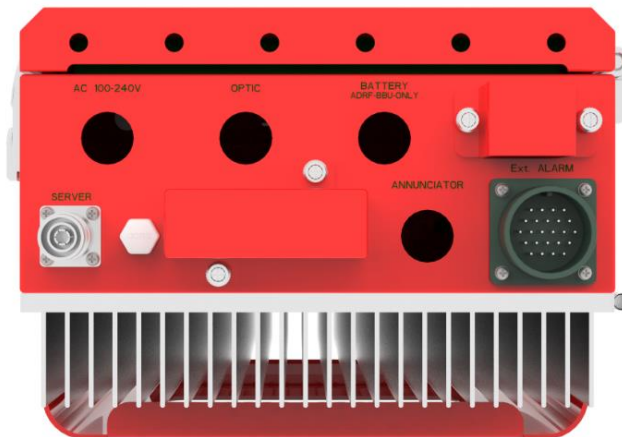

Figure 3-12 Wiring Compartment Cutout Holes

### 3.8.1 AC 100-240V Terminal Block

The AC 100-240V Terminal Block is located on the left side of the wiring compartment. One side of the terminal block will be pre-wired and connected to the PSU and the chassis ground. The open terminals must be connected to an AC power source between 100-240V AC and secured in an electrical breaker box on its own circuit. The terminal block can support up to a cable gauge of 12AWG.

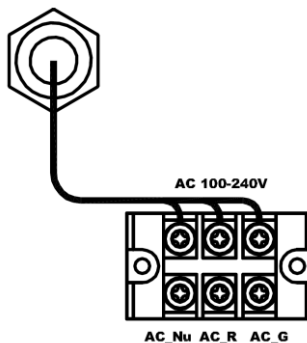
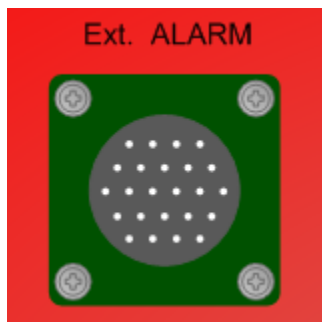

Figure 3-13 AC 100-240V Terminal Block

Table 3-6 Terminal Block Definition

Silkscreen Label	Line Type	Max Supported AWG
AC_NU	Neutral	12AWG
AC_R	Line or Hot	12AWG
AC_G	Ground	12AWG

### 3.9 External Alarm



**Figure 3-14 External Alarm port**

This port should be connected to ADRF External Alarm Box for dry-contact alarming of ADXV-R-3378P-UB

**Table 3-7 External Alarm Port Pin Description**

	Color	Pin Description (24 pins)	ADRF External Alarm Box Pin Description
1	Black	Donor antenna malfunction_P	1-POS
2	Black	Donor antenna malfunction_N	1-NEG
3	Brown	Active RF device malfunction_P	2-POS
4	Brown	Active RF device malfunction_N	2-NEG
5	Red	Low battery capacity (70%)_P	3-POS
6	Red	Low battery capacity (70%)_N	3-NEG
7	Orange	System component malfunction_P	4-POS
8	Orange	System component malfunction_N	4-NEG
9	Yellow	Normal AC Power_P	5-POS
10	Yellow	Normal AC Power_N	5-NEG
11	Green	Loss of normal AC Power_P	6-POS
12	Green	Loss of normal AC Power_N	6-NEG
13	Blue	Battery charger failure_P	7-POS
14	Blue	Battery charger failure_N	7-NEG
15	Purple	Donor Antenna Disconnect_P	8-POS
16	Purple	Donor Antenna Disconnect_N	8-NEG
17	Grey	ANN Disconnection_P	9-POS
18	Grey	ANN Disconnection_N	9-NEG
19	White	Summary Alarm_P	10-POS
20	White	Summary Alarm_N	10-NEG
21	Pink	Oscillation Alarm_P	11-POS
22	Pink	Oscillation Alarm_N	11-NEG
23	Light Blue	AUX_IN_P	12-POS
24	Light Blue	AUX_IN_N	12-NEG

### 3.10 RF

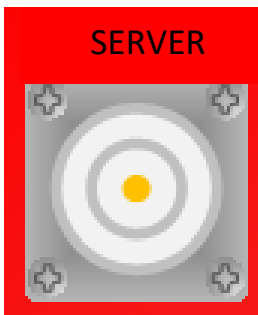

Figure 3-15 RF port

The RF connections are made via three “4.3-10” female connectors. The RF connector labeled “SERVER” must be connected to each antenna pointing towards the base station.

The RF connections must be made through cables with characteristic impedance of 50 ohms.

### 3.11 Optic

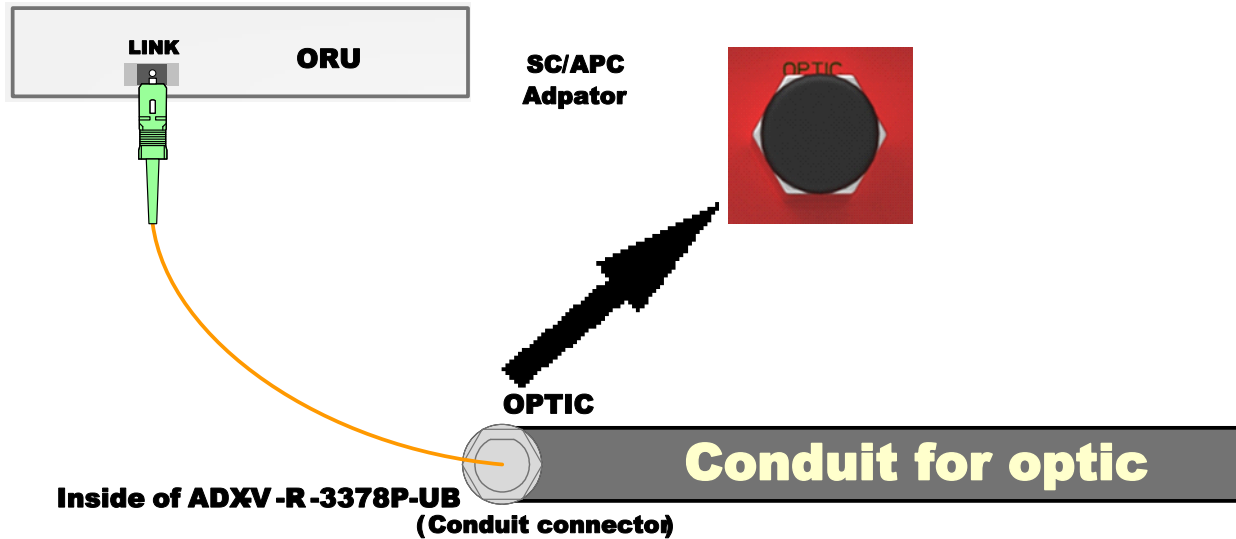
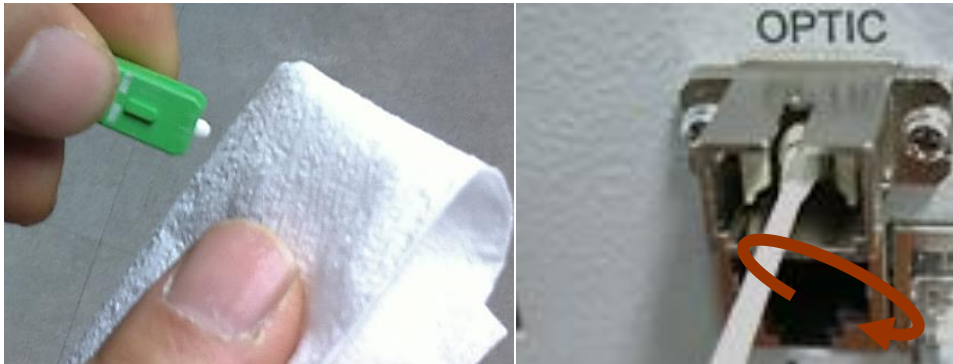

Figure 3-16 Optic port

ORU located inside of equipment has 1 optic ports (SC/APC type) for link to ADXV-R-3378P-UB.

You must verify to keep optic contact be clean and optic line’s curvature be not allowed in order to be free from optic loss when you install optic line and conduit.

- We recommend cleaning optic connector using a dry optical cleaning swab or tissue in a dry environment as needed. We recommend cleaning the optic connectors only if the expected optic loss is higher than the loss reported in the Web-GUI by 1.5dB<sub>o</sub>. (Figure 3-7)
- When optic connector are not in use, the port should be covered with a protective dust cap. (Figure 3-8)
- 



**Figure 3-17 Optic Connector Cleaning (left) and Optic Port Cleaning (right)**

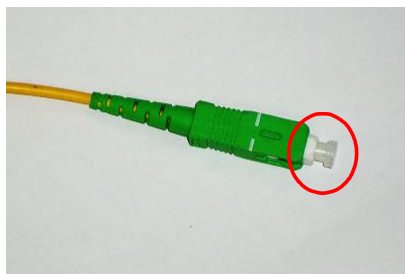

**Figure 3-18 SC/APC Optic Connector Dust Cap**

### 3.12 Battery

This port connects to the ADRF-BBS/BBL-24 (24V battery backup unit) via a dedicated cable provided by the ADRF.



**Figure 3-19 Battery Backup Port**

If an ADRF-BBS/BBL-24 is connected to the repeater, the battery switch on the PSU must be switched to the ON position. This will enable the repeater to charge the ADRF-BBS/BBL-24 battery backup unit when AC power is present.



**Figure 3-20 Battery Switch**

The ADXV-R-3378P-UB can be connected to an ADRF-BBS/BBL-24 to provide power during a power failure. If an ADRF-BBS/BBL-24 is utilized, connect it to the ADXV-R-3378P-UB via the external battery port.

***(WARNING: The circuit breaker switch on the ADRF-BBS/BBL-24 must be set to OFF before connecting it to the FIRE-78-8-UB to prevent damage to the repeater or the ADRF-BBS/BBL-24 and personal injury.)***

Note: Please contact ADRF Technical Support for assistance if you are unfamiliar with the installation procedure of the battery box.

### 3.13 Grounding

A ground cable is included in the box. The grounding terminals are located at lower right-hand side of the equipment. The grounding cable should be properly connected before powering on the equipment.



**Figure 3-21 Protective Earthing Conductor**

Ground terminals located on the side consisted of a 16mm<sup>2</sup>(6AWG) and should be permanently connected to earth(Protective earthing conductor).

#### 4. INSTALLATION



**WARNING.** This is **NOT** a **CONSUMER** device. It is designed for installation by **FCC LICENSEES** and **QUALIFIED INSTALLERS**. You **MUST** have an **FCC LICENSE** or express consent of an FCC Licensee to operate this device. Unauthorized use may result in significant forfeiture penalties, including penalties in excess of \$100,000 for each continuing violation.

1. To mount on a wall. Using appropriate screws and anchors, attach the BDA to the wall at the four mounting holes
  2. Ensure that the isolation between the donor antenna and the service antenna is at least 15 dB greater than the BDA gain.
  3. Connect the cable from the donor antenna to the BDA connector labeled “DONOR” and the cable from the service antennas to the BDA connector labeled “SERVER”.
  4. Connect the AC power cord to the BDA and turn on the switch at the left-hand of PSU.
  5. Installation of the equipment is now complete. Adjust the gain controls to suit the specific signal environment through GUI on your PC.
- To prevent feedback, the donor and server antennas must be separated by an appropriate distance to provide sufficient isolation. Isolation is attained by separating antennas a sufficient distance so that the output of one antenna does not reach the input of the other. This distance is dependent on the gain of the repeater.
  - Prior to equipment use the service must be registered with the FCC. This can be done through the FCC’s website at <https://signalboosters.fcc.gov/signal-boosters>)



## 5. SPECIFICATIONS

### 5.1 Electrical Specifications

Parameters		Specifications		Remarks
		DL	UL	
Frequency Range (MHz)	FirstNet +PS 700	769 - 775MHz(For FCC) (768-769MHz Guard band) 768 - 775 MHz (For ISED)	799 - 805 MHz(For FCC) (798- 799MHz Guard band) 798- 805 MHz (For ISED)	
	PS 800	851-861	806-816	
Composite Output Power of FIRE-78-8-UB	FirstNet +PS 700	-24dBm	30dBm	
	PS 800	-24dBm	30dBm	
	FirstNet +PS 700+ PS 800	-24dBm	30dBm	
Composite Output Power of FIRE-78-8-UB+ADXV-R-78PS	FirstNet +PS 700	33dBm	30dBm	
	PS 800	33dBm	30dBm	
	PS 700 + PS 800	33dBm	30dBm	
System total Gain (dB) [FIRE-78-8-UB+ADXV-R-3378P-U]		95	85	
System total Input power [FIRE-78-8-UB+ADXV-R-3378P-U]		-62dBm	-55dBm	
Filter selection	Wideband	2 (non-contiguous)		
	Narrowband (N Mode)	Up to 16 (non-contiguous) @ PS 700 Up to 16 (non-contiguous) @ PS 800		
	Narrowband (S1 Mode)	Up to 12 (non-contiguous) @ PS 700 Up to 20 (non-contiguous) @ PS 800		
	Narrowband (S7 Mode)	Up to 32 (non-contiguous) @ PS 700		
	Narrowband (S8 Mode)	Up to 32 (non-contiguous) @ PS 800		
Filter Bandwidth	Narrow (kHz)	75 ~325 kHz (12.5 x n , n= 6~26)		
Filter Roll-off	Narrow	≥ 55dBc @ Filter Bandwidth Edge + 3 x Filter		
Spurious		FCC Rule Compliant		
Passband Ripple		±2dB		
ALC Dynamic Range		≥ 60dB		DL Path Only
Gain Dynamic Range		≥ 40dB		
Channel Setting Resolution		0.025kHz		
System Group Delay	Narrow Band	≤ 46us @ 12.5 KHz BW, ≤ 28us @ 25 KHz BW, ≤ 18us @ 75 KHz BW, ≤ 15us @ 100 KHz BW, ≤ 13us @ 150 KHz BW, ≤ 12us @ 200 KHz BW		Except of optic cable delay, Except of ADXV-R-3378P-U
Power Supply		100 - 240 VAC, 60Hz (Free Voltage)		With battery backup,
Power Consumption		TBD		
Max RF Input Power without overdrive		-20dBm		
UL Noise Figure @ Max. Gain		5.0dB Center Frequency		[FIRE-78-8-UB+ADXV-R-3378P-U]
No damage Max Input Power		+10dBm		DL Path Only
Enclosure Cooling		Natural Convection		
Impedance		50 Ω		
VSWR		<1.5 : 1		DL/UL Input
Dry Contacts		NFPA 72 2016 Code/UL 2524 Compliant		

Remote Alarming / Network Management	Dry Contacts, Web-GUI, SNMP, SNMP-Traps (External Wireless Modem Required)	
Annunciator Support	up to 2 PSR-ANN-L annunciators	
Relative Humidity	5% - 90%	
Operating Temperature	-22°F to +131°F (-30°C to +55°C)	

### 5.2 FIRE-78-8-UB\_Mechanical Specifications

Dimension (W x D x H)	11.0 x 12.2 x 21.3 in (280 x 310.5 x 540mm)	w/out mounting bracket
Weight	72.7 lbs (35.0 kg)	
RF Connector	4.3-10 (Female)	
Weather Resistance	IP66 / NEMA 4	
Optic Terminal Tray (internal)	2	8 optic cables per optic tray in the enclosure

### 5.3 ADXV-R-3378P-UB\_Mechanical Specifications

Dimension (W x D x H)	9.85 x 6.62 x 15.76 in (250 x 168 x 400mm)	w/out mounting bracket
Weight	32.0 lbs (14.5 kg)	
RF Connector	4.3-10 (Female)	
Weather Resistance	IP66 / NEMA 4	
Optic Terminal Tray (internal)	1	

## 6. FIRE-78-8-UB & ADXV-R-3378P-UB Web-GUI Setup

The Web-GUI allows the user to communicate with the repeater either locally or remotely. To connect to the repeater locally, you will need a laptop with an Ethernet port and an RJ-45 crossover cable. To connect to the repeater remotely, you will need to have an active internet connection via an external modem or LAN.

### 6.1 Repeater/PC Connection Using Web-GUI

Verify that your Local Area Network Connection is set to obtain an IP address automatically under the Internet Protocol (TCP/IP) properties.

If you are connecting to the unit remotely (use of a modem), then skip step above.

Connect the RJ-45 crossover cable between the laptop's Ethernet port and the repeater's Ethernet port.

Launch an Internet Browser.

Type the following IP address into the address bar of the Internet Browser: <http://192.168.63.1>

If you are connecting to the unit remotely, then type the IP address of the modem to connect to the unit

The following login screen will appear:

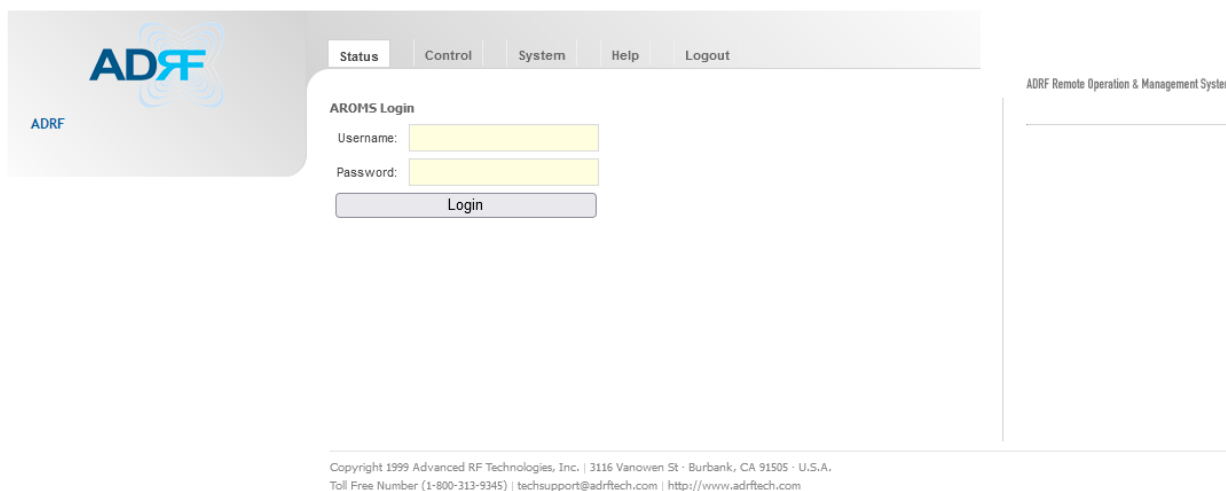

ADRF

ADRF Remote Operation & Management System

AROMS Login

Username:

Password:

Login

Copyright 1999 Advanced RF Technologies, Inc. | 3116 Vanowen St - Burbank, CA 91505 - U.S.A.  
Toll Free Number (1-800-313-9345) | techsupport@adrfttech.com | http://www.adrfttech.com

- **Figure 5-1 Login Page**

If you are not the Administrator, please type in your assigned username & password which you should have received from the Administrator.

The default username and password for the General User is adrf & adrf, respectively.

The default Administrator login is admin & admin, respectively.

## 6.2 Status Tab

**FIRe-78-8**  
Site ID : ADRF

Lock System

[Expand All](#) | [Collapse All](#)

[-] FIRe-78-8 ●

[+] FIRe-ODU-8 ●

Status
Control
Install
Tools
System
Help
Logout

**Summary**

	NMS	ODU	OEU	ORU	RM
Connected	1	1	0	1	1
Soft Fail	1	0	0	1	1
Hard Fail	0	0	0	0	0
Link Fail	0	0	0	0	0
Not Commissioned	-	1	0	-	1
Commissioned	-	0	0	-	0

Uptime : 0 days 03:10:18

PS700		PS800	
Power & Gain			
		Downlink	Uplink
Input [dBm]		--	--
OutBand [dBm]		--	--
Gain [dB]	User Set	-7.0	21.0
	Actual	-7.0	21.0
Output [dBm]		--	--

		Downlink			Uplink		
		Input (dBm)	Center Frequency (MHz)	BW (KHz)	Input (dBm)	Center Frequency (MHz)	BW (KHz)
Broad	Channel 1	--	--	--	--	--	--
	Channel 2	--	--	--	--	--	--
	Channel 3	--	--	--	--	--	--
	Channel 4	--	--	--	--	--	--
Narrow	Channel 5	--	--	--	--	--	--
	Channel 6	--	--	--	--	--	--
	Channel 7	--	--	--	--	--	--
	Channel 8	--	--	--	--	--	--
	Channel 9	--	--	--	--	--	--
	Channel 10	--	--	--	--	--	--
	Channel 11	--	--	--	--	--	--
	Channel 12	--	--	--	--	--	--
	Channel 13	--	--	--	--	--	--
	Channel 14	--	--	--	--	--	--
	Channel 15	--	--	--	--	--	--
	Channel 16	--	--	--	--	--	--

**Alarms**

System	PS700	PS800	Power
Over Temperature		Door Open	
DSP Fail		System Halt	

■ Normal
 ■ Soft Fail
 ■ Hard Fail
 ■ Inactive

**AAI**

Name	HE	RU
[1] Donor Antenna Disconnection		
[2] Summary Alarm		
[3] Oscillation Alarm		
[4] Annunciator Disconnection		
[1] Normal AC Power		
[2] Loss of Normal AC Power		
[3] Battery Charger Failure		
[4] Low Battery Capacity (70% depletion)		
[5] Donor Antenna Malfunction		
[6] Active RF Emitting Device Malfunction		
[7] System Component Malfunction		

AAI Alarm In

■ Active
 ■ Inactive

ADRF Remote Operation & Management System

**Information**

Serial Number	P-FIRE788U220003
Latitude	
Longitude	
Firmware	80800601700013
Web GUI	1.0.03

**Location**

**Description**

**Technical Support**

Phone: 1-800-313-9345  
E-mail: [techsupport@adrftech.com](mailto:techsupport@adrftech.com)

**Installer Contact Info**

Company:  
Installer:  
Phone:  
E-mail:

Copyright 1999 Advanced RF Technologies, Inc. | 3116 Vanowen St - Burbank, CA 91505 - U.S.A.  
Toll Free Number (1-800-313-9345) | [techsupport@adrftech.com](mailto:techsupport@adrftech.com) | <http://www.adrftech.com>

• **Figure 5-2 Status Tab**









Advanced RF Technologies, Inc.

36

### 6.2.1 Navigation Tree

The navigation tree located on the left hand side of the Web-GUI allows the user to switch between the various modules that are connected to the system.

**Table 5-1 Navigation tree**

Parameters	Description
<a href="#">Expand All</a>	Expands the entire navigation tree
<a href="#">Collapse All</a>	Collapses the entire navigation tree
	The module has the expandable subordinate modules
	The branch is currently expanded
	The module has soft fail alarm
	The module has hard fail alarm
	The module has no alarms (normal)
 [0]FIRe-78-8   [1]FIRe-ODU-8 	The selected module will have bright gray color

### 6.2.2 System Summary

**Table 5-2 System Summary Description**

Parameters	Description
Connected	Display the number of modules physically connected to ADXV DAS
Soft Fail	Display the number of soft fail present on each module
Hard Fail	Display the number of hard fail present on each module
Link Fail	Display the number of link fail present on each module
Not Commissioned	Display the number of non-commissioned or commission failed module
Commissioned	Display the number of successfully commissioned module

### 6.2.3 Band Info

The Band Info section displays frequency information along with the corresponding bandwidths that have been set from the Install tab. Input levels for each channel are also displayed in this section.

		Downlink			Uplink		
		Input (dBm)	Center Frequency (MHz)	BW (KHz)	Input (dBm)	Center Frequency (MHz)	BW (KHz)
Broad	Channel 1	--	--	--	--	--	--
	Channel 2	--	--	--	--	--	--
Narrow	Channel 1	--	--	--	--	--	--
	Channel 2	--	--	--	--	--	--
	Channel 3	--	--	--	--	--	--
	Channel 4	--	--	--	--	--	--
	Channel 5	--	--	--	--	--	--
	Channel 6	--	--	--	--	--	--
	Channel 7	--	--	--	--	--	--
	Channel 8	--	--	--	--	--	--
	Channel 9	--	--	--	--	--	--
	Channel 10	--	--	--	--	--	--
	Channel 11	--	--	--	--	--	--
	Channel 12	--	--	--	--	--	--
	Channel 13	--	--	--	--	--	--
	Channel 14	--	--	--	--	--	--
Channel 15	--	--	--	--	--	--	
Channel 16	--	--	--	--	--	--	

• **Figure 5-3 Band Info Display**

#### 6.2.4 Power & Gain

This section displays the Input, Gain, and Output for both downlink and uplink.

Power & Gain		Downlink	Uplink
Input [dBm]		--	--
OutBand [dBm]		--	--
Gain [dB]	User Set	50.0	50.0
	Actual	50.0	50.0
Output [dBm]		--	--

• **Figure 5-4 Power & Gain Display**

**Input [dBm]** – Displays the in-band Downlink/Uplink signal level. The system will display “--.” when the input level is < -90 dBm.

**Outband [dBm]** – Displays the out-band composite power.

**Gain [dB]**

User Set: Displays the amount of gain that the user set.

Actual: Displays the actual amount of gain that is currently in use.

**Output [dB]** – Displays the Downlink/Uplink composite output power levels. The system will display “--.”, when the output level is < +5 dBm.

### 6.2.5 Alarms

This section displays the alarm status for System alarms, RF Alarms, and Power alarms. If an alarm is present in the system, then the color of the alarm tab will change according to the type of failure.

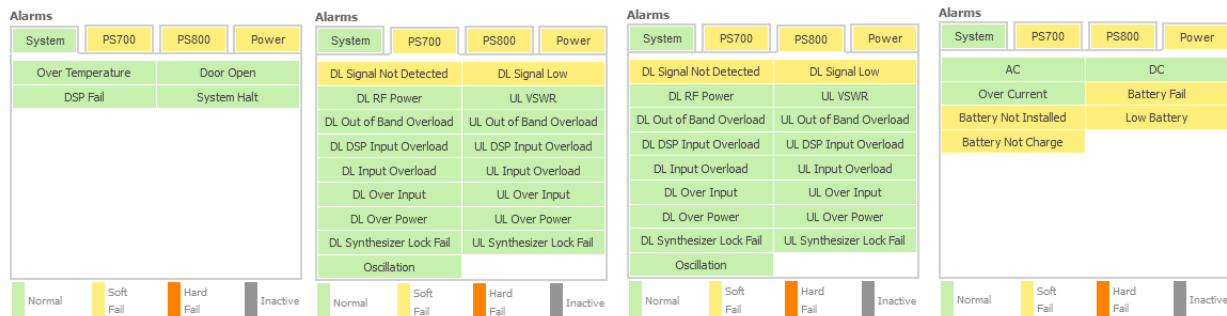

• **Figure 5-5 Alarm Display**

### 6.2.6 Repeater Info / Repeater Location / Technical Support / Installer Contact Info

#### ADRF Remote Operation & Management System

##### Information

Serial Number	P-FIRE788U220003
Latitude	
Longitude	
Firmware	80800601700013
Web GUI	1.0.03

##### Location

##### Description

##### Technical Support

Phone: 1-800-313-9345

E-mail: [techsupport@adrftech.com](mailto:techsupport@adrftech.com)

##### Installer Contact Info

Company:

Installer:

Phone:

E-mail:

• **Figure 5-6 Repeater Info / Repeater Location / Technical Support / Installer Contact Info**

**Repeater Info:** Displays the serial number, latitude, longitude, firmware version, and Web-GUI version

**Repeater Location:** Displays the address where the repeater is installed

**Technical Support:** Displays ADRF’s Technical Support contact information

**Installer Contact Info:** Displays the installer’s name, phone, and e-mail address

**Note: Once successfully logged in, the repeater model name and the site/cascade ID will be displayed on the top of all the windows (except for the Main Window).**

### 6.3 Control Tab

**General Settings**

ALC On

PS 700 DL On     PS 800 DL On

PS 700+800 UL HPA On

**System**

PS700

**Manual Gain Control**

DL Gain [dB] -7.0

UL Gain [dB] 21.0

DL ALC Level [dBm] -24.0

UL ALC Level [dBm] 30.0

DL ALC Offset Level [dBm] 3.0

UL ALC Offset Level [dBm] 3.0

DL /UL Gain Balance ON Off

PS800

**Alarm Settings**

DL Signal Low Level [dBm] -85.0

DL Signal Not Detect Level [dBm] -90.0

DL RF Power Level [dBm] 6.0

DL Over Power Level [dBm] -24.0

UL Over Power Level [dBm] 30.0

**Battery Alarm Settings**

Battery Check Check All

Battery Not Charge Check On

**AAI Control**

Normal Operation  Closed  
 Open

Donor Antenna Disconnection Check Time 3min

**ANN Setup**

ANN #1 Enable

ANN #2 Disable

**AAI Test**

AAI Test On

	HE	RU		HE	RU
<b>Additional Info</b>			<b>System Monitoring</b>		
[1] Donor Antenna Disconnection	Set	Normal	[1] Normal AC Power	Set	Set
[2] Summary Alarm	Set	Set	[2] Loss of Normal AC Power	Normal	Normal
[3] Oscillation Alarm	Normal	Normal	[3] Battery Charger Failure	Set	Set
[4] Annunciator Disconnection	Set	Set	[4] Low Battery Capacity (70% depletion)	Set	Set
			[5] Donor Antenna Malfunction	Normal	Normal
			[6] Active RF Emitting Device Malfunction	Normal	Set
			[7] System Component Malfunction	Normal	Normal

• **Figure 5-7 Control page**



### 6.3.1 General Setting

The General Setting section allows the user to enable/disable amplifiers and the ALC routine.

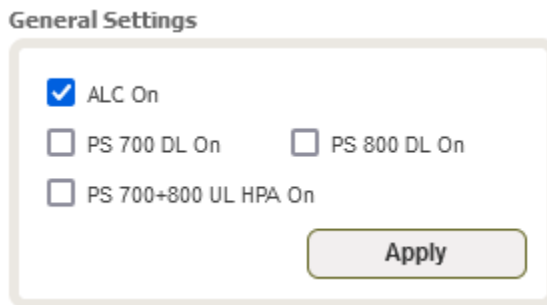

• **Figure 5-8 General Setting**

**ALC ON:** Enables or disables Automatic Level Control (ALC)

**PSR 700 DL HPA On:** Enables or disables the Downlink High Power Amplifier (HPA) for 700MHz PS

**PSR 800 DL HPA On:** Enables or disables the Downlink High Power Amplifier (HPA) for 800MHz PS

**PSR 700+800 UL HPA On:** Enables or disables the Uplink High Power Amplifier (HPA) for 700+800MHz PS

To enable/disable any of the settings, click on the checkbox and click the Apply button.

### 6.3.2 System

Under the System section, the user is able to perform soft reboot on the repeater and also can restore factory default settings.



• **Figure 5-9 System**

**Reboot:** Performs a soft reboot of the repeater

**Factory Set:** Restores all settings to factory defaults

### 6.3.3 Manual Gain Control

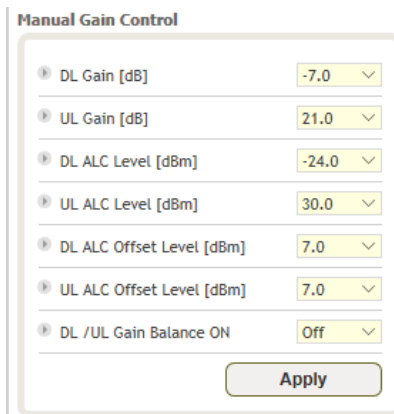

• **Figure 5-10 Manual Gain Control Setting**

**DL/UL Gain:** Gain levels of the repeater can be specified here

**DL/UL ALC Level:** Prevents the output power from exceeding the specified value

**DL/UL Output ALC Offset:** If any ALC attenuation has been applied, the system will release this attenuation when the signal level drops by the specified level

**DL /UL Gain Balance ON:** Allows the user to enable or disable the gain balance. When gain balance is enabled, the delta value between the downlink and uplink gains remain constant

### 6.3.4 Alarm Settings

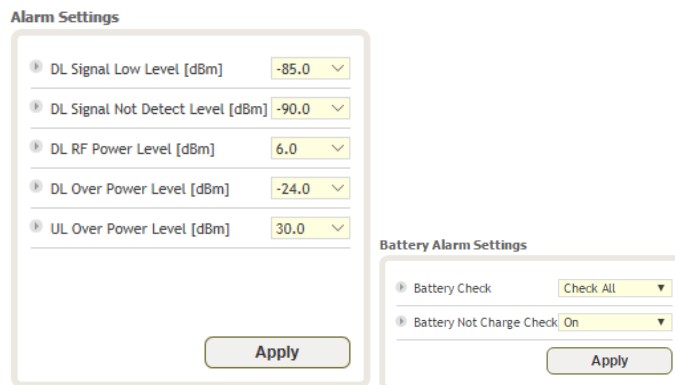

The image shows two configuration panels. The 'Alarm Settings' panel on the left contains five dropdown menus: 'DL Signal Low Level [dBm]' set to -85.0, 'DL Signal Not Detect Level [dBm]' set to -90.0, 'DL RF Power Level [dBm]' set to 6.0, 'DL Over Power Level [dBm]' set to -24.0, and 'UL Over Power Level [dBm]' set to 30.0. Below these is an 'Apply' button. The 'Battery Alarm Settings' panel on the right contains two dropdown menus: 'Battery Check' set to 'Check All' and 'Battery Not Charge Check' set to 'On'. Below these is an 'Apply' button.

• **Figure 5-11 Alarm Settings**

**DL Signal Low Level:** Allows the user to specify how low the signal can be before triggering a “Downlink Signal Low” soft-fail alarm

**DL Signal Not Detected Level:** Allows the user to specify how low the signal can be before triggering a “Downlink Signal Not Detected” soft-fail alarm

**DL RF Power Level:** Allows the user to set a maximum deviation value for the downlink RF power before triggering a “DL RF Power Level” soft-fail alarm

For example, if the input signal is -50 dBm and the gain is set to 60 dB, the expected output power should be 10 dBm. If the Downlink RF Power alarm value is set to 6dB, then a soft-fail alarm will trigger if the output power falls below 4 dBm

**DL Over Power Level:** DL Over Power Alarm will trigger when the DL output level exceeds this level

**UL Over Power Level:** UL Over Power Alarm will trigger when the UL output level exceeds this level

**Battery Check:**

- Check All – All battery related alarms are checked which include Battery Fail, Battery Not Installed, Low Battery, and Battery Not Charge
- Except Install – Only Battery Fail, Low Battery, and Battery Not Charge alarms are checked
- Check Off – Does not perform any battery check

**Battery Not Charge Check:**

- On – Checks for the Battery Not Charge alarm
- Off – Disables the check for the Battery Not Charge alarm

## 6.4 Install Tab

### 6.4.1 Install

**Technology**

N - PS700 (16ch) + PS8

Freq Spacing Restriction

**Band Selection**

		PS700				PS800			
		Channel Center Frequency (MHz)	Bandwidth (kHz)	Downlink Gain (dB)	DSP Output Level (dBm)	Set	Downlink Freq (MHz)		
							Start	End	
Broad	PS70 <input type="text"/>	--	OFF <input type="text"/>	0.0 <input type="text"/>	--	<input type="button" value="Apply"/>	--	--	
	PS70 <input type="text"/>	--	OFF <input type="text"/>	0.0 <input type="text"/>	--	<input type="button" value="Apply"/>	--	--	
Narrow	Ch. 1	--	OFF <input type="text"/>	0.0 <input type="text"/>	--	<input type="button" value="Apply"/>	--	--	
	Ch. 2	--	OFF <input type="text"/>	0.0 <input type="text"/>	--	<input type="button" value="Apply"/>	--	--	
	Ch. 3	--	OFF <input type="text"/>	0.0 <input type="text"/>	--	<input type="button" value="Apply"/>	--	--	
	Ch. 4	--	OFF <input type="text"/>	0.0 <input type="text"/>	--	<input type="button" value="Apply"/>	--	--	
	Ch. 5	--	OFF <input type="text"/>	0.0 <input type="text"/>	--	<input type="button" value="Apply"/>	--	--	
	Ch. 6	--	OFF <input type="text"/>	0.0 <input type="text"/>	--	<input type="button" value="Apply"/>	--	--	
	Ch. 7	--	OFF <input type="text"/>	0.0 <input type="text"/>	--	<input type="button" value="Apply"/>	--	--	
	Ch. 8	--	OFF <input type="text"/>	0.0 <input type="text"/>	--	<input type="button" value="Apply"/>	--	--	
	Ch. 9	--	OFF <input type="text"/>	0.0 <input type="text"/>	--	<input type="button" value="Apply"/>	--	--	
	Ch. 10	--	OFF <input type="text"/>	0.0 <input type="text"/>	--	<input type="button" value="Apply"/>	--	--	
	Ch. 11	--	OFF <input type="text"/>	0.0 <input type="text"/>	--	<input type="button" value="Apply"/>	--	--	
	Ch. 12	--	OFF <input type="text"/>	0.0 <input type="text"/>	--	<input type="button" value="Apply"/>	--	--	
	Ch. 13	--	OFF <input type="text"/>	0.0 <input type="text"/>	--	<input type="button" value="Apply"/>	--	--	
	Ch. 14	--	OFF <input type="text"/>	0.0 <input type="text"/>	--	<input type="button" value="Apply"/>	--	--	
Ch. 15	--	OFF <input type="text"/>	0.0 <input type="text"/>	--	<input type="button" value="Apply"/>	--	--		
Ch. 16	--	OFF <input type="text"/>	0.0 <input type="text"/>	--	<input type="button" value="Apply"/>	--	--		

**SNMP**

Site ID

Description

**Modem Box Setting**

Repeater IP

Subnet Mask

Gateway

**Location**

Latitude

Longitude

**AAI Input**

AAI Input 1

• Figure 5-12 Install Page

### 6.4.2 Technology

This section allows the user to set the repeater mode to either use PS700, PS800, or PS700+PS800.



• **Figure 5-13 Technology**

The following choices are available from the dropdown:

- **PS700 (758-768MHz)**
- **PS800 (851-861MHz)**
- **PS700 +PS800 (758-861MHz)**

### 6.4.3 Band Selection

		PS700				PS800			
		Channel Center Frequency (MHz)	Bandwidth (KHz)	Downlink Gain (dB)	DSP Output Level (dBm)	Set	Downlink Freq (MHz)		
							Start	End	
Broad	PS7( ▾)	--	OFF ▾	0.0 ▾	--	Apply	--	--	
	PS7( ▾)	--	OFF ▾	0.0 ▾	--	Apply	--	--	
Narrow	Ch. 1	--	OFF ▾	0.0 ▾	--	Apply	--	--	
	Ch. 2	--	OFF ▾	0.0 ▾	--	Apply	--	--	
	Ch. 3	--	OFF ▾	0.0 ▾	--	Apply	--	--	
	Ch. 4	--	OFF ▾	0.0 ▾	--	Apply	--	--	
	Ch. 5	--	OFF ▾	0.0 ▾	--	Apply	--	--	
	Ch. 6	--	OFF ▾	0.0 ▾	--	Apply	--	--	
	Ch. 7	--	OFF ▾	0.0 ▾	--	Apply	--	--	
	Ch. 8	--	OFF ▾	0.0 ▾	--	Apply	--	--	
	Ch. 9	--	OFF ▾	0.0 ▾	--	Apply	--	--	
	Ch. 10	--	OFF ▾	0.0 ▾	--	Apply	--	--	
	Ch. 11	--	OFF ▾	0.0 ▾	--	Apply	--	--	
	Ch. 12	--	OFF ▾	0.0 ▾	--	Apply	--	--	
	Ch. 13	--	OFF ▾	0.0 ▾	--	Apply	--	--	
	Ch. 14	--	OFF ▾	0.0 ▾	--	Apply	--	--	
Ch. 15	--	OFF ▾	0.0 ▾	--	Apply	--	--		
Ch. 16	--	OFF ▾	0.0 ▾	--	Apply	--	--		

[Show Freq. Table](#)

• **Figure 5-14 Band Selection**

Band selection allows the user specify the desired frequencies by inputting the center frequencies and selecting the bandwidths.

**Reference Center Frequency:** The user can input the center frequency of the pass-band.

**Bandwidth:** Allows the user to select the desired bandwidth for the passband. Choices for wide band frequencies include 5 and 10MHz. Narrow band choices include 6.25, 12.5, 25.0, and 200 KHz.

**Downlink/Uplink Gain:** Minor gain adjustments can be performed on a per channel basis to equalize signal levels

**Downlink Freq - Start:** Displays the start frequency of the pass-band once the band selection has been set

**Downlink Freq - End:** Displays the end frequency of the pass-band once the band selection has been set

#### 6.4.4 SNMP

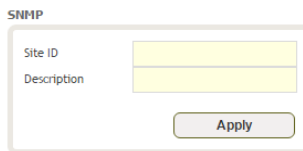

The image shows a web form titled "SNMP". It contains two text input fields: "Site ID" and "Description". Below these fields is an "Apply" button.

• **Figure 5-15 SNMP**

The SNMP section allows you to specify the Site ID and Description. The Site-ID is the code that is used to identify the repeater.

#### 6.4.5 Location

This section allows the user to input the latitude and the longitude of the repeater.

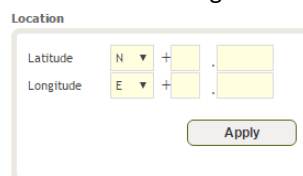

The image shows a web form titled "Location". It has two rows of input fields. The first row is for "Latitude", with a dropdown menu set to "N", a plus sign, and a text input field. The second row is for "Longitude", with a dropdown menu set to "E", a plus sign, and a text input field. Below these fields is an "Apply" button.

• **Figure 5-16 Location Setting**

#### 6.4.6 Modem Box Setting

This section allows the user to specify alternative Repeater IP, Subnet Mask, and Gateway settings. These settings are enabled when the Host/Remote switch is set to the Remote position.

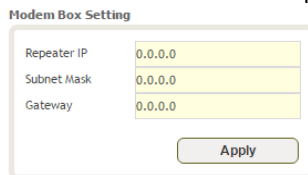

The image shows a web form titled "Modem Box Setting". It contains three text input fields: "Repeater IP" (with the value 0.0.0.0), "Subnet Mask" (with the value 0.0.0.0), and "Gateway" (with the value 0.0.0.0). Below these fields is an "Apply" button.

• **Figure 5-17 Modem Box Setting**

#### 6.4.7 Location Info / Installer Info

This section allows the user to specify the address of the repeater and also the information of the installer.

**Location Info**

Company

Address1

Address2

City

State

ZIP Code

---

**Installer Info**

Company

Name

Phone

E-mail

---

- **Figure 5-18 Repeater Location Info / Repeater Installer Info**

#### 6.4.8 Date & Time

This section allows the user to specify the current date and time.

**Date & Time**

Date

Time

---

- **Figure 5-19 Date & Time Setting**

## 6.5 System

The System tab allows the user to perform firmware updates, upload closeout packages, view any changes to the system, backup existing configuration, and add/remove user accounts, and change the login credentials of the Administrator.

### 6.5.1 System: Account

#### 6.5.1.1 System: Account – Account Management

The Account Management section allows the Administrator to delete any user accounts. Please note that the Account Management section is only available if you are logged into the system as the Administrator. To delete a user account click on the Account Management link and under the Delete column, click on the delete button.

Account Management / New account / Change Password

No	User Name	Password	Status	Last Login	Edit
1	admin	admin	administrator	2022-04-07 19:36:56	-
2	adrf	adrf	user	2022-04-07 19:26:56	delete
3	guest	guest	guest	1970-01-01 00:00:00	delete

• **Figure 5-20 System: Account- Account Management**

#### 6.5.1.2 System: Account – New Account

The New account section allows the Administrator to create a new user account. Please note that the New account section is only available if you are logged into the system as the Administrator. To create a new user account click on the new account link and fill in the fields shown.

Account Management / **New account** / Change Password

user

**Figure 5-21 System: Account- New Account**

#### 6.5.1.3 System: Account – Change Password

The Change Password section allows the current user who is logged into the system to change their login credentials.

Account Management / New account / **Change Password**

admin

admin

admin

Please enter new password.

• **Figure 5-22 System: Account- Change Password**

### 6.5.1.4 System:Log - Event Log

#### 6.5.2 User Log

This section displays system events that have taken place. The Event Log displays who has made the changes, the time and date of when the event took place, and what changes were made to the system. The System Log tracks the following events

- System Initiation
- Alarm Set
- Alarm Clear

**Event Log / User Log**

Seq.	Date / Time	Source	Description	Event	Severity Level
1	2022.04.07 09:18:43	FiRe-78-8	-	[Donor Antenna Disconnection]Donor Antenna Disconnection Donor Antenna Disconnection Alarm Set.	minor
2	2022.04.07 09:18:43	FiRe-78-8	-	[Donor Antenna Disconnection]Donor Antenna Disconnection Donor Antenna Disconnection Alarm Set.	minor
3	2022.04.07 09:17:42	HE-PSR-ANN #1	PSR-ANN	Link Fail Alarm Set.	minor
4	2022.04.07 09:17:23	FiRe-78-8	-	[Battery Not Charge]Battery Not Charge Battery Not Charge Alarm Set.	minor
5	2022.04.07 09:17:03	FiRe-78-8	-	[Door Open]Door Open Door Open Alarm Clear.	minor
6	2022.04.07 09:16:47	FiRe-78-8	-	Signal Low Signal Low Alarm Set.	minor
7	2022.04.07 09:16:47	FiRe-78-8	-	Signal Not Detected Signal Not Det Alarm Set.	minor
8	2022.04.07 09:16:45	[1]FiRe-ODU-8/[8]R-ORU-U/[1]R-3378P-U	-	Downlink Low Output Power Alarm Set.	minor
9	2022.04.07 09:16:45	FiRe-78-8	-	[Battery Fail]Battery Fail Battery Fail Alarm Set.	minor
10	2022.04.07 09:16:42	FiRe-78-8	-	Signal Low Signal Low Alarm Set.	minor
11	2022.04.07 09:16:42	FiRe-78-8	-	Signal Not Detected Signal Not Det Alarm Set.	minor
12	2022.04.07 09:16:42	FiRe-78-8	-	[Door Open]Door Open Door Open Alarm Set.	minor
13	2022.04.07 09:16:42	FiRe-78-8	-	[Battery Low]Battery Low Battery Low Alarm Set.	minor
14	2022.04.07 09:16:42	FiRe-78-8	-	[Battery Not Install]Battery Not Installed Battery Not Install Alarm Set.	minor
15	2022.04.07 09:16:42	FiRe-78-8	-	Service Initiated.	notification

1

• **Figure 5-23 System – Event Log**

#### 6.5.3 System:log– User Log

This section tracks user activity within the system. The User Log displays who has made the changes, the time and date of when the event took place, and what changes were made to the system. The User Log tracks the following items:

- Log in / Log out activity
- Changes to gain/attenuation/output values
- System event generated by user(firmware update, backup/resote, create/delete account)
- DAS Navigation Tree Lock/Unlock
- Description change
- Repeater/installer information change
- Setting date/time



Event Log / **User Log**

Seq.	Date / Time	Source	Description	Username	Log Message
1	2022.04.07 12:38:34	FiRe-78-8	-	admin	User Set ALC Balance On
2	2022.04.07 12:38:34	FiRe-78-8	-	admin	User set ALC 700 UL Offset 9.0
3	2022.04.07 12:38:34	FiRe-78-8	-	admin	User set ALC 700 DL Offset 1.0
4	2022.04.07 12:38:34	FiRe-78-8	-	admin	User set ALC 700 UL Level 21.0
5	2022.04.07 12:38:34	FiRe-78-8	-	admin	User set ALC 700 DL Level -33.0
6	2022.04.07 12:38:34	FiRe-78-8	-	admin	User Set Uplink 700 Gain to 21.5
7	2022.04.07 12:38:34	FiRe-78-8	-	admin	User Set Downlink 700 Gain to 6547.1

1

[Download](#)

• **Figure 5-24 System – User Log**

### 6.5.4 System – Update

To perform a firmware update, click on the Update tab and the following screen will appear.

Settings Update Files

Update File Upload [찾아보기...](#) 파일이 선택되지 않았습니다. [Upload](#)

---

Update File Management  UPDATE\_FiRe8\_700013\_1004\_1002\_1008\_3040.dat

[Update](#) [Download](#) [Delete](#)

Check the available boxes below to select the ADX units to be firmware updated.  
Click the UPDATE button at the bottom of this section to begin the firmware update process.

	Description	Current	Available	Progress	Comment
<input type="checkbox"/>	HE-PSR-ANN #1	PSR-ANN	-	1.0.04	Link fail
<input type="checkbox"/>	[1]FiRe-ODU-8		1.0.02	1.0.02	Not Needed
<input type="checkbox"/>	[8]R-ORU-U		1.0.08	1.0.08	Not Needed
<input type="checkbox"/>	RU-PSR-ANN(Unknown) #1	PSR-ANN	-	1.0.04	Wait Connection
<input type="checkbox"/>	[1]R-3378P-U		3.0.40	3.0.40	Not Needed

[Update](#) [Stop](#)

• **Figure 5-25 System – Update**

Click on the Choose File button and locate the firmware file.  
Click on the Upgrade button to perform the firmware update.

### 6.5.5 System : Backup & Restore

The backup section allows the user to save the settings. To perform the backup, click on the Backup button and system save the backup file. To restore the settings to the system, click on Choose File button, select the backup file, restore unit and click the excute button.

**Settings Files**

Current Setting Save Save

---

Setting File Upload 찾아보기... 파일이 선택되지 않았습니다. Upload

---

Current Selected File

---

Management Select    Download    Delete

---

Check the available boxes below to select the ADXV units to be restore.  
Click the EXECUTE button at the bottom of this section to begin the setting restore process.

Unit list	Progress	Status
<input type="checkbox"/> [0]FiRe-78-8	————	----
<input type="checkbox"/> [1]FiRe-ODU-8	————	----
<input type="checkbox"/> [8]R-ORU-U	————	----
<input type="checkbox"/> [1]R-3378P-U	————	----

Execute    Stop

• **Figure 5-26 System Backup**

### 6.6 Help

If an internet connection is available, clicking on the Help Tab will redirect the user to our Technical Support page.

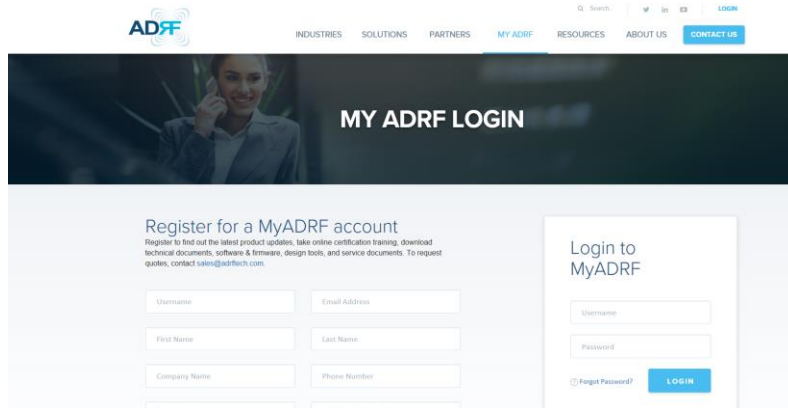

• **Figure 5-27 Help**

### 6.7 Logout

Clicking the Logout button will log the current user off the system.