

# FCC Radio Test Report

## FCC ID: N3A-NWS01OUT

**Report No.** : TB-FCC123997  
**Applicant** : Netatmo  
**Equipment Under Test (EUT)**  
**EUT Name** : Netatmo Weather Station  
**Model No.** : NWS01  
**Serial No.** : N/A  
**Brand Name** : Netatmo  
**Receipt Date** : 2012-05-14  
**Test Date** : 2012-05-15 to 2012-05-25  
**Issue Date** : 2012-05-28  
**Standards** : FCC Part 15, Subpart C  
**Test Method** : ANSI C63.4:2003  
**Conclusions** : **PASS**

In the configuration tested, the EUT complied with the standards specified above,  
The EUT technically complies with the FCC requirements

**Test/Witness Engineer** : *Ray Lai*  
**Approved & Authorized** : *Sally Wong*

This report details the results of the testing carried out on one sample. The results contained in this test report do not relate to other samples of the same product. The manufacturer should ensure that all products in series production are in conformity with the product sample detailed in the report.

## Contents

<b>CONTENTS</b> .....	<b>2</b>
<b>1. GENERAL INFORMATION ABOUT EUT</b> .....	<b>4</b>
1.1 Client Information.....	4
1.2 General Description of EUT (Equipment Under Test) .....	4
1.3 Block Diagram Showing the Configuration of System Tested.....	5
1.4 Description of Support Units .....	5
1.5 Description of Test Mode.....	5
1.6 Description of Test Software Setting .....	6
1.7 Test Facility.....	6
<b>2. TEST SUMMARY</b> .....	<b>7</b>
<b>3. CONDUCTED EMISSION TEST</b> .....	<b>8</b>
3.1 Test Standard and Limit.....	8
3.2 Test Setup.....	8
3.3 Test Procedure.....	8
3.4 Test Equipment Used.....	9
3.5 EUT Operating Mode .....	9
3.6 Test Data.....	9
<b>4. RADIATED EMISSION TEST</b> .....	<b>10</b>
4.1 Test Standard and Limit.....	10
4.2 Test Setup.....	11
4.3 Test Procedure.....	12
4.4 EUT Operating Condition .....	12
4.5 Test Equipment.....	13
4.6 Test Data.....	13
<b>5. RESTRICTED BANDS REQUIREMENT</b> .....	<b>17</b>
5.1 Test Standard and Limit.....	17
5.2 Test Setup.....	17
5.3 Test Procedure.....	17
5.4 EUT Operating Condition .....	18
5.5 Test Equipment.....	18
Test Data .....	19
<b>6. BANDWIDTH TEST</b> .....	<b>21</b>
6.1 Test Setup.....	21
6.2 Test Procedure.....	21
6.3 EUT Operating Condition .....	21
6.4 Test Equipment.....	21
6.5 Test Data.....	21
<b>7. ANTENNA REQUIREMENT</b> .....	<b>23</b>

7.1 Standard Requirement.....	23
7.2 Antenna Connected Construction .....	23
7.3 Result.....	23

## 1. General Information About EUT

### 1.1 Client Information

<b>Applicant</b>	:	Netatmo
<b>Address</b>	:	17, route de la Reine - 92100 Boulogne Billancourt - France
<b>Manufacturer</b>	:	Netatmo
<b>Address</b>	:	17, route de la Reine - 92100 Boulogne Billancourt - France

### 1.2 General Description of EUT (Equipment Under Test)

<b>EUT Name</b>	:	Netatmo Weather Station	
<b>Models No.</b>	:	NWS01	
<b>Model Difference</b>	:	N/A.	
<b>Product Description</b>	:	Operation Frequency: RF: 916 MHz	
		Number of Channels:	RF: 1 channel 916MHz
		Out Power	RF(916MHz):89.70 dBuV/m@3m
		Antenna Gain:	2.0 dBi
		Modulation Type:	RF(916MHz):GFSK
<b>Power Supply</b>	:	DC Voltage supplied by AAA battery.	
<b>Power Rating</b>	:	DC 6.0V by 4*AAA batteries	
<b>Connecting I/O Port(S)</b>	:	Please refer to the User's Manual	

**Note:**

(1) For a more detailed features description, please refer to the manufacturer's specifications or the User's Manual.

(2) Channel List:

<b>Channel</b>	<b>Frequency (MHz)</b>
CH 1	916

### 1.3 Block Diagram Showing the Configuration of System Tested

Mode 1: TX Mode

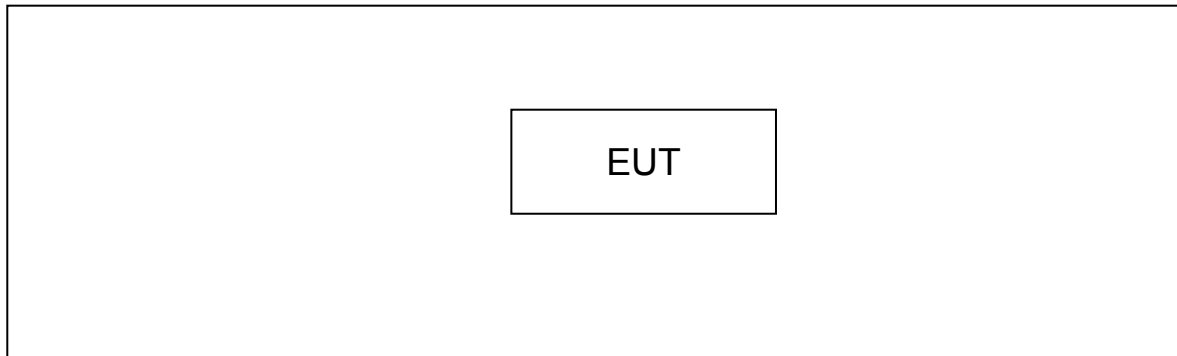

### 1.4 Description of Support Units

Name	Model	S/N	Manufacturer	Used “√”

### 1.5 Description of Test Mode

To investigate the maximum EMI emission characteristics generates from EUT, the test system was pre-scanning tested base on the consideration of following EUT operation mode or test configuration mode which possible have effect on EMI emission level. Each of these EUT operation mode(s) or test configuration mode(s) mentioned follow was evaluated respectively.

For Conducted Test	
Final Test Mode	Description

For Radiated Test	
Final Test Mode	Description
Mode 1	TX Mode 916MHz

**Note:**

- (1) The measurements are performed at the highest, middle, lowest available channels.
- (2) During the testing procedure, the continuously transmitting mode was programmed by the customer.

## 1.6 Description of Test Software Setting

During testing channel & Power controlling software provided by the customer was used to control the operating channel as well as the output power level. The RF output power selection is for the setting of RF output power expected by the customer and is going to be fixed on the firmware of the final end product power parameters of RF mode.

Test Software Version	Test Program: netatmomfgtests.exe
Frequency	916MHz

## 1.7 Test Facility

The tests were performed at:

Bontek Compliance Testing Laboratory Ltd

1/F., Block East H-3, OCT Eastern Ind. Zone, Qiaocheng East Road, Nanshan, Shenzhen, 518055 China

Tel: 86-755-86337020 Fax: 86-755-86337028

At the time of testing, the Laboratory is accredited. It is listed in the United States of American Federal Communications Commission (FCC), and the registration number is 338263.

The test report was fulfilled by Shenzhen Meihua Electronic Co., Ltd. Shenzhen Meihua Electronic Technology Co., Ltd. is assumed full responsibility for the accuracy and completeness of these measurements results.

## 2. Test Summary

FCC Part 15 Subpart C(15.249)			
Standard Section	Test Item	Judgment	Remark
15.203	Antenna Requirement	PASS	N/A
15.205	Restricted Bands	PASS	N/A
15.207	Conducted Emission	N/A(2)	
15.249 &15.209	Radiated Spurious Emission	PASS	N/A
15.215(C)	20dB Bandwidth	PASS	N/A
<b>Note:</b> (1) N/A is an abbreviation for Not Applicable. (2) The Equipment for the outdoor use, and voltage supplied by battery, so no need to test Conducted Emission.			

### 3. Conducted Emission Test

#### 3.1 Test Standard and Limit

##### 3.1.1 Test Standard

FCC Part 15.207

##### 3.1.2 Test Limit

**Conducted Emission Test Limit**

Frequency	Maximum RF Line Voltage (dB $\mu$ V)	
	Quasi-peak Level	Average Level
150kHz~500kHz	66 ~ 56 *	56 ~ 46 *
500kHz~5MHz	56	46
5MHz~30MHz	60	50

Notes:

(1) \*Decreasing linearly with logarithm of the frequency.

(2) The lower limit shall apply at the transition frequencies.

(3) The limit decrease in line with the logarithm of the frequency in the range of 0.15 to 0.50MHz.

#### 3.2 Test Setup

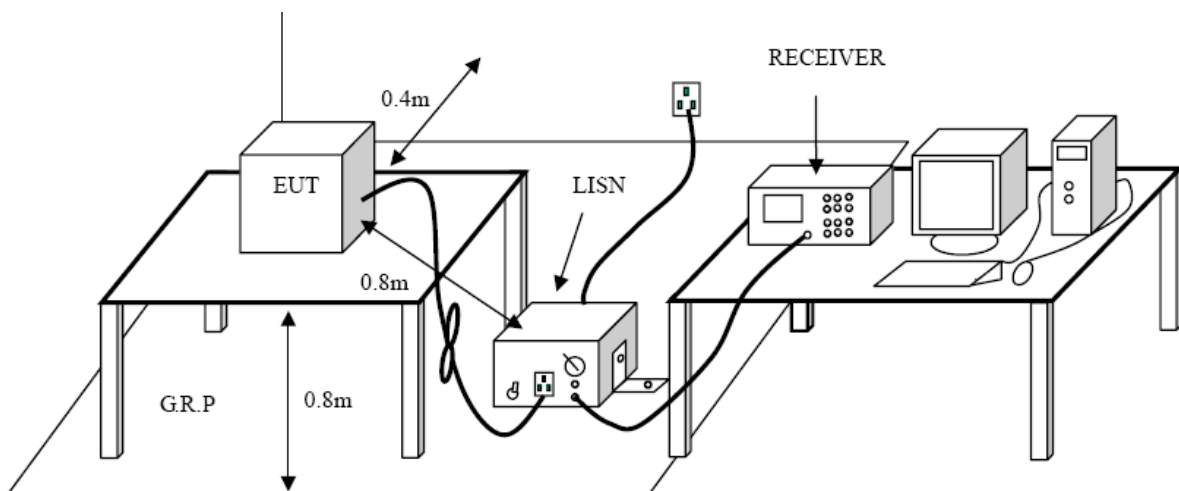

#### 3.3 Test Procedure

The EUT was placed 0.8 meters from the horizontal ground plane with EUT being connected to the power mains through a line impedance stabilization network (LISN). All other support equipments powered from additional LISN(s). The LISN provide 50 Ohm/ 50uH of coupling impedance for the measuring instrument.

Interconnecting cables that hang closer than 40 cm to the ground plane shall be folded back and forth in the center forming a bundle 30 to 40 cm long.



I/O cables that are not connected to a peripheral shall be bundled in the center. The end of the cable may be terminated, if required, using the correct terminating impedance. The overall length shall not exceed 1 m.

LISN at least 80 cm from nearest part of EUT chassis.

The bandwidth of EMI test receiver is set at 9kHz, and the test frequency band is from 0.15MHz to 30MHz.

### 3.4 Test Equipment Used

Description	Manufacturer	Model No.	Serial No.	Cal. Date	Cal. Date
EMI Test Receiver	ROHDE& SCHWARZ	ESC30	DE25181	2011-08-11	2012-08-11
50ΩCoaxial Switch	Anritsu	MP59B	X10321	2011-08-11	2012-08-11
L.I.S.N	EMCO	3624/1	00063417	2011-08-11	2012-08-11
L.I.S.N	EMCO	3624/1	00063417	2011-08-11	2012-08-11

### 3.5 EUT Operating Mode

Please refer to the description of test mode.

### 3.6 Test Data

The equipment is supplied by DC power from batter, so the test item is not applicable.

## 4. Radiated Emission Test

### 4.1 Test Standard and Limit

#### 4.1.1 Test Standard

FCC Part 15.209

#### 4.1.2 Test Limit

#### Radiated Emission Limit(9kHz~1000MHz)

Frequency (MHz)	Field Strength (microvolt/meter)	Measurement Distance (meters)
0.009~0.490	2400/F(KHz)	300
0.490~1.705	24000/F(KHz)	30
1.705~30.0	30	30
30~88	100	3
88~216	150	3
216~960	200	3
Above 960	500	3

#### Radiated Emission Limit (Above 1000MHz)

Frequency (MHz)	Class A (dBuV/m)(at 3 M)		Class B (dBuV/m)(at 3 M)	
	Peak	Average	Peak	Average
Above 1000	80	60	74	54

#### Note:

- (1) The tighter limit applies at the band edges.
- (2) Emission Level(dBuV/m)=20log Emission Level(Uv/m)

#### Limits of radiated emission measurement (15.249)

FCC Part 15 (15.249), Subpart C	
Limit	Frequency Range (MHz)
Field strength of fundamental 50000 $\mu$ V/m (94 dB $\mu$ V/m) @ 3 m	902~928

### 4.2 Test Setup

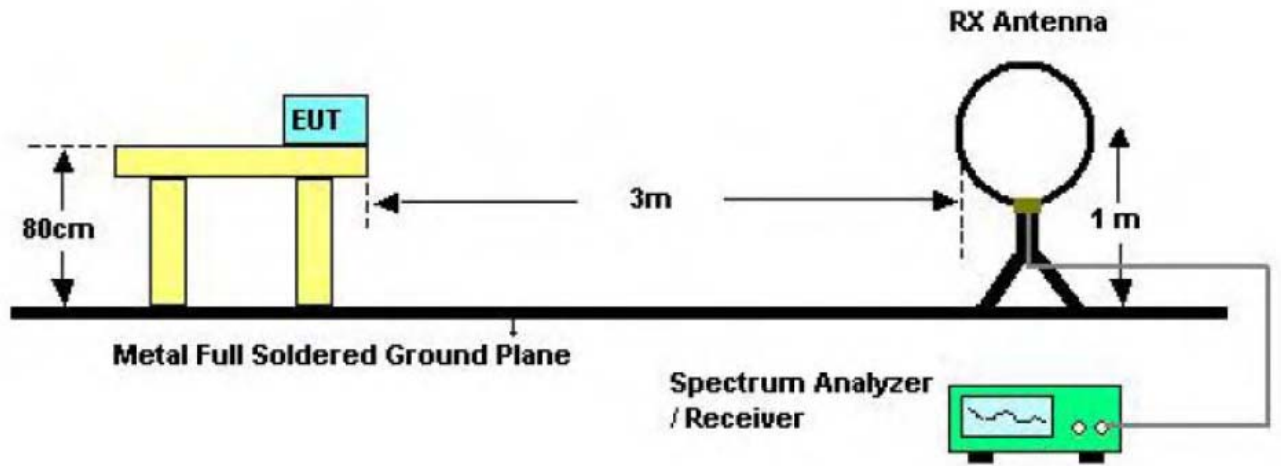

Bellow 30MHz Test Setup

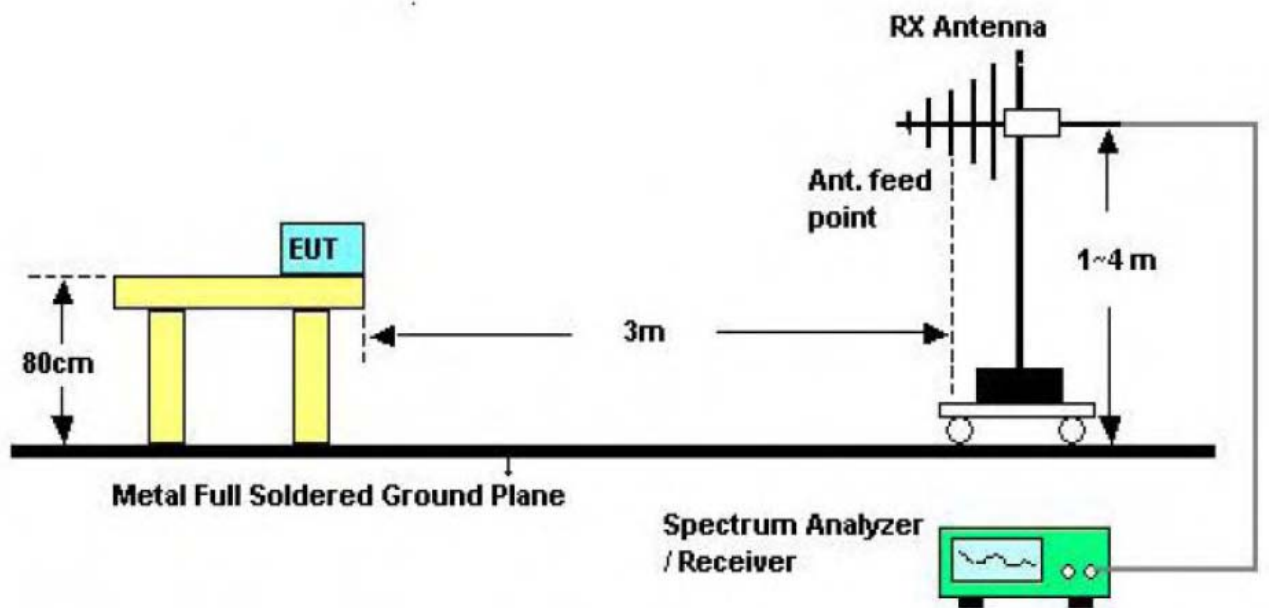

Bellow 1000MHz Test Setup

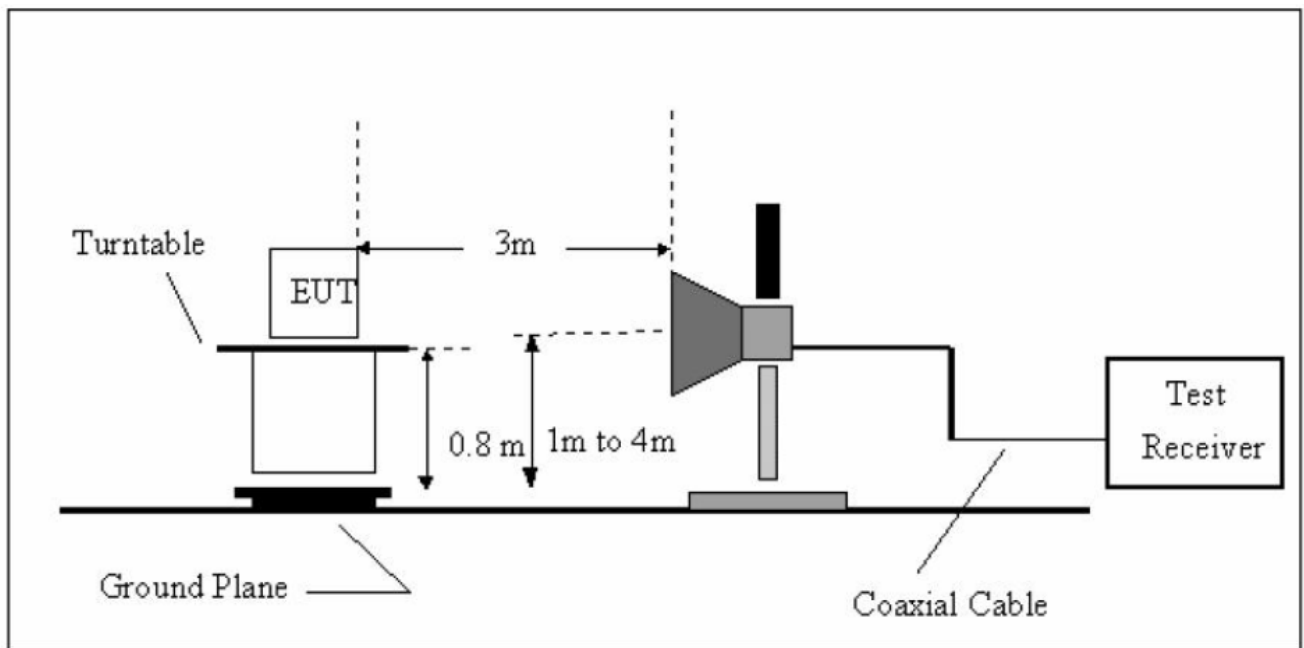

Above 1GHz Test Setup

#### 4.3 Test Procedure

- (1) The measuring distance of 3m shall be used for measurements at frequency up to 1GHz and above 1 GHz. The EUT was placed on a rotating 0.8m high above ground, the table was rotated 360 degrees to determine the position of the highest radiation.
- (2) The Test antenna shall vary between 1m and 4m, Both Horizontal and Vertical antenna are set to make measurement.
- (3) The initial step in collecting conducted emission data is a spectrum analyzer peak detector mode pre-scanning the measurement frequency range. Significant peaks are then marked and then Quasi Peak detector mode re-measured.
- (4) If the Peak Mode measured value compliance with and lower than Quasi Peak Mode Limit Bellow 1 GHz, the EUT shall be deemed to meet QP Limits and then no additional QP Mode measurement performed. But the Peak Value and average value both need to comply with applicable limit above 1 GHz.
- (5) For the actual test configuration, please see the test setup photo.

#### 4.4 EUT Operating Condition

The Equipment Under Test was set to Continual Transmitting in maximum power.

#### 4.5 Test Equipment

Description	Manufacturer	Model No.	Serial No.	Cal. Date	Cal. Date
Spectrum Analyzer	ROHDE& SCHWARZ	FSEA20	DE25181	2011-08-12	2012-08-11
Positioning Controller	C&C	CC-C-1F	N/A	2011-08-12	2012-08-11
Trilog Broadband Antenna	SCHWARZBEC K	VULB9163	9163-333	2011-07-21	2012-07-20
Horn Antenna	SCHWARZBEC K	BBHX 9120	9120-426	2011-07-21	2012-07-20
RF Switch	EM	EMSW18	SW060023	2011-08-12	2012-08-11
Amplifier	Agilent	8447F	3113A06717	2011-08-12	2012-08-11
Coaxial Cable	SCHWARZBEC K	AK9513	9513-10	2011-08-12	2012-08-11
EMI Test Receiver	ROHDE& SCHWARZ	ESPI	25498514	2011-08-12	2012-08-11
EMI Test Receiver	ROHDE& SCHWARZ	ESI26	838786/103	2011-08-12	2012-08-11
Receiver Horn Antenna	ROHDE& SCHWARZ	HF906	100013	2011-08-12	2012-08-11

#### 4.6 Test Data

Please see the next page.

**Fundamental Power**

<b>Freq. (MHz)</b>	<b>Ant.Pol. H/V</b>	<b>Emission Level (dBuV/m) PK</b>	<b>Limit3m (dBuV/m) PK</b>	<b>Margin(dB)</b>
916.000	V	86.80	94	7.20
916.000	H	89.70	94	4.30

### Spurious Emission Bellow 1GHz

Operation Mode: TX 916MHz      Test Date : May 24, 2012  
 Frequency Range: 30~1000MHz      Temperature : 28 °C  
 Measured Distance: 3m      Humidity : 65 %  
 Test Voltage: DC 6.0V

Freq. (MHz)	Ant.Pol. H/V	Emission Level (dBuV)	Limit (3m) (dBuV/m)	Margin (dB)	Note
56.50	H	28.04	40.00	11.96	PK
165.70	H	30.11	43.50	13.39	PK
227.80	H	31.67	46.00	14.33	PK
360.10	H	32.96	46.00	13.04	PK
464.85	H	31.82	46.00	14.18	PK
560.62	H	33.36	46.00	12.64	PK
85.60	V	28.46	40.00	11.54	PK
145.80	V	30.66	43.50	12.84	PK
263.90	V	31.95	46.00	14.05	PK
467.20	V	32.30	46.00	13.70	PK
542.10	V	31.24	46.00	14.76	PK
611.50	V	33.77	46.00	12.23	PK

- Note:**
- (1) All Readings are Peak Value.
  - (2) Emission Level= Reading Level+ Probe Factor +Cable Loss
  - (3) The average measurement was not performed when the peak measured data under the limit of average detection.

### Harmonics emissions

Operation Mode: TX 916MHz      Test Date : May 24, 2012  
 Frequency Range: 1-25GHz      Temperature : 28 °C  
 Measured Distance: 3m      Humidity : 65 %  
 Test Voltage: DC 3.7V

Freq. (MHz)	Ant.Pol. H/V	Emission Level (dBuV/m)		Limit3m (dBuV/m)		Margin(dB)	
		PK	AV	PK	AV	PK	AV
1831.700	V	46.22	44.61	74.00	54.00	27.78	9.39
2747.900	V	41.27	38.84	74.00	54.00	32.73	15.16
--	V	--	--	74.00	54.00	--	--
--	V	--	--	74.00	54.00	--	--
--	V	--	--	74.00	54.00	--	--
1831.700	H	48.07	45.16	74.00	54.00	25.93	8.84
2747.900	H	42.30	39.95	74.00	54.00	31.70	14.05
--	H	--	--	74.00	54.00	--	--
--	H	--	--	74.00	54.00	--	--
--	H	--	--	74.00	54.00	--	--

**Other harmonics emissions are lower than 20dB below the allowable limit.**

- Note:**
- (1) All Readings are Peak Value and AV.
  - (2) Emission Level= Reading Level + Probe Factor +Cable Loss
  - (3) Data of measurement within this frequency range shown "--" in the table above means the reading of emissions are attenuated more than 20dB below the permissible limits or the field strength is too small to be measured.
  - (4) For above 1GHz radiated emissions  
 Peak value set RBW/VBW: 1MHz/1MHz;  
 Average value set RBW/VBW: 1MHz/10Hz



## 5. Restricted Bands Requirement

### 5.1 Test Standard and Limit

#### 5.1.1 Test Standard

FCC Part 15.209

FCC Part 15.205

#### 5.1.2 Test Limit

Restricted Frequency Band (MHz)	Class B (dBuV/m)(at 3 M)
608 ~614	Attenuated by at least 50 dB below the level of the fundamental or to the general radiated emission limits in 15.209, whichever is the lesser attenuation
960 ~1240	

### 5.2 Test Setup

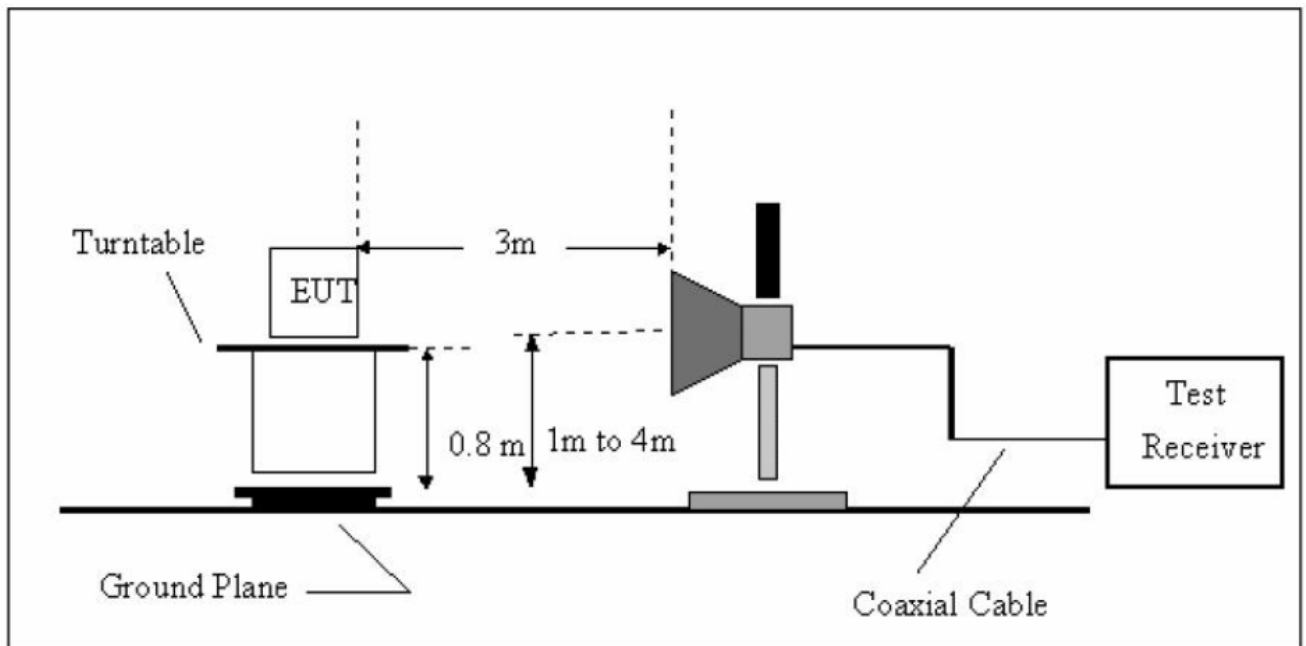

### 5.3 Test Procedure

- (1) The measuring distance of 3m shall be used for measurements at frequency up to 1GHz and above 1 GHz. The EUT was placed on a rotating 0.8m high above ground, the table was rotated 360 degrees to determine the position of the highest radiation.
- (2) The Test antenna shall vary between 1m and 4m, Both Horizontal and Vertical antenna are set to make measurement.
- (3) The initial step in collecting conducted emission data is a spectrum analyzer peak detector

mode pre-scanning the measurement frequency range. Significant peaks are then marked and then Quasi Peak detector mode re-measured.

- (4) If the Peak Mode measured value compliance with and lower than Quasi Peak Mode Limit Bellow 1 GHz, the EUT shall be deemed to meet QP Limits and then no additional QP Mode measurement performed. But the Peak Value and average value both need to comply with applicable limit above 1 GHz.
- (5) For the actual test configuration, please see the test setup photo.

#### 5.4 EUT Operating Condition

The Equipment Under Test was set to Continual Transmitting in maximum power.

#### 5.5 Test Equipment

Description	Manufacturer	Model No.	Serial No.	Cal. Date	Cal. Date
Spectrum Analyzer	ROHDE& SCHWARZ	FSEA20	DE25181	2011-08-12	2012-08-11
Positioning Controller	C&C	CC-C-1F	N/A	2011-08-12	2012-08-11
Trilog Broadband Antenna	SCHWARZBEC K	VULB9163	9163-333	2011-07-21	2012-07-20
Horn Antenna	SCHWARZBEC K	BBHX 9120	9120-426	2011-07-21	2012-07-20
RF Switch	EM	EMSW18	SW060023	2011-08-12	2012-08-11
Amplifier	Agilent	8447F	3113A06717	2011-08-12	2012-08-11
Coaxial Cable	SCHWARZBEC K	AK9513	9513-10	2011-08-12	2012-08-11
EMI Test Receiver	ROHDE& SCHWARZ	ESPI	25498514	2011-08-12	2012-08-11
EMI Test Receiver	ROHDE& SCHWARZ	ESI26	838786/103	2011-08-12	2012-08-11
Receiver Horn Antenna	ROHDE& SCHWARZ	HF906	100013	2011-08-12	2012-08-11

## Test Data

Spectrum Detector: PK  
Temperature : 28 °C

Test Date : May 24, 2012  
Humidity : 65 %

## 1. Lower Band Edge

Frequency (MHz)	Peak Power Output(dBuV)	Emission Read Value(dBuV)	Result of Band edge(dBc)	Band edge Limit(dBc)
608~614	81.73	22.56	59.17	>50dBc

## 2. Upper Band Edge

Frequency (MHz)	Peak Power Output(dBuV)	Emission Read Value(dBuV)	Result of Band edge(dBc)	Band edge Limit(dBc)
960~1240	81.23	22.16	59.07	>50dBc

### Lower Band Edge

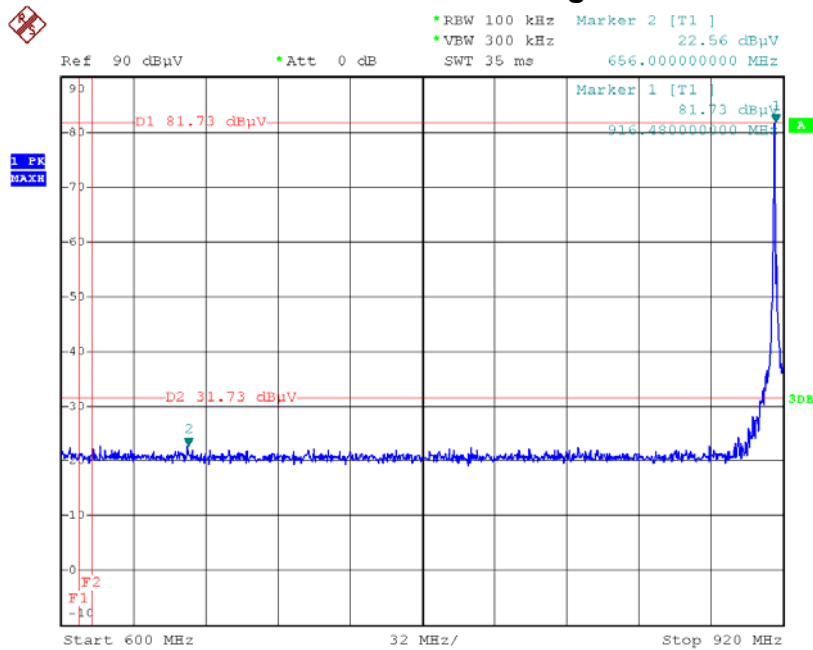

Date: 25.MAY.2012 14:24:31

### Upper Band Edge

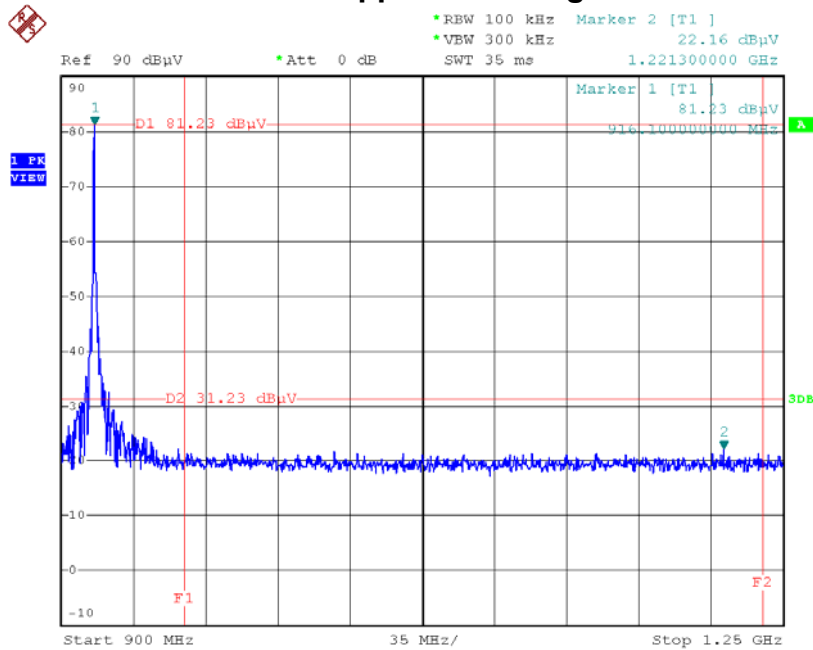

Date: 25.MAY.2012 14:22:12

## 6. Bandwidth Test

### 6.1 Test Setup

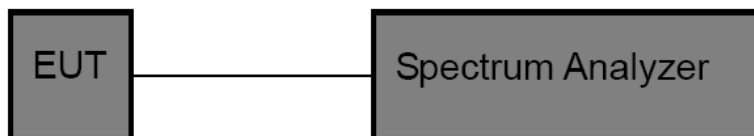

### 6.2 Test Procedure

- (1) The EUT was directly connected to the spectrum analyzer and antenna output port as show in the block diagram above.
- (2) Spectrum Setting:  
Bandwidth: RBW=100 kHz, VBW=100kHz.
- (3) The bandwidth is measured at an amplitude level reduced 20dB from the reference level. The reference level is the level of the highest amplitude signal observed from the transmitter at the fundamental frequency. Once the reference level is established, the equipment is conditioned with typical modulating signal to produce the worst –case (i.e the widest) bandwidth.

### 6.3 EUT Operating Condition

The EUT was set to continuously transmitting for the Bandwidth Test.

### 6.4 Test Equipment

Description	Manufacturer	Model No.	Serial No.	Cal. Date	Cal. Date
Spectrum Analyzer	ROHDE& SCHWARZ	FSEA20	DE25181	2011-08-12	2012-08-11

### 6.5 Test Data

Channel number	Channel frequency (MHz)	20dB Bandwidth (KHz)	99% OBW (MHz)
CH 1	916	334	292

916 MHz

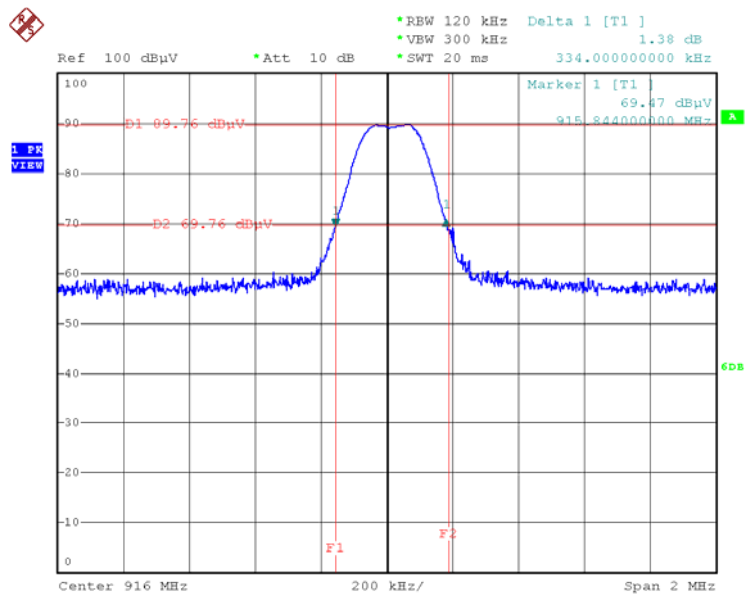

Date: 25.MAY.2012 10:11:30

## 7. Antenna Requirement

### 7.1 Standard Requirement

#### 7.1.1 Standard

FCC Part 15.203

#### 7.1.2 Requirement

An intentional radiator shall be designed to ensure that no antenna other than that furnished by the responsible party shall be used with the device. The use of a permanently attached antenna or of an antenna that uses a unique coupling to the intentional radiator shall be considered sufficient to comply with the provisions of this Section. The manufacturer may design the unit so that a broken antenna can be replaced by the user, but the use of a standard antenna jack or electrical connector is prohibited.

### 7.2 Antenna Connected Construction

The directional gains of the antenna used for transmitting is 0 Bi, and the antenna de-signed with permanent attachment and no consideration of replacement. Please see the EUT photo for details.

### 7.3 Result

The EUT antenna is an Integral Antenna. It complies with the standard requirement.