



Test Report

FCC ID: N2S-SC44E-235470

FCC Rule Part: 90Y

Report Number: AT72150545-2C0

Manufacturer: Silvus Technologies, Inc.
Model: SC4480E-235470-SBST

Test Begin Date: September 16, 2019
Test End Date: September 26, 2019

Report Issue Date: October 22, 2019



FOR THE SCOPE OF ACCREDITATION UNDER Certificate Number: 2955.09

This report must not be used by the client to claim product certification, approval, or endorsement by A2LA, NIST, or any agency of the Federal Government.

Prepared By:

Handwritten signature of Jeremy Pickens in black ink.

**Jeremy Pickens
Senior Wireless Engineer
TÜV SÜD America Inc.**

Reviewed by:

Handwritten signature of Ryan McGann in black ink.

**Ryan McGann
Team Leader
TÜV SÜD America Inc.**

This test report shall not be reproduced except in full. This report may be reproduced in part with prior written consent of TÜV SÜD America Inc. The results contained in this report are representative of the sample(s) submitted for evaluation.

This report contains 25 pages

TABLE OF CONTENTS

1	GENERAL	3
1.1	PURPOSE	3
1.2	APPLICANT INFORMATION	3
1.3	PRODUCT DESCRIPTION	3
1.4	TEST METHODOLOGY AND CONSIDERATIONS	3
2	TEST FACILITIES	4
2.1	LOCATION	4
2.2	LABORATORY ACCREDITATIONS/RECOGNITIONS/CERTIFICATIONS	4
2.3	RADIATED EMISSIONS TEST SITE DESCRIPTION	5
2.3.1	<i>Semi-Anechoic Chamber Test Site – Chamber A</i>	5
2.3.2	<i>Semi-Anechoic Chamber Test Site – Chamber B</i>	6
3	APPLICABLE STANDARD REFERENCES	7
4	LIST OF TEST EQUIPMENT	7
5	SUPPORT EQUIPMENT.....	8
6	EQUIPMENT UNDER TEST SETUP BLOCK DIAGRAM.....	8
7	SUMMARY OF TESTS.....	9
7.1	26dB BANDWIDTH AND EMISSION MASK – §2.1049 / §90.210(M).....	9
7.1.1	<i>Measurement Procedure</i>	9
7.1.2	<i>Measurement Results</i>	9
7.2	FUNDAMENTAL EMISSION OUTPUT POWER – §90.1215(A)(1)	12
7.2.1	<i>Measurement Procedure</i>	12
7.2.2	<i>Measurement Results</i>	12
7.3	POWER SPECTRAL DENSITY (PSD) – §90.1215(A)(2)	13
7.3.1	<i>Measurement Procedure</i>	13
7.3.2	<i>Measurement Results</i>	13
7.4	PEAK EXCURSION – §90.1215(E)	14
7.4.1	<i>Measurement Procedure</i>	14
7.4.2	<i>Measurement Results</i>	14
7.5	MAXIMUM PERMISSIBLE EXPOSURE – §90.1217 / §1.1310	15
7.5.1	<i>Measurement Procedure</i>	15
7.5.2	<i>Results</i>	15
7.6	ANTENNA PORT CONDUCTED SPURIOUS EMISSIONS - §90.210(M) / §2.1051	16
7.6.1	<i>Measurement Procedure</i>	16
7.6.2	<i>Measurement Results</i>	16
7.7	RADIATED SPURIOUS EMISSIONS / CABINET RADIATION - §90.210(M)	18
7.7.1	<i>Measurement Procedure</i>	18
7.7.2	<i>Measurement Results</i>	18
7.7.3	<i>Sample Calculation:</i>	19
7.8	FREQUENCY STABILITY - §90.213(A) / §2.1055	20
7.8.1	<i>Measurement Procedure</i>	20
7.8.2	<i>Measurement Results</i>	20
8	ESTIMATION OF MEASUREMENT UNCERTAINTY	21
9	CONCLUSION.....	21
APPENDIX A: PLOTS		22

1 GENERAL

1.1 Purpose

The purpose of this report is to demonstrate compliance with Part 90 Subpart Y of the FCC’s Code of Federal Regulations for the tests documented herein.

1.2 Applicant Information

Silvus Technologies, Inc.
 10990 Wilshire Blvd., #1500
 Los Angeles, CA 90024 USA

1.3 Product Description

The DUT is a 4x4 MIMO radio operating in the licensed 4940-4990MHz band.

Technical Details:

Detail	Description
Frequency Range (MHz)	4945 - 4985
Number of Channels	9
Channel Spacing	5 MHz
Modulation Format	OFDM
Data Rates	100Mbps
Operating Voltage	12Vdc via 100-240Vac 50/60Hz Adapter
Antenna Type(s) / Gain(s)	Dual-Band Omni Antenna, Half Wave Dipole / 2.5dBi (Southwest Antennas, P/N: 1001-071)

Test Sample Serial Number(s): SC44-18569

Test Sample Condition: The equipment was provided in good condition without any physical damage.

1.4 Test Methodology and Considerations

All modes of operation, including all data rates, were evaluated and the data presented in this report represents the worst case where applicable.

For radiated emissions, the EUT was evaluated in the orientation of intended mounting. . Antenna ports were terminated through attenuators into 50-Ohm loads.

Power setting during test: Antenna Port 1: 50
 Antenna Port 2: 48(LCH) / 49(MCH) / 50(HCH)
 Antenna Port 3: 52
 Antenna Port 4: 48

2 TEST FACILITIES

2.1 Location

The radiated and conducted emissions test sites are located at the following addresses:

TÜV SÜD America, Inc.
5945 Cabot Pkwy, Suite 100
Alpharetta, GA 30005
Phone: (678) 341-5900

2.2 Laboratory Accreditations/Recognitions/Certifications

TÜV SÜD America, Inc. is accredited to ISO/IEC 17025 by the American Association for Laboratory Accreditation/A2LA accreditation program and has been issued certificate number 2955.09 in recognition of this accreditation.

Unless otherwise specified, all tests methods described within this report are covered under the ISO/IEC 17025 scopes of accreditation.

The Semi-Anechoic Chamber Test Sites and Conducted Emissions Sites have been fully described, submitted to, and accepted by the FCC, ISED Canada and the Japanese Voluntary Control Council for Interference by information technology equipment.

FCC Designation Accreditation Number:	US1233
ISED Canada Lab Code:	23932
VCCI Member Number:	1831
• VCCI Registration Number	A-0295

2.3 Radiated Emissions Test Site Description

2.3.1 Semi-Anechoic Chamber Test Site – Chamber A

The Semi-Anechoic Chamber Test Site consists of a 20' x 30' x 18' shielded enclosure. The chamber is lined with Toyo Ferrite Grid Absorber, model number FFG-1000. The ferrite tile grid is 101 x 101 x 19mm thick and weighs approximately 550 grams. These tiles are mounted on steel panels and installed directly on the inner walls of the chamber.

The turntable is 5' in diameter and is located 5'6" from the back wall of the chamber. The chamber is grounded via 1 - 8' copper ground rod, installed at the center of the back wall, it is bound to the ground plane using 3/4" stainless steel braided cable.

The turntable is all steel, flush mounted EMCO Model 1060 installed in an all steel frame. The table is remotely operated from inside the control room located 25' from the range. The turntable is electrically bonded to the surrounding ground plane via steel fingers installed on the edge of the turn table. The steel fingers make constant contact with the ground plane during operation.

Behind the turntable is a 3' x 6' x 4' deep shielded pit used for support equipment if necessary. The pit is equipped with 1 - 4" PVC chase from the turntable to the pit that allows for cabling to the EUT if necessary. The underside of the turntable can be accessed from the pit so cables can be supplied to the EUT from the pit.

The chamber rear wall is covered with a mixture of Siepel pyramidal absorber. The side walls of the chamber are partially covered with Siepel pyramidal absorber.

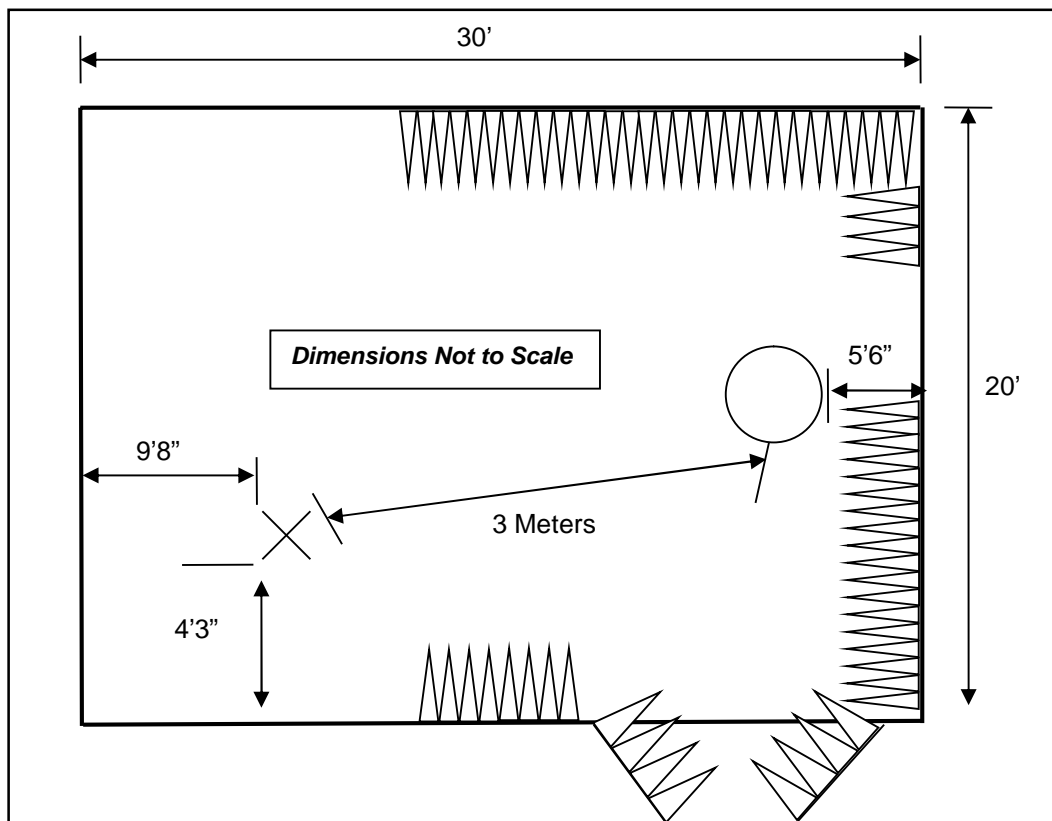

Figure 2.3.1-1: Semi-Anechoic Chamber Test Site – Chamber A

2.3.2 Semi-Anechoic Chamber Test Site – Chamber B

The Semi-Anechoic Chamber Test Site consists of a 20'W x 30'L x 20'H shielded enclosure. The chamber is lined with ETS-Lindgren Ferrite Absorber, model number FT-1500. The ferrite tile 600 mm x 600 mm (2.62 in x 23.62 in) panels and are mounted directly on the inner walls of the chamber shield.

The specular regions of the chamber are lined with additional ETS-Lindgren PS-600 hybrid absorber to extend its frequency range up to 18GHz and beyond.

The turntable is a 2m ETS-Lindgren Model 2170, and installed off the center axis is located 5'6" from the back wall of the chamber. The chamber is grounded via 1 - 8' copper ground rod, installed at the center of the back wall, it is bound to the shield using #8 solid copper wire.

The antenna mast is an EMCO 1060 and is remotely controlled from the control room for both antenna height and polarization.

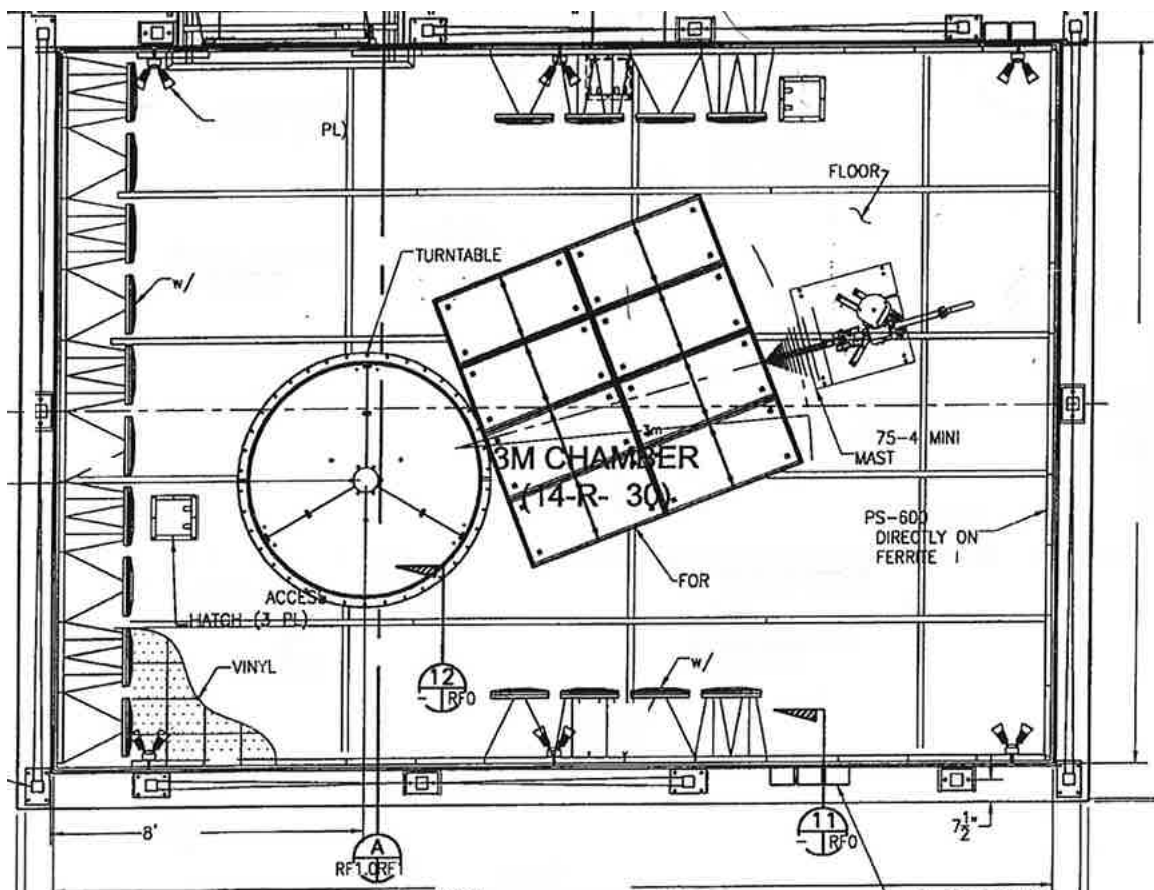

Figure 2.3.2-1: Semi-Anechoic Chamber Test Site – Chamber B

3 APPLICABLE STANDARD REFERENCES

The following standards were used:

- ❖ ANSI C63.26-2015: American National Standard for Compliance Testing of Transmitters Used in Licensed Radio Services.
- ❖ US Code of Federal Regulations (CFR): Title 47, Part 2, Subpart J: Equipment Authorization Procedures, 2019
- ❖ US Code of Federal Regulations (CFR): Title 47, Chapter I, Subchapter D, Part 90, Subpart Y: Regulations Governing Licensing and Use of Frequencies in the 4940-4990 MHz Band, 2019
- ❖ KDB 662911 D01 Multiple Transmitter Output v02r01 - Emissions Testing of Transmitters with Multiple Outputs in the Same Band, October 31, 2013
- ❖ KDB 971168 D01 Power Meas License Digital Systems v03r01 - Measurement Guidance for Certification of Licensed Digital Transmitters
- ❖ KDB 971168 D02 Misc Rev Approv License Devices v02r01 – Miscellaneous and Basic Review and Approval Items for Transmitting Equipment Used in Licensed Radio Services

4 LIST OF TEST EQUIPMENT

The calibration interval of test equipment is annually or the manufacturer's recommendations. Where the calibration interval deviates from the annual cycle based on the instrument manufacturer's recommendations, it shall be stated below.

Table 4-1: Test Equipment

Asset ID	Manufacturer	Model	Equipment Type	Serial Number	Last Calibration Date	Calibration Due Date
22	Hewlett Packard	8449B	High Frequency Pre-Amp	3008A00526	07/11/2018	07/11/2020
213	TEC	PA 102	Amplifier	44927	07/22/2019	07/22/2020
329	A.H.Systems	SAS-571	Horn Antenna	721	8/27/2019	8/27/2020
332	Rohde & Schwarz	TS-PR40	40GHz Pre-Amp	100021	03/13/2018	03/13/2020
333	Rohde & Schwarz	3160-10	HF Antenna - 26.5-40GHz	45576	NCR	NCR
335	Suhner	SF-102A	Cable (40GHZ)	882/2A	7/8/2019	7/8/2020
345	Suhner Sucoflex	102A	Cable 42(GHZ)	1077/2A	7/8/2019	7/8/2020
622	Rohde & Schwarz	FSV40 (v3.40)	FSV Signal Analyzer 10Hz to 40GHz	101338	07/30/2018	07/30/2020
651	Rohde & Schwarz	TS-PR26	18GHz to 26.5GHz Pre-Amplifier	100023	07/10/2019	7/10/2020
652	Rohde & Schwarz	3160-09	High Frequency Antenna 18GHz to 26.5GHz	060922-21894	NCR	NCR
694	Thermotron	S-1.2C	Thermotron temperature chamber	19753	NCR	NCR
695	Fluke	51II	Digital Thermometer	76440097	06/05/2019	06/05/2020
819	Rohde & Schwarz	ESR26	EMI Test Receiver	101345	11/06/2018	11/06/2019
827	(-)	TS8997 Rack Cable Set	TS8997 Rack Cable Set	N/A	05/01/2019	05/01/2020
836	ETS Lindgren	SAC Cable Set	SAC Cable Set includes 620, 837, 838	N/A	05/01/2019	05/01/2020
853	Teseq	CBL 6112D; 6804.17.A	Bilog Antenna; Attenuator	51616; 20181110A	10/15/2018	10/15/2019

NCR = No Calibration Required

NOTE: All test equipment was used only during active calibration cycles as reported above.

5 SUPPORT EQUIPMENT

Table 5-1: Support Equipment

Item	Equipment Type	Manufacturer	Model Number	Serial Number
1	AC/DC Supply	Edac Power Elec.	EA10523C-120	Not Labeled
2	Push-To-Talk	Impact	PRSM-HD7-WP	Not Labeled
3	Laptop	Dell	Latitude 3490	18101036450

Table 5-2: Cable Description

Item	Cable Type	Length	Shield	Termination
A	DC Power	1.2m	Yes	1 - EUT
B	AC Power	1.5m	No	Mains - 1
C	PTT Cable	0.8 m (Coiled)	Yes	EUT – 2
D	AUX / USB	2.8m	Yes	EUT – Unterminated
E	PRI / Ethernet	10m (Extended)	Yes	EUT – 3

6 EQUIPMENT UNDER TEST SETUP BLOCK DIAGRAM

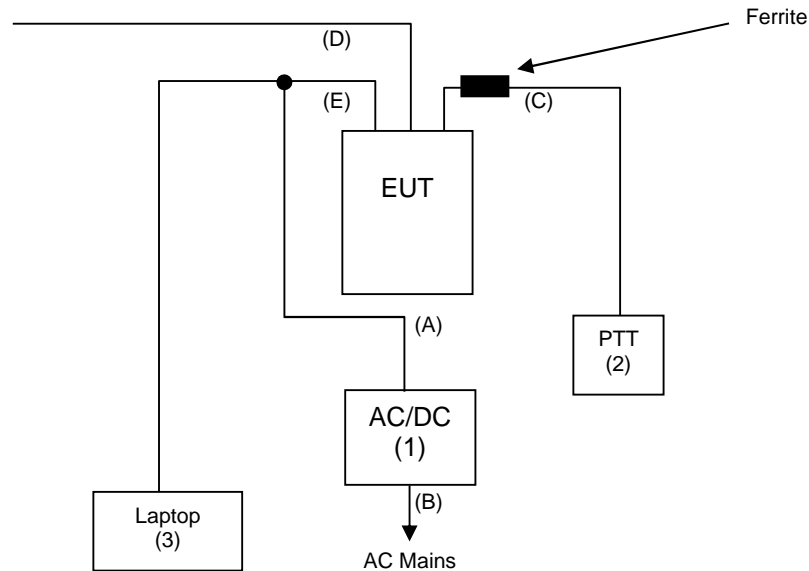

Figure 6-1: Test Setup Block Diagram

7 SUMMARY OF TESTS

Along with the tabular data shown below, plots were taken of all signals deemed important enough to document.

7.1 26dB Bandwidth and Emission Mask – §2.1049 / §90.210(m)

7.1.1 Measurement Procedure

The 26dB bandwidth was measured in accordance with Subclause 5.4.3 of ANSI C63.26. The resolution bandwidth was set from 1% to 5% of the occupied bandwidth and the video bandwidth set to at least 3 times the resolution bandwidth. The trace was set to max hold with a peak detector active. The ndB down function of the spectrum analyzer was utilized to determine the 26 dB bandwidth of the emission.

To show compliance with the emission mask requirements defined in Section 90.210(m), the measurement guidance in KDB 971168 D01 Power Meas License Digital Systems v03r01, Section 6.1. The spectrum analyzer span was set to 150% of the signal bandwidth and the resolution bandwidth was set to a minimum of 1% of the occupied bandwidth. An average detector was applied using a single sweep with the sweep time set to 1ms per sweep point. The resulting trace was compared to the Mask M requirements.

7.1.2 Measurement Results

Performed by: Jeremy Pickens

Table 7.1.2-1: 26dB Bandwidth

Modulation	Frequency (MHz)	26dB Bandwidth (MHz)
OFDM	4945	9.791
	4965	9.839
	4985	9.794

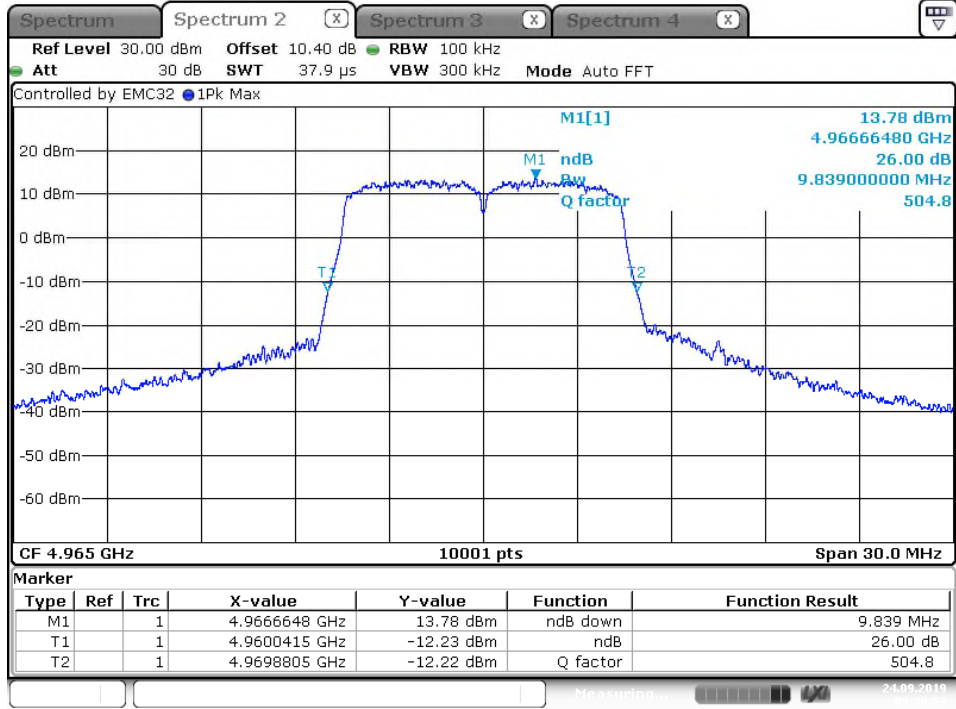

Date: 24.SEP.2019 09:36:59

Figure 7.1.2-1: Sample Plot - 26dB BW

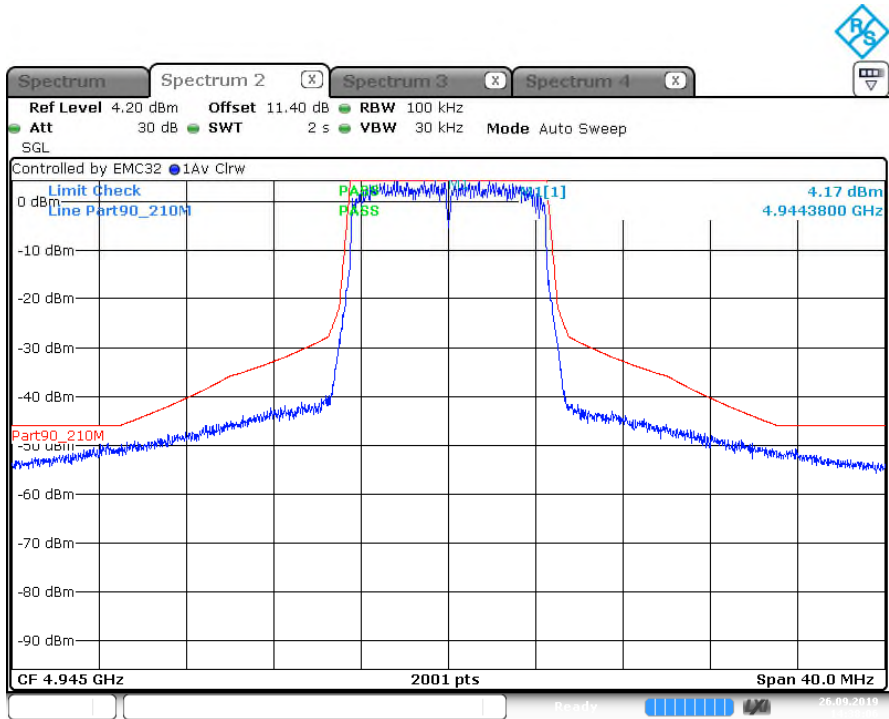

Date: 26.SEP.2019 14:38:05

Figure 7.1.2-2: Mask M – Low Channel

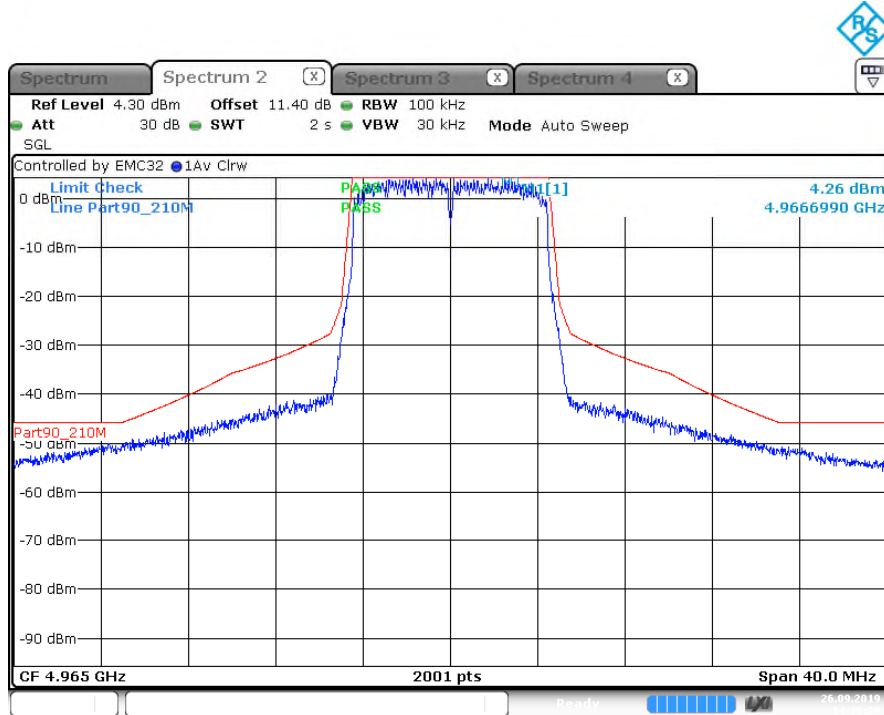

Figure 7.1.2-3: Mask M – Middle Channel

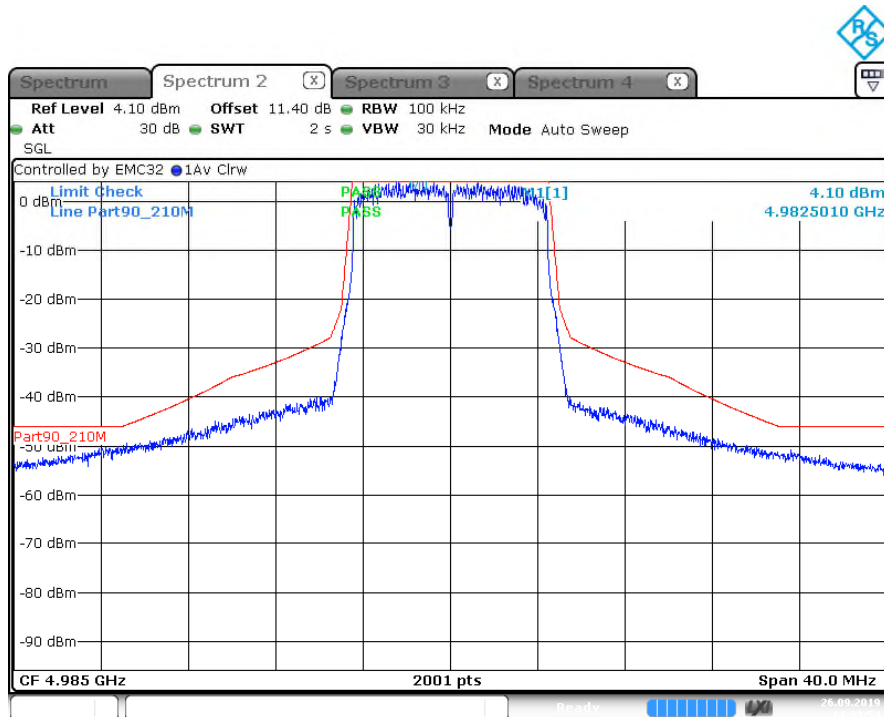

Figure 7.1.2-4: Mask M – High Channel

7.2 Fundamental Emission Output Power – §90.1215(a)(1)

7.2.1 Measurement Procedure

The average conducted output power was measured in accordance with FCC KDB 971168 D01, Section 5.2 utilizing an average power meter followed by duty-cycle correction (if required).

For a 10MHz nominal channel bandwidth operating in the 4940-4990MHz band, the limit is 30dBm.

7.2.2 Measurement Results

Performed by: Jeremy Pickens

Table 7.2.2-1: Conducted Output Power

Modulation	Frequency (MHz)	Port 1 Avg Pwr (dBm)	Port 2 Avg Pwr (dBm)	Port 3 Avg Pwr (dBm)	Port 4 Avg Pwr (dBm)	Total Average Power (dBm)
OFDM	4945	23.3	23.7	23.8	23.3	29.6
	4965	23.4	24.1	23.8	23.5	29.7
	4985	23.5	23.9	23.5	23.6	29.6

Measured Duty Cycle: 98.2% (No correction applied)

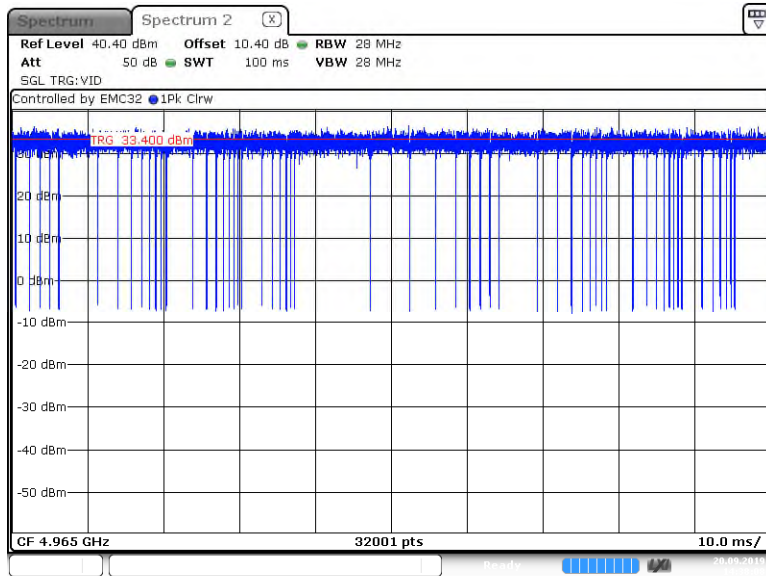

Date: 20 SEP 2019 14:38:09

*Note: Trace data was analyzed using an excel program which found the on time to be 98.2ms and off time to be 1.8ms over the course of the 100ms sweep

Figure 7.2.2-1: Duty Cycle Plot

7.3 Power Spectral Density (PSD) – §90.1215(a)(2)

7.3.1 Measurement Procedure

The Average Power Spectral Density was measured in accordance with FCC KDB 971168 D01, Section 5.4 which references Subclause 5.2.4.5 of ANSI C63.26.

The limit for PSD is 21dBm/MHz

7.3.2 Measurement Results

Performed by: Jeremy Pickens

Table 7.3.2-1: Power Spectral Density

Modulation	Frequency (MHz)	Port 1 PSD (dBm)	Port 2 PSD (dBm)	Port 3 PSD (dBm)	Port 4 PSD (dBm)	Total Average PSD (dBm)
OFDM	4945	14.39	14.80	14.64	14.27	20.55
	4965	14.45	14.98	14.58	14.41	20.63
	4985	14.58	14.75	14.31	14.38	20.53

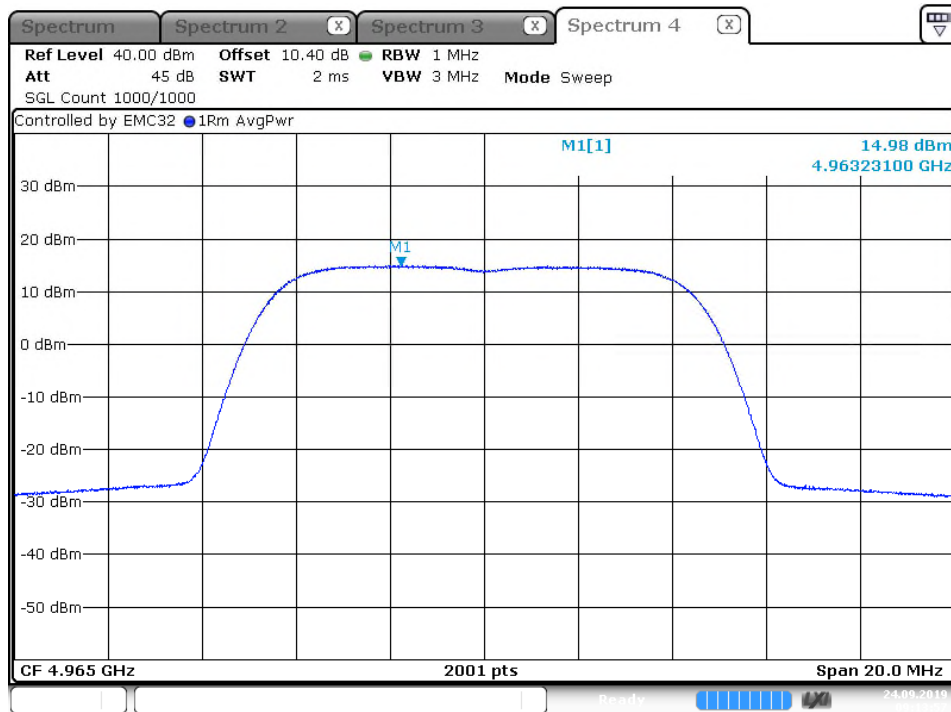

Date: 24 SEP.2019 09:13:57

Figure 7.3.2-1: Sample PSD Plot

7.4 Peak Excursion – §90.1215(e)

7.4.1 Measurement Procedure

The Peak-to-Average Power Ratio (PAPR) was measured in accordance with FCC KDB 971168 D01, Section 5.7 which references Subclause 5.2.3.4 of ANSI C63.26 for applying the CCDF function of the spectrum analyzer.

The limit for PAPR is 13dB

7.4.2 Measurement Results

Performed by: Jeremy Pickens

Table 7.4.2-1: Peak-to Average Ratio (Peak Excursion)

Modulation	Frequency (MHz)	Resolution Bandwidth (MHz)	AQT (ms)	Peak Excursion (dB)	Limit (dB)	Margin (dB)
OFDM	4965	10	1	8.35	13	4.65

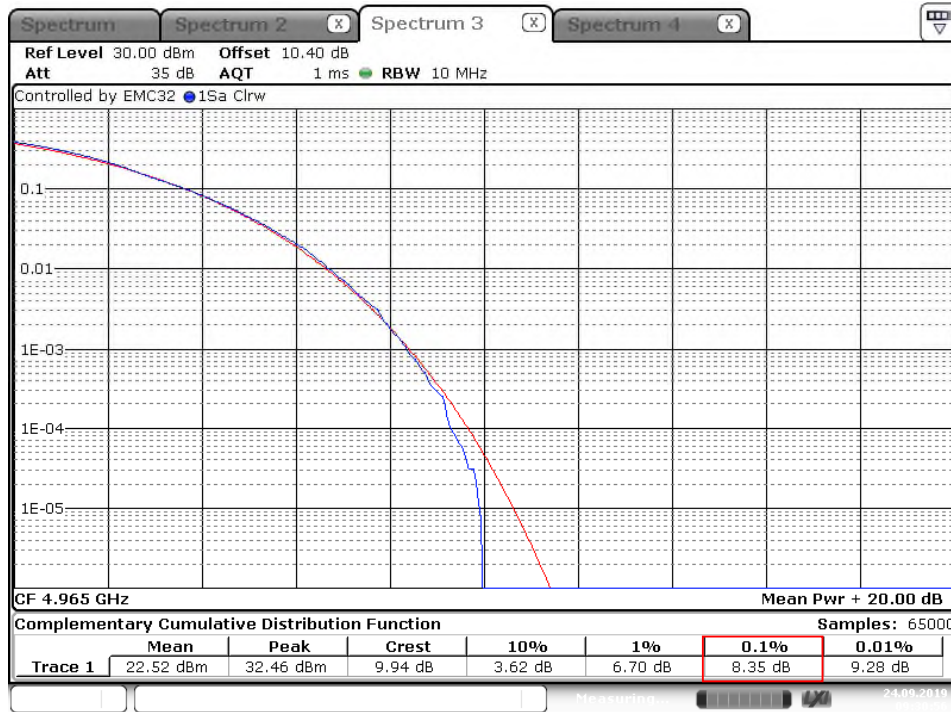

Date: 24 SEP 2019 09:30:56

Figure 7.4.2-1: PAPR Plot

7.5 Maximum Permissible Exposure – §90.1217 / §1.1310

7.5.1 Measurement Procedure

Maximum permissible exposure conditions were calculated using the total average power and antenna gains.

The limit for Occupational/Controlled Exposure 5 mW/cm²
 The limit for General Population/Uncontrolled Exposure is 1mW/cm²

7.5.2 Results

Performed by: Jeremy Pickens

The Power Density (mW/cm²) is calculated as follows:

$$S = \frac{PG}{4\pi R^2}$$

Where:

S = power density (in appropriate units, e.g. mW/cm²)

P = power input to the antenna (in appropriate units, e.g., mW)

G = power gain of the antenna in the direction of interest relative to an isotropic radiator

R = distance to the center of radiation of the antenna (appropriate units, e.g., cm)

Table 7.5.2-1: MPE Calculation

Transmit Frequency (MHz)	Radio Power (dBm)	Power Density Limit (mW/cm ²)	Radio Power (mW)	Antenna Gain (dBi)	Antenna Gain (mW eq.)	Distance (cm)	Power Density (mW/cm ²)
4945	30	1.00	1000.00	8.52	7.112	24	0.983

Note: MIMO directional antenna gain was calculated from the equation in KDB 662911 D01:
 Directional gain = G_{ANT} + 10 log(N_{ANT}) dBi

7.6 Antenna Port Conducted Spurious Emissions - §90.210(m) / §2.1051

7.6.1 Measurement Procedure

The unwanted emissions at the antenna port were measured in accordance with FCC KDB 971168 D01, Section 6 and Subclause 5.7 of ANSI C63.26.

Limit from §90.210(m): On any frequency removed from the assigned frequency between above 150% of the authorized bandwidth: 50 dB or $55 + 10 \log(P)$ dB, whichever is the lesser attenuation.

Above 1GHz, a resolution bandwidth of 500kHz was used in lieu of 1MHz to provide the dynamic range between the fundamental emission and the noise floor.

7.6.2 Measurement Results

Performed by: Jeremy Pickens

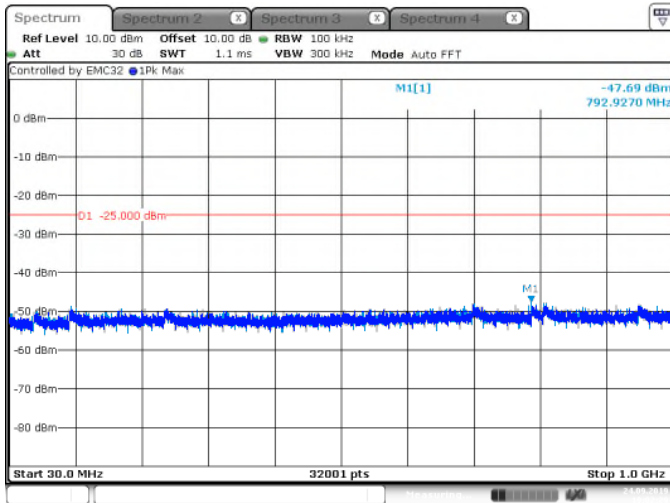

Date: 24 SEP 2019 10:02:30

Figure 7.6.2-1: LCH – 30MHz–1GHz

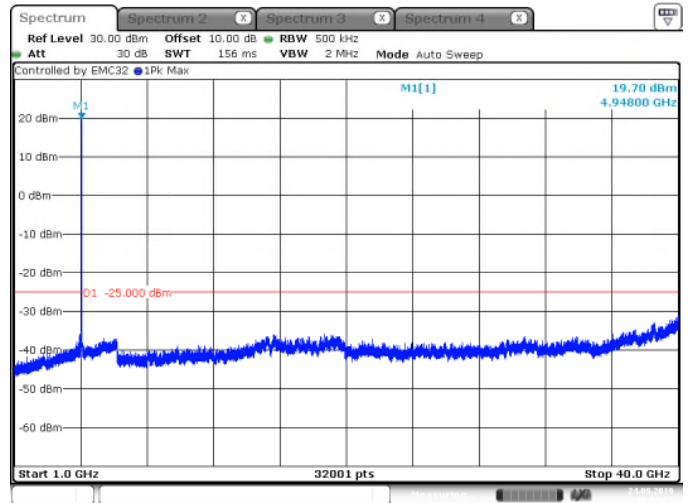

Date: 24 SEP 2019 09:53:22

Figure 7.6.2-2: LCH – 1GHz–40GHz

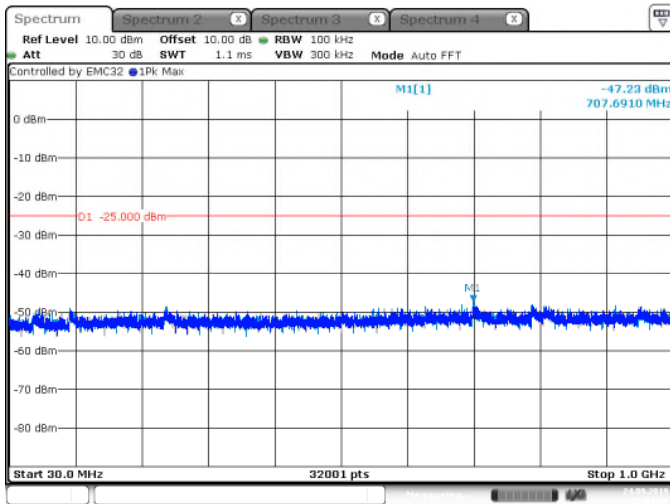

Date: 24 SEP 2019 10:04:28

Figure 7.6.2-3: MCH – 30MHz–1GHz

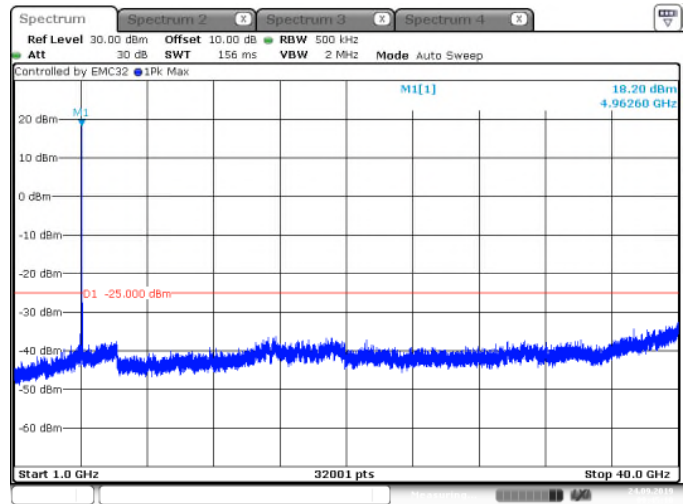

Date: 24 SEP 2019 09:45:10

Figure 7.6.2-4: MCH – 1GHz–40GHz

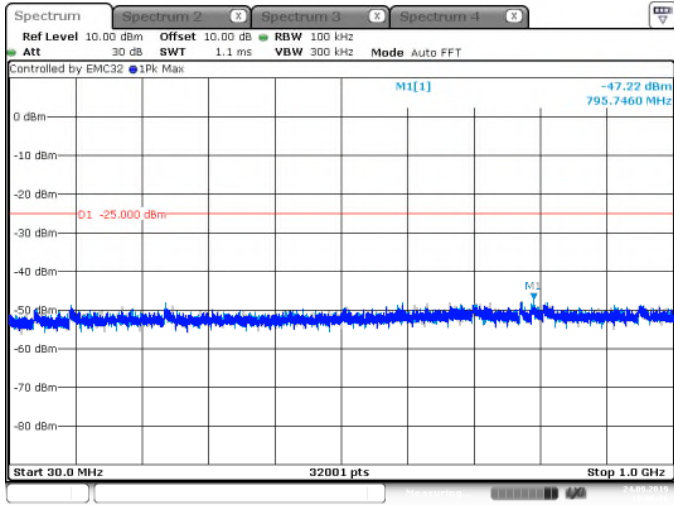

Date: 24 SEP 2019 10:08:27

Figure 7.6.2-5: HCH – 30MHz–1GHz

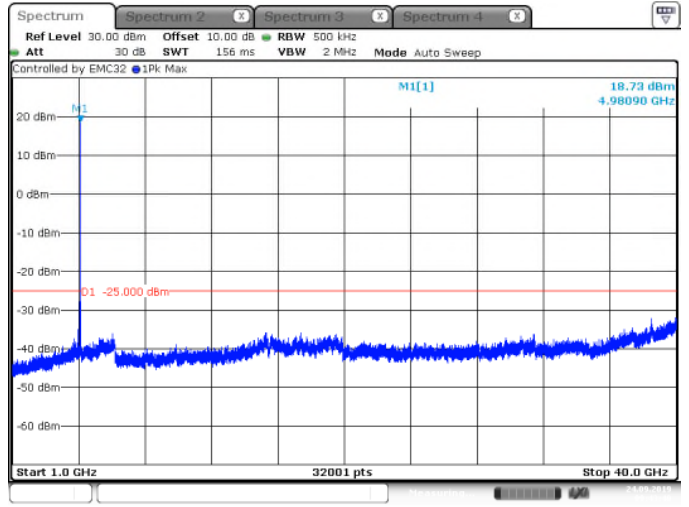

Date: 24 SEP 2019 09:43:39

Figure 7.6.2-6: HCH – 1GHz–40GHz

7.7 Radiated Spurious Emissions / Cabinet Radiation - §90.210(m)

7.7.1 Measurement Procedure

The unwanted emissions were measured radiated over the frequency range of 30MHz to 40GHz.

The EUT was rotated through 360° and the receive antenna height was varied from 1 meter to 4 meters so that the maximum radiated emissions level would be detected. For frequencies below 1000 MHz, quasi-peak measurements were made using a resolution bandwidth RBW of 120 kHz and a video bandwidth VBW of 300 kHz. For frequencies above 1000 MHz, peak and average measurements were made with RBW and VBW of 1 MHz and 3 MHz respectively.

Cabinet radiation measurements were recorded with the antenna ports terminated into 50-Ohms through attenuators.

Limit from §90.210(m): On any frequency removed from the assigned frequency between above 150% of the authorized bandwidth: 50 dB or 55 + 10 log (P) dB, whichever is the lesser attenuation. The device was configured for 24dBm output power per port, so the applied limit was -25dBm or 70.2dBµV/m at 3 meters. (55+10log(0.25)=-6; 55-6=49; 24-49=-25)

7.7.2 Measurement Results

Performed by: Jeremy Pickens

Table 7.7.2-1: Radiated Spurious Emissions Tabulated Data

Frequency (MHz)	Level (dBµV)		Antenna Polarity (H/V)	Correction Factors (dB)	Corrected Level (dBµV/m)		Limit (dBµV/m)		Margin (dB)	
	pk	RMS			pk	RMS	pk	RMS	pk	RMS
Low Channel - 4945MHz										
9890	46.5	33.1	H	15.61	--	48.71	--	70.2	--	21.5
9890	45.9	33.1	V	15.61	--	48.71	--	70.2	--	21.5
Mid Channel - 4965MHz										
9930	46.3	33.1	H	15.65	--	48.75	--	70.2	--	21.4
9930	46.8	33.1	V	15.65	--	48.75	--	70.2	--	21.4
High Channel - 4985MHz										
9970	45.8	33	H	15.69	--	48.69	--	70.2	--	21.5
9970	45.8	33	V	15.69	--	48.69	--	70.2	--	21.5

7.7.3 Sample Calculation:

$$R_C = R_U + CF_T$$

Where:

- CF_T = Total Correction Factor (AF+CA+AG)-DC (Average Measurements Only)
- R_U = Uncorrected Reading
- R_C = Corrected Level
- AF = Antenna Factor
- CA = Cable Attenuation
- AG = Amplifier Gain
- DC = Duty Cycle Correction Factor

Example Calculation: RMS

Corrected Level: $33.1 + 15.65 - 0 = 48.75\text{dB}\mu\text{V}$

Margin: $70.2\text{dB}\mu\text{V} - 48.75\text{dB}\mu\text{V} = 21.4\text{dB}$

7.8 Frequency Stability - §90.213(a) / §2.1055**7.8.1 Measurement Procedure**

The frequency stability at the antenna port were measured in accordance with FCC KDB 971168 D01, Section 9 and Subclause 5.6 of ANSI C63.26.

7.8.2 Measurement Results

Performed by: Jeremy Pickens

Table 7.8.2-1: Frequency Stability Tabulated Data

Nominal Voltage		10.8Vdc	Nominal Frequency (MHz)		4965
Voltage (VDC)	Temperature (°C)	Frequency Low (MHz)	Frequency High (MHz)	Frequency Center (MHz)	Deviation (ppm)
10.8	-30	4960.3689	4969.5991	4964.984	-3.22
	-20	4960.3329	4969.6311	4964.982	-3.63
	-10	4960.3889	4969.5831	4964.986	-2.82
	0	4960.3929	4969.5951	4964.994	-1.21
	+10	4960.3969	4969.5871	4964.992	-1.61
	+20	4960.4049	4969.5871	4964.996	-0.81
	+30	4960.4049	4969.5911	4964.998	-0.4
	+40	4960.4089	4969.5831	4964.996	-0.81
	+50	4960.4009	4969.5911	4964.996	-0.81
9.18	+20	4960.4049	4969.5871	4964.996	-0.81
12.42	+20	4960.4049	4969.5911	4964.998	-0.4

8 ESTIMATION OF MEASUREMENT UNCERTAINTY

The expanded laboratory measurement uncertainty figures (U_{Lab}) provided below correspond to an expansion factor (coverage factor) $k = 1.96$ which provide confidence levels of 95%.

Table 8-1: Estimation of Measurement Uncertainty

Parameter	U_{lab}
Occupied Channel Bandwidth	$\pm 0.009 \%$
RF Conducted Output Power	$\pm 0.349 \text{ dB}$
Power Spectral Density	$\pm 0.372 \text{ dB}$
Antenna Port Conducted Emissions	$\pm 1.264 \text{ dB}$
Radiated Emissions $\leq 1 \text{ GHz}$	$\pm 5.814 \text{ dB}$
Radiated Emissions $> 1 \text{ GHz}$	$\pm 4.318 \text{ dB}$
Temperature	$\pm 0.860 \text{ }^\circ\text{C}$
Radio Frequency	$\pm 2.832 \times 10^{-8}$
AC Power Line Conducted Emissions	$\pm 3.360 \text{ dB}$

9 CONCLUSION

In the opinion of TUV SUD the SC4480E-235470-SBST, manufactured by Silvus Technologies, Inc. meets the requirements of FCC Part 15 subpart C and ISED Canada's Radio Standards Specification RSS-247 for the tests documented herein.

Appendix A: Plots

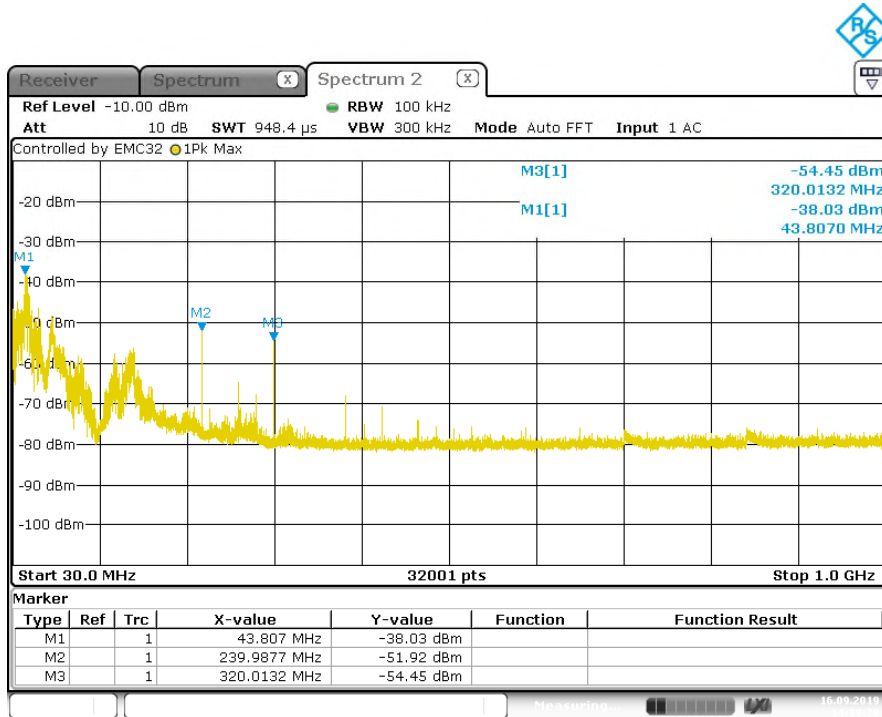

Note: Emissions above the noise floor are from the digital sections of the DUT and not associated with the radio.
Figure A-1: 30MHz-1GHz

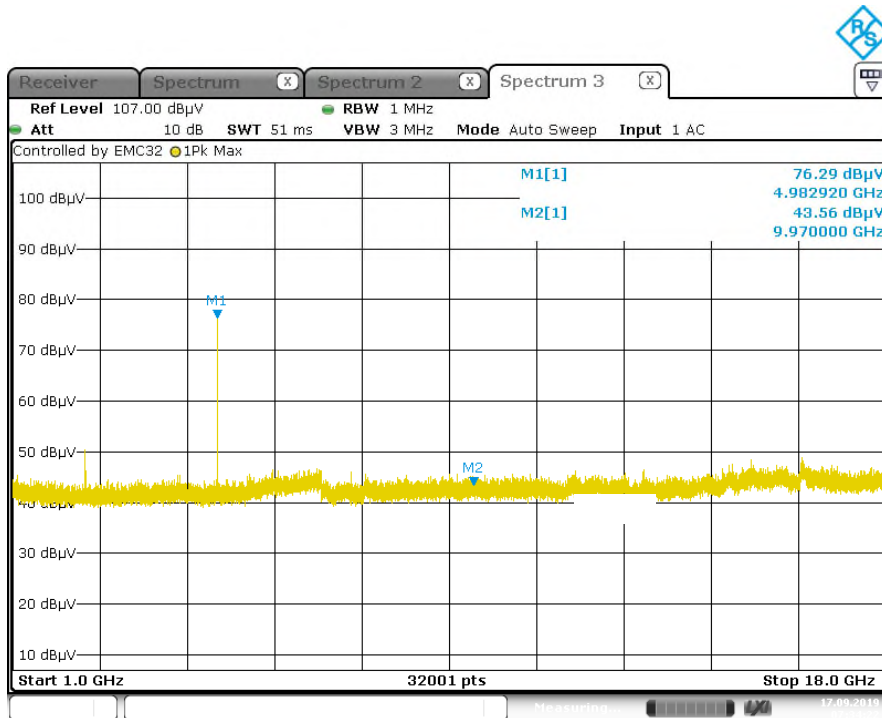
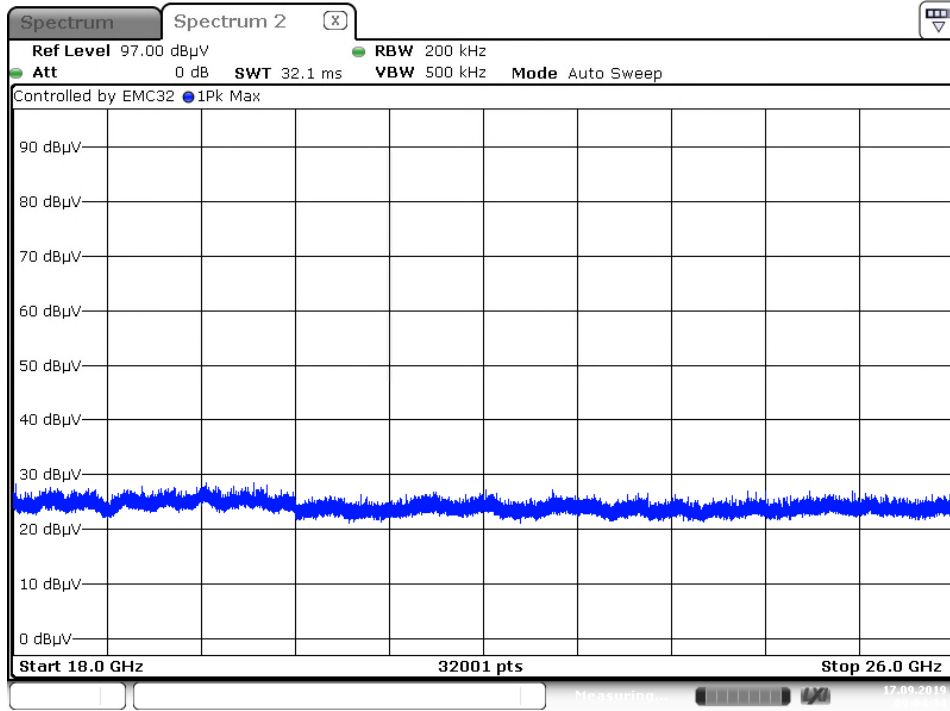
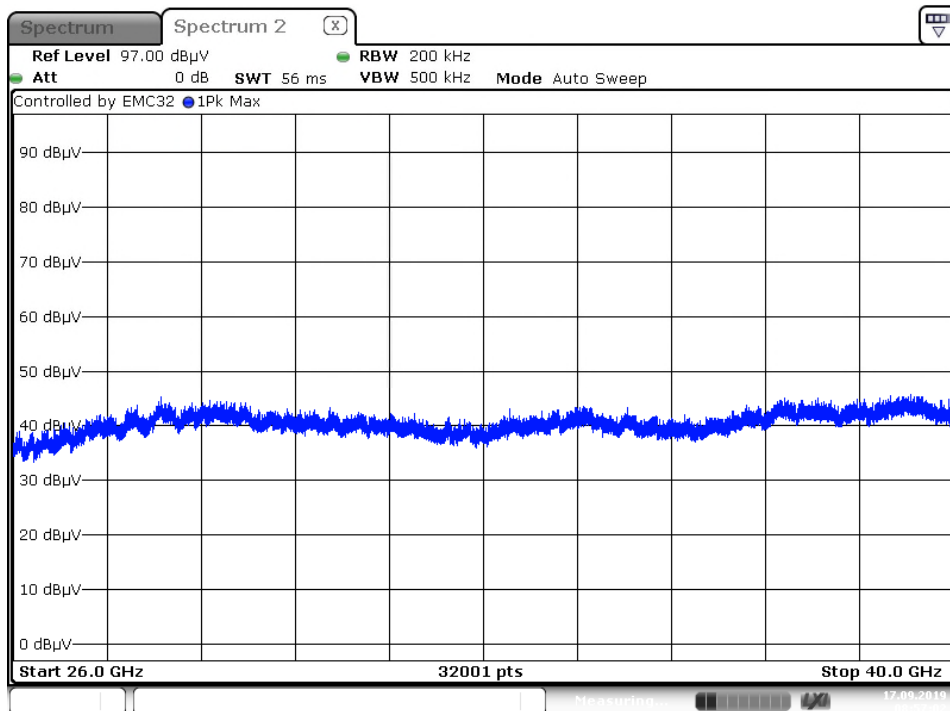

Figure A-2: 1GHz-18GHz



Date: 17.SEP.2019 09:04:33

Figure A-3: 18GHz-26GHz



Date: 17.SEP.2019 08:57:03

Figure A-4: 26GHz-40GHz

END REPORT