

The University of Michigan
Radiation Laboratory
3228 EECS Building
Ann Arbor, MI 48109-2122
Tel: (734) 764-0500

Measured Radio Frequency Emissions
From

Hyperlink Technologies Inc
Model: MYF-WL-2401

Report No. 139
October 4, 2002

Copyright © 2002

For:
Hyperlink Technologies Inc
1200 Clint Moore Road, Suite 14
Boca Raton, Florida 33487

Contact:
Peter Roth
Tel: (561) 995-2256
Fax: (561) 995-2432
PO: Verbal

Measurements made by:

Joseph D Brunett

Tests supervised by:
Report approved by:

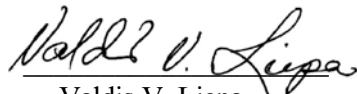
Valdis V. Liepa
Research Scientist

Summary

Tests for compliance with FCC Regulations, Part 15.247, and with Industry Canada Regulations, RSS-210, Section 6.2.2 (o), were performed on HyperLink spread spectrum RF Extended Range LAN System. The DUT is subject to the Rules and Regulations as a transmitter and a digital device. This link uses an FCC certified spread spectrum Lucent radio, but adds cables, amplifiers, and external antennas. Here we report on the results of measurements for combinations of antennas and amplifiers.

In testing completed 25-Sep-02, the worst radiated emissions in restricted bands were met by 0.9 dB at a frequency of 2390 MHz (see pp. 11-K).

1. Introduction

HyperLink/Lucent Extended Range Radio, Model MYF-WL-2401, was tested for compliance with FCC Regulations, Part 15, adopted under Docket 87-389, April 18, 1989, and with Industry Canada RSS-210, Issue 5, Draft 1, Section 6.2.2 (t1). The tests were performed at the University of Michigan Radiation Laboratory Willow Run Test Range following the procedures described in ANSI C63.4-1992 "Methods of Measurement of Radio-Noise Emissions from Low-Voltage Electrical and Electronic Equipment in the Range of 9 kHz to 40 GHz". The Site description and attenuation characteristics of the Open Site facility are on file with FCC Laboratory, Columbia, Maryland (FCC Reg. No: 91050) and with Industry Canada, Ottawa, ON (File Ref. No: IC 2057).

2. Test Procedure and Equipment Used

The test equipment commonly used in our facility is listed in Table 2.1 below. The HP 8593A spectrum analyzer is used for primary amplitude and frequency reference.

Table 2.1 Test Equipment

Test Instrument	Eqpt. Used	Manufacturer/Model
Spectrum Analyzer (0.1-1500 MHz)		Hewlett-Packard, 182T/8558B
Spectrum Analyzer (9kHz-22GHz)	X	Hewlett-Packard 8593A SN: 3107A01358
Spectrum Analyzer (9kHz-26GHz)	X	Hewlett-Packard 8593E, SN: 3412A01131
Spectrum Analyzer (9kHz-26GHz)		Hewlett-Packard 8563E, SN: 3310A01174
Spectrum Analyzer (9kHz-40GHz)		Hewlett-Packard 8564E, SN: 3745A01031
Power Meter	X	Hewlett-Packard, 432A
Power Meter		Anritsu, ML4803A/MP
Peak Power Meter	X	Pacific Instruments 1018B
Harmonic Mixer (26-40 GHz)		Hewlett-Packard 11970A, SN: 3003A08327
Harmonic Mixer (40-60 GHz)		Hewlett-Packard 11970U, SN: 2332A00500
Harmonic Mixer (75-110 GHz)		Hewlett-Packard 11970W, SN: 2521A00179
Harmonic Mixer (140-220 GHz)		Pacific Millimeter Prod., GMA, SN: 26
S-Band Std. Gain Horn	X	S/A, Model SGH-2.6
C-Band Std. Gain Horn	X	University of Michigan, NRL design
XN-Band Std. Gain Horn	X	University of Michigan, NRL design
X-Band Std. Gain Horn	X	S/A, Model 12-8.2
X-band horn (8.2- 12.4 GHz)	X	Narda 640
X-band horn (8.2- 12.4 GHz)		Scientific Atlanta , 12-8.2, SN: 730
K-band horn (18-26.5 GHz)	X	FXR, Inc., K638KF
Ka-band horn (26.5-40 GHz)	X	FXR, Inc., U638A
U-band horn (40-60 GHz)		Custom Microwave, HO19
W-band horn(75-110 GHz)		Custom Microwave, HO10
G-band horn (140-220 GHz)		Custom Microwave, HO5R
Bicone Antenna (30-250 MHz)	X	University of Michigan, RLBC-1
Bicone Antenna (200-1000 MHz)	X	University of Michigan, RLBC-2
Dipole Antenna Set (30-1000 MHz)	X	University of Michigan, RLDP-1,-2,-3
Dipole Antenna Set (30-1000 MHz)		EMCO 2131C, SN: 992
Active Rod Antenna (30 Hz-50 MHz)		EMCO 3301B, SN: 3223
Active Loop Antenna (30 Hz-50 MHz)		EMCO 6502, SN:2855
Ridge-horn Antenna (300-5000 MHz)	X	University of Michigan
Amplifier (5-1000 MHz)	X	Avantak, A11-1, A25-1S
Amplifier (5-4500 MHz)	X	Avantak
Amplifier (4.5-13 GHz)	X	Avantek, AFT-12665
Amplifier (6-16 GHz)	X	Trek
Amplifier (16-26 GHz)	X	Avantek
LISN Box		University of Michigan
Signal Generator		Hewlett-Packard 8657B

3. Configuration and Identification of Device Under Test

The DUT is a spread spectrum RF wireless link operating in 2400 - 2483.5 MHz band. The system tested consisted of a laptop computer, Lucent radio, coax cable, (choice of) amplifier, (choice of) band-pass filter, and (choice of) an antenna. The system has been designed to operate with up to 12 channels from 2412 to 2462 MHz.; however, depending on the choice of components used (amplifier, filter, antenna), channels are restricted so as to meet the FCC and IC emissions limits.

The DUT was designed and manufactured by Hyperlink Technologies Inc, 1200 Clint Moore Road, Suite 14, Boca Raton, Florida 33487. Figure 3.1 shows the block diagram of the basic system. It is identified as:

Hyperlink Technologies Inc.
 Model: MYF-WL-2401
 FCC ID: MYF-WL-2401
 IC: 2837A-WL-2401

14 configurations were tested for radiated emissions compliance. It is the intent of this test report to demonstrate compliance for the full set of configurations listed in the *System Conf. Information* exhibit included in this filing.

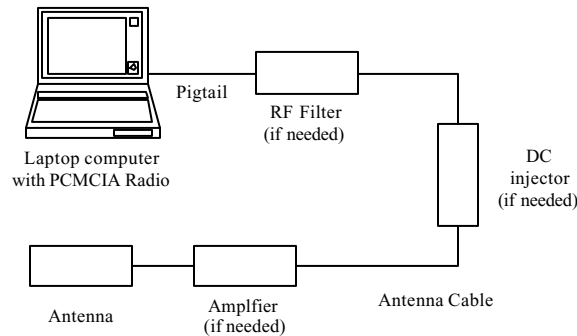

Figure 3.1 Basic block diagram of the system

With components evaluated:

Wireless Radio

Lucent Radio
 Model Orinoco Gold

SN: 01UT33373491
 FCC ID: IMRWLPCEL4H
 CAN: 230391152A

Laptop Computer

IBM Thinkpad 710C

SN: 23-RYY74
 FCC ID: ANO263OCS

Amplifier(s)

Table 3.1 Amplifiers

Amplifier Model	Output Power (dBm)	Used in Testing
HA2401-AGC-250	24.0	X
HA2401-AGC500	27.0	
HA2401-AGC1000	30.0	X

Power Supply, for amplifier(s)

Sunfone

Model: ACSM-26 (certified under FCC ID: MYFWL2401) FCC Class A

Model: ACSD-05 (certified under FCC ID: MYFWL2401) FCC Class B

DC Injector

HyperLink

SN: none

Filters

Bandpass Filter, 4-pole, Model: FLT-2437-20-4(BLK)

Cables

Antenna cable, 50-150 feet, WBC400, with N-connectors - 3dB/50ft loss at 2.437 GHz

Pigtail cable, 12 in., RG-58, HyperLink

Antennas

Table 3.2 Antennas

Antenna Model	Construction	Gain (dBi)	Used in Testing
HG2401U	whip/monopole	1	X
HG2405U	whip/monopole	5	X
HG2406U	whip/monopole	6	
HG2407U	whip/monopole	7	
HG2408U	whip/monopole	8	
HG2409U	whip/monopole	9	
HG2410U	whip/monopole	10	
HG2412U	whip/monopole	12	
HG2415U	whip/monopole	15	X
HG2403MU	whip/automotive	3	X
HG2405MU	whip/automotive	5	X
HG2408P	patch	8	X
HG2409P	patch	9	
HG2413P	patch	13	
HG2414P	patch	14	
HG2416P	patch	16	
HG-UNI-16	patch	16	
HG2412P	linear array	12	X
HG2415P	linear array	15	
HG2417P	linear array	17	
HG2420P	linear array	20	X
HG2412Y	Yagi-Uda	12	X
HG2415Y	Yagi-Uda	15	X
HG2414D	parabolic dish	14	X
HG2415G	dish	15	X
HG2419G	dish	19	
HG2421G	dish	21	
HG2424G	dish	24	X

3.1 EMI Relevant Modifications

During the course of testing, amplifier (if included), filter (if included), and antenna were selected and then the available channels for the particular configuration were reduced (if necessary) to meet the band-edge and harmonic emission limits.

4. Emission Limits

4.1 Radiated Emission Limits

Since the DUT is a spread spectrum device (15.247, 2.4 GHz), the radiated emissions are subject to emissions in restricted bands only (15.205). The applicable frequencies, through ten harmonics, are given below in Table 4.1. Emission limits from digital circuitry are specified in Table 4.2.

Table 4.1 Radiated Emission Limits (FCC:15.205; IC:RSS-210, 6.3) - Transmitter

Frequency (MHz)	Fundamental Ave. E _{lim} (3m)		Spurious* Ave. E _{lim} (3m)	
	(μ V/m)	dB (μ V/m)	(μ V/m)	dB (μ V/m)
2400-2483.5	---		---	
2310-2390 2483.5-2500 4500-5250	Restricted Bands Bands		500	54.0
7250-7750 14470-14500 17700-21400 22010-23120 23600-24000	Restricted Bands		500	54.0

* Measure up to tenth harmonic; 1 MHz res. BW, 100 Hz video BW (for average detection)

Table 4.2 Radiated Emission Limits (FCC:15.109;IC: RSS-210, 7.3) - Digital device.

Frequency (MHz)	Class A ds = 10 m		Class B ds = 3 m	
	(μ V/m)	dB (μ V/m)	(μ V/m)	dB (μ V/m)
30-88	90	39.0	100	40.0
88-216	150	43.5	150	43.5
219-960	210	46.4	200	46.0
960-	300	49.5	500	54.0

120 kHz BW up to 1 GHz, 1 MHz BW above 1 GHz

4.2 Conducted Emission Limits

Table 4.3 Conducted Emission Limits (FCC:15.107; IC: RSS-210, 6.6).

Frequency (MHz)	Class A		Class B	
	μV	$\text{dB}\mu\text{V}$	μV	$\text{dB}\mu\text{V}$
0.45-1.705	1000	60.0	250	48.0
1.705-30.0	3000	69.6	250	48.0

Note: Quasi-Peak readings apply here (9 kHz BW)

5. Radiated Emission Tests and Results

5.1 Anechoic Chamber Measurements

In our chamber, there is a set-up similar to that of an outdoor 3-meter site, with a turntable, an antenna mast, and a ground plane. Instrumentation includes spectrum analyzers and other equipment as needed. For these tests the receiver (horn) antennas were placed on a Styrofoam block, at about 1.2 m height, and the DUT on a turntable at 3 meter distance (moved to 1 m distance if needed).

Standard gain horn antennas were used for the measurements. Up to 7 GHz the horns were connected to a spectrum analyzer via RG-214 coaxial cable, and above 7 GHz a pre-amp was added. The cables and the pre-amplifier used were specially calibrated for these tests using a network analyzer.

The DUT antenna was rotated in all possible ways and the maximum emission recorded. A photograph in the *Test Setup Photos* exhibit demonstrates the measurement set-up.

5.2 Outdoor Measurements

None made

5.3 Computations and Results

To convert the dBm measured on the spectrum analyzer to dB(μ V/m), we use expression

$$E_3(\text{dB}\mu\text{V/m}) = 107 + P_R + K_A - K_G + K_E$$

where P_R = power recorded on spectrum analyzer, dB, measured at 3m
 K_A = antenna factor, dB/m
 K_G = pre-amplifier gain, including cable loss, dB
 K_E = pulse operation correction factor, dB

When presenting the data, the dominant measured emissions at each frequency, under all of the possible orientations, are given. Computations and results are given in Tables 5.1 through 5.14. There we see that in the worst case the DUT meets the limit by 0.9 dB at 2390 MHz in Table 5.11. Digital Radiated Emissions were more than 20 dB below the Class B limit. Note, that besides the emission measurements, each table contains the frequency range of operation (in upper section of the table).

Note: The radiated emissions measurements for a given amplifier/radio configuration are performed with 150 ft (10 dB) of cable in the system, i.e. minimum input power to the amplifier. As seen from the *Block Diagram* exhibit, the AGC circuitry in this amplifier provides attenuation at the input to the amplifier stage, and thus the amplifier is operating with its highest gain when the minimum input power is provided to the amplifier.

5.4 Duty Factor for Normal Operation

No Duty Factor was used during testing of this device, as it was programmed to transmit continuous.

6. Other Measurements and Computations

6.1 Peak-to-Average Ratio (15.35(b))

For the measurements presented here for emissions in restricted bands, the DUT was programmed to transmit continuous, and such was verified with spectrum analyzer set to zero-span mode. See Figure 6.1. Average measurements were made using 1 MHz RBW and 100 Hz VBW and peak measurements were made using 1 MHz RBW and 3 MHz VBW (not reported).

Typically the difference between peak and average was 12 to 13 dB, and never exceeded the 20 dB limit.

6.2 Potential Health Hazard EM Radiation Level

The following table summarizes the minimum separation distance as calculated following FCC OET Bulletin 65. Because of the large variation in antenna and amplifier configurations, minimum separation distance is calculated over the full range of total EIRP only.

To obtain the minimum separation distance for a particular system, the antenna gain (dBm) listed in Table 3.2 must be added to the amplifier output power (dBm) listed in Table 3.1, resulting in the total EIRP for a given system. If no amplifier is used, the output power of the radio from Table 6.2 is to be used in place of the amplifier output power. Cross referencing this EIRP (dBm) with that listed below will give the corresponding minimum separation distance for the given system.

Table 6.1 Potential Health Hazard Radiation Level

EIRP(dBm)	R (cm)	EIRP(dBm)	R (cm)	EIRP(dBm)	R (cm)
54	141.4	36	17.8	18	2.2
53	126.0	35	15.9	17	2.0
52	112.3	34	14.1	16	1.8
51	100.1	33	12.6	15	1.6
50	89.2	32	11.2	14	1.4
49	79.5	31	10.0	13	1.3
48	70.9	30	8.9	12	1.1
47	63.2	29	8.0	11	1.0
46	56.3	28	7.1	10	0.9
45	50.2	27	6.3	9	0.8
44	44.7	26	5.6	8	0.7
43	39.8	25	5.0	7	0.6
42	35.5	24	4.5	6	0.6
41	31.7	23	4.0	5	0.5
40	28.2	22	3.6	4	0.4
39	25.1	21	3.2	3	0.4
38	22.4	20	2.8	2	0.4
37	20.0	19	2.5	1	0.3

The following equations were used in calculating the operating distance (R).

$$EIRP(mW) = P_o(mW) \cdot 10^{\frac{Gain(dB)}{10}}$$

and

$$R = \sqrt{\frac{EIRP(mW)}{4 \cdot \Pi \cdot S(mW/cm^2)}}, \quad S = 1mW/cm^2$$

6.3 Peak Output Power (15.247(b))

For this measurement, the DUT was set in a test mode for continuous data transmission, and the amplifier was attached, without additional cables, to the radio. A peak (diode detector) power meter was connected where the antenna attaches to the system. Since the DUT transmits in continuous mode, there is no adjustment needed to the readings. Table 6.2 presents the results. The peak output power limit is 30dBm.

Table 6.2 Peak and Average Output Power (Antenna Conducted)

Freq (MHz)	Peak P(dBm)	Comment
2432	29.5	HA2401-AGC1000
2437	29.6	
2442	29.7	
2412	23.7	HA2401-AGC-250
2437	23.8	
2462	24.0	
2412	10.7	RADIO ALONE
2437	10.8	
2462	11.1	

NOTE: Since these are AGC amplifiers, their compliance must be demonstrated over a range of input power levels. See *ANNEX A* for this information.

6.4 Power Line Conducted Emissions (15.270)

The amplifier, radio, and laptop conducted emissions were not measured; the Hyperlink amplifier power supplies, Lucent radio, and laptop are already compliant with FCC/IC guidelines. See the equipment list for FCC/IC identifier information.

6.5 Bandwidth (15.247(a)(2))

For this test, the DUT was put in a test mode for continuous data transmission, and the amplifier was attached, without additional cables, to the radio. The spectrum analyzer was connected where the antenna attaches to the system. The analyzer was set for RBW=VBW=100 kHz, SPAN=100 MHz. The 6-dB bandwidth was measured for lowest, middle, and highest channels that could be used in a given configuration. Plots are shown in Figures 6.2 (a),(b).

HA2401-AGC-250

<u>Frequency</u>	<u>6 dB Bandwidth</u>
2.412 GHz	10.1 MHz
2.437 GHz	10.3 MHz
2.462 GHz	10.4 MHz

HA2401-AGC1000

<u>Frequency</u>	<u>6 dB Bandwidth</u>
2.432 GHz	10.3 MHz
2.437 GHz	10.4 MHz
2.447 GHz	10.2 MHz

RADIO ALONE

<u>Frequency</u>	<u>6 dB Bandwidth</u>
2.412 GHz	10.2 MHz
2.437 GHz	10.1 MHz
2.462 GHz	10.1 MHz

NOTE: See *ANNEX A* for a demonstration of compliance over a range of input power levels.

6.6 RF Antenna Conducted Spurious Emissions (15.247(c))

For this test, the DUT was put in a test mode for continuous data transmission, and the amplifier was attached, without additional cables, to the radio. The spectrum analyzer was connected where the antenna attaches to the system. The analyzer was set for RBW=100 kHz, VBW=300 kHz, the frequency was swept from 0 to 25 GHz. See Figures 6.3(a),(b). In the plots, only the fundamental is seen, the rest is noise. In all cases, the noise is at least 35 dB below the carrier. (Limit -20.0 dB below carrier). Figures 6.4(a),(b) demonstrate band-edge compliance at lower and upper edges of the operating band.

NOTE: See *ANNEX A* for a demonstration of compliance over a range of input power levels.

6.7 Power Spectral Density and Line Spacing (15.247(d))

For this test, the DUT was put in a test mode for continuous data transmission, and the amplifier was attached, without additional cables, to the radio. The spectrum analyzer was connected where the antenna attaches to the system. The spectrum was first scanned for the maximum spectrum peaks and then at these peaks the sweep was repeated with RBW=3 kHz, VBW=300 kHz, SPAN=300 kHz, and RBW=1 kHz, VBW=300 kHz, SPAN=100 kHz. See Figures 6.5, 6.6, and 6.7. A summary of the worst case readings follows.

HA2401-AGC-250

<u>Frequency</u>	<u>Analyzer Reading</u>	<u>Line Spacing</u>
2.41103 GHz	-2.1 dBm (Limit 8.0 dBm)	4.5 kHz
2.46683 GHz	-0.6 dBm (Limit 8.0 dBm)	4.5 kHz

HA2401-AGC1000

<u>Frequency</u>	<u>Analyzer Reading</u>	<u>Line Spacing</u>
2.43061 GHz	4.2 dBm (Limit 8.0 dBm)	5.0 kHz
2.44134 GHz	5.4 dBm (Limit 8.0 dBm)	5.5 kHz

RADIO ALONE

<u>Frequency</u>	<u>Analyzer Reading</u>	<u>Line Spacing</u>
2.41283 GHz	-11.4 dBm (Limit 8.0 dBm)	4.5 kHz
2.46347 GHz	-10.6 dBm (Limit 8.0 dBm)	4.5 kHz

NOTE: See *ANNEX A* for a demonstration of compliance over a range of input power levels.

The University of Michigan
Radiation Laboratory
3228 EECS Building
Ann Arbor, Michigan 48109-2122
(734) 764-0500

Table 5.1 Highest Emissions Measured

Radiated Emissions										2401U; 250mWB	
#	Freq. MHz	Ant. Used	Ant. Pol.	Ave dBm	Ka dB/m	Kg dB	E3 dBμV/m	E3lim dBμV/m	Pass dB	Comments	
1	2412.0									Low channel	
2	2437.0									Mid channel	
3	2462.0									High channel	
4											
5	2390.0	Horn S	H/V	-59.6	21.5	26.5	42.4	54.0	11.6	Low	
6	2390.0	Horn S	H/V	-63.4	21.5	26.5	38.6	54.0	15.4	Mid	
7	2390.0	Horn S	H/V	-60.3	21.5	26.5	41.7	54.0	12.3	High	
8	2483.5	Horn S	H/V	-68.6	21.5	23.8	36.1	54.0	17.9	Low	
9	2483.5	Horn S	H/V	-68.7	21.5	23.8	36.0	54.0	18.0	Mid	
10	2483.5	Horn S	H/V	-62.3	21.5	23.8	42.4	54.0	11.6	High	
11	4824.0	Horn C	H/V	-50.9	25.5	37.0	44.6	54.0	9.4	Low	
12	4874.0	Horn C	H/V	-49.9	25.5	37.0	45.6	54.0	8.4	Mid	
13	4924.0	Horn C	H/V	-46.8	25.5	37.0	48.7	54.0	5.3	High	
14	7236.0	Horn XN	H/V	-	25.5	36.0	-	N/A	-	Low	
15	7311.0	Horn XN	H/V	-72.2	25.5	36.0	24.3	54.0	29.7	Mid, noise	
16	7386.0	Horn XN	H/V	-72.8	25.5	36.0	23.7	54.0	30.3	High, noise	
17	9648.0	Horn X	H/V	-	25.5	34.0	-	N/A	-	Low	
18	9748.0	Horn X	H/V	-	25.5	34.0	-	N/A	-	Mid	
19	9848.0	Horn X	H/V	-	25.5	34.0	-	N/A	-	High	
20	12060.0	Horn X	H/V	-72.8	25.5	34.0	25.7	54.0	28.3	Low, noise	
21	12185.0	Horn X	H/V	-72.7	25.5	34.0	25.8	54.0	28.2	Mid, noise	
22	12310.0	Horn X	H/V	-72.8	25.5	34.0	25.7	54.0	28.3	High, noise	
23	14472.0	Horn Ku	H/V	-78.8	25.5	17.3	36.4	54.0	17.6	Low, noise	
24	14622.0	Horn Ku	H/V	-	25.5	17.3	-	N/A	-	Mid	
25	14772.0	Horn Ku	H/V	-	25.5	17.3	-	N/A	-	High	
26	16884.0	Horn Ku	H/V	-	32.3	34.0	-	N/A	-	Low	
27	17059.0	Horn Ku	H/V	-	32.3	34.0	-	N/A	-	Mid	
28	17234.0	Horn Ku	H/V	-	32.3	34.0	-	N/A	-	High	
29	19296.0	Horn K	H/V	-72.0	32.3	32.0	35.3	54.0	18.7	Low, noise	
30	19496.0	Horn K	H/V	-71.5	32.3	32.0	35.8	54.0	18.2	Mid, noise	
31	19696.0	Horn K	H/V	-71.3	32.3	32.0	36.0	54.0	18.0	High, noise	
32	21708.0	Horn K	H/V	-	32.3	32.0	-	N/A	-	Low	
33	21933.0	Horn K	H/V	-	32.3	32.0	-	N/A	-	Mid	
34	22158.0	Horn K	H/V	-69.2	32.3	32.0	38.1	54.0	15.9	High, noise	
35	24120.0	Horn Ka	H/V	-	32.3	32.0	-	N/A	-	Low	
36	24370.0	Horn Ka	H/V	-	32.3	32.0	-	N/A	-	Mid	
37	24620.0	Horn Ka	H/V	-	32.3	32.0	-	N/A	-	High	
38											
39	Configuration:						* Ave: measured with 1 MHz RBW and 100 Hz VBW				
40	Pwr supp	DC Injector	Coax	Amp	Filter	Ant					
41	ACSM-26	Yes	150 ft	250mW	No	2401U					
42											

Table 5.2 Highest Emissions Measured

Radiated Emissions										2405U; 1000mWB	
#	Freq. MHz	Ant. Used	Ant. Pol.	Ave dBm	Ka dB/m	Kg dB	E3 dBμV/m	E3lim dBμV/m	Pass dB	Comments	
1	2432.0									Low channel	
2	2437.0									Mid channel	
3	2442.0									High channel	
4											
5	2390.0	Horn S	H/V	-56.2	21.5	26.5	45.8	54.0	8.2	Low	
6	2390.0	Horn S	H/V	-57.0	21.5	26.5	45.0	54.0	9.0	Mid	
7	2390.0	Horn S	H/V	-49.1	21.5	26.5	52.9	54.0	1.1	High	
8	2483.5	Horn S	H/V	-69.0	21.5	23.8	35.7	54.0	18.3	Low	
9	2483.5	Horn S	H/V	-68.1	21.5	23.8	36.6	54.0	17.4	Mid	
10	2483.5	Horn S	H/V	-64.2	21.5	23.8	40.5	54.0	13.5	High	
11	4864.0	Horn C	H/V	-46.1	25.5	37.0	49.4	54.0	4.6	Low	
12	4874.0	Horn C	H/V	-42.5	25.5	37.0	53.0	54.0	1.0	Mid	
13	4884.0	Horn C	H/V	-44.5	25.5	37.0	51.0	54.0	3.0	High	
14	7296.0	Horn XN	H/V	-69.3	25.5	36.0	27.2	54.0	26.8	Low	
15	7311.0	Horn XN	H/V	-68.7	25.5	36.0	27.8	54.0	26.2	Mid	
16	7326.0	Horn XN	H/V	-69.0	25.5	36.0	27.5	54.0	26.5	High	
17	9728.0	Horn X	H/V	-	25.5	34.0	-	N/A	-	Low	
18	9748.0	Horn X	H/V	-	25.5	34.0	-	N/A	-	Mid	
19	9768.0	Horn X	H/V	-	25.5	34.0	-	N/A	-	High	
20	12160.0	Horn X	H/V	-72.9	25.5	34.0	25.6	54.0	28.4	Low, noise	
21	12185.0	Horn X	H/V	-72.6	25.5	34.0	25.9	54.0	28.1	Mid, noise	
22	12210.0	Horn X	H/V	-72.8	25.5	34.0	25.7	54.0	28.3	High, noise	
23	14592.0	Horn Ku	H/V	-	25.5	17.3	-	N/A	-	Low	
24	14622.0	Horn Ku	H/V	-	25.5	17.3	-	N/A	-	Mid	
25	14652.0	Horn Ku	H/V	-	25.5	17.3	-	N/A	-	High	
26	17024.0	Horn Ku	H/V	-	32.3	34.0	-	N/A	-	Low	
27	17059.0	Horn Ku	H/V	-	32.3	34.0	-	N/A	-	Mid	
28	17094.0	Horn Ku	H/V	-	32.3	34.0	-	N/A	-	High	
29	19456.0	Horn K	H/V	-71.9	32.3	32.0	35.4	54.0	18.6	Low, noise	
30	19496.0	Horn K	H/V	-71.5	32.3	32.0	35.8	54.0	18.2	Mid, noise	
31	19536.0	Horn K	H/V	-71.6	32.3	32.0	35.7	54.0	18.3	High, noise	
32	21888.0	Horn K	H/V	-	32.3	32.0	-	N/A	-	Low	
33	21933.0	Horn K	H/V	-	32.3	32.0	-	N/A	-	Mid	
34	21978.0	Horn K	H/V	-69.1	32.3	32.0	38.2	N/A	-	High, noise	
35	24320.0	Horn Ka	H/V	-	32.3	32.0	-	N/A	-	Low	
36	24370.0	Horn Ka	H/V	-	32.3	32.0	-	N/A	-	Mid	
37	24420.0	Horn Ka	H/V	-	32.3	32.0	-	N/A	-	High	
38											
39	Configuration:						* Ave: measured with 1 MHz RBW and 100 Hz VBW				
40	Pwr supp	DC Injector	Coax	Amp	Filter	Ant					
41	ACSD-05	Yes	150 ft	1000 mW	No	2405U					
42											

Table 5.3 Highest Emissions Measured

Radiated Emissions										2415U; 250mWB	
#	Freq. MHz	Ant. Used	Ant. Pol.	Ave dBm	Ka dB/m	Kg dB	E3 dBμV/m	E3lim dBμV/m	Pass dB	Comments	
1	2412.0									Low channel	
2	2437.0									Mid channel	
3	2462.0									High channel	
4											
5	2390.0	Horn S	H/V	-52.5	21.5	26.5	49.5	54.0	4.5	Low	
6	2390.0	Horn S	H/V	-56.4	21.5	26.5	45.6	54.0	8.4	Mid	
7	2390.0	Horn S	H/V	-54.0	21.5	26.5	48.0	54.0	6.0	High	
8	2483.5	Horn S	H/V	-63.0	21.5	23.8	41.7	54.0	12.3	Low	
9	2483.5	Horn S	H/V	-66.9	21.5	23.8	37.8	54.0	16.2	Mid	
10	2483.5	Horn S	H/V	-60.9	21.5	23.8	43.8	54.0	10.2	High	
11	4824.0	Horn C	H/V	-47.5	25.5	37.0	48.0	54.0	6.0	Low	
12	4874.0	Horn C	H/V	-48.7	25.5	37.0	46.8	54.0	7.2	Mid	
13	4924.0	Horn C	H/V	-46.5	25.5	37.0	49.0	54.0	5.0	High	
14	7236.0	Horn XN	H/V	-	25.5	36.0	-	N/A	-	Low	
15	7311.0	Horn XN	H/V	-69.1	25.5	36.0	27.4	54.0	26.6	Mid	
16	7386.0	Horn XN	H/V	-69.3	25.5	36.0	27.2	54.0	26.8	High	
17	9648.0	Horn X	H/V	-	25.5	34.0	-	N/A	-	Low	
18	9748.0	Horn X	H/V	-	25.5	34.0	-	N/A	-	Mid	
19	9848.0	Horn X	H/V	-	25.5	34.0	-	N/A	-	High	
20	12060.0	Horn X	H/V	-72.7	25.5	34.0	25.8	54.0	28.2	Low, noise	
21	12185.0	Horn X	H/V	-72.8	25.5	34.0	25.7	54.0	28.3	Mid, noise	
22	12310.0	Horn X	H/V	-72.5	25.5	34.0	26.0	54.0	28.0	High, noise	
23	14472.0	Horn Ku	H/V	-78.7	25.5	17.3	36.5	54.0	17.5	Low, noise	
24	14622.0	Horn Ku	H/V	-	25.5	17.3	-	N/A	-	Mid	
25	14772.0	Horn Ku	H/V	-	25.5	17.3	-	N/A	-	High	
26	16884.0	Horn Ku	H/V	-	32.3	34.0	-	N/A	-	Low	
27	17059.0	Horn Ku	H/V	-	32.3	34.0	-	N/A	-	Mid	
28	17234.0	Horn Ku	H/V	-	32.3	34.0	-	N/A	-	High	
29	19296.0	Horn K	H/V	-72.1	32.3	32.0	35.2	54.0	18.8	Low, noise	
30	19496.0	Horn K	H/V	-71.8	32.3	32.0	35.5	54.0	18.5	Mid, noise	
31	19696.0	Horn K	H/V	-71.7	32.3	32.0	35.6	54.0	18.4	High, noise	
32	21708.0	Horn K	H/V	-	32.3	32.0	-	N/A	-	Low	
33	21933.0	Horn K	H/V	-	32.3	32.0	-	N/A	-	Mid	
34	22158.0	Horn K	H/V	-69.1	32.3	32.0	38.2	54.0	15.8	High, noise	
35	24120.0	Horn Ka	H/V	-	32.3	32.0	-	N/A	-	Low	
36	24370.0	Horn Ka	H/V	-	32.3	32.0	-	N/A	-	Mid	
37	24620.0	Horn Ka	H/V	-	32.3	32.0	-	N/A	-	High	
38											
39	Configuration:						* Ave: measured with 1 MHz RBW and 100 Hz VBW				
40	Pwr supp	DC Injector	Coax	Amp	Filter	Ant					
41	ACSM-26	Yes	150 ft	250mW	No	2415U					
42											

Table 5.4 Highest Emissions Measured

Radiated Emissions										2403MU; 250mWB	
#	Freq. MHz	Ant. Used	Ant. Pol.	Ave dBm	Ka dB/m	Kg dB	E3 dBμV/m	E3lim dBμV/m	Pass dB	Comments	
1	2412.0									Low channel	
2	2437.0									Mid channel	
3	2462.0									High channel	
4											
5	2390.0	Horn S	H/V	-64.9	21.5	26.5	37.1	54.0	16.9	Low	
6	2390.0	Horn S	H/V	-65.6	21.5	26.5	36.4	54.0	17.6	Mid	
7	2390.0	Horn S	H/V	-63.5	21.5	26.5	38.5	54.0	15.5	High	
8	2483.5	Horn S	H/V	-70.6	21.5	23.8	34.1	54.0	19.9	Low	
9	2483.5	Horn S	H/V	-70.7	21.5	23.8	34.0	54.0	20.0	Mid	
10	2483.5	Horn S	H/V	-68.2	21.5	23.8	36.5	54.0	17.5	High	
11	4824.0	Horn C	H/V	-58.5	25.5	37.0	37.0	54.0	17.0	Low	
12	4874.0	Horn C	H/V	-58.0	25.5	37.0	37.5	54.0	16.5	Mid	
13	4924.0	Horn C	H/V	-53.2	25.5	37.0	42.3	54.0	11.7	High	
14	7236.0	Horn XN	H/V	-	25.5	36.0	-	N/A	-	Low	
15	7311.0	Horn XN	H/V	-72.3	25.5	36.0	24.2	54.0	29.8	Mid, noise	
16	7386.0	Horn XN	H/V	-72.3	25.5	36.0	24.2	54.0	29.8	High, noise	
17	9648.0	Horn X	H/V	-	25.5	34.0	-	N/A	-	Low	
18	9748.0	Horn X	H/V	-	25.5	34.0	-	N/A	-	Mid	
19	9848.0	Horn X	H/V	-	25.5	34.0	-	N/A	-	High	
20	12060.0	Horn X	H/V	-72.5	25.5	34.0	26.0	54.0	28.0	Low, noise	
21	12185.0	Horn X	H/V	-72.7	25.5	34.0	25.8	54.0	28.2	Mid, noise	
22	12310.0	Horn X	H/V	-72.7	25.5	34.0	25.8	54.0	28.2	High, noise	
23	14472.0	Horn Ku	H/V	-78.8	25.5	17.3	36.4	54.0	17.6	Low, noise	
24	14622.0	Horn Ku	H/V	-	25.5	17.3	-	N/A	-	Mid	
25	14772.0	Horn Ku	H/V	-	25.5	17.3	-	N/A	-	High	
26	16884.0	Horn Ku	H/V	-	32.3	34.0	-	N/A	-	Low	
27	17059.0	Horn Ku	H/V	-	32.3	34.0	-	N/A	-	Mid	
28	17234.0	Horn Ku	H/V	-	32.3	34.0	-	N/A	-	High	
29	19296.0	Horn K	H/V	-71.8	32.3	32.0	35.5	54.0	18.5	Low, noise	
30	19496.0	Horn K	H/V	-71.5	32.3	32.0	35.8	54.0	18.2	Mid, noise	
31	19696.0	Horn K	H/V	-71.8	32.3	32.0	35.5	54.0	18.5	High, noise	
32	21708.0	Horn K	H/V	-	32.3	32.0	-	N/A	-	Low	
33	21933.0	Horn K	H/V	-	32.3	32.0	-	N/A	-	Mid	
34	22158.0	Horn K	H/V	-69.2	32.3	32.0	38.1	54.0	15.9	High, noise	
35	24120.0	Horn Ka	H/V	-	32.3	32.0	-	N/A	-	Low	
36	24370.0	Horn Ka	H/V	-	32.3	32.0	-	N/A	-	Mid	
37	24620.0	Horn Ka	H/V	-	32.3	32.0	-	N/A	-	High	
38											
39	Configuration:						* Ave: measured with 1 MHz RBW and 100 Hz VBW				
40	Pwr supp	DC Injector	Coax	Amp	Filter	Ant					
41	ACSM-26	Yes	150 ft	250mW	No	2403MU					
42											

Table 5.5 Highest Emissions Measured

Radiated Emissions										2405MU; 250mWB
#	Freq. MHz	Ant. Used	Ant. Pol.	Ave dBm	Ka dB/m	Kg dB	E3 dBμV/m	E3lim dBμV/m	Pass dB	Comments
1	2412.0									Low channel
2	2437.0									Mid channel
3	2462.0									High channel
4										
5	2390.0	Horn S	H/V	-62.0	21.5	26.5	40.0	54.0	14.0	Low
6	2390.0	Horn S	H/V	-65.4	21.5	26.5	36.6	54.0	17.4	Mid
7	2390.0	Horn S	H/V	-63.1	21.5	26.5	38.9	54.0	15.1	High
8	2483.5	Horn S	H/V	-70.3	21.5	23.8	34.4	54.0	19.6	Low
9	2483.5	Horn S	H/V	-69.2	21.5	23.8	35.5	54.0	18.5	Mid
10	2483.5	Horn S	H/V	-66.7	21.5	23.8	38.0	54.0	16.0	High
11	4824.0	Horn C	H/V	-58.5	25.5	37.0	37.0	54.0	17.0	Low
12	4874.0	Horn C	H/V	-62.0	25.5	37.0	33.5	54.0	20.5	Mid
13	4924.0	Horn C	H/V	-51.7	25.5	37.0	43.8	54.0	10.2	High
14	7236.0	Horn XN	H/V	-	25.5	36.0	-	N/A	-	Low
15	7311.0	Horn XN	H/V	-72.2	25.5	36.0	24.3	54.0	29.7	Mid, noise
16	7386.0	Horn XN	H/V	-71.8	25.5	36.0	24.7	54.0	29.3	High, noise
17	9648.0	Horn X	H/V	-	25.5	34.0	-	N/A	-	Low
18	9748.0	Horn X	H/V	-	25.5	34.0	-	N/A	-	Mid
19	9848.0	Horn X	H/V	-	25.5	34.0	-	N/A	-	High
20	12060.0	Horn X	H/V	-72.5	25.5	34.0	26.0	54.0	28.0	Low, noise
21	12185.0	Horn X	H/V	-72.8	25.5	34.0	25.7	54.0	28.3	Mid, noise
22	12310.0	Horn X	H/V	-72.8	25.5	34.0	25.7	54.0	28.3	High, noise
23	14472.0	Horn Ku	H/V	-78.9	25.5	17.3	36.3	54.0	17.7	Low, noise
24	14622.0	Horn Ku	H/V	-	25.5	17.3	-	N/A	-	Mid
25	14772.0	Horn Ku	H/V	-	25.5	17.3	-	N/A	-	High
26	16884.0	Horn Ku	H/V	-	32.3	34.0	-	N/A	-	Low
27	17059.0	Horn Ku	H/V	-	32.3	34.0	-	N/A	-	Mid
28	17234.0	Horn Ku	H/V	-	32.3	34.0	-	N/A	-	High
29	19296.0	Horn K	H/V	-71.8	32.3	32.0	35.5	54.0	18.5	Low, noise
30	19496.0	Horn K	H/V	-71.4	32.3	32.0	35.9	54.0	18.1	Mid, noise
31	19696.0	Horn K	H/V	-71.8	32.3	32.0	35.5	54.0	18.5	High, noise
32	21708.0	Horn K	H/V	-	32.3	32.0	-	N/A	-	Low
33	21933.0	Horn K	H/V	-	32.3	32.0	-	N/A	-	Mid
34	22158.0	Horn K	H/V	-69.2	32.3	32.0	38.1	54.0	15.9	High, noise
35	24120.0	Horn Ka	H/V	-	32.3	32.0	-	N/A	-	Low
36	24370.0	Horn Ka	H/V	-	32.3	32.0	-	N/A	-	Mid
37	24620.0	Horn Ka	H/V	-	32.3	32.0	-	N/A	-	High
38										
39	Configuration:						* Ave: measured with 1 MHz RBW and 100 Hz VBW			
40	Pwr supp	DC Injector	Coax	Amp	Filter	Ant				
41	ACSM-26	Yes	150 ft	250mW	No	2405MU				
42										

Table 5.6 Highest Emissions Measured

Radiated Emissions										2408P; 250mWB	
#	Freq. MHz	Ant. Used	Ant. Pol.	Ave dBm	Ka dB/m	Kg dB	E3 dBμV/m	E3lim dBμV/m	Pass dB	Comments	
1	2422.0									Low channel	
2	2437.0									Mid channel	
3	2462.0									High channel	
4											
5	2390.0	Horn S	H/V	-50.4	21.5	26.5	51.6	54.0	2.4	Low	
6	2390.0	Horn S	H/V	-54.3	21.5	26.5	47.7	54.0	6.3	Mid	
7	2390.0	Horn S	H/V	-51.6	21.5	26.5	50.4	54.0	3.6	High	
8	2483.5	Horn S	H/V	-58.3	21.5	23.8	46.4	54.0	7.6	Low	
9	2483.5	Horn S	H/V	-55.5	21.5	23.8	49.2	54.0	4.8	Mid	
10	2483.5	Horn S	H/V	-57.3	21.5	23.8	47.4	54.0	6.6	High	
11	4844.0	Horn C	H/V	-48.2	25.5	37.0	47.3	54.0	6.7	Low	
12	4874.0	Horn C	H/V	-45.1	25.5	37.0	50.4	54.0	3.6	Mid	
13	4924.0	Horn C	H/V	-46.2	25.5	37.0	49.3	54.0	4.7	High	
14	7266.0	Horn XN	H/V	-69.5	25.5	36.0	27.0	54.0	27.0	Low	
15	7311.0	Horn XN	H/V	-68.9	25.5	36.0	27.6	54.0	26.4	Mid	
16	7386.0	Horn XN	H/V	-69.1	25.5	36.0	27.4	54.0	26.6	High	
17	9688.0	Horn X	H/V	-	25.5	34.0	-	N/A	-	Low	
18	9748.0	Horn X	H/V	-	25.5	34.0	-	N/A	-	Mid	
19	9848.0	Horn X	H/V	-	25.5	34.0	-	N/A	-	High	
20	12110.0	Horn X	H/V	-72.8	25.5	34.0	25.7	54.0	28.3	Low, noise	
21	12185.0	Horn X	H/V	-72.7	25.5	34.0	25.8	54.0	28.2	Mid, noise	
22	12310.0	Horn X	H/V	-72.8	25.5	34.0	25.7	54.0	28.3	High, noise	
23	14532.0	Horn Ku	H/V	-	25.5	17.3	-	N/A	-	Low	
24	14622.0	Horn Ku	H/V	-	25.5	17.3	-	N/A	-	Mid	
25	14772.0	Horn Ku	H/V	-	25.5	17.3	-	N/A	-	High	
26	16954.0	Horn Ku	H/V	-	32.3	34.0	-	N/A	-	Low	
27	17059.0	Horn Ku	H/V	-	32.3	34.0	-	N/A	-	Mid	
28	17234.0	Horn Ku	H/V	-	32.3	34.0	-	N/A	-	High	
29	19376.0	Horn K	H/V	-72.0	32.3	32.0	35.3	54.0	18.7	Low, noise	
30	19496.0	Horn K	H/V	-71.9	32.3	32.0	35.4	54.0	18.6	Mid, noise	
31	19696.0	Horn K	H/V	-71.5	32.3	32.0	35.8	54.0	18.2	High, noise	
32	21798.0	Horn K	H/V	-	32.3	32.0	-	N/A	-	Low	
33	21933.0	Horn K	H/V	-	32.3	32.0	-	N/A	-	Mid	
34	22158.0	Horn K	H/V	-69.2	32.3	32.0	38.1	54.0	15.9	High, noise	
35	24220.0	Horn Ka	H/V	-	32.3	32.0	-	N/A	-	Low	
36	24370.0	Horn Ka	H/V	-	32.3	32.0	-	N/A	-	Mid	
37	24620.0	Horn Ka	H/V	-	32.3	32.0	-	N/A	-	High	
38											
39	Configuration:						* Ave: measured with 1 MHz RBW and 100 Hz VBW				
40	Pwr supp	DC Injector	Coax	Amp	Filter	Ant					
41	ACSM-26	Yes	150 ft	250mW	No	2408P					
42											

Table 5.7 Highest Emissions Measured

Radiated Emissions										2412P; 250mWB	
#	Freq. MHz	Ant. Used	Ant. Pol.	Ave dBm	Ka dB/m	Kg dB	E3 dBμV/m	E3lim dBμV/m	Pass dB	Comments	
1	2422.0									Low channel	
2	2437.0									Mid channel	
3	2462.0									High channel	
4											
5	2390.0	Horn S	H/V	-52.7	21.5	26.5	49.3	54.0	4.7	Low	
6	2390.0	Horn S	H/V	-53.0	21.5	26.5	49.0	54.0	5.0	Mid	
7	2390.0	Horn S	H/V	-51.7	21.5	26.5	50.3	54.0	3.7	High	
8	2483.5	Horn S	H/V	-60.6	21.5	23.8	44.1	54.0	9.9	Low	
9	2483.5	Horn S	H/V	-60.6	21.5	23.8	44.1	54.0	9.9	Mid	
10	2483.5	Horn S	H/V	-53.8	21.5	23.8	50.9	54.0	3.1	High	
11	4844.0	Horn C	H/V	-50.0	25.5	37.0	45.5	54.0	8.5	Low	
12	4874.0	Horn C	H/V	-46.2	25.5	37.0	49.3	54.0	4.7	Mid	
13	4924.0	Horn C	H/V	-47.4	25.5	37.0	48.1	54.0	5.9	High	
14	7266.0	Horn XN	H/V	-69.7	25.5	36.0	26.8	54.0	27.2	Low	
15	7311.0	Horn XN	H/V	-68.7	25.5	36.0	27.8	54.0	26.2	Mid	
16	7386.0	Horn XN	H/V	-69.1	25.5	36.0	27.4	54.0	26.6	High	
17	9688.0	Horn X	H/V	-	25.5	34.0	-	N/A	-	Low	
18	9748.0	Horn X	H/V	-	25.5	34.0	-	N/A	-	Mid	
19	9848.0	Horn X	H/V	-	25.5	34.0	-	N/A	-	High	
20	12110.0	Horn X	H/V	-72.7	25.5	34.0	25.8	54.0	28.2	Low, noise	
21	12185.0	Horn X	H/V	-72.7	25.5	34.0	25.8	54.0	28.2	Mid, noise	
22	12310.0	Horn X	H/V	-72.9	25.5	34.0	25.6	54.0	28.4	High, noise	
23	14532.0	Horn Ku	H/V	-	25.5	17.3	-	N/A	-	Low	
24	14622.0	Horn Ku	H/V	-	25.5	17.3	-	N/A	-	Mid	
25	14772.0	Horn Ku	H/V	-	25.5	17.3	-	N/A	-	High	
26	16954.0	Horn Ku	H/V	-	32.3	34.0	-	N/A	-	Low	
27	17059.0	Horn Ku	H/V	-	32.3	34.0	-	N/A	-	Mid	
28	17234.0	Horn Ku	H/V	-	32.3	34.0	-	N/A	-	High	
29	19376.0	Horn K	H/V	-71.9	32.3	32.0	35.4	54.0	18.6	Low, noise	
30	19496.0	Horn K	H/V	-71.6	32.3	32.0	35.7	54.0	18.3	Mid, noise	
31	19696.0	Horn K	H/V	-71.3	32.3	32.0	36.0	54.0	18.0	High, noise	
32	21798.0	Horn K	H/V	-	32.3	32.0	-	N/A	-	Low	
33	21933.0	Horn K	H/V	-	32.3	32.0	-	N/A	-	Mid	
34	22158.0	Horn K	H/V	-69.2	32.3	32.0	38.1	54.0	15.9	High, noise	
35	24220.0	Horn Ka	H/V	-	32.3	32.0	-	N/A	-	Low	
36	24370.0	Horn Ka	H/V	-	32.3	32.0	-	N/A	-	Mid	
37	24620.0	Horn Ka	H/V	-	32.3	32.0	-	N/A	-	High	
38											
39	Configuration:						* Ave: measured with 1 MHz RBW and 100 Hz VBW				
40	Pwr supp	DC Injector	Coax	Amp	Filter	Ant					
41	ACSM-26	Yes	150 ft	250mW	No	2412P					
42											

Table 5.8 Highest Emissions Measured

Radiated Emissions										2420P; 250mWB	
#	Freq. MHz	Ant. Used	Ant. Pol.	Ave dBm	Ka dB/m	Kg dB	E3 dBμV/m	E3lim dBμV/m	Pass dB	Comments	
1	2432.0									Low channel	
2	2437.0									Mid channel	
3	2442.0									High channel	
4											
5	2390.0	Horn S	H/V	-53.8	21.5	26.5	48.2	54.0	5.8	Low	
6	2390.0	Horn S	H/V	-53.2	21.5	26.5	48.8	54.0	5.2	Mid	
7	2390.0	Horn S	H/V	-52.9	21.5	26.5	49.1	54.0	4.9	High	
8	2483.5	Horn S	H/V	-61.8	21.5	23.8	42.9	54.0	11.1	Low	
9	2483.5	Horn S	H/V	-61.0	21.5	23.8	43.7	54.0	10.3	Mid	
10	2483.5	Horn S	H/V	-59.4	21.5	23.8	45.3	54.0	8.7	High	
11	4864.0	Horn C	H/V	-49.7	25.5	37.0	45.8	54.0	8.2	Low	
12	4874.0	Horn C	H/V	-50.4	25.5	37.0	45.1	54.0	8.9	Mid	
13	4884.0	Horn C	H/V	-45.1	25.5	37.0	50.4	54.0	3.6	High	
14	7296.0	Horn XN	H/V	-66.8	25.5	36.0	29.7	54.0	24.3	Low	
15	7311.0	Horn XN	H/V	-65.4	25.5	36.0	31.1	54.0	22.9	Mid	
16	7326.0	Horn XN	H/V	-67.3	25.5	36.0	29.2	54.0	24.8	High	
17	9728.0	Horn X	H/V	-	25.5	34.0	-	N/A	-	Low	
18	9748.0	Horn X	H/V	-	25.5	34.0	-	N/A	-	Mid	
19	9768.0	Horn X	H/V	-	25.5	34.0	-	N/A	-	High	
20	12160.0	Horn X	H/V	-72.8	25.5	34.0	25.7	54.0	28.3	Low, noise	
21	12185.0	Horn X	H/V	-72.7	25.5	34.0	25.8	54.0	28.2	Mid, noise	
22	12210.0	Horn X	H/V	-72.7	25.5	34.0	25.8	54.0	28.2	High, noise	
23	14592.0	Horn Ku	H/V	-	25.5	17.3	-	N/A	-	Low	
24	14622.0	Horn Ku	H/V	-	25.5	17.3	-	N/A	-	Mid	
25	14652.0	Horn Ku	H/V	-	25.5	17.3	-	N/A	-	High	
26	17024.0	Horn Ku	H/V	-	32.3	34.0	-	N/A	-	Low	
27	17059.0	Horn Ku	H/V	-	32.3	34.0	-	N/A	-	Mid	
28	17094.0	Horn Ku	H/V	-	32.3	34.0	-	N/A	-	High	
29	19456.0	Horn K	H/V	-71.8	32.3	32.0	35.5	54.0	18.5	Low, noise	
30	19496.0	Horn K	H/V	-71.4	32.3	32.0	35.9	54.0	18.1	Mid, noise	
31	19536.0	Horn K	H/V	-71.6	32.3	32.0	35.7	54.0	18.3	High, noise	
32	21888.0	Horn K	H/V	-	32.3	32.0	-	N/A	-	Low	
33	21933.0	Horn K	H/V	-	32.3	32.0	-	N/A	-	Mid	
34	21978.0	Horn K	H/V	-	32.3	32.0	-	N/A	-	High	
35	24320.0	Horn Ka	H/V	-	32.3	32.0	-	N/A	-	Low	
36	24370.0	Horn Ka	H/V	-	32.3	32.0	-	N/A	-	Mid	
37	24420.0	Horn Ka	H/V	-	32.3	32.0	-	N/A	-	High	
38											
39	Configuration:						* Ave: measured with 1 MHz RBW and 100 Hz VBW				
40	Pwr supp	DC Injector	Coax	Amp	Filter	Ant					
41	ACSM-26	Yes	150 ft	250mW	No	2420P					
42											

Table 5.9 Highest Emissions Measured

Radiated Emissions										2412Y; 250mWB	
#	Freq. MHz	Ant. Used	Ant. Pol.	Ave dBm	Ka dB/m	Kg dB	E3 dBμV/m	E3lim dBμV/m	Pass dB	Comments	
1	2432.0									Low channel	
2	2437.0									Mid channel	
3	2442.0									High channel	
4											
5	2390.0	Horn S	H/V	-50.1	21.5	26.5	51.9	54.0	2.1	Low	
6	2390.0	Horn S	H/V	-50.8	21.5	26.5	51.2	54.0	2.8	Mid	
7	2390.0	Horn S	H/V	-49.8	21.5	26.5	52.2	54.0	1.8	High	
8	2483.5	Horn S	H/V	-59.5	21.5	23.8	45.2	54.0	8.8	Low	
9	2483.5	Horn S	H/V	-59.7	21.5	23.8	45.0	54.0	9.0	Mid	
10	2483.5	Horn S	H/V	-55.1	21.5	23.8	49.6	54.0	4.4	High	
11	4864.0	Horn C	H/V	-48.1	25.5	37.0	47.4	54.0	6.6	Low	
12	4874.0	Horn C	H/V	-48.4	25.5	37.0	47.1	54.0	6.9	Mid	
13	4884.0	Horn C	H/V	-46.1	25.5	37.0	49.4	54.0	4.6	High	
14	7296.0	Horn XN	H/V	-69.0	25.5	36.0	27.5	54.0	26.5	Low	
15	7311.0	Horn XN	H/V	-69.1	25.5	36.0	27.4	54.0	26.6	Mid	
16	7326.0	Horn XN	H/V	-68.2	25.5	36.0	28.3	54.0	25.7	High	
17	9728.0	Horn X	H/V	-	25.5	34.0	-	N/A	-	Low	
18	9748.0	Horn X	H/V	-	25.5	34.0	-	N/A	-	Mid	
19	9768.0	Horn X	H/V	-	25.5	34.0	-	N/A	-	High	
20	12160.0	Horn X	H/V	-72.7	25.5	34.0	25.8	54.0	28.2	Low, noise	
21	12185.0	Horn X	H/V	-72.8	25.5	34.0	25.7	54.0	28.3	Mid, noise	
22	12210.0	Horn X	H/V	-72.4	25.5	34.0	26.1	54.0	27.9	High, noise	
23	14592.0	Horn Ku	H/V	-	25.5	17.3	-	N/A	-	Low	
24	14622.0	Horn Ku	H/V	-	25.5	17.3	-	N/A	-	Mid	
25	14652.0	Horn Ku	H/V	-	25.5	17.3	-	N/A	-	High	
26	17024.0	Horn Ku	H/V	-	32.3	34.0	-	N/A	-	Low	
27	17059.0	Horn Ku	H/V	-	32.3	34.0	-	N/A	-	Mid	
28	17094.0	Horn Ku	H/V	-	32.3	34.0	-	N/A	-	High	
29	19456.0	Horn K	H/V	-72.0	32.3	32.0	35.3	54.0	18.7	Low, noise	
30	19496.0	Horn K	H/V	-71.4	32.3	32.0	35.9	54.0	18.1	Mid, noise	
31	19536.0	Horn K	H/V	-71.6	32.3	32.0	35.7	54.0	18.3	High, noise	
32	21888.0	Horn K	H/V	-	32.3	32.0	-	N/A	-	Low	
33	21933.0	Horn K	H/V	-	32.3	32.0	-	N/A	-	Mid	
34	21978.0	Horn K	H/V	-	32.3	32.0	-	N/A	-	High	
35	24320.0	Horn Ka	H/V	-	32.3	32.0	-	N/A	-	Low	
36	24370.0	Horn Ka	H/V	-	32.3	32.0	-	N/A	-	Mid	
37	24420.0	Horn Ka	H/V	-	32.3	32.0	-	N/A	-	High	
38											
39	Configuration:						* Ave: measured with 1 MHz RBW and 100 Hz VBW				
40	Pwr supp	DC Injector	Coax	Amp	Filter	Ant					
41	ACSM-26	Yes	150 ft	250mW	No	2412Y					
42											

Table 5.10 Highest Emissions Measured

Radiated Emissions										2415Y; 250mWB	
#	Freq. MHz	Ant. Used	Ant. Pol.	Ave dBm	Ka dB/m	Kg dB	E3 dBμV/m	E3lim dBμV/m	Pass dB	Comments	
1	2417.0									Low channel	
2	2437.0									Mid channel	
3	2452.0									High channel	
4											
5	2390.0	Horn S	H/V	-52.4	21.5	26.5	49.6	54.0	4.4	Low	
6	2390.0	Horn S	H/V	-57.7	21.5	26.5	44.3	54.0	9.7	Mid	
7	2390.0	Horn S	H/V	-58.6	21.5	26.5	43.4	54.0	10.6	High	
8	2483.5	Horn S	H/V	-69.5	21.5	23.8	35.2	54.0	18.8	Low	
9	2483.5	Horn S	H/V	-70.4	21.5	23.8	34.3	54.0	19.7	Mid	
10	2483.5	Horn S	H/V	-66.7	21.5	23.8	38.0	54.0	16.0	High	
11	4834.0	Horn C	H/V	-46.2	25.5	37.0	49.3	54.0	4.7	Low	
12	4874.0	Horn C	H/V	-45.2	25.5	37.0	50.3	54.0	3.7	Mid	
13	4904.0	Horn C	H/V	-46.3	25.5	37.0	49.2	54.0	4.8	High	
14	7251.0	Horn XN	H/V	-69.5	25.5	36.0	27.0	54.0	27.0	Low	
15	7311.0	Horn XN	H/V	-68.9	25.5	36.0	27.6	54.0	26.4	Mid	
16	7356.0	Horn XN	H/V	-70.1	25.5	36.0	26.4	54.0	27.6	High	
17	9668.0	Horn X	H/V	-	25.5	34.0	-	N/A	-	Low	
18	9748.0	Horn X	H/V	-	25.5	34.0	-	N/A	-	Mid	
19	9808.0	Horn X	H/V	-	25.5	34.0	-	N/A	-	High	
20	12085.0	Horn X	H/V	-72.8	25.5	34.0	25.7	54.0	28.3	Low, noise	
21	12185.0	Horn X	H/V	-72.9	25.5	34.0	25.6	54.0	28.4	Mid, noise	
22	12260.0	Horn X	H/V	-72.8	25.5	34.0	25.7	54.0	28.3	High, noise	
23	14502.0	Horn Ku	H/V	-	25.5	17.3	-	N/A	-	Low	
24	14622.0	Horn Ku	H/V	-	25.5	17.3	-	N/A	-	Mid	
25	14712.0	Horn Ku	H/V	-	25.5	17.3	-	N/A	-	High	
26	16919.0	Horn Ku	H/V	-	32.3	34.0	-	N/A	-	Low	
27	17059.0	Horn Ku	H/V	-	32.3	34.0	-	N/A	-	Mid	
28	17164.0	Horn Ku	H/V	-	32.3	34.0	-	N/A	-	High	
29	19336.0	Horn K	H/V	-72.3	32.3	32.0	35.0	54.0	19.0	Low, noise	
30	19496.0	Horn K	H/V	-72.1	32.3	32.0	35.2	54.0	18.8	Mid, noise	
31	19616.0	Horn K	H/V	-72.0	32.3	32.0	35.3	54.0	18.7	High, noise	
32	21753.0	Horn K	H/V	-	32.3	32.0	-	N/A	-	Low	
33	21933.0	Horn K	H/V	-	32.3	32.0	-	N/A	-	Mid	
34	22068.0	Horn K	H/V	-69.1	32.3	32.0	38.2	54.0	15.8	High, noise	
35	24170.0	Horn Ka	H/V	-	32.3	32.0	-	N/A	-	Low	
36	24370.0	Horn Ka	H/V	-	32.3	32.0	-	N/A	-	Mid	
37	24520.0	Horn Ka	H/V	-	32.3	32.0	-	N/A	-	High	
38											
39	Configuration:						* Ave: measured with 1 MHz RBW and 100 Hz VBW				
40	Pwr supp	DC Injector	Coax	Amp	Filter	Ant					
41	ACSM-26	Yes	150 ft	250mW	No	2415Y					
42											

Table 5.11 Highest Emissions Measured

Radiated Emissions										2414D; 250mWB	
#	Freq. MHz	Ant. Used	Ant. Pol.	Ave dBm	Ka dB/m	Kg dB	E3 dBμV/m	E3lim dBμV/m	Pass dB	Comments	
1	2422.0									Low channel	
2	2437.0									Mid channel	
3	2442.0									High channel	
4											
5	2390.0	Horn S	H/V	-48.9	21.5	26.5	53.1	54.0	0.9	Low	
6	2390.0	Horn S	H/V	-51.2	21.5	26.5	50.8	54.0	3.2	Mid	
7	2390.0	Horn S	H/V	-50.2	21.5	26.5	51.8	54.0	2.2	High	
8	2483.5	Horn S	H/V	-58.4	21.5	23.8	46.3	54.0	7.7	Low	
9	2483.5	Horn S	H/V	-58.0	21.5	23.8	46.7	54.0	7.3	Mid	
10	2483.5	Horn S	H/V	-58.4	21.5	23.8	46.3	54.0	7.7	High	
11	4844.0	Horn C	H/V	-44.8	25.5	37.0	50.7	54.0	3.3	Low	
12	4874.0	Horn C	H/V	-47.0	25.5	37.0	48.5	54.0	5.5	Mid	
13	4884.0	Horn C	H/V	-47.3	25.5	37.0	48.2	54.0	5.8	High	
14	7266.0	Horn XN	H/V	-69.1	25.5	36.0	27.4	54.0	26.6	Low	
15	7311.0	Horn XN	H/V	-67.3	25.5	36.0	29.2	54.0	24.8	Mid	
16	7326.0	Horn XN	H/V	-68.0	25.5	36.0	28.5	54.0	25.5	High	
17	9688.0	Horn X	H/V	-	25.5	34.0	-	N/A	-	Low	
18	9748.0	Horn X	H/V	-	25.5	34.0	-	N/A	-	Mid	
19	9768.0	Horn X	H/V	-	25.5	34.0	-	N/A	-	High	
20	12110.0	Horn X	H/V	-72.7	25.5	34.0	25.8	54.0	28.2	Low, noise	
21	12185.0	Horn X	H/V	-72.8	25.5	34.0	25.7	54.0	28.3	Mid, noise	
22	12210.0	Horn X	H/V	-71.9	25.5	34.0	26.6	54.0	27.4	High, noise	
23	14532.0	Horn Ku	H/V	-	25.5	17.3	-	N/A	-	Low	
24	14622.0	Horn Ku	H/V	-	25.5	17.3	-	N/A	-	Mid	
25	14652.0	Horn Ku	H/V	-	25.5	17.3	-	N/A	-	High	
26	16954.0	Horn Ku	H/V	-	32.3	34.0	-	N/A	-	Low	
27	17059.0	Horn Ku	H/V	-	32.3	34.0	-	N/A	-	Mid	
28	17094.0	Horn Ku	H/V	-	32.3	34.0	-	N/A	-	High	
29	19376.0	Horn K	H/V	-72.4	32.3	32.0	34.9	54.0	19.1	Low, noise	
30	19496.0	Horn K	H/V	-72.1	32.3	32.0	35.2	54.0	18.8	Mid, noise	
31	19536.0	Horn K	H/V	-71.4	32.3	32.0	35.9	54.0	18.1	High, noise	
32	21798.0	Horn K	H/V	-	32.3	32.0	-	N/A	-	Low	
33	21933.0	Horn K	H/V	-	32.3	32.0	-	N/A	-	Mid	
34	21978.0	Horn K	H/V	-	32.3	32.0	-	N/A	-	High, noise	
35	24220.0	Horn Ka	H/V	-	32.3	32.0	-	N/A	-	Low	
36	24370.0	Horn Ka	H/V	-	32.3	32.0	-	N/A	-	Mid	
37	24420.0	Horn Ka	H/V	-	32.3	32.0	-	N/A	-	High	
38											
39	Configuration:						* Ave: measured with 1 MHz RBW and 100 Hz VBW				
40	Pwr supp	DC Injector	Coax	Amp	Filter	Ant					
41	ACSM-26	Yes	150 ft	250mW	No	2414D					
42											

Table 5.12 Highest Emissions Measured

Radiated Emissions										2415G; 250mWB	
#	Freq. MHz	Ant. Used	Ant. Pol.	Ave dBm	Ka dB/m	Kg dB	E3 dBμV/m	E3lim dBμV/m	Pass dB	Comments	
1	2422.0									Low channel	
2	2437.0									Mid channel	
3	2447.0									High channel	
4											
5	2390.0	Horn S	H/V	-52.7	21.5	26.5	49.3	54.0	4.7	Low	
6	2390.0	Horn S	H/V	-51.7	21.5	26.5	50.3	54.0	3.7	Mid	
7	2390.0	Horn S	H/V	-54.2	21.5	26.5	47.8	54.0	6.2	High	
8	2483.5	Horn S	H/V	-58.8	21.5	23.8	45.9	54.0	8.1	Low	
9	2483.5	Horn S	H/V	-58.3	21.5	23.8	46.4	54.0	7.6	Mid	
10	2483.5	Horn S	H/V	-53.7	21.5	23.8	51.0	54.0	3.0	High	
11	4844.0	Horn C	H/V	-43.9	25.5	37.0	51.6	54.0	2.4	Low	
12	4874.0	Horn C	H/V	-46.3	25.5	37.0	49.2	54.0	4.8	Mid	
13	4894.0	Horn C	H/V	-44.0	25.5	37.0	51.5	54.0	2.5	High	
14	7266.0	Horn XN	H/V	-68.9	25.5	36.0	27.6	54.0	26.4	Low	
15	7311.0	Horn XN	H/V	-67.1	25.5	36.0	29.4	54.0	24.6	Mid	
16	7341.0	Horn XN	H/V	-77.7	25.5	36.0	18.8	54.0	35.2	High	
17	9688.0	Horn X	H/V	-	25.5	34.0	-	N/A	-	Low	
18	9748.0	Horn X	H/V	-	25.5	34.0	-	N/A	-	Mid	
19	9788.0	Horn X	H/V	-	25.5	34.0	-	N/A	-	High	
20	12110.0	Horn X	H/V	-72.8	25.5	34.0	25.7	54.0	28.3	Low, noise	
21	12185.0	Horn X	H/V	-72.8	25.5	34.0	25.7	54.0	28.3	Mid, noise	
22	12235.0	Horn X	H/V	-72.0	25.5	34.0	26.5	54.0	27.5	High, noise	
23	14532.0	Horn Ku	H/V	-	25.5	17.3	-	N/A	-	Low	
24	14622.0	Horn Ku	H/V	-	25.5	17.3	-	N/A	-	Mid	
25	14682.0	Horn Ku	H/V	-	25.5	17.3	-	N/A	-	High	
26	16954.0	Horn Ku	H/V	-	32.3	34.0	-	N/A	-	Low	
27	17059.0	Horn Ku	H/V	-	32.3	34.0	-	N/A	-	Mid	
28	17129.0	Horn Ku	H/V	-	32.3	34.0	-	N/A	-	High	
29	19376.0	Horn K	H/V	-72.5	32.3	32.0	34.8	54.0	19.2	Low, noise	
30	19496.0	Horn K	H/V	-72.3	32.3	32.0	35.0	54.0	19.0	Mid, noise	
31	19576.0	Horn K	H/V	-71.3	32.3	32.0	36.0	54.0	18.0	High, noise	
32	21798.0	Horn K	H/V	-	32.3	32.0	-	N/A	-	Low	
33	21933.0	Horn K	H/V	-	32.3	32.0	-	N/A	-	Mid	
34	22023.0	Horn K	H/V	-68.9	32.3	32.0	38.4	54.0	15.6	High, noise	
35	24220.0	Horn Ka	H/V	-	32.3	32.0	-	N/A	-	Low	
36	24370.0	Horn Ka	H/V	-	32.3	32.0	-	N/A	-	Mid	
37	24470.0	Horn Ka	H/V	-	32.3	32.0	-	N/A	-	High	
38											
39	Configuration:						* Ave: measured with 1 MHz RBW and 100 Hz VBW				
40	Pwr supp	DC Injector	Coax	Amp	Filter	Ant					
41	ACSM-26	Yes	150 ft	250mW	No	2415G					
42											

Table 5.13 Highest Emissions Measured

Radiated Emissions										2424G; 250mWB	
#	Freq. MHz	Ant. Used	Ant. Pol.	Ave dBm	Ka dB/m	Kg dB	E3 dBμV/m	E3lim dBμV/m	Pass dB	Comments	
1	2437.0									Low channel	
2	2437.0									Mid channel	
3	2437.0									High channel	
4											
5	2390.0	Horn S	H/V	-50.4	21.5	26.5	51.6	54.0	2.4	Low	
6	2390.0	Horn S	H/V	-50.4	21.5	26.5	51.6	54.0	2.4	Mid	
7	2390.0	Horn S	H/V	-50.4	21.5	26.5	51.6	54.0	2.4	High	
8	2483.5	Horn S	H/V	-65.1	21.5	23.8	39.6	54.0	14.4	Low	
9	2483.5	Horn S	H/V	-65.1	21.5	23.8	39.6	54.0	14.4	Mid	
10	2483.5	Horn S	H/V	-65.1	21.5	23.8	39.6	54.0	14.4	High	
11	4874.0	Horn C	H/V	-54.2	25.5	37.0	41.3	54.0	12.7	Low	
12	4874.0	Horn C	H/V	-54.2	25.5	37.0	41.3	54.0	12.7	Mid	
13	4874.0	Horn C	H/V	-54.2	25.5	37.0	41.3	54.0	12.7	High	
14	7311.0	Horn XN	H/V	-60.4	25.5	36.0	36.1	54.0	17.9	Low	
15	7311.0	Horn XN	H/V	-60.4	25.5	36.0	36.1	54.0	17.9	Mid	
16	7311.0	Horn XN	H/V	-60.4	25.5	36.0	36.1	54.0	17.9	High	
17	9748.0	Horn X	H/V	-	25.5	34.0	-	N/A	-	Low	
18	9748.0	Horn X	H/V	-	25.5	34.0	-	N/A	-	Mid	
19	9748.0	Horn X	H/V	-	25.5	34.0	-	N/A	-	High	
20	12185.0	Horn X	H/V	-72.7	25.5	34.0	25.8	54.0	28.2	Low, noise	
21	12185.0	Horn X	H/V	-72.7	25.5	34.0	25.8	54.0	28.2	Mid, noise	
22	12185.0	Horn X	H/V	-72.7	25.5	34.0	25.8	54.0	28.2	High, noise	
23	14622.0	Horn Ku	H/V	-	25.5	17.3	-	N/A	-	Low	
24	14622.0	Horn Ku	H/V	-	25.5	17.3	-	N/A	-	Mid	
25	14622.0	Horn Ku	H/V	-	25.5	17.3	-	N/A	-	High	
26	17059.0	Horn Ku	H/V	-	32.3	34.0	-	N/A	-	Low	
27	17059.0	Horn Ku	H/V	-	32.3	34.0	-	N/A	-	Mid	
28	17059.0	Horn Ku	H/V	-	32.3	34.0	-	N/A	-	High	
29	19496.0	Horn K	H/V	-71.2	32.3	32.0	36.1	54.0	17.9	Low, noise	
30	19496.0	Horn K	H/V	-71.2	32.3	32.0	36.1	54.0	17.9	Mid, noise	
31	19496.0	Horn K	H/V	-71.2	32.3	32.0	36.1	54.0	17.9	High, noise	
32	21933.0	Horn K	H/V	-	32.3	32.0	-	N/A	-	Low	
33	21933.0	Horn K	H/V	-	32.3	32.0	-	N/A	-	Mid	
34	21933.0	Horn K	H/V	-	32.3	32.0	-	N/A	-	High	
35	24370.0	Horn Ka	H/V	-	32.3	32.0	-	N/A	-	Low	
36	24370.0	Horn Ka	H/V	-	32.3	32.0	-	N/A	-	Mid	
37	24370.0	Horn Ka	H/V	-	32.3	32.0	-	N/A	-	High	
38											
39	Configuration:						* Ave: measured with 1 MHz RBW and 100 Hz VBW				
40	Pwr supp	DC Injector	Coax	Amp	Filter	Ant					
41	ACSM-26	Yes	150 ft	250mW	BLK	2424G					
42											

Table 5.14 Highest Emissions Measured

Radiated Emissions										2424G; No AMP	
#	Freq. MHz	Ant. Used	Ant. Pol.	Ave dBm	Ka dB/m	Kg dB	E3 dBμV/m	E3lim dBμV/m	Pass dB	Comments	
1	2412.0									Low channel	
2	2437.0									Mid channel	
3	2462.0									High channel	
4											
5	2390.0	Horn S	H/V	-58.3	21.5	26.5	43.7	54.0	10.3	Low	
6	2390.0	Horn S	H/V	-60.2	21.5	26.5	41.8	54.0	12.2	Mid	
7	2390.0	Horn S	H/V	-58.2	21.5	26.5	43.8	54.0	10.2	High	
8	2483.5	Horn S	H/V	-60.2	21.5	23.8	44.5	54.0	9.5	Low	
9	2483.5	Horn S	H/V	-61.3	21.5	23.8	43.4	54.0	10.6	Mid	
10	2483.5	Horn S	H/V	-53.7	21.5	23.8	51.0	54.0	3.0	High	
11	4824.0	Horn C	H/V	-58.1	25.5	37.0	37.4	54.0	16.6	Low	
12	4874.0	Horn C	H/V	-55.3	25.5	37.0	40.2	54.0	13.8	Mid	
13	4924.0	Horn C	H/V	-57.9	25.5	37.0	37.6	54.0	16.4	High	
14	7236.0	Horn XN	H/V	-	25.5	36.0	-	N/A	-	Low	
15	7311.0	Horn XN	H/V	-72.1	25.5	36.0	24.4	54.0	29.6	Mid	
16	7386.0	Horn XN	H/V	-72.0	25.5	36.0	24.5	54.0	29.5	High	
17	9648.0	Horn X	H/V	-	25.5	34.0	-	N/A	-	Low	
18	9748.0	Horn X	H/V	-	25.5	34.0	-	N/A	-	Mid	
19	9848.0	Horn X	H/V	-	25.5	34.0	-	N/A	-	High	
20	12060.0	Horn X	H/V	-72.5	25.5	34.0	26.0	54.0	28.0	Low, noise	
21	12185.0	Horn X	H/V	-72.7	25.5	34.0	25.8	54.0	28.2	Mid, noise	
22	12310.0	Horn X	H/V	-72.2	25.5	34.0	26.3	54.0	27.7	High, noise	
23	14472.0	Horn Ku	H/V	-78.7	25.5	17.3	36.5	54.0	17.5	Low, noise	
24	14622.0	Horn Ku	H/V	-	25.5	17.3	-	N/A	-	Mid	
25	14772.0	Horn Ku	H/V	-	25.5	17.3	-	N/A	-	High	
26	16884.0	Horn Ku	H/V	-	32.3	34.0	-	N/A	-	Low	
27	17059.0	Horn Ku	H/V	-	32.3	34.0	-	N/A	-	Mid	
28	17234.0	Horn Ku	H/V	-	32.3	34.0	-	N/A	-	High	
29	19296.0	Horn K	H/V	-72.3	32.3	32.0	35.0	54.0	19.0	Low, noise	
30	19496.0	Horn K	H/V	-72.0	32.3	32.0	35.3	54.0	18.7	Mid, noise	
31	19696.0	Horn K	H/V	-77.9	32.3	32.0	29.4	54.0	24.6	High, noise	
32	21708.0	Horn K	H/V	-	32.3	32.0	-	N/A	-	Low	
33	21933.0	Horn K	H/V	-	32.3	32.0	-	N/A	-	Mid	
34	22158.0	Horn K	H/V	-69.1	32.3	32.0	38.2	54.0	15.8	High, noise	
35	24120.0	Horn Ka	H/V	-	32.3	32.0	-	N/A	-	Low	
36	24370.0	Horn Ka	H/V	-	32.3	32.0	-	N/A	-	Mid	
37	24620.0	Horn Ka	H/V	-	32.3	32.0	-	N/A	-	High	
38											
39	Configuration:						* Ave: measured with 1 MHz RBW and 100 Hz VBW				
40	Pwr supp	DC Injector	Coax	Amp	Filter	Ant					
41	None	No	150 ft	No	No	2424G					
42											

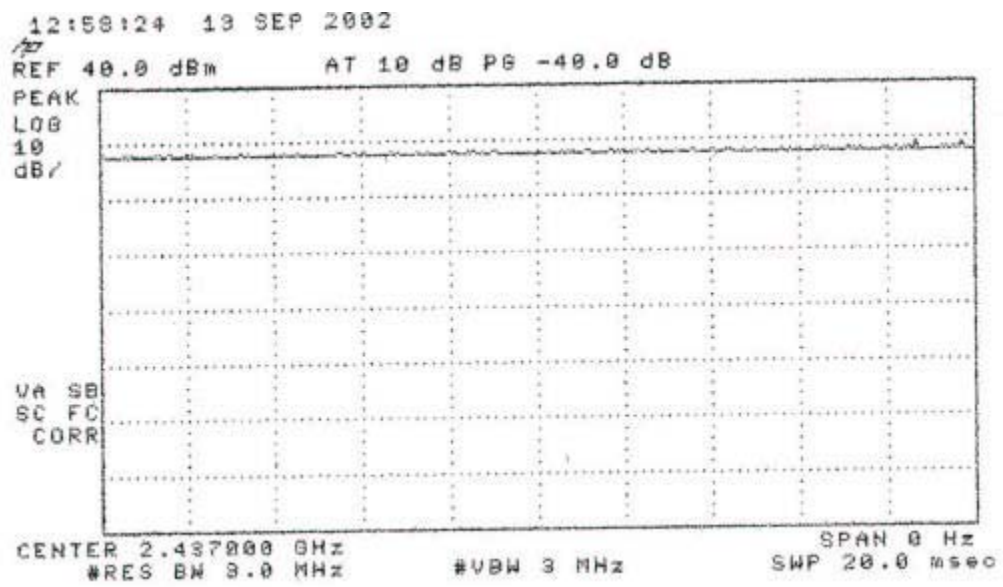

Figure 6.1 Demonstration of CW operation.

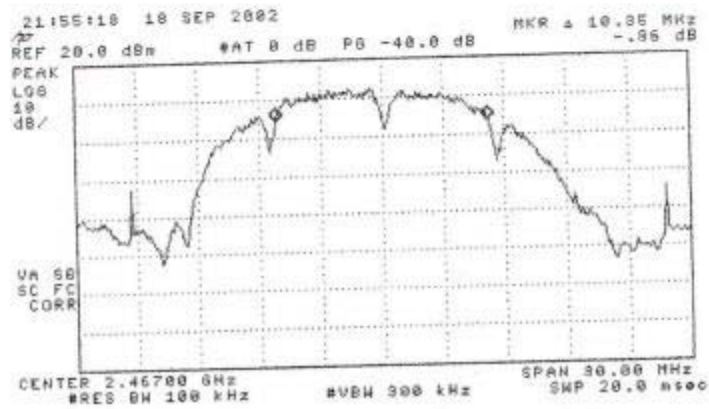
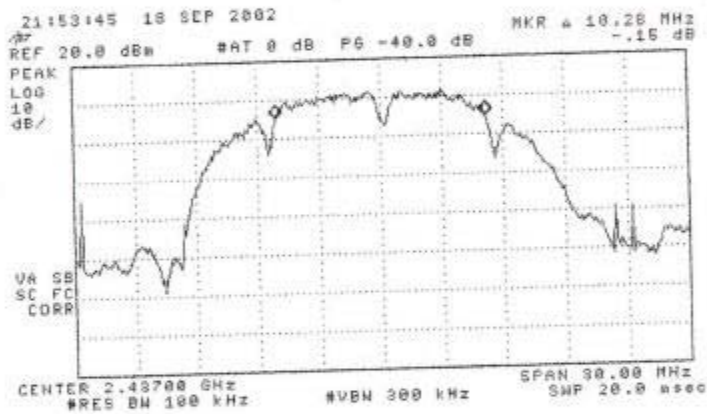
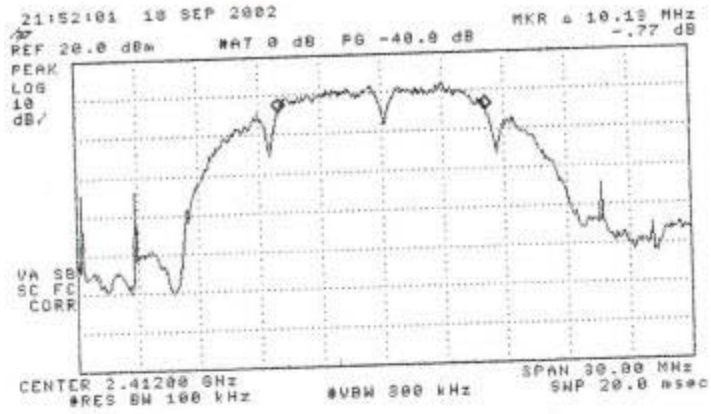

Figure 6.2(a) 6 dB-point bandwidth measurements; low, mid, and high channels.

HA2401-AGC-250 Amplifier (250 mW)

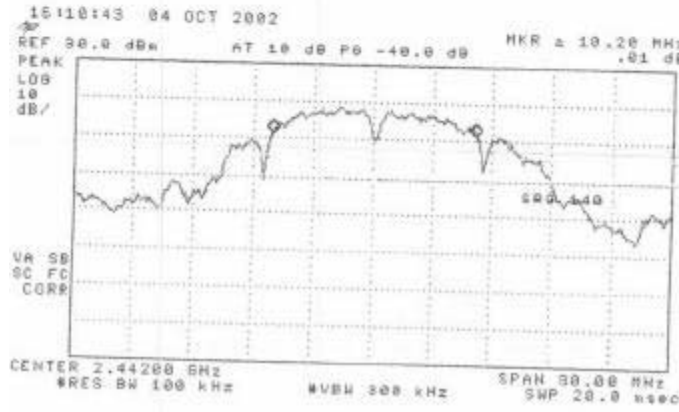
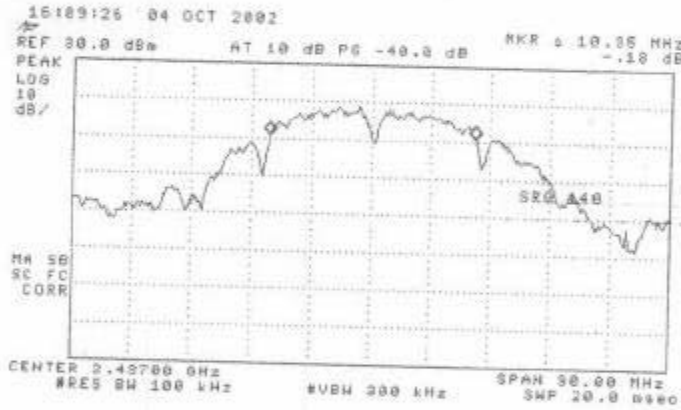
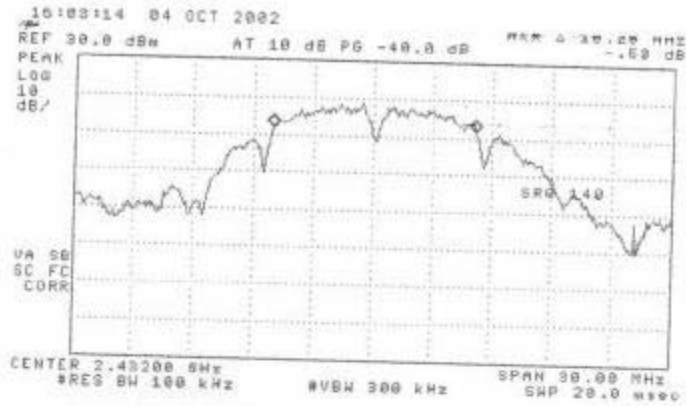

Figure 6.2(b) 6 dB-point bandwidth measurements; low, mid, and high channels.
 HA2401-AGC1000 Amplifier (1000 mW)

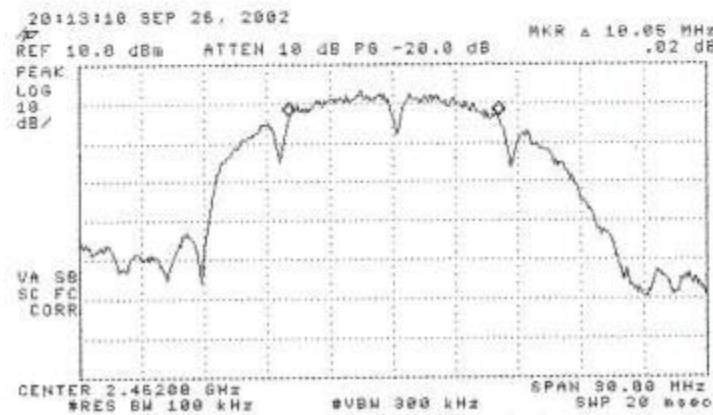
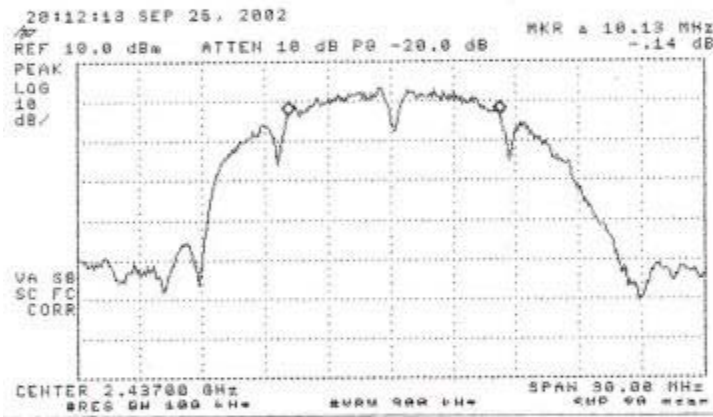
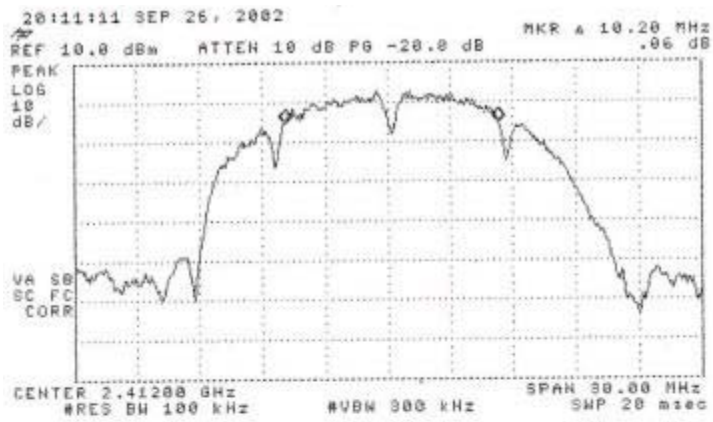

Figure 6.2(c) 6 dB-point bandwidth measurements; low, mid, and high channels.

Radio Alone (No Amplifier)

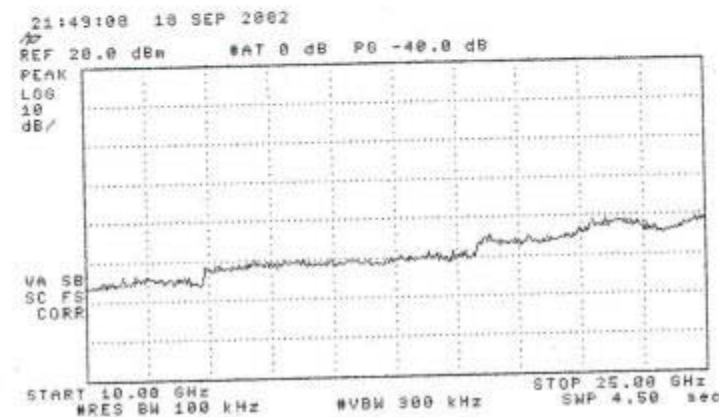
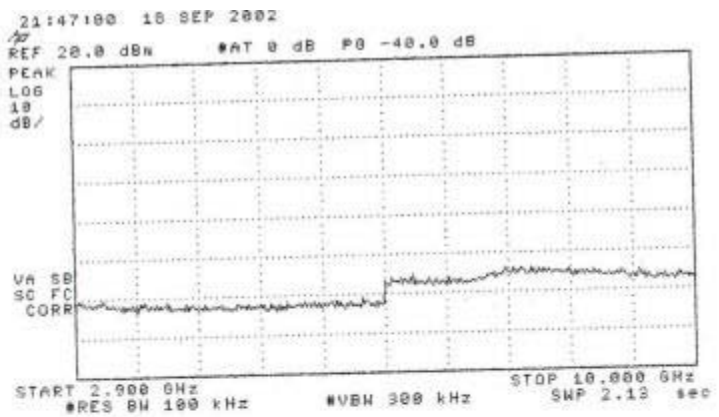
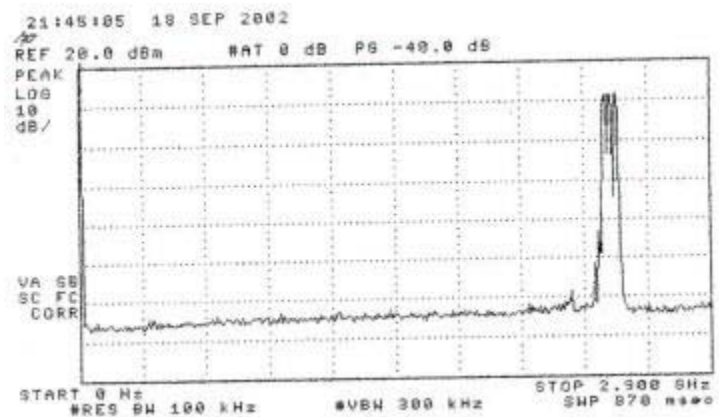

Figure 6.3(a) Antenna conducted spurious emissions; low, mid, and high channels.
HA2401-AGC-250 Amplifier (250 mW)

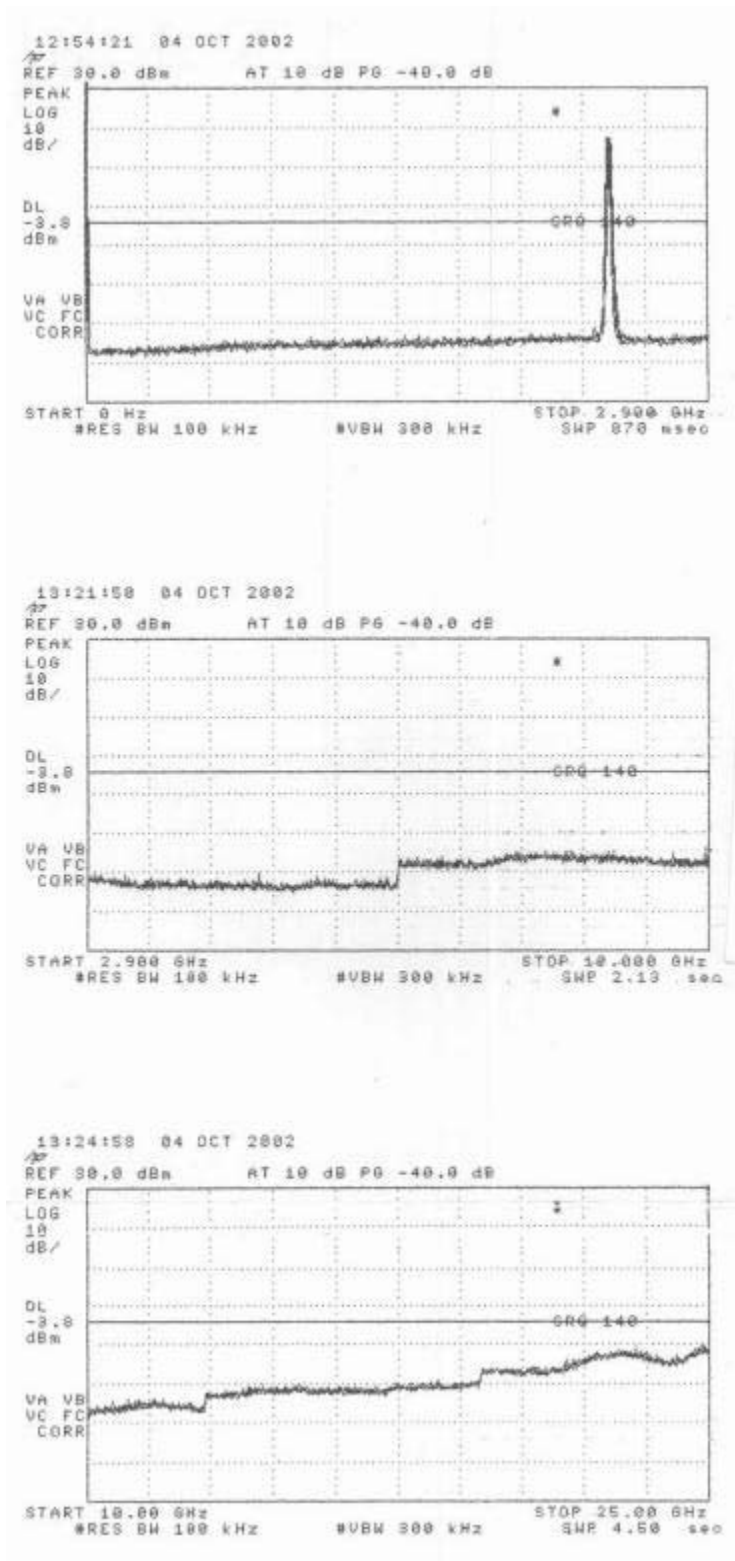

Figure 6.3(b) Antenna conducted spurious emissions; low, mid, and high channels.

HA2401-AGC1000 Amplifier (1000 mW)

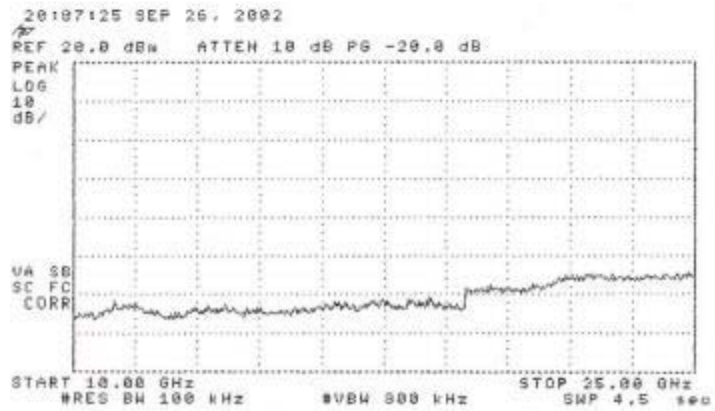
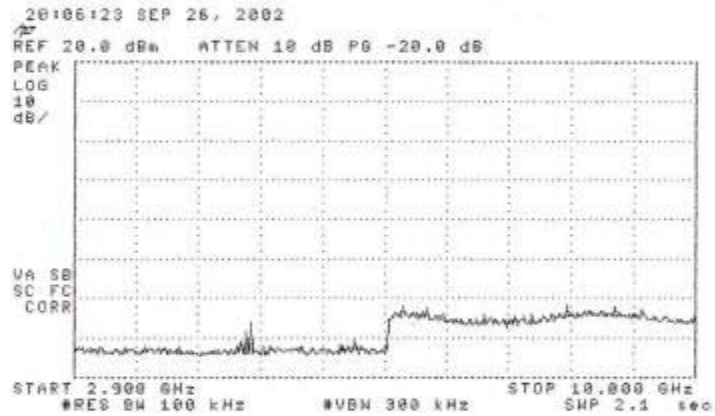
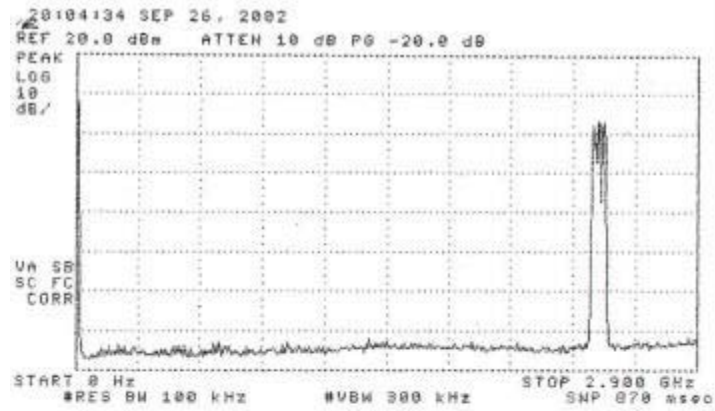

Figure 6.3(b) Antenna conducted spurious emissions; low, mid, and high channels.

Radio Alone (No Amplifier)

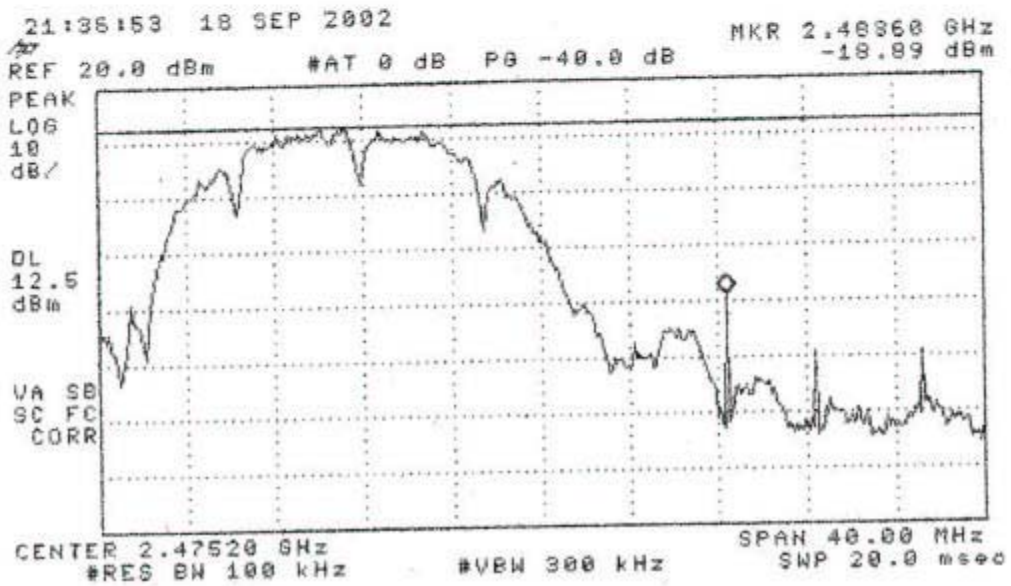
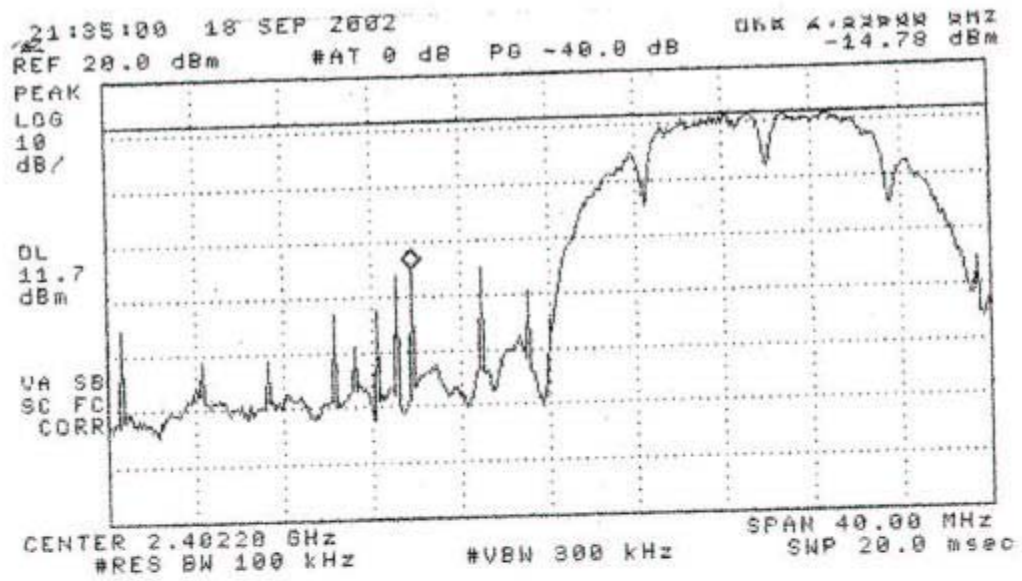

Figure 6.4(a) Band-edge behavior at low end and high end of the band.

HA2401-AGC-250 Amplifier (250 mW)

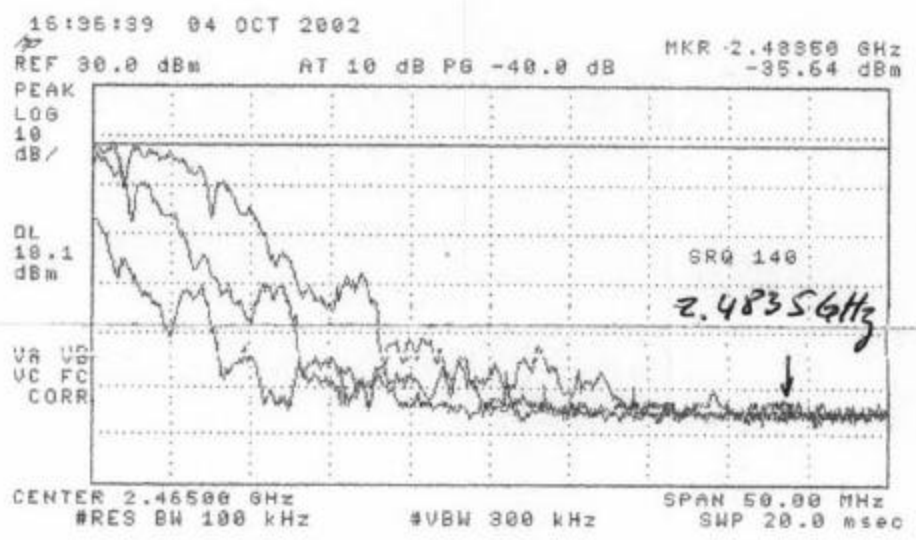
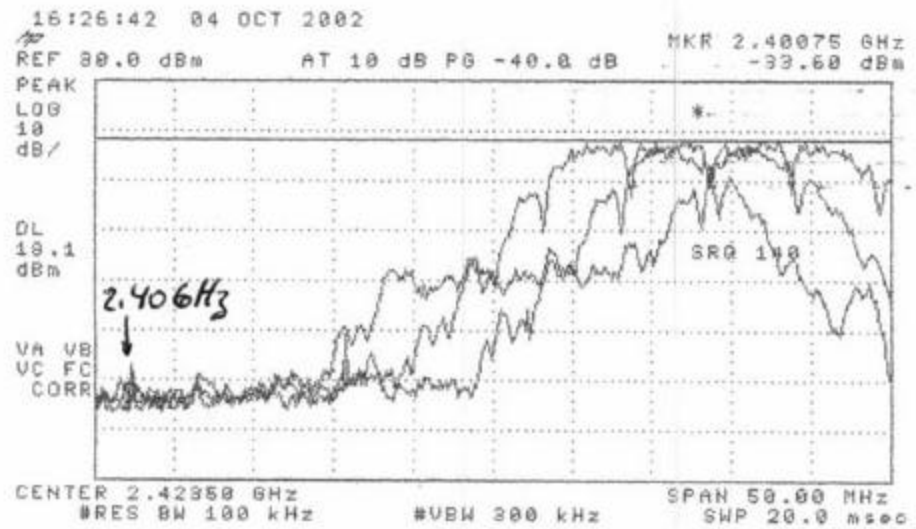

Figure 6.4(b) Band-edge behavior at low end and high end of the band.
 HA2401-AGC1000 Amplifier (1000 mW)

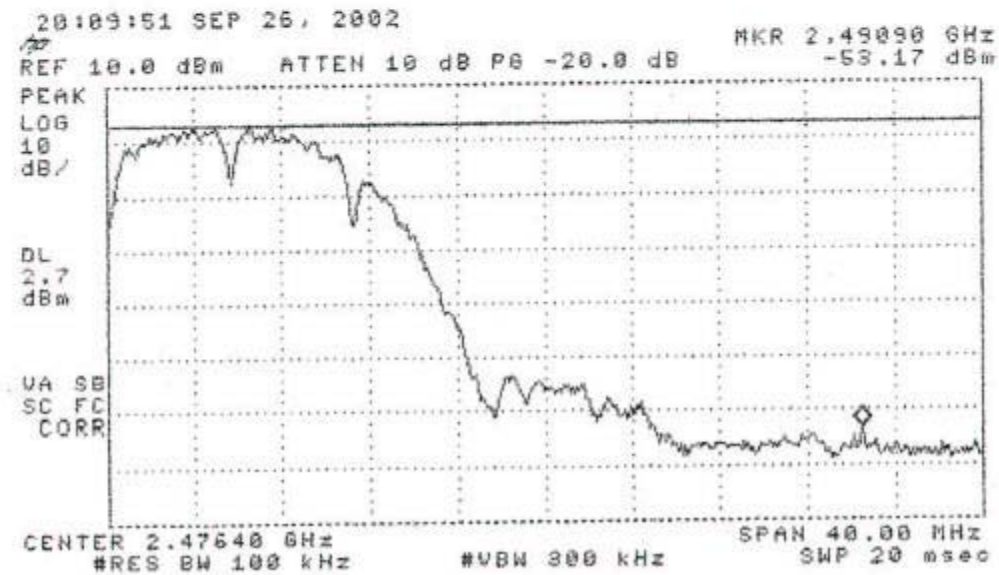
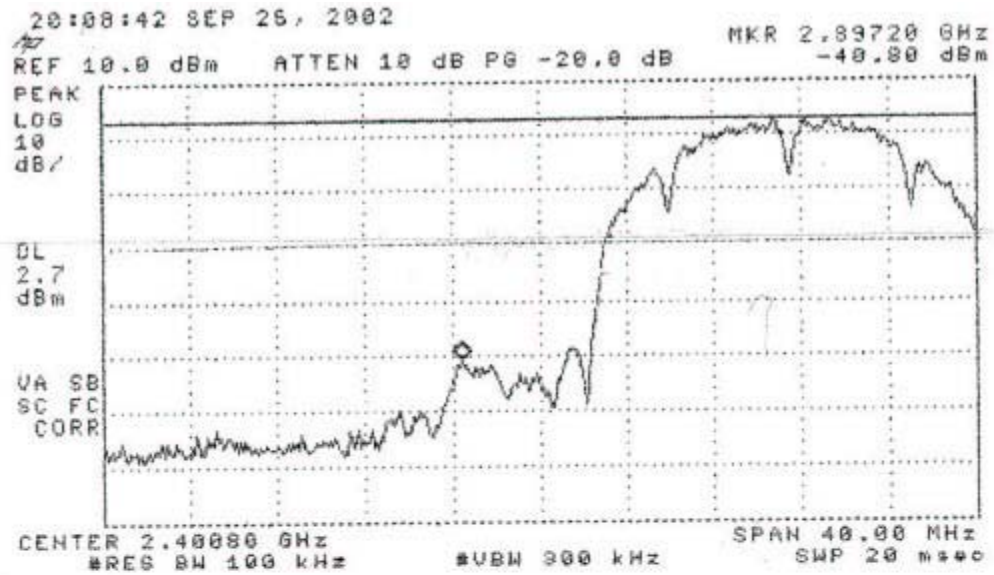

Figure 6.4(b) Band-edge behavior at low end and high end of the band.

Radio Alone (No Amplifier)

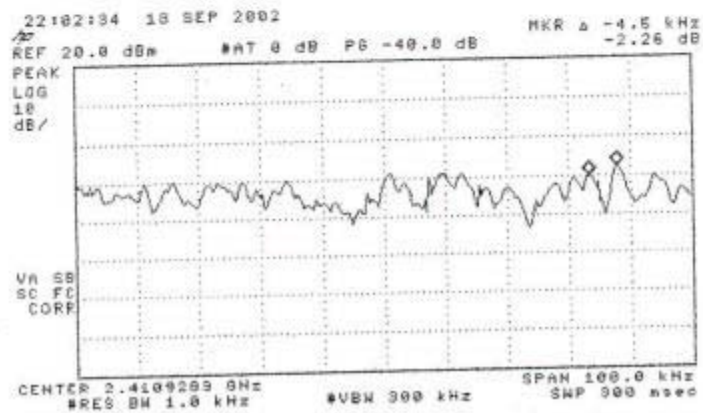
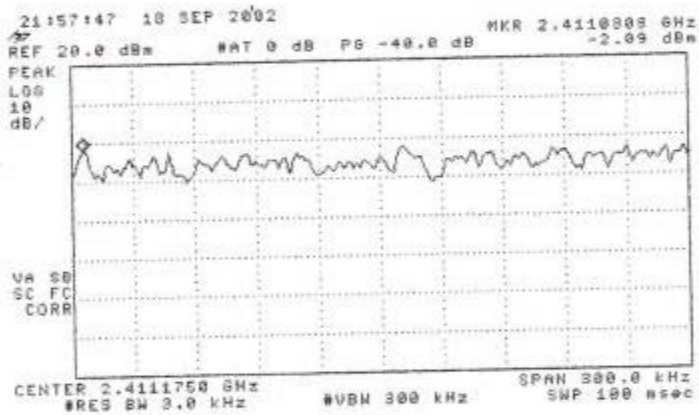
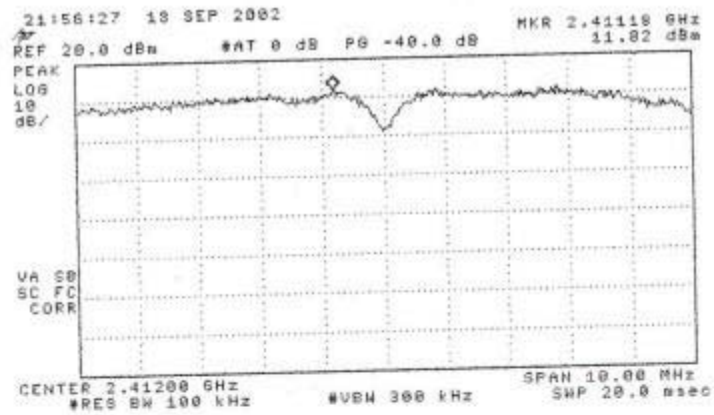

Figure 6.5(a) Spectral Density (low channel)
 (top) Spectrum Scan, (mid) Spectral Density, (bottom) Line Spacing.
 HA2401-AGC-250 Amplifier (250 mW)

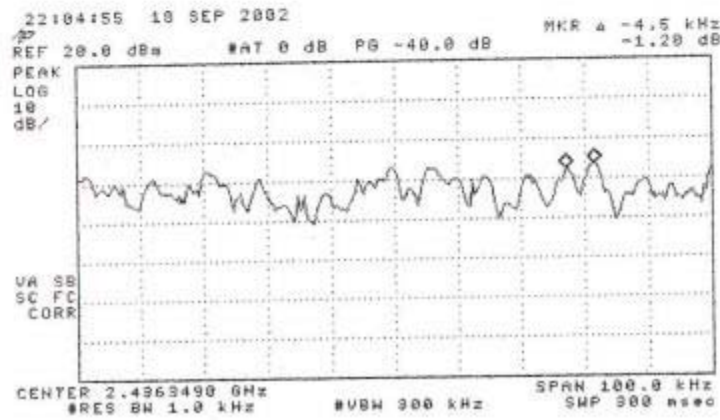
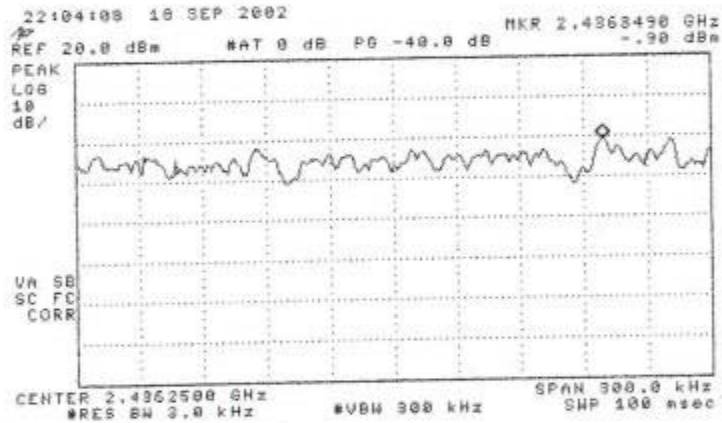
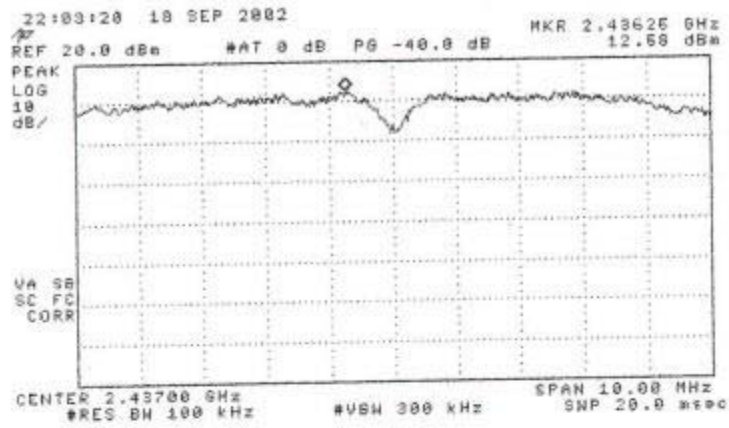

Figure 6.5(b) Spectral Density (high channel)
 (top) Spectrum Scan, (mid) Spectral Density, (bottom) Line Spacing.
 HA2401-AGC-250 Amplifier (250 mW)

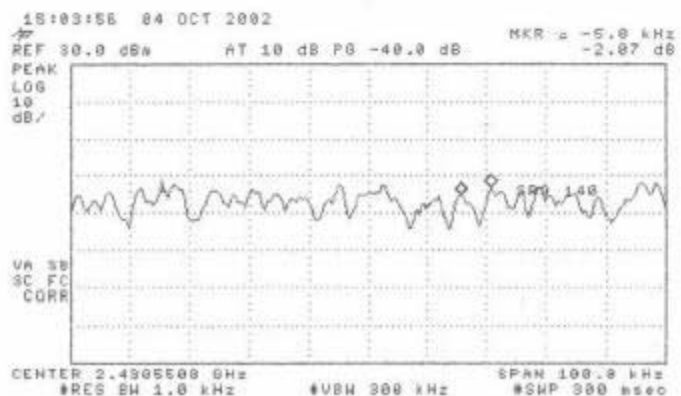
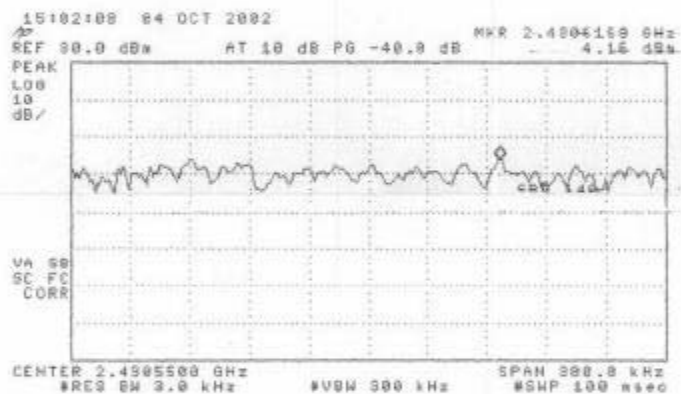
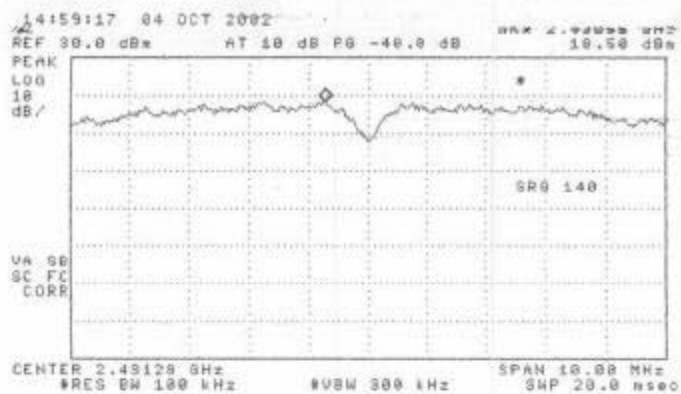

Figure 6.6(a) Spectral Density (low channel)
 (top) Spectrum Scan, (mid) Spectral Density, (bottom) Line Spacing.
 HA2401-AGC1000 Amplifier (1000 mW)

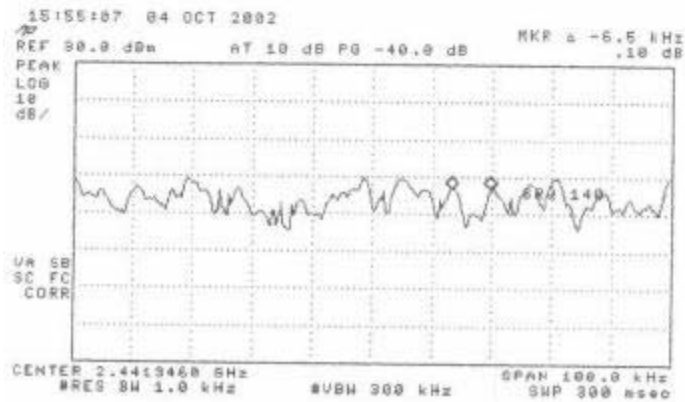
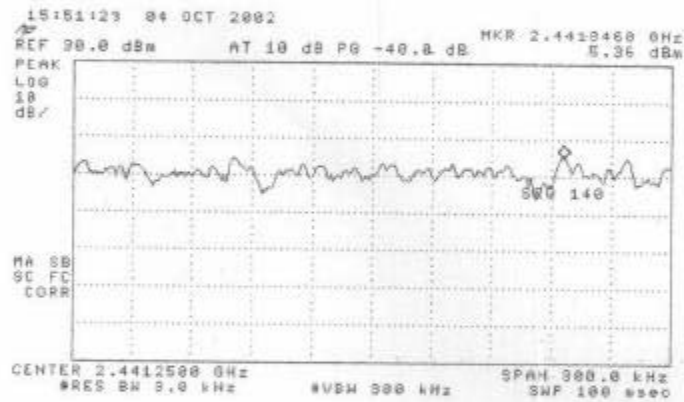
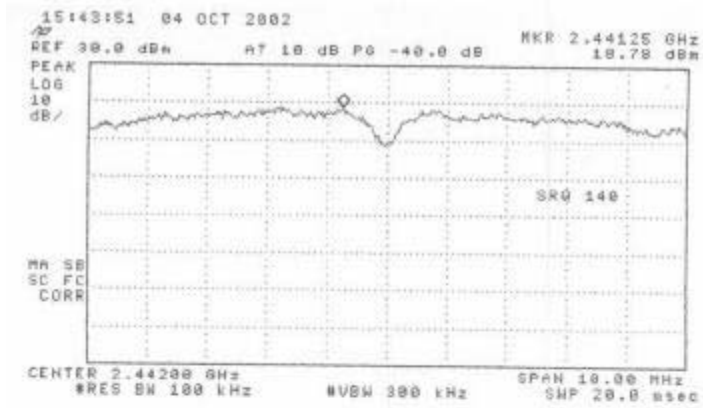

Figure 6.6(b) Spectral Density (high channel)
 (top) Spectrum Scan, (mid) Spectral Density, (bottom) Line Spacing.
 HA2401-AGC1000 Amplifier (1000 mW)

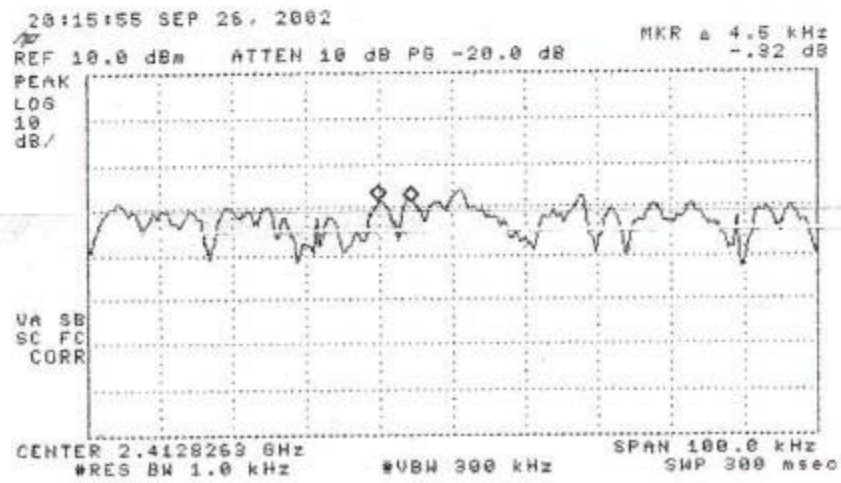
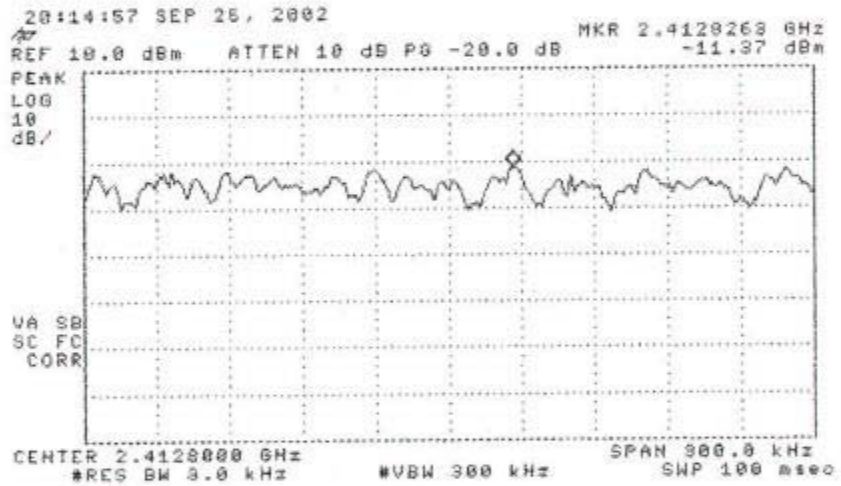
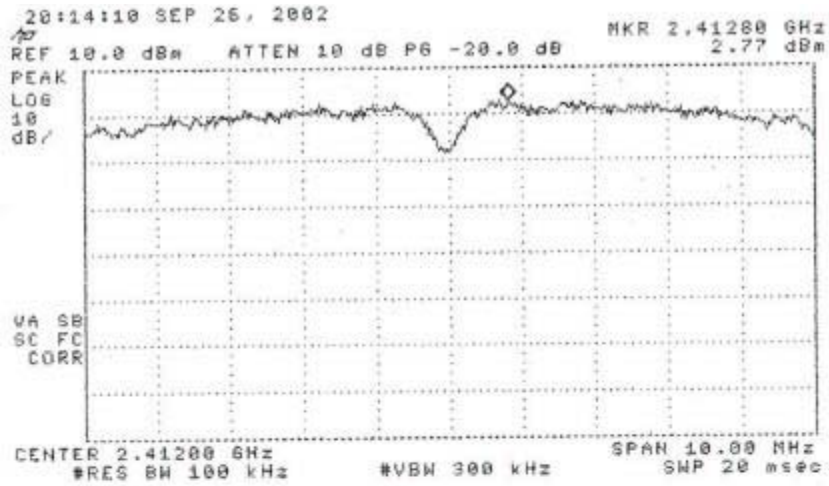

Figure 6.7(a) Spectral Density (low channel)
 (top) Spectrum Scan, (mid) Spectral Density, (bottom) Line Spacing.
 Radio Alone (No Amplifier)

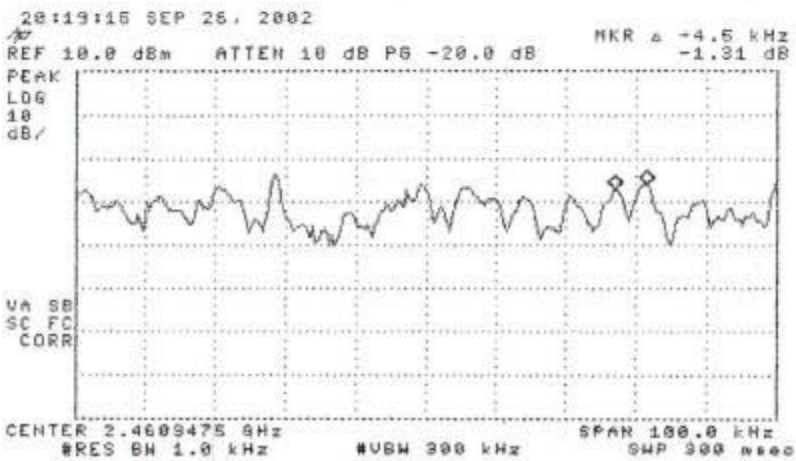
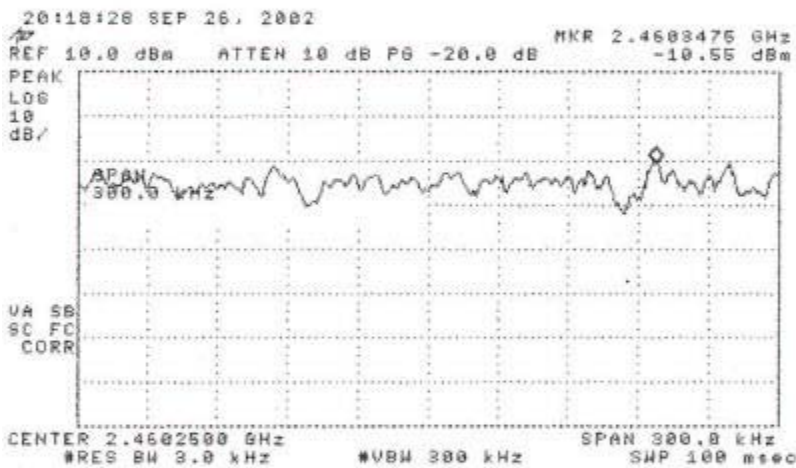
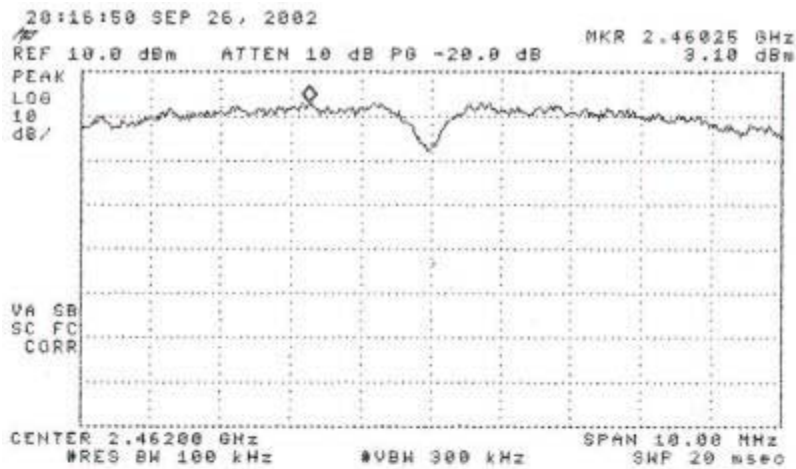

Figure 6.7(b) Spectral Density (high channel)
(top) Spectrum Scan, (mid) Spectral Density, (bottom) Line Spacing.
Radio Alone (No Amplifier)