

User Manual

**Model HA2401-G11FNFPCX
FCC ID: MYF-G11FNFPCX
IC: 2837A-G11FNFPCX**

Interference Statement

This device complies with Part 15 of the FCC Rules and with RSS-210 of Industry Canada. Operation is subject to the following two conditions: (1) this device may not cause harmful interference, and (2) this device must accept any interference received, including interference that may cause undesired operation.

Warning: Changes or modifications not expressly approved by the party responsible for compliance could void the user's authority to operate the equipment.

The term "IC:" before the radio certification number only signifies that Industry Canada technical specifications were met.

NOTE: This system must be installed by experienced professional installers who are familiar with radio frequency (RF) equipment operation as well as local building and safety codes. Failure to do so may void the Product Warranty, as well as expose the end-user to legal and/or financial liabilities.

Information to the user

NOTE: This equipment has been tested and found to comply with the limits for a Class B digital device, pursuant to Part 15 of the FCC Rules. These limits are designed to provide reasonable protection against harmful interference in a residential installation. This equipment generates, uses, and can radiate radio frequency energy. If not installed and used in accordance with the instructions, it may cause harmful interference to radio communications. However, there is no guarantee that interference will not occur in a particular installation. If this equipment does cause harmful interference to radio or television reception, which can be determined by turning the equipment off and on, the user is encouraged to try and correct the interference by one or more of the following measures:

Reorient or relocate the receiving antenna.

Increase the distance between the equipment and the receiver.

Connect the equipment to an outlet on a circuit different from that to which the receiver is connected.

Consult the dealer or an experienced radio/TV technician for help.

Any changes or modifications of equipment not expressly approved by the manufacturer could void the user's authority to operate the equipment and the company's warranty.

NOTE: Certain high gain antennas are intended for point-to-point or point-to-multipoint applications only. These antennas are clearly identified in the table contained in this manual. Note that +36 dBi may only be exceeded for point-to-point applications as given in 15.247(b). It is the installers responsibility that when using these antennas to ensure that the system is used exclusively for point-to-point operations, and that the antenna may not be co-located with other intentional radiators transmitting the same information". The device and its antenna and must not be co-located or operating in conjunction with any other antenna or transmitter.

The table contained in this manual identifies which antennas are considered "fixed" and which are "mobile". When this device is installed as a fixed-mount application there is a minimum required separation distance of one hundred (100) cm between the antenna and all persons during normal operation. All mobile antennas must be mounted at a minimum distance of 20 cm from users.

AP Installation:

Conduct a Site Survey to determine the best location for the system. Once located, install the Enclosure in an appropriate location. Follow the enclosure mounting instructions for specific mounting and grounding details.

Mount the AP Mounting Bracket to the mounting plate in the enclosure using the (3) screws provided. Refer to the figure below for proper positioning.

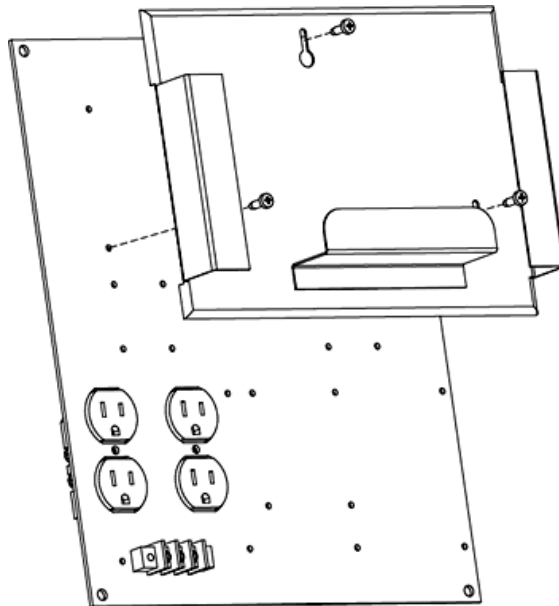

Attach the AC Power Cord to the Power Supply and clip the AP Power Supply into the base of the AP Mounting Bracket. Slide the AP module onto the mounting bracket. Make sure it is properly seated.

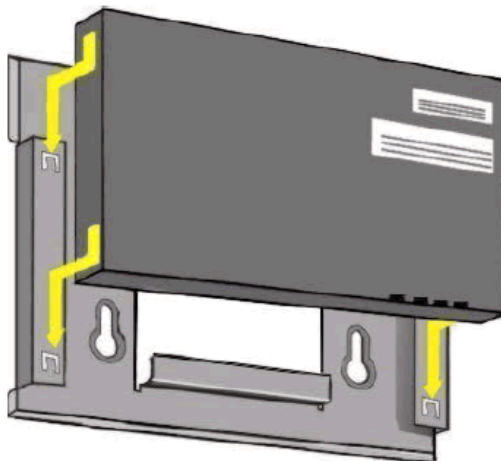

Slide the PC Card into either Slot A or Slot B.

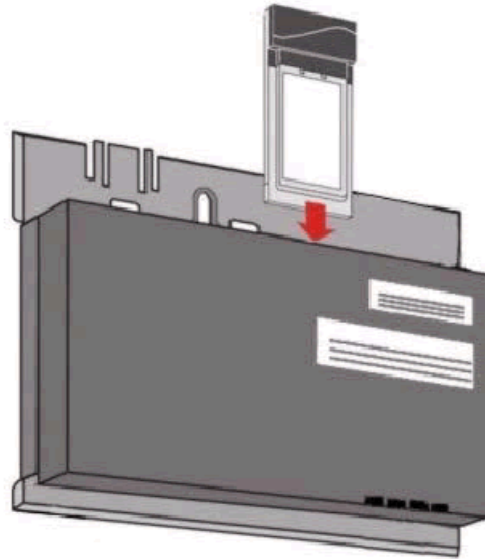

Mount the amplifier into the enclosure as shown in below:

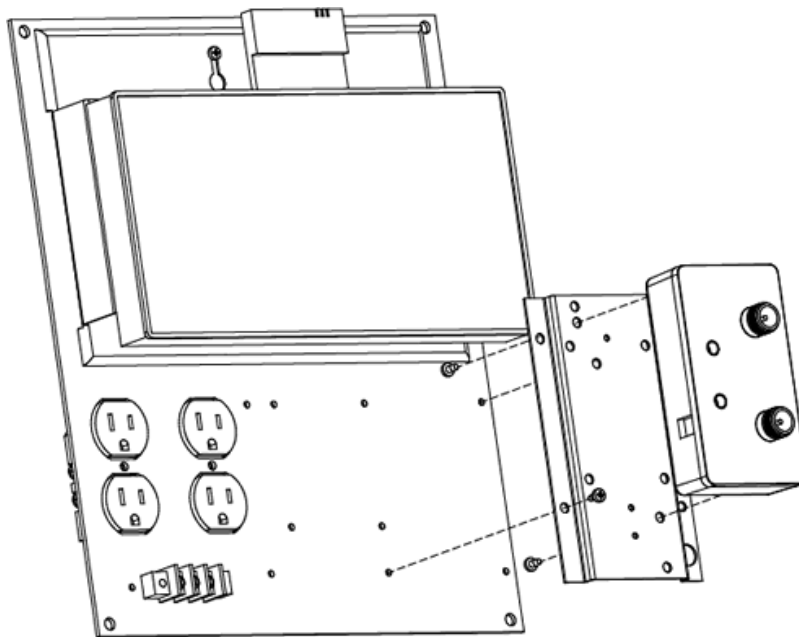

Connect the Pigtail Cable between the PC Card and the Amplifier input. Connect the amplifier output to the Filter/ Lightning Protector, as required (see Appendix A).

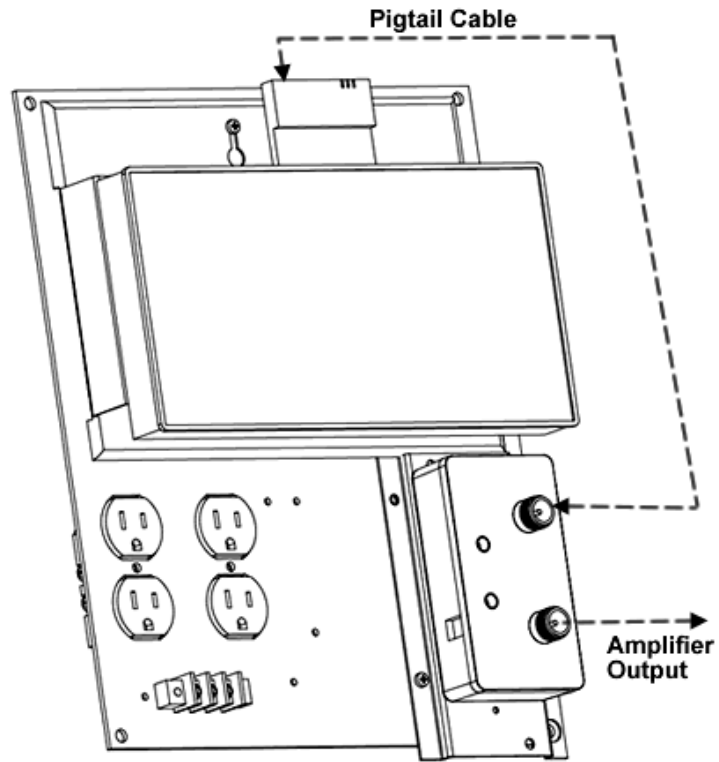

Install the Antenna

NOTE: THE ANTENNA SYSTEM SHALL BE INSTALLED ONLY BY EXPERIENCED ANTENNA INSTALLERS WHO ARE FAMILIAR WITH LOCAL BUILDING AND SAFETY CODES, AND WHEREVER NECESSARY HAVE BEEN LICENSED BY APPROPRIATE GOVERNMENT REGULATORY BODIES. FAILURE TO DO SO MAY VOID THE PRODUCT WARRANTY, AS WELL AS EXPOSE THE END-USER TO LEGAL AND/OR FINANCIAL LIABILITIES. HYPERLINK TECHNOLOGIES, ITS AGENTS, RESELLERS OR DISTRIBUTORS, ARE NOT LIABLE FOR INJURY, DAMAGE, OR VIOLATION OF GOVERNMENT REGULATIONS THAT MAY ARISE FROM FAILING TO COMPLY WITH THE GUIDELINES DESCRIBED IN THIS DOCUMENT.

Mount the antenna according to the specific installation instructions for the model you are installing. When choosing the antenna site you must observe the following exposure limits:

The table contained in Appendix A of this manual identifies which antennas are considered “fixed” and which are “mobile”. When this device is installed as a fixed-mount application there is a minimum required separation distance of one hundred (100) cm between the antenna and all persons during normal operation. All mobile antennas must be mounted at a minimum distance of 20 cm from users.

Once the antenna is installed connect the antenna to the amplifier and signal filter (as applicable) using the antenna cable.

Connect the Ethernet cable to the AP. For configuration, use an Ethernet crossover and connect directly to a PC.

Apply power to the Access Point unit. Check the diagnostic lights to ensure proper connection.

You should now be ready to configure the Access Point.

Use the Scan Tool to determine the MAC and IP Address for the AP

Install the Scan Tool program on the PC you will be using to configure the AP over the Ethernet segment.

Run the Scan Tool to determine the MAC Address and default IP Address for the AP.

You can use the Change Screen to change the IP Address, Subnet Mask and Gateway IP Address as required.

For more detailed information about installing and running the Scan Tool, refer to the AP-2000 User Guide.

Configure the AP's Basic Wireless Operations Settings

The first time you connect to the AP using the HTTP interface, the Setup Wizard launches automatically. It provides instructions for how to configure the Access Point's basic operating parameter including Network Name, IP Parameters, RF Parameters, System Parameters and Management Passwords.

To access the setup screens, first open a Web browser on the configuration PC. It may be necessary to disable the browser's Internet Proxy Settings if set. Enter the IP Address of the AP in the browser's address line and press Enter.

When the Security screen appears you will need to log in. Leave the User Name blank. The default login password is *public*.



Enter Network Password

Please type your user name and password.

Site: 192.168.0.3

Realm: Access-Product

User Name:

Password:

Save this password in your password list

OK Cancel

Using the configuration screens configure the basic operating parameters below:

Network Name (SSID): Enter a Network Name (between 2 and 31 characters long) for the wireless network.

Auto Channel Select: You must disable this feature in order to manually set the operating channel.

Frequency Channel: Select an authorized frequency channel based upon the specific antenna used from the table in Appendix A.

Transmit Rate: Use the drop-down menu to select the **Auto-Fallback** option.

WEP Encryption: Place a check mark in the box provided to enable WEP encryption. See WEP Encryption in the AP-2000 User Guide for more information about WEP and Encryption Keys.

Set Encryption Key 1: If you enable Encryption, configure an Encryption Key. See WEP Encryption in the AP-2000 User Guide for more information about WEP and Encryption Keys.

Note: Additional advanced settings are available in the Wireless Interface Configuration screen. See the Wireless (802.11b/g) Configuration information in the AP-2000 User Guide for more information.

Review the Configuration Summary. If you want to make any additional changes, use the navigation panel on the left-hand side of the screen to return to an earlier screen. After making a change, click Save & Next to save the change and proceed to the next screen.

When finished click Reboot on the Summary screen to restart the AP and apply your changes.

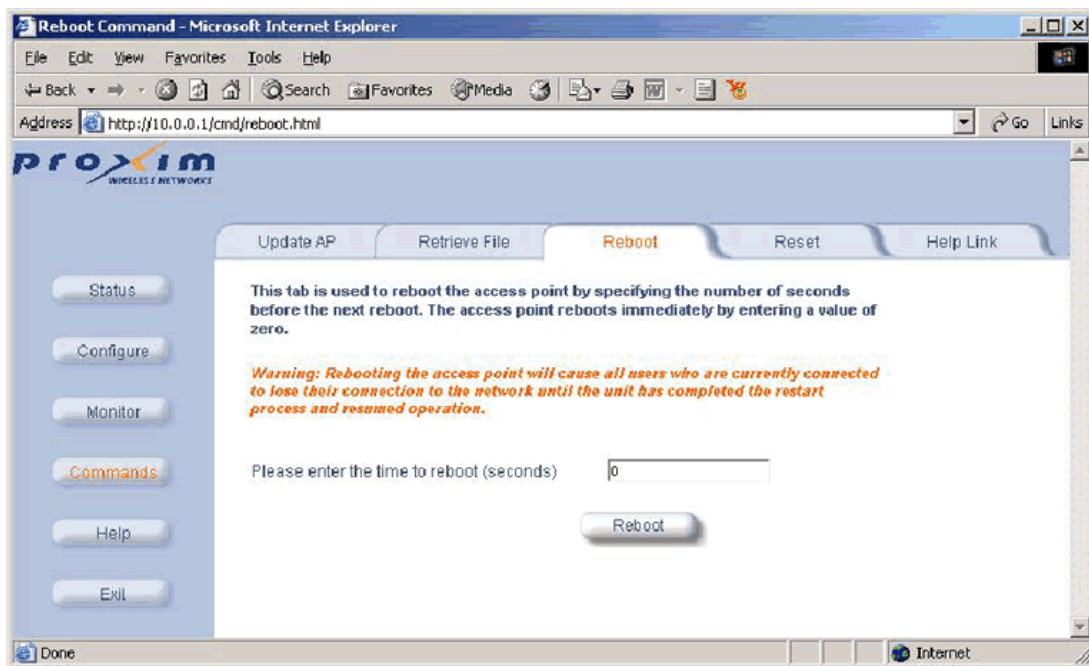

Setting and Changing Security Passwords

Note: Configure the following passwords by entering a password in both the **Password** field and the **Confirm** field:

SNMP Read Password – The password for read access to the AP using SNMP.

SNMP Read-Write Password – The password for read and write access to the AP using SNMP.

SNMPv3 Authentication Password – The password used when sending authenticated SNMPv3 messages. Secure Management (Services Tab) must be enabled in order to configure SNMPv3.

SNMPv3 Privacy Password - The password used when sending encrypted SNMPv3 data. Secure Management (Services Tab) must be enabled in order to configure SNMPv3.

Telnet (CLI) Password – The password for the CLI interface (via serial or Telnet).

HTTP (Web) Password – The password for the Web browser HTTP interface.

For security purposes make sure you set ALL PASSWORDS during installation.

IP Access Table

The Management IP Access Table limits in-band management access to the IP addresses or range of IP addresses specified in the table. This feature applies to all management options (SNMP, HTTP, and CLI) except for CLI management over the serial port. To configure this table, enter the IP Addresses and IP Masks for the desired addresses or range of addresses. Refer to the AP-2000 User Guide for further information.

Configuring WEP and WPA

Each wireless interface can be configured to operate in WEP Encryption mode, 802.1x Security Mode, Mixed (802.1x and WEP) Mode, WPA Mode and WPA-PSK (Pre-shared Key) Mode. The Security mode selection is accessed through the Advanced Configuration menus. Refer to the AP-2000 User Guide for further information.

Once the AP settings have been configured, apply power to the amplifier by plugging in the appropriate DC power supply. Check the diagnostic LEDs to ensure proper connection.

Running the Link Test Utility

You should now be ready to align the antenna using the Link Test utility. During the Link Test, the Access Point and a selected Test Partner device exchange a series of packets to test the strength and quality of the wireless connection. The Link Test utility tab is accessible from the Monitor option.

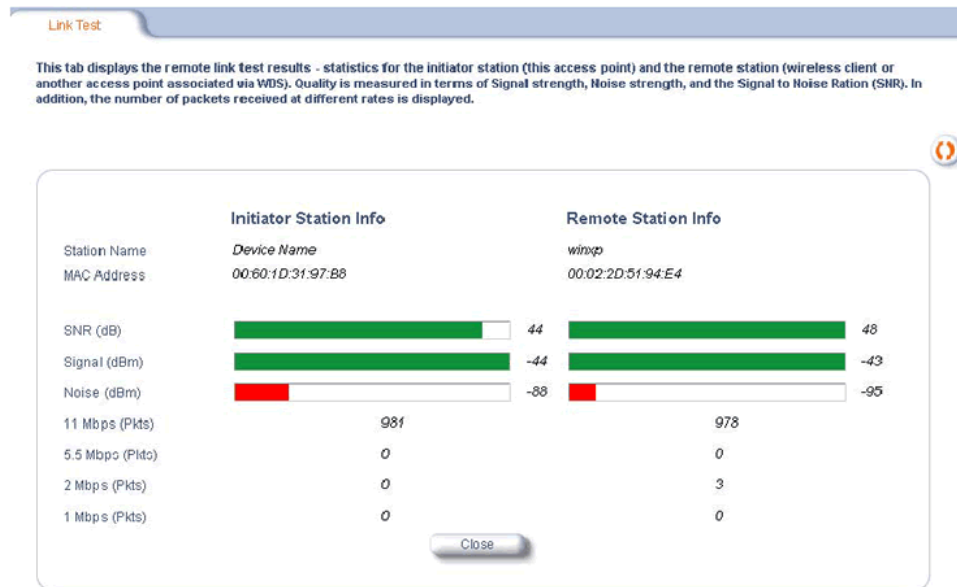

Advanced Network Settings

The system should now be ready for advanced network configuration parameters. For more information about the Advanced Network Settings, refer to the AP-2000 User Guide.

Appendix A

For Amplifier(s): HA2401GXI-XXX, HA2401GX-XXX, where XXX stands for the amplifier power rating labeled in mW (see below)

FCC / IC Compliant Configurations - Channels of Operation

Antenna Model	Antenna Type	Gain (dBi)	Amplifier Power Rating								Card Alone	
			1000 29.1	800 29	630 28	500 27	400 26	250 24	100 20	65 18.1	17.5	
HG2401U	whip/monopole	1	4-8	4-8	4-8	4-8	4-8	4-8	4-8	4-8	4-8	-
HG2402RD	whip/monopole	2	4-8	4-8	4-8	4-8	4-8	4-8	4-8	4-8	4-8	-
HG2403RD	whip/monopole	3	4-8	4-8	4-8	4-8	4-8	4-8	4-8	4-8	4-8	-
HG2403UR	whip/monopole	3	4-8	4-8	4-8	4-8	4-8	4-8	4-8	4-8	4-8	-
HG2404CU	whip/monopole	3	4-8	4-8	4-8	4-8	4-8	4-8	4-8	4-8	4-8	-
RE05E	whip/monopole	5	4-8	4-8	4-8	4-8	4-8	4-8	4-8	4-8	4-8	-
RE05U	whip/monopole	5	4-8	4-8	4-8	4-8	4-8	4-8	4-8	4-8	4-8	1-11
HG2405	whip/monopole	5	4-8	4-8	4-8	4-8	4-8	4-8	4-8	4-8	4-8	-
HG2406U	whip/monopole	6	4-8	4-8	4-8	4-8	4-8	4-8	4-8	4-8	4-8	-
HG2407U	whip/monopole	7	4-8	4-8	4-8	4-8	4-8	4-8	4-8	4-8	4-8	-
HG2408U	whip/monopole	8	N/A	4-8	4-8	4-8	4-8	4-8	4-8	4-8	4-8	-
HG2409U	whip/monopole	8.5	N/A	4-8	4-8	4-8	4-8	4-8	4-8	4-8	4-8	-
HGV-2409U	whip/monopole	8.5	N/A	4-8	4-8	4-8	4-8	4-8	4-8	4-8	4-8	-
HG2410U	whip/monopole	10	N/A	N/A	4-8	4-8	4-8	4-8	4-8	4-8	4-8	-
HG2412U	whip/monopole	12	N/A	N/A	N/A	4-8	4-8	4-8	4-8	4-8	4-8	-
HG2415U-PRO	whip/monopole	15	N/A	N/A	N/A	N/A	4-8	4-8	4-8	4-8	4-8	-
HG2409P	patch	8	N/A	4-6	4-6	4-6	4-6	4-6	4-6	4-6	4-6	-
HG2408P	patch	8	N/A	4-6	4-6	4-6	4-6	4-6	4-6	4-6	4-6	-
HG2412P	patch	12	N/A	N/A	4-6	4-6	4-6	4-6	4-6	4-6	4-6	-
HG2414P	patch	14	N/A	N/A	N/A	4-6	4-6	4-6	4-6	4-6	4-6	-
HG2416P	patch	16	N/A	N/A	N/A	N/A	4-6	4-6	4-6	4-6	4-6	-
HG2409Y	Yagi-Uda	9	N/A	4-8	4-8	4-8	4-8	4-8	4-8	4-8	4-8	-
HG2412Y	Yagi-Uda	12	N/A	N/A	4-8	4-8	4-8	4-8	4-8	4-8	4-8	-
HG2415Y	Yagi-Uda	14.5	N/A	N/A	N/A	4-8	4-8	4-8	4-8	4-8	4-8	-
HG2424G	dish	24	N/A	N/A	N/A	N/A	N/A	4	4	4	4	-

(mW) - as labeled
(dBm)

Channel	Frequency (MHz)
1	2412
2	2417
3	2422
4	2427
5	2432
6	2437
7	2442
8	2447
9	2452
10	2457
11	2462

Configurations in BLACK can be used in either MOBILE OR FIXED MOUNTED Installations (FILTER REQUIRED)

Configurations in BLUE can be used in either MOBILE OR FIXED MOUNTED Installations (NO FILTER REQUIRED)

Configurations in RED can only be used in FIXED MOUNTED Installations (FILTER REQUIRED)

Configurations with N/A are NOT PERMISSIBLE, via. FCC 15.247(b)(4)(i)

Configurations with "-" are NOT PERMISSIBLE as they do not meet the FCC Part 15 restricted band limits

Minimum Separation Distance (cm)

Antenna Model	Gain (dBi)	Amplifier Power Rating (dB)								Card Alone 17.5
		29.1	29	28	27	26	24	20	18.1	
HG2401U	1	9.0	8.9	8.0	7.1	6.3	5.0	3.2	2.5	-
HG2402RD	2	10.1	10.0	8.9	8.0	7.1	5.6	3.6	2.9	-
HG2403RD	3	11.4	11.2	10.0	8.9	8.0	6.3	4.0	3.2	-
HG2403UR	3	11.4	11.2	10.0	8.9	8.0	6.3	4.0	3.2	-
HG2404CU	3	11.4	11.2	10.0	8.9	8.0	6.3	4.0	3.2	-
RE05E	5	14.3	14.1	12.6	11.2	10.0	8.0	5.0	4.0	-
RE05U	5	14.3	14.1	12.6	11.2	10.0	8.0	5.0	4.0	3.8
HG2405	5	14.3	14.1	12.6	11.2	10.0	8.0	5.0	4.0	-
HG2406U	6	16.0	15.9	14.1	12.6	11.2	8.9	5.6	4.5	-
HG2407U	7	18.0	17.8	15.9	14.1	12.6	10.0	6.3	5.1	-
HG2408U	8	N/A	20.0	17.8	15.9	14.1	11.2	7.1	5.7	-
HG2409U	8.5	N/A	21.2	18.9	16.8	15.0	11.9	7.5	6.0	-
HGV-2409U	8.5	N/A	21.2	18.9	16.8	15.0	11.9	7.5	6.0	-
HG2410U	10	N/A	N/A	22.4	20.0	17.8	14.1	8.9	7.2	-
HG2412U	12	N/A	N/A	N/A	25.1	22.4	17.8	11.2	9.0	-
HG2415U-PRO	15	N/A	N/A	N/A	N/A	31.7	25.1	15.9	12.7	-
HG2409P	8	N/A	20.0	17.8	15.9	14.1	11.2	7.1	5.7	-
HG2408P	8	N/A	20.0	17.8	15.9	14.1	11.2	7.1	5.7	-
HG2412P	12	N/A	N/A	28.2	25.1	22.4	17.8	11.2	9.0	-
HG2414P	14	N/A	N/A	N/A	31.7	28.2	22.4	14.1	11.4	-
HG2416P	16	N/A	N/A	N/A	N/A	35.5	28.2	17.8	14.3	-
HG2409Y	9	N/A	22.4	20.0	17.8	15.9	12.6	8.0	6.4	-
HG2412Y	12	N/A	N/A	28.2	25.1	22.4	17.8	11.2	9.0	-
HG2415Y	14.5	N/A	N/A	N/A	33.5	29.9	23.7	15.0	12.0	-
HG2424G	24	N/A	N/A	N/A	N/A	N/A	70.9	44.7	35.9	-

Configurations in BLACK Can be used in either MOBILE OR FIXED MOUNTED Installations

Configurations in RED can only be used in FIXED MOUNTED Installations

Configurations with N/A are not permissible, via. FCC 15.247(b)(4)(i)

RF Exposure (mW/cm^2)

Antenna Model	Gain (dBi)	Amplifier Power Rating (dBm)								Card Alone 17.5
		29.1	29	28	27	26	24	20	18.1	
HG2401U	1	0.204	0.199	0.158	0.126	0.100	0.063	0.025	0.016	-
HG2402RD	2	0.256	0.250	0.199	0.158	0.126	0.079	0.032	0.020	-
HG2403RD	3	0.323	0.315	0.250	0.199	0.158	0.100	0.040	0.026	-
HG2403UR	3	0.323	0.315	0.250	0.199	0.158	0.100	0.040	0.026	-
HG2404CU	3	0.323	0.315	0.250	0.199	0.158	0.100	0.040	0.026	-
RE05E	5	0.511	0.500	0.397	0.315	0.250	0.158	0.063	0.041	-
RE05U	5	0.511	0.500	0.397	0.315	0.250	0.158	0.063	0.041	0.035
HG2405	5	0.511	0.500	0.397	0.315	0.250	0.158	0.063	0.041	-
HG2406U	6	0.644	0.629	0.500	0.397	0.315	0.199	0.079	0.051	-
HG2407U	7	0.810	0.792	0.629	0.500	0.397	0.250	0.100	0.064	-
HG2408U	8	N/A	0.997	0.792	0.629	0.500	0.315	0.126	0.081	-
HG2409U	8.5	N/A	0.045	0.889	0.706	0.561	0.354	0.141	0.091	-
HGV-2409U	8.5	N/A	0.045	0.889	0.706	0.561	0.354	0.141	0.091	-
HG2410U	10	N/A	N/A	0.050	0.997	0.792	0.500	0.199	0.128	-
HG2412U	12	N/A	N/A	N/A	0.063	0.050	0.792	0.315	0.204	-
HG2415U-PRO	15	N/A	N/A	N/A	N/A	0.100	0.063	0.629	0.406	-
HG2409P	8	N/A	0.997	0.792	0.629	0.500	0.315	0.126	0.081	-
HG2408P	8	N/A	0.997	0.792	0.629	0.500	0.315	0.126	0.081	-
HG2412P	12	N/A	N/A	0.080	0.063	0.050	0.792	0.315	0.204	-
HG2414P	14	N/A	N/A	N/A	0.100	0.080	0.050	0.500	0.323	-
HG2416P	16	N/A	N/A	N/A	N/A	0.126	0.080	0.792	0.511	-
HG2409Y	9	N/A	0.050	0.997	0.792	0.629	0.397	0.158	0.102	-
HG2412Y	12	N/A	N/A	0.080	0.063	0.050	0.792	0.315	0.204	-
HG2415Y	14.5	N/A	N/A	N/A	0.112	0.089	0.056	0.561	0.362	-
HG2424G	24	N/A	N/A	N/A	N/A	N/A	0.502	0.200	0.129	-

Configurations in BLACK Can be used in either MOBILE OR FIXED MOUNTED Installations (RF Exposure computed at 20 cm distance)

Configurations in RED can only be used in FIXED MOUNTED Installations (RF Exposure computed at 100 cm distance)

Configurations with N/A are not permissible, via. FCC 15.247(b)(4)(i)

Important Information

Your wireless system has been installed and configured by an RF professional to comply with FCC Part 15 regulations. These limits are designed to provide reasonable protection against harmful interference when the equipment is operated in a commercial environment. This equipment generates, uses and can radiate radio frequency energy and, if not installed and used in accordance with the installation and configuration manual, may cause harmful interference to radio communications. Operation of this equipment in a residential area is likely to cause harmful interference in which case the end user will be required to correct the interference at their own expense.

Modifications to this system including changing the antenna, power setting or transmit channel may result in a non-compliant system, and should only be undertaken by professional installers after reading the Installation Guide for this system.

For further information contact:

Hyperlink Technologies
Technical Support Dept.
1201 Clint Moore Road
Boca Raton, FL 33487
Email: support@hyperlinktech.com

SAFETY NOTICE

This equipment complies with FCC radiation exposure limits set forth for an uncontrolled environment when installed as directed. When this device is installed as a fixed-mount application there is a minimum required separation distance of one hundred (100) cm between the antenna and all persons during normal operation. For mobile mounted antennas, the required separation distance is a minimum of twenty (20) cm between the antenna and all persons during normal use.

Installer: Please post this notice in a prominent location near the transmitter.