



A D T

FCC TEST REPORT (PART 27)

REPORT NO.: RF990802C25-1

MODEL NO.: WIXFBR-117

FCC ID: MXFWIXFBR-117

RECEIVED: Aug. 02, 2010

TESTED: Aug. 17 ~ Aug. 30, 2010

ISSUED: Sep. 02, 2010

APPLICANT: Gemtek Technology Co., Ltd.

ADDRESS: No. 15-1, Zhonghua Rd, Hsinchu Industrial Park,
Hsinchu County, Taiwan, R.O.C. 303

ISSUED BY: Bureau Veritas Consumer Products Services (H.K.)
Ltd., Taoyuan Branch

LAB ADDRESS: No. 47, 14th Ling, Chia Pau Tsuen, Lin Kou Hsiang,
Taipei Hsien 244, Taiwan, R.O.C.

TEST LOCATION: No. 19, Hwa Ya 2nd Rd, Wen Hwa Tsuen, Kwei
Shan Hsiang, Taoyuan Hsien 333, Taiwan, R.O.C.

This test report consists of 61 pages in total. It may be duplicated completely for legal use with the approval of the applicant. It should not be reproduced except in full, without the written approval of our laboratory. The client should not use it to claim product certification, approval, or endorsement by TAF or any government agency. The test results in the report only apply to the tested sample.





TABLE OF CONTENTS

1	CERTIFICATION.....	4
2	SUMMARY OF TEST RESULTS	5
2.1	MEASUREMENT UNCERTAINTY.....	5
3	GENERAL INFORMATION.....	6
3.1	GENERAL DESCRIPTION OF EUT	6
3.2	DESCRIPTION OF TEST MODES	7
3.2.1	CONFIGURATION OF SYSTEM UNDER TEST	7
3.2.2	TEST MODE APPLICABILITY AND TESTED CHANNEL DETAIL	8
3.3	GENERAL DESCRIPTION OF APPLIED STANDARDS	10
3.4	DESCRIPTION OF SUPPORT UNITS	10
4	TEST TYPES AND RESULTS	11
4.1	OUTPUT POWER MEASUREMENT	11
4.1.1	LIMITS OF OUTPUT POWER MEASUREMENT	11
4.1.2	TEST INSTRUMENTS.....	11
4.1.3	TEST PROCEDURES	12
4.1.4	TEST SETUP	12
4.1.5	EUT OPERATING CONDITIONS	12
4.1.6	TEST RESULTS	13
4.2	FREQUENCY STABILITY MEASUREMENT.....	14
4.2.1	LIMITS OF FREQUENCY STABILITY MEASUREMENT	14
4.2.2	TEST INSTRUMENTS.....	14
4.2.3	TEST PROCEDURE.....	15
4.2.4	TEST SETUP.....	15
4.2.5	EUT OPERATING CONDITIONS	15
4.2.6	TEST RESULTS	16
4.3	EMISSION BANDWIDTH MEASUREMENT	18
4.3.1	LIMITS OF EMISSION BANDWIDTH MEASUREMENT	18
4.3.2	TEST INSTRUMENTS.....	18
4.3.3	TEST PROCEDURE.....	18
4.3.4	TEST SETUP.....	19
4.3.5	EUT OPERATING CONDITIONS	19
4.3.6	TEST RESULTS	20
4.4	CHANNEL EDGE MEASUREMENT.....	22
4.4.1	LIMITS OF CHANNEL EDGE MEASUREMENT	22
4.4.2	TEST INSTRUMENTS.....	22
4.4.3	TEST SETUP.....	22
4.4.4	TEST PROCEDURES	23
4.4.5	EUT OPERATING CONDITION.....	23
4.4.6	TEST RESULTS	24
4.5	CONDUCTED SPURIOUS EMISSIONS	30
4.5.1	LIMITS OF CONDUCTED SPURIOUS EMISSIONS MEASUREMENT.....	30
4.5.2	TEST INSTRUMENTS.....	30
4.5.3	TEST PROCEDURE.....	31
4.5.4	TEST SETUP.....	31
4.5.5	EUT OPERATING CONDITIONS	31
4.5.6	TEST RESULTS	32
4.6	RADIATED EMISSION MEASUREMENT (BELOW 1GHz).....	44
4.6.1	LIMITS OF RADIATED EMISSION MEASUREMENT.....	44
4.6.2	TEST INSTRUMENTS.....	45



A D T

4.6.3	TEST PROCEDURES	46
4.6.4	DEVIATION FROM TEST STANDARD	46
4.6.5	TEST SETUP	47
4.6.6	EUT OPERATING CONDITIONS	47
4.6.7	TEST RESULTS	48
4.7	RADIATED EMISSION MEASUREMENT (ABOVE 1GHZ)	52
4.7.1	LIMITS OF RADIATED EMISSION MEASUREMENT	52
4.7.2	TEST INSTRUMENTS	52
4.7.3	TEST PROCEDURES	52
4.7.4	DEVIATION FROM TEST STANDARD	53
4.7.5	TEST SETUP	53
4.7.6	EUT OPERATING CONDITIONS	53
4.7.7	TEST RESULTS	54
5	PHOTOGRAPHS OF THE TEST CONFIGURATION	60
6	INFORMATION ON THE TESTING LABORATORIES	61



A D T

1 CERTIFICATION

PRODUCT: 2.5GHz WiMAX/WiFi CPE

MODEL: WIXFBR-117

BRAND: CLEARWIRE

APPLICANT: Gemtek Technology Co., Ltd.

TEST SAMPLE: ENGINEERING SAMPLE

TESTED: Aug. 17 ~ Aug. 30, 2010

TEST STANDARDS: FCC Part 27, Subpart C & M

The above equipment (Model: WIXFBR-117) has been tested by **Bureau Veritas Consumer Products Services (H.K.) Ltd., Taoyuan Branch**, and found compliance with the requirement of the above standards. The test record, data evaluation & Equipment Under Test (EUT) configurations represented herein are true and accurate accounts of the measurements of the sample's EMC characteristics under the conditions specified in this report.

PREPARED BY : Andrea Hsia , **DATE** : Sep. 02, 2010
Andrea Hsia / Specialist

TECHNICAL ACCEPTANCE : Long Chen , **DATE** : Sep. 02, 2010
Responsible for RF Long Chen / Senior Engineer

APPROVED BY : Gary Chang , **DATE** : Sep. 02, 2010
Gary Chang / Assistant Manager



2 SUMMARY OF TEST RESULTS

The EUT has been tested according to the following specifications:

STANDARD SECTION	TEST TYPE AND LIMIT	RESULT	REMARK
FCC Part 27 & Part 2			
2.1046 27.50(h)(2)	Maximum Peak Output Power Limit: max. 2 Watt.	PASS	Meet the requirement of limit. Minimum passing margin is 27.07dBm at 2687.5MHz.
2.1055 27.54	Frequency Stability Stay with the authorized bands of operation	PASS	Meet the requirement of limit.
2.1049 27.53(m)(6)	Emission Bandwidth	PASS	Meet the requirement of limit.
2.1051 27.53(m)(4)(6)	Band Edge Measurements	PASS	Meet the requirement of limit.
2.1051 27.53(m)(4)(6)	Conducted Spurious Emissions	PASS	Meet the requirement of limit.
2.1053 27.53(m)(4)(6)	Radiated Spurious Emissions	PASS	Meet the requirement of limit. Minimum passing margin is -2.8dB at 8062.5MHz.

2.1 MEASUREMENT UNCERTAINTY

Where relevant, the following measurement uncertainty levels have been estimated for tests performed on the EUT as specified in CISPR 16-4-2:

MEASUREMENT	FREQUENCY	UNCERTAINTY
Conducted emissions	9kHz~30MHz	2.44 dB
Radiated emissions	30MHz ~ 200MHz	3.19 dB
	200MHz ~ 1000MHz	3.21 dB
	1GHz ~ 18GHz	2.26 dB
	18GHz ~ 40GHz	1.94 dB

This uncertainty represents an expanded uncertainty expressed at approximately the 95% confidence level using a coverage factor of $k = 2$.



3 GENERAL INFORMATION

3.1 GENERAL DESCRIPTION OF EUT

EUT	2.5GHz WiMAX/WiFi CPE
MODEL NO.	WIXFBR-117
FCC ID	MXFWIXFBR-117
NOMINAL VOLTAGE	12Vdc
MODULATION TYPE	UL: QPSK1/2, QPSK 3/4, 16QAM1/2, 16QAM 3/4 DL: QPSK1/2, QPSK 3/4, 16QAM1/2, 16QAM 3/4, 64QAM1/2, 64QAM2/3, 64QAM3/4, 64QAM5/6
MODULATION TECHNOLOGY	OFDMA
DUPLEX METHOD	TDD
OPERATING RANGE	2501.5MHz ~ 2687.5MHz
CHANNEL BANDWIDTH	5MHz, 10MHz
MAX. COUDUCTED POWER	27.07dBm
ANTENNA TYPE	Dipole PCB antenna with 6dBi gain
OPERATION TEMPERATURE RANGE	0°C ~ 40°C
I/O PORTS	RJ45, RJ11
DATA CABLE	2m non-shielded RJ45 cable without core
ACCESSORY DEVICES	Adapter

NOTE:

- The EUT is a 2.5GHz WiMAX/WiFi CPE. The test data are separated into following test reports.

	TEST STANDARD	REFERENCE REPORT
WLAN 802.11b/g/n	FCC Part 15, Subpart C	RF990802C25
WIMAX	FCC Part 27, Subpart C & M	RF990802C25-1

- The EUT was powered by the following adapters:

Adapter 1	
BRAND:	AMIGO
MODEL:	AMS4-1202000FU
INPUT:	100-240Vac, 50/60Hz, 0.8A
OUTPUT:	12Vdc, 2A
POWER LINE:	DC: 1500mm non-shielded cable without core

Adapter 2	
BRAND:	DVE
MODEL:	DSA-26PFA-15 FUS 120200
INPUT:	100-240Vac, 50/60Hz, 0.8A
OUTPUT:	12Vdc, 2A
POWER LINE:	DC: 1500mm non-shielded cable without core

- The EUT can supports different UL / DL ratio, max transmit ratio is up to 18 (UL): 29 (DL). After pretesting of output power and spurious emission, 18 (UL): 29 (DL) was found to be worst case and was selected for the final test configuration.
- The above EUT information was declared by manufacturer and for more detailed features description please refers to the manufacturer's specifications or User's Manual.

3.2 DESCRIPTION OF TEST MODES

Three channels had been tested for each channel bandwidth.

CHANNEL BANDWIDTH: 5MHz	CHANNEL BANDWIDTH: 10MHz
Low channel (L): 2501.5MHz.	Low channel (L): 2505MHz.
Middle channel (M): 2600.0MHz.	Middle channel (M): 2600 MHz.
High channel (H): 2687.5MHz.	High channel (H): 2685 MHz.

3.2.1 CONFIGURATION OF SYSTEM UNDER TEST

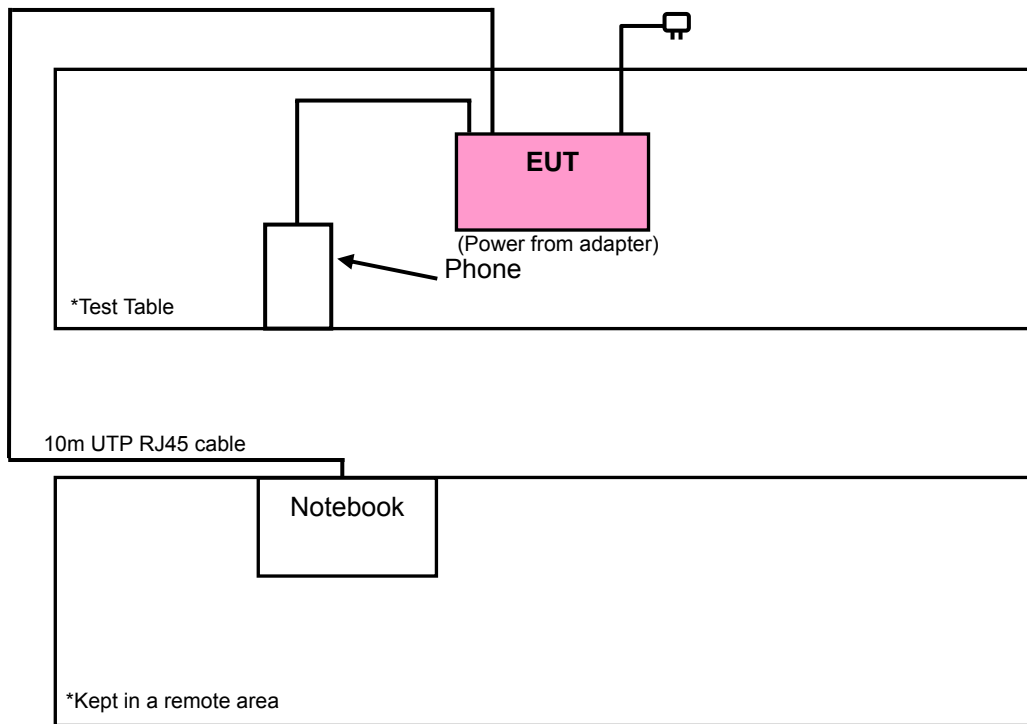



3.2.2 TEST MODE APPLICABILITY AND TESTED CHANNEL DETAIL

EUT CONFIGURE MODE	APPLICABLE TO							DESCRIPTION
	OP	FS	EB	CE	CSE	RE<1G	RE≥1G	
A	√	√	√	√	√	√	√	For Adapter 1
B	-	-	-	-	-	√	-	For Adapter 2

Where **OP**: Output power **FS**: Frequency stability
EB: Emission bandwidth **CE**: Channel edge
CSE: Conducted spurious emissions **RE<1G**: Radiated emission below 1GHz
RE≥1G: Radiated emission above 1GHz **NOTE**: "-" means no effect.

OUTPUT POWER MEASUREMENT:

- Pre-Scan has been conducted to determine the worst-case mode from all possible combinations between available modulations, data rates, XYZ axis and antenna ports (if EUT with antenna diversity architecture).
- Following channel(s) was (were) selected for the final test as listed below.

EUT CONFIGURE MODE	TESTED CHANNEL	MODULATION TECHNOLOGY	CHANNEL BANDWIDTH	MODULATION TYPE	CODING RATE
A	L, M, H	OFDMA	5MHz	QPSK	1/2
A	L, M, H	OFDMA	10MHz	QPSK	1/2

FREQUENCY STABILITY MEASUREMENT:

- Pre-Scan has been conducted to determine the worst-case mode from all possible combinations between available modulations, coding rate, and antenna ports (if EUT with antenna diversity architecture).
- Following channel(s) was (were) selected for the final test as listed below.

EUT CONFIGURE MODE	TESTED CHANNEL	MODULATION TECHNOLOGY	CHANNEL BANDWIDTH	MODULATION TYPE	CODING RATE
A	M	OFDMA	5MHz	QPSK	1/2
A	M	OFDMA	10MHz	QPSK	1/2

EMISSION BANDWIDTH MEASUREMENT:

- Pre-Scan has been conducted to determine the worst-case mode from all possible combinations between available modulations, coding rate, and antenna ports (if EUT with antenna diversity architecture).
- Following channel(s) was (were) selected for the final test as listed below.

EUT CONFIGURE MODE	TESTED CHANNEL	MODULATION TECHNOLOGY	CHANNEL BANDWIDTH	MODULATION TYPE	CODING RATE
A	L, M, H	OFDMA	5MHz	QPSK	1/2
A	L, M, H	OFDMA	10MHz	QPSK	1/2



CHANNEL EDGE MEASUREMENT:

- Pre-Scan has been conducted to determine the worst-case mode from all possible combinations between available modulations, coding rate, and antenna ports (if EUT with antenna diversity architecture).
- Following channel(s) was (were) selected for the final test as listed below.

EUT CONFIGURE MODE	TESTED CHANNEL	MODULATION TECHNOLOGY	CHANNEL BANDWIDTH	MODULATION TYPE	CODING RATE
A	L, M, H	OFDMA	5MHz	QPSK	1/2
A	L, M, H	OFDMA	10MHz	QPSK	1/2

CONDUCTED SPURIOUS EMISSIONS MEASUREMENT:

- Pre-Scan has been conducted to determine the worst-case mode from all possible combinations between available modulations, coding rate, and antenna ports (if EUT with antenna diversity architecture).
- Following channel(s) was (were) selected for the final test as listed below.

EUT CONFIGURE MODE	TESTED CHANNEL	MODULATION TECHNOLOGY	CHANNEL BANDWIDTH	MODULATION TYPE	CODING RATE
A	L, M, H	OFDMA	5MHz	QPSK	1/2
A	L, M, H	OFDMA	10MHz	QPSK	1/2

RADIATED EMISSION MEASUREMENT (BELOW 1 GHz):

- Pre-Scan has been conducted to determine the worst-case mode from all possible combinations between available modulations, coding rate, and antenna ports (if EUT with antenna diversity architecture).
- Following channel(s) was (were) selected for the final test as listed below.

EUT CONFIGURE MODE	TESTED CHANNEL	MODULATION TECHNOLOGY	CHANNEL BANDWIDTH	MODULATION TYPE	CODING RATE
A & B	M	OFDMA	5MHz	QPSK	1/2
A & B	M	OFDMA	10MHz	QPSK	1/2

RADIATED EMISSION MEASUREMENT (ABOVE 1 GHz):

- Pre-Scan has been conducted to determine the worst-case mode from all possible combinations between available modulations, data rates, XYZ axis and antenna ports (if EUT with antenna diversity architecture).
- Following channel(s) was (were) selected for the final test as listed below.

EUT CONFIGURE MODE	TESTED CHANNEL	MODULATION TECHNOLOGY	CHANNEL BANDWIDTH	MODULATION TYPE	CODING RATE
A	L, M, H	OFDMA	5MHz	QPSK	1/2
A	L, M, H	OFDMA	10MHz	QPSK	1/2



A D T

3.3 GENERAL DESCRIPTION OF APPLIED STANDARDS

The EUT is a RF product. According to the specifications of the manufacturer, it must comply with the requirements of the following standards:

FCC 47 CFR Part 2

FCC 47 CFR Part 27

ANSI/TIA/EIA-603-C-2004

3.4 DESCRIPTION OF SUPPORT UNITS

The EUT has been tested as an independent unit together with other necessary accessories or support units. The following support units or accessories were used to form a representative test configuration during the tests.

NO.	PRODUCT	BRAND	MODEL NO.	SERIAL NO.	FCC ID
1	TELEPHONE	WONDER	WD-303	5C17DA09279	NA
2	NOTEBOOK	DELL	PP05L	12130898320	E2K24CLNS

NO.	SIGNAL CABLE DESCRIPTION OF THE ABOVE SUPPORT UNITS
1	1.8m UTP RJ11 cable.
2	10m UTP RJ45 cable.

NOTE:

1. All power cords of the above support units are non shielded (1.8m).
2. Items 2 acted as communication partners to transfer data.



A D T

4 TEST TYPES AND RESULTS

4.1 OUTPUT POWER MEASUREMENT

4.1.1 LIMITS OF OUTPUT POWER MEASUREMENT

The radiated peak output power shall be according to the specific rule Part 27.50(h)(2) that “User stations are limited to 2 watts” and 27.50(i) specific that “Peak transmit power must be measure over any interval of continuous transmission using instrumentation calibration in terms of rms-equivalent voltage.”

4.1.2 TEST INSTRUMENTS

DESCRIPTION & MANUFACTURER	MODEL NO.	SERIAL NO.	DATE OF CALIBRATION	DUE DATE OF CALIBRATION
High Speed Peak Power Meter	ML2495A	0824011	Aug. 02, 2010	Aug. 01, 2011
Power Sensor	MA2411B	0738171	Aug. 02, 2010	Aug. 01, 2011

NOTE:

1. The calibration interval of the above test instruments is 12 months and the calibrations are traceable to NML/ROC and NIST/USA.
2. Measurement Bandwidth of ML2495A is 65MHz greater than 26dB bandwidth of emission.

4.1.3 TEST PROCEDURES

A power sensor was used on the output port of the EUT. A power meter was used to read the response of the power sensor. Record the power level.

4.1.4 TEST SETUP

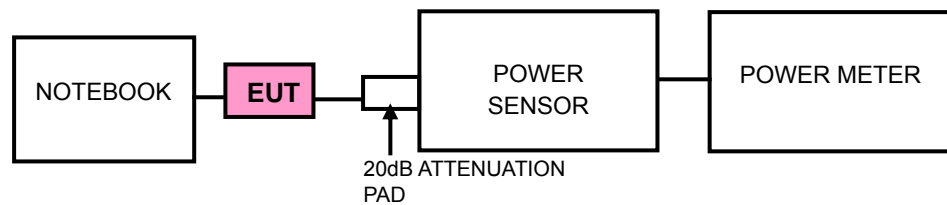

4.1.5 EUT OPERATING CONDITIONS

- a. Link up EUT with signal generator.
- b. The signal generator controlled EUT to export rated output power under transmission mode and specific channel frequency.



A D T

4.1.6 TEST RESULTS

CHANNEL BANDWIDTH: 5MHz

ENVIRONMENTAL CONDITIONS	23degoC, 62%RH 991hPa	TESTED BY	Mark Liao
---------------------------------	--------------------------	------------------	-----------

CONDUCTED POWER (RMS)					
CHANNEL	FREQUENCY (MHz)	C.F (dB)	POWER METER READING (dBm)	POWER (dBm)	POWER (W)
Low	2501.5	21.0	6.0	27.04	0.5058
Middle	2600.0	21.0	6.1	27.07	0.5093
High	2687.5	21.0	6.1	27.05	0.5070

NOTE: C.F = attenuator + cable loss

CHANNEL BANDWIDTH: 10MHz

ENVIRONMENTAL CONDITIONS	23degoC, 62%RH 991hPa	TESTED BY	Mark Liao
---------------------------------	--------------------------	------------------	-----------

CONDUCTED POWER (RMS)					
CHANNEL	FREQUENCY (MHz)	C.F (dB)	POWER METER READING (dBm)	POWER (dBm)	POWER (W)
Low	2505	21.0	5.9	26.91	0.4909
Middle	2600	21.0	6.0	26.96	0.4966
High	2685	21.0	5.9	26.94	0.4943

NOTE: C.F = attenuator + cable loss



A D T

4.2 FREQUENCY STABILITY MEASUREMENT

4.2.1 LIMITS OF FREQUENCY STABILITY MEASUREMENT

According to the FCC part 2.1055 shall be tested the frequency stability. The rule is defined that "The frequency stability shall be sufficient to ensure that the fundamental emission stays within the authorized frequency block." The test extreme voltage is according to the 2.1055(d)(1) Vary primary supply voltage from 85 to 115 percent of the nominal value for other than hand carried battery equipment and the extreme temperature rule is comply with specification of EUT $-30^{\circ}\text{C} \sim 50^{\circ}\text{C}$.

4.2.2 TEST INSTRUMENTS

DESCRIPTION & MANUFACTURER	MODEL NO.	SERIAL NO.	DATE OF CALIBRATION	DUE DATE OF CALIBRATION
Spectrum Analyzer Agilent	E4446A	MY44360124	Feb. 05, 2010	Feb. 04, 2011
RF cable	SUCOFLEX 104	257029	Sep. 12, 2009	Sep. 11, 2010
WIT Standard Temperature & Humidity Chamber	MHU-225AU	920409	May 06, 2010	May 05, 2011

NOTE: The calibration interval of the above test instruments is 12 months. And the calibrations are traceable to NML/ROC and NIST/USA.

4.2.3 TEST PROCEDURE

- a. Power must be removed when changing from one temperature to another or one voltage to another voltage. Power warm up is at least 15 min and power applied should perform before recording frequency error.
- b. EUT is connected the external power supply to control the AC input power. The various Volts from the minimum 93.5 Volts to 126.5 Volts. Each step shall be record the frequency error rate.
- c. The temperature range step is 10 degrees in this test items. All temperature levels shall be hold the $\pm 0.5^{\circ}\text{C}$ during the measurement testing.
- d. The each temperature step shall be at least 0.5 hours, consider the EUT could be test under the stability condition.

4.2.4 TEST SETUP

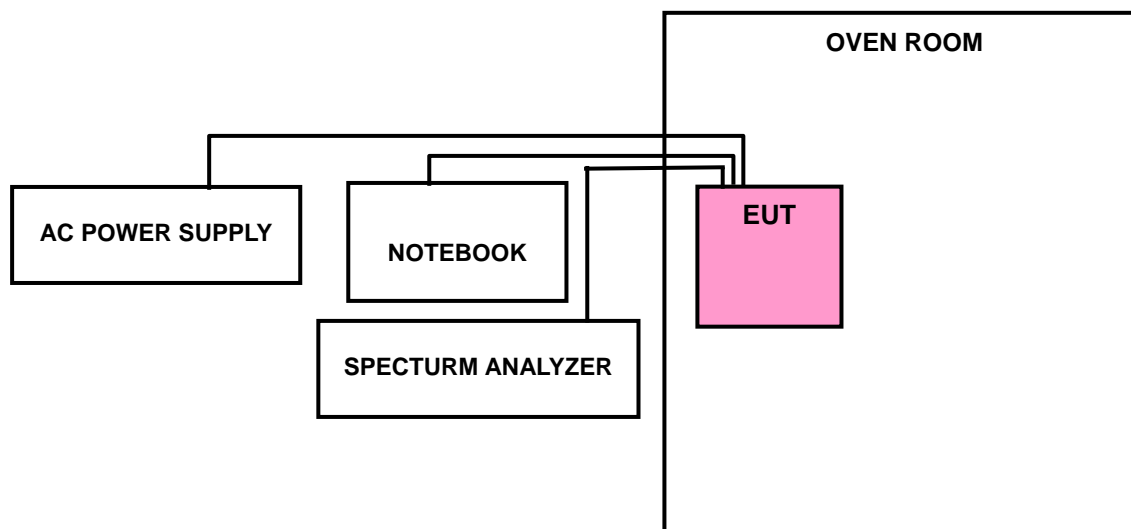

4.2.5 EUT OPERATING CONDITIONS

Same as 4.1.5



A D T

4.2.6 TEST RESULTS

MODE	Middle channel	ENVIRONMENTAL CONDITIONS	23degoC, 62%RH 991hPa
CHANNEL BANDWIDTH	5MHz	TESTED BY	Mark Liao

AFC FREQUENCY ERROR VS. VOLTAGE			
VOLTAGE (Volts)	TEMP. (°C)	FREQUENCY (MHz)	FREQUENCY ERROR (ppm)
93.5	20	2600.001500	0.577
110.0	20	2600.000212	0.082
126.5	20	2600.001569	0.603

AFC FREQUENCY ERROR VS. TEMP.			
VOLTAGE (Volts)	TEMP. (°C)	FREQUENCY (MHz)	FREQUENCY ERROR (ppm)
110.0	50	2600.000725	0.279
110.0	40	2600.000210	0.081
110.0	30	2600.000225	0.087
110.0	20	2600.000212	0.082
110.0	10	2600.000609	0.234
110.0	0	2600.000573	0.220
110.0	-10	2600.000550	0.212
110.0	-20	2600.000565	0.217
110.0	-30	2600.000590	0.227



A D T

MODE	Middle channel	ENVIRONMENTAL CONDITIONS	23degoC, 62%RH 991hPa
CHANNEL BANDWIDTH	10MHz	TESTED BY	Mark Liao

AFC FREQUENCY ERROR VS. VOLTAGE			
VOLTAGE (Volts)	TEMP. (°C)	FREQUENCY (MHz)	FREQUENCY ERROR (ppm)
93.5	20	2600.001576	0.606
110.0	20	2600.000731	0.281
126.5	20	2600.001246	0.479

AFC FREQUENCY ERROR VS. TEMP.			
VOLTAGE (Volts)	TEMP. (°C)	FREQUENCY (MHz)	FREQUENCY ERROR (ppm)
110.0	50	2600.000472	0.182
110.0	40	2600.000567	0.218
110.0	30	2600.000892	0.343
110.0	20	2600.000731	0.281
110.0	10	2600.000663	0.255
110.0	0	2600.000479	0.184
110.0	-10	2600.001017	0.391
110.0	-20	2600.000346	0.133
110.0	-30	2600.000376	0.145

4.3 EMISSION BANDWIDTH MEASUREMENT

4.3.1 LIMITS OF EMISSION BANDWIDTH MEASUREMENT

According to FCC 27.53(m)(6) specified that emission bandwidth is defined as the width of the signal between two points, one below the carrier center frequency and one above the carrier center frequency, outside of which all emissions are attenuated at least 26dB below the transmitter power.

4.3.2 TEST INSTRUMENTS

DESCRIPTION & MANUFACTURER	MODEL NO.	SERIAL NO.	DATE OF CALIBRATION	DUE DATE OF CALIBRATION
Spectrum Analyzer Agilent	E4446A	MY44360124	Feb. 05, 2010	Feb. 04, 2011
RF cable	SUCOFLEX 104	257029	Sep. 12, 2009	Sep. 11, 2010
WIT Standard Temperature & Humidity Chamber	MHU-225AU	920409	May 06, 2010	May 05, 2011

NOTE: The calibration interval of the above test instruments is 12 months. And the calibrations are traceable to NML/ROC and NIST/USA.

4.3.3 TEST PROCEDURE

The transmitter output was connected to the spectrum analyzer through an attenuator. The bandwidth of the fundamental frequency was measured by spectrum analyzer with RBW = 51kHz, VBW = 160kHz. The 26dB bandwidth is defined as the total spectrum the power of which is higher than peak power minus 26dB.

4.3.4 TEST SETUP

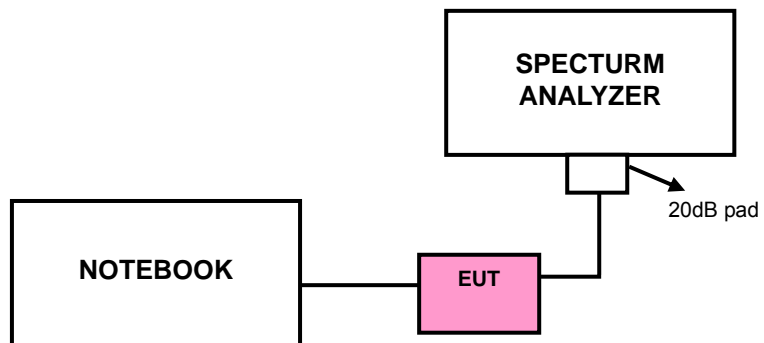

4.3.5 EUT OPERATING CONDITIONS

Same as 4.1.5



A D T

4.3.6 TEST RESULTS

CHANNEL BANDWIDTH: 5MHz

CHANNEL	-26dBc BANDWIDTH (MHz)
Low	4.842
Middle	4.839
High	4.841

LOW CHANNEL

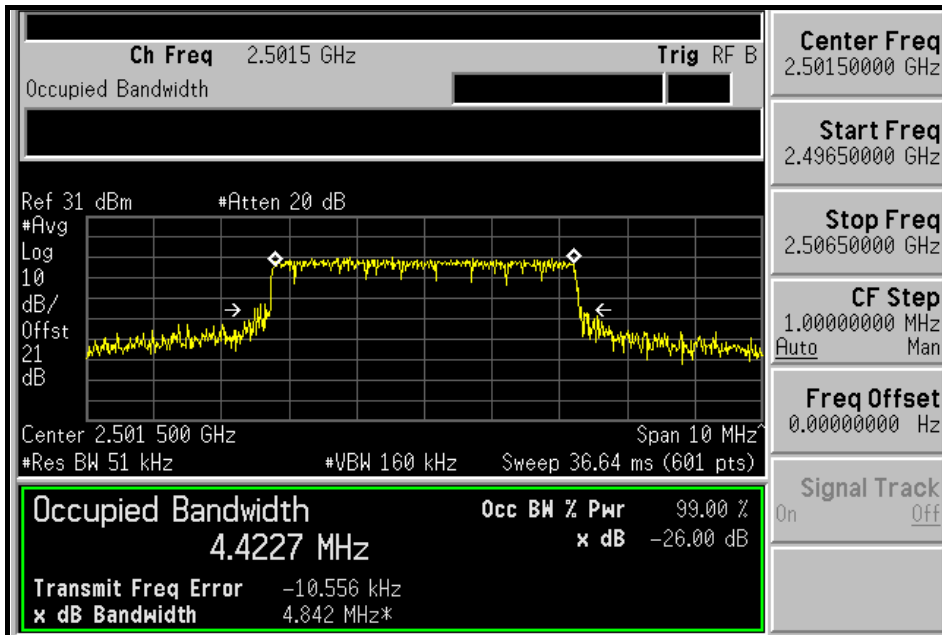



A D T

CHANNEL BANDWIDTH: 10MHz

CHANNEL	-26dBc BANDWIDTH (MHz)
Low	9.679
Middle	9.676
High	9.678

LOW CHANNEL

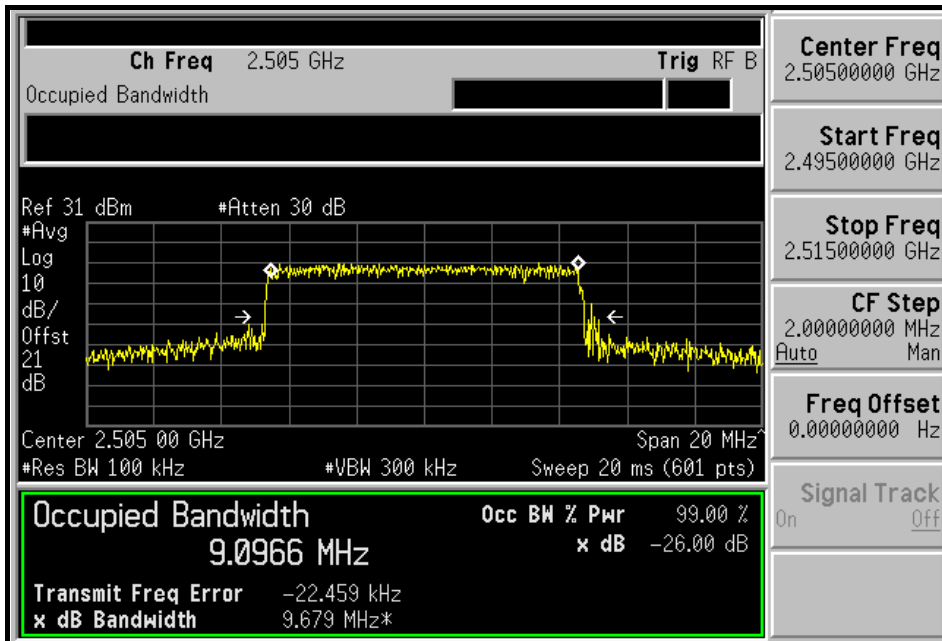



4.4 CHANNEL EDGE MEASUREMENT

4.4.1 LIMITS OF CHANNEL EDGE MEASUREMENT

According to FCC 27.53(m)(4) specified that power of any emission outside of the channel edge must be attenuated below the transmitting power (P) by a factor shall be not less than $43 + 10 \log (P)$ dB at the channel edge, the limit of emission equal to -13dBm . And $55 + 10 \log (P)$ dB at 5.5 MHz from the channel edges, the limit of emission equal to -25dBm . In the 1MHz bands immediately outside and adjacent to the frequency block a resolution bandwidth of at least one percent of the emission bandwidth of the fundamental emission of the transmitter may be employed.

4.4.2 TEST INSTRUMENTS

DESCRIPTION & MANUFACTURER	MODEL NO.	SERIAL NO.	DATE OF CALIBRATION	DUE DATE OF CALIBRATION
Spectrum Analyzer Agilent	E4446A	MY44360124	Feb. 05, 2010	Feb. 04, 2011
RF cable	SUCOFLEX 104	257029	Sep. 12, 2009	Sep. 11, 2010
WIT Standard Temperature & Humidity Chamber	MHU-225AU	920409	May 06, 2010	May 05, 2011

- NOTE:** 1. The calibration interval of the above test instruments is 12 months. And the calibrations are traceable to NML/ROC and NIST/USA.
2. “*” = These equipments are used for the final measurement.

4.4.3 TEST SETUP

Same as Item 4.3.4



A D T

4.4.4 TEST PROCEDURES

- a. The EUT was set up for the rated peak power. The power was measured with Spectrum Analyzer. All measurements were done at 3 channels: low, middle and high operational frequency range.
- b. The center frequency of spectrum is the band edge frequency and span is 20MHz (Channel Bandwidth: 5MHz) / 30MHz (Channel Bandwidth: 10MHz). RBW of the spectrum is 51kHz (Channel Bandwidth: 5MHz) / 100kHz (Channel Bandwidth: 10MHz).
- c. Record the max trace plot into the test report.

4.4.5 EUT OPERATING CONDITION

Same as 4.1.5



A D T

4.4.6 TEST RESULTS

CHANNEL BANDWIDTH: 5MHz

LOW CHANNEL

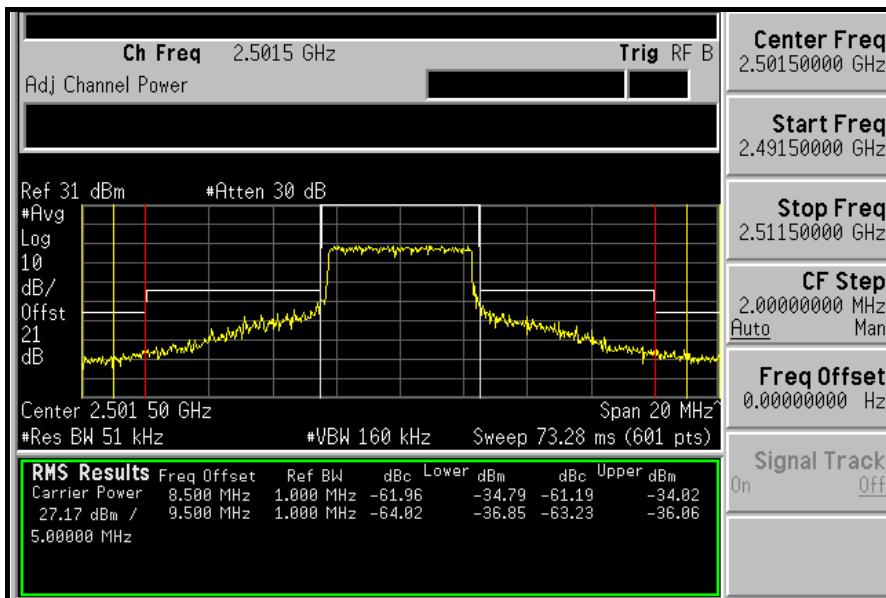
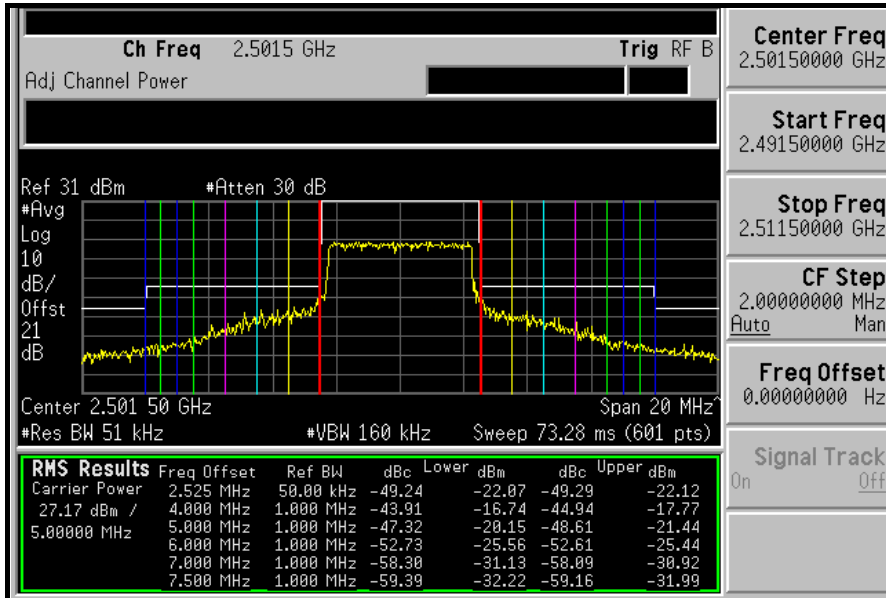



A D T

MIDDLE CHANNEL

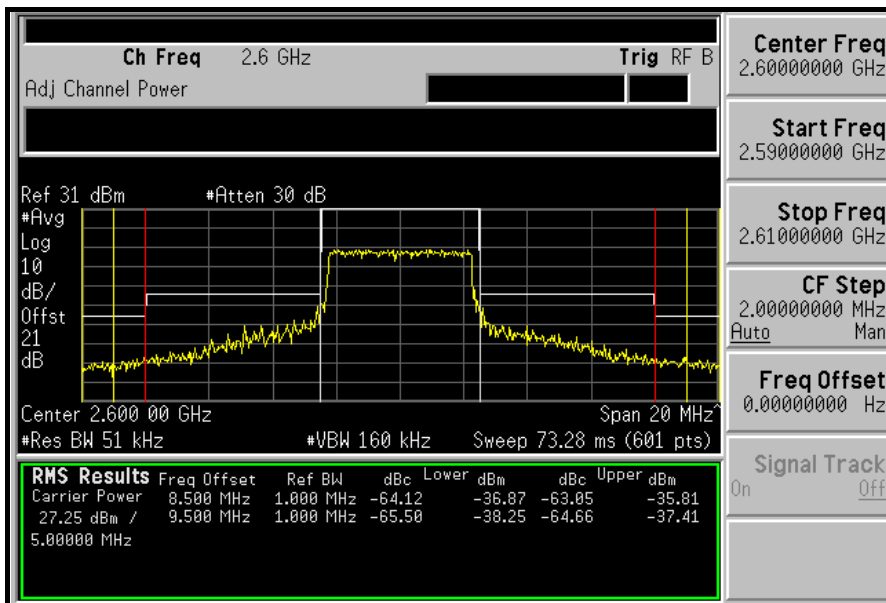
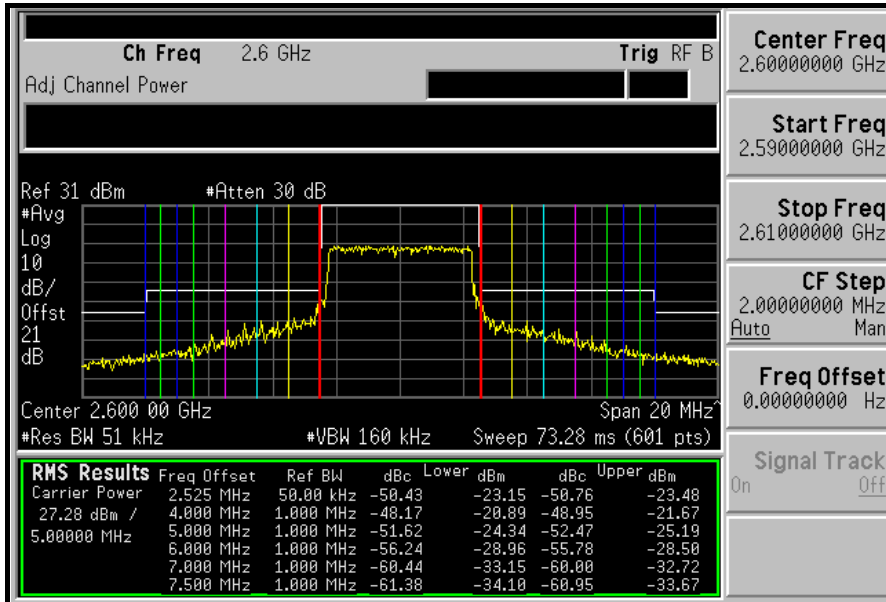



A D T

HIGH CHANNEL

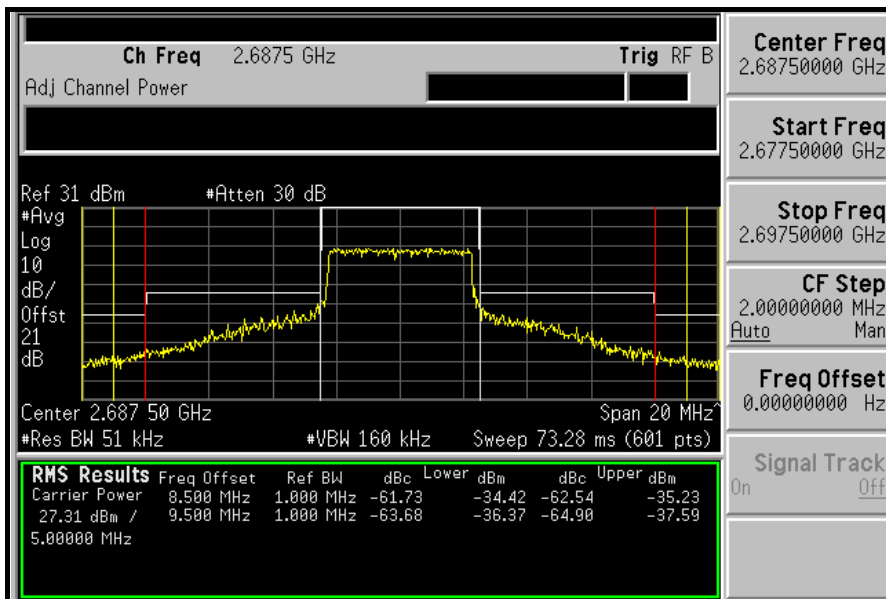
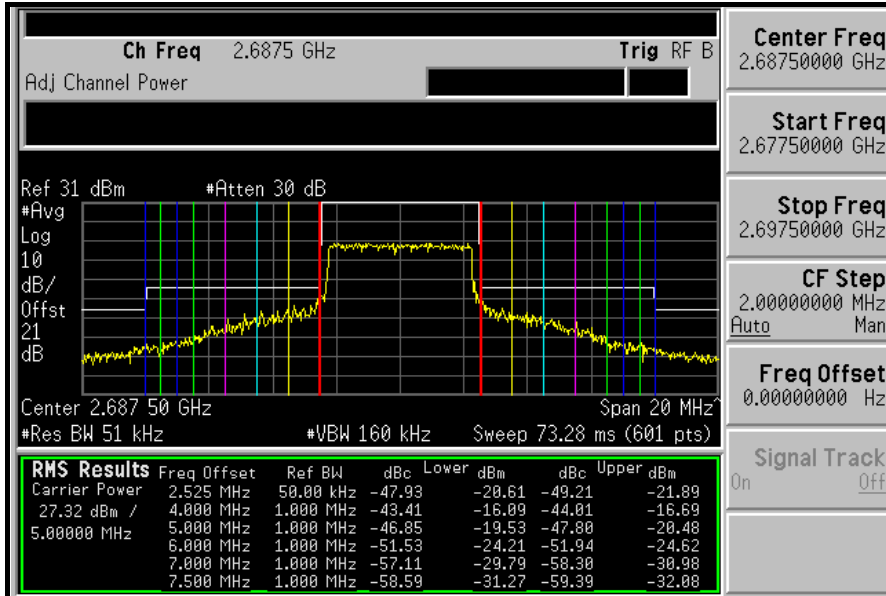



A D T

CHANNEL BANDWIDTH: 10MHz

LOW CHANNEL

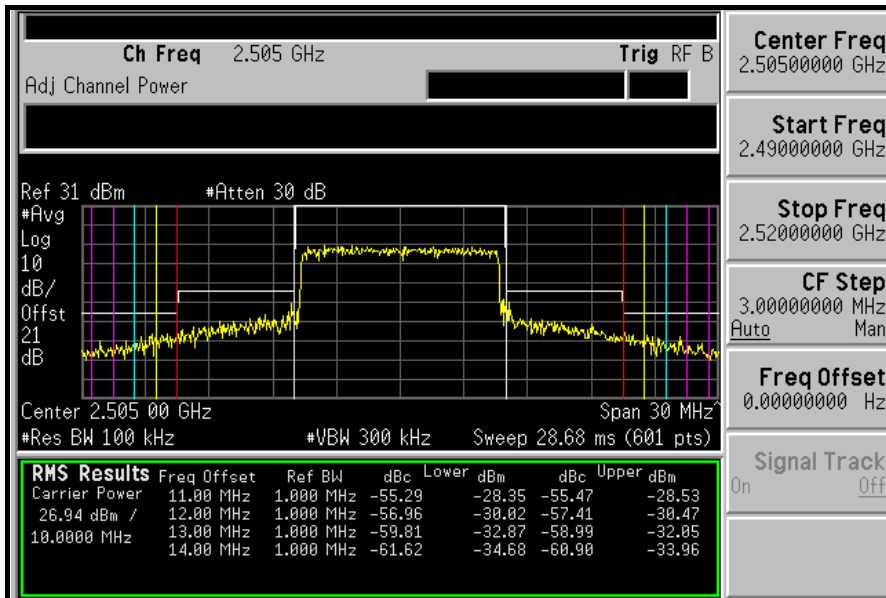
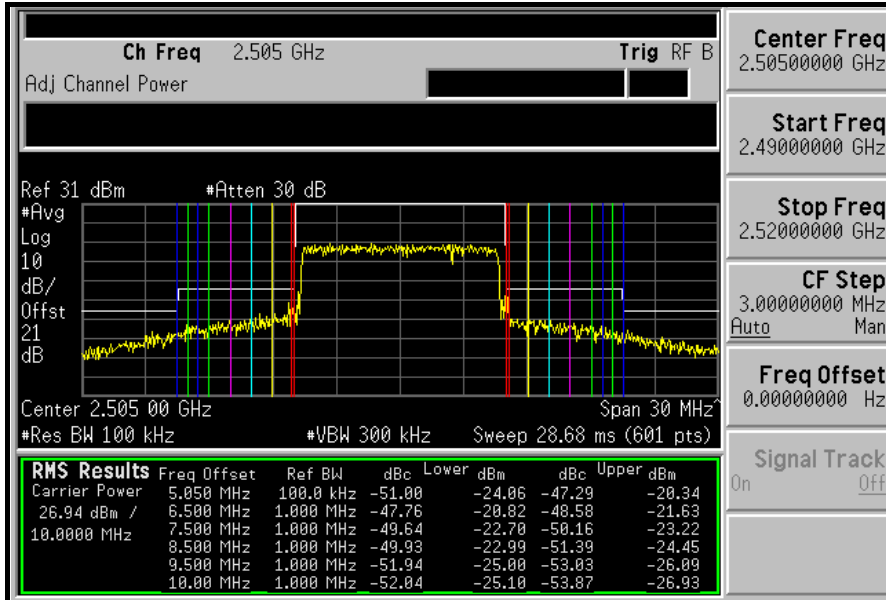



A D T

MIDDLE CHANNEL

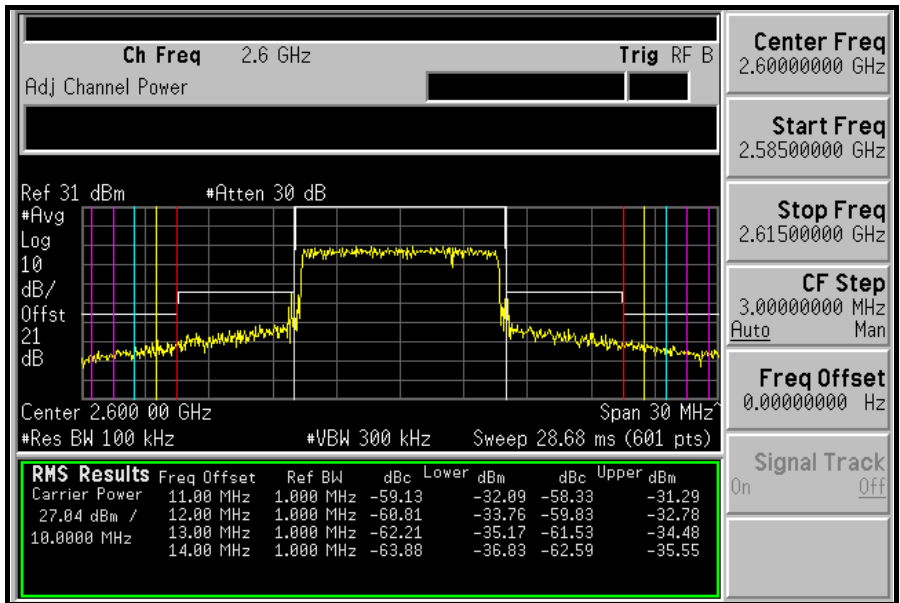
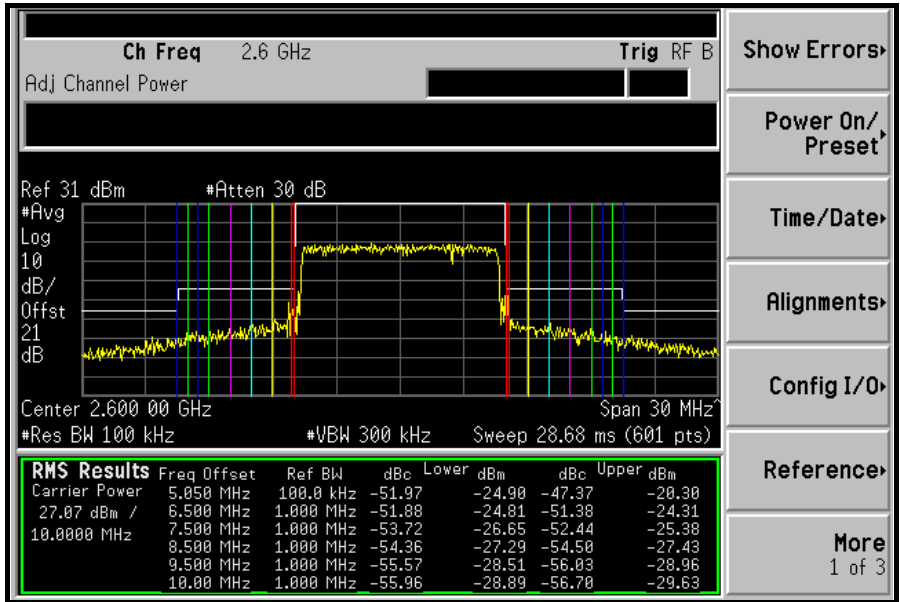



A D T

HIGH CHANNEL

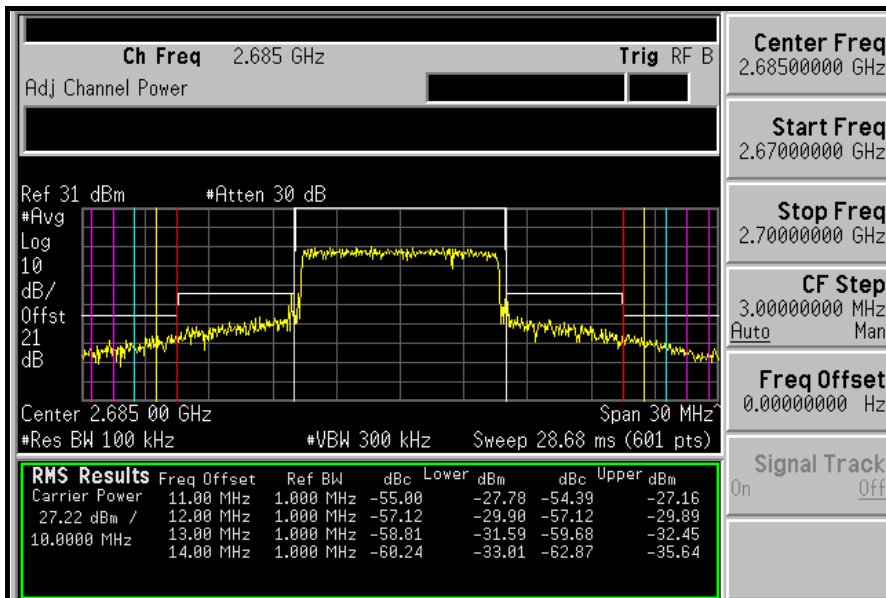
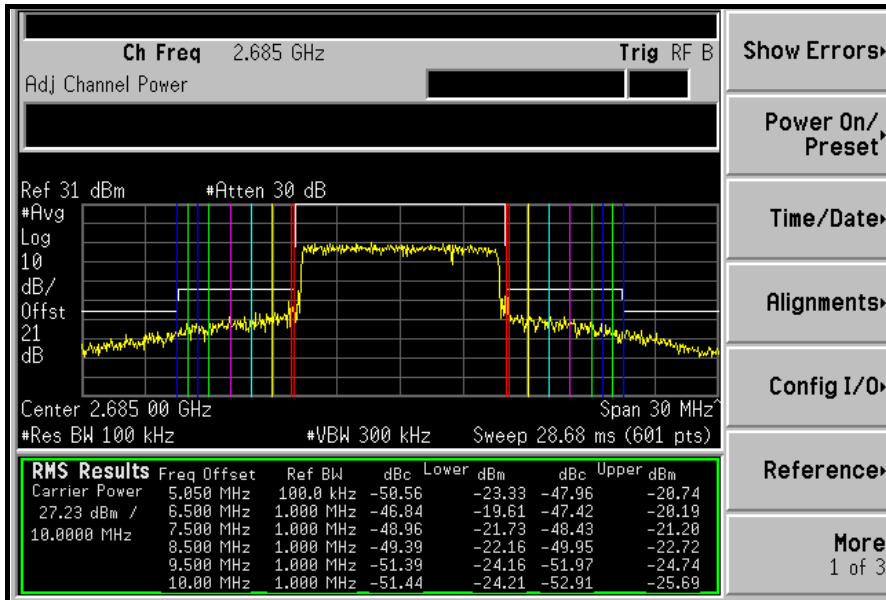



A D T

4.5 CONDUCTED SPURIOUS EMISSIONS

4.5.1 LIMITS OF CONDUCTED SPURIOUS EMISSIONS MEASUREMENT

In the FCC 27.53(m)(4), On any frequency outside a licensee's frequency block, the power of any emission shall be attenuated below the transmitter power (P) by at least $55 + 10 \log (P)$ dB. The limit of emission equal to -25 dBm.

4.5.2 TEST INSTRUMENTS

DESCRIPTION & MANUFACTURER	MODEL NO.	SERIAL NO.	DATE OF CALIBRATION	DUE DATE OF CALIBRATION
Spectrum Analyzer Agilent	E4446A	MY44360128	Feb. 23, 2010	Feb. 22, 2011
Wainwright Instruments High Pass Filter	WHK3.1/18G-10 SS	ZZ-010096	May. 25, 2010	Mar. 24, 2011
JFW 20dB attenuation	50HF-020-SMA	NA	NA	NA
RF cable	SUCOFLEX 104	257029	Sep. 12, 2009	Sep. 11, 2010

NOTE: 1. The calibration interval of the above test instruments is 12 months. And the calibrations are traceable to NML/ROC and NIST/USA.



A D T

4.5.3 TEST PROCEDURE

- a. All measurements were done at 3 channels: low, middle and high operational frequency range.
- b. When the spectrum scanned from 30MHz to 27GHz, it shall be connected to the 20dB pad attenuated the carried frequency. The spectrum set $RB = 1\text{MHz}$, $VB = 3\text{MHz}$.

4.5.4 TEST SETUP

Same as 4.3.4

4.5.5 EUT OPERATING CONDITIONS

Same as 4.1.5



A D T

4.5.6 TEST RESULTS

CHANNEL BANDWIDTH: 5MHz

LOW CHANNEL: 30MHz ~ 1GHz:

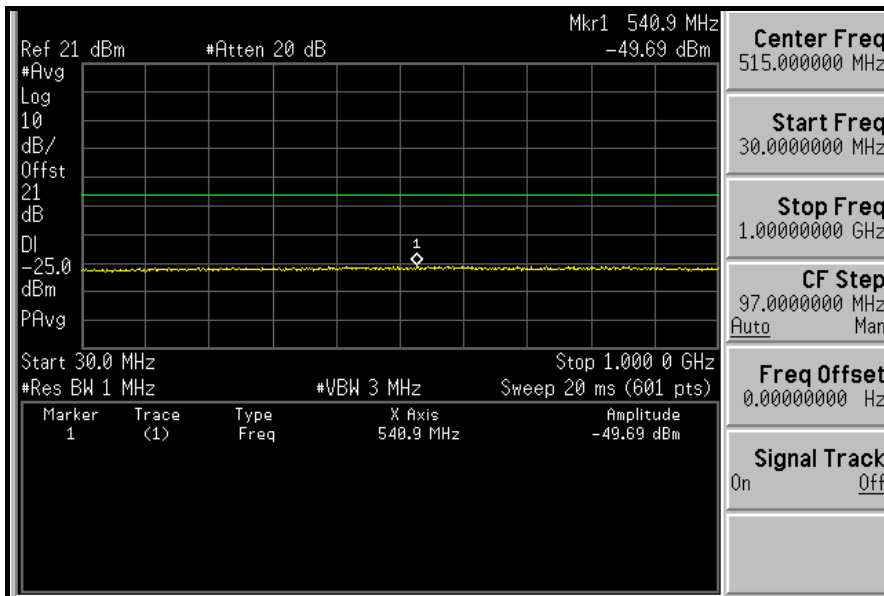

1GHz ~ 3GHz:

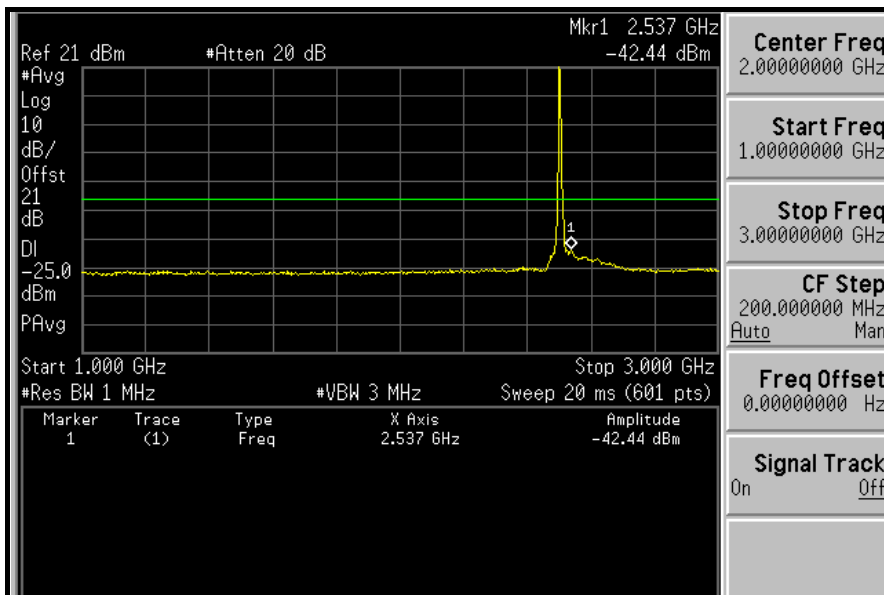



A D T

3GHz ~ 10GHz:

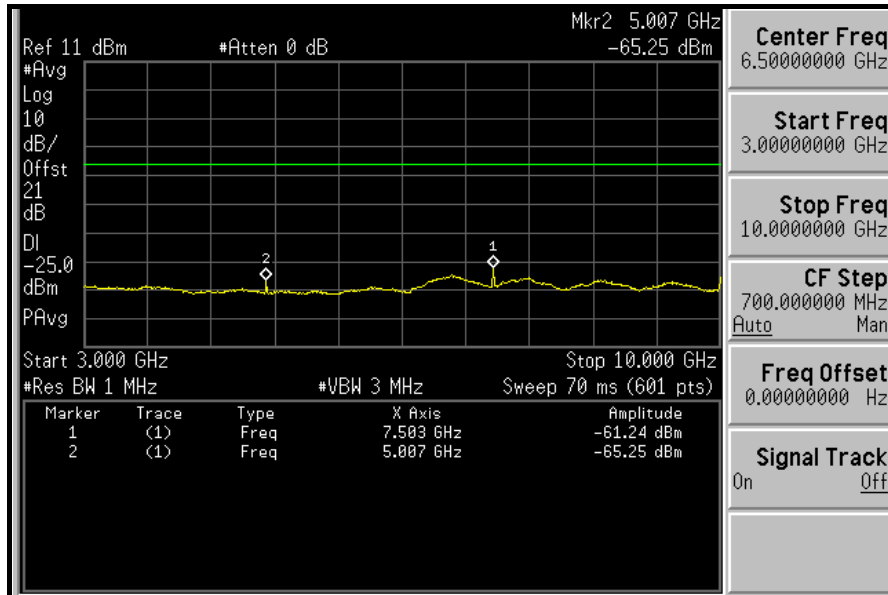

10GHz ~ 27GHz:

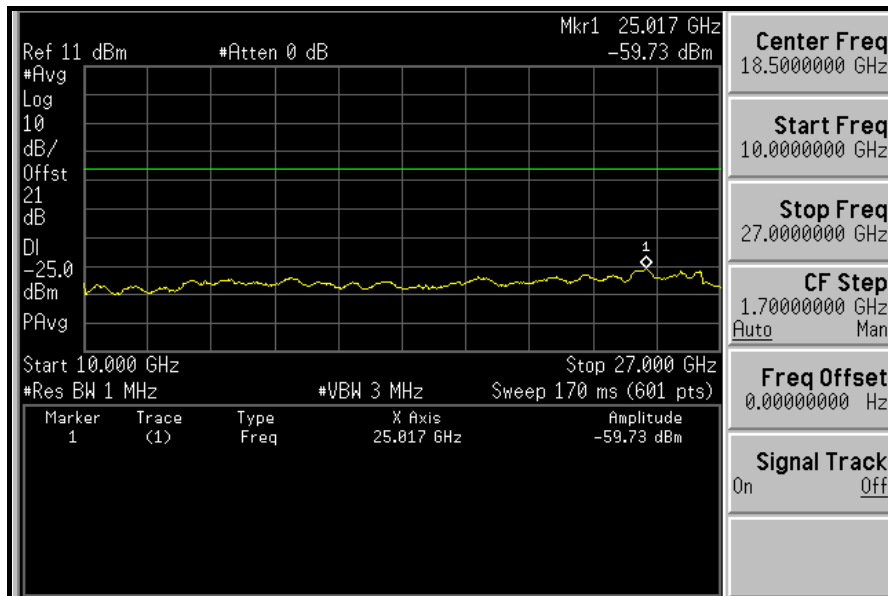



A D T

MIDDLE CHANNEL: 30MHz ~ 1GHz:

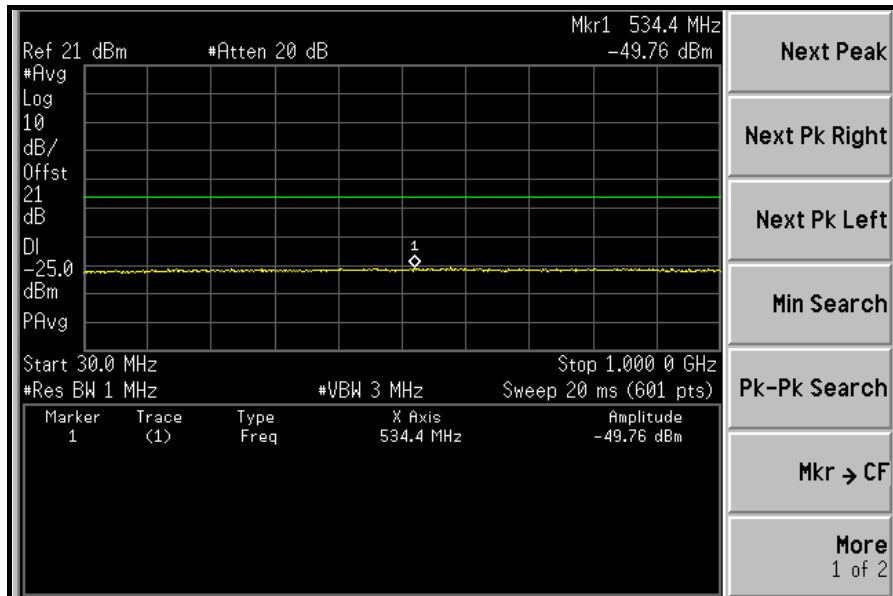

1GHz ~ 3GHz:

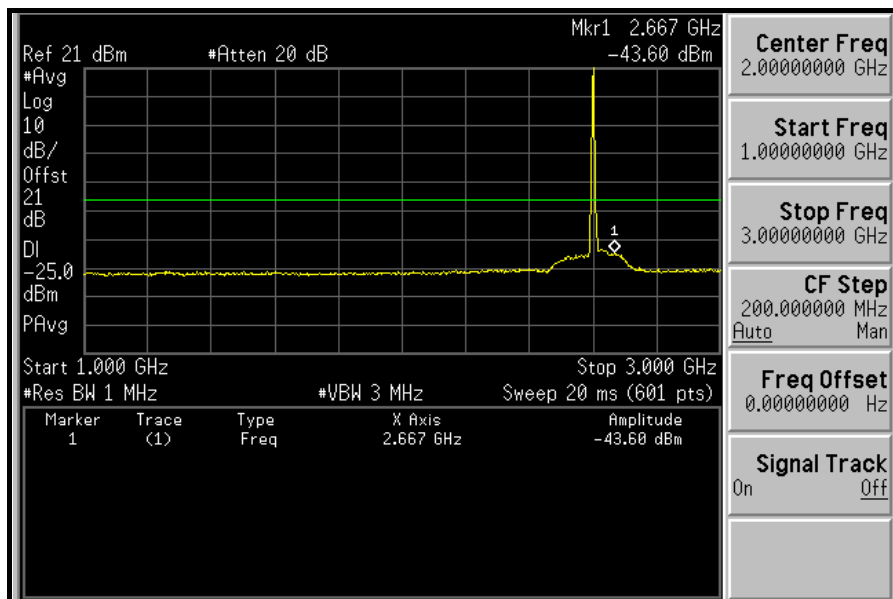



A D T

3GHz ~ 10GHz:

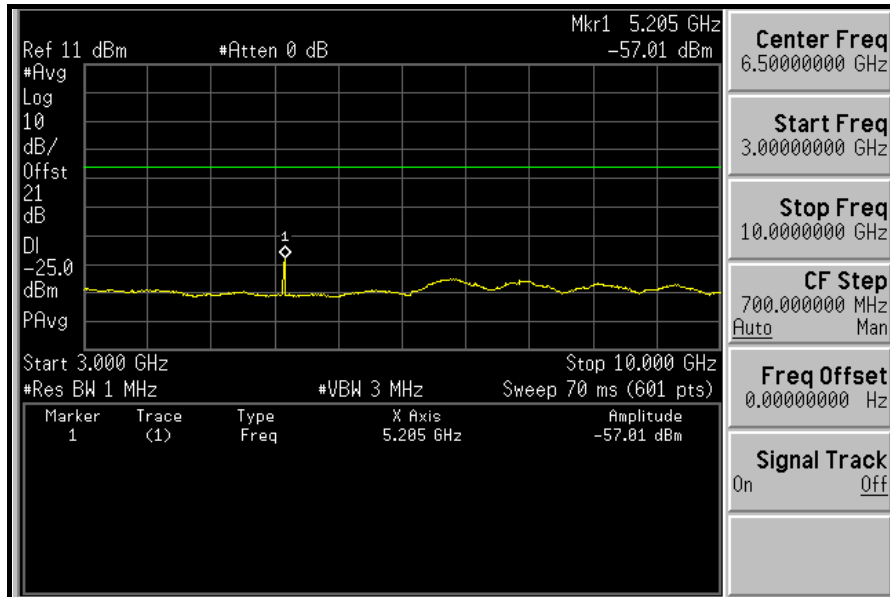

10GHz ~ 27GHz:

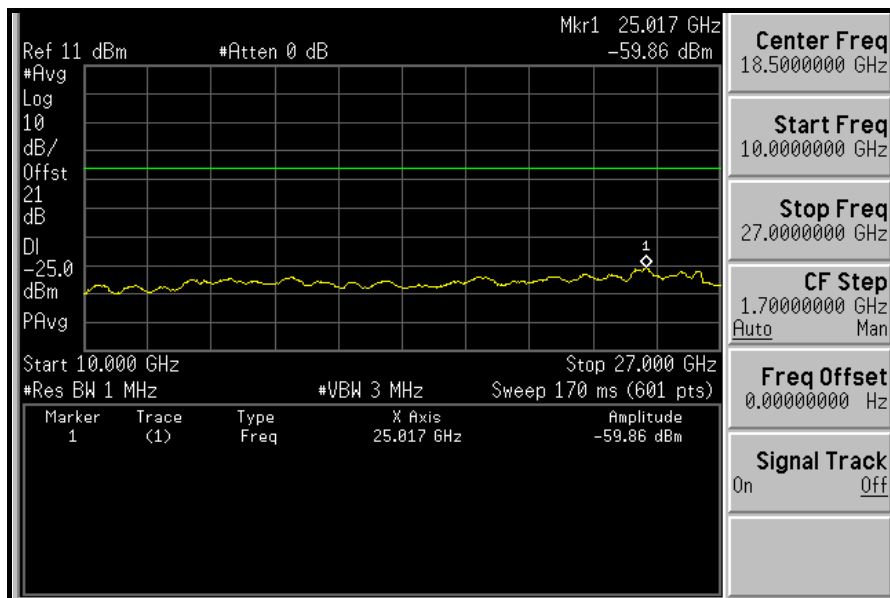



A D T

HIGH CHANNEL: 30MHz ~ 1GHz:

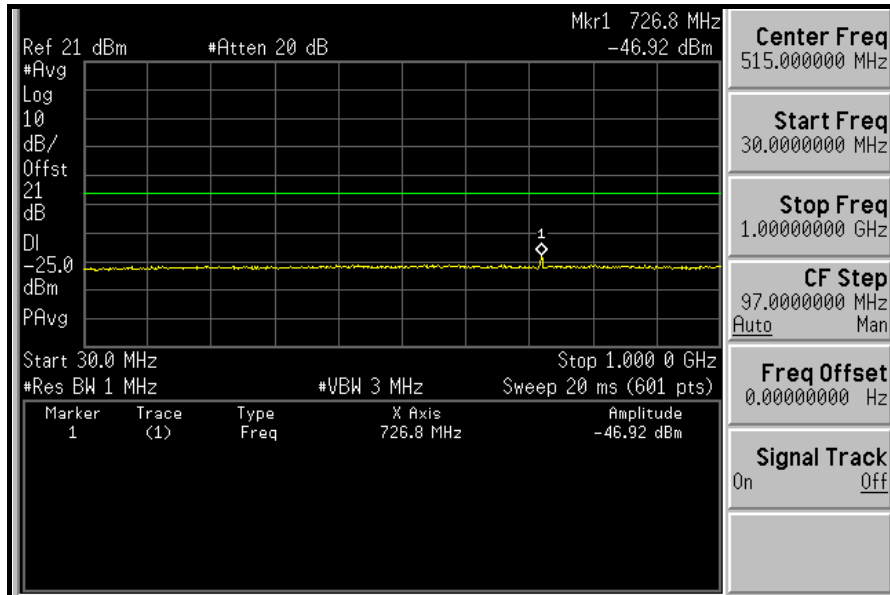

1GHz ~ 3GHz:

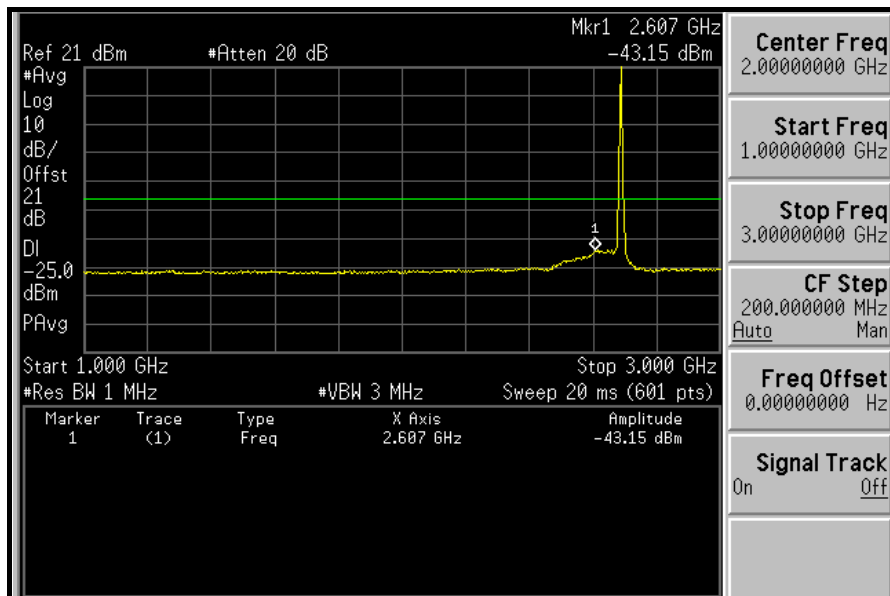



A D T

3GHz ~ 10GHz:

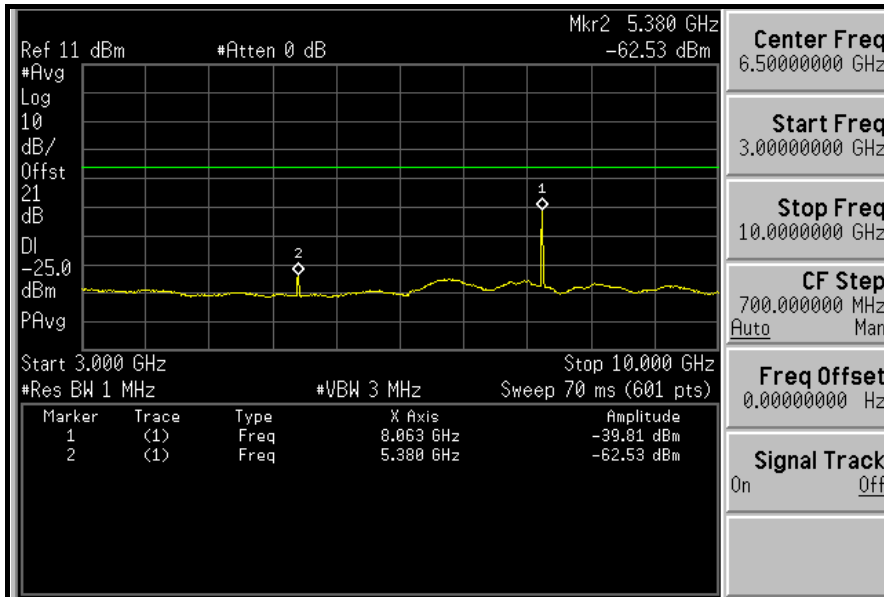

10GHz ~ 27GHz:

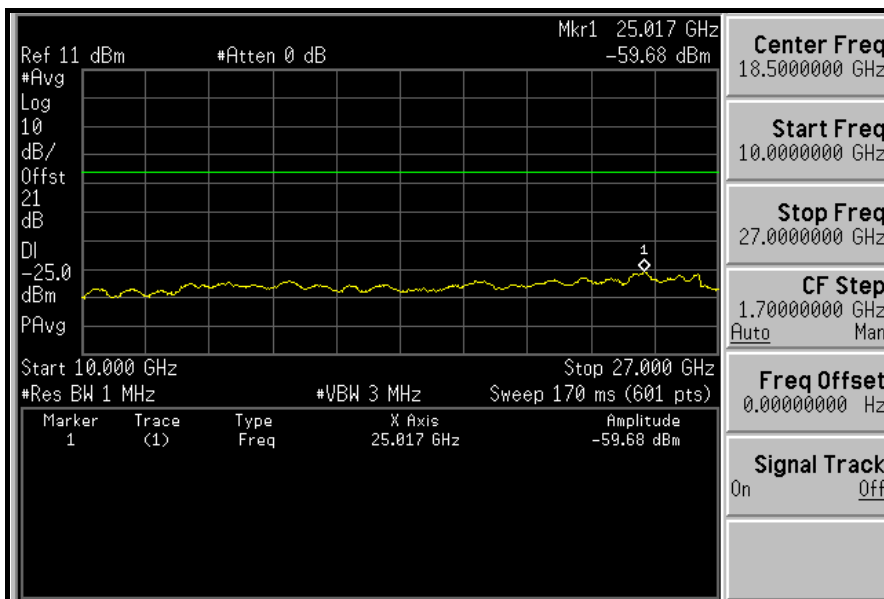



A D T

CHANNEL BANDWIDTH: 10MHz

LOW CHANNEL: 30MHz ~ 1GHz:

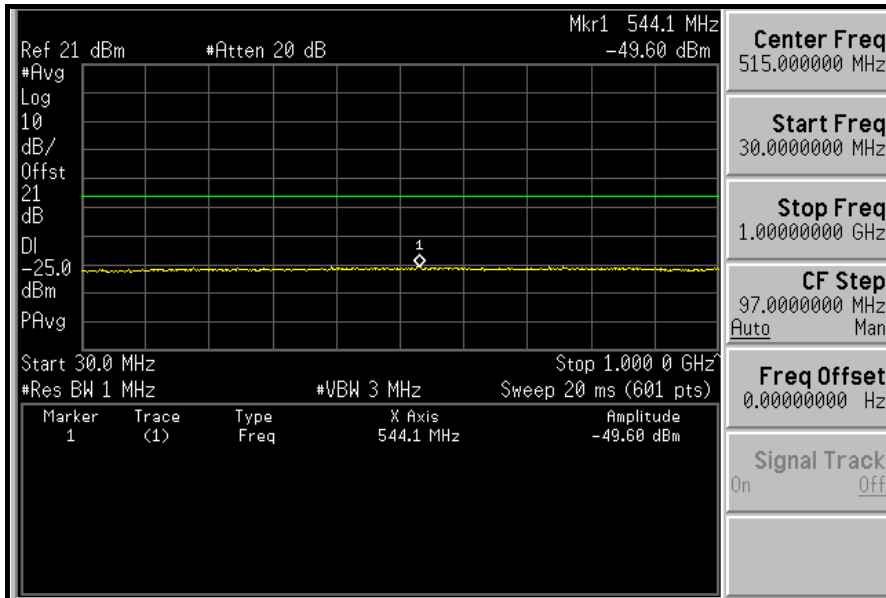

1GHz ~ 3GHz:

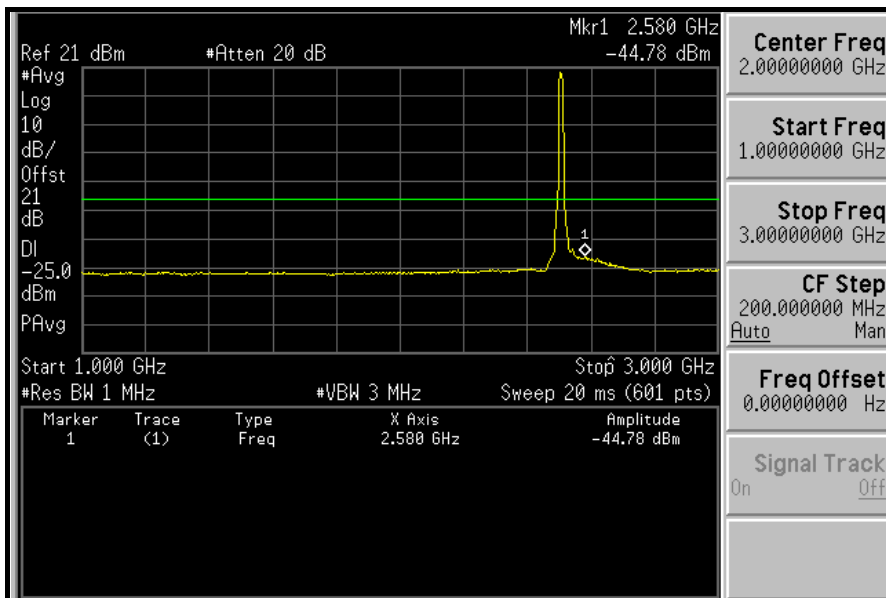



A D T

3GHz ~ 10GHz:

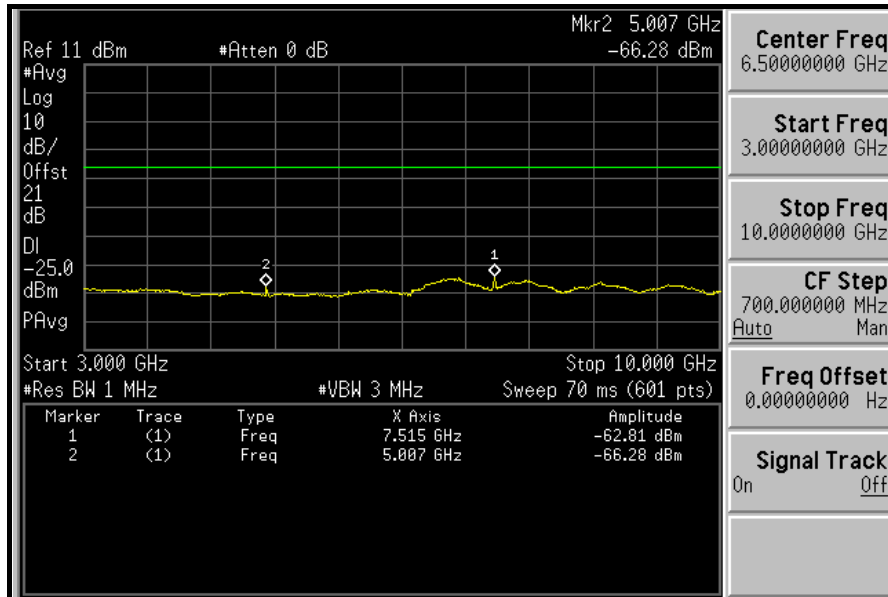

10GHz ~ 27GHz:

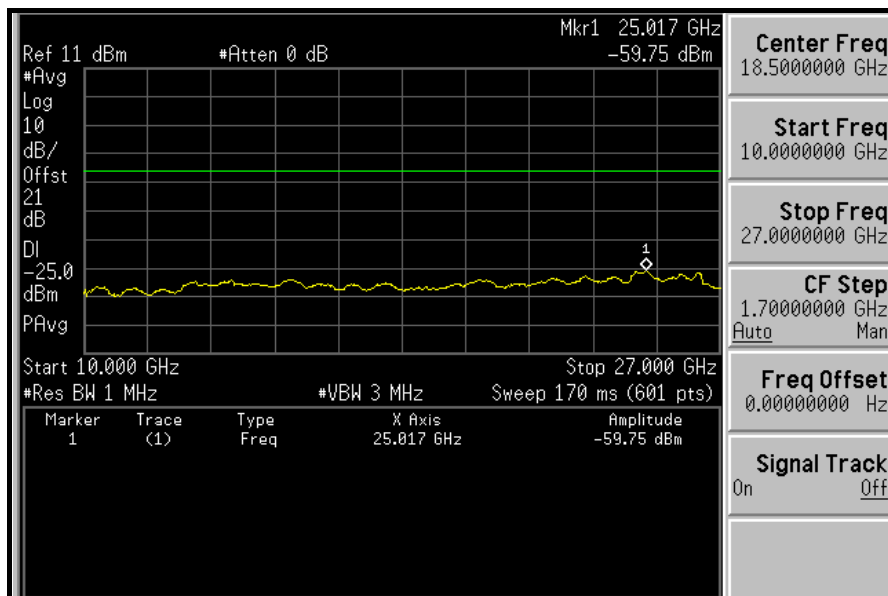



A D T

MIDDLE CHANNEL: 30MHz ~ 1GHz:

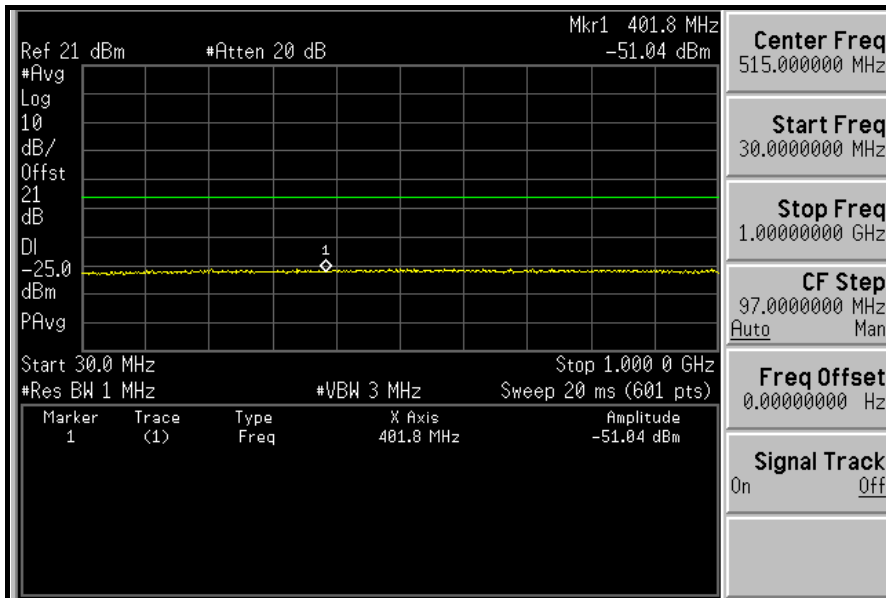

1GHz ~ 3GHz:

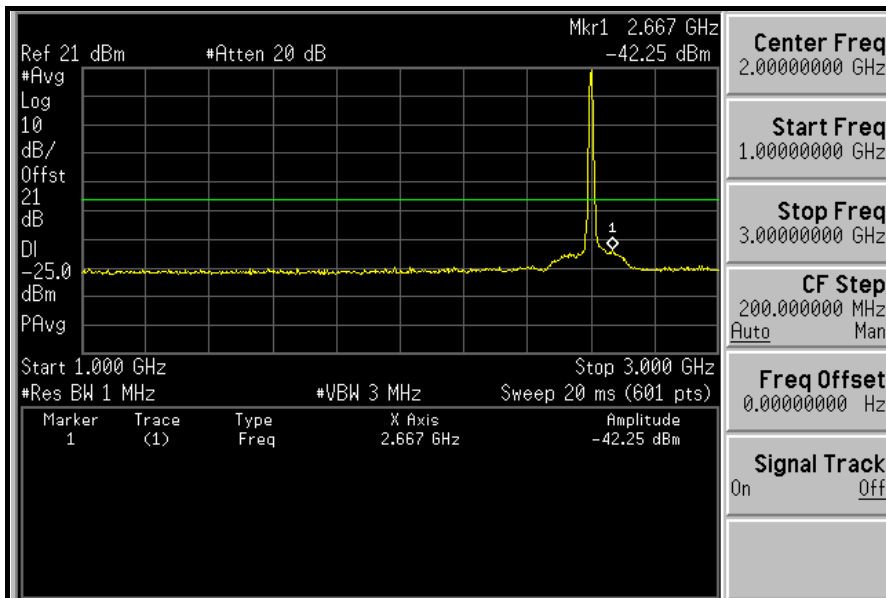



A D T

3GHz ~ 10GHz:

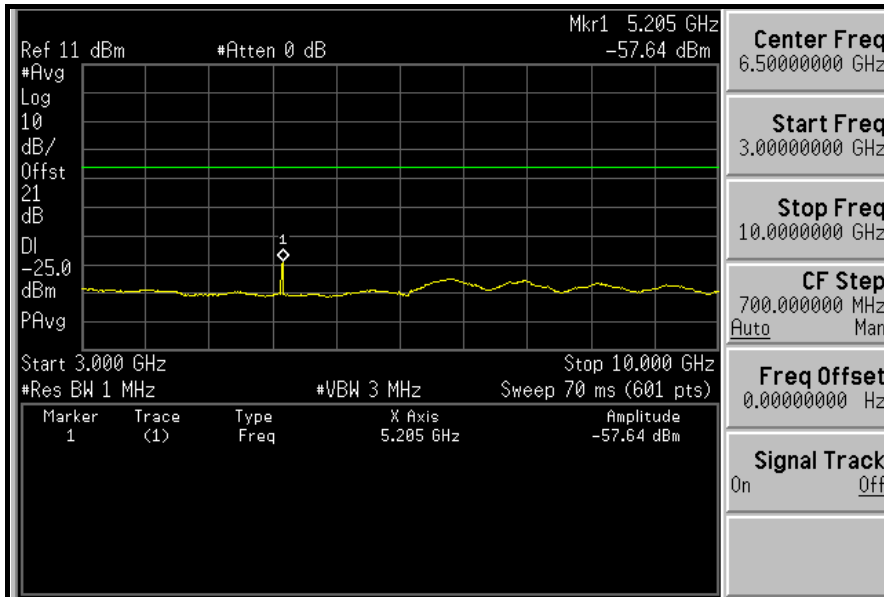

10GHz ~ 27GHz:

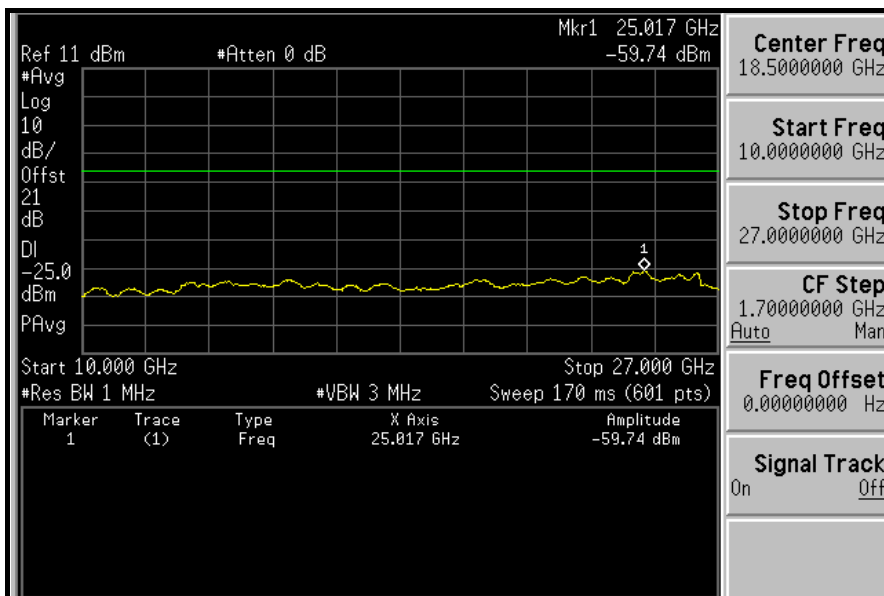



A D T

HIGH CHANNEL: 30MHz ~ 1GHz:

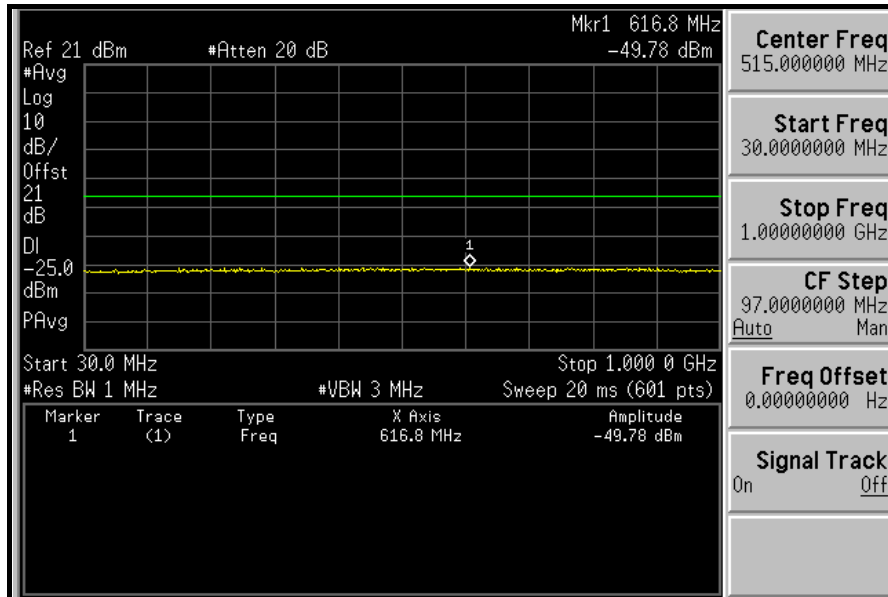

1GHz ~ 3GHz:

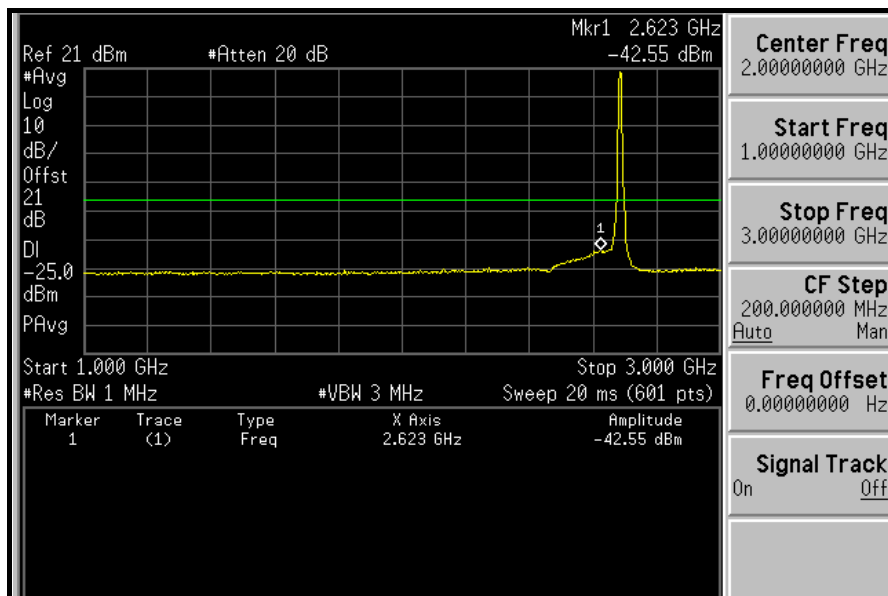



A D T

3GHz ~ 10GHz:

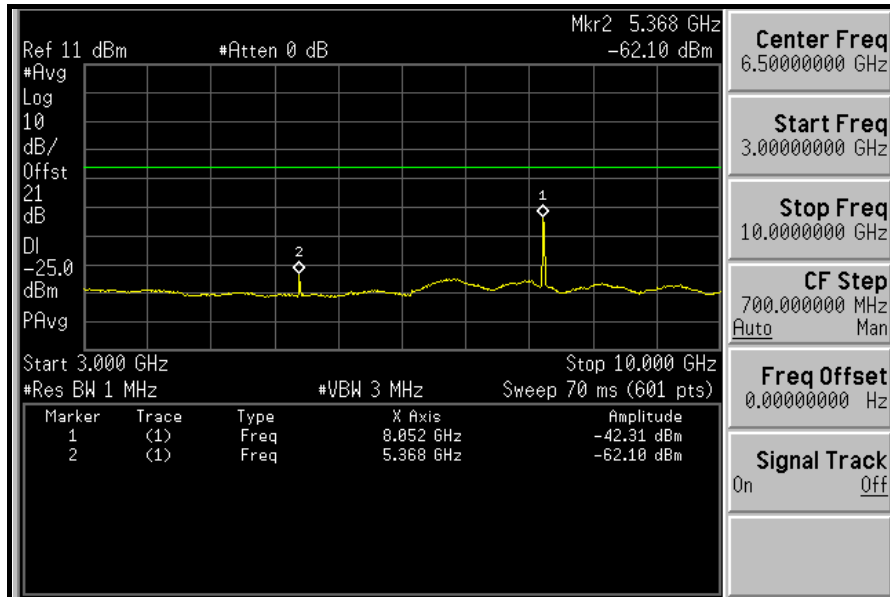

10GHz ~ 27GHz:

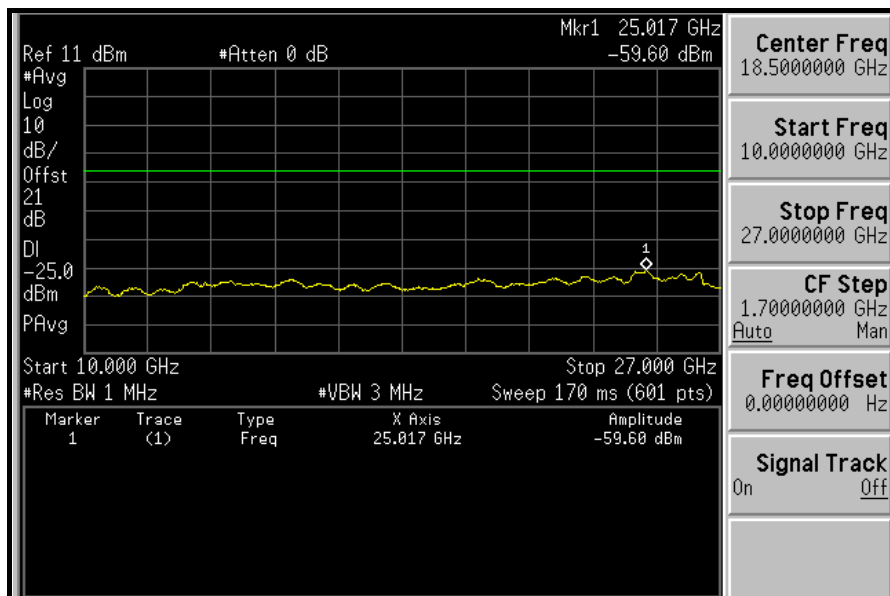



A D T

4.6 RADIATED EMISSION MEASUREMENT (BELOW 1GHz)

4.6.1 LIMITS OF RADIATED EMISSION MEASUREMENT

In the FCC 27.53(m) (4), On any frequency outside a licensee's frequency block the power of any emission shall be attenuated below the transmitter power (P) by at least $55 + 10 \log (P)$ dB. The limit of emission equal to -25 dBm.



4.6.2 TEST INSTRUMENTS

DESCRIPTION & MANUFACTURER	MODEL NO.	SERIAL NO.	DATE OF CALIBRATION	DUE DATE OF CALIBRATION
Test Receiver ROHDE & SCHWARZ	ESI7	838496/016	Dec. 29, 2009	Dec. 28, 2010
Spectrum Analyzer ROHDE & SCHWARZ	FSP40	100039	Jan. 11, 2010	Jan. 10, 2011
BILOG Antenna SCHWARZBECK	VULB9168	9168-155	Apr. 28, 2010	Apr. 27, 2011
HORN Antenna SCHWARZBECK	BBHA 9120D	9120D-408	Jan. 05, 2010	Jan. 04, 2011
HORN Antenna SCHWARZBECK	BBHA 9170	BBHA9170242	Dec. 25, 2009	Dec. 24, 2010
Preamplifier Agilent	8449B	3008A01961	Nov. 04, 2009	Nov. 03, 2010
Preamplifier Agilent	8447D	2944A10738	Nov. 04, 2009	Nov. 03, 2010
RF signal cable HUBER+SUHNNER	SUCOFLEX 104	238141/4	May 14, 2010	May 13, 2011
RF signal cable HUBER+SUHNNER	SUCOFLEX 104	12738/6	May 14, 2010	May 13, 2011
Software ADT.	ADT_Radiated_ V7.6.15.9.2	NA	NA	NA
Antenna Tower inn-co GmbH	MA 4000	010303	NA	NA
Antenna Tower Controller inn-co GmbH	CO2000	019303	NA	NA
Turn Table ADT.	TT100.	TT93021704	NA	NA
Turn Table Controller ADT.	SC100.	SC93021704	NA	NA

- NOTE:**
1. The calibration interval of the above test instruments is 12 months and the calibrations are traceable to NML/ROC and NIST/USA.
 2. The test was performed in HwaYa Chamber 4.
 3. The horn antenna and HP preamplifier (model: 8449B) are used only for the measurement of emission frequency above 1GHz if tested.
 4. The FCC Site Registration No. is 988962.
 5. The IC Site Registration No. is IC7450F-4.



4.6.3 TEST PROCEDURES

- a. The power was measured with R&S Spectrum Analyzer. All measurements were done at 3 channels (low, middle and high channel of operational frequency range.)
- b. Substitution method is used for E.I.R.P measurement. In the semi-anechoic chamber, EUT placed on the 0.8m height of Turn Table, rotated the table around 360 degrees to search the maximum radiation power and receiver antenna shall be rotated vertical and horizontal polarization and moved height from 1m to 4m to find the maximum polar radiated power. The “Read Value” is the spectrum reading the maximum power value.
- c. The substitution antenna is substituted for EUT at the same position and signals generator export the CW signal to the substitution antenna via a TX cable. Rotated the Turn Table and moved receiving antenna to find the maximum radiation power. Adjust output power level of S.G to get a Value of spectrum reading equal to “Read Value “ of step b. Record the power level of S.G
- d. $EIRP = \text{Output power level of S.G} - \text{TX cable loss} + \text{Antenna gain of substitution antenna.}$

NOTE: The resolution bandwidth and video bandwidth of test receiver/spectrum analyzer is 1MHz/3MHz

4.6.4 DEVIATION FROM TEST STANDARD

No deviation

4.6.5 TEST SETUP

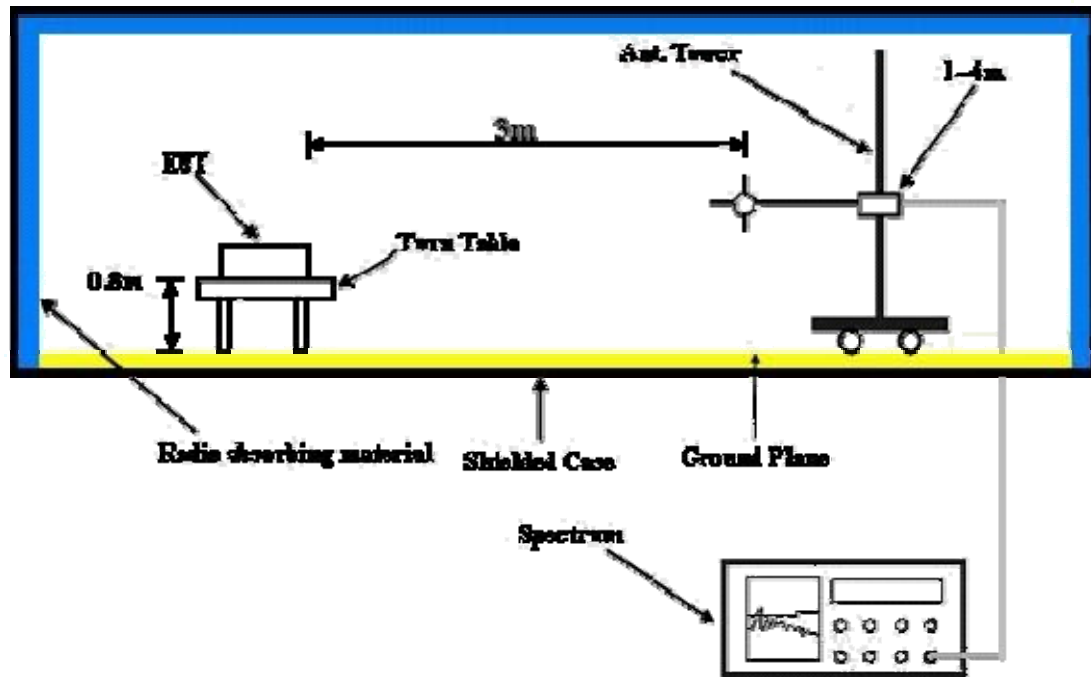

For the actual test configuration, please refer to the related item – Photographs of the Test Configuration.

4.6.6 EUT OPERATING CONDITIONS

Same as 4.1.5



4.6.7 TEST RESULTS

MODE	Mid. channel	FREQUENCY RANGE	Below 1000MHz
INPUT POWER	120Vac, 60Hz	ENVIRONMENTAL CONDITIONS	23degoC, 62%RH 991hPa
CHANNEL BANDWIDTH	5MHz	TEST MODE	A
TESTED BY	Mark Liao		

ANTENNA POLARITY & TEST DISTANCE: HORIZONTAL AT 3m						
NO.	FREQ. (MHz)	EMISSION LEVEL (dBuV)	LIMIT (dBm)	S.G POWER VALUE (dBm)	CORRECTION FACTOR (dB)	POWER VALUE (dBm)
1	61.1	52.2	-25.0	-34.7	-7.7	-42.4
2	158.3	56.6	-25.0	-30.5	-7.7	-38.2
3	208.84	57.9	-25.0	-29.4	-7.7	-37.1
4	360.46	55.0	-25.0	-32.2	-7.8	-40.0
5	479.04	51.5	-25.0	-35.4	-7.8	-43.2
6	718.14	41.2	-25.0	-45.6	-7.9	-53.5
ANTENNA POLARITY & TEST DISTANCE: VERTICAL AT 3m						
NO.	FREQ. (MHz)	EMISSION LEVEL (dBuV/m)	LIMIT (dBm)	S.G POWER VALUE (dBm)	CORRECTION FACTOR (dB)	POWER VALUE (dBm)
1	82.48	55.9	-25.0	-30.8	-7.7	-38.5
2	218.56	54.8	-25.0	-32.4	-7.7	-40.1
3	296.31	52.5	-25.0	-34.5	-7.7	-42.2
4	360.46	50.0	-25.0	-36.7	-7.8	-44.5
5	479.04	51.2	-25.0	-35.3	-7.8	-43.1
6	677.31	44.3	-25.0	-42.4	-7.8	-50.2

NOTE 1: Power Value (dBum) = S.G Power Value (dBm) + Correction Factor (dB).

NOTE 2: Correction Factor = Antenna gain of substitution antenna- TX cable loss



A D T

MODE	Mid. channel	FREQUENCY RANGE	Below 1000MHz
INPUT POWER	120Vac, 60Hz	ENVIRONMENTAL CONDITIONS	23degoC, 62%RH 991hPa
CHANNEL BANDWIDTH	5MHz	TEST MODE	B
TESTED BY	Mark Liao		

ANTENNA POLARITY & TEST DISTANCE: HORIZONTAL AT 3m						
NO.	FREQ. (MHz)	EMISSION LEVEL (dBuV)	LIMIT (dBm)	S.G POWER VALUE (dBm)	CORRECTION FACTOR (dB)	POWER VALUE (dBm)
1	84.43	46.2	-25.0	-40.7	-7.7	-48.4
2	164.13	52.9	-25.0	-34.0	-7.7	-41.7
3	234.11	49.0	-25.0	-37.9	-7.7	-45.6
4	358.52	49.6	-25.0	-37.3	-7.8	-45.1
5	479.04	51.6	-25.0	-35.3	-7.8	-43.1
6	836.71	57.2	-25.0	-29.7	-7.9	-37.6
ANTENNA POLARITY & TEST DISTANCE: VERTICAL AT 3m						
NO.	FREQ. (MHz)	EMISSION LEVEL (dBuV/m)	LIMIT (dBm)	S.G POWER VALUE (dBm)	CORRECTION FACTOR (dB)	POWER VALUE (dBm)
1	41.66	48.7	-25.0	-37.9	-7.7	-45.6
2	337.13	48.1	-25.0	-38.9	-7.8	-46.7
3	480.98	47.8	-25.0	-38.9	-7.8	-46.7
4	564.57	52.8	-25.0	-34.0	-7.8	-41.8
5	825.05	50.9	-25.0	-36.0	-7.9	-43.9
6	896.97	45.5	-25.0	-41.3	-7.9	-49.2

NOTE 1: Power Value (dBum) = S.G Power Value (dBm) + Correction Factor (dB).

NOTE 2: Correction Factor = Antenna gain of substitution antenna- TX cable loss



A D T

MODE	Mid. channel	FREQUENCY RANGE	Below 1000MHz
INPUT POWER	120Vac, 60Hz	ENVIRONMENTAL CONDITIONS	23degoC, 62%RH 991hPa
CHANNEL BANDWIDTH	10MHz	TEST MODE	A
TESTED BY	Mark Liao		

ANTENNA POLARITY & TEST DISTANCE: HORIZONTAL AT 3m

NO.	FREQ. (MHz)	EMISSION LEVEL (dBuV)	LIMIT (dBm)	S.G POWER VALUE (dBm)	CORRECTION FACTOR (dB)	POWER VALUE (dBm)
1	127.11	34.4	-25.0	-52.2	-7.7	-59.9
2	284.60	37.2	-25.0	-49.6	-7.7	-57.3
3	360.43	51.4	-25.0	-35.4	-7.8	-43.2
4	426.53	41.3	-25.0	-45.2	-7.8	-53.0
5	479.03	45.5	-25.0	-41.0	-7.8	-48.8
6	720.12	33.8	-25.0	-52.6	-7.9	-60.5

ANTENNA POLARITY & TEST DISTANCE: VERTICAL AT 3m

NO.	FREQ. (MHz)	EMISSION LEVEL (dBuV/m)	LIMIT (dBm)	S.G POWER VALUE (dBm)	CORRECTION FACTOR (dB)	POWER VALUE (dBm)
1	41.57	43.6	-25.0	-43.4	-7.7	-51.1
2	136.84	38.2	-25.0	-48.1	-7.7	-55.8
3	296.27	37.5	-25.0	-49.4	-7.7	-57.1
4	360.43	44.4	-25.0	-42.6	-7.8	-50.4
5	479.03	42.7	-25.0	-44.3	-7.8	-52.1
6	720.12	32.5	-25.0	-53.9	-7.9	-61.8

NOTE 1: Power Value (dBum) = S.G Power Value (dBm) + Correction Factor (dB).

NOTE 2: Correction Factor = Antenna gain of substitution antenna- TX cable loss



A D T

MODE	Mid. channel	FREQUENCY RANGE	Below 1000MHz
INPUT POWER	120Vac, 60Hz	ENVIRONMENTAL CONDITIONS	23degoC, 62%RH 991hPa
CHANNEL BANDWIDTH	10MHz	TEST MODE	B
TESTED BY	Mark Liao		

ANTENNA POLARITY & TEST DISTANCE: HORIZONTAL AT 3m						
NO.	FREQ. (MHz)	EMISSION LEVEL (dBuV)	LIMIT (dBm)	S.G POWER VALUE (dBm)	CORRECTION FACTOR (dB)	POWER VALUE (dBm)
1	72.77	48.1	-25.0	-38.9	-7.7	-46.6
2	148.58	47.8	-25.0	-38.8	-7.7	-46.5
3	220.50	54.4	-25.0	-32.1	-7.7	-39.8
4	360.46	54.2	-25.0	-32.4	-7.8	-40.2
5	480.98	52.3	-25.0	-34.4	-7.8	-42.2
6	836.71	49.0	-25.0	-37.5	-7.9	-45.4
ANTENNA POLARITY & TEST DISTANCE: VERTICAL AT 3m						
NO.	FREQ. (MHz)	EMISSION LEVEL (dBuV/m)	LIMIT (dBm)	S.G POWER VALUE (dBm)	CORRECTION FACTOR (dB)	POWER VALUE (dBm)
1	37.78	57.9	-25.0	-29.0	-7.7	-36.7
2	134.97	58.5	-25.0	-28.2	-7.7	-35.9
3	331.30	50.7	-25.0	-35.8	-7.8	-43.6
4	455.71	47.1	-25.0	-39.6	-7.8	-47.4
5	766.73	50.6	-25.0	-36.3	-7.9	-44.2
6	836.71	56.2	-25.0	-30.5	-7.9	-38.4

NOTE 1: Power Value (dBum) = S.G Power Value (dBm) + Correction Factor (dB).

NOTE 2: Correction Factor = Antenna gain of substitution antenna- TX cable loss

4.7 RADIATED EMISSION MEASUREMENT (ABOVE 1GHz)

4.7.1 LIMITS OF RADIATED EMISSION MEASUREMENT

In the FCC 27.53(m) (4), On any frequency outside a licensee's frequency block, the power of any emission shall be attenuated below the transmitter power (P) by at least $55 + 10 \log (P)$ dB. The limit of emission equal to -25 dBm.

4.7.2 TEST INSTRUMENTS

Same as 4.6.2

4.7.3 TEST PROCEDURES

- a. The power was measured with R&S Spectrum Analyzer. All measurements were done at 3 channels (low, middle and high channel of operational frequency range.)
- b. Substitution method is used for E.I.R.P measurement. In the semi-anechoic chamber, EUT placed on the 0.8m height of Turn Table, rotated the table around 360 degrees to search the maximum radiation power and receiver antenna shall be rotated vertical and horizontal polarization and moved height from 1m to 4m to find the maximum polar radiated power. The "Read Value" is the spectrum reading the maximum power value.
- c. The substitution antenna is substituted for EUT at the same position and signals generator export the CW signal to the substitution antenna via a TX cable. Rotated the Turn Table and moved receiving antenna to find the maximum radiation power. Adjust output power level of S.G to get a Value of spectrum reading equal to "Read Value " of step b. Record the power level of S.G
- d. $EIRP = \text{Output power level of S.G} - \text{TX cable loss} + \text{Antenna gain of substitution antenna.}$

NOTE: The resolution bandwidth and video bandwidth of test receiver/spectrum analyzer is 1MHz/3MHz

4.7.4 DEVIATION FROM TEST STANDARD

No deviation

4.7.5 TEST SETUP

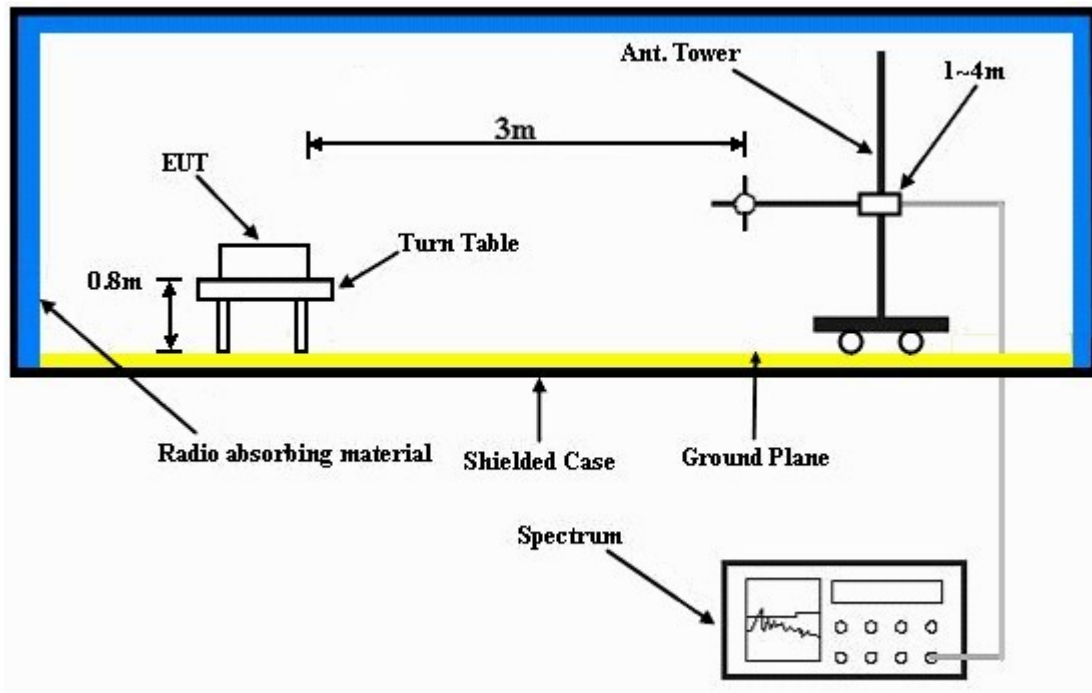

For the actual test configuration, please refer to the related item – Photographs of the Test Configuration.

4.7.6 EUT OPERATING CONDITIONS

Same as 4.6.6.



A D T

4.7.7 TEST RESULTS

MODE	Low channel	FREQUENCY RANGE	Above 1000MHz
INPUT POWER	120Vac, 60Hz	ENVIRONMENTAL CONDITIONS	23degoC, 62%RH 991hPa
CHANNEL BANDWIDTH	5MHz	TESTED BY	Mark Liao

ANTENNA POLARITY & TEST DISTANCE: HORIZONTAL AT 3m						
NO.	FREQ. (MHz)	EMISSION LEVEL (dBuV)	LIMIT (dBm)	S.G POWER VALUE (dBm)	CORRECTION FACTOR (dB)	POWER VALUE (dBm)
1	5003.0	47.3	-25.0	-56.4	9.5	-46.9
2	7504.5	51.5	-25.0	-50.4	7.8	-42.6
ANTENNA POLARITY & TEST DISTANCE: VERTICAL AT 3m						
NO.	FREQ. (MHz)	EMISSION LEVEL (dBuV)	LIMIT (dBm)	S.G POWER VALUE (dBm)	CORRECTION FACTOR (dB)	POWER VALUE (dBm)
1	5003.0	47.0	-25.0	-57.3	9.5	-47.8
2	7504.5	49.3	-25.0	-52.4	7.8	-44.6

NOTE 1: Power Value (dBm) = S.G Power Value (dBm) + Correction Factor (dB).

NOTE 2: Correction Factor = Antenna gain of substitution antenna- tx cable loss



A D T

MODE	Middle channel	FREQUENCY RANGE	Above 1000MHz
INPUT POWER	120Vac, 60Hz	ENVIRONMENTAL CONDITIONS	23degoC, 62%RH 991hPa
CHANNEL BANDWIDTH	5MHz	TESTED BY	Mark Liao

ANTENNA POLARITY & TEST DISTANCE: HORIZONTAL AT 3m						
NO.	FREQ. (MHz)	EMISSION LEVEL (dBuV)	LIMIT (dBm)	S.G POWER VALUE (dBm)	CORRECTION FACTOR (dB)	POWER VALUE (dBm)
1	5200.0	47.7	-25.0	-56.3	9.7	-46.6
2	7800.0	54.1	-25.0	-48.3	7.8	-40.5

ANTENNA POLARITY & TEST DISTANCE: VERTICAL AT 3m						
NO.	FREQ. (MHz)	EMISSION LEVEL (dBuV)	LIMIT (dBm)	S.G POWER VALUE (dBm)	CORRECTION FACTOR (dB)	POWER VALUE (dBm)
1	5200.0	55.8	-25.0	-48.2	9.7	-38.5
2	7800.0	52.0	-25.0	-50.4	7.8	-42.6

NOTE 1: Power Value (dBum) = S.G Power Value (dBm) + Correction Factor (dB).

NOTE 2: Correction Factor = Antenna gain of substitution antenna- tx cable loss



A D T

MODE	High channel	FREQUENCY RANGE	Above 1000MHz
INPUT POWER	120Vac, 60Hz	ENVIRONMENTAL CONDITIONS	23degoC, 62%RH 991hPa
CHANNEL BANDWIDTH	5MHz	TESTED BY	Mark Liao

ANTENNA POLARITY & TEST DISTANCE: HORIZONTAL AT 3m						
NO.	FREQ. (MHz)	EMISSION LEVEL (dBuV)	LIMIT (dBm)	S.G POWER VALUE (dBm)	CORRECTION FACTOR (dB)	POWER VALUE (dBm)
1	5375.0	45.4	-25.0	-58.4	9.7	-48.7
2	8062.5	66.4	-25.0	-35.6	7.8	-27.8

ANTENNA POLARITY & TEST DISTANCE: VERTICAL AT 3m						
NO.	FREQ. (MHz)	EMISSION LEVEL (dBuV)	LIMIT (dBm)	S.G POWER VALUE (dBm)	CORRECTION FACTOR (dB)	POWER VALUE (dBm)
1	5375.0	47.9	-25.0	-56.1	9.7	-46.4
2	8062.5	66.0	-25.0	-36.0	7.8	-28.2

NOTE 1: Power Value (dBum) = S.G Power Value (dBm) + Correction Factor (dB).

NOTE 2: Correction Factor = Antenna gain of substitution antenna- tx cable loss



A D T

MODE	Low channel	FREQUENCY RANGE	Above 1000MHz
INPUT POWER	120Vac, 60Hz	ENVIRONMENTAL CONDITIONS	23degoC, 62%RH 991hPa
CHANNEL BANDWIDTH	10MHz	TESTED BY	Mark Liao

ANTENNA POLARITY & TEST DISTANCE: HORIZONTAL AT 3m

NO.	FREQ. (MHz)	EMISSION LEVEL (dBuV)	LIMIT (dBm)	S.G POWER VALUE (dBm)	CORRECTION FACTOR (dB)	POWER VALUE (dBm)
1	5010.0	43.5	-25.0	-60.0	9.5	-50.5
2	7515.0	45.4	-25.0	-57.2	7.8	-49.4

ANTENNA POLARITY & TEST DISTANCE: VERTICAL AT 3m

NO.	FREQ. (MHz)	EMISSION LEVEL (dBuV)	LIMIT (dBm)	S.G POWER VALUE (dBm)	CORRECTION FACTOR (dB)	POWER VALUE (dBm)
1	5010.0	41.6	-25.0	-62.5	9.5	-53.0
2	7515.0	45.6	-25.0	-56.5	7.8	-48.7

NOTE 1: Power Value (dBm) = S.G Power Value (dBm) + Correction Factor (dB).

NOTE 2: Correction Factor = Antenna gain of substitution antenna- tx cable loss



A D T

MODE	Middle channel	FREQUENCY RANGE	Above 1000MHz
INPUT POWER	120Vac, 60Hz	ENVIRONMENTAL CONDITIONS	23degoC, 62%RH 991hPa
CHANNEL BANDWIDTH	10MHz	TESTED BY	Mark Liao

ANTENNA POLARITY & TEST DISTANCE: HORIZONTAL AT 3m						
NO.	FREQ. (MHz)	EMISSION LEVEL (dBuV)	LIMIT (dBm)	S.G POWER VALUE (dBm)	CORRECTION FACTOR (dB)	POWER VALUE (dBm)
1	5200.0	44.5	-25.0	-59.4	9.7	-49.7
2	7800.0	46.9	-25.0	-54.9	7.8	-47.1

ANTENNA POLARITY & TEST DISTANCE: VERTICAL AT 3m						
NO.	FREQ. (MHz)	EMISSION LEVEL (dBuV)	LIMIT (dBm)	S.G POWER VALUE (dBm)	CORRECTION FACTOR (dB)	POWER VALUE (dBm)
1	5200.0	51.2	-25.0	-52.5	9.7	-42.8
2	7800.0	47.0	-25.0	-55.5	7.8	-47.7

NOTE 1: Power Value (dBum) = S.G Power Value (dBm) + Correction Factor (dB).

NOTE 2: Correction Factor = Antenna gain of substitution antenna- tx cable loss



A D T

MODE	High channel	FREQUENCY RANGE	Above 1000MHz
INPUT POWER	120Vac, 60Hz	ENVIRONMENTAL CONDITIONS	23degoC, 62%RH 991hPa
CHANNEL BANDWIDTH	10MHz	TESTED BY	Mark Liao

ANTENNA POLARITY & TEST DISTANCE: HORIZONTAL AT 3m						
NO.	FREQ. (MHz)	EMISSION LEVEL (dBuV)	LIMIT (dBm)	S.G POWER VALUE (dBm)	CORRECTION FACTOR (dB)	POWER VALUE (dBm)
1	5370.0	41.5	-25.0	-63.0	9.7	-53.3
2	8055.0	55.7	-25.0	-46.9	7.8	-39.1

ANTENNA POLARITY & TEST DISTANCE: VERTICAL AT 3m						
NO.	FREQ. (MHz)	EMISSION LEVEL (dBuV)	LIMIT (dBm)	S.G POWER VALUE (dBm)	CORRECTION FACTOR (dB)	POWER VALUE (dBm)
1	5370.0	43.9	-25.0	-60.3	9.7	-50.6
2	8055.0	57.3	-25.0	-45.3	7.8	-37.5

NOTE 1: Power Value (dBum) = S.G Power Value (dBm) + Correction Factor (dB).

NOTE 2: Correction Factor = Antenna gain of substitution antenna- tx cable loss



A D T

5 PHOTOGRAPHS OF THE TEST CONFIGURATION

Please refer to the attached file (Test Setup Photo).



A D T

6 INFORMATION ON THE TESTING LABORATORIES

We, Bureau Veritas Consumer Products Services (H.K.) Ltd., Taoyuan Branch, were founded in 1988 to provide our best service in EMC, Radio, Telecom and Safety consultation. Our laboratories are accredited and approved according to ISO/IEC 17025.

Copies of accreditation certificates of our laboratories obtained from approval agencies can be downloaded from our web site:

www.adt.com.tw/index.5/phtml. If you have any comments, please feel free to contact us at the following:

Linko EMC/RF Lab:

Tel: 886-2-26052180

Fax: 886-2-26051924

Hsin Chu EMC/RF Lab:

Tel: 886-3-5935343

Fax: 886-3-5935342

Hwa Ya EMC/RF/Safety/Telecom Lab: Web Site: www.adt.com.tw

Tel: 886-3-3183232

Fax: 886-3-3185050

The address and road map of all our labs can be found in our web site also.

---END---