

FCC Test Report

FCC ID : MXF-WLTFQR121GN
Equipment : LTE router
Model No. : WLTFQR-121GN
Brand Name : Gemtek
Applicant : Gemtek Technology Co., Ltd.
Address : No. 15-1 Zhonghua Road, Hsinchu Industrial
Park, Hukou, Hsinchu, Taiwan, 30352.
Standard : 47 CFR FCC Part 27 Subpart B
Received Date : Jun. 14, 2014
Tested Date : Jun. 23 ~ Jun. 27, 2014

We, International Certification Corp., would like to declare that the tested sample has been evaluated and in compliance with the requirement of the above standards. The test results contained in this report refer exclusively to the product. It may be duplicated completely for legal use with the approval of the applicant. It shall not be reproduced except in full without the written approval of our laboratory.

Approved & Reviewed by:

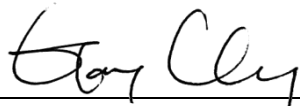

Gary Chang / Manager



Testing Laboratory
2732

Table of Contents

1	GENERAL DESCRIPTION	5
1.1	Information.....	5
1.2	Local Support Equipment List	6
1.3	Test Setup Chart	6
1.4	The Equipment List	7
1.5	Test Standards	8
1.6	Measurement Uncertainty	8
2	TEST CONFIGURATION	9
2.1	Testing Condition and Location Information.....	9
2.2	The Worst Test Modes and Channel Details	9
3	TEST RESULTS.....	10
3.1	Effective Radiated Power	10
3.2	Radiated Emissions.....	14
3.3	Conducted Emissions.....	20
3.4	Band Edge.....	23
3.5	Occupied Bandwidth	34
3.6	Frequency Stability.....	37
3.7	Peak to Average Ratio	39
4	TEST LABORATORY INFORMATION	42

Release Record

Report No.	Version	Description	Issued Date
FW461401	Rev. 01	Initial issue	Aug. 04, 2014

Summary of Test Results

FCC Rules	Test Items	Measured	Result
2.1046 / 27.50(b)(10)	Effective Radiated Power	Power[dBm]: 20.30	Pass
2.1053 / 27.53(c)	Radiated Emissions	Meet the requirement of limit	Pass
2.1053 / 27.53(e)	Radiated Spurious Emission in the 1559-1610MHz band	Meet the requirement of limit	Pass
2.1051 / 27.53(c)	Conducted Emissions	Meet the requirement of limit	Pass
27.53 (c)	Band Edge	Meet the requirement of limit	Pass
2.1049 / 27.53	Occupied Bandwidth	Meet the requirement of limit	Pass
2.1055 / 27.54	Frequency Stability	Meet the requirement of limit	Pass
27.50(d)(5)	Peak to Average Ratio	Meet the requirement of limit	Pass

1 General Description

1.1 Information

1.1.1 Specification of the Equipment under Test (EUT)

Operating Frequency (MHz)	Channel Bandwidth: 5MHz: 779.5 ~ 784.5 Channel Bandwidth: 10MHz: 782
Modulation Type	Uplink : QPSK, 16QAM Downlink : QPSK, 16QAM, 64QAM
Duplex Mode	FDD
Release	9
Category	4
H/W Version	Daughter board (LTE module): WLTPEQ-102_V01 Mother board: WLTFQR-117GN_V01
S/W Version	01.01.02.025

1.1.2 Maximum ERP and Emission Designator

Mode	Modulation	Maximum ERP (W)	Emission Designator
LTE Band 13, CB: 5MHz	QPSK	0.107	4M53G7D
LTE Band 13, CB: 5MHz	16QAM	0.081	4M50W7D
LTE Band 13, CB: 10MHz	QPSK	0.105	9M03G7D
LTE Band 13, CB: 10MHz	16QAM	0.080	8M97W7D

1.1.3 Antenna Details

Ant. No.	Type	Gain (dBi)	Connector	Remark
1	omni-directional PCB Antenna	1.28	IPEX	---

1.1.4 EUT Operational Condition

Power Supply Type	12Vdc from adapter		
Operational Voltage	<input checked="" type="checkbox"/> Vnom (110 V)	<input checked="" type="checkbox"/> Vmax (126.5 V)	<input checked="" type="checkbox"/> Vmin (93.5 V)
Operational Climatic	<input checked="" type="checkbox"/> Tnom (20°C)	<input checked="" type="checkbox"/> Tmax (50°C)	<input checked="" type="checkbox"/> Tmin (-30°C)

1.1.5 Operating Channel List

LTE Band 13		
Channel Bandwidth (MHz)	Channel	Frequency (MHz)
5	23205	779.5
5	23230	782.0
5	23255	784.5
10	23230	782.0

1.2 Local Support Equipment List

Support Equipment List					
No.	Equipment	Brand	Model	FCC ID	Signal cable / Length (m)
1	Notebook	DELL	E6430	DoC	RJ45, 10m non-shielded w/o core. RJ45, 1.5m non-shielded w/o core.

1.3 Test Setup Chart

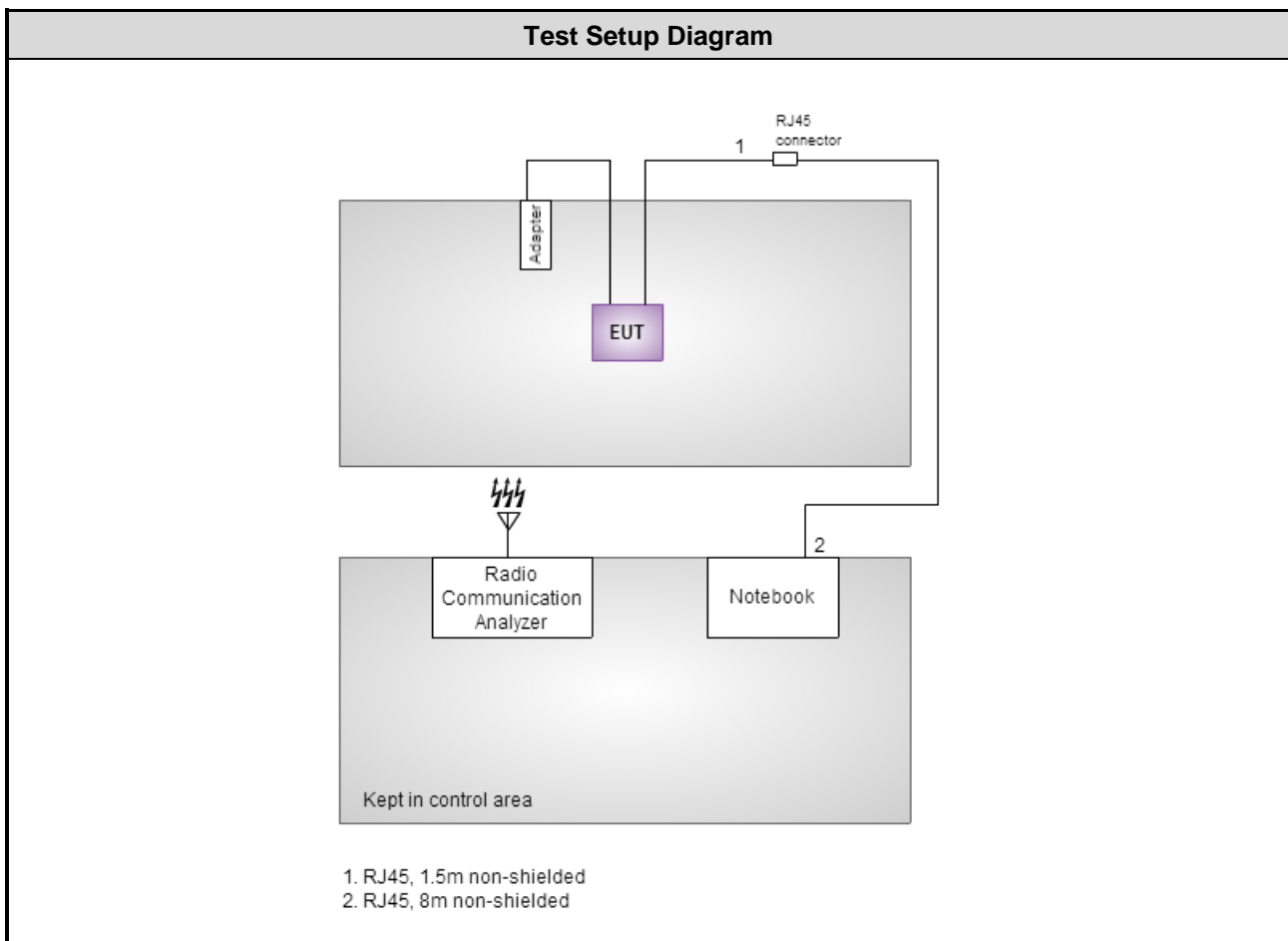

1.4 The Equipment List

Test Item	Radiated Emission				
Test Site	966 chamber1 / (03CH01-WS)				
Instrument	Manufacturer	Model No.	Serial No.	Calibration Date	Calibration Until
Spectrum Analyzer	R&S	FSV40	101498	Jan. 25, 2014	Jan. 24, 2015
Receiver	R&S	ESR3	101658	Jan. 10, 2014	Jan. 09, 2015
Bilog Antenna	SCHWARZBECK	VULB9168	VULB9168-522	Jan. 02, 2014	Jan. 01, 2015
Horn Antenna 1G-18G	SCHWARZBECK	BBHA 9120 D	BBHA 9120 D 1096	Feb. 13, 2014	Feb. 12, 2015
Horn Antenna 18G-40G	SCHWARZBECK	BBHA 9170	BBHA 9170517	Dec. 27, 2013	Dec. 26, 2014
Preamplifier	Burgeon	BPA-530	100219	Nov. 28, 2013	Nov. 27, 2014
Preamplifier	Agilent	83017A	MY39501308	Dec. 16, 2013	Dec. 15, 2014
Preamplifier	WM	TF-130N-R1	923365	Oct. 23, 2013	Oct. 22, 2014
RF Cable	HUBER+SUHNER	SUCOFLEX104	MY16014/4	Dec. 16, 2013	Dec. 15, 2014
RF Cable	HUBER+SUHNER	SUCOFLEX104	MY16019/4	Dec. 16, 2013	Dec. 15, 2014
RF Cable	HUBER+SUHNER	SUCOFLEX104	MY16139/4	Dec. 16, 2013	Dec. 15, 2014
LF cable 3M	Woken	CFD400NL-LW	CFD400NL-001	Dec. 16, 2013	Dec. 15, 2014
LF cable 10M	Woken	CFD400NL-LW	CFD400NL-002	Dec. 16, 2013	Dec. 15, 2014

Note: Calibration Interval of instruments listed above is one year.

Loop Antenna	R&S	HFH2-Z2	100330	Nov. 15, 2012	Nov. 14, 2014
--------------	-----	---------	--------	---------------	---------------

Note: Calibration Interval of instruments listed above is two year.

Test Item	RF Conducted				
Test Site	(TH01-WS)				
Instrument	Manufacturer	Model No.	Serial No.	Calibration Date	Calibration Until
Spectrum Analyzer	R&S	FSV40	101063	Feb. 17, 2014	Feb. 16, 2015
TEMP&HUMIDITY CHAMBER	GIANT FORCE	GCT-225-40-SP-SD	MAF1212-002	Dec. 11, 2013	Dec. 10, 2014
Power Meter	Anritsu	ML2495A	1241002	Oct. 24, 2013	Oct. 23, 2014
Power Sensor	Anritsu	MA2411B	1207366	Oct. 24, 2013	Oct. 23, 2014
Radio Communication Analyzer	Anritsu	MT8820C	6201240341	Mar. 18, 2014	Mar. 17, 2015

Note: Calibration Interval of instruments listed above is one year.

1.5 Test Standards

According to the specification of EUT, the EUT must comply with following standards.

47 CFR FCC Part 27 Subpart B

47 CFR FCC Part 2

ANSI C63.4-2003

ANSI / TIA / EIA-603-C -2004

KDB 971168 D01 Power Meas License Digital Systems v02r01

KDB 412172 D01 Determining ERP and EIRP v01

1.6 Measurement Uncertainty

ISO/IEC 17025 requires that an estimate of the measurement uncertainties associated with the emissions test results be included in the report. The measurement uncertainties given below are based on a 95% confidence level (based on a coverage factor ($k=2$))

Measurement Uncertainty	
Parameters	Uncertainty
Bandwidth	± 34.134 Hz
Conducted power	± 0.808 dB
Frequency error	± 34.134 Hz
Temperature	± 0.6 °C
Conducted emission	± 2.670 dB
AC conducted emission	± 2.92 dB
Radiated emission ≤ 1 GHz	± 3.26 dB
Radiated emission > 1 GHz	± 4.94 dB

2 Test Configuration

2.1 Testing Condition and Location Information

Test Item	Test Site	Ambient Condition	Tested By
Radiated Emissions	03CH01-WS	25°C / 65%	Haru Yang
RF Conducted	TH01-WS	24°C / 65%	Felix Sung

➤ FCC site registration No.: 657002

➤ IC site registration No.: 10807A-1

2.2 The Worst Test Modes and Channel Details

Test item	Channel Bandwidth	Modulation	Test channel
E.R.P Conducted Emissions Occupied Bandwidth Peak to Average Ratio	5 MHz 10 MHz	QPSK / 16QAM QPSK / 16QAM	23205 / 23230 / 23255 23230
Radiated Emission ≤ 1GHz	5 MHz 10 MHz	QPSK QPSK	23230 23230
Radiated Emission > 1GHz	5 MHz 10 MHz	QPSK QPSK	23205 / 23230 / 23255 23230
Band Edge	5 MHz 10 MHz	QPSK / 16QAM QPSK / 16QAM	23205 / 23255 23230
Frequency Stability	5 MHz 10 MHz	QPSK QPSK	23230 23230

NOTE:

1. Adapter 1 and Adapter 2 had been pretested and found that **Adapter 2** was the worst case and was selected for final testing (Adapter 1: OEM adapter; Adapter 2: APD adapter).

3 Test Results

3.1 Effective Radiated Power

3.1.1 Limit of Effective Radiated Power

Portable stations (hand-held devices) transmitting in the 746~757 MHz, 758~763 MHz, 776~793MHz, and 805~806 MHz bands are limited to 3 watts ERP.

3.1.2 Test Procedures

1. Measurement is made at a semi-anechoic chamber that incorporates a turntable allowing a EUT rotation of 360°. A continuously-rotating, remotely-controlled turntable is installed at the test site to support the EUT and facilitate determination of the direction of maximum radiation for each EUT emission frequency. The EUT is placed at a height of 0.8 m test table above the ground plane.
2. Measurement is made with the antenna positioned in both the horizontal and vertical planes of polarization. The measurement antenna is varied in height (1m ~ 4m) above the reference ground plane to obtain the maximum signal strength. Distance between EUT and antenna is 3 m.
3. This investigation is performed with the EUT rotated 360°, the antenna height scanned between 1 m and 4 m, and the antenna rotated to repeat the measurements for both the horizontal and vertical antenna polarizations.
4. After finding the max radiated emission, substitution method will be used for getting effective radiated power. EUT will be removed and substitution antenna will be placed at same position. Signal generator will output CW signal to substitution antenna through a RF cable. Rotate turntable and move antenna to find maximum radiated emission. Adjust output power of signal generator to let the maximum radiated emission is same as step 3. Record the output power level.
5. E.I.R.P = output power of step 4 + gain of substitution antenna – cable loss of RF cable. ERP can be calculated by below formula:
$$E.R.P = E.I.R.P - 2.15dB$$

For Conducted power measurement

1. The EUT links up with simulator and is set to maximum output power level at low / middle / high channel.
2. Measure the output power of low / middle / high channel of the EUT

3.1.3 Test Setup

Effective Radiated Power Measurement

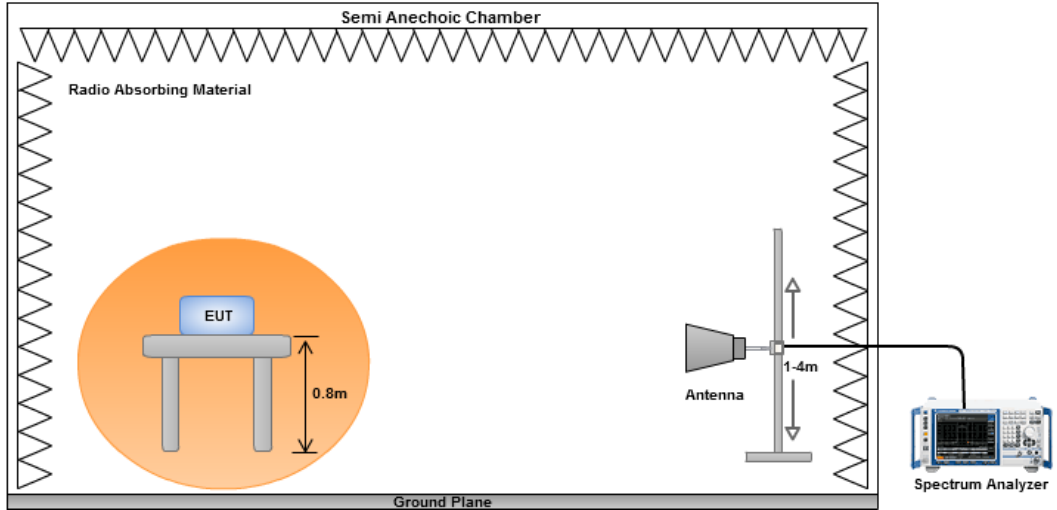

Conducted Power Measurement

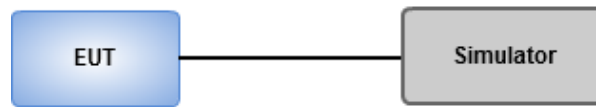

3.1.4 Test Result of Conducted power (dBm)

Band / Channel Bandwidth			LTE Band 13 / CB: 5MHz		
Channel			23205	23230	23255
Frequency (MHz)			779.5	782	784.5
Mode	RB	RB Offset	Maximum AV Power (dBm)		
QPSK	1	0	22.69	22.73	22.64
	1	24	22.53	22.59	22.58
	12	6	21.56	21.55	21.68
	25	0	21.50	21.52	21.53
16QAM	1	0	21.76	21.68	21.64
	1	24	21.54	21.63	21.58
	12	6	20.51	20.54	20.65
	25	0	20.52	20.50	20.53

Band / Channel Bandwidth			LTE Band 13 / CB: 10MHz		
Channel			23230	---	---
Frequency (MHz)			782	---	---
Mode	RB	RB Offset	Maximum AV Power (dBm)		
QPSK	1	0	22.72	---	---
	1	49	22.66	---	---
	25	12	21.52	---	---
	50	0	21.51	---	---
16QAM	1	0	21.85	---	---
	1	49	21.69	---	---
	25	12	20.59	---	---
	50	0	20.53	---	---

3.1.5 Test Result of Effective Radiated Power (dBm)

Mode	CB: 5MHz, 1RB, Offset 0, QPSK						
Channel	Frequency (MHz)	ERP (dBm)	Limit (dBm)	Margin (dB)	S.A Reading (dBm)	S.G Power Vaule (dBm)	Correction Factor (dB)
23205	779.5	20.30	34.8	-14.50	-9.30	19.20	3.25
23230	782.0	19.71	34.8	-15.09	-9.87	18.62	3.24
23255	784.5	19.59	34.8	-15.21	-9.98	18.51	3.23

Mode	CB: 5MHz, 1RB, Offset 0, 16QAM						
Channel	Frequency (MHz)	ERP (dBm)	Limit (dBm)	Margin (dB)	S.A Reading (dBm)	S.G Power Vaule (dBm)	Correction Factor (dB)
23205	779.5	19.08	34.8	-15.72	-10.52	17.98	3.25
23230	782	18.64	34.8	-16.16	-10.94	17.55	3.24
23255	784.5	18.43	34.8	-16.37	-11.14	17.35	3.23

NOTE: ERP = S.G power value + correction factor - 2.15

Mode	CB: 10MHz, 1RB, Offset 0, QPSK						
Channel	Frequency (MHz)	ERP (dBm)	Limit (dBm)	Margin (dB)	S.A Reading (dBm)	S.G Power Vaule (dBm)	Correction Factor (dB)
23230	782.0	20.22	34.8	-14.58	-9.36	19.13	3.24

Mode	CB: 10MHz, 1RB, Offset 0, 16QAM						
Channel	Frequency (MHz)	ERP (dBm)	Limit (dBm)	Margin (dB)	S.A Reading (dBm)	S.G Power Vaule (dBm)	Correction Factor (dB)
23230	782	19.04	34.8	-15.76	-10.54	17.95	3.24

NOTE: ERP = S.G power value + correction factor - 2.15

3.2 Radiated Emissions

3.2.1 Limit of Radiated Emissions

The power of any emission outside of the authorized operating frequency ranges must be attenuated below the transmitting power (P) by a factor of at least $43 + 10 \log(P)$ dB equal to -13dBm. Emissions in the band 1559-1610 MHz shall be limited to -70 dBW/MHz equivalent isotropically radiated power (EIRP)

3.2.2 Test Procedures

1. Measurement is made at a semi-anechoic chamber that incorporates a turntable allowing a EUT rotation of 360°. A continuously-rotating, remotely-controlled turntable is installed at the test site to support the EUT and facilitate determination of the direction of maximum radiation for each EUT emission frequency. The EUT is placed at a height of 0.8 m test table above the ground plane.
2. Measurement is made with the antenna positioned in both the horizontal and vertical planes of polarization. The measurement antenna is varied in height (1m ~ 4m) above the reference ground plane to obtain the maximum signal strength. Distance between EUT and antenna is 3 m.
3. This investigation is performed with the EUT rotated 360°, the antenna height scanned between 1 m and 4 m, and the antenna rotated to repeat the measurements for both the horizontal and vertical antenna polarizations.
4. After finding the max radiated emission, substitution method will be used for getting effective radiated power. EUT will be removed and substitution antenna will be placed at same position. Signal generator will output CW signal to substitution antenna through a RF cable. Rotate turntable and move antenna to find maximum radiated emission. Adjust output power of signal generator to let the maximum radiated emission is same as step 3. Record the output power level.
5. E.I.R.P = output power of step 4 + gain of substitution antenna – cable loss of RF cable. ERP can be calculated by below formula:
 $E.R.P = E.I.R.P - 2.15dB$

3.2.3 Test Setup

Radiated Emissions below 1 GHz

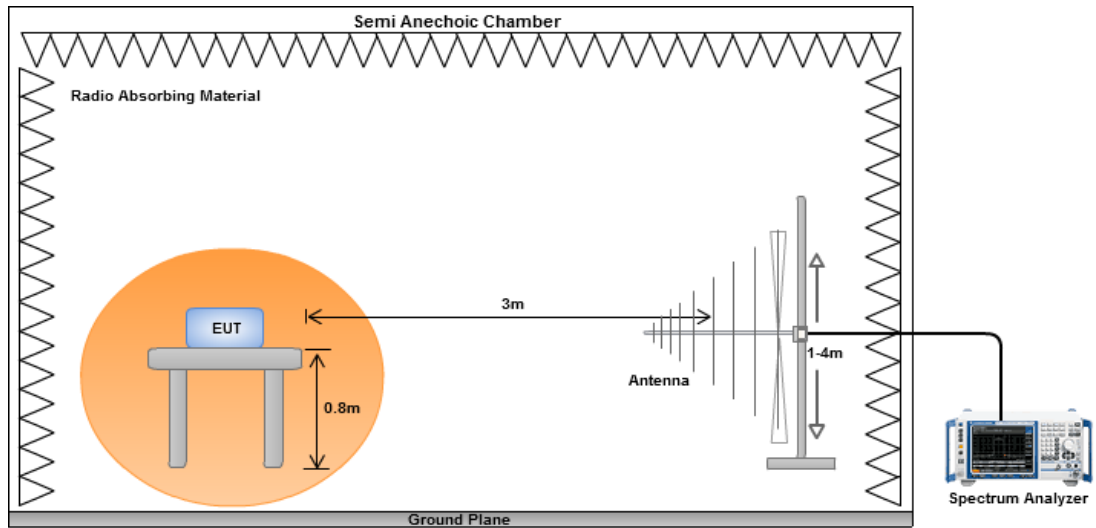

Radiated Emissions above 1 GHz

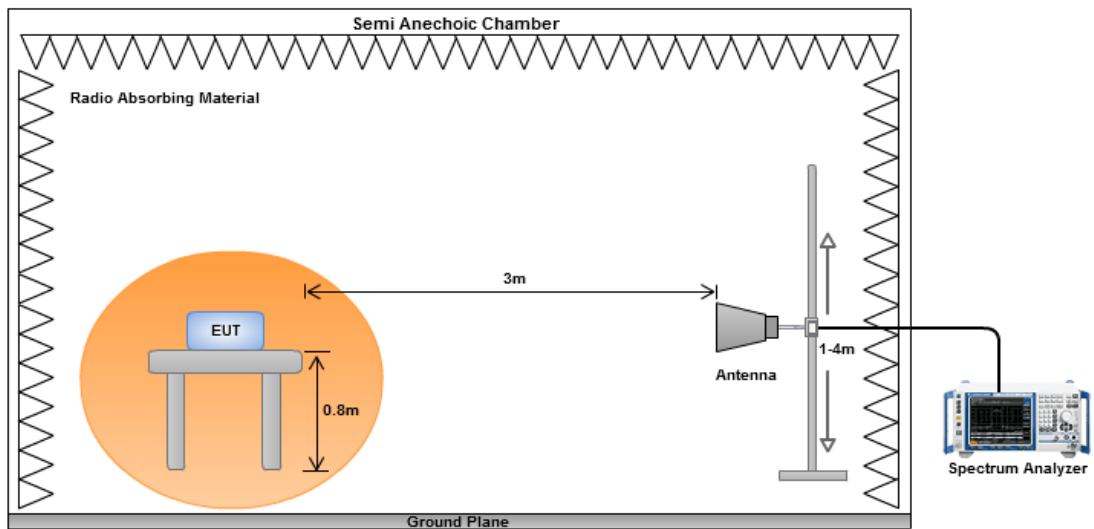

3.2.4 Test Result of Radiated Emissions below 1GHz

Mode							
LTE Band 13, CB: 5MHz, 1RB, Offset 0, Channel : 23230							
Frequency (MHz)	Antenna Polarity	E.R.P (dBm)	Limit (dBm)	Margin (dB)	S.A Reading (dBm)	S.G Power Vaule (dBm)	Correction Factor (dB)
124.09	H	-55.73	-13.00	-42.73	-43.65	-52.74	-0.84
154.16	H	-55.02	-13.00	-42.02	-44.01	-51.87	-1.00
298.69	H	-53.95	-13.00	-40.95	-42.15	-56.00	4.20
490.75	H	-62.14	-13.00	-49.14	-55.35	-64.09	4.10
583.87	H	-60.12	-13.00	-47.12	-54.47	-61.87	3.90
700.27	H	-56.02	-13.00	-43.02	-51.71	-57.65	3.78
42.52	V	-54.40	-13.00	-41.40	-43.04	-40.31	-11.94
142.52	V	-50.21	-13.00	-37.21	-40.98	-46.77	-1.29
183.26	V	-55.16	-13.00	-42.16	-45.88	-55.50	2.49
301.60	V	-56.34	-13.00	-43.34	-47.97	-58.40	4.21
426.73	V	-57.11	-13.00	-44.11	-49.47	-59.14	4.18
916.58	V	-58.72	-13.00	-45.72	-59.19	-59.37	2.80

NOTE: ERP = S.G power value + correction factor - 2.15

Mode							
LTE Band 13, CB: 10MHz, 1RB, Offset 0, Channel : 23230							
Frequency (MHz)	Antenna Polarity	E.R.P (dBm)	Limit (dBm)	Margin (dB)	S.A Reading (dBm)	S.G Power Vaule (dBm)	Correction Factor (dB)
136.70	H	-57.43	-13.00	-44.43	-46.26	-54.04	-1.24
183.26	H	-56.13	-13.00	-43.13	-43.26	-56.47	2.49
296.75	H	-58.96	-13.00	-45.96	-47.10	-61.02	4.21
387.93	H	-61.45	-13.00	-48.45	-53.24	-63.62	4.32
700.27	H	-60.40	-13.00	-47.40	-56.09	-62.03	3.78
934.04	H	-59.47	-13.00	-46.47	-58.66	-60.04	2.72
107.60	V	-54.78	-13.00	-41.78	-43.44	-52.53	-0.10
183.26	V	-56.98	-13.00	-43.98	-47.70	-57.32	2.49
399.57	V	-57.40	-13.00	-44.40	-49.30	-59.54	4.29
485.90	V	-60.38	-13.00	-47.38	-54.09	-62.33	4.10
700.27	V	-60.94	-13.00	-47.94	-59.32	-62.57	3.78
834.13	V	-59.34	-13.00	-46.34	-58.16	-60.20	3.01

NOTE: ERP = S.G power value + correction factor - 2.15

3.2.5 Test Result of Radiated Emissions above 1GHz

Mode							
LTE Band 13, CB: 5MHz, 1RB, Offset 0, Channel : 23205							
Frequency (MHz)	Antenna Polarity	E.R.P (dBm)	Limit (dBm)	Margin (dB)	S.A Reading (dBm)	S.G Power Vaule (dBm)	Correction Factor (dB)
1166.68	H	-45.26	-13.00	-32.26	-44.58	-46.45	3.34
1554.78	H	-46.50	-13.00	-33.50	-47.57	-49.08	4.73
2332.21	H	-51.36	-13.00	-38.36	-57.18	-55.33	6.12
3109.64	H	-53.89	-13.00	-40.89	-62.84	-57.86	6.12
1166.68	V	-47.58	-13.00	-34.58	-45.39	-48.77	3.34
1554.78	V	-44.62	-13.00	-31.62	-45.06	-47.20	4.73
2332.21	V	-48.90	-13.00	-35.90	-55.87	-52.87	6.12
3109.64	V	-54.49	-13.00	-41.49	-62.47	-58.46	6.12

Mode							
LTE Band 13, CB: 5MHz, 1RB, Offset 0, Channel : 23230							
Frequency (MHz)	Antenna Polarity	E.R.P (dBm)	Limit (dBm)	Margin (dB)	S.A Reading (dBm)	S.G Power Vaule (dBm)	Correction Factor (dB)
1166.68	H	-44.88	-13.00	-31.88	-44.20	-46.07	3.34
2339.56	H	-51.52	-13.00	-38.52	-57.34	-55.49	6.12
3119.24	H	-53.64	-13.00	-40.64	-62.62	-57.62	6.13
1166.68	V	-47.94	-13.00	-34.94	-45.75	-49.13	3.34
2339.56	V	-49.57	-13.00	-36.57	-56.50	-53.54	6.12
3119.24	V	-54.95	-13.00	-41.95	-62.97	-58.93	6.13

Mode							
LTE Band 13, CB: 5MHz, 1RB, Offset 0, Channel : 23255							
Frequency (MHz)	Antenna Polarity	E.R.P (dBm)	Limit (dBm)	Margin (dB)	S.A Reading (dBm)	S.G Power Vaule (dBm)	Correction Factor (dB)
1166.68	H	-44.35	-13.00	-31.35	-43.67	-45.54	3.34
2347.05	H	-51.91	-13.00	-38.91	-57.72	-55.88	6.12
3129.56	H	-53.34	-13.00	-40.34	-62.35	-57.34	6.15
1166.68	V	-47.46	-13.00	-34.46	-45.27	-48.65	3.34
2347.05	V	-49.96	-13.00	-36.96	-56.84	-53.93	6.12
3129.56	V	-54.47	-13.00	-41.47	-62.53	-58.47	6.15

NOTE: ERP = S.G power value + correction factor - 2.15

Mode	LTE Band 13, CB: 10MHz, 1RB, Offset 0, Channel : 23230						
Frequency (MHz)	Antenna Polarity	E.R.P (dBm)	Limit (dBm)	Margin (dB)	S.A Reading (dBm)	S.G Power Vaule (dBm)	Correction Factor (dB)
1166.68	H	-45.86	-13.00	-32.86	-45.18	-47.05	3.34
1555.26	H	-46.84	-13.00	-33.84	-47.91	-49.42	4.73
2332.68	H	-52.06	-13.00	-39.06	-57.88	-56.03	6.12
3110.17	H	-57.03	-13.00	-44.03	-65.98	-61.00	6.12
1166.68	V	-48.57	-13.00	-35.57	-46.38	-49.76	3.34
1555.26	V	-44.94	-13.00	-31.94	-45.38	-47.52	4.73
2332.68	V	-46.98	-13.00	-33.98	-53.94	-50.95	6.12
3110.17	V	-57.70	-13.00	-44.70	-65.68	-61.67	6.12

NOTE: ERP = S.G power value + correction factor - 2.15

3.2.6 Test Result of Radiated Emissions in the 1559-1610MHz band

Mode							
LTE Band 13, CB: 5MHz, 1RB, Offset 24, Channel : 23205							
Frequency (MHz)	Antenna Polarity	E.I.R.P. (dBm)	Limit (dBm)	Margin (dB)	S.A Reading (dBm)	S.G Power Vaule (dBm)	Correction Factor (dB)
1563.30	H	-44.84	-40.00	-4.84	-48.03	-49.60	4.76
1563.30	V	-41.53	-40.00	-1.53	-44.11	-46.29	4.76

Mode							
LTE Band 13, CB: 5MHz, 1RB, Offset 0, Channel : 23230							
Frequency (MHz)	Antenna Polarity	E.I.R.P. (dBm)	Limit (dBm)	Margin (dB)	S.A Reading (dBm)	S.G Power Vaule (dBm)	Correction Factor (dB)
1559.56	H	-44.59	-40.00	-4.59	-47.78	-49.33	4.74
1559.56	V	-42.71	-40.00	-2.71	-45.29	-47.45	4.74

Mode							
LTE Band 13, CB: 5MHz, 1RB, Offset 0, Channel : 23255							
Frequency (MHz)	Antenna Polarity	E.I.R.P. (dBm)	Limit (dBm)	Margin (dB)	S.A Reading (dBm)	S.G Power Vaule (dBm)	Correction Factor (dB)
1564.76	H	-44.43	-40.00	-4.43	-47.61	-49.19	4.76
1564.76	V	-42.74	-40.00	-2.74	-45.32	-47.50	4.76

Mode							
LTE Band 13, CB: 10MHz, 1RB, Offset 49, Channel : 23230							
Frequency (MHz)	Antenna Polarity	E.I.R.P. (dBm)	Limit (dBm)	Margin (dB)	S.A Reading (dBm)	S.G Power Vaule (dBm)	Correction Factor (dB)
1572.82	H	-45.29	-40.00	-5.29	-48.44	-50.08	4.79
1572.82	V	-43.06	-40.00	-3.06	-45.63	-47.85	4.79

3.3 Conducted Emissions

3.3.1 Limit of Conducted Emissions

On any frequency outside the 776~788 MHz band, the power of any emission shall be attenuated outside the band below the transmitter power (P) by at least $43 + 10 \log (P)$ dB equal to -13dBm.

3.3.2 Test Procedures

1. Lowest and highest operating channels are tested for this item.
2. Scan frequency range is from 30MHz~8GHz.
3. Set RBW = 1MHz, VBW = 3MHz, detector = RMS, sweep time = auto.
4. Record the max trace value and capture the test plot of each sub frequency band.

3.3.3 Test Setup

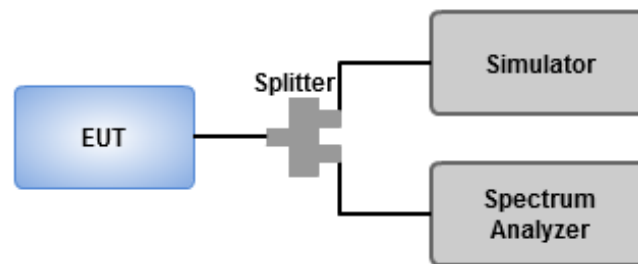

3.3.4 Test Result of Conducted Emissions

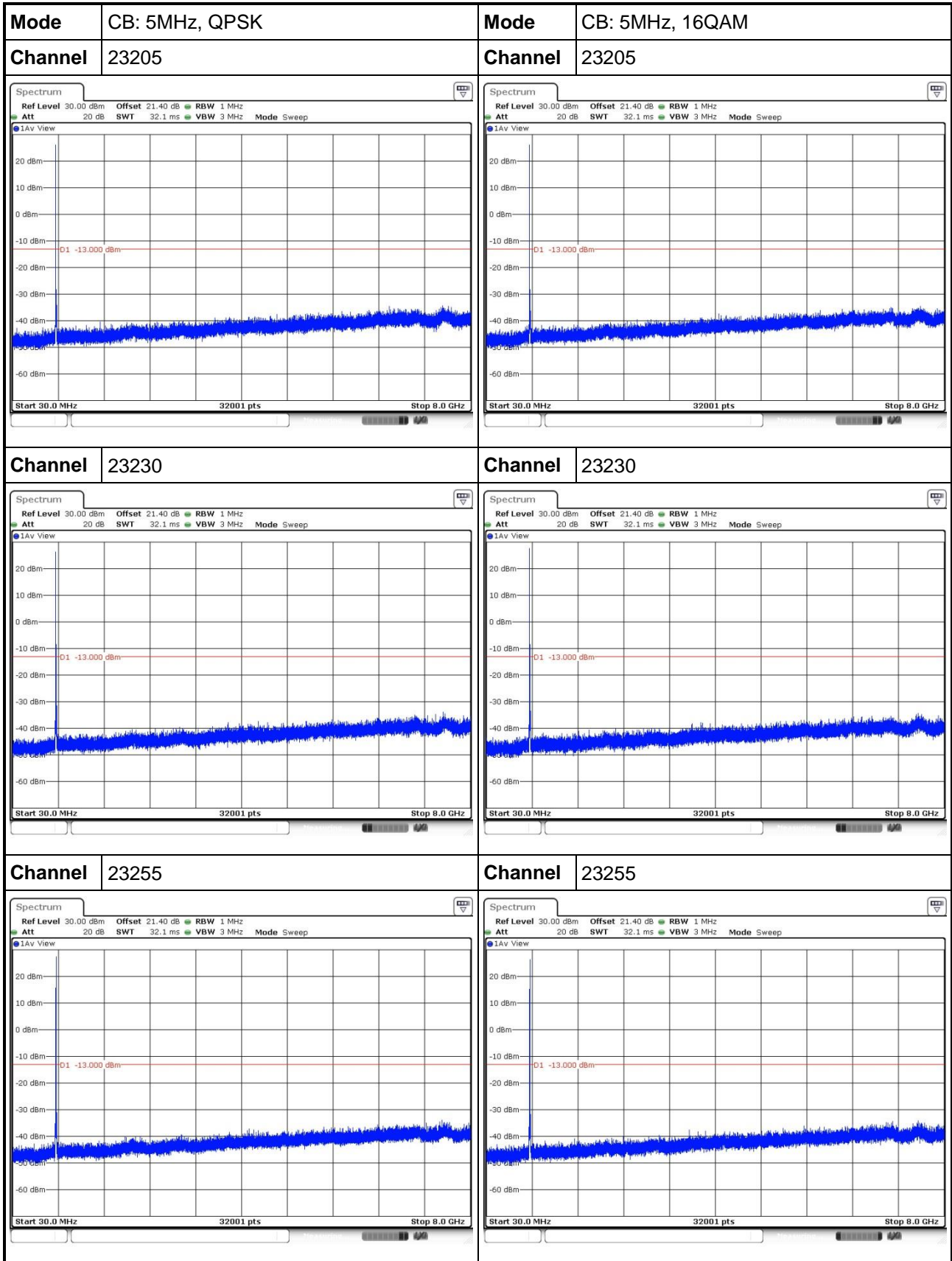

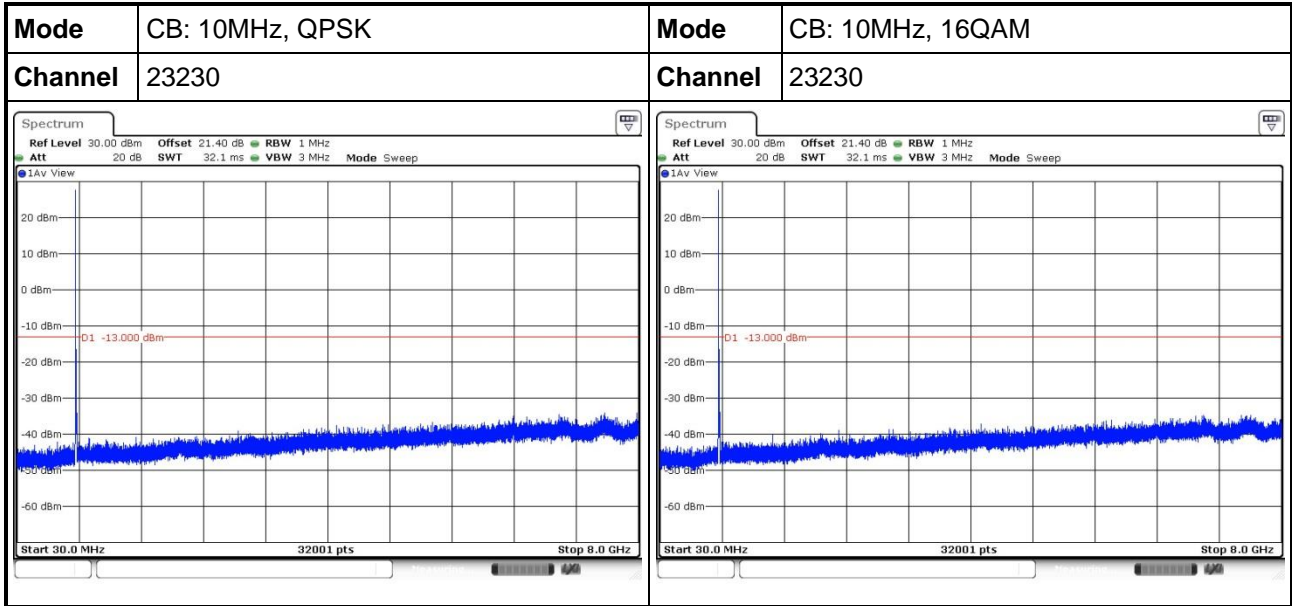

3.4 Band Edge

3.4.1 Limit of Band Edge

On any frequency outside the 776~788 MHz band, the power of any emission shall be attenuated outside the band below the transmitter power (P) by at least $43 + 10 \log(P)$ dB equal to -13dBm.

On all frequencies between 763~775 MHz and 793~805 MHz, by a factor not less than $65 + 10 \log(P)$ dB in a 6.25 kHz band segment, for mobile and portable stations.

3.4.2 Test Procedures

For frequency range 775~789 MHz

1. Set RBW = 100kHz, VBW = 300kHz, detector = RMS, sweep time = auto.
2. Record the max trace value and capture the test plot.

For frequency range 763~775 and 793~805 MHz

1. Set RBW = 10kHz, VBW = 30kHz, detector = RMS, sweep time = auto.
2. Record the max trace value and capture the test plot.

3.4.3 Test Setup

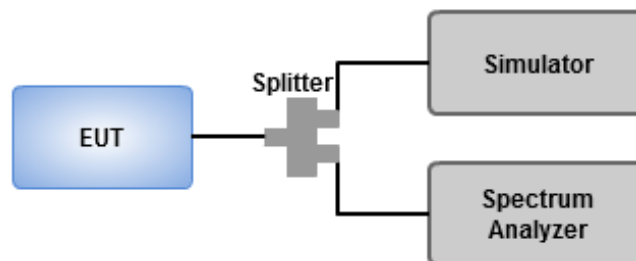

3.4.4 Test Result of 775~789 MHz

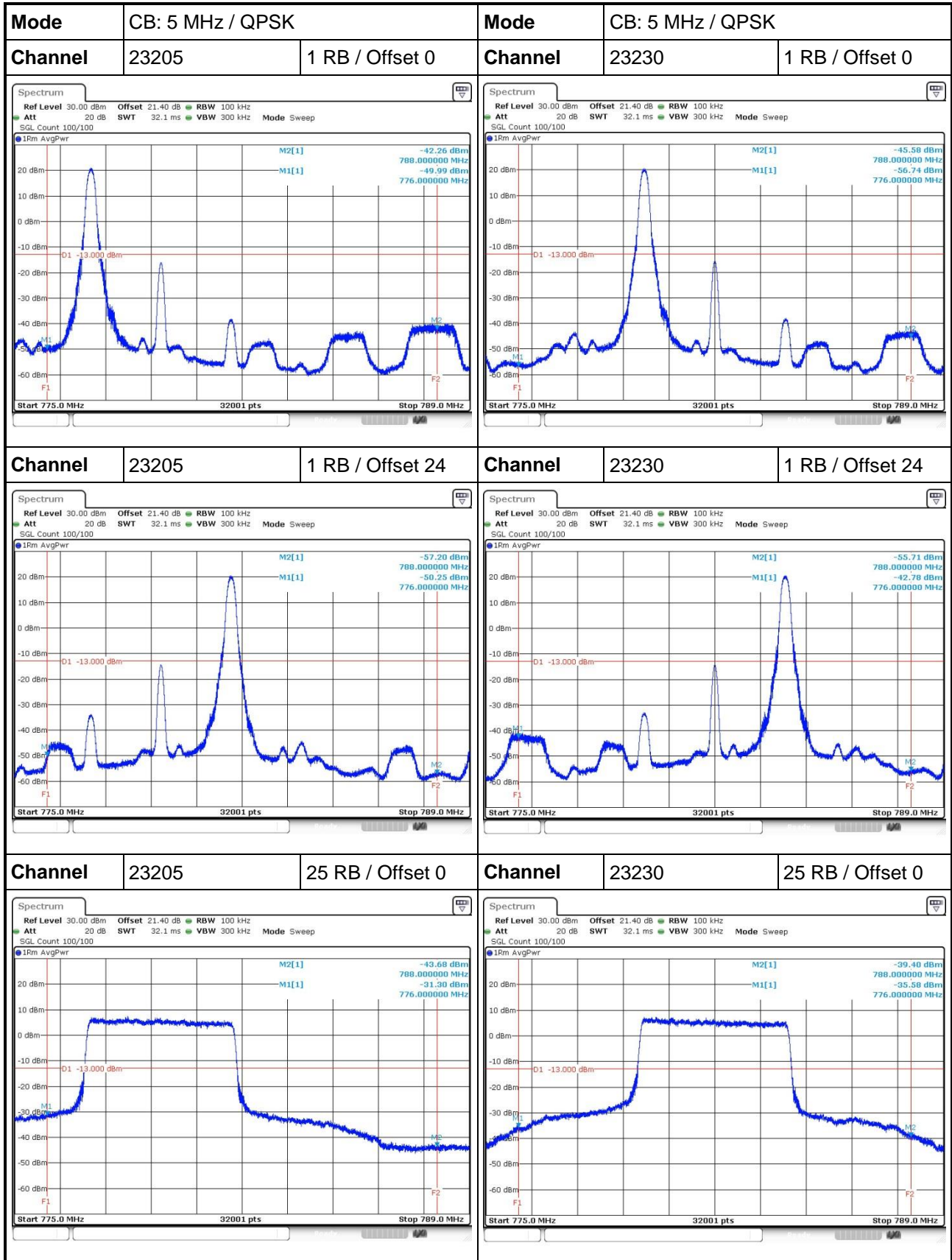

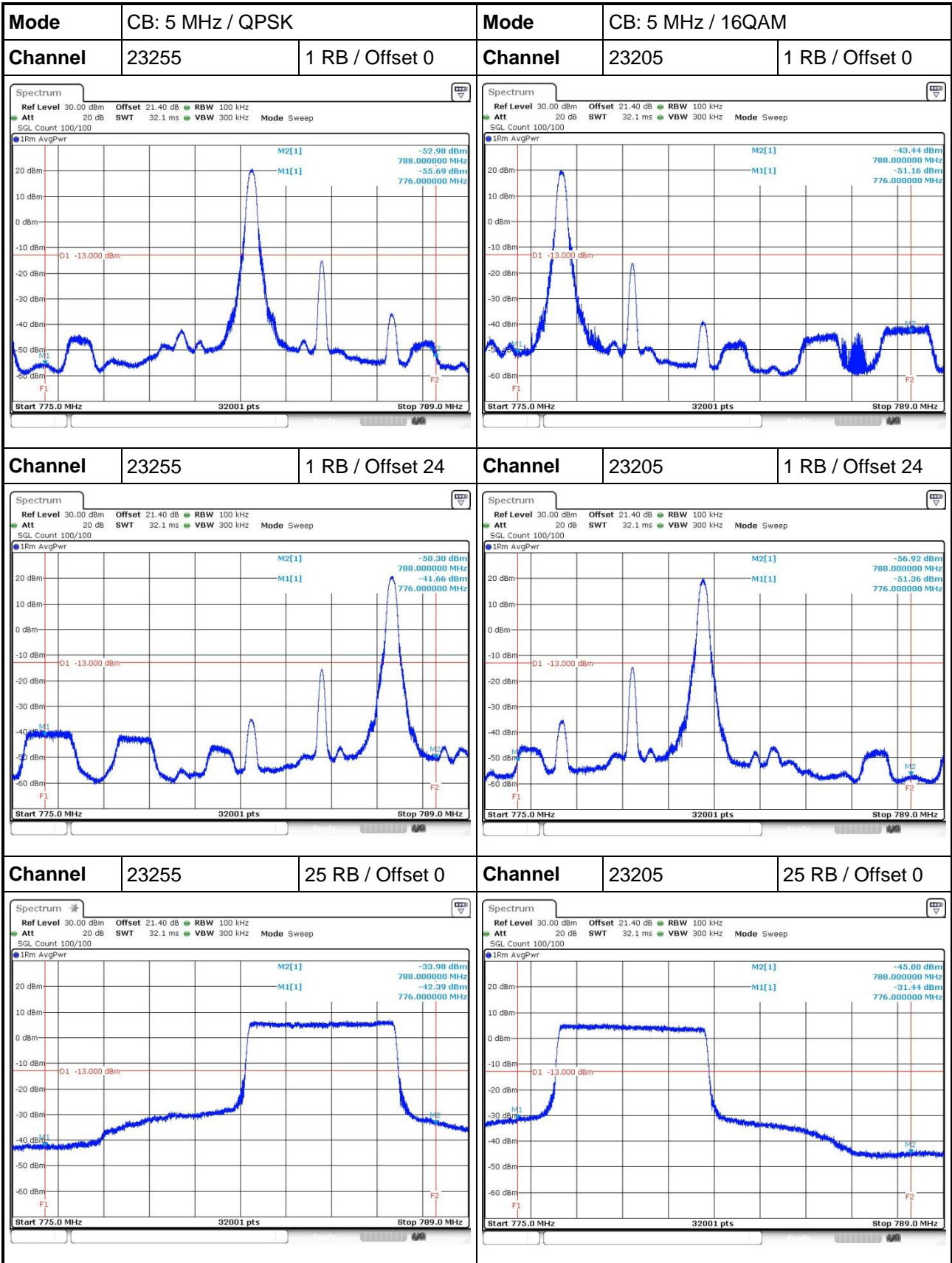

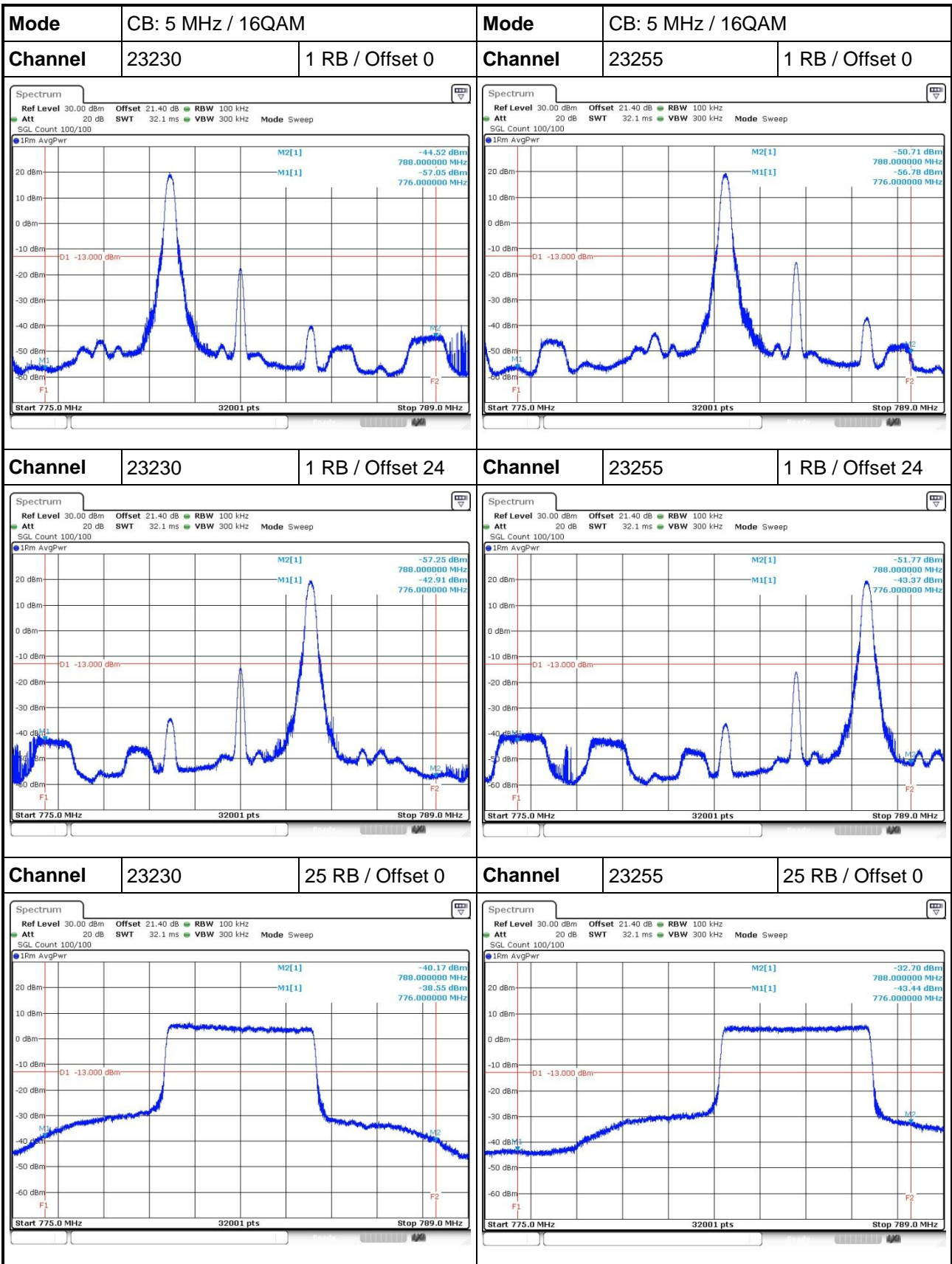

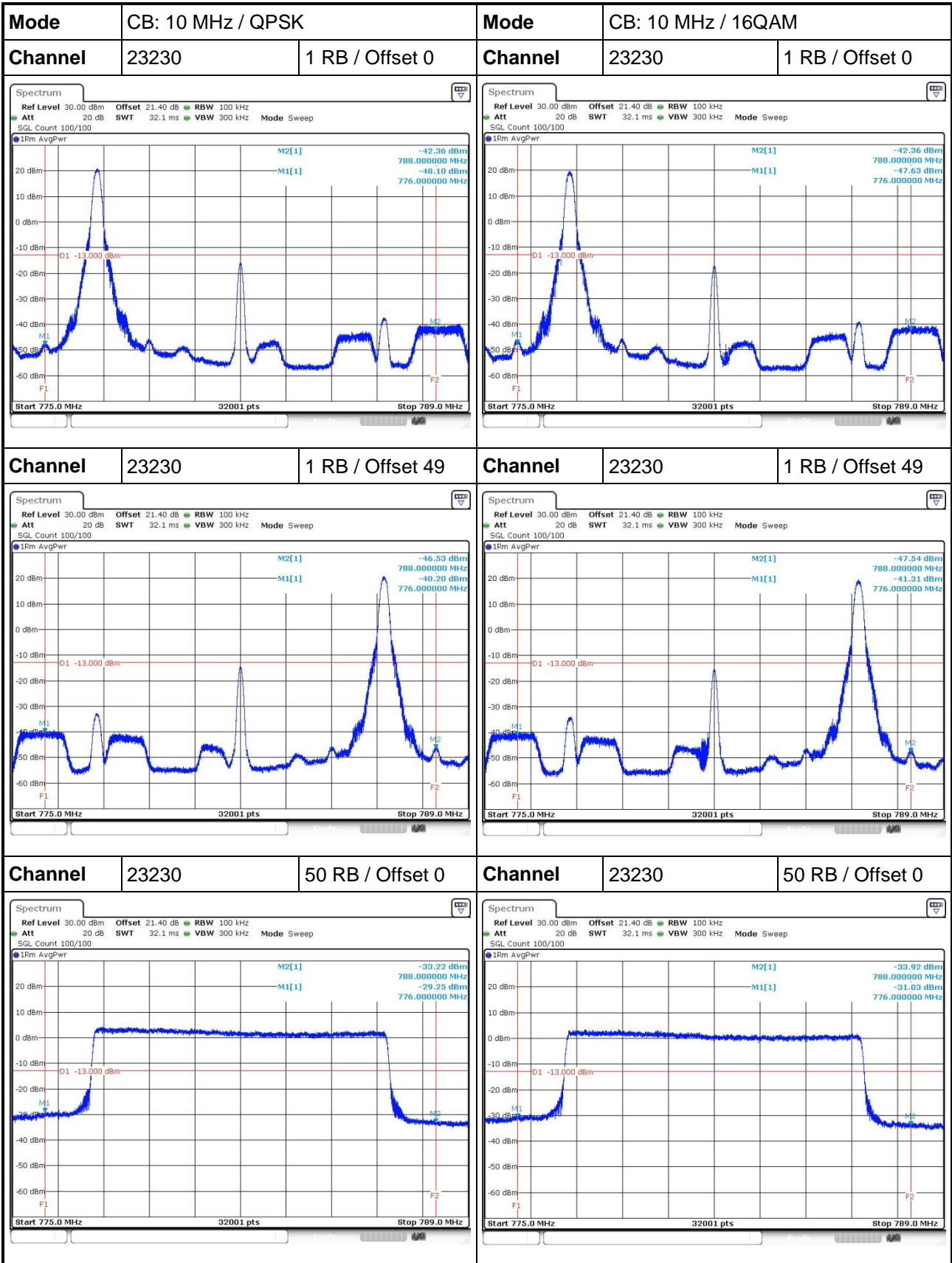

3.4.5 Test Result of 763~775 MHz

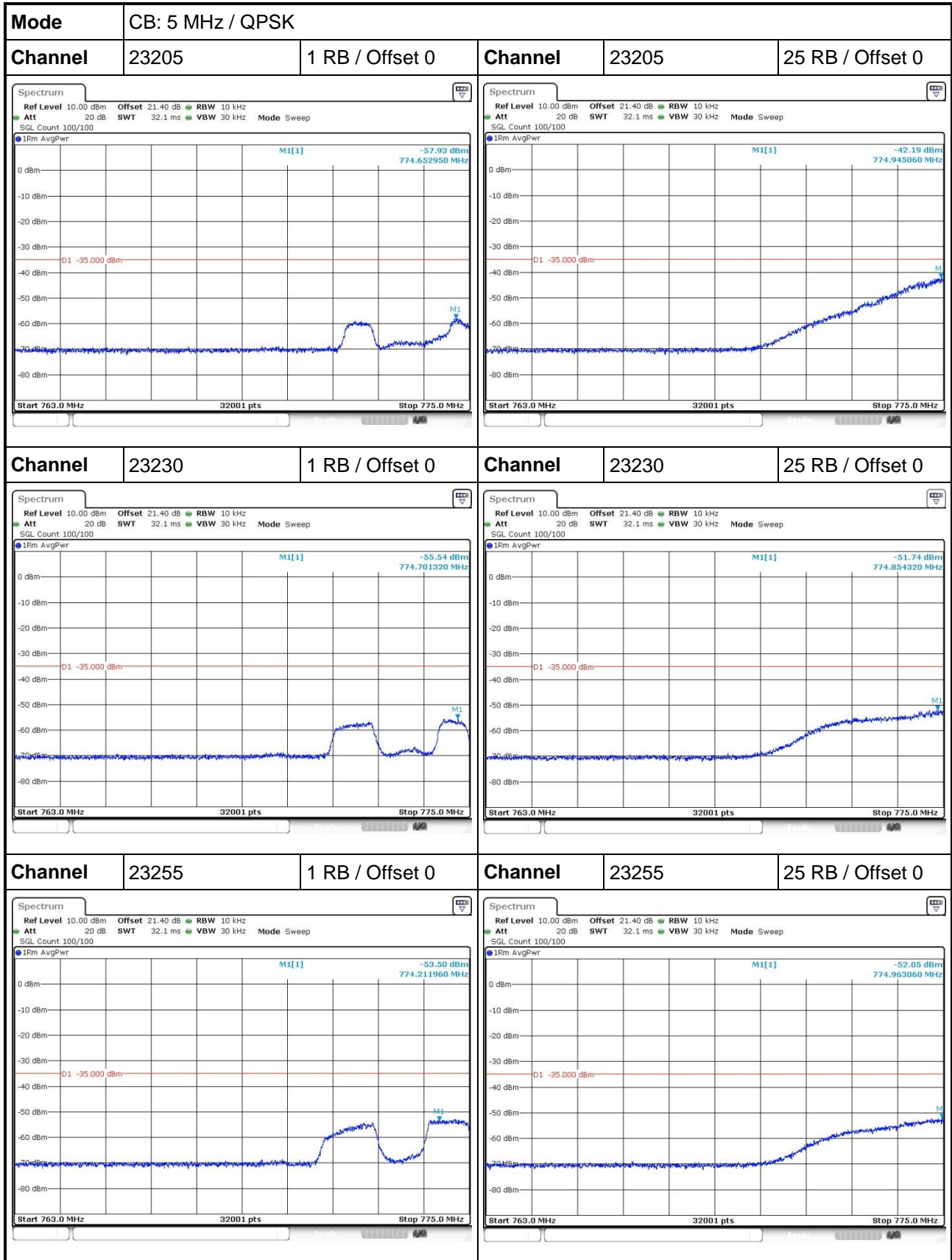

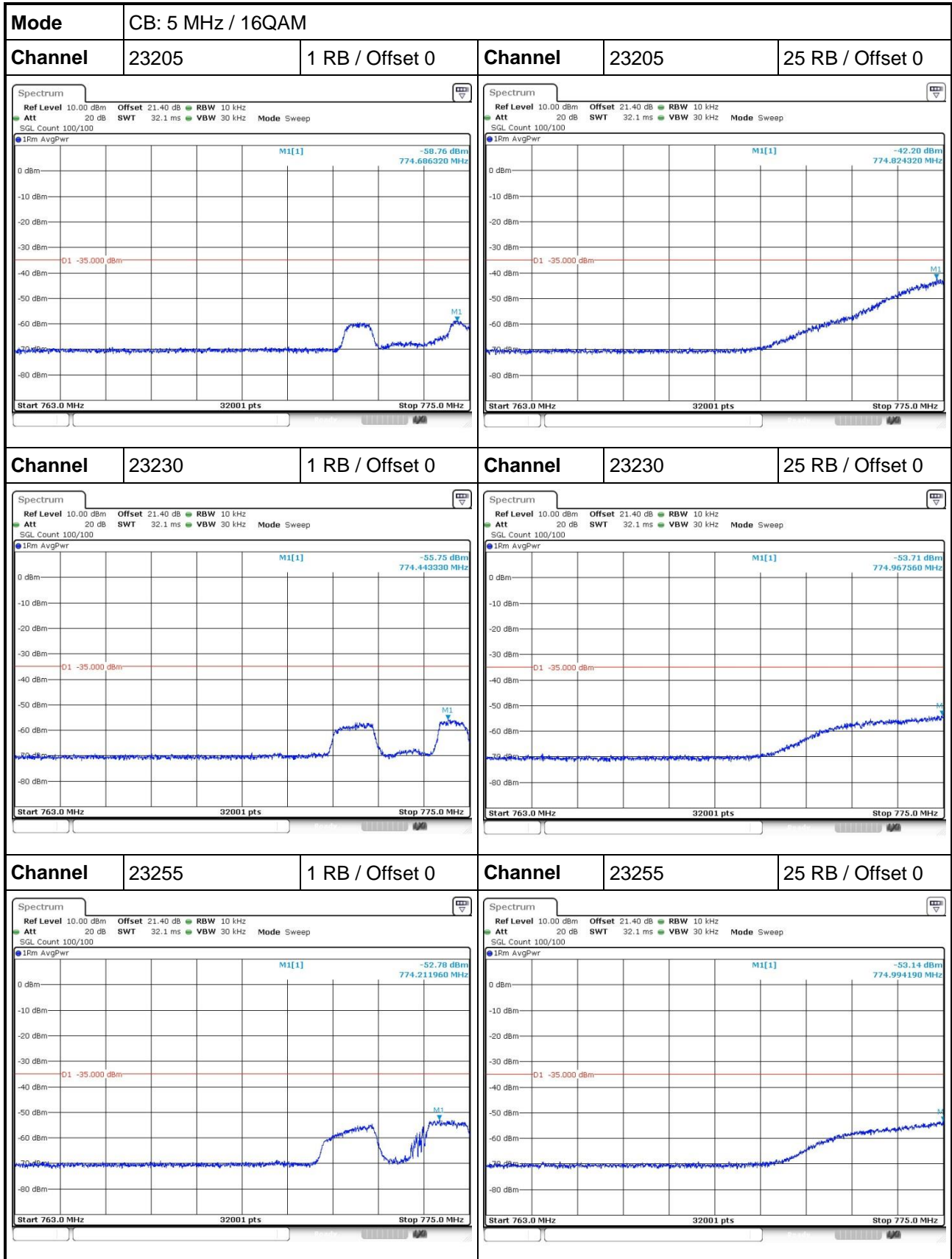

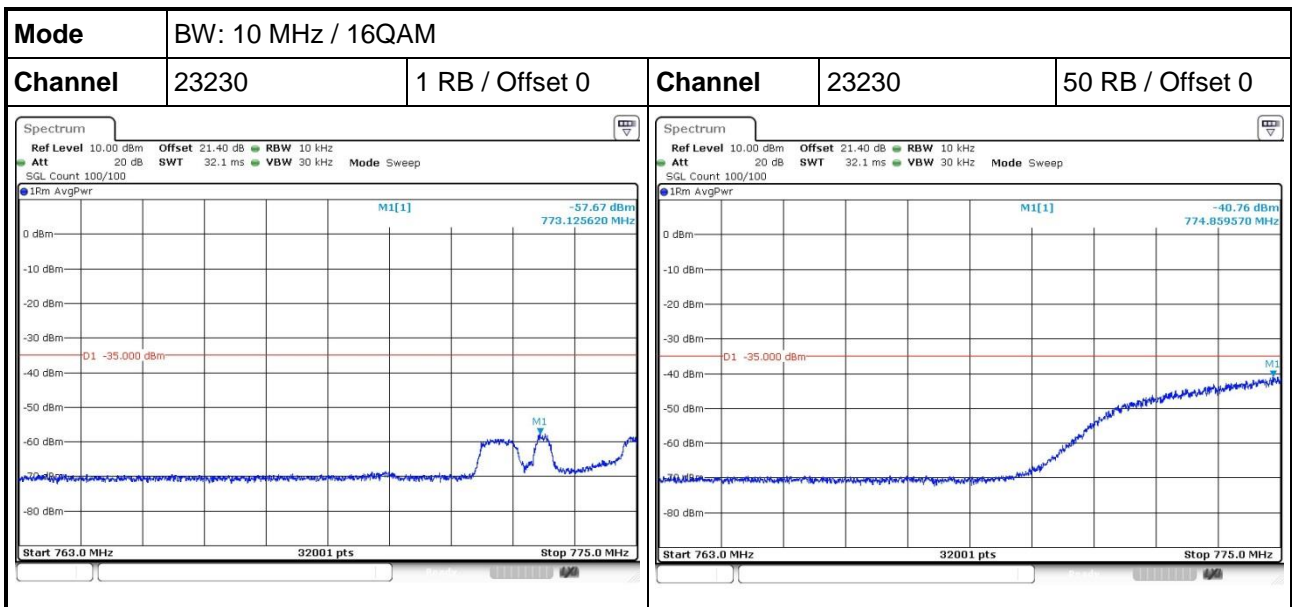
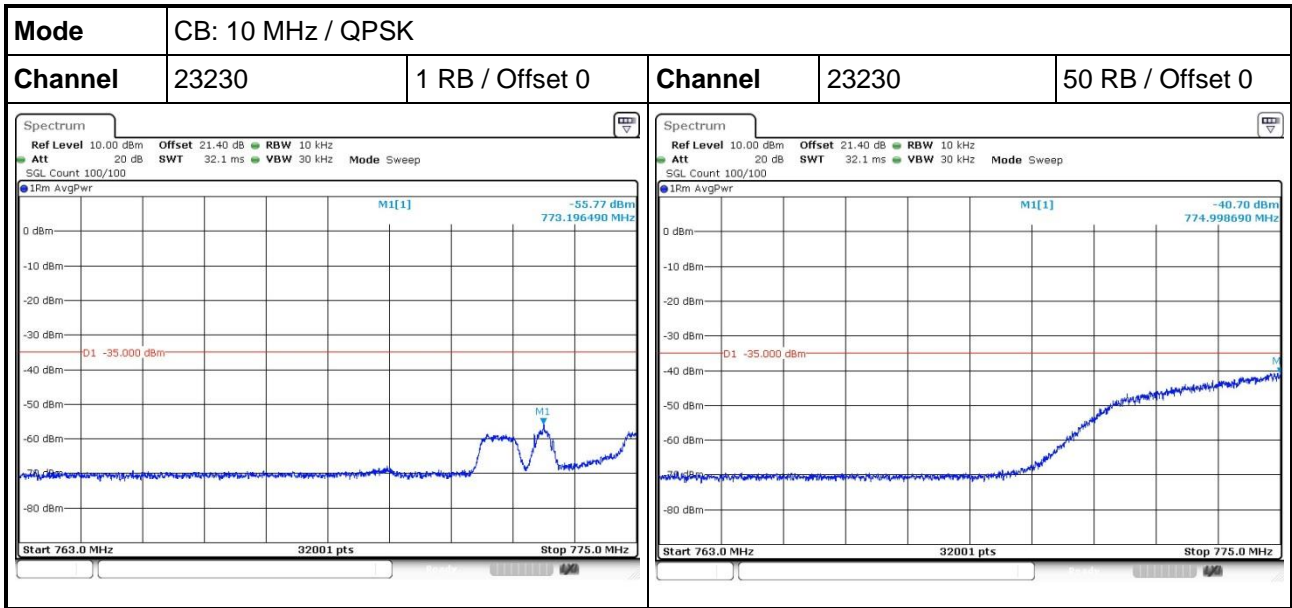

3.4.6 Test Result of 793~805 MHz

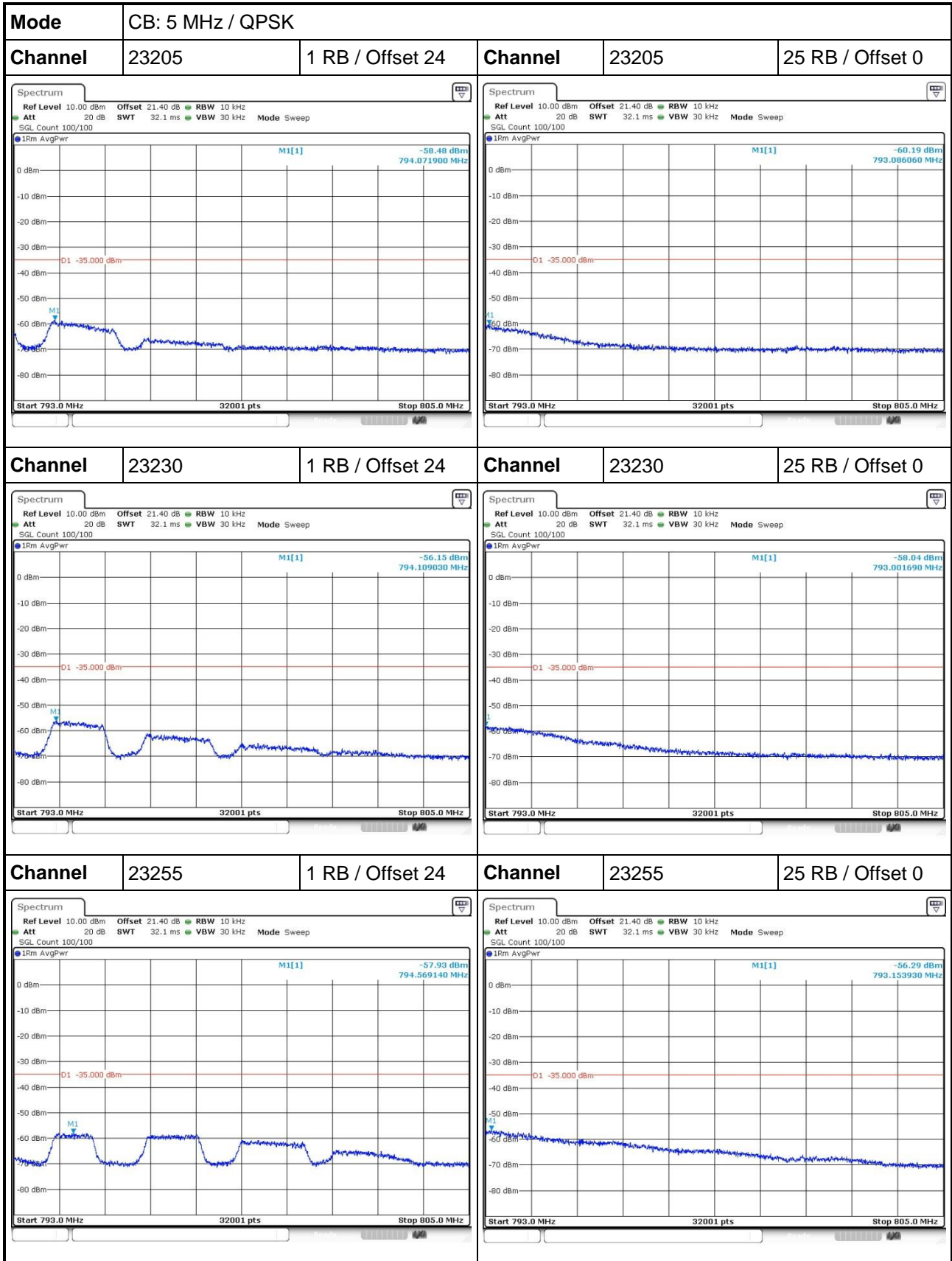

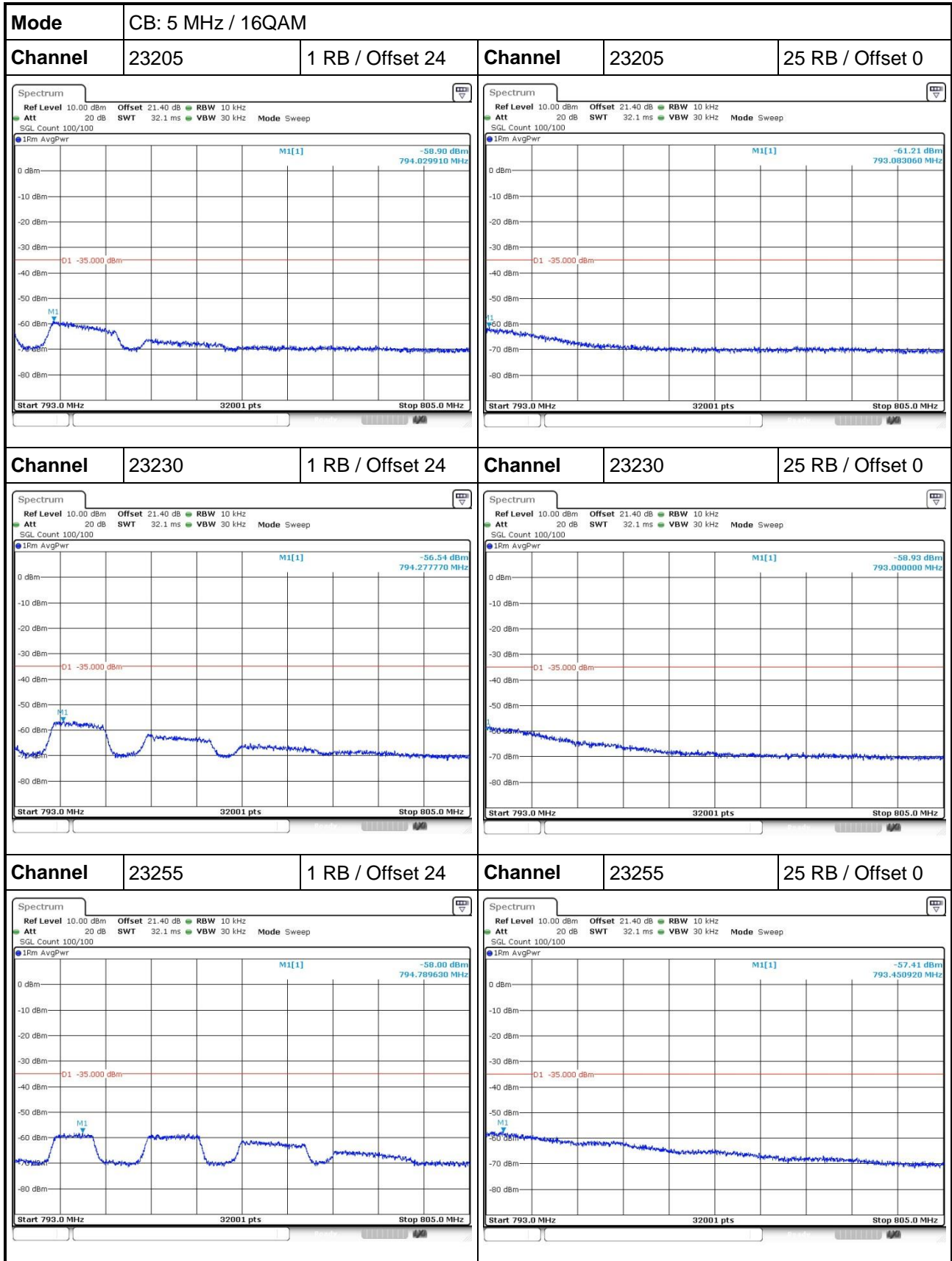

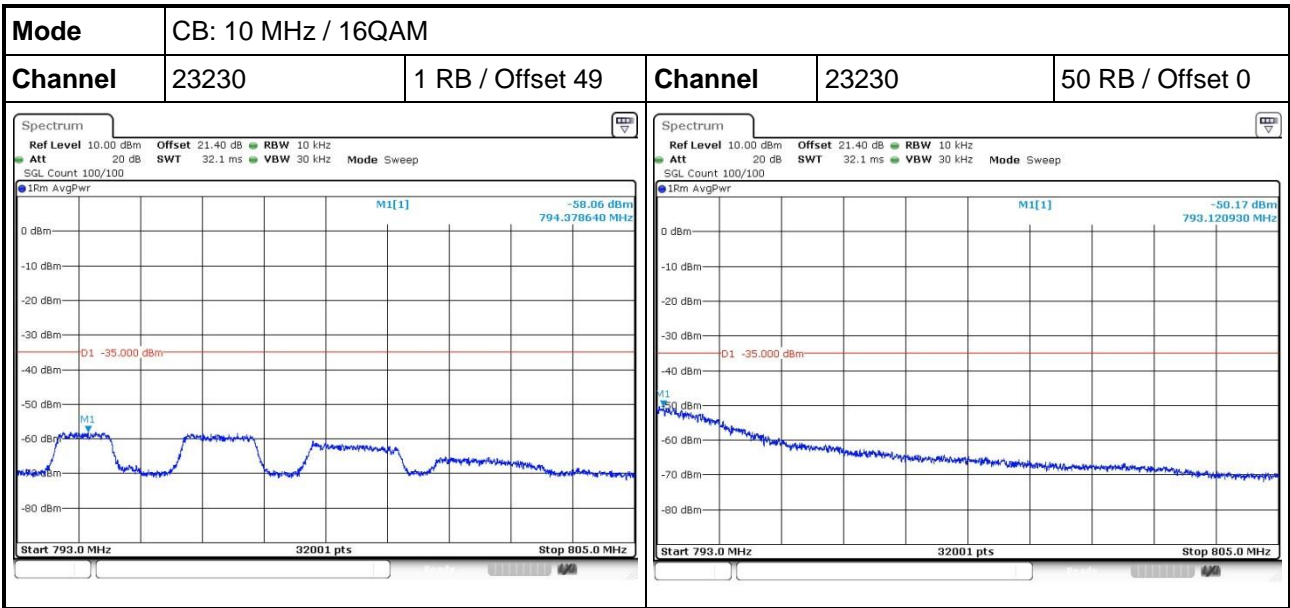
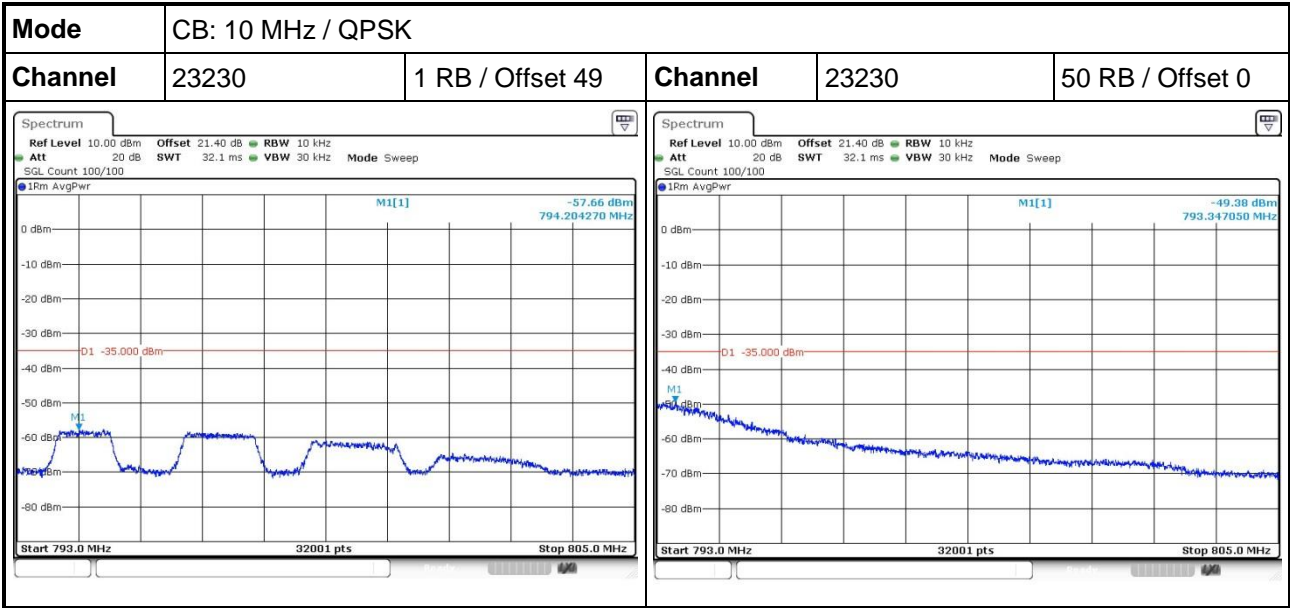

3.5 Occupied Bandwidth

3.5.1 Test Procedures

1. Set resolution bandwidth (RBW) = 100 kHz, Video bandwidth=300kHz.
2. Detector = Peak, Trace mode = max hold.
3. Sweep = auto couple, Allow the trace to stabilize.
4. Using occupied bandwidth measurement function of spectrum analyzer to measure occupied bandwidth.

3.5.2 Test Setup

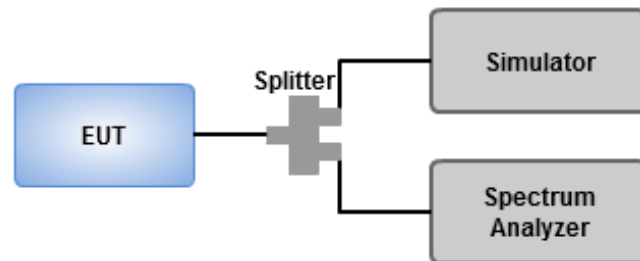

3.5.3 Test Result of Occupied Bandwidth

Channel Bandwidth (MHz)	Modulation	Channel	Frequency (MHz)	26dB BW (MHz)	99% OBW (MHz)
5	QPSK	23205	779.5	5.09	4.50
5	QPSK	23230	782.0	5.15	4.53
5	QPSK	23255	784.5	5.14	4.52
5	16QAM	23205	779.5	5.09	4.50
5	16QAM	23230	782.0	5.09	4.50
5	16QAM	23255	784.5	5.16	4.50



Channel Bandwidth (MHz)	Modulation	Channel	Frequency (MHz)	26dB BW (MHz)	99% OBW (MHz)
10	QPSK	23230	782.0	9.90	9.03
10	16QAM	23230	782.0	9.93	8.97



3.6 Frequency Stability

3.6.1 Limit of Frequency Stability

The frequency stability shall be sufficient to ensure that the fundamental emissions stay within the authorized bands of operation.

3.6.2 Test Procedures

1. EUT was placed at temperature chamber and connected to an external power supply.
2. Temperature and voltage condition shall be tested to confirm frequency stability.
3. Temperature range is from -30~50°C and voltage range is from lowest to highest working voltage.
4. Tem Link up EUT and simulator. Confirm frequency drift value of simulator and record it.

3.6.3 Test Setup

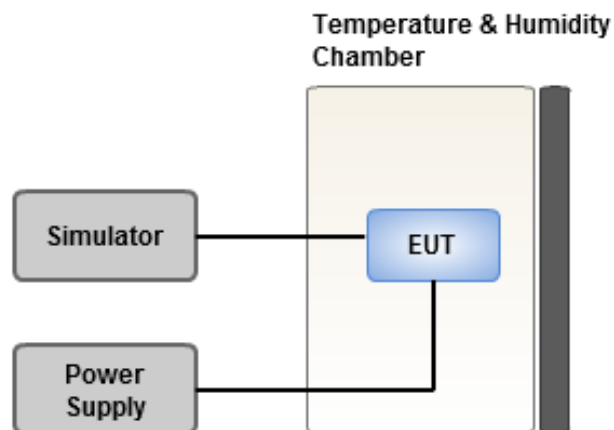

3.6.4 Test Result of Frequency Stability

CB: 5MHz			
Temperature (°C)	Voltage (Vac)	Frequency Drift (ppm)	Limit (ppm)
50	110	0.005	2.5
40	110	0.004	2.5
30	110	0.004	2.5
20	110	0.003	2.5
10	110	-0.001	2.5
0	110	-0.004	2.5
-10	110	-0.006	2.5
-20	110	-0.006	2.5
-30	110	-0.008	2.5
20	126.5	0.003	2.5
20	93.5	0.001	2.5

CB: 10MHz			
Temperature (°C)	Voltage (Vac)	Frequency Drift (ppm)	Limit (ppm)
50	110	0.005	2.5
40	110	0.003	2.5
30	110	0.001	2.5
20	110	-0.001	2.5
10	110	-0.003	2.5
0	110	-0.005	2.5
-10	110	-0.008	2.5
-20	110	-0.008	2.5
-30	110	-0.010	2.5
20	126.5	0.003	2.5
20	93.5	0.004	2.5

3.7 Peak to Average Ratio

3.7.1 Limit of Peak to Average Ratio

The Peak-to-average ratio (PAR) of the transmission may not exceed 13 dB.

3.7.2 Test Procedures

1. Set the number of counts to a value that stabilizes the measured CCDF curve.
2. Set the measurement interval to 1 ms.
3. Record the maximum PAPR level associated with a probability of 0.1%.

3.7.3 Test Setup

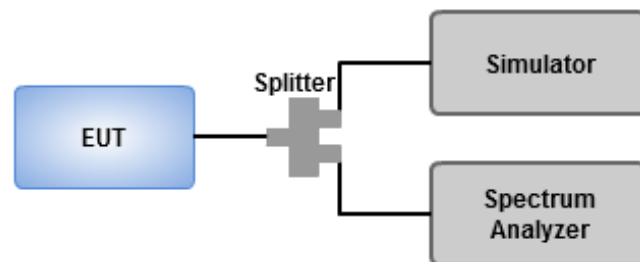

3.7.4 Test Result of Peak to Average Ratio

Channel Bandwidth (MHz)	Modulation	Channel	Frequency (MHz)	Peak to Average Ratio (dB)
5	QPSK	23205	779.5	6.00
5	QPSK	23230	782.0	6.29
5	QPSK	23255	784.5	6.00
5	16QAM	23205	779.5	6.84
5	16QAM	23230	782.0	6.84
5	16QAM	23255	784.5	6.61

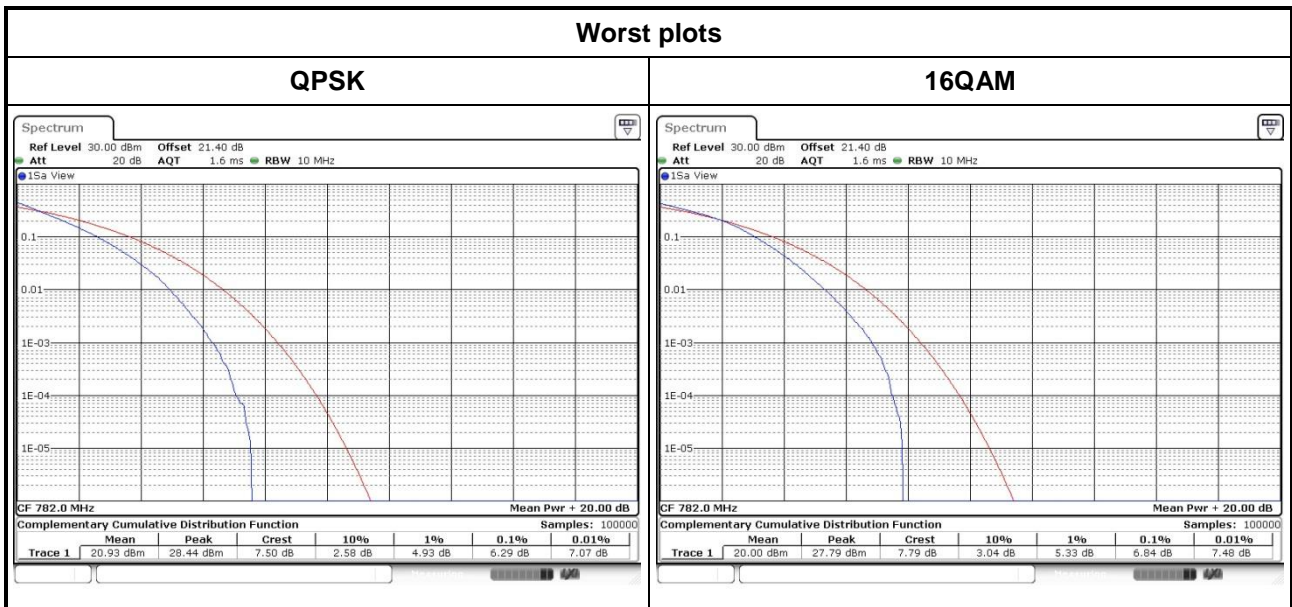

Channel Bandwidth (MHz)	Modulation	Channel	Frequency (MHz)	Peak to Average Ratio (dB)
10	QPSK	23230	782.0	5.74
10	16QAM	23230	782.0	6.61



4 Test laboratory information

Established in 2012, ICC provides foremost EMC & RF Testing and advisory consultation services by our skilled engineers and technicians. Our services employ a wide variety of advanced edge test equipment and one of the widest certification extents in the business.

International Certification Corp, it is our definitive objective is to institute long term, trust-based associations with our clients. The expectation we set up with our clients is based on outstanding service, practical expertise and devotion to a certified value structure. Our passion is to grant our clients with best EMC / RF services by oriented knowledgeable and accommodating staff.

Our Test sites are located at Linkou District and Kwei Shan Hsiang. Location map can be found on our website <http://www.icertifi.com.tw>.

Linkou

Tel: 886-2-2601-1640

No. 30-2, Ding Fwu Tsuen, Lin Kou District, New Taipei City, Taiwan, R.O.C.

Kwei Shan

Tel: 886-3-271-8666

No. 3-1, Lane 6, Wen San 3rd St., Kwei Shan Hsiang, Tao Yuan Hsien 333, Taiwan, R.O.C.

If you have any suggestion, please feel free to contact us as below information

Tel: 886-3-271-8666

Fax: 886-3-318-0155

Email: ICC_Service@icertifi.com.tw

==END==