



A D T

FCC TEST REPORT (PART 27)

REPORT NO.: RF990825C12

MODEL NO.: WIXS-168

(refer to item 3.1 for more details)

FCC ID: MXF-WIXS-168

RECEIVED: Aug. 25, 2010

TESTED: Jul. 04 ~ Jul. 06, 2011

ISSUED: Jul. 08, 2011

APPLICANT: Gemtek Technology Co., Ltd.

ADDRESS: No. 15-1, Zhonghua Rd, Hsinchu Industrial Park,
Hsinchu County, Taiwan, R.O.C. 303

ISSUED BY: Bureau Veritas Consumer Products Services (H.K.)
Ltd., Taoyuan Branch

LAB ADDRESS: No. 47, 14th Ling, Chia Pau Tsuen, Lin Kou Hsiang,
Taipei Hsien 244, Taiwan, R.O.C.

TEST LOCATION: No. 19, Hwa Ya 2nd Rd, Wen Hwa Tsuen, Kwei
Shan Hsiang, Taoyuan Hsien 333, Taiwan, R.O.C.

This test report consists of 67 pages in total. It may be duplicated completely for legal use with the approval of the applicant. It should not be reproduced except in full, without the written approval of our laboratory. The client should not use it to claim product certification, approval, or endorsement by TAF or any government agency. The test results in the report only apply to the tested sample.





TABLE OF CONTENTS

RELEASE CONTROL RECORD	4
1 CERTIFICATION.....	5
2 SUMMARY OF TEST RESULTS	6
2.1 MEASUREMENT UNCERTAINTY.....	6
3 GENERAL INFORMATION.....	7
3.1 GENERAL DESCRIPTION OF EUT	7
3.2 DESCRIPTION OF TEST MODES.....	9
3.2.1 CONFIGURATION OF SYSTEM UNDER TEST	9
3.2.2 TEST MODE APPLICABILITY AND TESTED CHANNEL DETAIL	10
3.3 GENERAL DESCRIPTION OF APPLIED STANDARDS	13
3.4 DESCRIPTION OF SUPPORT UNITS	14
4 TEST TYPES AND RESULTS	15
4.1 OUTPUT POWER MEASUREMENT	15
4.1.1 LIMITS OF OUTPUT POWER MEASUREMENT	15
4.1.2 TEST INSTRUMENTS.....	15
4.1.3 TEST PROCEDURES	16
4.1.4 TEST SETUP.....	16
4.1.5 EUT OPERATING CONDITIONS	16
4.1.6 TEST RESULTS	17
4.2 FREQUENCY STABILITY MEASUREMENT.....	20
4.2.1 LIMITS OF FREQUENCY STABILITY MEASUREMENT	20
4.2.2 TEST INSTRUMENTS.....	20
4.2.3 TEST PROCEDURE.....	21
4.2.4 TEST SETUP.....	21
4.2.5 EUT OPERATING CONDITIONS	21
4.2.6 TEST RESULTS	22
4.3 EMISSION BANDWIDTH MEASUREMENT	24
4.3.1 LIMITS OF EMISSION BANDWIDTH MEASUREMENT	24
4.3.2 TEST INSTRUMENTS.....	24
4.3.3 TEST PROCEDURE.....	24
4.3.4 TEST SETUP.....	25
4.3.5 EUT OPERATING CONDITIONS	25
4.3.6 TEST RESULTS	26
4.4 PEAK TO AVERAGE RATIO.....	28
4.4.1 LIMITS OF PEAK TO AVERAGE RATIO MEASUREMENT	28
4.4.2 TEST INSTRUMENTS.....	28
4.4.3 TEST PROCEDURES	28
4.4.4 TEST SETUP.....	28
4.4.5 EUT OPERATING CONDITION.....	28
4.4.6 TEST RESULTS	29
4.5 BAND EDGE MEASUREMENT.....	31
4.5.1 LIMITS OF BAND EDGE MEASUREMENT	31
4.5.2 TEST INSTRUMENTS.....	31
4.5.3 TEST SETUP.....	31



A D T

4.5.4	TEST PROCEDURES	32
4.5.5	EUT OPERATING CONDITION.....	32
4.5.6	TEST RESULTS	33
4.6	CONDUCTED SPURIOUS EMISSIONS	40
4.6.1	LIMITS OF CONDUCTED SPURIOUS EMISSIONS MEASUREMENT.....	40
4.6.2	TEST INSTRUMENTS.....	40
4.6.3	TEST PROCEDURE.....	41
4.6.4	TEST SETUP.....	41
4.6.5	EUT OPERATING CONDITIONS	41
4.6.6	TEST RESULTS	42
4.7	RADIATED EMISSION MEASUREMENT (BELOW 1GHz).....	48
4.7.1	LIMITS OF RADIATED EMISSION MEASUREMENT.....	48
4.7.2	TEST INSTRUMENTS.....	49
4.7.3	TEST PROCEDURES	50
4.7.4	DEVIATION FROM TEST STANDARD	50
4.7.5	TEST SETUP.....	51
4.7.6	EUT OPERATING CONDITIONS	51
4.7.7	TEST RESULTS	52
4.8	RADIATED EMISSION MEASUREMENT (ABOVE 1GHz)	60
4.8.1	LIMITS OF RADIATED EMISSION MEASUREMENT.....	60
4.8.2	TEST INSTRUMENTS.....	60
4.8.3	TEST PROCEDURES	61
4.8.4	DEVIATION FROM TEST STANDARD	61
4.8.5	TEST SETUP.....	62
4.8.6	EUT OPERATING CONDITIONS	62
4.8.7	TEST RESULTS	63
5	PHOTOGRAPHS OF THE TEST CONFIGURATION.....	66
6	INFORMATION ON THE TESTING LABORATORIES	67



A D T

RELEASE CONTROL RECORD

ISSUE NO.	REASON FOR CHANGE	DATE ISSUED
Original release	N/A	Jul. 08, 2011



A D T

1 CERTIFICATION

PRODUCT: WiMAX Outdoor CPE

MODEL: WIXS-168 (refer to item 3.1 for more details)

BRAND: Gemtek (refer to item 3.1 for more details)

APPLICANT: Gemtek Technology Co., Ltd.

TESTED: Jul. 04 ~ Jul. 06, 2011

TEST SAMPLE: ENGINEERING SAMPLE

TEST STANDARDS: FCC Part 27, Subpart C & D

The above equipment (Model: WIXS-168) has been tested by **Bureau Veritas Consumer Products Services (H.K.) Ltd., Taoyuan Branch**, and found compliance with the requirement of the above standards. The test record, data evaluation & Equipment Under Test (EUT) configurations represented herein are true and accurate accounts of the measurements of the sample's EMC characteristics under the conditions specified in this report.

PREPARED BY :  , DATE : Jul. 08, 2011
Rennie Wang / Supervisor

APPROVED BY :  , DATE : Jul. 08, 2011
Gary Chang / Assistant Manager



2 SUMMARY OF TEST RESULTS

The EUT has been tested according to the following specifications:

STANDARD SECTION	TEST TYPE AND LIMIT	RESULT	REMARK
FCC Part 27 & Part 2			
27.50(a)(2)	Maximum Peak Output Power Limit: max. 2 Watt.	PASS	Meet the requirement of limit. Minimum passing margin is 20.44dBm at 2357.5MHz.
2.1055 27.54	Frequency Stability Stay with the authorized bands of operation	PASS	Meet the requirement of limit.
27.53(a)(5)	Emission Bandwidth	PASS	Meet the requirement of limit.
27.50(d)(5)	Peak to Average Ratio	PASS	Meet the requirement of limit.
27.53(a)(2)	Band Edge Measurements	PASS	Meet the requirement of limit.
27.53(a)(2)	Conducted Spurious Emissions	PASS	Meet the requirement of limit.
27.53(a)(2)	Radiated Spurious Emissions	PASS	Meet the requirement of limit. Minimum passing margin is -1.2dB at 9230MHz & 9250MHz.

2.1 MEASUREMENT UNCERTAINTY

Where relevant, the following measurement uncertainty levels have been estimated for tests performed on the EUT as specified in CISPR 16-4-2:

MEASUREMENT	FREQUENCY	UNCERTAINTY
Conducted emissions	9kHz~30MHz	2.44 dB
Radiated emissions	30MHz ~ 200MHz	3.19 dB
	200MHz ~1000MHz	3.21 dB
	1GHz ~ 18GHz	2.26 dB
	18GHz ~ 40GHz	1.94 dB

This uncertainty represents an expanded uncertainty expressed at approximately the 95% confidence level using a coverage factor of k = 2.



A D T

3 GENERAL INFORMATION

3.1 GENERAL DESCRIPTION OF EUT

EUT	WiMAX Outdoor CPE	
MODEL NO.	WIXS-168 (refer to NOTE for more details)	
FCC ID	MXF-WIXS-168	
NOMINAL VOLTAGE	48Vdc	
CODED TYPE/MODULATION/ CODING RATE	UL	QPSK: 1/2, 3/4
		16QAM: 1/2, 3/4
	DL	QPSK: 1/2, 3/4
		16QAM: 1/2, 3/4
		64QAM: 1/2, 2/3, 3/4, 5/6
MODULATION TECHNOLOGY	OFDMA	
DUPLEX METHOD	TDD	
MULTIPLE ACCESS METHOD:	TDMA	
OPERATING RANGE	2305MHz ~ 2320MHz 2345MHz ~ 2360MHz	
CHANNEL BANDWIDTH	5MHz, 10MHz	
MAX. COUDUCTED POWER	20.44dBm	
MAX. EIRP OUTPUT POWER	33.64dBm	
ANTENNA TYPE	Patch antenna with 13.2dBi gain	
OPERATION TEMPERATURE RANGE	-40°C ~ 70°C	
DATA CABLE	1.7m shielded RJ45 cable with one core	
I/O PORTS	Refer to user's manual	
ACCESSORY DEVICES	POE	

NOTE:

1. All models are listed as below.

BRAND	MODEL	DESCRIPTION
Gemtek	WIXS-168	All models are electrically identical, different brands and model names are for marketing purpose.
Alvarion	4M-CPE3000-PRO-1D-2.3	



A D T

2. The EUT consumes power from the following PoEs.

POE 1	
BRAND	PowerDsine™ 3001
MODEL	PD-3001/AC
INPUT POWER	100-250Vac, 0.5A, 50/60Hz
OUTPUT POWER	48Vdc, 0.35A

POE 2	
BRAND	PHIHONG
MODEL	POE16U-480
INPUT POWER	100-240Vac, 0.4A, 50-60Hz
OUTPUT POWER	48Vdc, 0.32A

3. The EUT can supports different UL / DL ratio, max transmit ratio is up to 16 (UL): 31 (DL). After pretesting of output power and spurious emission, 16 (UL): 31 (DL) was found to be worst case and was selected for the final test configuration.
4. For the EUT with modulation type and coding rate, after pre-testing in test items of output power and spurious emissions, QPSK 1/2 was found to be worst case and was selected for the final test configuration.
5. The above EUT information is declared by manufacturer and for more detailed feature description please refers to the manufacturer's specifications or User's Manual.

3.2 DESCRIPTION OF TEST MODES

The following channels had been tested for each channel bandwidth.

	CHANNEL BANDWIDTH 5.0 MHz		CHANNEL BANDWIDTH 10.0 MHz	
CHANNEL FREQUENCY RANGE	2305 ~ 2320MHz	2345 ~ 2360MHz	2305 ~ 2320MHz	2345 ~ 2360MHz
CHANNEL FREQUENCY (MHz)	2307.5 MHz	2352.5 MHz	2310 MHz	2355 MHz
	2312.5 MHz	2357.5 MHz	-	-

3.2.1 CONFIGURATION OF SYSTEM UNDER TEST

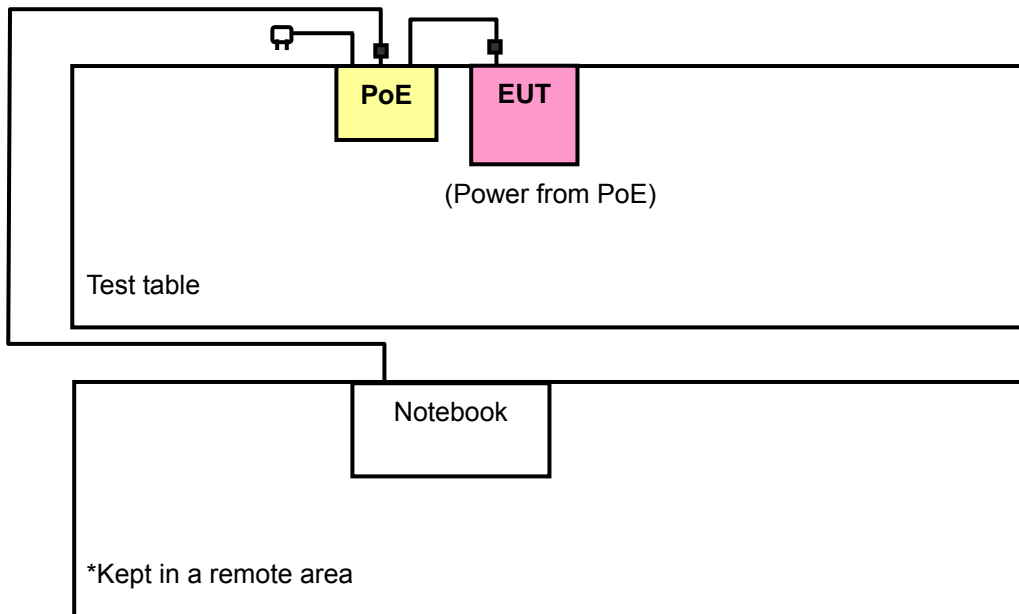

NOTE: The antenna port of EUT connected with a terminator.



3.2.2 TEST MODE APPLICABILITY AND TESTED CHANNEL DETAIL

EUT CONFIGURE MODE	APPLICABLE TO								DESCRIPTION
	OP	FS	EB	PA	BE	CSE	RE<1G	RE≥1G	
A	√	√	√	√	√	√	√	√	POE1: PD-3001/AC
B	-	-	-	-	-	-	√	-	POE2: POE16U-480

Where **OP**: Output power **FS**: Frequency stability
EB: Emission bandwidth **PA**: Peak to Average Ratio
BE: Band edge **CSE**: Conducted spurious emissions
RE<1G: Radiated emission below 1GHz **RE≥1G**: Radiated emission above 1GHz

NOTE: "-" means no effect.

OUTPUT POWER MEASUREMENT:

- Pre-Scan has been conducted to determine the worst-case mode from all possible combinations between available modulations, coding rate, and antenna ports (if EUT with antenna diversity architecture).
- Following channel(s) was (were) selected for the final test as listed below.

EUT CONFIGURE MODE	TESTED CHANNEL (MHz)	MODULATION TECHNOLOGY	CHANNEL BANDWIDTH	MODULATION TYPE	CODING RATE
A	2307.5, 2312.5, 2352.5, 2357.5	OFDMA	5.0MHz	QPSK	1/2
A	2310, 2355	OFDMA	10.0MHz	QPSK	1/2

FREQUENCY STABILITY MEASUREMENT:

- Pre-Scan has been conducted to determine the worst-case mode from all possible combinations between available modulations, coding rate, and antenna ports (if EUT with antenna diversity architecture).
- Following channel(s) was (were) selected for the final test as listed below.

EUT CONFIGURE MODE	TESTED CHANNEL (MHz)	MODULATION TECHNOLOGY	CHANNEL BANDWIDTH	MODULATION TYPE	CODING RATE
A	2357.5	OFDMA	5.0MHz	QPSK	1/2
A	2355	OFDMA	10.0MHz	QPSK	1/2



EMISSION BANDWIDTH MEASUREMENT:

- Pre-Scan has been conducted to determine the worst-case mode from all possible combinations between available modulations, coding rate, and antenna ports (if EUT with antenna diversity architecture).
- Following channel(s) was (were) selected for the final test as listed below.

EUT CONFIGURE MODE	TESTED CHANNEL (MHz)	MODULATION TECHNOLOGY	CHANNEL BANDWIDTH	MODULATION TYPE	CODING RATE
A	2307.5, 2312.5, 2352.5, 2357.5	OFDMA	5.0MHz	QPSK	1/2
A	2310, 2355	OFDMA	10.0MHz	QPSK	1/2

PEAK TO AVERAGE RATIO:

- Pre-Scan has been conducted to determine the worst-case mode from all possible combinations between available modulations, coding rate, and antenna ports (if EUT with antenna diversity architecture).
- Following channel(s) was (were) selected for the final test as listed below.

EUT CONFIGURE MODE	TESTED CHANNEL (MHz)	MODULATION TECHNOLOGY	CHANNEL BANDWIDTH	MODULATION TYPE	CODING RATE
A	2307.5, 2312.5, 2352.5, 2357.5	OFDMA	5.0MHz	QPSK	1/2
A	2310, 2355	OFDMA	10.0MHz	QPSK	1/2

BAND EDGE MEASUREMENT:

- Pre-Scan has been conducted to determine the worst-case mode from all possible combinations between available modulations, coding rate, and antenna ports (if EUT with antenna diversity architecture).
- Following channel(s) was (were) selected for the final test as listed below.

EUT CONFIGURE MODE	TESTED CHANNEL (MHz)	MODULATION TECHNOLOGY	CHANNEL BANDWIDTH	MODULATION TYPE	CODING RATE
A	2307.5, 2312.5, 2352.5, 2357.5	OFDMA	5.0MHz	QPSK	1/2
A	2310, 2355	OFDMA	10.0MHz	QPSK	1/2



CONDUCTED SPURIOUS EMISSIONS MEASUREMENT:

- Pre-Scan has been conducted to determine the worst-case mode from all possible combinations between available modulations, coding rate, and antenna ports (if EUT with antenna diversity architecture).
- Following channel(s) was (were) selected for the final test as listed below.

EUT CONFIGURE MODE	TESTED CHANNEL (MHz)	MODULATION TECHNOLOGY	CHANNEL BANDWIDTH	MODULATION TYPE	CODING RATE
A	2307.5, 2312.5, 2352.5, 2357.5	OFDMA	5.0MHz	QPSK	1/2
A	2310, 2355	OFDMA	10.0MHz	QPSK	1/2

RADIATED EMISSION MEASUREMENT (BELOW 1 GHz):

- Pre-Scan has been conducted to determine the worst-case mode from all possible combinations between available modulations, coding rate, and antenna ports (if EUT with antenna diversity architecture).
- Following channel(s) was (were) selected for the final test as listed below.

EUT CONFIGURE MODE	TESTED CHANNEL (MHz)	MODULATION TECHNOLOGY	CHANNEL BANDWIDTH	MODULATION TYPE	CODING RATE
A, B	2312.5, 2357.5	OFDMA	5.0MHz	QPSK	1/2
A, B	2310, 2355	OFDMA	10.0MHz	QPSK	1/2

RADIATED EMISSION MEASUREMENT (ABOVE 1 GHz):

- Pre-Scan has been conducted to determine the worst-case mode from all possible combinations between available modulations, coding rate, and antenna ports (if EUT with antenna diversity architecture).
- Following channel(s) was (were) selected for the final test as listed below.

EUT CONFIGURE MODE	TESTED CHANNEL (MHz)	MODULATION TECHNOLOGY	CHANNEL BANDWIDTH	MODULATION TYPE	CODING RATE
A	2307.5, 2312.5, 2352.5, 2357.5	OFDMA	5.0MHz	QPSK	1/2
A	2310, 2355	OFDMA	10.0MHz	QPSK	1/2



A D T

TEST CONDITION:

APPLICABLE TO	ENVIRONMENTAL CONDITIONS	INPUT POWER	TESTED BY
OP	27deg. C, 67%RH, 1009 hPa	120Vac, 60Hz	Long Chen
FS	27deg. C, 67%RH, 1009 hPa	120Vac, 60Hz	Long Chen
EB	27deg. C, 67%RH, 1009 hPa	120Vac, 60Hz	Long Chen
PA	27deg. C, 67%RH, 1009 hPa	120Vac, 60Hz	Long Chen
BE	27deg. C, 67%RH, 1009 hPa	120Vac, 60Hz	Long Chen
CSE	27deg. C, 67%RH, 1009 hPa	120Vac, 60Hz	Long Chen
RE≥1G	26deg. C, 65%RH, 1011 hPa	120Vac, 60Hz	Sun Lin
RE<1G	26deg. C, 65%RH, 1011 hPa	120Vac, 60Hz	Sun Lin

3.3 GENERAL DESCRIPTION OF APPLIED STANDARDS

The EUT is a WiMAX product. According to the specifications of the manufacturer, it must comply with the requirements of the following standards:

FCC 47 CFR Part 2

FCC 47 CFR Part 27

ANSI/TIA/EIA-603-C-2004

NOTE: The EUT is also considered as a kind of computer peripheral, because the connection to computer is necessary for typical use. It has been verified to comply with the requirements of FCC Part 15, Subpart B, Class B (DoC). The test report has been issued separately.



A D T

3.4 DESCRIPTION OF SUPPORT UNITS

The EUT has been tested as an independent unit together with other necessary accessories or support units. The following support units or accessories were used to form a representative test configuration during the tests.

NO.	PRODUCT	BRAND	MODEL NO.	SERIAL NO.	FCC ID
1	NOTEBOOK	HP	NC6000	CNU4110Y6Q	E2K24CLNS

NO.	SIGNAL CABLE DESCRIPTION OF THE ABOVE SUPPORT UNITS
1	10 m shielded RJ45 cable

NOTE:

1. All power cords of the above support units are non shielded (1.8m).
2. Item 1 acted as a communication partner to transfer data.



A D T

4 TEST TYPES AND RESULTS

4.1 OUTPUT POWER MEASUREMENT

4.1.1 LIMITS OF OUTPUT POWER MEASUREMENT

For fixed customer premises equipment (CPE) stations transmitting in the 2305–2320 MHz band or in the 2345–2360 MHz band, the peak EIRP must not exceed 20 watts within any 5 megahertz of authorized bandwidth. For WCS CPE using TDD technology, the duty cycle must not exceed 38 percent.

4.1.2 TEST INSTRUMENTS

DESCRIPTION & MANUFACTURER	MODEL NO.	SERIAL NO.	DATE OF CALIBRATION	DUE DATE OF CALIBRATION
Spectrum Analyzer Agilent	E4446A	MY48250266	Aug. 11, 2010	Aug. 10, 2011

NOTE:

1. The calibration interval of the above test instruments is 12 months and the calibrations are traceable to NML/ROC and NIST/USA.
2. Measurement Bandwidth of ML2495A is 65MHz greater than 26dB bandwidth of emission.

4.1.3 TEST PROCEDURES

OUTPUT POWER

1. Connect the DUT transmitter output to the spectrum analyzer via coaxial cable while ensuring proper impedance matching.
2. Tune the analyzer to the nominal center frequency of the emission bandwidth (EBW).
3. Set the span to twice the nominal EBW (span = 2 x EBW).
4. Set the resolution bandwidth (RBW) to approximately 1% of EBW.
5. Set the video bandwidth (VBW) to 3 x RBW.
6. Select the average power (RMS) display detector.
7. Set the number of measurement points to ≥ 601 .
8. Use auto-coupled sweep time.
9. Perform measurement over an interval of time when the transmission is continuous and at its maximum power level.
10. Use the Band/Channel Power function to determine the integrated power over the full EBW.
11. Record the band power level.
12. Adjust the recorded level by applying appropriate correction factors for the measurement set-up.
13. Determine the EIRP by adding the effective antenna gain to the adjusted power level.

4.1.4 TEST SETUP

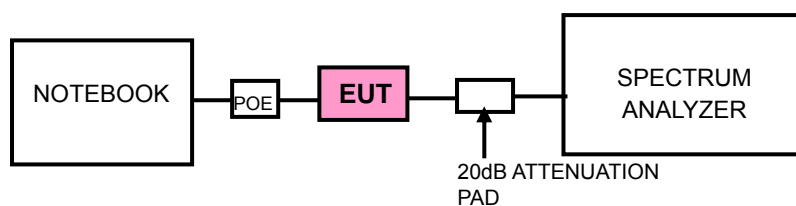

4.1.5 EUT OPERATING CONDITIONS

Executes telnet program to send commands via RJ45 cable to control EUT to transmit at specific modulation, coding rate, frequency and output power level.



4.1.6 TEST RESULTS

CONDUCTED POWER

CHANNEL BANDWIDTH: 5MHz				
CHANNEL FREQUENCY (MHz)	RAW VALUE (dBm)	CORRECTION FACTOR (dB)	OUTPUT POWER	
			dBm	mW
2307.5	-0.95	21.0	20.05	101.2
2312.5	-0.89	21.0	20.11	102.6
2352.5	-0.66	21.0	20.34	108.1
2357.5	-0.56	21.0	20.44	110.7

REMARKS: 1. Output Power (dBm) = Raw Value (dBm) + Correction Factor (dB).
2. Correction Factor (dB) = Cable Loss (dB) + 20dB Attenuator.

EIRP

CHANNEL BANDWIDTH: 5MHz				
CHANNEL FREQUENCY (MHz)	AVERAGE OUTPUT POWER (dBm)	MAX ANTENNA GAIN (dBi)	EIRP (dBm)	EIRP (mW)
2307.5	20.05	13.2	33.25	2113.5
2312.5	20.11	13.2	33.31	2142.9
2352.5	20.34	13.2	33.54	2259.4
2357.5	20.44	13.2	33.64	2312.1



A D T

CONDUCTED POWER

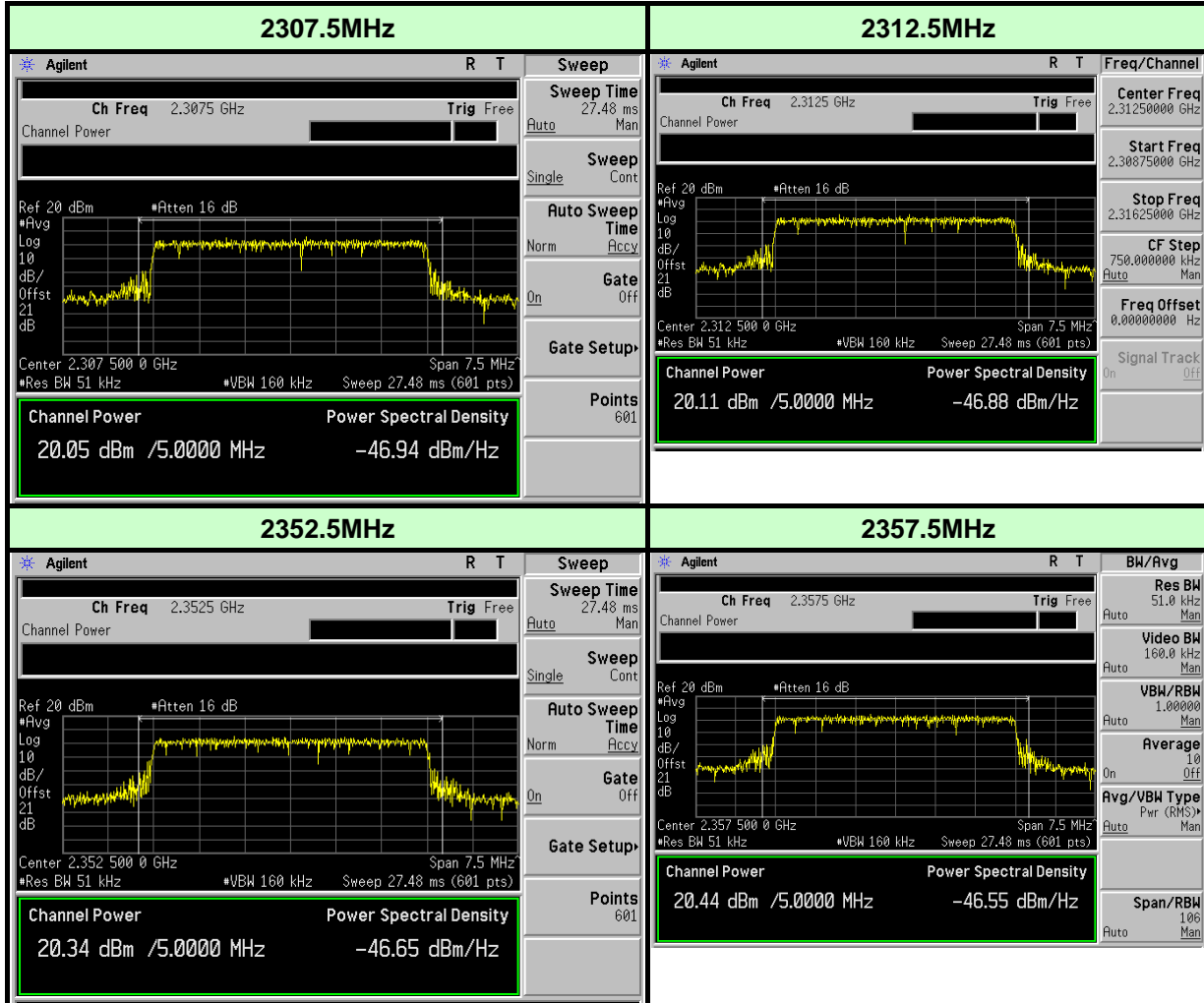



A D T

CONDUCTED POWER

CHANNEL BANDWIDTH: 10MHz				
CHANNEL FREQUENCY (MHz)	RAW VALUE (dBm)	CORRECTION FACTOR (dB)	OUTPUT POWER	
			dBm	mW
2310	-7.85	21.0	13.15	20.654
2355	-7.44	21.0	13.56	22.699

REMARKS: 1. Output Power (dBm) = Raw Value (dBm) + Correction Factor (dB).
 2. Correction Factor (dB) = Cable Loss (dB) + 20dB Attenuator.

EIRP

CHANNEL BANDWIDTH: 10MHz				
CHANNEL FREQUENCY (MHz)	AVERAGE OUTPUT POWER (dBm)	MAX ANTENNA GAIN (dBi)	EIRP (dBm)	EIRP (mW)
2310	13.15	13.2	26.35	431.519
2355	13.56	13.2	26.76	474.242

CONDUCTED POWER

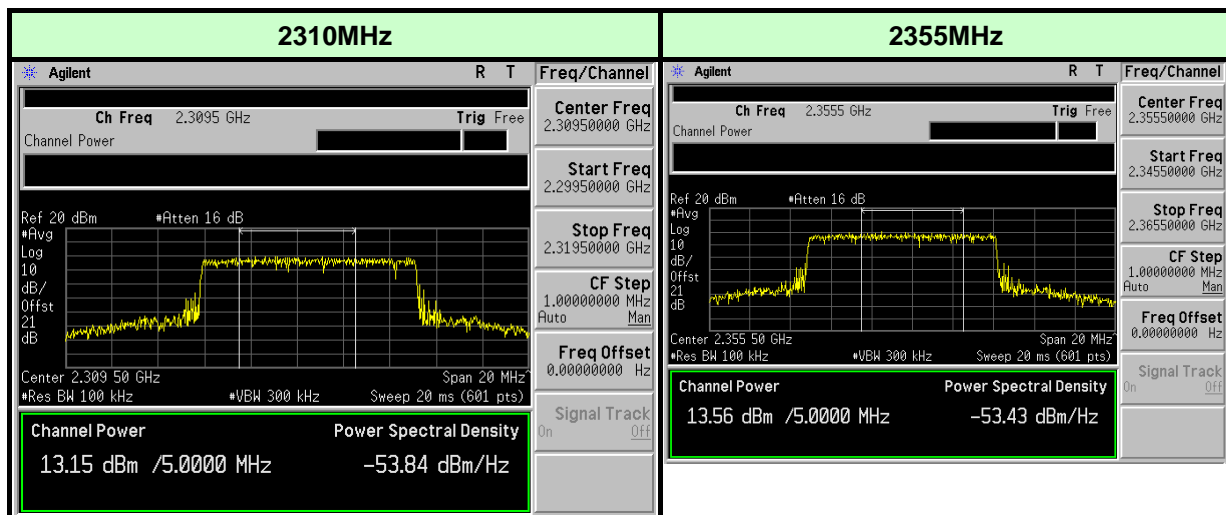

4.2 FREQUENCY STABILITY MEASUREMENT

4.2.1 LIMITS OF FREQUENCY STABILITY MEASUREMENT

According to the FCC part 27.54 shall be tested the frequency stability. The rule is defined that” The frequency stability shall be sufficient to ensure that the fundamental emissions stay within the authorized bands of operation.” The test extreme voltage is according to the 2.1055(d)(1) Vary primary supply voltage from 85 to 115 percent of the nominal value for other than hand carried battery equipment and the extreme temperature rule is comply with specification of EUT $-40^{\circ}\text{C} \sim 70^{\circ}\text{C}$.

4.2.2 TEST INSTRUMENTS

DESCRIPTION & MANUFACTURER	MODEL NO.	SERIAL NO.	DATE OF CALIBRATION	DUE DATE OF CALIBRATION
Spectrum Analyzer Agilent	E4446A	MY44360124	Dec. 29, 2010	Dec. 28, 2011
RF cable	SUCOFLEX 104	274403/4	Aug. 20, 2010	Aug. 19, 2011
WIT Standard Temperature & Humidity Chamber	TH-4S-C	W981030	Jun. 15, 2011	Jun. 14, 2012

NOTE: The calibration interval of the above test instruments is 12 months. And the calibrations are traceable to NML/ROC and NIST/USA.

4.2.3 TEST PROCEDURE

- a. Power must be removed when changing from one temperature to another or one voltage to another voltage. Power warm up is at least 15 min and power applied should perform before recording frequency error.
- b. EUT is connected the external power supply to control the AC input power. The various Volts from the minimum 93.5 Volts to 126.5 Volts. Each step shall be record the frequency error rate.
- c. The temperature range step is 10 degrees in this test items. All temperature levels shall be hold the $\pm 0.5^{\circ}\text{C}$ during the measurement testing.
- d. The each temperature step shall be at least 0.5 hours, consider the EUT could be test under the stability condition.

4.2.4 TEST SETUP

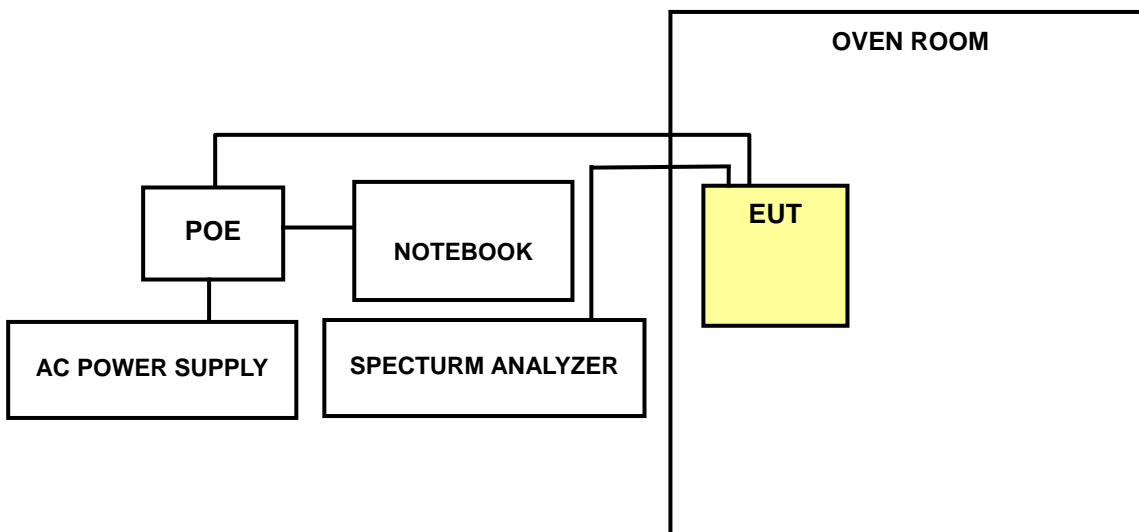

4.2.5 EUT OPERATING CONDITIONS

Same as 4.1.5



A D T

4.2.6 TEST RESULTS

CHANNEL BANDWIDTH: 5MHz			
AFC FREQUENCY ERROR VS. VOLTAGE			
VOLTAGE (Volts)	TEMP. (°C)	FREQUENCY (MHz)	FREQUENCY ERROR (ppm)
93.5	20	2357.500311	0.132
110.0	20	2357.500359	0.152
126.5	20	2357.500303	0.129

AFC FREQUENCY ERROR VS. TEMP.			
VOLTAGE (Volts)	TEMP. (°C)	FREQUENCY (MHz)	FREQUENCY ERROR (ppm)
110.0	70	2357.500985	0.418
110.0	60	2357.501336	0.567
110.0	50	2357.500283	0.120
110.0	40	2357.500889	0.377
110.0	30	2357.500827	0.351
110.0	20	2357.500359	0.152
110.0	10	2357.501172	0.497
110.0	0	2357.500348	0.148
110.0	-10	2357.501160	0.492
110.0	-20	2357.500496	0.210
110.0	-30	2357.500703	0.298
110.0	-40	2357.500774	0.328

CARRIER FREQUENCY: 2357.5MHz



A D T

CHANNEL BANDWIDTH: 10MHz			
AFC FREQUENCY ERROR VS. VOLTAGE			
VOLTAGE (Volts)	TEMP. (°C)	FREQUENCY (MHz)	FREQUENCY ERROR (ppm)
93.5	20	2355.000609	0.259
110.0	20	2355.000588	0.250
126.5	20	2355.000574	0.244

AFC FREQUENCY ERROR VS. TEMP.			
VOLTAGE (Volts)	TEMP. (°C)	FREQUENCY (MHz)	FREQUENCY ERROR (ppm)
110.0	70	2355.001575	0.669
110.0	60	2355.001373	0.583
110.0	50	2355.000142	0.060
110.0	40	2355.000946	0.402
110.0	30	2355.000900	0.382
110.0	20	2355.000588	0.250
110.0	10	2355.000562	0.239
110.0	0	2355.000775	0.329
110.0	-10	2355.001934	0.821
110.0	-20	2355.001446	0.614
110.0	-30	2355.001053	0.447
110.0	-40	2355.000621	0.264

CARRIER FREQUENCY: 2355MHz



A D T

4.3 EMISSION BANDWIDTH MEASUREMENT

4.3.1 LIMITS OF EMISSION BANDWIDTH MEASUREMENT

According to FCC 27.53(a)(5) specified that emission bandwidth is defined as the width of the signal between two points, one below the carrier center frequency and one above the carrier center frequency, outside of which all emissions are attenuated at least 26dB below the transmitter power.

4.3.2 TEST INSTRUMENTS

DESCRIPTION & MANUFACTURER	MODEL NO.	SERIAL NO.	DATE OF CALIBRATION	DUE DATE OF CALIBRATION
Spectrum Analyzer Agilent	E4446A	MY44360124	Dec. 29, 2010	Dec. 28, 2011
RF cable	SUCOFLEX 104	274403/4	Aug. 20, 2010	Aug. 19, 2011
DC-6GHz 20dB 50W Fixed attenuator Woken	MDC9331N-20	0724	May 13, 2011	May 12, 2012

NOTE: The calibration interval of the above test instruments is 12 months and the calibrations are traceable to NML/ROC and NIST/USA.

4.3.3 TEST PROCEDURE

The transmitter output was connected to the spectrum analyzer through an attenuator. The bandwidth of the fundamental frequency was measured by spectrum analyzer with RBW = 100kHz, VBW = 300kHz (for 5MHz channel bandwidth) and RBW = 200kHz, VBW = 620kHz (for 10MHz channel bandwidth). The 26dB bandwidth is defined as the total spectrum the power of which is higher than peak power minus 26dB.

4.3.4 TEST SETUP

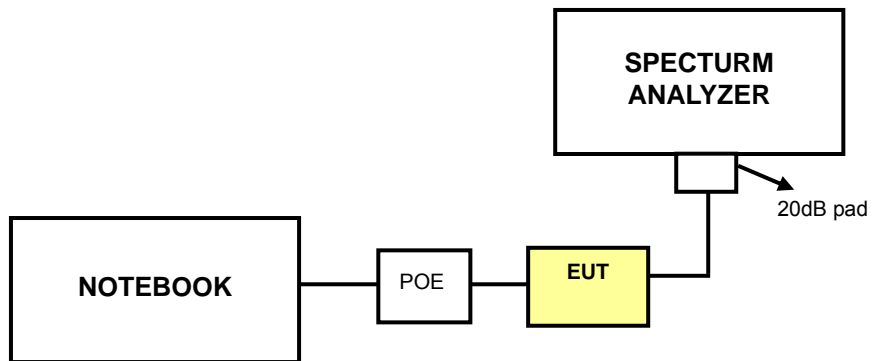

4.3.5 EUT OPERATING CONDITIONS

Same as 4.1.5



A D T

4.3.6 TEST RESULTS

CHANNEL BANDWIDTH: 5MHz	
CHANNEL FREQUENCY (MHz)	OCCUPIED BANDWIDTH (MHz)
2307.5	4.4390
2312.5	4.4387
2352.5	4.4440
2357.5	4.4501

THE SPECTRUM PLOT OF WORST VALUE OF EACH FREQUENCY BAND:

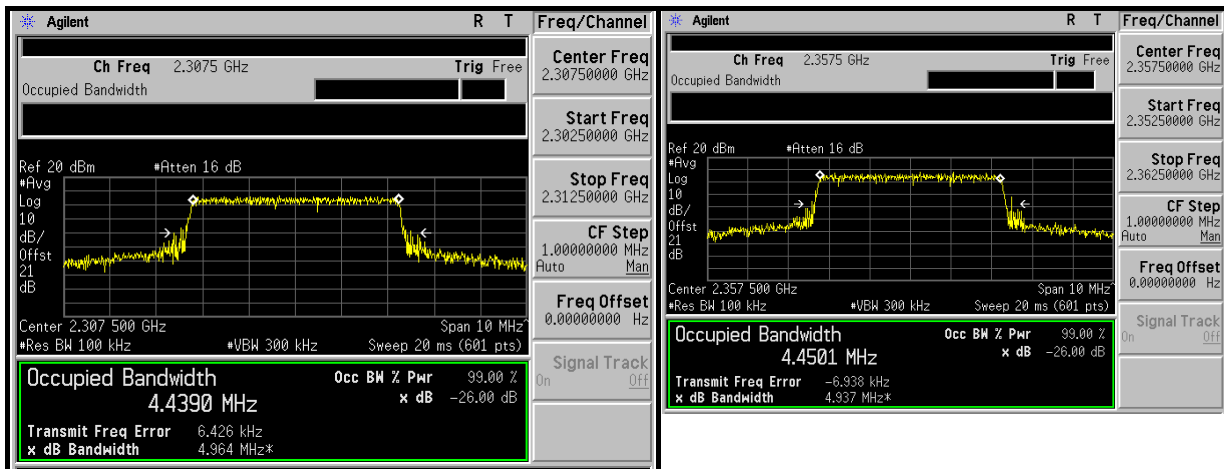



A D T

CHANNEL BANDWIDTH: 10MHz	
CHANNEL FREQUENCY (MHz)	OCCUPIED BANDWIDTH (MHz)
2310	9.1335
2355	9.1346

THE SPECTRUM PLOT OF WORST VALUE:

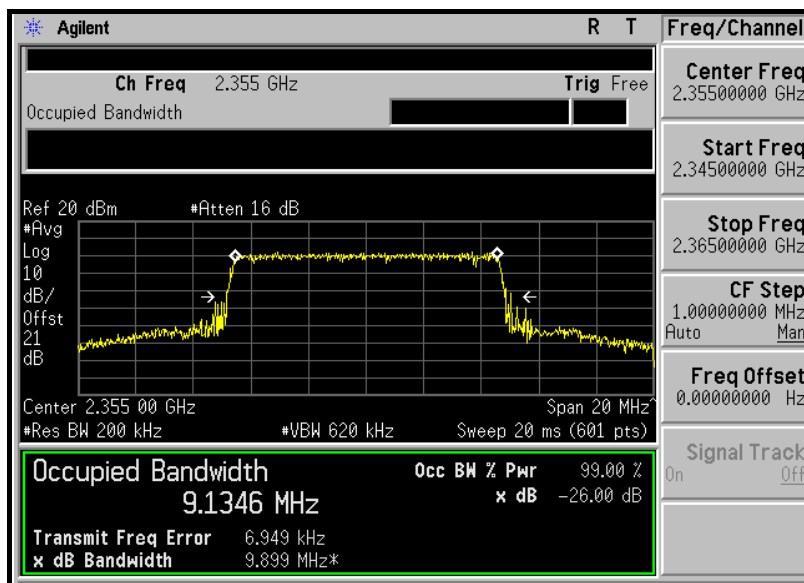



4.4 PEAK TO AVERAGE RATIO

4.4.1 LIMITS OF PEAK TO AVERAGE RATIO MEASUREMENT

In measuring transmissions in this band using an average power technique, the peak to-average ratio (PAR) of the transmission may not exceed 13 dB.

4.4.2 TEST INSTRUMENTS

DESCRIPTION & MANUFACTURER	MODEL NO.	SERIAL NO.	DATE OF CALIBRATION	DUE DATE OF CALIBRATION
JFW 20dB attenuation	50HF-020-SMA	NA	NA	NA
Suhner RF cable	SUCOFLEX 104	274403/4	Aug. 20, 2010	Aug. 19, 2011
R&S Spectrum Analyzer	FSU43	100115	Aug. 02, 2010	Aug. 01, 2011

NOTE: The calibration interval of the above test instruments is 12 months and the calibrations are traceable to NML/ROC and NIST/USA.

4.4.3 TEST PROCEDURES

1. Set resolution/measurement bandwidth \geq signal's occupied bandwidth;
2. Set the number of counts to a value that stabilizes the measured CCDF curve;
3. Record the maximum PAPR level associated with a probability of 0.1%.

4.4.4 TEST SETUP

Same as Item 4.2.4 (Conducted Power Setup)

4.4.5 EUT OPERATING CONDITION

Same as Item 4.1.5

4.4.6 TEST RESULTS

CHANNEL BANDWIDTH: 5MHz	
CHANNEL FREQUENCY (MHz)	PEAK TO AVERAGE RATIO (dB)
2307.5	10.26
2312.5	10.22
2352.5	10.29
2357.5	10.26

THE SPECTRUM PLOT OF WORST VALUE:

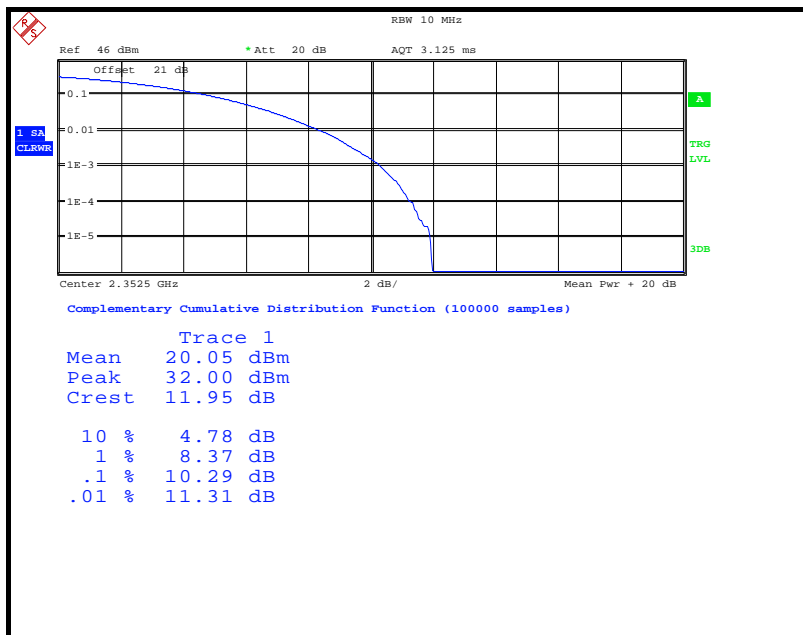



A D T

CHANNEL BANDWIDTH: 10MHz	
CHANNEL FREQUENCY (MHz)	PEAK TO AVERAGE RATIO (dB)
2310	10.77
2355	10.80

THE SPECTRUM PLOT OF WORST VALUE:

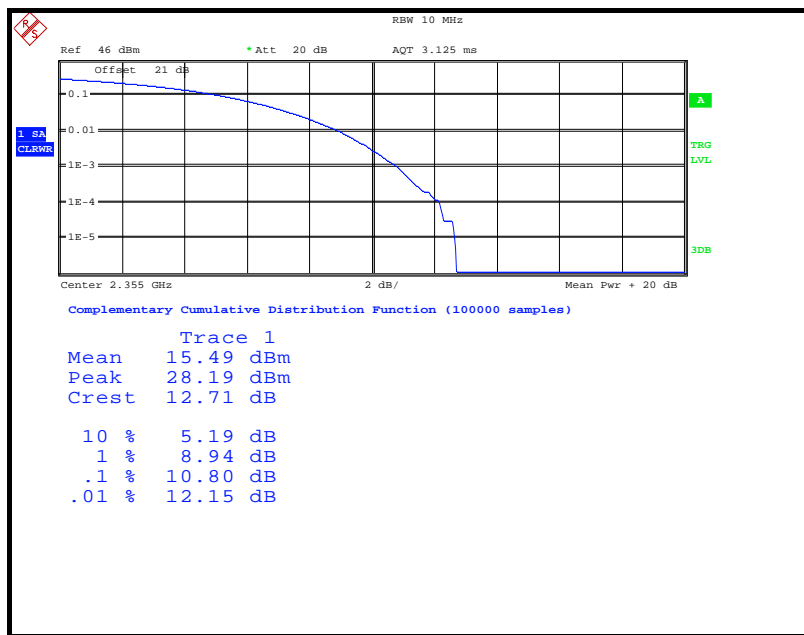



4.5 BAND EDGE MEASUREMENT

4.5.1 LIMITS OF BAND EDGE MEASUREMENT

For fixed customer premises equipment (CPE) stations operating in the 2305–2320 MHz band and the 2345–2360 MHz band transmitting with more than 2 watts per 5 megahertz average EIRP:

(i) By a factor of not less than: $43 + 10 \log (P)$ dB on all frequencies between 2305 and 2320 MHz and on all frequencies between 2345 and 2360 MHz that are outside the licensed band of operation, and not less than $75 + 10 \log (P)$ dB on all frequencies between 2320 and 2345 MHz.

(ii) By a factor of not less than: $43 + 10 \log (P)$ dB at 2305 MHz, $70 + 10 \log (P)$ dB at 2300 MHz, $72 + 10 \log (P)$ dB at 2287.5 MHz, and $75 + 10 \log (P)$ dB below 2285 MHz;

(iii) By a factor of not less than: $43 + 10 \log (P)$ dB at 2360 MHz, $55 + 10 \log (P)$ dB at 2362.5 MHz, $70 + 10 \log (P)$ dB at 2365 MHz, $72 + 10 \log (P)$ dB at 2367.5 MHz, and $75 + 10 \log (P)$ dB above 2370 MHz.

4.5.2 TEST INSTRUMENTS

DESCRIPTION & MANUFACTURER	MODEL NO.	SERIAL NO.	DATE OF CALIBRATION	DUE DATE OF CALIBRATION
Spectrum Analyzer Agilent	E4446A	MY44360124	Dec. 29, 2010	Dec. 28, 2011
RF cable	SUCOFLEX 104	274403/4	Aug. 20, 2010	Aug. 19, 2011

NOTE: The calibration interval of the above test instruments is 12 months. And the calibrations are traceable to NML/ROC and NIST/USA.

4.5.3 TEST SETUP

Same as Item 4.3.4

4.5.4 TEST PROCEDURES

- a. The EUT was set up for the rated peak power. The power was measured with Spectrum Analyzer. All measurements were done at specific channels.
- b. The center frequency of spectrum is the band edge frequency and span is 20MHz (Channel Bandwidth: 5MHz) / 30MHz (Channel Bandwidth: 10MHz). RBW of the spectrum is 51kHz (Channel Bandwidth: 5MHz) / 100kHz (Channel Bandwidth: 10MHz).
- c. Record the max trace plot into the test report.

4.5.5 EUT OPERATING CONDITION

Same as 4.1.5



4.5.6 TEST RESULTS

BAND EDGE MEASUREMENT

CHANNEL BANDWIDTH: 5MHz					
CHANNEL FREQUENCY (MHz)	Test Freq (MHz)	Correction Factor(dB)	S.G Power Value(dBm)	Total Power (dBm)	Limit (dBm)
2307.5	2303~2304	21.0	-49.1	-28.12	-23.79
	2304~2305	21.0	-42.5	-21.49	-18.40
2312.5	2320~2321	21.0	-70.5	-49.49	-45.00
2352.5	2344~2345	21.0	-70.3	-49.25	-45.00
2357.5	2360~2361	21.0	-42.8	-21.75	-17.80
	2361~2362	21.0	-50.2	-29.19	-22.60

CHANNEL BANDWIDTH: 10MHz					
CHANNEL FREQUENCY (MHz)	Test Freq (MHz)	Correction Factor(dB)	S.G Power Value(dBm)	Total Power (dBm)	Limit (dBm)
2310	2304~2305	21.0	-51.4	-30.40	-18.40
	2320~2321	21.0	-67.3	-46.32	-45.00
	2321~2322	21.0	-69.6	-48.57	-45.00
2355	2343~2344	21.0	-69.5	-48.46	-45.00
	2344~2345	21.0	-66.8	-45.81	-45.00
	2360~2361	21.0	-50.4	-29.43	-17.80



A D T

CHANNEL BANDWIDTH: 5MHz

CHANNEL 2307.5MHz





A D T

CHANNEL 2312.5MHz

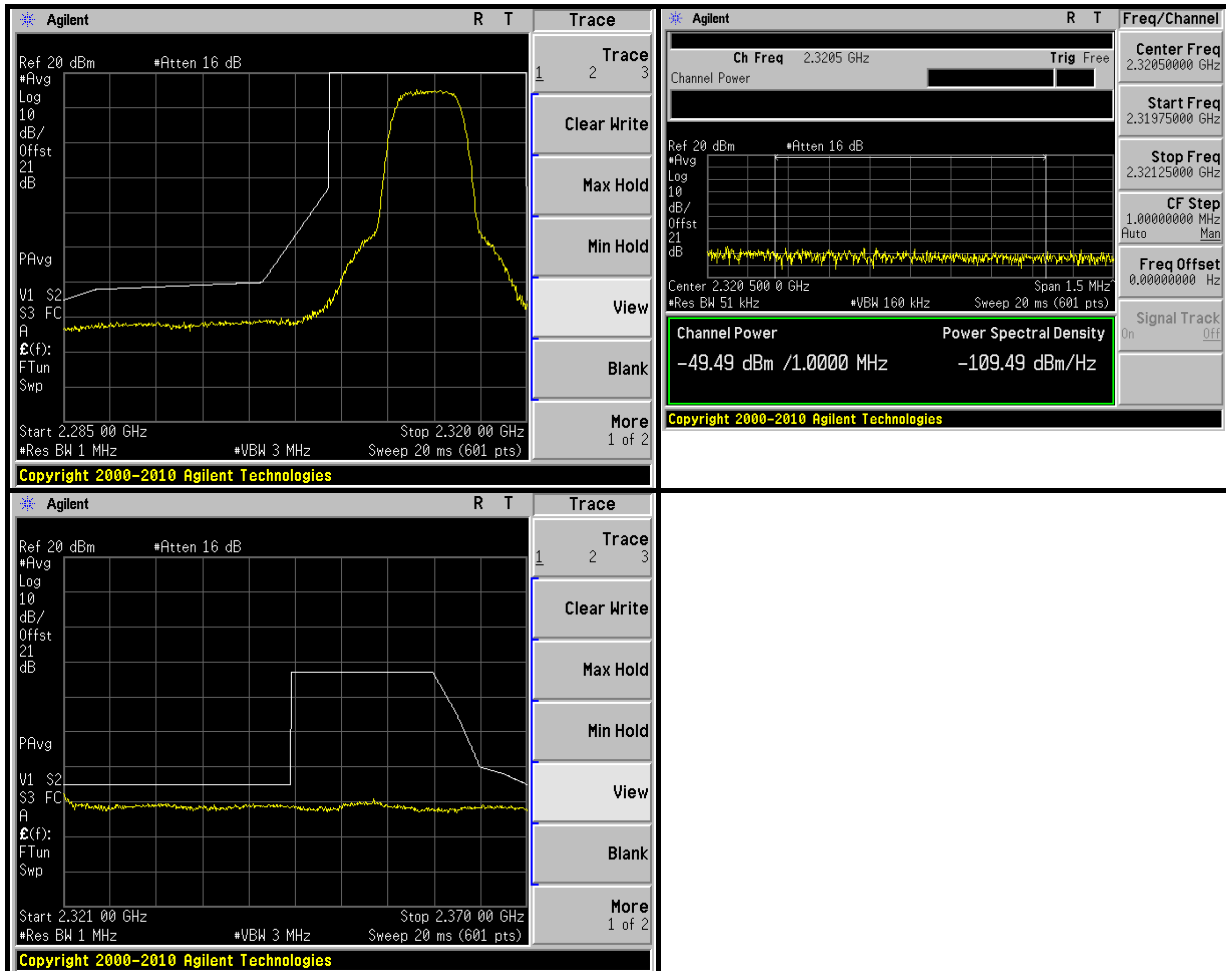



A D T

CHANNEL 2352.5MHz

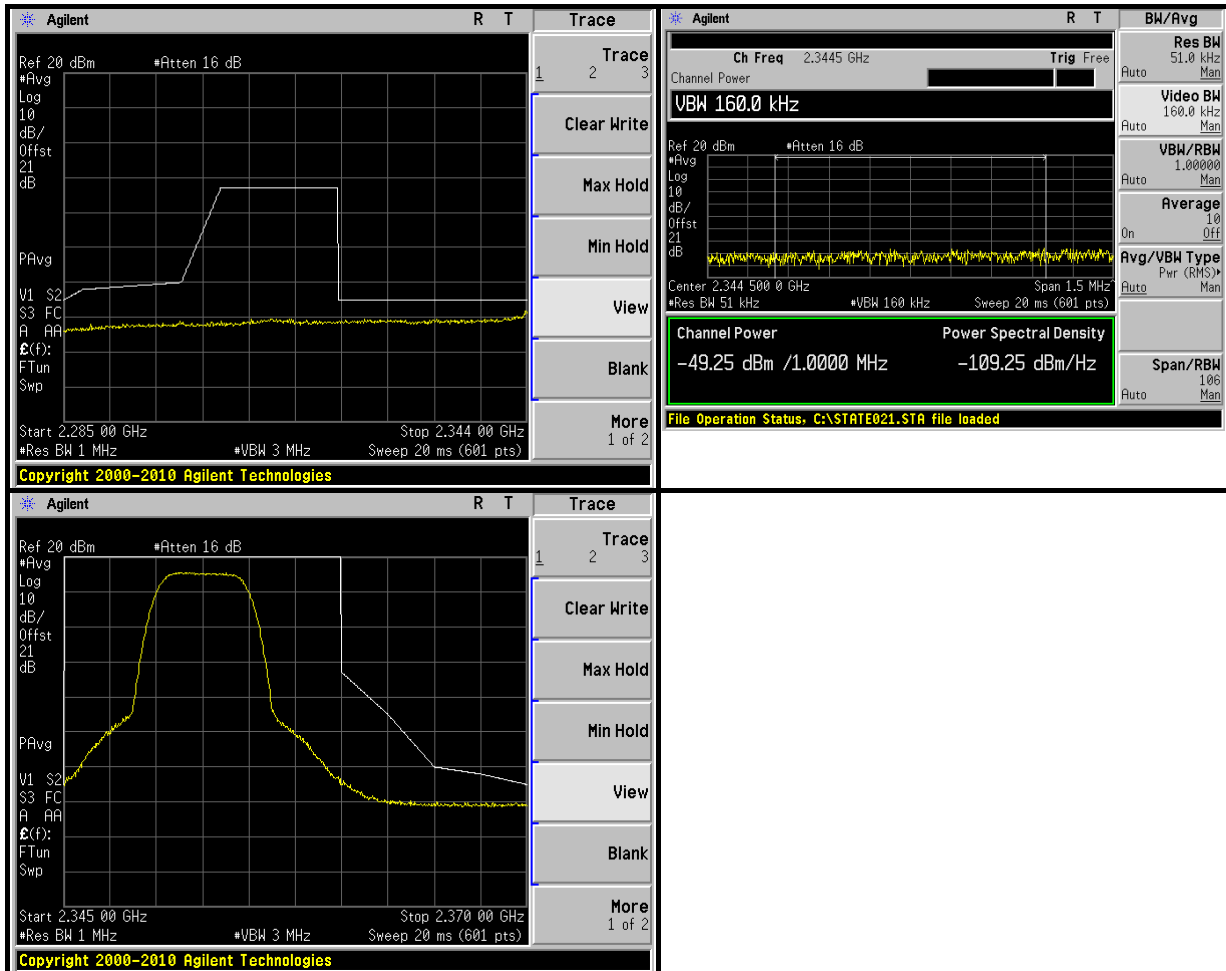



A D T

CHANNEL 2357.5MHz

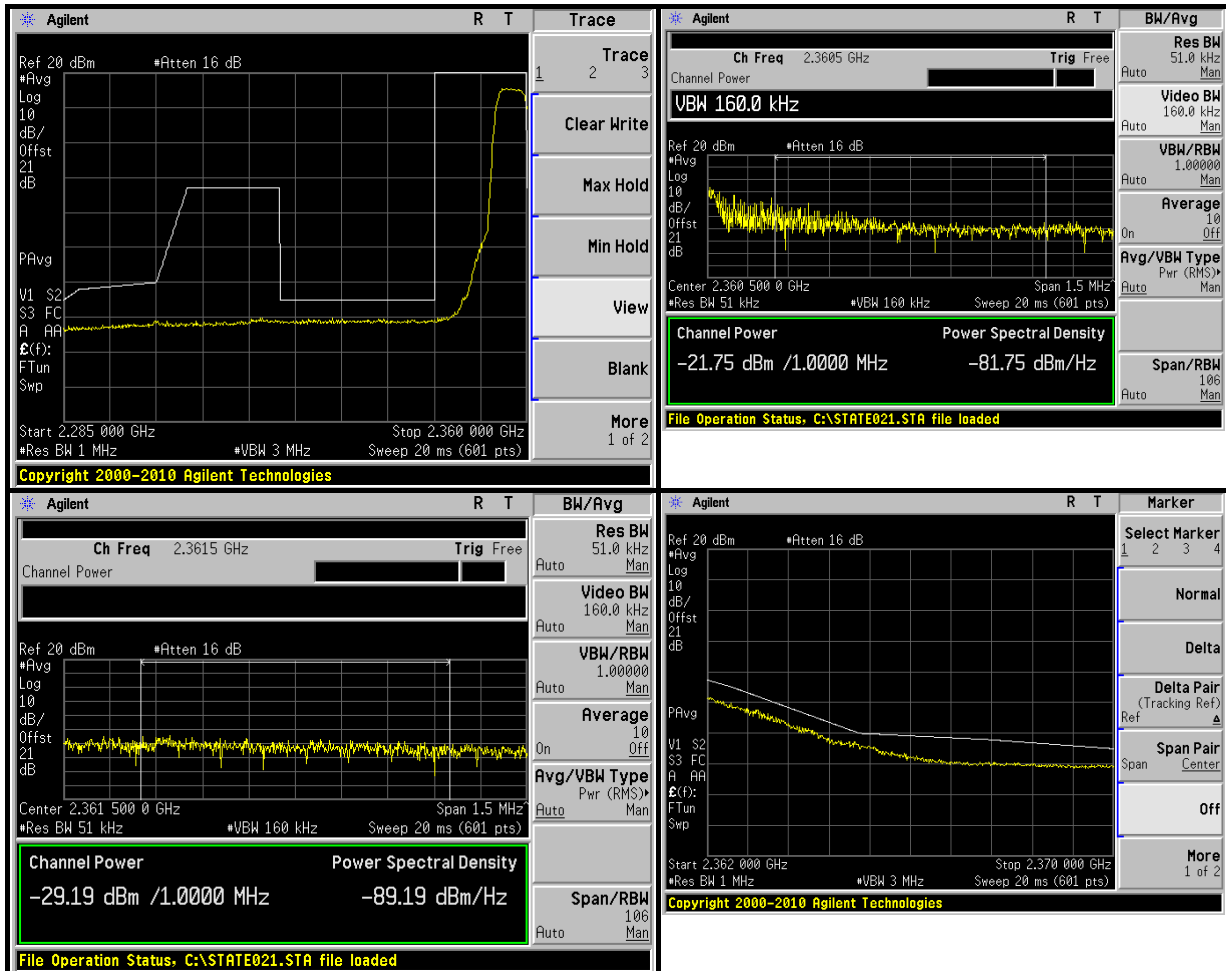



A D T

CHANNEL BANDWIDTH: 10MHz

CHANNEL 2310MHz

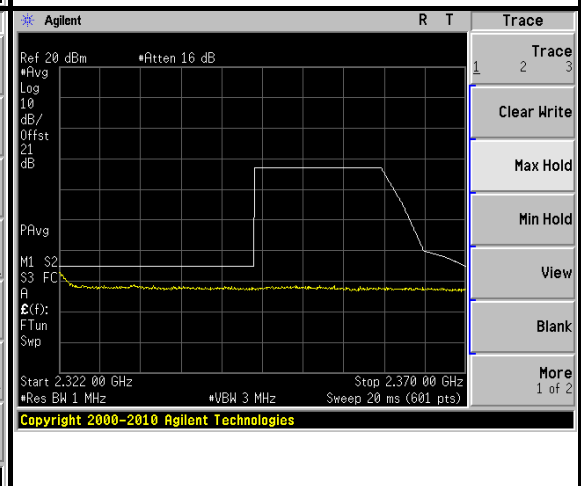
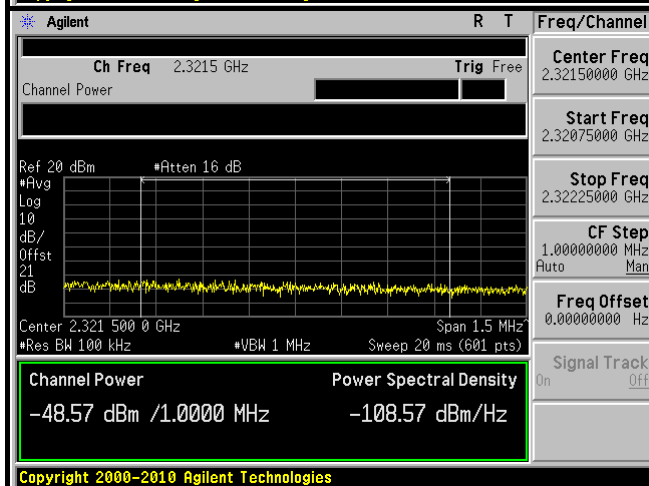
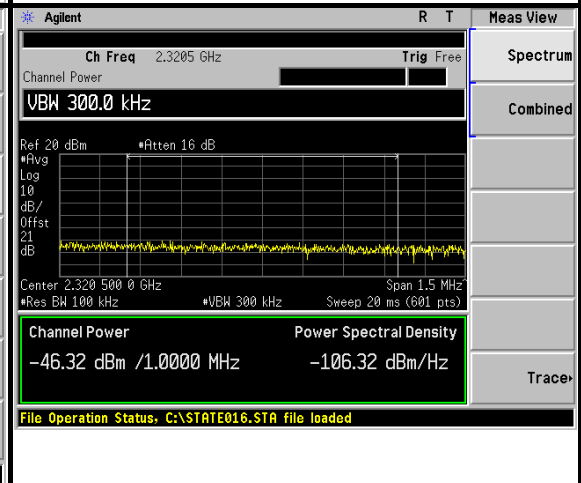
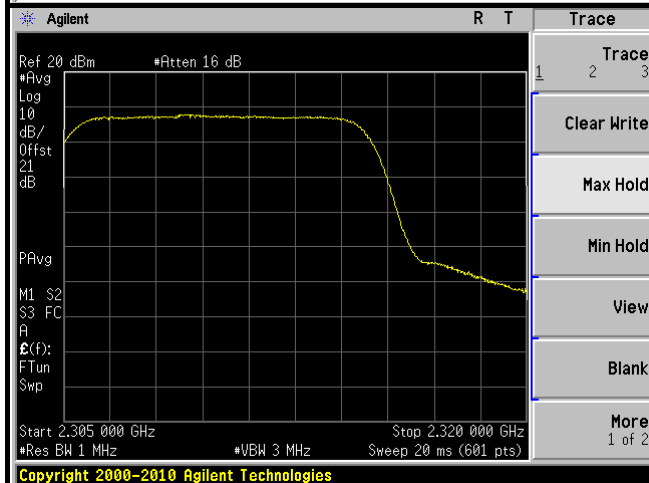
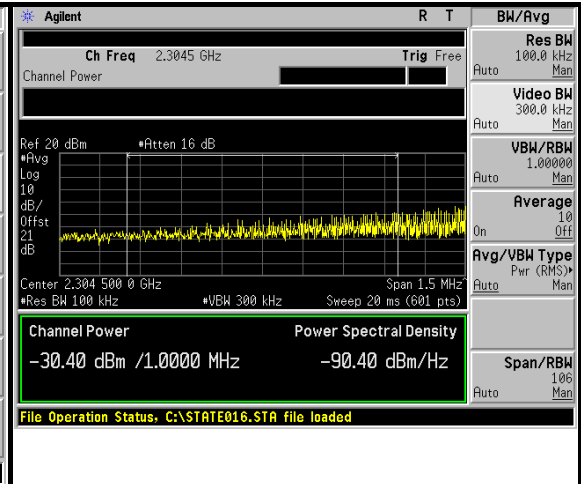
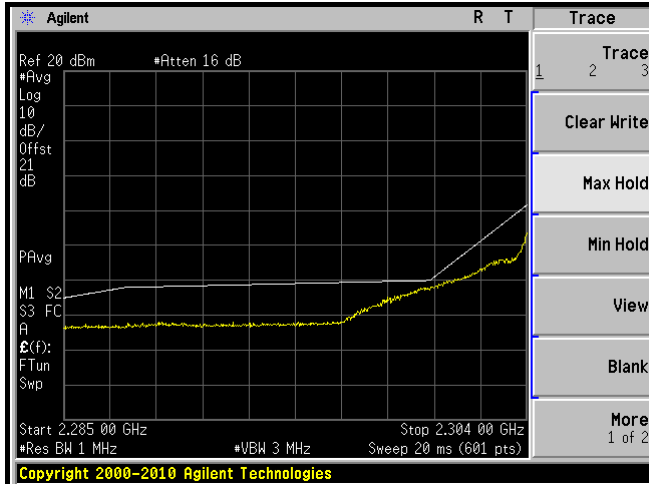



A D T

CHANNEL 2310MHz

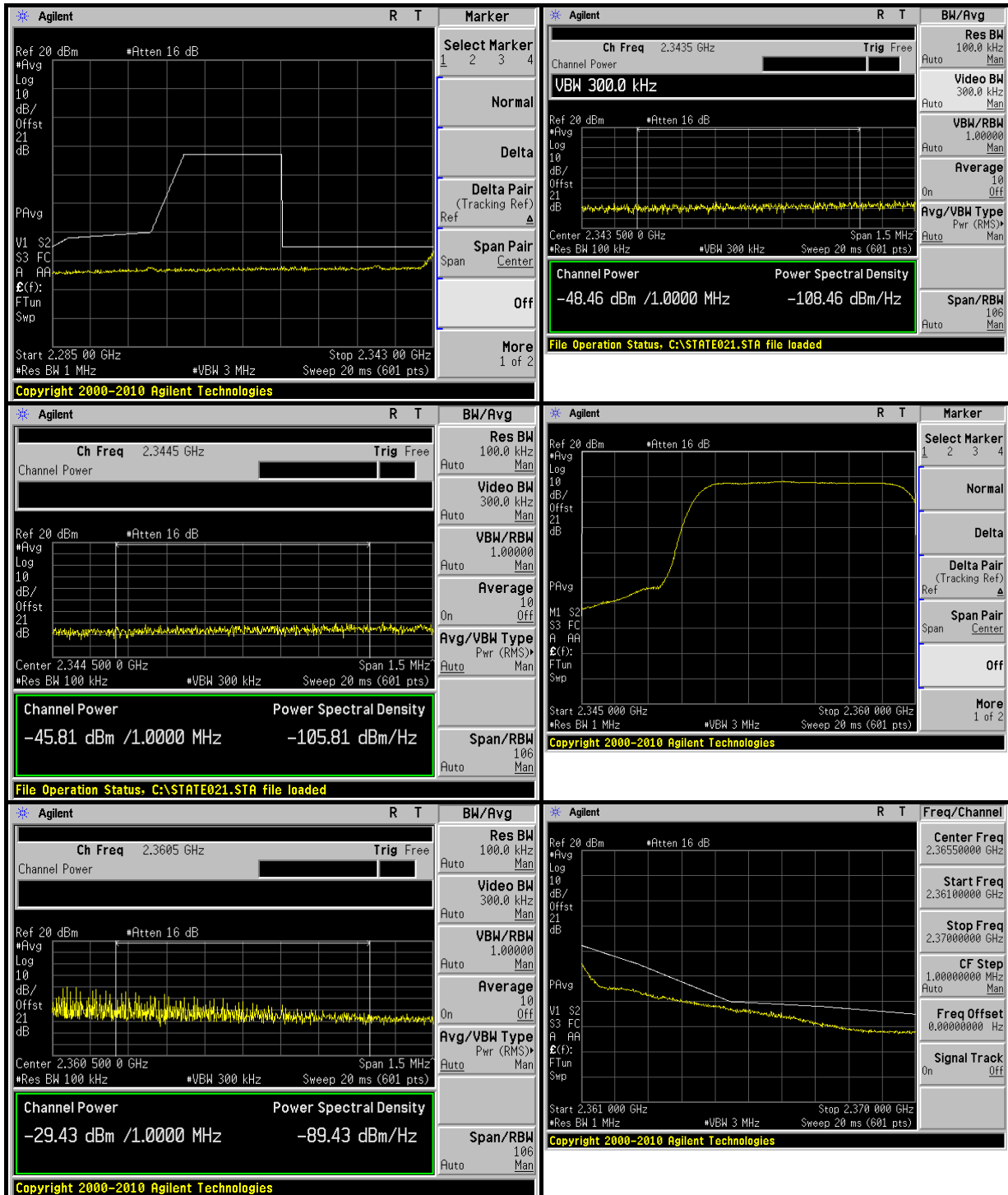

4.6 CONDUCTED SPURIOUS EMISSIONS

4.6.1 LIMITS OF CONDUCTED SPURIOUS EMISSIONS MEASUREMENT

For fixed customer premises equipment (CPE) stations operating in the 2305–2320 MHz band and the 2345–2360 MHz band transmitting with more than 2 watts per 5 megahertz average EIRP:

(i) By a factor of not less than: $43 + 10 \log (P)$ dB on all frequencies between 2305 and 2320 MHz and on all frequencies between 2345 and 2360 MHz that are outside the licensed band of operation, and not less than $75 + 10 \log (P)$ dB on all frequencies between 2320 and 2345 MHz.

(ii) By a factor of not less than: $43 + 10 \log (P)$ dB at 2305 MHz, $70 + 10 \log (P)$ dB at 2300 MHz, $72 + 10 \log (P)$ dB at 2287.5 MHz, and $75 + 10 \log (P)$ dB below 2285 MHz;

(iii) By a factor of not less than: $43 + 10 \log (P)$ dB at 2360 MHz, $55 + 10 \log (P)$ dB at 2362.5 MHz, $70 + 10 \log (P)$ dB at 2365 MHz, $72 + 10 \log (P)$ dB at 2367.5 MHz, and $75 + 10 \log (P)$ dB above 2370 MHz.

4.6.2 TEST INSTRUMENTS

DESCRIPTION & MANUFACTURER	MODEL NO.	SERIAL NO.	DATE OF CALIBRATION	DUE DATE OF CALIBRATION
Spectrum Analyzer Agilent	E4446A	MY44360124	Dec. 29, 2010	Dec. 28, 2011
RF cable	SUCOFLEX 104	274403/4	Aug. 20, 2010	Aug. 19, 2011
DC-6GHz 20dB 50W Fixed attenuator Woken	MDC9331N-20	0724	May 13, 2011	May 12, 2012
Wainwright Instruments High Pass Filter	WHKX4.5/18G -10SS	NA	NA	NA

NOTE: The calibration interval of the above test instruments is 12 months. And the calibrations are traceable to NML/ROC and NIST/USA.



A D T

4.6.3 TEST PROCEDURE

- a. All measurements were done at specific channels.
- b. When the spectrum scanned from 30MHz to 24GHz, it shall be connected to the 20dB pad attenuated the carried frequency. The spectrum set $RB = 1\text{MHz}$, $VB = 3\text{MHz}$.

4.6.4 TEST SETUP

Same as 4.3.4

4.6.5 EUT OPERATING CONDITIONS

Same as 4.1.5



A D T

4.6.6 TEST RESULTS

CONDUCTED UNWANTED EMISSIONS / CHANNEL BANDWIDTH: 5MHz

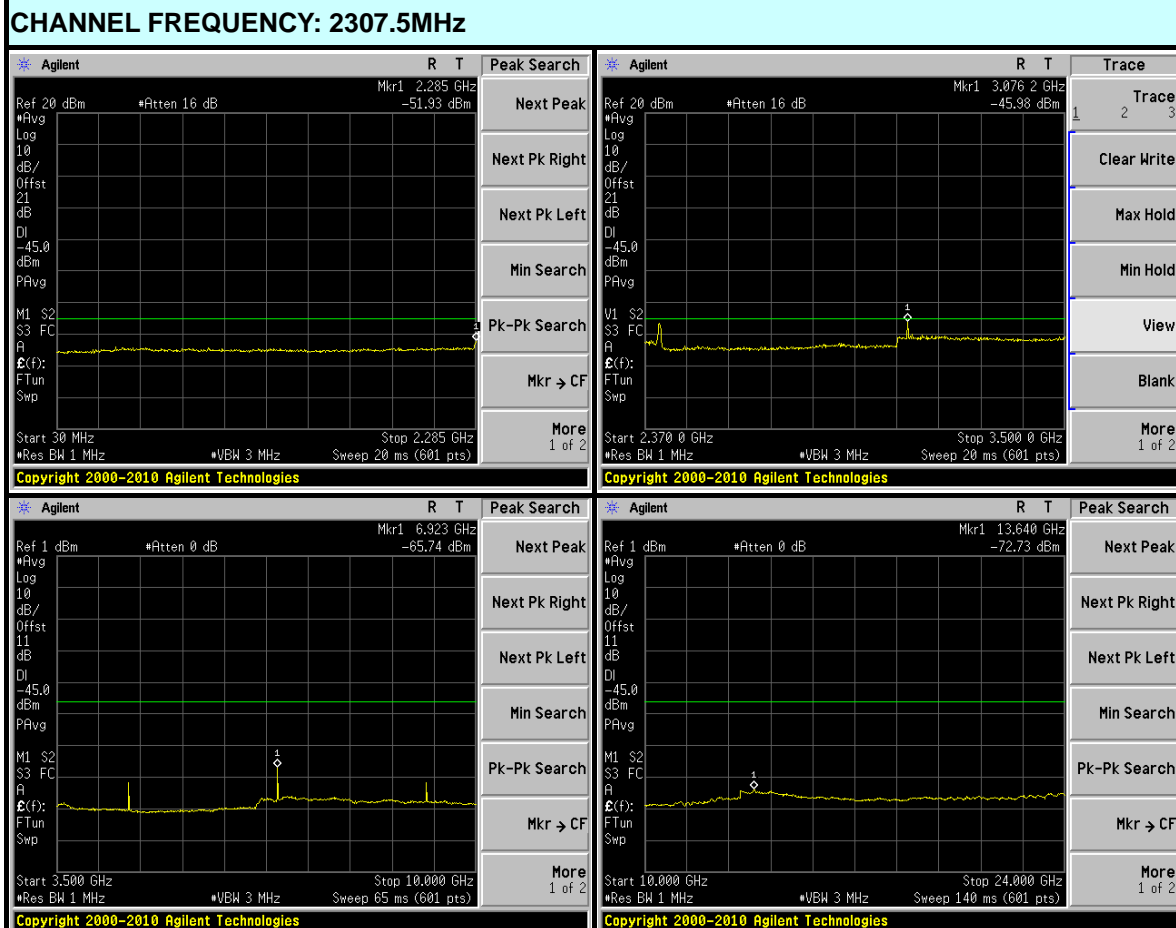



A D T

CHANNEL FREQUENCY: 2312.5MHz

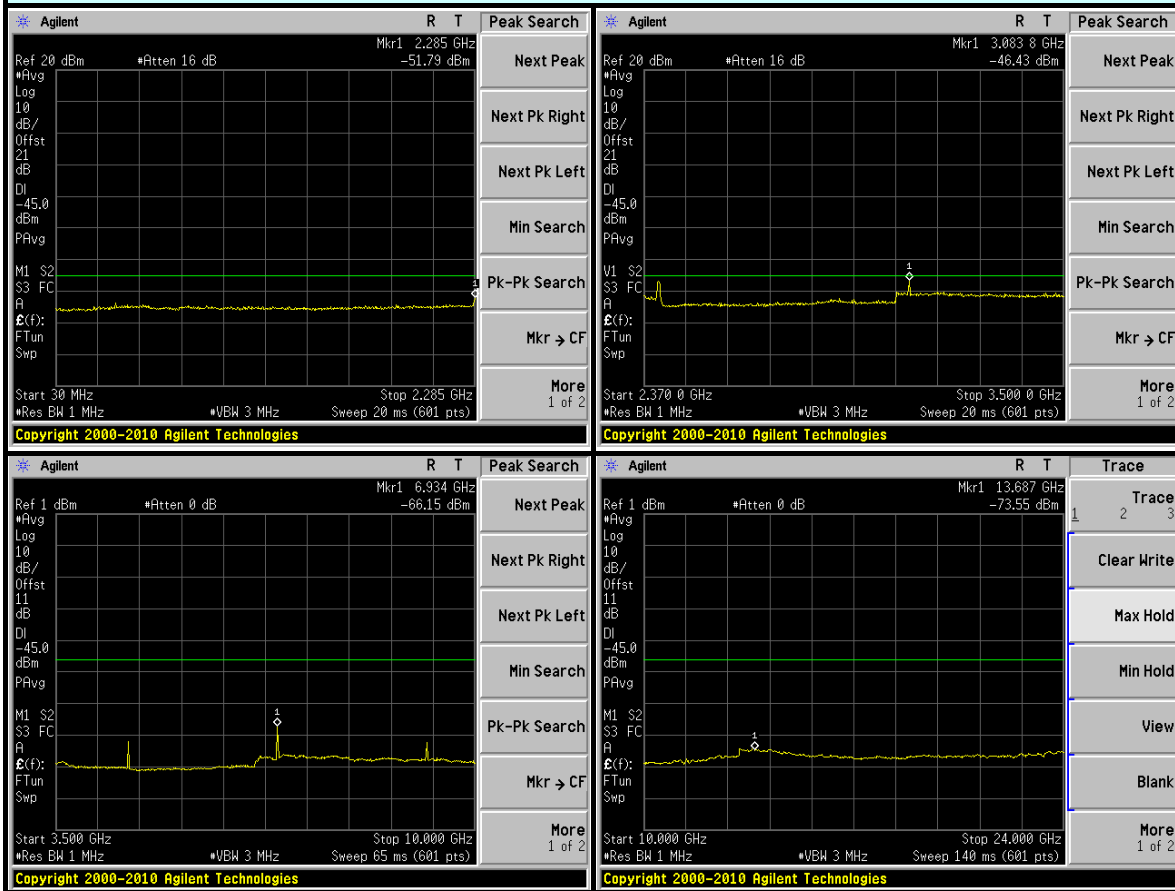



A D T

CHANNEL FREQUENCY: 2352.5MHz

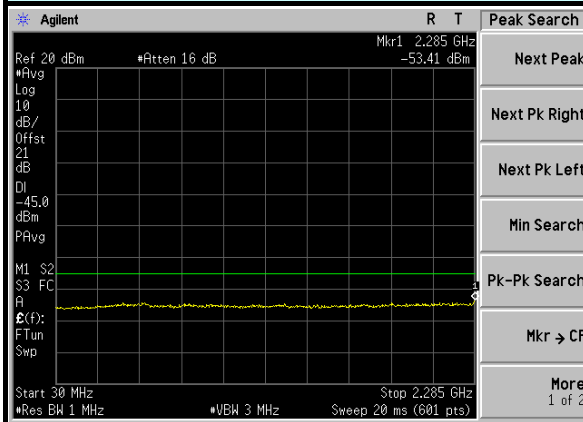

Copyright 2000-2010 Agilent Technologies

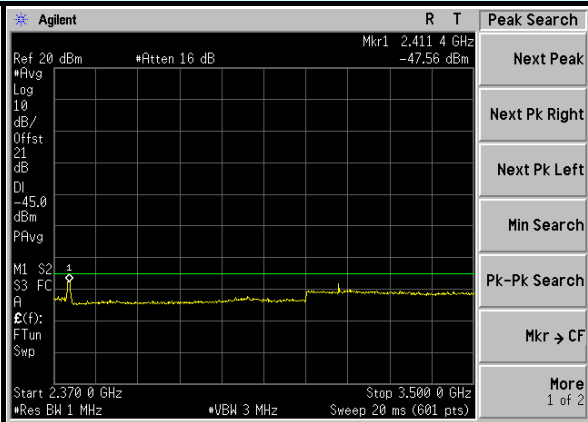

Copyright 2000-2010 Agilent Technologies

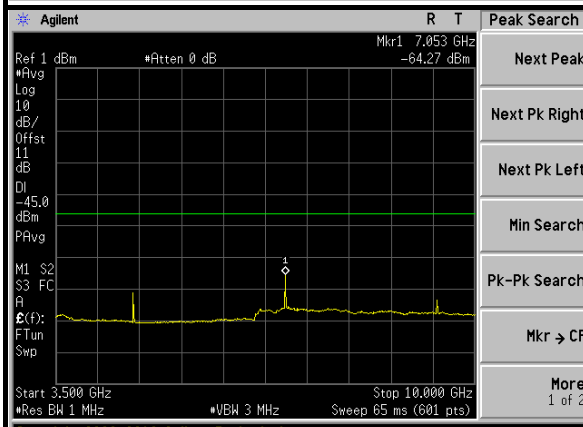

Copyright 2000-2010 Agilent Technologies

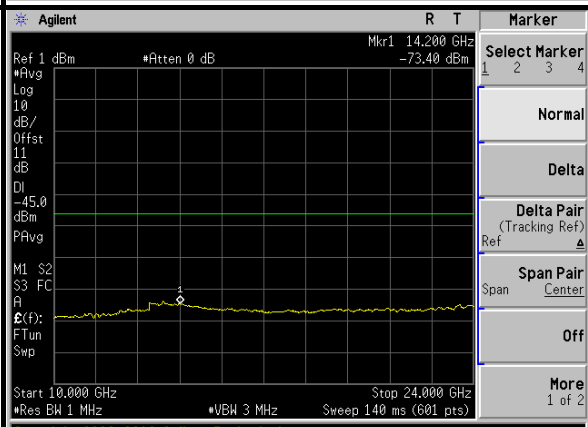

Copyright 2000-2010 Agilent Technologies



A D T

CHANNEL FREQUENCY: 2357.5MHz

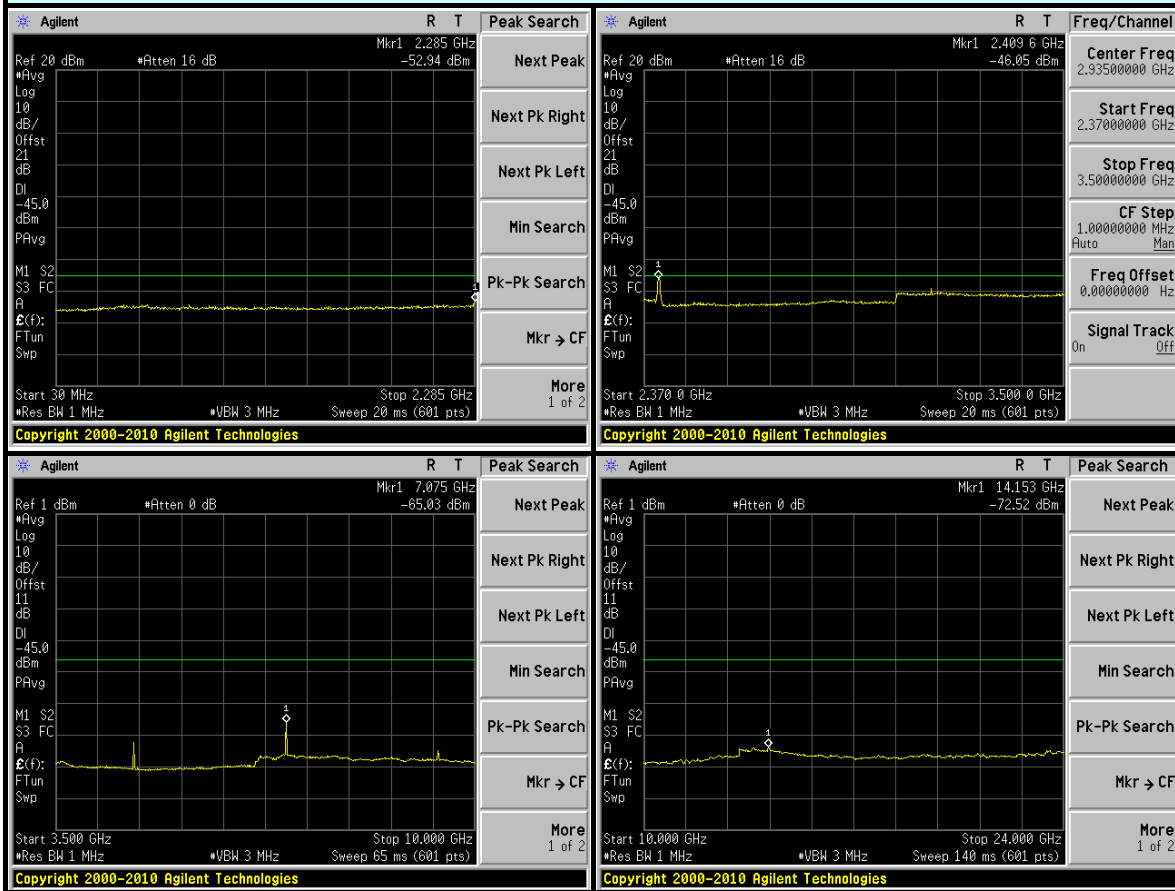



A D T

CONDUCTED UNWANTED EMISSIONS / CHANNEL BANDWIDTH: 10MHz

CHANNEL FREQUENCY: 2310MHz

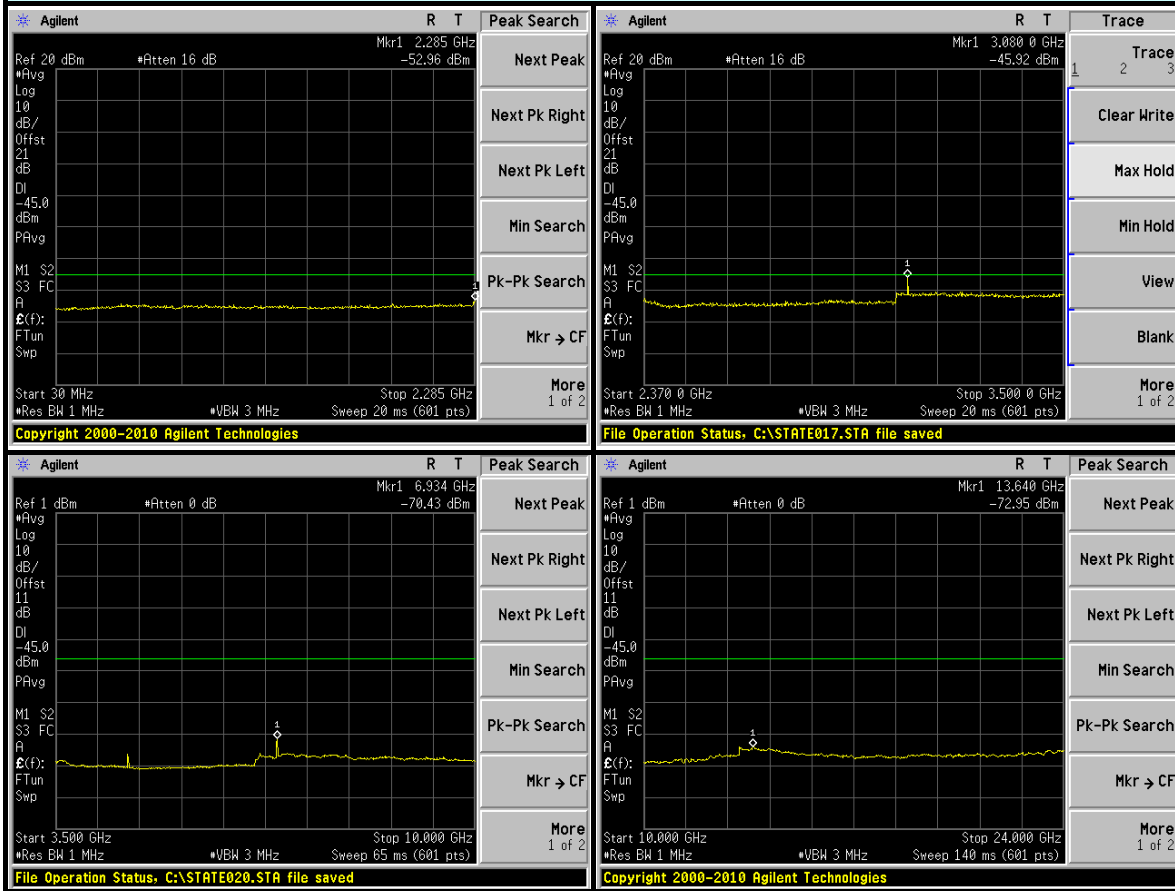



A D T

CHANNEL FREQUENCY: 2355MHZ

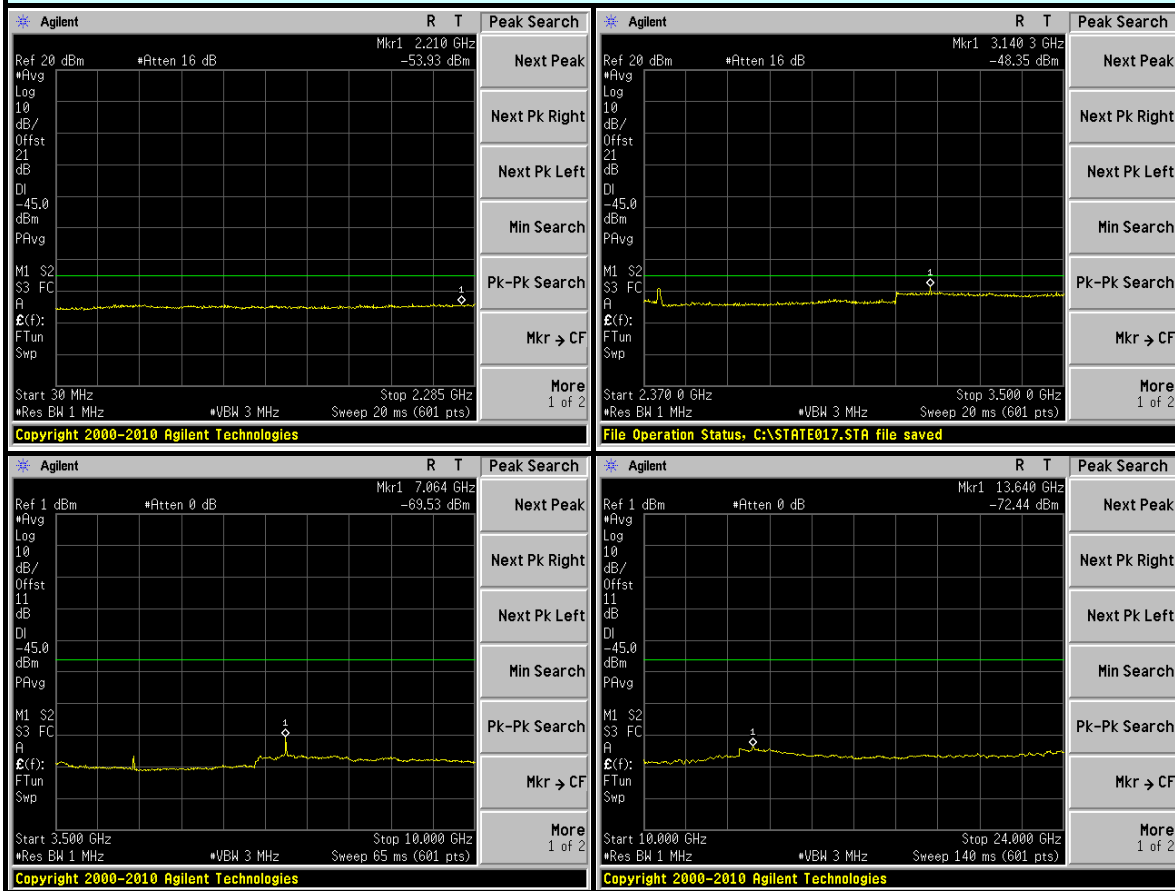



A D T

4.7 RADIATED EMISSION MEASUREMENT (BELOW 1GHz)

4.7.1 LIMITS OF RADIATED EMISSION MEASUREMENT

For fixed customer premises equipment (CPE) stations operating in the 2305–2320 MHz band and the 2345–2360 MHz band transmitting with more than 2 watts per 5 megahertz average EIRP:

- (i) By a factor of not less than: $43 + 10 \log (P)$ dB on all frequencies between 2305 and 2320 MHz and on all frequencies between 2345 and 2360 MHz that are outside the licensed band of operation, and not less than $75 + 10 \log (P)$ dB) on all frequencies between 2320 and 2345 MHz.
- (ii) By a factor of not less than: $43 + 10 \log (P)$ dB) at 2305 MHz, $70 + 10 \log (P)$ dB at 2300 MHz, $72 + 10 \log (P)$ dB at 2287.5 MHz, and $75 + 10 \log (P)$ dB below 2285 MHz;
- (iii) By a factor of not less than: $43 + 10 \log (P)$ dB at 2360 MHz, $55 + 10 \log (P)$ dB at 2362.5 MHz, $70 + 10 \log (P)$ dB at 2365 MHz, $72 + 10 \log (P)$ dB at 2367.5 MHz, and $75 + 10 \log (P)$ dB) above 2370 MHz.



A D T

4.7.2 TEST INSTRUMENTS

DESCRIPTION & MANUFACTURER	MODEL NO.	SERIAL NO.	DATE OF CALIBRATION	DUE DATE OF CALIBRATION
Test Receiver ROHDE & SCHWARZ	ESI7	838496/016	Dec. 27, 2010	Dec. 26, 2011
Spectrum Analyzer ROHDE & SCHWARZ	FSU43	100115	Aug. 02, 2010	Aug. 01, 2011
BILOG Antenna SCHWARZBECK	VULB9168	9168-155	Apr. 12, 2011	Apr. 11, 2012
HORN Antenna SCHWARZBECK	BBHA 9120D	9120D-408	Jan. 06, 2011	Jan. 05, 2012
HORN Antenna SCHWARZBECK	BBHA 9170	BBHA9170243	Dec. 27, 2010	Dec. 26, 2011
Preamplifier Agilent	8449B	3008A01961	Nov. 02, 2010	Nov. 01, 2011
Preamplifier Agilent	8447D	2944A10738	Nov. 02, 2010	Nov. 01, 2011
RF signal cable HUBER+SUHNNER	SUCOFLEX 104	250792/4	Sep. 03, 2010	Sep. 02, 2011
RF signal cable HUBER+SUHNNER	SUCOFLEX 104	283397/4	Sep. 03, 2010	Sep. 02, 2011
RF signal cable HUBER+SUHNNER	SUCOFLEX 104	295012/4	Sep. 03, 2010	Sep. 02, 2011
Software ADT.	ADT_Radiated_ V7.6.15.9.2	NA	NA	NA
Antenna Tower inn-co GmbH	MA 4000	010303	NA	NA
Antenna Tower Controller inn-co GmbH	CO2000	019303	NA	NA
Turn Table ADT.	TT100.	TT93021704	NA	NA
Turn Table Controller ADT.	SC100.	SC93021704	NA	NA

- NOTE:**
1. The calibration interval of the above test instruments is 12 months and the calibrations are traceable to NML/ROC and NIST/USA.
 2. The test was performed in HwaYa Chamber 4.
 3. The horn antenna and HP preamplifier (model: 8449B) are used only for the measurement of emission frequency above 1GHz if tested.
 4. The FCC Site Registration No. is 988962.
 5. The IC Site Registration No. is IC7450F-4.



A D T

4.7.3 TEST PROCEDURES

- a. The power was measured with R&S Spectrum Analyzer. All measurements were done at specific channels.
- b. Substitution method is used for E.I.R.P measurement. In the semi-anechoic chamber, EUT placed on the 0.8m height of Turn Table, rotated the table around 360 degrees to search the maximum radiation power and receiver antenna shall be rotated vertical and horizontal polarization and moved height from 1m to 4m to find the maximum polar radiated power. The “Read Value” is the spectrum reading the maximum power value.
- c. The substitution antenna is substituted for EUT at the same position and signals generator export the CW signal to the substitution antenna via a TX cable. Rotated the Turn Table and moved receiving antenna to find the maximum radiation power. Adjust output power level of S.G to get a Value of spectrum reading equal to “Read Value “ of step b. Record the power level of S.G
- d. $EIRP = \text{Output power level of S.G} - \text{TX cable loss} + \text{Antenna gain of substitution antenna}$.

NOTE: The resolution bandwidth and video bandwidth of test receiver/spectrum analyzer is 1MHz/3MHz

4.7.4 DEVIATION FROM TEST STANDARD

No deviation

4.7.5 TEST SETUP

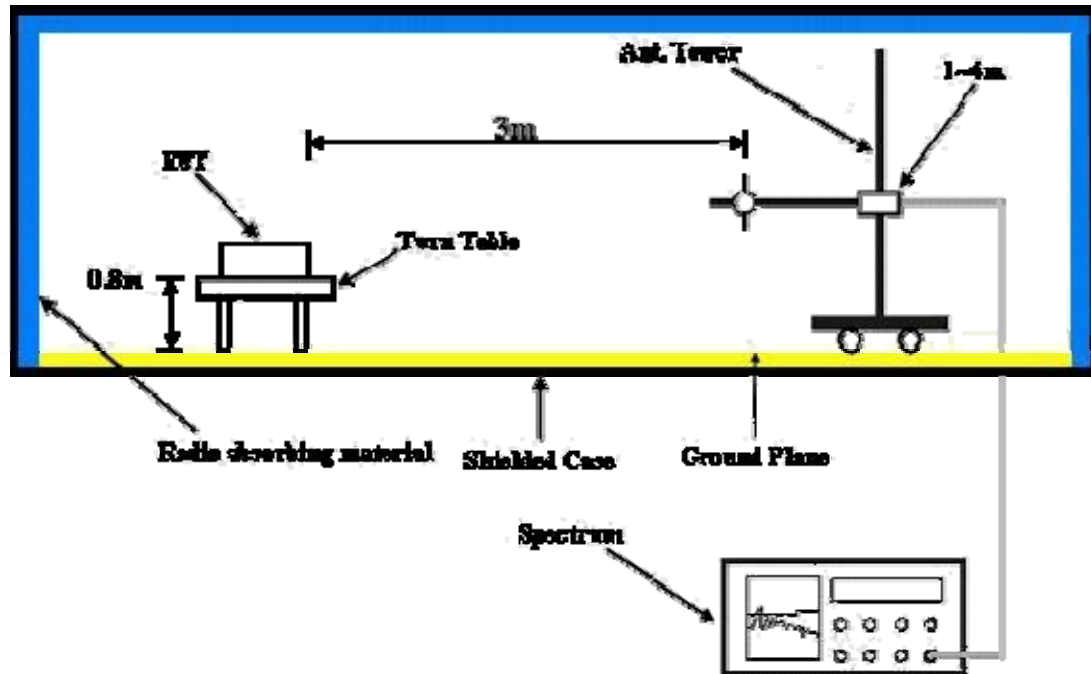

For the actual test configuration, please refer to the related item – Photographs of the Test Configuration.

4.7.6 EUT OPERATING CONDITIONS

Same as 4.1.5



A D T

4.7.7 TEST RESULTS

CHANNEL BANDWIDTH: 5MHz

BELOW 1GHz WORST-CASE DATA (TEST MODE A)

CHANNEL FREQUENCY: 2312.5MHz						
ANTENNA POLARITY & TEST DISTANCE: HORIZONTAL AT 3 m						
NO.	FREQ. (MHz)	EMISSION LEVEL (dBuV)	LIMIT (dBm)	S.G POWER VALUE (dBm)	CORRECTION FACTOR (dB)	POWER VALUE (dBm)
1	101.92	28.6	-45.0	-58.3	-7.7	-66.0
2	144.69	34.3	-45.0	-52.7	-7.7	-60.4
3	185.51	27.2	-45.0	-59.8	-7.7	-67.5
4	350.74	28.2	-45.0	-58.6	-7.8	-66.4
5	500.42	29.7	-45.0	-56.4	-7.8	-64.2
6	550.96	28.6	-45.0	-58.0	-7.8	-65.8
ANTENNA POLARITY & TEST DISTANCE: VERTICAL AT 3 m						
NO.	FREQ. (MHz)	EMISSION LEVEL (dBuV)	LIMIT (dBm)	S.G POWER VALUE (dBm)	CORRECTION FACTOR (dB)	POWER VALUE (dBm)
1	37.78	40.2	-45.0	-47.0	-7.7	-54.7
2	78.60	32.9	-45.0	-54.2	-7.7	-61.9
3	138.86	27.3	-45.0	-59.8	-7.7	-67.5
4	350.74	24.4	-45.0	-62.2	-7.8	-70.0
5	521.80	23.8	-45.0	-63.2	-7.8	-71.0
6	685.09	24.4	-45.0	-62.1	-7.8	-69.9

NOTE: Power Value (dBum) = S.G Power Value (dBm) + Correction Factor (dB).



A D T

CHANNEL FREQUENCY: 2357.5MHz						
ANTENNA POLARITY & TEST DISTANCE: HORIZONTAL AT 3 m						
NO.	FREQ. (MHz)	EMISSION LEVEL (dBuV)	LIMIT (dBm)	S.G POWER VALUE (dBm)	CORRECTION FACTOR (dB)	POWER VALUE (dBm)
1	39.72	25.4	-45.0	-61.6	-7.7	-69.3
2	144.69	33.2	-45.0	-54.0	-7.7	-61.7
3	232.16	22.1	-45.0	-64.3	-7.7	-72.0
4	350.74	25.2	-45.0	-61.3	-7.8	-69.1
5	500.42	26.7	-45.0	-59.8	-7.8	-67.6
6	550.96	27.5	-45.0	-59.6	-7.8	-67.4
ANTENNA POLARITY & TEST DISTANCE: VERTICAL AT 3 m						
NO.	FREQ. (MHz)	EMISSION LEVEL (dBuV)	LIMIT (dBm)	S.G POWER VALUE (dBm)	CORRECTION FACTOR (dB)	POWER VALUE (dBm)
1	39.72	41.4	-45.0	-45.4	-7.7	-53.1
2	78.60	33.9	-45.0	-52.6	-7.7	-60.3
3	138.86	27.0	-45.0	-60.1	-7.7	-67.8
4	350.74	24.7	-45.0	-61.8	-7.8	-69.6
5	517.92	24.8	-45.0	-62.1	-7.8	-69.9
6	679.26	24.5	-45.0	-62.6	-7.8	-70.4

NOTE: Power Value (dBum) = S.G Power Value (dBm) + Correction Factor (dB).



A D T

BELOW 1GHz WORST-CASE DATA (TEST MODE B)

CHANNEL FREQUENCY: 2312.5MHz						
ANTENNA POLARITY & TEST DISTANCE: HORIZONTAL AT 3 m						
NO.	FREQ. (MHz)	EMISSION LEVEL (dBuV)	LIMIT (dBm)	S.G POWER VALUE (dBm)	CORRECTION FACTOR (dB)	POWER VALUE (dBm)
1	101.92	32.7	-45.0	-53.9	-7.7	-61.6
2	138.86	32.9	-45.0	-54.0	-7.7	-61.7
3	239.94	24.1	-45.0	-63.1	-7.7	-70.8
4	352.69	26.1	-45.0	-60.4	-7.8	-68.2
5	405.17	25.9	-45.0	-60.6	-7.8	-68.4
6	550.96	28.8	-45.0	-58.1	-7.8	-65.9
ANTENNA POLARITY & TEST DISTANCE: VERTICAL AT 3 m						
NO.	FREQ. (MHz)	EMISSION LEVEL (dBuV)	LIMIT (dBm)	S.G POWER VALUE (dBm)	CORRECTION FACTOR (dB)	POWER VALUE (dBm)
1	39.72	43.6	-45.0	-42.8	-7.7	-50.5
2	61.10	34.4	-45.0	-52.4	-7.7	-60.1
3	111.64	29.5	-45.0	-57.6	-7.7	-65.3
4	136.91	27.8	-45.0	-58.9	-7.7	-66.6
5	352.69	22.8	-45.0	-63.4	-7.8	-71.2
6	519.86	23.9	-45.0	-62.7	-7.8	-70.5

NOTE: Power Value (dBum) = S.G Power Value (dBm) + Correction Factor (dB).



A D T

CHANNEL FREQUENCY: 2357.5MHz						
ANTENNA POLARITY & TEST DISTANCE: HORIZONTAL AT 3 m						
NO.	FREQ. (MHz)	EMISSION LEVEL (dBuV)	LIMIT (dBm)	S.G POWER VALUE (dBm)	CORRECTION FACTOR (dB)	POWER VALUE (dBm)
1	59.16	29.1	-45.0	-57.5	-7.7	-65.2
2	101.92	32.7	-45.0	-54.0	-7.7	-61.7
3	138.86	32.9	-45.0	-54.2	-7.7	-61.9
4	249.66	24.6	-45.0	-62.4	-7.7	-70.1
5	348.80	25.6	-45.0	-61.1	-7.8	-68.9
6	550.96	28.1	-45.0	-58.1	-7.8	-65.9
ANTENNA POLARITY & TEST DISTANCE: VERTICAL AT 3 m						
NO.	FREQ. (MHz)	EMISSION LEVEL (dBuV)	LIMIT (dBm)	S.G POWER VALUE (dBm)	CORRECTION FACTOR (dB)	POWER VALUE (dBm)
1	37.78	42.4	-45.0	-44.6	-7.7	-52.3
2	61.10	36.3	-45.0	-50.6	-7.7	-58.3
3	88.32	31.2	-45.0	-55.2	-7.7	-62.9
4	138.86	26.3	-45.0	-60.0	-7.7	-67.7
5	358.52	23.4	-45.0	-63.3	-7.8	-71.1
6	449.88	24.6	-45.0	-62.1	-7.8	-69.9

NOTE: Power Value (dBum) = S.G Power Value (dBm) + Correction Factor (dB).



A D T

CHANNEL BANDWIDTH: 10MHz

BELOW 1GHz WORST-CASE DATA (TEST MODE A)

CHANNEL FREQUENCY: 2310MHz						
ANTENNA POLARITY & TEST DISTANCE: HORIZONTAL AT 3 m						
NO.	FREQ. (MHz)	EMISSION LEVEL (dBuV)	LIMIT (dBm)	S.G POWER VALUE (dBm)	CORRECTION FACTOR (dB)	POWER VALUE (dBm)
1	37.78	26.1	-45.0	-60.8	-7.7	-68.5
2	101.92	29.6	-45.0	-57.5	-7.7	-65.2
3	144.69	34.4	-45.0	-52.4	-7.7	-60.1
4	350.74	25.7	-45.0	-60.7	-7.8	-68.5
5	500.42	28.4	-45.0	-58.4	-7.8	-66.2
6	550.96	28.8	-45.0	-57.7	-7.8	-65.5
ANTENNA POLARITY & TEST DISTANCE: VERTICAL AT 3 m						
NO.	FREQ. (MHz)	EMISSION LEVEL (dBuV)	LIMIT (dBm)	S.G POWER VALUE (dBm)	CORRECTION FACTOR (dB)	POWER VALUE (dBm)
1	39.72	39.8	-45.0	-46.6	-7.7	-54.3
2	78.60	33.8	-45.0	-53.0	-7.7	-60.7
3	138.86	27.5	-45.0	-58.9	-7.7	-66.6
4	352.69	25.4	-45.0	-60.8	-7.8	-68.6
5	426.55	21.9	-45.0	-64.8	-7.8	-72.6
6	525.69	24.9	-45.0	-61.9	-7.8	-69.7

NOTE: Power Value (dBum) = S.G Power Value (dBm) + Correction Factor (dB).



A D T

CHANNEL FREQUENCY: 2355MHz						
ANTENNA POLARITY & TEST DISTANCE: HORIZONTAL AT 3 m						
NO.	FREQ. (MHz)	EMISSION LEVEL (dBuV)	LIMIT (dBm)	S.G POWER VALUE (dBm)	CORRECTION FACTOR (dB)	POWER VALUE (dBm)
1	37.78	25.8	-45.0	-61.3	-7.7	-69.0
2	101.92	28.8	-45.0	-58.1	-7.7	-65.8
3	144.69	34.3	-45.0	-52.0	-7.7	-59.7
4	185.51	26.7	-45.0	-60.0	-7.7	-67.7
5	350.74	25.2	-45.0	-60.8	-7.8	-68.6
6	550.96	27.0	-45.0	-59.2	-7.8	-67.0
ANTENNA POLARITY & TEST DISTANCE: VERTICAL AT 3 m						
NO.	FREQ. (MHz)	EMISSION LEVEL (dBuV)	LIMIT (dBm)	S.G POWER VALUE (dBm)	CORRECTION FACTOR (dB)	POWER VALUE (dBm)
1	37.78	41.4	-45.0	-45.4	-7.7	-53.1
2	78.60	33.8	-45.0	-52.5	-7.7	-60.2
3	138.86	26.9	-45.0	-60.1	-7.7	-67.8
4	259.38	34.5	-45.0	-52.4	-7.7	-60.1
5	350.74	26.3	-45.0	-60.5	-7.8	-68.3
6	500.42	27.0	-45.0	-59.9	-7.8	-67.7

NOTE: Power Value (dBum) = S.G Power Value (dBm) + Correction Factor (dB).



A D T

BELOW 1GHz WORST-CASE DATA (TEST MODE B)

CHANNEL FREQUENCY: 2310MHz						
ANTENNA POLARITY & TEST DISTANCE: HORIZONTAL AT 3 m						
NO.	FREQ. (MHz)	EMISSION LEVEL (dBuV)	LIMIT (dBm)	S.G POWER VALUE (dBm)	CORRECTION FACTOR (dB)	POWER VALUE (dBm)
1	101.92	31.6	-45.0	-55.4	-7.7	-63.1
2	138.86	32.6	-45.0	-54.0	-7.7	-61.7
3	185.51	28.1	-45.0	-58.1	-7.7	-65.8
4	239.94	25.2	-45.0	-61.3	-7.7	-69.0
5	352.69	25.4	-45.0	-61.1	-7.8	-68.9
6	550.96	27.0	-45.0	-60.2	-7.8	-68.0
ANTENNA POLARITY & TEST DISTANCE: VERTICAL AT 3 m						
NO.	FREQ. (MHz)	EMISSION LEVEL (dBuV)	LIMIT (dBm)	S.G POWER VALUE (dBm)	CORRECTION FACTOR (dB)	POWER VALUE (dBm)
1	39.72	43.9	-45.0	-43.3	-7.7	-51.0
2	61.10	35.7	-45.0	-51.0	-7.7	-58.7
3	101.92	31.6	-45.0	-54.9	-7.7	-62.6
4	140.80	27.9	-45.0	-58.9	-7.7	-66.6
5	352.69	23.4	-45.0	-63.5	-7.8	-71.3
6	422.67	24.0	-45.0	-62.5	-7.8	-70.3

NOTE: Power Value (dBum) = S.G Power Value (dBm) + Correction Factor (dB).



A D T

CHANNEL FREQUENCY: 2355MHz						
ANTENNA POLARITY & TEST DISTANCE: HORIZONTAL AT 3 m						
NO.	FREQ. (MHz)	EMISSION LEVEL (dBuV)	LIMIT (dBm)	S.G POWER VALUE (dBm)	CORRECTION FACTOR (dB)	POWER VALUE (dBm)
1	101.92	32.2	-45.0	-54.5	-7.7	-62.2
2	138.86	33.6	-45.0	-53.2	-7.7	-60.9
3	185.51	28.6	-45.0	-58.4	-7.7	-66.1
4	358.52	25.3	-45.0	-61.4	-7.8	-69.2
5	401.28	26.1	-45.0	-60.6	-7.8	-68.4
6	550.96	27.5	-45.0	-59.2	-7.8	-67.0
ANTENNA POLARITY & TEST DISTANCE: VERTICAL AT 3 m						
NO.	FREQ. (MHz)	EMISSION LEVEL (dBuV)	LIMIT (dBm)	S.G POWER VALUE (dBm)	CORRECTION FACTOR (dB)	POWER VALUE (dBm)
1	39.72	43.0	-45.0	-43.9	-7.7	-51.6
2	61.10	34.7	-45.0	-52.1	-7.7	-59.8
3	101.92	30.8	-45.0	-55.9	-7.7	-63.6
4	138.86	26.4	-45.0	-60.0	-7.7	-67.7
5	358.52	23.4	-45.0	-63.2	-7.8	-71.0
6	449.88	22.9	-45.0	-63.5	-7.8	-71.3

NOTE: Power Value (dBum) = S.G Power Value (dBm) + Correction Factor (dB).

4.8 RADIATED EMISSION MEASUREMENT (ABOVE 1GHz)

4.8.1 LIMITS OF RADIATED EMISSION MEASUREMENT

For fixed customer premises equipment (CPE) stations operating in the 2305–2320 MHz band and the 2345–2360 MHz band transmitting with more than 2 watts per 5 megahertz average EIRP:

(i) By a factor of not less than: $43 + 10 \log (P)$ dB on all frequencies between 2305 and 2320 MHz and on all frequencies between 2345 and 2360 MHz that are outside the licensed band of operation, and not less than $75 + 10 \log (P)$ dB on all frequencies between 2320 and 2345 MHz.

(ii) By a factor of not less than: $43 + 10 \log (P)$ dB at 2305 MHz, $70 + 10 \log (P)$ dB at 2300 MHz, $72 + 10 \log (P)$ dB at 2287.5 MHz, and $75 + 10 \log (P)$ dB below 2285 MHz;

(iii) By a factor of not less than: $43 + 10 \log (P)$ dB at 2360 MHz, $55 + 10 \log (P)$ dB at 2362.5 MHz, $70 + 10 \log (P)$ dB at 2365 MHz, $72 + 10 \log (P)$ dB at 2367.5 MHz, and $75 + 10 \log (P)$ dB above 2370 MHz.

4.8.2 TEST INSTRUMENTS

Same as 4.6.2



A D T

4.8.3 TEST PROCEDURES

- a. The power was measured with R&S Spectrum Analyzer. All measurements were done at specific channels.
- b. Substitution method is used for E.I.R.P measurement. In the semi-anechoic chamber, EUT placed on the 0.8m height of Turn Table, rotated the table around 360 degrees to search the maximum radiation power and receiver antenna shall be rotated vertical and horizontal polarization and moved height from 1m to 4m to find the maximum polar radiated power. The “Read Value” is the spectrum reading the maximum power value.
- c. The substitution antenna is substituted for EUT at the same position and signals generator export the CW signal to the substitution antenna via a TX cable. Rotated the Turn Table and moved receiving antenna to find the maximum radiation power. Adjust output power level of S.G to get a Value of spectrum reading equal to “Read Value “ of step b. Record the power level of S.G
- d. $EIRP = \text{Output power level of S.G} - \text{TX cable loss} + \text{Antenna gain of substitution antenna}$.

NOTE: The resolution bandwidth and video bandwidth of test receiver/spectrum analyzer is 1MHz/3MHz

4.8.4 DEVIATION FROM TEST STANDARD

No deviation

4.8.5 TEST SETUP

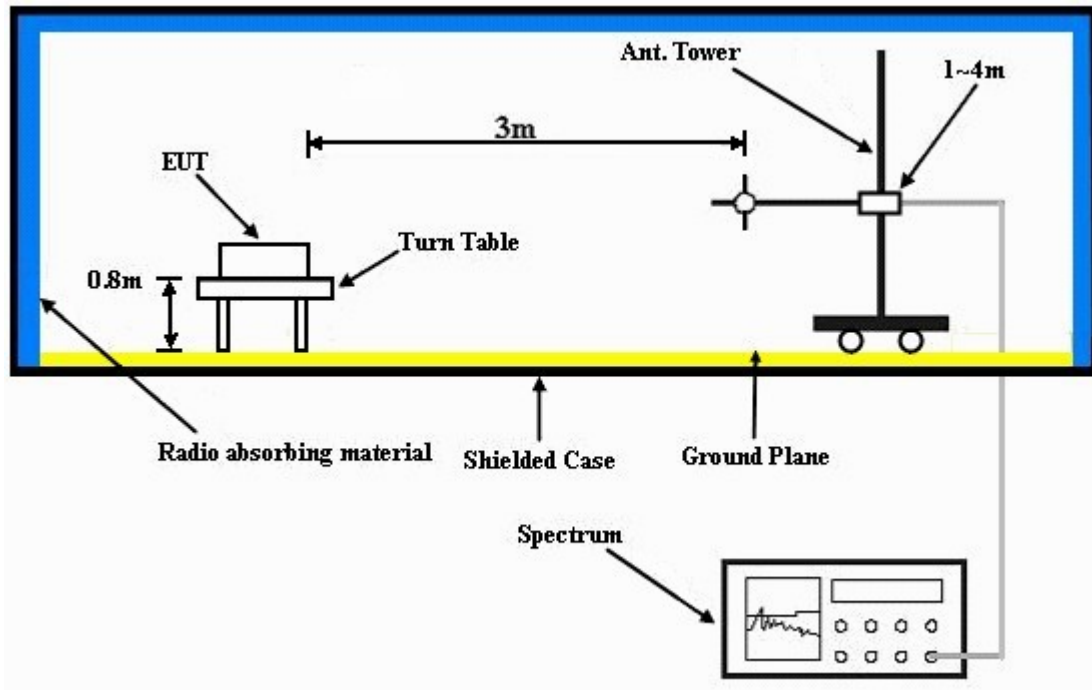

For the actual test configuration, please refer to the related item – Photographs of the Test Configuration.

4.8.6 EUT OPERATING CONDITIONS

Same as 4.6.6.



A D T

4.8.7 TEST RESULTS

CHANNEL BANDWIDTH: 5MHz

ABOVE 1GHz DATA

CHANNEL FREQUENCY: 2307.5MHz						
ANTENNA POLARITY & TEST DISTANCE: HORIZONTAL AT 3 m						
NO.	FREQ. (MHz)	EMISSION LEVEL (dBuV)	LIMIT (dBm)	S.G POWER VALUE (dBm)	CORRECTION FACTOR (dB)	POWER VALUE (dBm)
1	4615.00	38.7	-45.0	-65.8	9.6	-56.2
2	6922.50	45.3	-45.0	-57.5	8.0	-49.5
3	9230.00	48.6	-45.0	-54.3	7.5	-46.8
ANTENNA POLARITY & TEST DISTANCE: VERTICAL AT 3 m						
NO.	FREQ. (MHz)	EMISSION LEVEL (dBuV)	LIMIT (dBm)	S.G POWER VALUE (dBm)	CORRECTION FACTOR (dB)	POWER VALUE (dBm)
1	4615.00	37.9	-45.0	-66.6	9.6	-57.0
2	6922.50	44.8	-45.0	-58.0	8.0	-50.0
3	9230.00	49.2	-45.0	-53.7	7.5	-46.2
CHANNEL FREQUENCY: 2312.5MHz						
ANTENNA POLARITY & TEST DISTANCE: HORIZONTAL AT 3 m						
NO.	FREQ. (MHz)	EMISSION LEVEL (dBuV)	LIMIT (dBm)	S.G POWER VALUE (dBm)	CORRECTION FACTOR (dB)	POWER VALUE (dBm)
1	4625.00	39.0	-45.0	-65.4	9.6	-55.8
2	6937.50	46.8	-45.0	-55.9	8.0	-47.9
3	9250.00	49.0	-45.0	-53.9	7.5	-46.4
ANTENNA POLARITY & TEST DISTANCE: VERTICAL AT 3 m						
NO.	FREQ. (MHz)	EMISSION LEVEL (dBuV)	LIMIT (dBm)	S.G POWER VALUE (dBm)	CORRECTION FACTOR (dB)	POWER VALUE (dBm)
1	4625.00	38.3	-45.0	-66.1	9.6	-56.5
2	6937.50	45.6	-45.0	-57.1	8.0	-49.1
3	9250.00	49.2	-45.0	-53.7	7.5	-46.2

NOTE: Power Value (dBum) = S.G Power Value (dBm) + Correction Factor (dB).



A D T

CHANNEL FREQUENCY: 2352.5MHz						
ANTENNA POLARITY & TEST DISTANCE: HORIZONTAL AT 3 m						
NO.	FREQ. (MHz)	EMISSION LEVEL (dBuV)	LIMIT (dBm)	S.G POWER VALUE (dBm)	CORRECTION FACTOR (dB)	POWER VALUE (dBm)
1	4705.00	39.0	-45.0	-65.3	9.6	-55.7
2	7057.50	46.8	-45.0	-55.9	8.0	-47.9
3	9410.00	48.8	-45.0	-54.2	7.5	-46.7
ANTENNA POLARITY & TEST DISTANCE: VERTICAL AT 3 m						
NO.	FREQ. (MHz)	EMISSION LEVEL (dBuV)	LIMIT (dBm)	S.G POWER VALUE (dBm)	CORRECTION FACTOR (dB)	POWER VALUE (dBm)
1	4705.00	40.2	-45.0	-64.1	9.6	-54.5
2	7057.50	46.3	-45.0	-56.4	8.0	-48.4
3	9410.00	49.1	-45.0	-53.9	7.5	-46.4
CHANNEL FREQUENCY: 2357.5MHz						
ANTENNA POLARITY & TEST DISTANCE: HORIZONTAL AT 3 m						
NO.	FREQ. (MHz)	EMISSION LEVEL (dBuV)	LIMIT (dBm)	S.G POWER VALUE (dBm)	CORRECTION FACTOR (dB)	POWER VALUE (dBm)
1	4715.00	39.3	-45.0	-64.9	9.6	-55.3
2	7072.50	46.7	-45.0	-56.0	8.0	-48.0
3	9430.00	48.8	-45.0	-54.2	7.5	-46.7
ANTENNA POLARITY & TEST DISTANCE: VERTICAL AT 3 m						
NO.	FREQ. (MHz)	EMISSION LEVEL (dBuV)	LIMIT (dBm)	S.G POWER VALUE (dBm)	CORRECTION FACTOR (dB)	POWER VALUE (dBm)
1	4715.00	38.8	-45.0	-65.4	9.6	-55.8
2	7072.50	47.2	-45.0	-55.5	8.0	-47.5
3	9430.00	49.2	-45.0	-53.8	7.5	-46.3

NOTE: Power Value (dBum) = S.G Power Value (dBm) + Correction Factor (dB).



A D T

CHANNEL BANDWIDTH: 10MHz

ABOVE 1GHz DATA

CHANNEL FREQUENCY: 2310MHz						
ANTENNA POLARITY & TEST DISTANCE: HORIZONTAL AT 3 m						
NO.	FREQ. (MHz)	EMISSION LEVEL (dBuV)	LIMIT (dBm)	S.G POWER VALUE (dBm)	CORRECTION FACTOR (dB)	POWER VALUE (dBm)
1	4620.00	39.3	-45.0	-65.1	9.6	-55.5
2	6930.00	46.2	-45.0	-56.5	8.0	-48.5
3	9240.00	48.5	-45.0	-54.4	7.5	-46.9
ANTENNA POLARITY & TEST DISTANCE: VERTICAL AT 3 m						
NO.	FREQ. (MHz)	EMISSION LEVEL (dBuV)	LIMIT (dBm)	S.G POWER VALUE (dBm)	CORRECTION FACTOR (dB)	POWER VALUE (dBm)
1	4620.00	39.4	-45.0	-65.0	9.6	-55.4
2	6930.00	45.2	-45.0	-57.5	8.0	-49.5
3	9240.00	49.1	-45.0	-53.8	7.5	-46.3
CHANNEL FREQUENCY: 2355MHz						
ANTENNA POLARITY & TEST DISTANCE: HORIZONTAL AT 3 m						
NO.	FREQ. (MHz)	EMISSION LEVEL (dBuV)	LIMIT (dBm)	S.G POWER VALUE (dBm)	CORRECTION FACTOR (dB)	POWER VALUE (dBm)
1	4710.00	39.3	-45.0	-65.0	9.6	-55.4
2	7065.00	42.8	-45.0	-59.9	8.0	-51.9
3	9420.00	48.8	-45.0	-54.2	7.5	-46.7
ANTENNA POLARITY & TEST DISTANCE: VERTICAL AT 3 m						
NO.	FREQ. (MHz)	EMISSION LEVEL (dBuV)	LIMIT (dBm)	S.G POWER VALUE (dBm)	CORRECTION FACTOR (dB)	POWER VALUE (dBm)
1	4710.00	37.8	-45.0	-66.5	9.6	-56.9
2	7065.00	42.3	-45.0	-60.4	8.0	-52.4
3	9420.00	47.0	-45.0	-56.0	7.5	-48.5

NOTE: Power Value (dBum) = S.G Power Value (dBm) + Correction Factor (dB).



A D T

5 PHOTOGRAPHS OF THE TEST CONFIGURATION

Please refer to the attached file (Test Setup Photo).



A D T

6 INFORMATION ON THE TESTING LABORATORIES

We, Bureau Veritas Consumer Products Services (H.K.) Ltd., Taoyuan Branch, were founded in 1988 to provide our best service in EMC, Radio, Telecom and Safety consultation. Our laboratories are accredited and approved according to ISO/IEC 17025.

Copies of accreditation certificates of our laboratories obtained from approval agencies can be downloaded from our web site: www.adt.com.tw/index.5.phtml. If you have any comments, please feel free to contact us at the following:

Linko EMC/RF Lab:

Tel: 886-2-26052180

Fax: 886-2-26051924

Hsin Chu EMC/RF Lab:

Tel: 886-3-5935343

Fax: 886-3-5935342

Hwa Ya EMC/RF/Safety/Telecom Lab:

Tel: 886-3-3183232

Fax: 886-3-3185050

Email: service.adt@tw.bureauveritas.com

Web Site: www.adt.com.tw

The address and road map of all our labs can be found in our web site also.

---END---