

APPENDIX A: TEST DATA

Liquid Level Photo

MSL 2450MHz D=150mm



MSL 5800MHz D=155mm

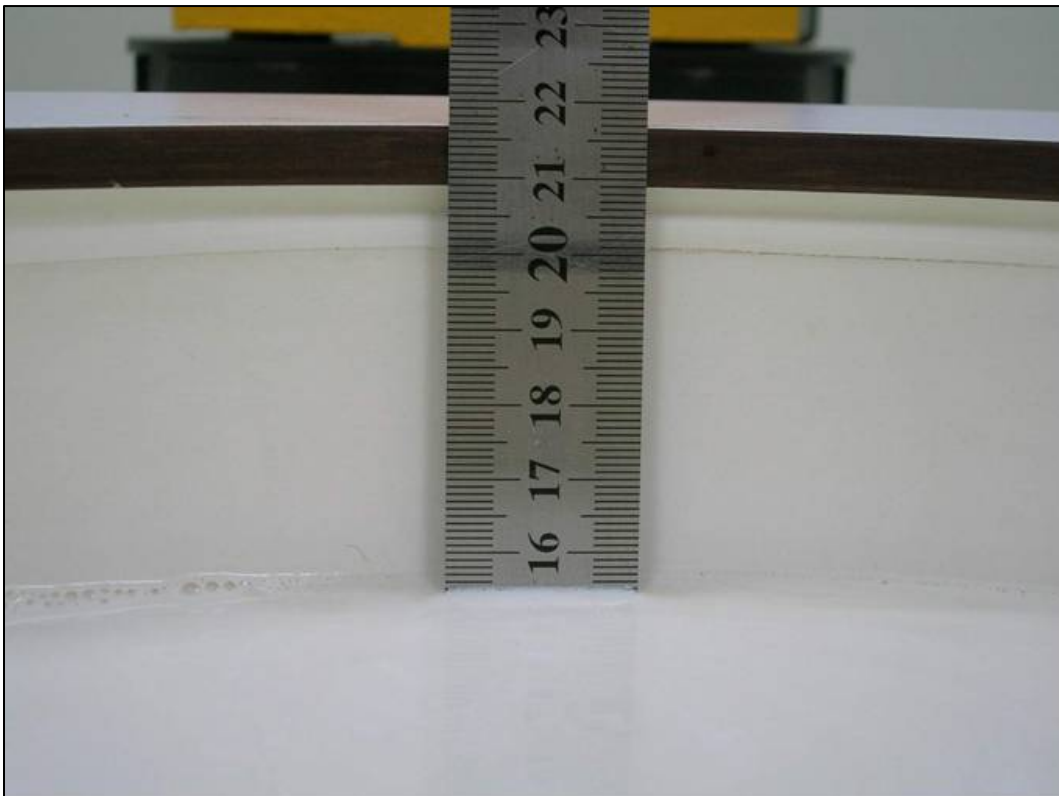

Test Laboratory: Advance Data Technology

M01-11b-Ch1

DUT: Dual Band Wireless N USB Adapter ; Type: AWLL7025

Communication System: 802.11b ; Frequency: 2412 MHz ; Duty Cycle: 1:1 ; Modulation type: DBPSK
 Medium: MSL2450 Medium parameters used: $f = 2412$ MHz; $\sigma = 1.95$ mho/m; $\epsilon_r = 53.6$; $\rho = 1000$ kg/m³
 Phantom section: Flat Section ; Separation distance : 5 mm (The bottom side of the EUT to the Phantom)
 Area scan find secondary maxima within 2dB and with a peak SAR value greater than 0.0012 W/Kg

DASY4 Configuration:

- Probe: EX3DV3 - SN3506 ; ConvF(7.52, 7.52, 7.52) ; Calibrated: 2008/9/30
- Sensor-Surface: 3mm (Mechanical Surface Detection)
- Electronics: DAE3 Sn579 ; Calibrated: 2008/3/13
- Phantom: SAM 12 ; Type: SAM V4.0 ; Serial: TP 1202
- Measurement SW: DASY4, V4.7 Build 53 ; Postprocessing SW: SEMCAD, V1.8 Build 172

Low Channel 1/Area Scan (4x8x1): Measurement grid: dx=15mm, dy=15mm

Maximum value of SAR (measured) = 0.602 mW/g

Low Channel 1/Zoom Scan (7x7x7) (7x7x7)/Cube 0: Measurement grid: dx=5mm, dy=5mm, dz=5mm

Reference Value = 11.4 V/m

Peak SAR (extrapolated) = 1.12 W/kg

SAR(1 g) = **0.484 mW/g**; SAR(10 g) = **0.224 mW/g**

Maximum value of SAR (measured) = 0.529 mW/g

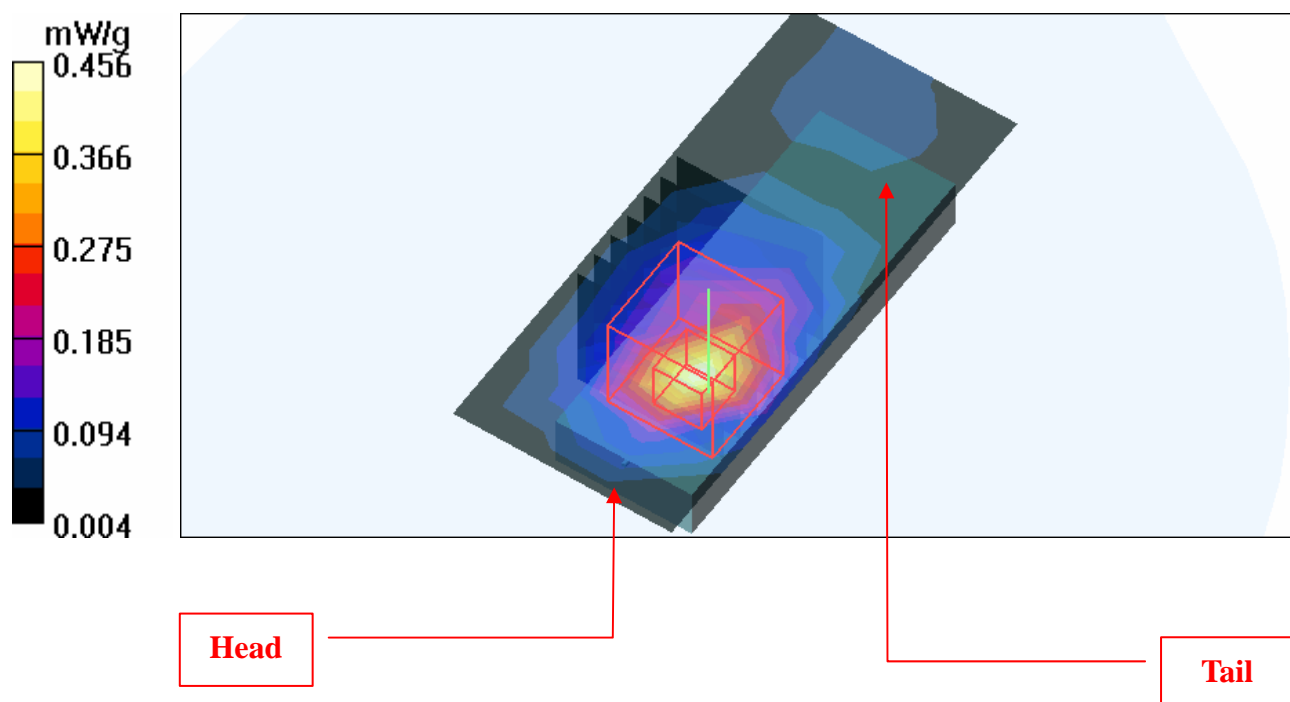

Test Laboratory: Advance Data Technology

M02-11g-Ch6

DUT: Dual Band Wireless N USB Adapter ; Type: AWLL7025

Communication System: 802.11g ; Frequency: 2437 MHz ; Duty Cycle: 1:1 ; Modulation type: BPSK
 Medium: MSL2450 Medium parameters used: $f = 2437$ MHz; $\sigma = 1.98$ mho/m; $\epsilon_r = 53.5$; $\rho = 1000$ kg/m³
 Phantom section: Flat Section ; Separation distance : 5 mm (The bottom side of the EUT to the Phantom)
 Area scan find secondary maxima within 2dB and with a peak SAR value greater than 0.0012 W/Kg

DASY4 Configuration:

- Probe: EX3DV3 - SN3506 ; ConvF(7.52, 7.52, 7.52) ; Calibrated: 2008/9/30
- Sensor-Surface: 3mm (Mechanical Surface Detection)
- Electronics: DAE3 Sn579 ; Calibrated: 2008/3/13
- Phantom: SAM 12 ; Type: SAM V4.0 ; Serial: TP 1202
- Measurement SW: DASY4, V4.7 Build 53 ; Postprocessing SW: SEMCAD, V1.8 Build 172

Mid Channel 6/Area Scan (4x8x1): Measurement grid: dx=15mm, dy=15mm

Maximum value of SAR (measured) = 0.523 mW/g

Mid Channel 6/Zoom Scan (7x7x7) (7x7x7)/Cube 0: Measurement grid: dx=5mm, dy=5mm, dz=5mm

Reference Value = 11.6 V/m

Peak SAR (extrapolated) = 1.31 W/kg

SAR(1 g) = **0.489 mW/g**; SAR(10 g) = **0.216 mW/g**

Maximum value of SAR (measured) = 0.606 mW/g

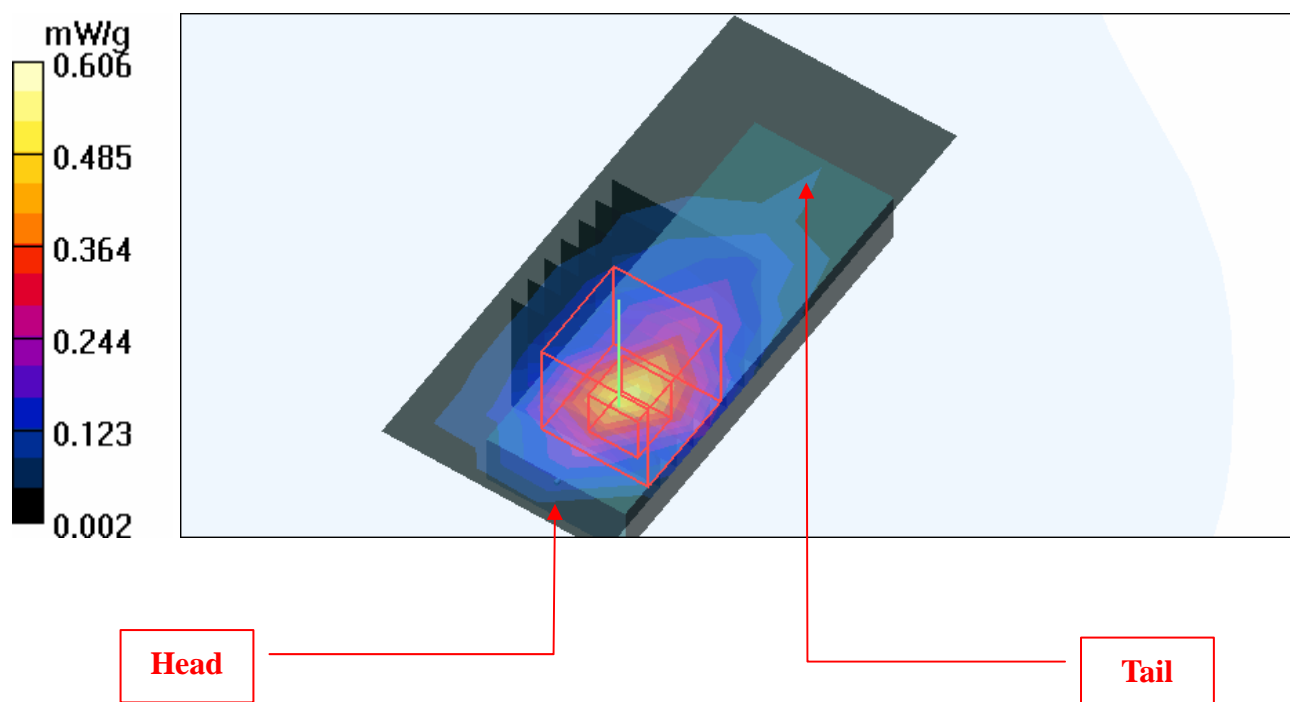

Test Laboratory: Advance Data Technology

M03-11n 20M-Ch6

DUT: Dual Band Wireless N USB Adapter ; Type: AWLL7025

Communication System: 2.4G 11n span20 ; Frequency: 2437 MHz ; Duty Cycle: 1:1 ; Modulation type: BPSK

Medium: MSL2450 Medium parameters used: $f = 2437$ MHz; $\sigma = 1.98$ mho/m; $\epsilon_r = 53.5$; $\rho = 1000$ kg/m³

Phantom section: Flat Section ; Separation distance : 5 mm (The bottom side of the EUT to the Phantom)

Area scan find secondary maxima within 2dB and with a peak SAR value greater than 0.0012 W/Kg

DASY4 Configuration:

- Probe: EX3DV3 - SN3506 ; ConvF(7.52, 7.52, 7.52) ; Calibrated: 2008/9/30
- Sensor-Surface: 3mm (Mechanical Surface Detection)
- Electronics: DAE3 Sn579 ; Calibrated: 2008/3/13
- Phantom: SAM 12 ; Type: SAM V4.0 ; Serial: TP 1202
- Measurement SW: DASY4, V4.7 Build 53 ; Postprocessing SW: SEMCAD, V1.8 Build 172

Mid Channel 6/Area Scan (4x8x1): Measurement grid: dx=15mm, dy=15mm

Maximum value of SAR (measured) = 0.505 mW/g

Mid Channel 6/Zoom Scan (7x7x7) (7x7x7)/Cube 0: Measurement grid: dx=5mm, dy=5mm, dz=5mm

Reference Value = 12.4 V/m

Peak SAR (extrapolated) = 1.32 W/kg

SAR(1 g) = 0.524 mW/g; SAR(10 g) = 0.226 mW/g

Maximum value of SAR (measured) = 0.587 mW/g

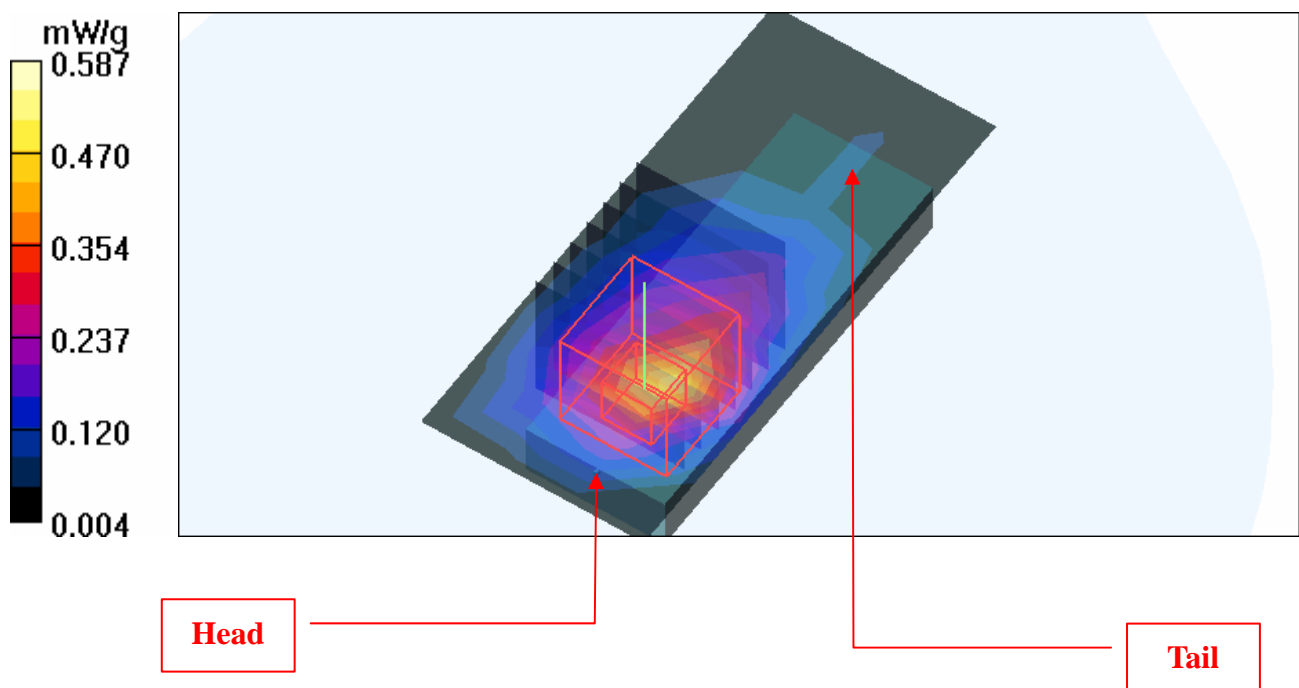

Test Laboratory: Advance Data Technology

M04-11n 40M-Ch4

DUT: Dual Band Wireless N USB Adapter ; Type: AWLL7025

Communication System: 802.11n 40MHz ; Frequency: 2437 MHz ; Duty Cycle: 1:1 ; Modulation type: BPSK

Medium: MSL2450 Medium parameters used: $f = 2437$ MHz; $\sigma = 1.98$ mho/m; $\epsilon_r = 53.5$; $\rho = 1000$ kg/m³

Phantom section: Flat Section ; Separation distance : 5 mm (The bottom side of the EUT to the Phantom)

Area scan find secondary maxima within 2dB and with a peak SAR value greater than 0.0012 W/Kg

DASY4 Configuration:

- Probe: EX3DV3 - SN3506 ; ConvF(7.52, 7.52, 7.52) ; Calibrated: 2008/9/30
- Sensor-Surface: 3mm (Mechanical Surface Detection)
- Electronics: DAE3 Sn579 ; Calibrated: 2008/3/13
- Phantom: SAM 12 ; Type: SAM V4.0 ; Serial: TP 1202
- Measurement SW: DASY4, V4.7 Build 53 ; Postprocessing SW: SEMCAD, V1.8 Build 172

Mid Channel 4/Area Scan (4x8x1): Measurement grid: dx=15mm, dy=15mm

Maximum value of SAR (measured) = 0.300 mW/g

Mid Channel 4/Zoom Scan (7x7x7) (7x7x7)/Cube 0: Measurement grid: dx=5mm, dy=5mm, dz=5mm

Reference Value = 9.42 V/m

Peak SAR (extrapolated) = 0.827 W/kg

SAR(1 g) = 0.288 mW/g; SAR(10 g) = 0.131 mW/g

Maximum value of SAR (measured) = 0.344 mW/g

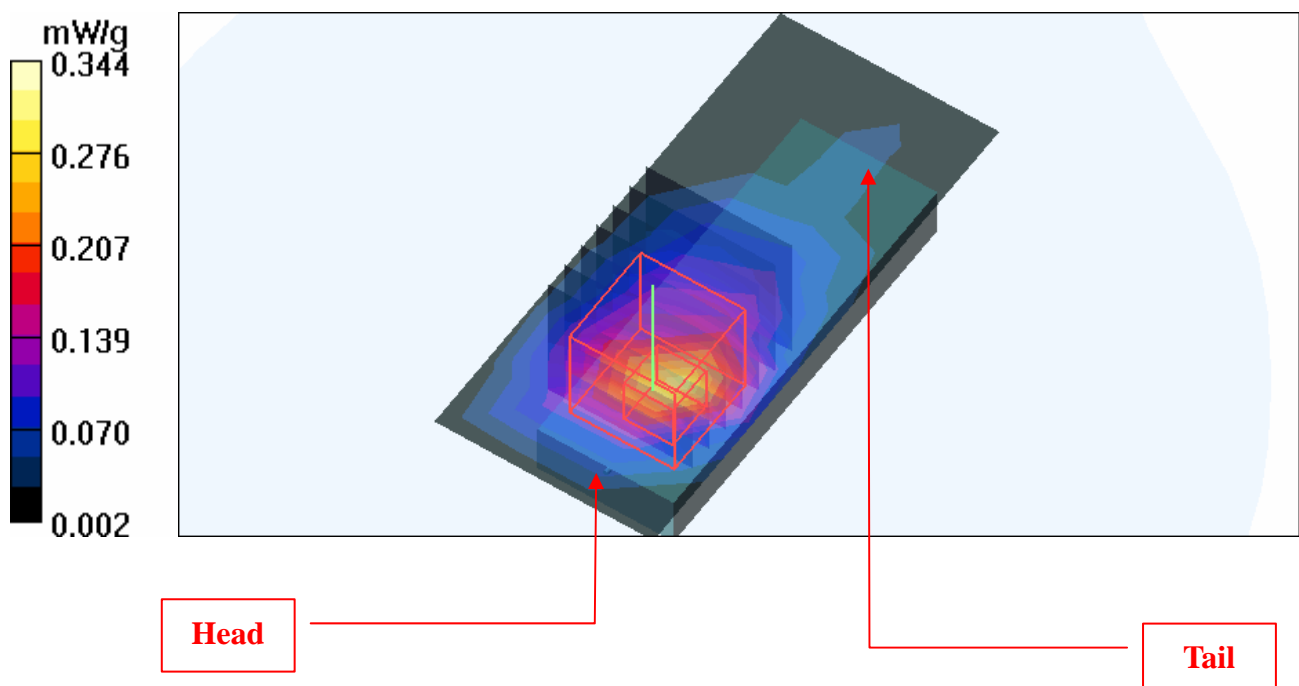

Test Laboratory: Advance Data Technology

M05-11b-Ch1**DUT: Dual Band Wireless N USB Adapter ; Type: AWLL7025**

Communication System: 802.11b ; Frequency: 2412 MHz ; Duty Cycle: 1:1 ; Modulation type: DBPSK
Medium: MSL2450 Medium parameters used: $f = 2412$ MHz; $\sigma = 1.95$ mho/m; $\epsilon_r = 53.6$; $\rho = 1000$ kg/m³
Phantom section: Flat Section ; Separation distance : 5 mm (The edge side of the EUT to the Phantom)
Area scan find secondary maxima within 2dB and with a peak SAR value greater than 0.0012 W/Kg

DASY4 Configuration:

- Probe: EX3DV3 - SN3506 ; ConvF(7.52, 7.52, 7.52) ; Calibrated: 2008/9/30
- Sensor-Surface: 3mm (Mechanical Surface Detection)
- Electronics: DAE3 Sn579 ; Calibrated: 2008/3/13
- Phantom: SAM 12 ; Type: SAM V4.0 ; Serial: TP 1202
- Measurement SW: DASY4, V4.7 Build 53 ; Postprocessing SW: SEMCAD, V1.8 Build 172

Low Channel 1/Area Scan (4x8x1): Measurement grid: dx=15mm, dy=15mm

Maximum value of SAR (measured) = 0.177 mW/g

Low Channel 1/Zoom Scan (7x7x7) (7x7x7)/Cube 0: Measurement grid: dx=5mm, dy=5mm, dz=5mm

Reference Value = 8.73 V/m

Peak SAR (extrapolated) = 0.375 W/kg

SAR(1 g) = 0.183 mW/g; SAR(10 g) = 0.084 mW/g

Maximum value of SAR (measured) = 0.219 mW/g

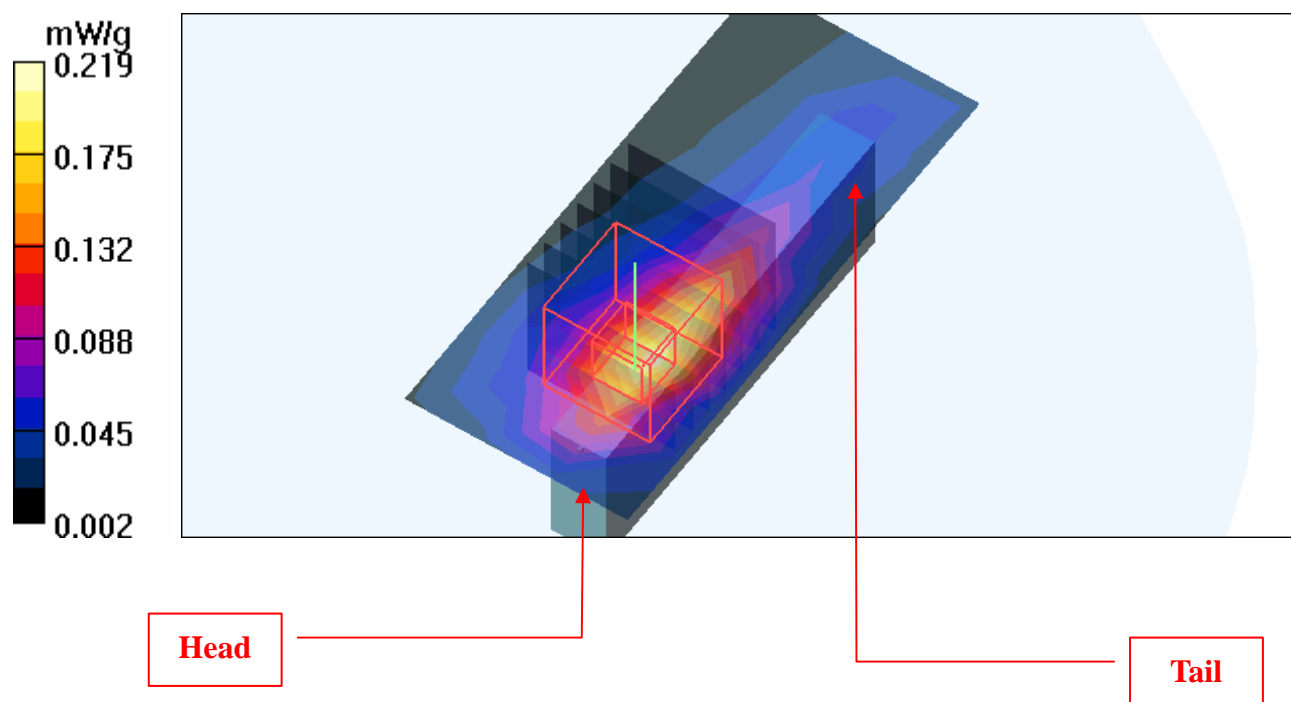

Test Laboratory: Advance Data Technology

M06-11g-Ch6

DUT: Dual Band Wireless N USB Adapter ; Type: AWLL7025

Communication System: 802.11g ; Frequency: 2437 MHz ; Duty Cycle: 1:1 ; Modulation type: BPSK
Medium: MSL2450 Medium parameters used: $f = 2437$ MHz; $\sigma = 1.98$ mho/m; $\epsilon_r = 53.5$; $\rho = 1000$ kg/m³
Phantom section: Flat Section ; Separation distance : 5 mm (The edge side of the EUT to the Phantom)
Area scan find secondary maxima within 2dB and with a peak SAR value greater than 0.0012 W/Kg

DASY4 Configuration:

- Probe: EX3DV3 - SN3506 ; ConvF(7.52, 7.52, 7.52) ; Calibrated: 2008/9/30
- Sensor-Surface: 3mm (Mechanical Surface Detection)
- Electronics: DAE3 Sn579 ; Calibrated: 2008/3/13
- Phantom: SAM 12 ; Type: SAM V4.0 ; Serial: TP 1202
- Measurement SW: DASY4, V4.7 Build 53 ; Postprocessing SW: SEMCAD, V1.8 Build 172

Mid Channel 6/Area Scan (4x8x1): Measurement grid: dx=15mm, dy=15mm

Maximum value of SAR (measured) = 0.134 mW/g

Mid Channel 6/Zoom Scan (7x7x7) (7x7x7)/Cube 0: Measurement grid: dx=5mm, dy=5mm, dz=5mm

Reference Value = 8.06 V/m

Peak SAR (extrapolated) = 0.394 W/kg

SAR(1 g) = 0.174 mW/g; SAR(10 g) = 0.077 mW/g

Maximum value of SAR (measured) = 0.203 mW/g

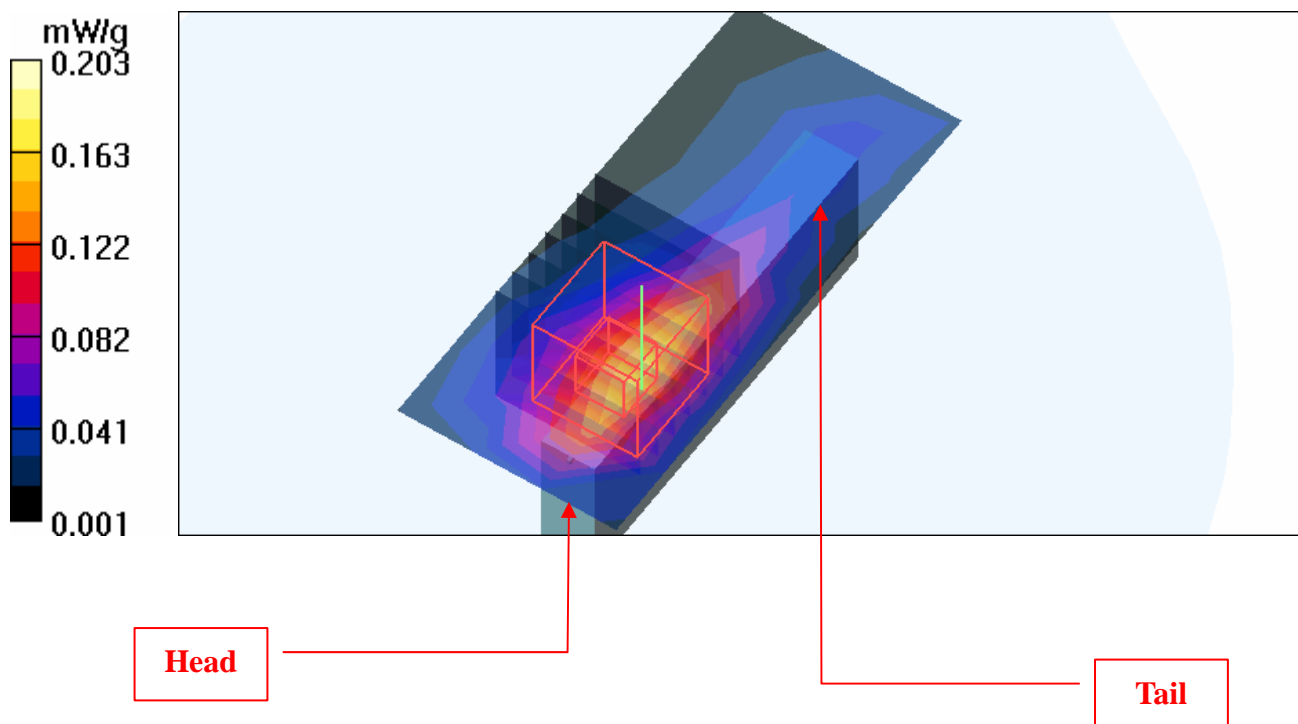

Test Laboratory: Advance Data Technology

M07-11n 20M-Ch6

DUT: Dual Band Wireless N USB Adapter ; Type: AWLL7025

Communication System: 2.4G 11n span20 ; Frequency: 2437 MHz ; Duty Cycle: 1:1 ; Modulation type: BPSK

Medium: MSL2450 Medium parameters used: $f = 2437$ MHz; $\sigma = 1.98$ mho/m; $\epsilon_r = 53.5$; $\rho = 1000$ kg/m³

Phantom section: Flat Section ; Separation distance : 5 mm (The edge side of the EUT to the Phantom)

Area scan find secondary maxima within 2dB and with a peak SAR value greater than 0.0012 W/Kg

DASY4 Configuration:

- Probe: EX3DV3 - SN3506 ; ConvF(7.52, 7.52, 7.52) ; Calibrated: 2008/9/30
- Sensor-Surface: 3mm (Mechanical Surface Detection)
- Electronics: DAE3 Sn579 ; Calibrated: 2008/3/13
- Phantom: SAM 12 ; Type: SAM V4.0 ; Serial: TP 1202
- Measurement SW: DASY4, V4.7 Build 53 ; Postprocessing SW: SEMCAD, V1.8 Build 172

Mid Channel 6/Area Scan (4x8x1): Measurement grid: dx=15mm, dy=15mm

Maximum value of SAR (measured) = 0.177 mW/g

Mid Channel 6/Zoom Scan (7x7x7) (7x7x7)/Cube 0: Measurement grid: dx=5mm, dy=5mm, dz=5mm

Reference Value = 8.31 V/m

Peak SAR (extrapolated) = 0.448 W/kg

SAR(1 g) = 0.170 mW/g; SAR(10 g) = 0.078 mW/g

Maximum value of SAR (measured) = 0.192 mW/g

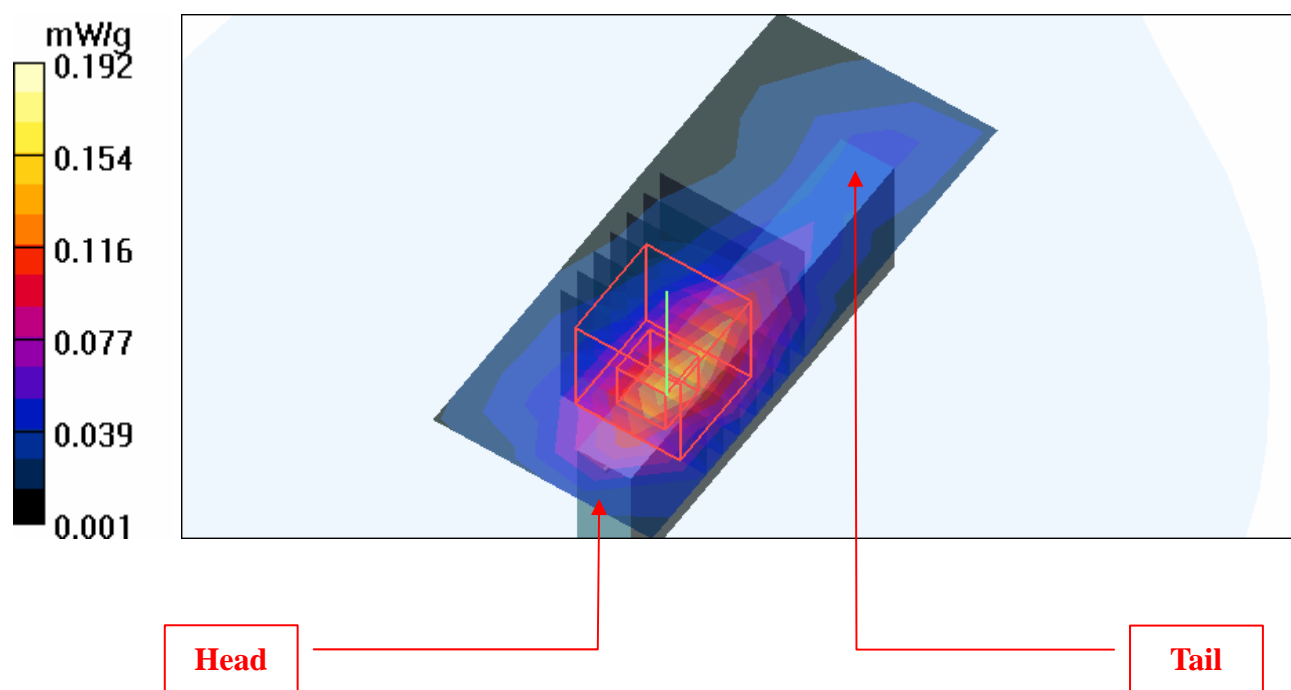

Test Laboratory: Advance Data Technology

M08--11n 40M-Ch4**DUT: Dual Band Wireless N USB Adapter ; Type: AWLL7025**

Communication System: 802.11n 40MHz ; Frequency: 2437 MHz ; Duty Cycle: 1:1 ; Modulation type: BPSK

Medium: MSL2450 Medium parameters used: $f = 2437$ MHz; $\sigma = 1.98$ mho/m; $\epsilon_r = 53.5$; $\rho = 1000$ kg/m³

Phantom section: Flat Section ; Separation distance : 5 mm (The edge side of the EUT to the Phantom)

Area scan find secondary maxima within 2dB and with a peak SAR value greater than 0.0012 W/Kg

DASY4 Configuration:

- Probe: EX3DV3 - SN3506 ; ConvF(7.52, 7.52, 7.52) ; Calibrated: 2008/9/30
- Sensor-Surface: 3mm (Mechanical Surface Detection)
- Electronics: DAE3 Sn579 ; Calibrated: 2008/3/13
- Phantom: SAM 12 ; Type: SAM V4.0 ; Serial: TP 1202
- Measurement SW: DASY4, V4.7 Build 53 ; Postprocessing SW: SEMCAD, V1.8 Build 172

Mid Channel 4/Area Scan (4x8x1): Measurement grid: dx=15mm, dy=15mm

Maximum value of SAR (measured) = 0.066 mW/g

Mid Channel 4/Zoom Scan (7x7x7) (7x7x7)/Cube 0: Measurement grid: dx=5mm, dy=5mm, dz=5mm

Reference Value = 4.84 V/m

Peak SAR (extrapolated) = 0.126 W/kg

SAR(1 g) = 0.063 mW/g; SAR(10 g) = 0.029 mW/g

Maximum value of SAR (measured) = 0.072 mW/g

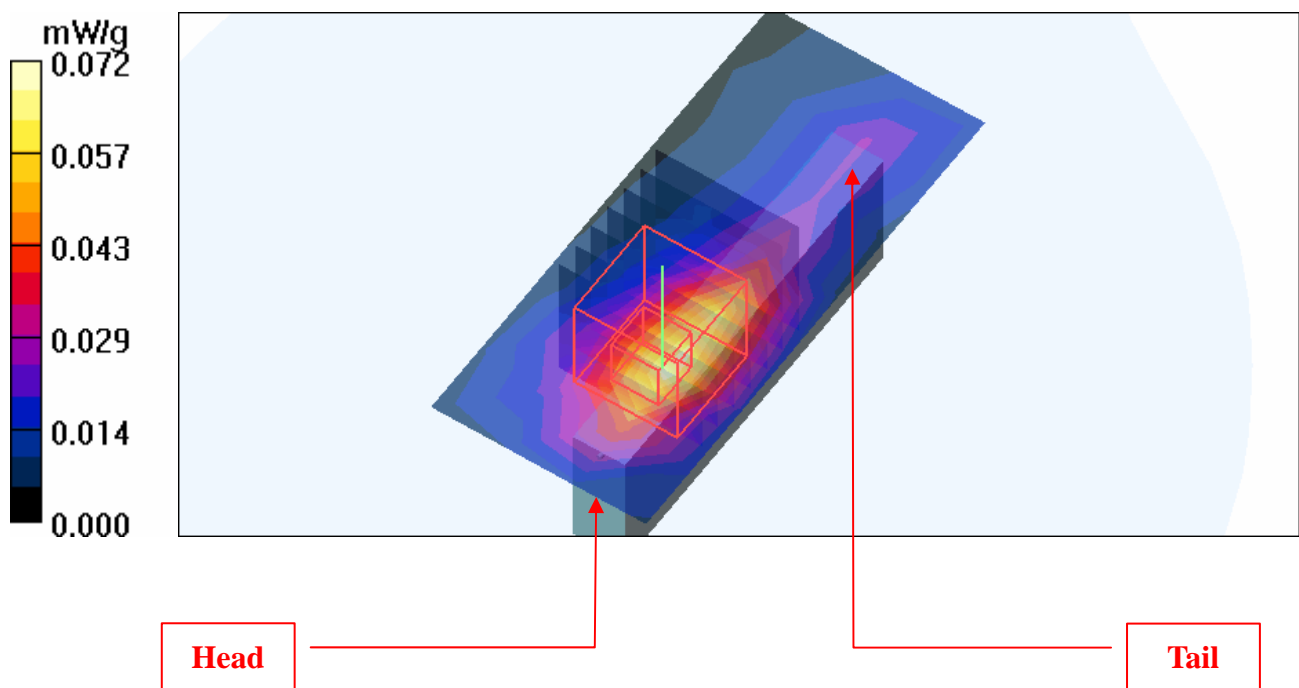

Test Laboratory: Advance Data Technology

M09-11b-Ch6

DUT: Dual Band Wireless N USB Adapter ; Type: AWLL7025

Communication System: 802.11b ; Frequency: 2412 MHz ; Duty Cycle: 1:1 ; Modulation type: DBPSK
 Medium: MSL2450 Medium parameters used: $f = 2412$ MHz; $\sigma = 1.95$ mho/m; $\epsilon_r = 53.6$; $\rho = 1000$ kg/m³
 Phantom section: Flat Section ; Separation distance : 5 mm (The front side of the EUT to the Phantom)
 Area scan find secondary maxima within 2dB and with a peak SAR value greater than 0.0012 W/Kg

DASY4 Configuration:

- Probe: EX3DV3 - SN3506 ; ConvF(7.52, 7.52, 7.52) ; Calibrated: 2008/9/30
- Sensor-Surface: 3mm (Mechanical Surface Detection)
- Electronics: DAE3 Sn579 ; Calibrated: 2008/3/13
- Phantom: SAM 12 ; Type: SAM V4.0 ; Serial: TP 1202
- Measurement SW: DASY4, V4.7 Build 53 ; Postprocessing SW: SEMCAD, V1.8 Build 172

Low Channel 1/Area Scan (4x8x1): Measurement grid: dx=15mm, dy=15mm

Maximum value of SAR (measured) = 0.235 mW/g

Low Channel 1/Zoom Scan (7x7x7) (7x7x7)/Cube 0: Measurement grid: dx=5mm, dy=5mm, dz=5mm

Reference Value = 9.16 V/m

Peak SAR (extrapolated) = 0.691 W/kg

SAR(1 g) = **0.282 mW/g**; SAR(10 g) = **0.124 mW/g**

Maximum value of SAR (measured) = 0.312 mW/g

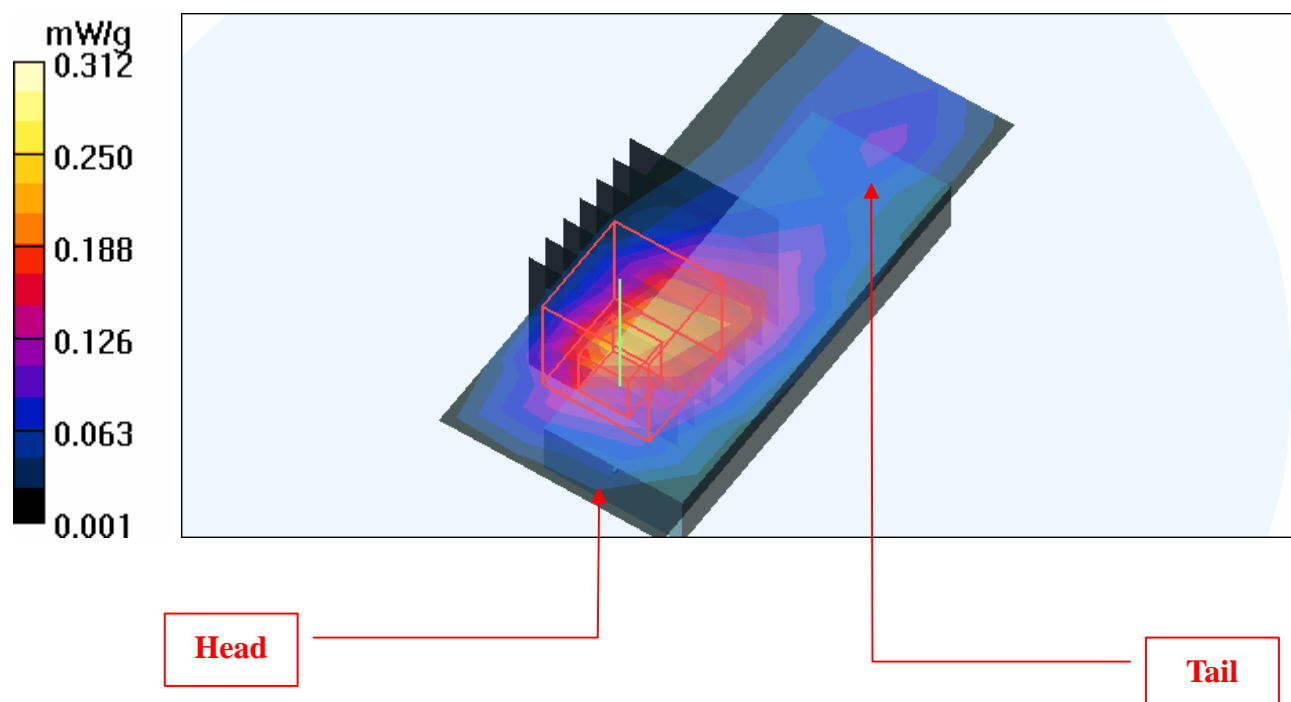

Test Laboratory: Advance Data Technology

M10-11g-Ch6

DUT: Dual Band Wireless N USB Adapter ; Type: AWLL7025

Communication System: 802.11g ; Frequency: 2437 MHz ; Duty Cycle: 1:1 ; Modulation type: BPSK
 Medium: MSL2450 Medium parameters used: $f = 2437$ MHz; $\sigma = 1.98$ mho/m; $\epsilon_r = 53.5$; $\rho = 1000$ kg/m³
 Phantom section: Flat Section ; Separation distance : 5 mm (The front side of the EUT to the Phantom)
 Area scan find secondary maxima within 2dB and with a peak SAR value greater than 0.0012 W/Kg

DASY4 Configuration:

- Probe: EX3DV3 - SN3506 ; ConvF(7.52, 7.52, 7.52) ; Calibrated: 2008/9/30
- Sensor-Surface: 3mm (Mechanical Surface Detection)
- Electronics: DAE3 Sn579 ; Calibrated: 2008/3/13
- Phantom: SAM 12 ; Type: SAM V4.0 ; Serial: TP 1202
- Measurement SW: DASY4, V4.7 Build 53 ; Postprocessing SW: SEMCAD, V1.8 Build 172

Mid Channel 6/Area Scan (4x8x1): Measurement grid: dx=15mm, dy=15mm

Maximum value of SAR (measured) = 0.316 mW/g

Mid Channel 6/Zoom Scan (7x7x7) (7x7x7)/Cube 0: Measurement grid: dx=5mm, dy=5mm, dz=5mm

Reference Value = 9.62 V/m

Peak SAR (extrapolated) = 0.738 W/kg

SAR(1 g) = **0.317 mW/g**; SAR(10 g) = **0.138 mW/g**

Maximum value of SAR (measured) = 0.386 mW/g

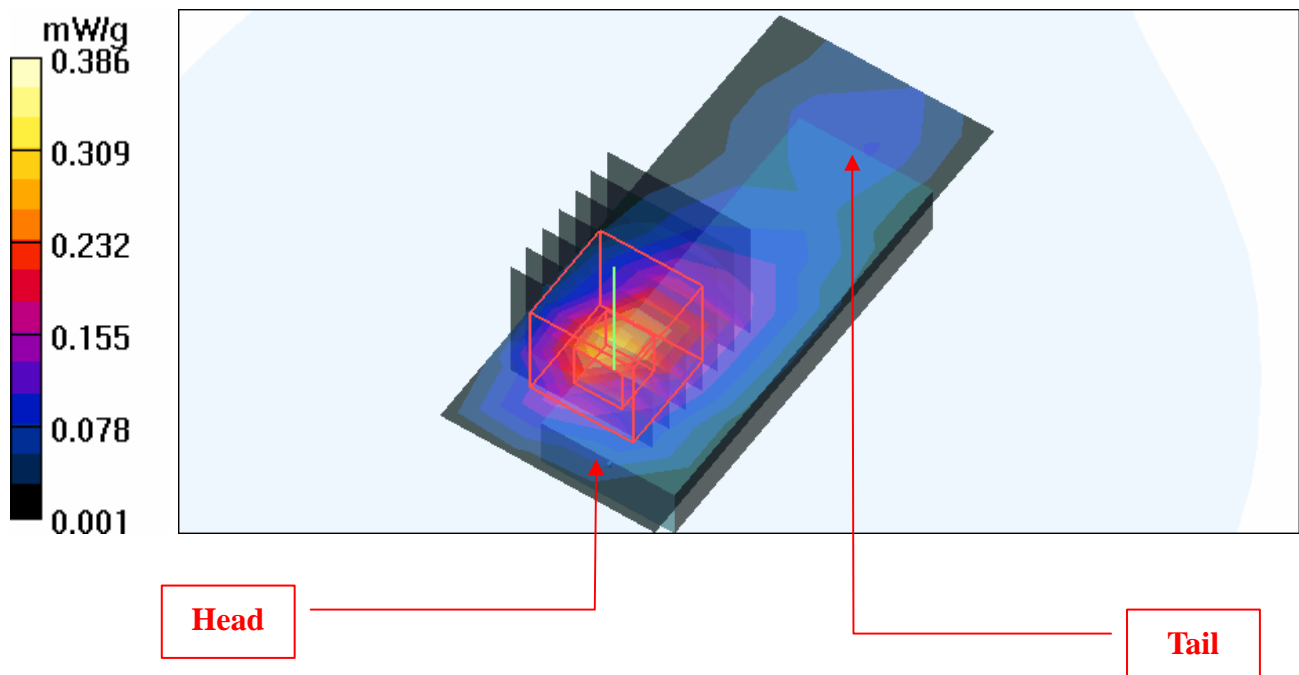

Test Laboratory: Advance Data Technology

M11-11n 20M-Ch6

DUT: Dual Band Wireless N USB Adapter ; Type: AWLL7025

Communication System: 2.4G 11n span20 ; Frequency: 2437 MHz ; Duty Cycle: 1:1 ; Modulation type: BPSK

Medium: MSL2450 Medium parameters used: $f = 2437$ MHz; $\sigma = 1.98$ mho/m; $\epsilon_r = 53.5$; $\rho = 1000$ kg/m³

Phantom section: Flat Section ; Separation distance : 5 mm (The front side of the EUT to the Phantom)

Area scan find secondary maxima within 2dB and with a peak SAR value greater than 0.0012 W/Kg

DASY4 Configuration:

- Probe: EX3DV3 - SN3506 ; ConvF(7.52, 7.52, 7.52) ; Calibrated: 2008/9/30
- Sensor-Surface: 3mm (Mechanical Surface Detection)
- Electronics: DAE3 Sn579 ; Calibrated: 2008/3/13
- Phantom: SAM 12 ; Type: SAM V4.0 ; Serial: TP 1202
- Measurement SW: DASY4, V4.7 Build 53 ; Postprocessing SW: SEMCAD, V1.8 Build 172

Mid Channel 6/Area Scan (4x8x1): Measurement grid: dx=15mm, dy=15mm

Maximum value of SAR (measured) = 0.287 mW/g

Mid Channel 6/Zoom Scan (7x7x7) (7x7x7)/Cube 0: Measurement grid: dx=5mm, dy=5mm, dz=5mm

Reference Value = 10.5 V/m

Peak SAR (extrapolated) = 0.943 W/kg

SAR(1 g) = 0.350 mW/g; SAR(10 g) = 0.154 mW/g

Maximum value of SAR (measured) = 0.391 mW/g

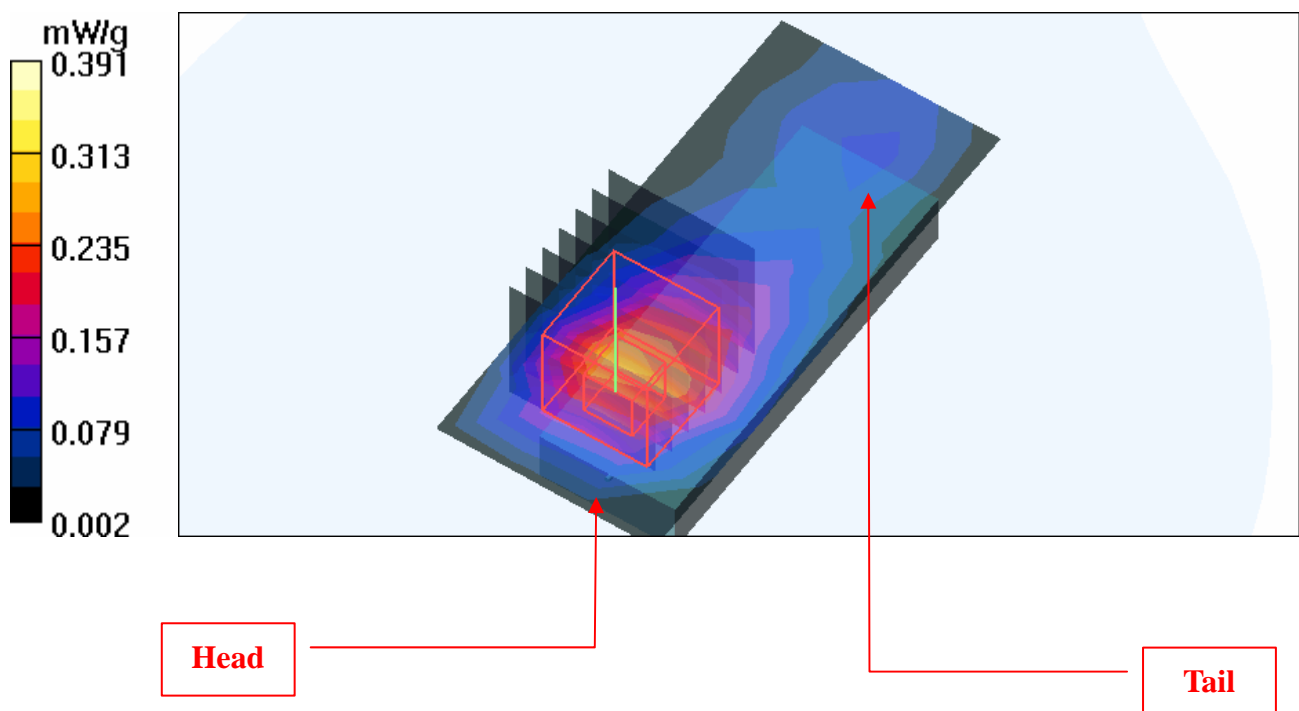

Test Laboratory: Advance Data Technology

M12-11n 40M-Ch4

DUT: Dual Band Wireless N USB Adapter ; Type: AWLL7025

Communication System: 802.11n 40MHz ; Frequency: 2437 MHz ; Duty Cycle: 1:1 ; Modulation type: BPSK

Medium: MSL2450 Medium parameters used: $f = 2437$ MHz; $\sigma = 1.98$ mho/m; $\epsilon_r = 53.5$; $\rho = 1000$ kg/m³

Phantom section: Flat Section ; Separation distance : 5 mm (The front side of the EUT to the Phantom)

Area scan find secondary maxima within 2dB and with a peak SAR value greater than 0.0012 W/Kg

DASY4 Configuration:

- Probe: EX3DV3 - SN3506 ; ConvF(7.52, 7.52, 7.52) ; Calibrated: 2008/9/30
- Sensor-Surface: 3mm (Mechanical Surface Detection)
- Electronics: DAE3 Sn579 ; Calibrated: 2008/3/13
- Phantom: SAM 12 ; Type: SAM V4.0 ; Serial: TP 1202
- Measurement SW: DASY4, V4.7 Build 53 ; Postprocessing SW: SEMCAD, V1.8 Build 172

Mid Channel 4/Area Scan (4x8x1): Measurement grid: dx=15mm, dy=15mm

Maximum value of SAR (measured) = 0.111 mW/g

Mid Channel 4/Zoom Scan (7x7x7) (7x7x7)/Cube 0: Measurement grid: dx=5mm, dy=5mm, dz=5mm

Reference Value = 6.73 V/m

Peak SAR (extrapolated) = 0.371 W/kg

SAR(1 g) = 0.148 mW/g; SAR(10 g) = 0.066 mW/g

Maximum value of SAR (measured) = 0.162 mW/g

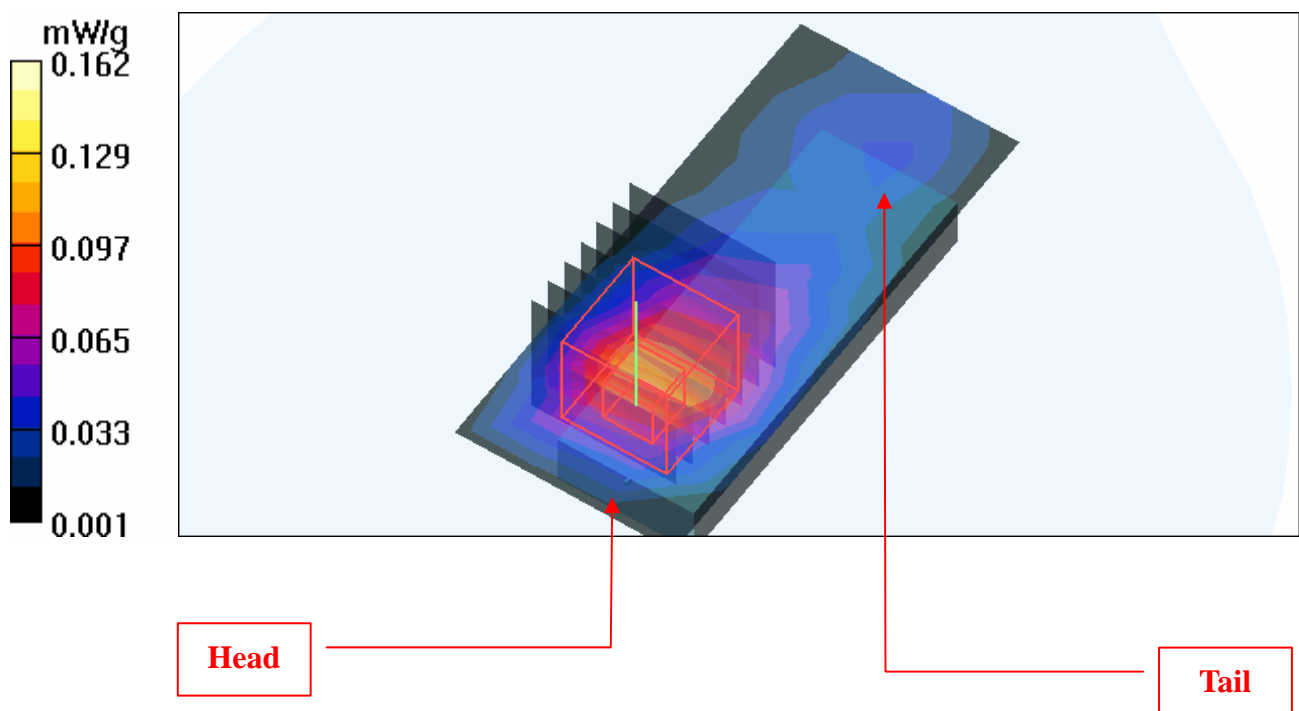

Test Laboratory: Advance Data Technology

M13-11b-Ch6

DUT: Dual Band Wireless N USB Adapter ; Type: AWLL7025

Communication System: 802.11b ; Frequency: 2412 MHz ; Duty Cycle: 1:1 ; Modulation type: DBPSK
 Medium: MSL2450 Medium parameters used: $f = 2412$ MHz; $\sigma = 1.95$ mho/m; $\epsilon_r = 53.6$; $\rho = 1000$ kg/m³
 Phantom section: Flat Section ; Separation distance : 5 mm (The edge side of the EUT to the Phantom)
 Area scan find secondary maxima within 2dB and with a peak SAR value greater than 0.0012 W/Kg

DASY4 Configuration:

- Probe: EX3DV3 - SN3506 ; ConvF(7.52, 7.52, 7.52) ; Calibrated: 2008/9/30
- Sensor-Surface: 3mm (Mechanical Surface Detection)
- Electronics: DAE3 Sn579 ; Calibrated: 2008/3/13
- Phantom: SAM 12 ; Type: SAM V4.0 ; Serial: TP 1202
- Measurement SW: DASY4, V4.7 Build 53 ; Postprocessing SW: SEMCAD, V1.8 Build 172

Low Channel 1/Area Scan (4x8x1): Measurement grid: dx=15mm, dy=15mm

Maximum value of SAR (measured) = 0.109 mW/g

Low Channel 1/Zoom Scan (7x7x7) (7x7x7)/Cube 0: Measurement grid: dx=5mm, dy=5mm, dz=5mm

Reference Value = 2.28 V/m

Peak SAR (extrapolated) = 0.223 W/kg

SAR(1 g) = **0.106 mW/g**; SAR(10 g) = **0.055 mW/g**

Maximum value of SAR (measured) = 0.115 mW/g

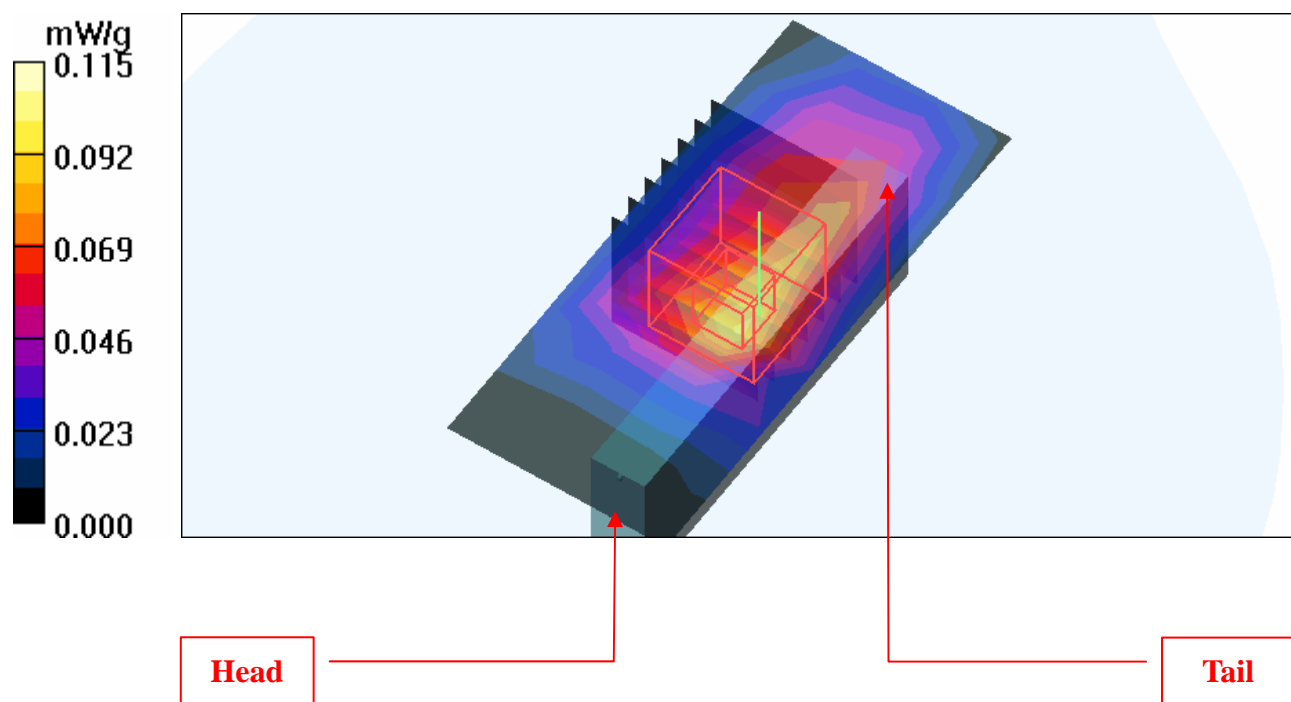

Test Laboratory: Advance Data Technology

M14-11g-Ch6

DUT: Dual Band Wireless N USB Adapter ; Type: AWLL7025

Communication System: 802.11g ; Frequency: 2437 MHz ; Duty Cycle: 1:1 ; Modulation type: BPSK
 Medium: MSL2450 Medium parameters used: $f = 2437$ MHz; $\sigma = 1.98$ mho/m; $\epsilon_r = 53.5$; $\rho = 1000$ kg/m³
 Phantom section: Flat Section ; Separation distance : 5 mm (The edge side of the EUT to the Phantom)
 Area scan find secondary maxima within 2dB and with a peak SAR value greater than 0.0012 W/Kg

DASY4 Configuration:

- Probe: EX3DV3 - SN3506 ; ConvF(7.52, 7.52, 7.52) ; Calibrated: 2008/9/30
- Sensor-Surface: 3mm (Mechanical Surface Detection)
- Electronics: DAE3 Sn579 ; Calibrated: 2008/3/13
- Phantom: SAM 12 ; Type: SAM V4.0 ; Serial: TP 1202
- Measurement SW: DASY4, V4.7 Build 53 ; Postprocessing SW: SEMCAD, V1.8 Build 172

Mid Channel 6/Area Scan (4x8x1): Measurement grid: dx=15mm, dy=15mm

Maximum value of SAR (measured) = 0.107 mW/g

Mid Channel 6/Zoom Scan (7x7x7) (7x7x7)/Cube 0: Measurement grid: dx=5mm, dy=5mm, dz=5mm

Reference Value = 2.62 V/m

Peak SAR (extrapolated) = 0.326 W/kg

SAR(1 g) = **0.110 mW/g**; SAR(10 g) = **0.055 mW/g**

Maximum value of SAR (measured) = 0.112 mW/g

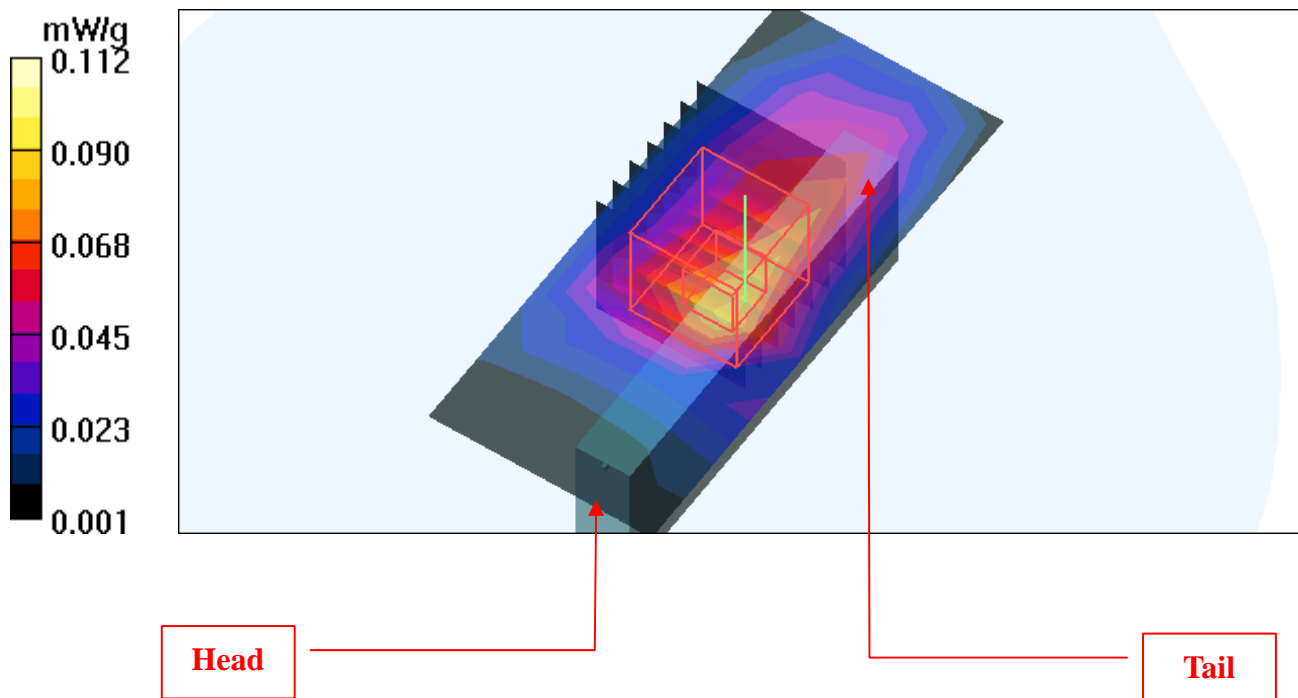

Test Laboratory: Advance Data Technology

M15-11n 20M-Ch6

DUT: Dual Band Wireless N USB Adapter ; Type: AWLL7025

Communication System: 2.4G 11n span20 ; Frequency: 2437 MHz ; Duty Cycle: 1:1 ; Modulation type: BPSK

Medium: MSL2450 Medium parameters used: $f = 2437$ MHz; $\sigma = 1.98$ mho/m; $\epsilon_r = 53.5$; $\rho = 1000$ kg/m³

Phantom section: Flat Section ; Separation distance : 5 mm (The edge side of the EUT to the Phantom)

Area scan find secondary maxima within 2dB and with a peak SAR value greater than 0.0012 W/Kg

DASY4 Configuration:

- Probe: EX3DV3 - SN3506 ; ConvF(7.52, 7.52, 7.52) ; Calibrated: 2008/9/30
- Sensor-Surface: 3mm (Mechanical Surface Detection)
- Electronics: DAE3 Sn579 ; Calibrated: 2008/3/13
- Phantom: SAM 12 ; Type: SAM V4.0 ; Serial: TP 1202
- Measurement SW: DASY4, V4.7 Build 53 ; Postprocessing SW: SEMCAD, V1.8 Build 172

Mid Channel 6/Area Scan (4x8x1): Measurement grid: dx=15mm, dy=15mm

Maximum value of SAR (measured) = 0.137 mW/g

Mid Channel 6/Zoom Scan (7x7x7) (7x7x7)/Cube 0: Measurement grid: dx=5mm, dy=5mm, dz=5mm

Reference Value = 4.62 V/m

Peak SAR (extrapolated) = 0.283 W/kg

SAR(1 g) = 0.133 mW/g; SAR(10 g) = 0.065 mW/g

Maximum value of SAR (measured) = 0.147 mW/g

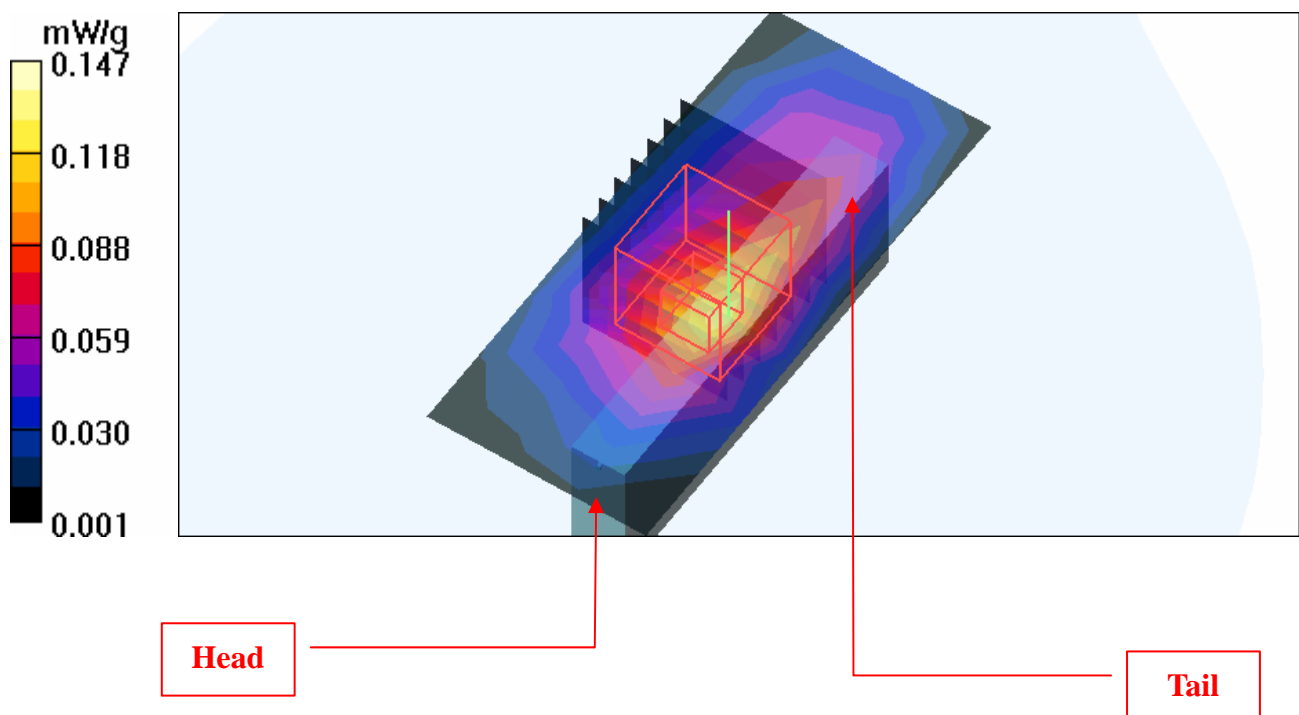

Test Laboratory: Advance Data Technology

M16-11n 40M-Ch4

DUT: Dual Band Wireless N USB Adapter ; Type: AWLL7025

Communication System: 802.11n 40MHz ; Frequency: 2437 MHz ; Duty Cycle: 1:1 ; Modulation type: BPSK

Medium: MSL2450 Medium parameters used: $f = 2437$ MHz; $\sigma = 1.98$ mho/m; $\epsilon_r = 53.5$; $\rho = 1000$ kg/m³

Phantom section: Flat Section ; Separation distance : 5 mm (The edge side of the EUT to the Phantom)

Area scan find secondary maxima within 2dB and with a peak SAR value greater than 0.0012 W/Kg

DASY4 Configuration:

- Probe: EX3DV3 - SN3506 ; ConvF(7.52, 7.52, 7.52) ; Calibrated: 2008/9/30
- Sensor-Surface: 3mm (Mechanical Surface Detection)
- Electronics: DAE3 Sn579 ; Calibrated: 2008/3/13
- Phantom: SAM 12 ; Type: SAM V4.0 ; Serial: TP 1202
- Measurement SW: DASY4, V4.7 Build 53 ; Postprocessing SW: SEMCAD, V1.8 Build 172

Mid Channel 4/Area Scan (4x8x1): Measurement grid: dx=15mm, dy=15mm

Maximum value of SAR (measured) = 0.048 mW/g

Mid Channel 4/Zoom Scan (7x7x7) (7x7x7)/Cube 0: Measurement grid: dx=5mm, dy=5mm, dz=5mm

Reference Value = 3.58 V/m

Peak SAR (extrapolated) = 0.086 W/kg

SAR(1 g) = 0.044 mW/g; SAR(10 g) = 0.023 mW/g

Maximum value of SAR (measured) = 0.055 mW/g

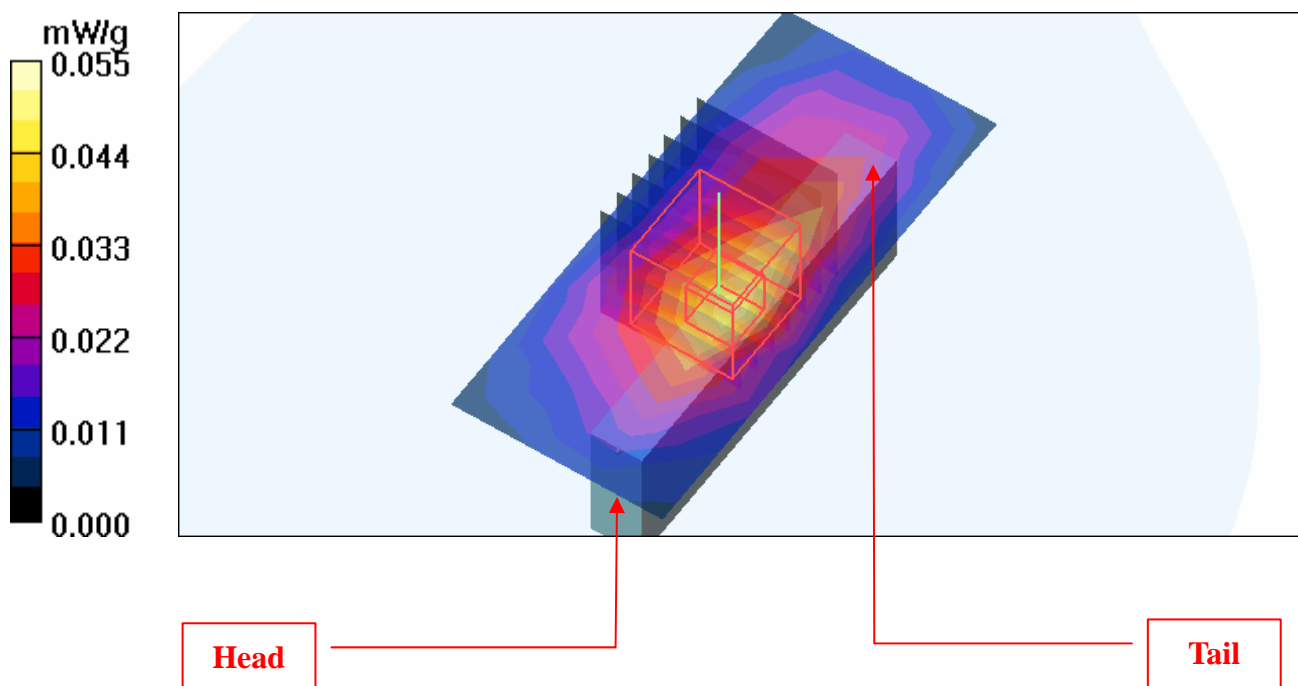

Test Laboratory: Advance Data Technology

M17-11a-Ch149

DUT: Dual Band Wireless N USB Adapter ; Type: AWLL7025

Communication System: 802.11a ; Frequency: 5745 MHz ; Duty Cycle: 1:1 ; Modulation type: BPSK
 Medium: MSL5800 Medium parameters used: $f = 5745$ MHz; $\sigma = 6.16$ mho/m; $\epsilon_r = 48.3$; $\rho = 1000$ kg/m³
 Phantom section: Flat Section ; Separation distance : 5 mm (The bottom side of the EUT to the Phantom)
 Area scan find secondary maxima within 2dB and with a peak SAR value greater than 0.0012 W/Kg

DASY4 Configuration:

- Probe: EX3DV3 - SN3506 ; ConvF(3.87, 3.87, 3.87) ; Calibrated: 2008/9/30
- Sensor-Surface: 3mm (Mechanical Surface Detection)
- Electronics: DAE3 Sn579 ; Calibrated: 2008/3/13
- Phantom: SAM 12 ; Type: SAM V4.0 ; Serial: TP 1202
- Measurement SW: DASY4, V4.7 Build 53 ; Postprocessing SW: SEMCAD, V1.8 Build 172

Low Channel 149/Area Scan (6x10x1): Measurement grid: dx=10mm, dy=10mm
 Maximum value of SAR (measured) = 0.617 mW/g

Low Channel 149/Zoom Scan (8x8x8)/Cube 0: Measurement grid: dx=4.3mm, dy=4.3mm, dz=3mm

Reference Value = 7.25 V/m

Peak SAR (extrapolated) = 2.63 W/kg

SAR(1 g) = 0.500 mW/g; SAR(10 g) = 0.143 mW/g

Maximum value of SAR (measured) = 0.699 mW/g

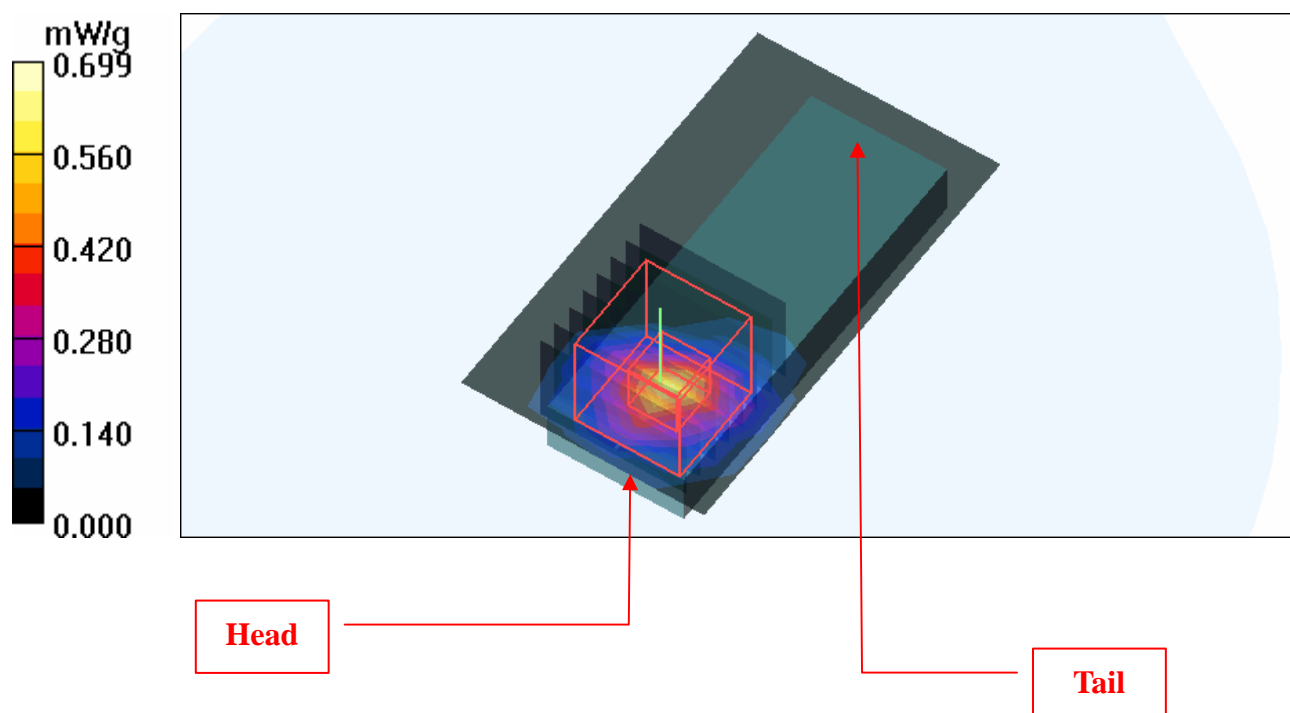

Test Laboratory: Advance Data Technology

M18-11an 20M-Ch165

DUT: Dual Band Wireless N USB Adapter ; Type: AWLL7025

Communication System: 11n 5G span20 ; Frequency: 5825 MHz ; Duty Cycle: 1:1 ; Modulation type: BPSK

Medium: MSL5800 Medium parameters used: $f = 5825$ MHz; $\sigma = 6.29$ mho/m; $\epsilon_r = 48.2$; $\rho = 1000$ kg/m³

Phantom section: Flat Section ; Separation distance : 5 mm (The bottom side of the EUT to the Phantom)

Area scan find secondary maxima within 2dB and with a peak SAR value greater than 0.0012 W/Kg

DASY4 Configuration:

- Probe: EX3DV3 - SN3506 ; ConvF(3.87, 3.87, 3.87) ; Calibrated: 2008/9/30
- Sensor-Surface: 3mm (Mechanical Surface Detection)
- Electronics: DAE3 Sn579 ; Calibrated: 2008/3/13
- Phantom: SAM 12 ; Type: SAM V4.0 ; Serial: TP 1202
- Measurement SW: DASY4, V4.7 Build 53 ; Postprocessing SW: SEMCAD, V1.8 Build 172

High Channel 165/Area Scan (6x10x1): Measurement grid: dx=10mm, dy=10mm

Maximum value of SAR (measured) = 1.08 mW/g

High Channel 165/Zoom Scan (8x8x8)/Cube 0: Measurement grid: dx=4.3mm, dy=4.3mm, dz=3mm

Reference Value = 6.01 V/m

Peak SAR (extrapolated) = 3.19 W/kg

SAR(1 g) = **0.744 mW/g**; SAR(10 g) = 0.251 mW/g

Maximum value of SAR (measured) = 1.12 mW/g

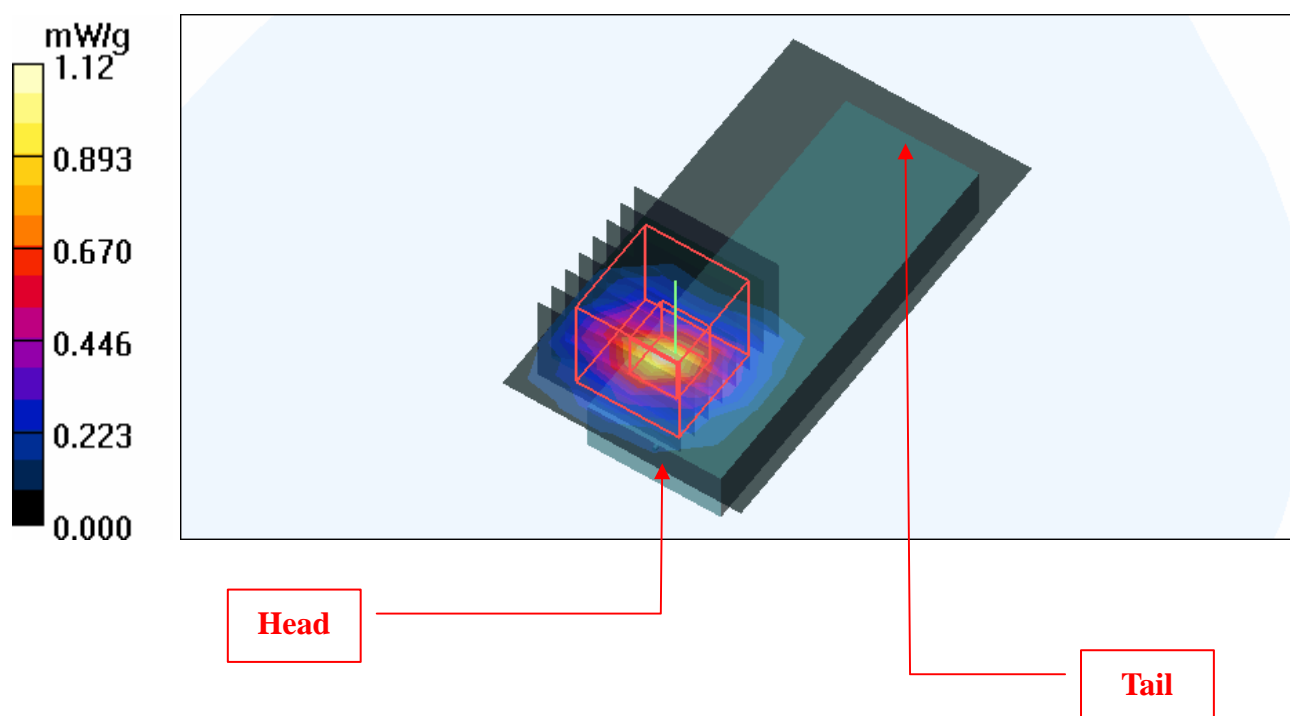

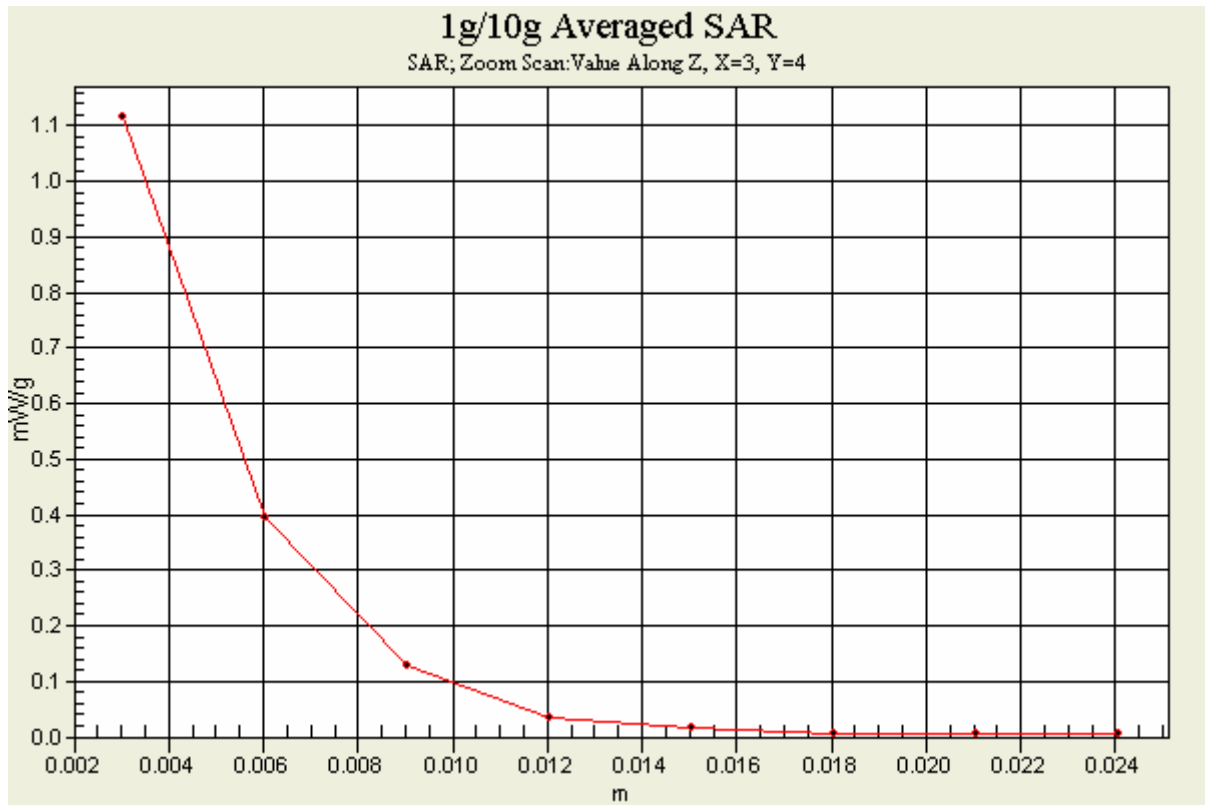

Test Laboratory: Advance Data Technology

M19-11an 40M-Ch151

DUT: Dual Band Wireless N USB Adapter ; Type: AWLL7025

Communication System: 11n 5G span40 ; Frequency: 5755 MHz ; Duty Cycle: 1:1 ; Modulation type: BPSK

Medium: MSL5800 Medium parameters used: $f = 5755$ MHz; $\sigma = 6.18$ mho/m; $\epsilon_r = 48.3$; $\rho = 1000$ kg/m³

Phantom section: Flat Section ; Separation distance : 5 mm (The bottom side of the EUT to the Phantom)

Area scan find secondary maxima within 2dB and with a peak SAR value greater than 0.0012 W/Kg

DASY4 Configuration:

- Probe: EX3DV3 - SN3506 ; ConvF(3.87, 3.87, 3.87) ; Calibrated: 2008/9/30
- Sensor-Surface: 3mm (Mechanical Surface Detection)
- Electronics: DAE3 Sn579 ; Calibrated: 2008/3/13
- Phantom: SAM 12 ; Type: SAM V4.0 ; Serial: TP 1202
- Measurement SW: DASY4, V4.7 Build 53 ; Postprocessing SW: SEMCAD, V1.8 Build 172

Low Channel 151/Area Scan (6x10x1): Measurement grid: dx=10mm, dy=10mm

Maximum value of SAR (measured) = 0.816 mW/g

Low Channel 151/Zoom Scan (8x8x8)/Cube 0: Measurement grid: dx=4.3mm, dy=4.3mm, dz=3mm

Reference Value = 8.81 V/m

Peak SAR (extrapolated) = 2.53 W/kg

SAR(1 g) = **0.565** mW/g; SAR(10 g) = 0.188 mW/g

Maximum value of SAR (measured) = 0.802 mW/g

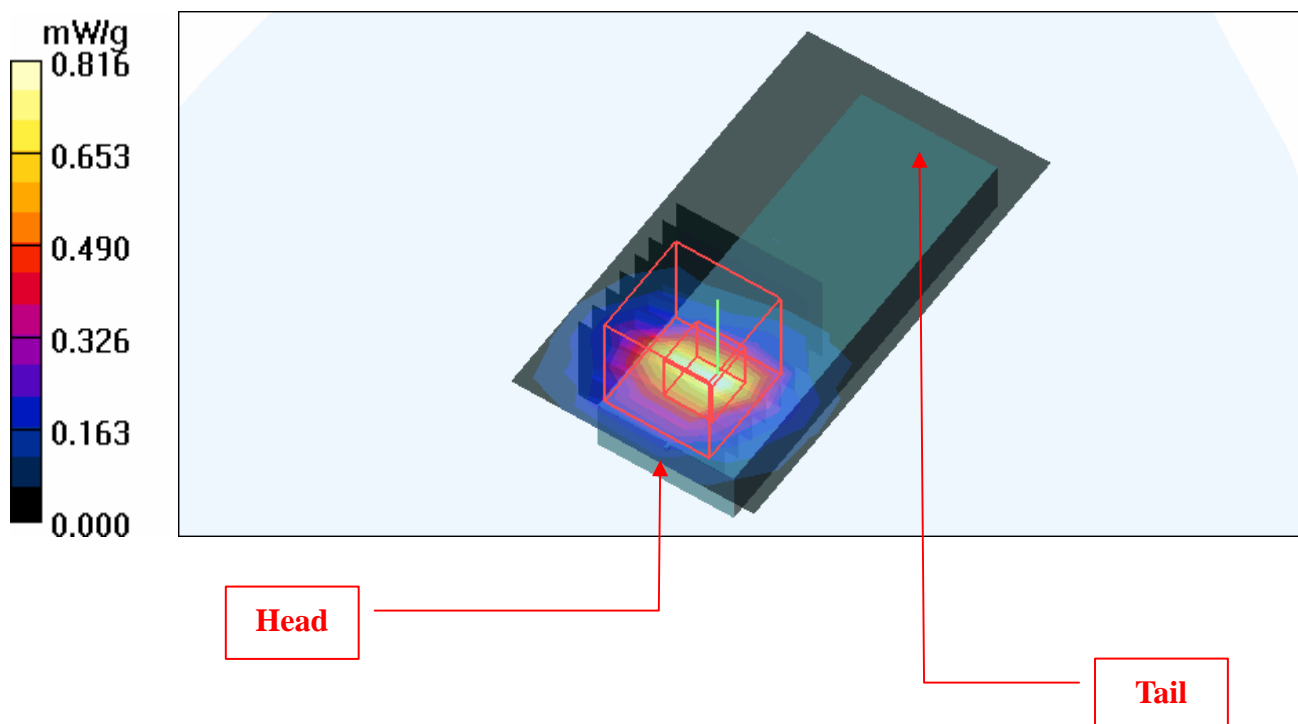

Test Laboratory: Advance Data Technology

M20-11a-Ch149

DUT: Dual Band Wireless N USB Adapter ; Type: AWLL7025

Communication System: 802.11a ; Frequency: 5745 MHz ; Duty Cycle: 1:1 ; Modulation type: BPSK
 Medium: MSL5800 Medium parameters used: $f = 5745$ MHz; $\sigma = 6.16$ mho/m; $\epsilon_r = 48.3$; $\rho = 1000$ kg/m³
 Phantom section: Flat Section ; Separation distance : 5 mm (The front side of the EUT to the Phantom)
 Area scan find secondary maxima within 2dB and with a peak SAR value greater than 0.0012 W/Kg

DASY4 Configuration:

- Probe: EX3DV3 - SN3506 ; ConvF(3.87, 3.87, 3.87) ; Calibrated: 2008/9/30
- Sensor-Surface: 3mm (Mechanical Surface Detection)
- Electronics: DAE3 Sn579 ; Calibrated: 2008/3/13
- Phantom: SAM 12 ; Type: SAM V4.0 ; Serial: TP 1202
- Measurement SW: DASY4, V4.7 Build 53 ; Postprocessing SW: SEMCAD, V1.8 Build 172

Low Channel 149/Area Scan (6x10x1): Measurement grid: dx=10mm, dy=10mm
 Maximum value of SAR (measured) = 0.386 mW/g

Low Channel 149/Zoom Scan (8x8x8)/Cube 0: Measurement grid: dx=4.3mm, dy=4.3mm, dz=3mm

Reference Value = 7.06 V/m

Peak SAR (extrapolated) = 0.845 W/kg

SAR(1 g) = 0.233 mW/g; SAR(10 g) = 0.078 mW/g

Maximum value of SAR (measured) = 0.357 mW/g

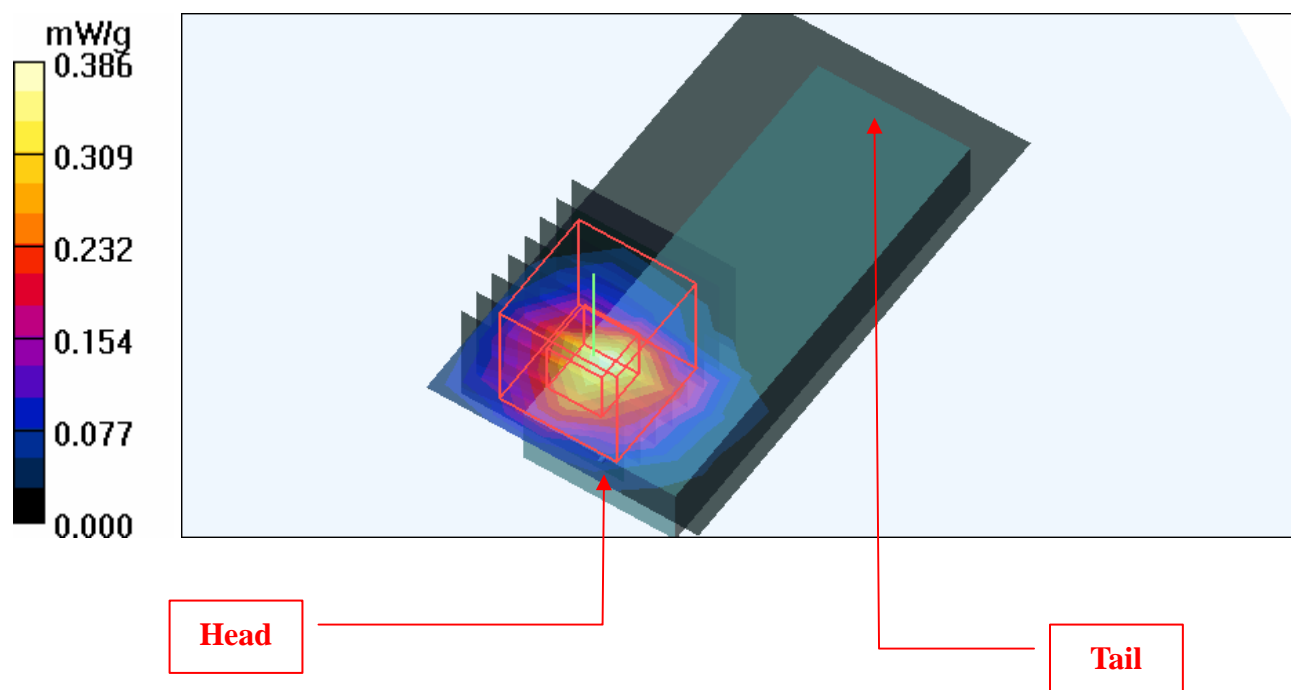

Test Laboratory: Advance Data Technology

M21-11an 20M-Ch165

DUT: Dual Band Wireless N USB Adapter ; Type: AWLL7025

Communication System: 11n 5G span20 ; Frequency: 5825 MHz ; Duty Cycle: 1:1 ; Modulation type: BPSK

Medium: MSL5800 Medium parameters used: $f = 5825$ MHz; $\sigma = 6.29$ mho/m; $\epsilon_r = 48.2$; $\rho = 1000$ kg/m³

Phantom section: Flat Section ; Separation distance : 5 mm (The front side of the EUT to the Phantom)

Area scan find secondary maxima within 2dB and with a peak SAR value greater than 0.0012 W/Kg

DASY4 Configuration:

- Probe: EX3DV3 - SN3506 ; ConvF(3.87, 3.87, 3.87) ; Calibrated: 2008/9/30
- Sensor-Surface: 3mm (Mechanical Surface Detection)
- Electronics: DAE3 Sn579 ; Calibrated: 2008/3/13
- Phantom: SAM 12 ; Type: SAM V4.0 ; Serial: TP 1202
- Measurement SW: DASY4, V4.7 Build 53 ; Postprocessing SW: SEMCAD, V1.8 Build 172

High Channel 165/Area Scan (6x10x1): Measurement grid: dx=10mm, dy=10mm

Maximum value of SAR (measured) = 0.894 mW/g

High Channel 165/Zoom Scan (8x8x8)/Cube 0: Measurement grid: dx=4.3mm, dy=4.3mm, dz=3mm

Reference Value = 10.3 V/m

Peak SAR (extrapolated) = 3.06 W/kg

SAR(1 g) = **0.660 mW/g**; SAR(10 g) = 0.229 mW/g

Maximum value of SAR (measured) = 0.901 mW/g

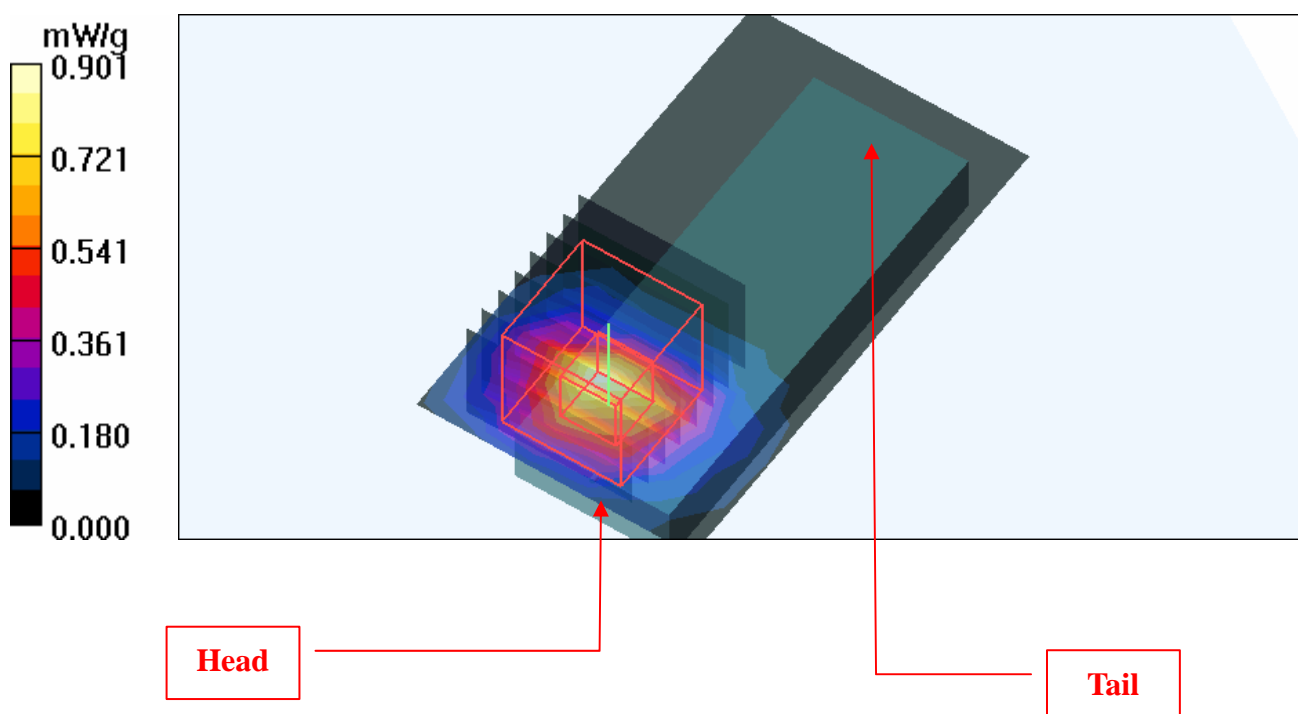

Test Laboratory: Advance Data Technology

M22-11an 40M-Ch151

DUT: Dual Band Wireless N USB Adapter ; Type: AWLL7025

Communication System: 11n 5G span40 ; Frequency: 5755 MHz ; Duty Cycle: 1:1 ; Modulation type: BPSK

Medium: MSL5800 Medium parameters used: $f = 5755$ MHz; $\sigma = 6.18$ mho/m; $\epsilon_r = 48.3$; $\rho = 1000$ kg/m³

Phantom section: Flat Section ; Separation distance : 5 mm (The front side of the EUT to the Phantom)

Area scan find secondary maxima within 2dB and with a peak SAR value greater than 0.0012 W/Kg

DASY4 Configuration:

- Probe: EX3DV3 - SN3506 ; ConvF(3.87, 3.87, 3.87) ; Calibrated: 2008/9/30
- Sensor-Surface: 3mm (Mechanical Surface Detection)
- Electronics: DAE3 Sn579 ; Calibrated: 2008/3/13
- Phantom: SAM 12 ; Type: SAM V4.0 ; Serial: TP 1202
- Measurement SW: DASY4, V4.7 Build 53 ; Postprocessing SW: SEMCAD, V1.8 Build 172

Low Channel 151/Area Scan (6x10x1): Measurement grid: dx=10mm, dy=10mm

Maximum value of SAR (measured) = 0.795 mW/g

Low Channel 151/Zoom Scan (8x8x8)/Cube 0: Measurement grid: dx=4.3mm, dy=4.3mm, dz=3mm

Reference Value = 10.3 V/m

Peak SAR (extrapolated) = 3.19 W/kg

SAR(1 g) = **0.675 mW/g**; SAR(10 g) = 0.225 mW/g

Maximum value of SAR (measured) = 0.870 mW/g

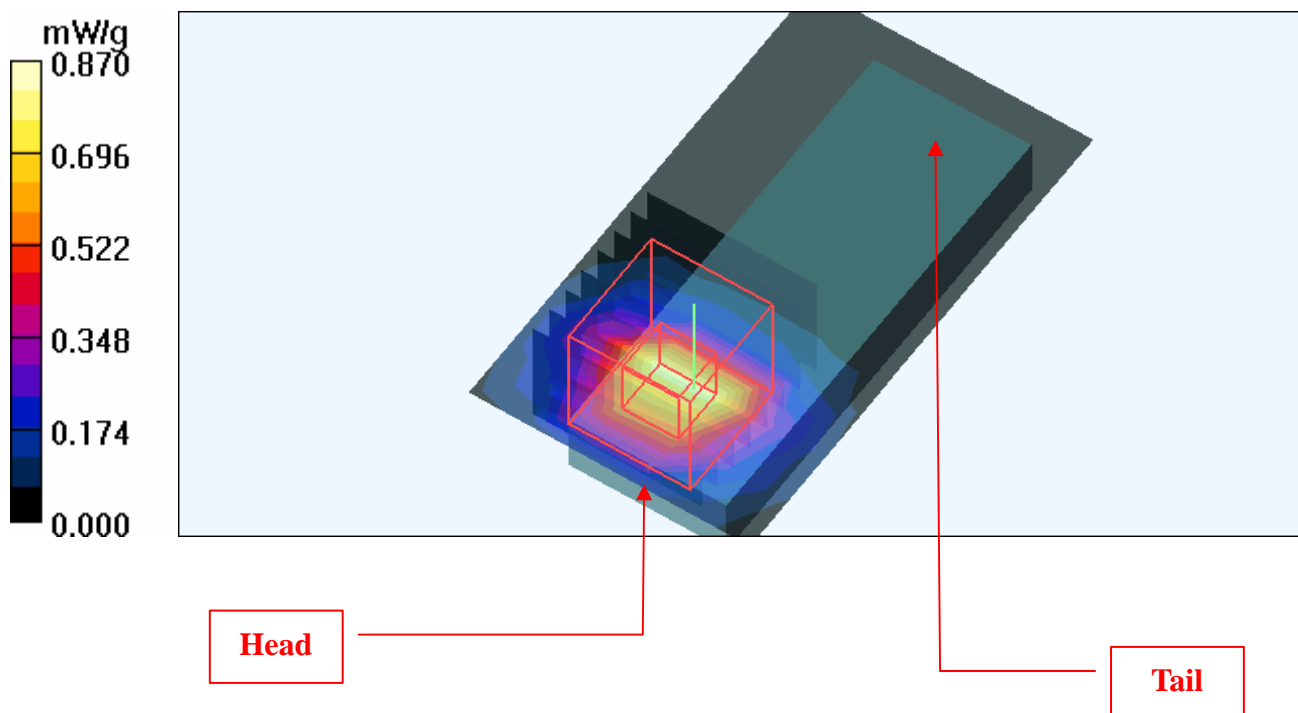

Test Laboratory: Advance Data Technology

M23-11a-Ch149

DUT: Dual Band Wireless N USB Adapter ; Type: AWLL7025

Communication System: 802.11a ; Frequency: 5745 MHz ; Duty Cycle: 1:1 ; Modulation type: BPSK
 Medium: MSL5800 Medium parameters used: $f = 5745$ MHz; $\sigma = 6.16$ mho/m; $\epsilon_r = 48.3$; $\rho = 1000$ kg/m³
 Phantom section: Flat Section ; Separation distance : 5 mm (The edge side of the EUT to the Phantom)
 Area scan find secondary maxima within 2dB and with a peak SAR value greater than 0.0012 W/Kg

DASY4 Configuration:

- Probe: EX3DV3 - SN3506 ; ConvF(3.87, 3.87, 3.87) ; Calibrated: 2008/9/30
- Sensor-Surface: 3mm (Mechanical Surface Detection)
- Electronics: DAE3 Sn579 ; Calibrated: 2008/3/13
- Phantom: SAM 12 ; Type: SAM V4.0 ; Serial: TP 1202
- Measurement SW: DASY4, V4.7 Build 53 ; Postprocessing SW: SEMCAD, V1.8 Build 172

Low Channel 149/Area Scan (6x10x1): Measurement grid: dx=10mm, dy=10mm
 Maximum value of SAR (measured) = 0.384 mW/g

Low Channel 149/Zoom Scan (8x8x8)/Cube 0: Measurement grid: dx=4.3mm, dy=4.3mm, dz=3mm

Reference Value = 7.50 V/m

Peak SAR (extrapolated) = 1.30 W/kg

SAR(1 g) = 0.302 mW/g; SAR(10 g) = 0.103 mW/g

Maximum value of SAR (measured) = 0.408 mW/g

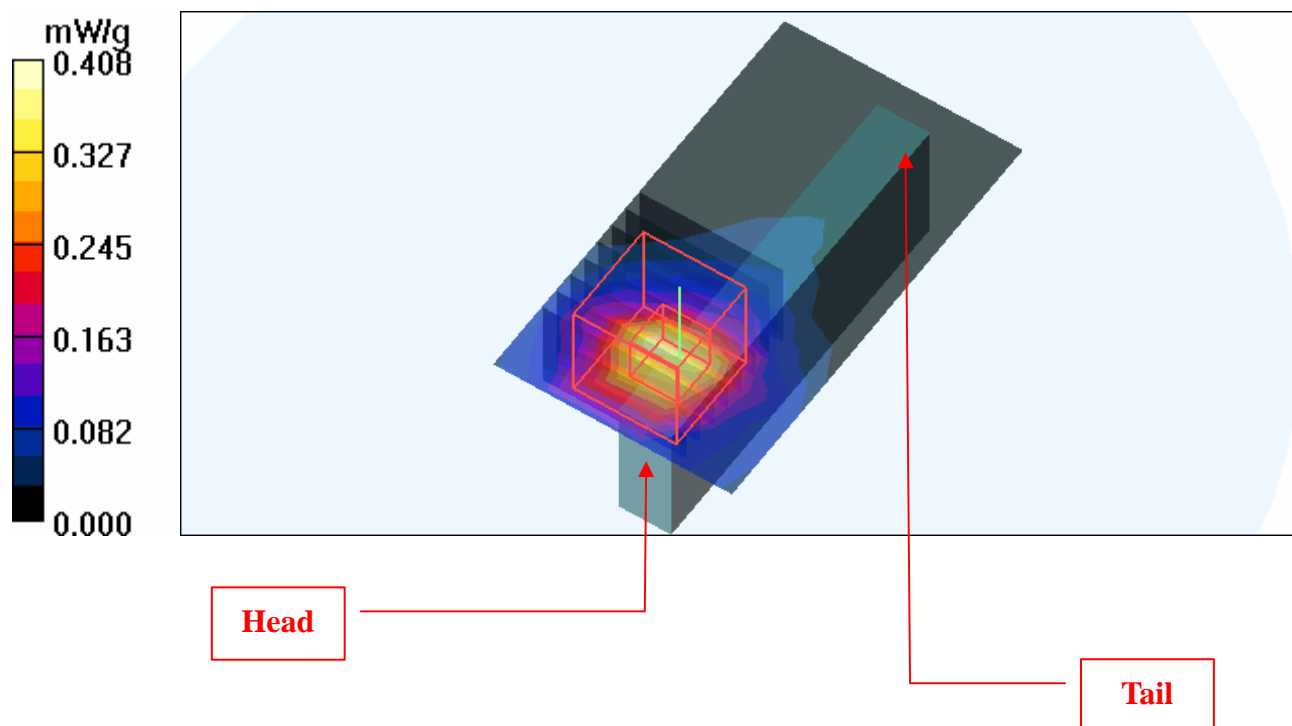

Test Laboratory: Advance Data Technology

M24-11an 20M-Ch165

DUT: Dual Band Wireless N USB Adapter ; Type: AWLL7025

Communication System: 11n 5G span20 ; Frequency: 5825 MHz ; Duty Cycle: 1:1 ; Modulation type: BPSK

Medium: MSL5800 Medium parameters used: $f = 5825$ MHz; $\sigma = 6.29$ mho/m; $\epsilon_r = 48.2$; $\rho = 1000$ kg/m³

Phantom section: Flat Section ; Separation distance : 5 mm (The edge side of the EUT to the Phantom)

Area scan find secondary maxima within 2dB and with a peak SAR value greater than 0.0012 W/Kg

DASY4 Configuration:

- Probe: EX3DV3 - SN3506 ; ConvF(3.87, 3.87, 3.87) ; Calibrated: 2008/9/30
- Sensor-Surface: 3mm (Mechanical Surface Detection)
- Electronics: DAE3 Sn579 ; Calibrated: 2008/3/13
- Phantom: SAM 12 ; Type: SAM V4.0 ; Serial: TP 1202
- Measurement SW: DASY4, V4.7 Build 53 ; Postprocessing SW: SEMCAD, V1.8 Build 172

High Channel 165/Area Scan (6x10x1): Measurement grid: dx=10mm, dy=10mm

Maximum value of SAR (measured) = 0.456 mW/g

High Channel 165/Zoom Scan (8x8x8)/Cube 0: Measurement grid: dx=4.3mm, dy=4.3mm, dz=3mm

Reference Value = 9.35 V/m

Peak SAR (extrapolated) = 1.72 W/kg

SAR(1 g) = **0.421 mW/g**; SAR(10 g) = 0.154 mW/g

Maximum value of SAR (measured) = 0.561 mW/g

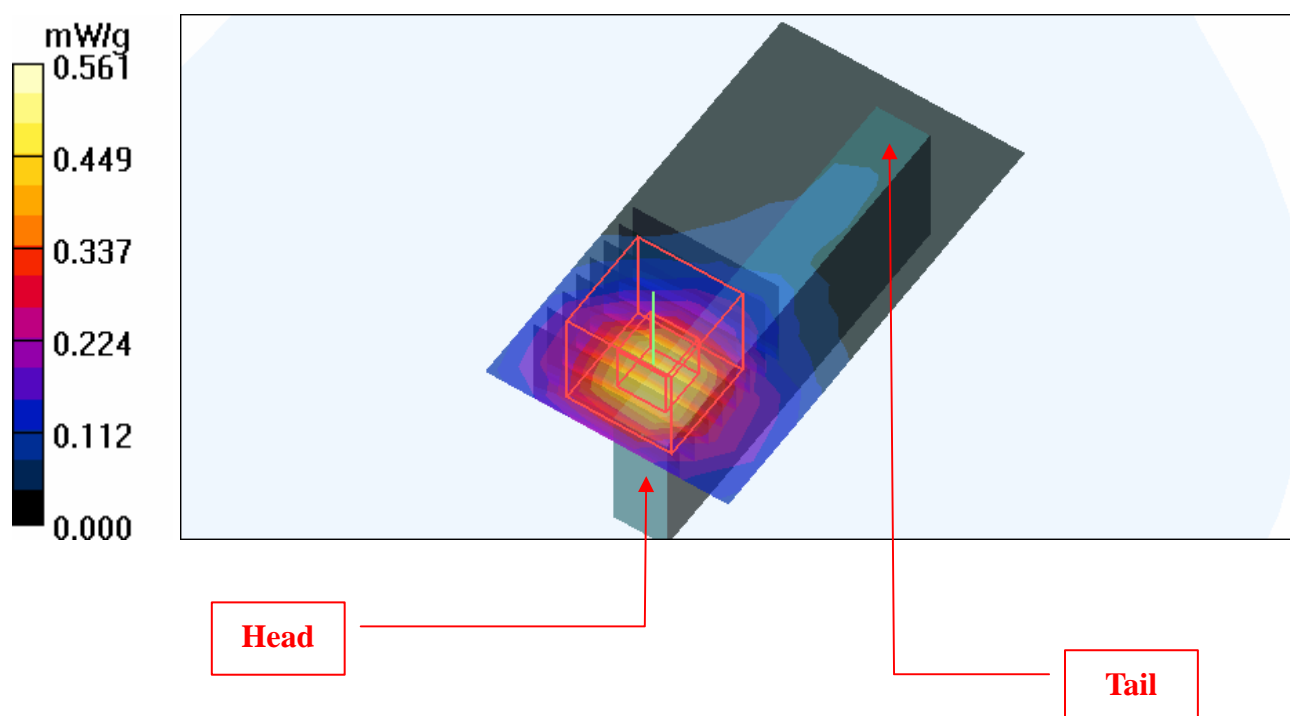

Test Laboratory: Advance Data Technology

M25-11an 40M-Ch151

DUT: Dual Band Wireless N USB Adapter ; Type: AWLL7025

Communication System: 11n 5G span40 ; Frequency: 5755 MHz ; Duty Cycle: 1:1 ; Modulation type: BPSK

Medium: MSL5800 Medium parameters used: $f = 5755$ MHz; $\sigma = 6.18$ mho/m; $\epsilon_r = 48.3$; $\rho = 1000$ kg/m³

Phantom section: Flat Section ; Separation distance : 5 mm (The edge side of the EUT to the Phantom)

Area scan find secondary maxima within 2dB and with a peak SAR value greater than 0.0012 W/Kg

DASY4 Configuration:

- Probe: EX3DV3 - SN3506 ; ConvF(3.87, 3.87, 3.87) ; Calibrated: 2008/9/30
- Sensor-Surface: 3mm (Mechanical Surface Detection)
- Electronics: DAE3 Sn579 ; Calibrated: 2008/3/13
- Phantom: SAM 12 ; Type: SAM V4.0 ; Serial: TP 1202
- Measurement SW: DASY4, V4.7 Build 53 ; Postprocessing SW: SEMCAD, V1.8 Build 172

Low Channel 151/Area Scan (6x10x1): Measurement grid: dx=10mm, dy=10mm

Maximum value of SAR (measured) = 0.360 mW/g

Low Channel 151/Zoom Scan (8x8x8)/Cube 0: Measurement grid: dx=4.3mm, dy=4.3mm, dz=3mm

Reference Value = 7.80 V/m

Peak SAR (extrapolated) = 1.30 W/kg

SAR(1 g) = 0.308 mW/g; SAR(10 g) = 0.115 mW/g

Maximum value of SAR (measured) = 0.412 mW/g

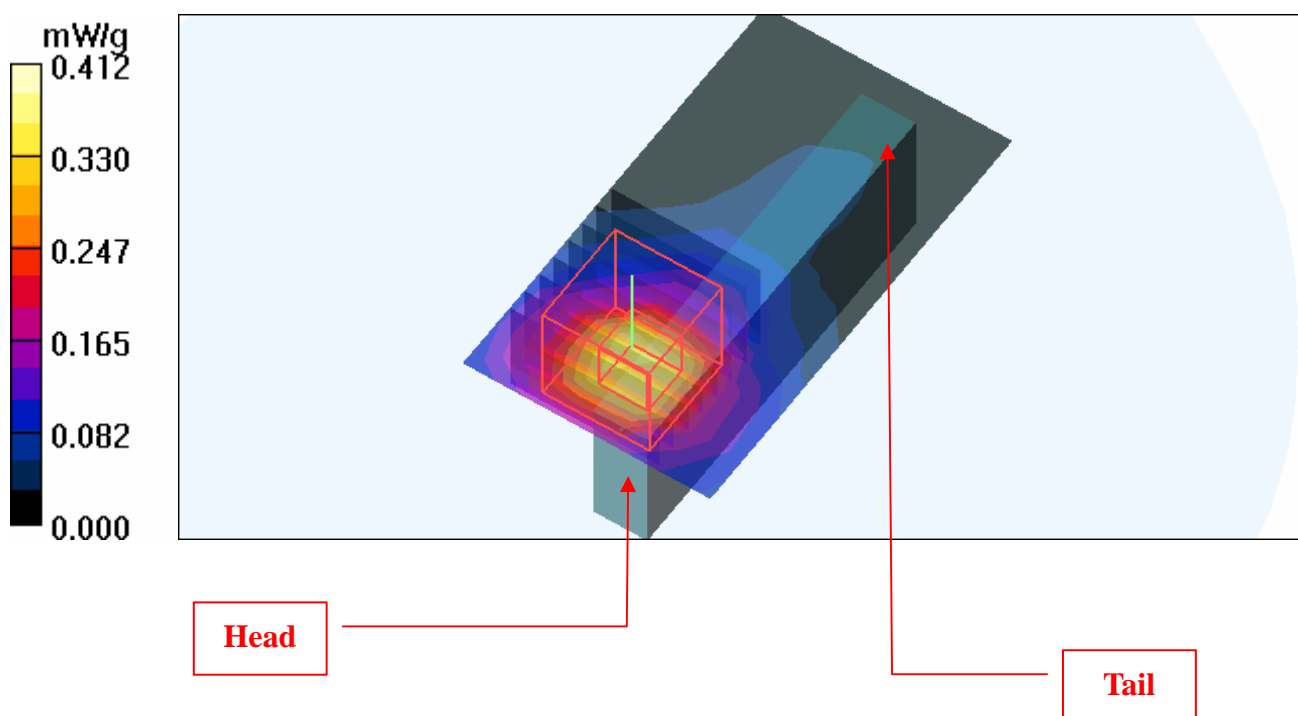

Test Laboratory: Advance Data Technology

M26-11a-Ch149

DUT: Dual Band Wireless N USB Adapter ; Type: AWLL7025

Communication System: 802.11a ; Frequency: 5745 MHz ; Duty Cycle: 1:1 ; Modulation type: BPSK
 Medium: MSL5800 Medium parameters used: $f = 5745$ MHz; $\sigma = 6.16$ mho/m; $\epsilon_r = 48.3$; $\rho = 1000$ kg/m³
 Phantom section: Flat Section ; Separation distance : 5 mm (The edge side of the EUT to the Phantom)
 Area scan find secondary maxima within 2dB and with a peak SAR value greater than 0.0012 W/Kg

DASY4 Configuration:

- Probe: EX3DV3 - SN3506 ; ConvF(3.87, 3.87, 3.87) ; Calibrated: 2008/9/30
- Sensor-Surface: 3mm (Mechanical Surface Detection)
- Electronics: DAE3 Sn579 ; Calibrated: 2008/3/13
- Phantom: SAM 12 ; Type: SAM V4.0 ; Serial: TP 1202
- Measurement SW: DASY4, V4.7 Build 53 ; Postprocessing SW: SEMCAD, V1.8 Build 172

Low Channel 149/Area Scan (6x11x1): Measurement grid: dx=10mm, dy=10mm
 Maximum value of SAR (measured) = 0.047 mW/g

Low Channel 149/Zoom Scan (8x8x8)/Cube 0: Measurement grid: dx=4.3mm, dy=4.3mm, dz=3mm
 Reference Value = 2.90 V/m
 Peak SAR (extrapolated) = 0.163 W/kg
SAR(1 g) = 0.032 mW/g; SAR(10 g) = 0.015 mW/g

Low Channel 149/Zoom Scan (8x8x8)/Cube 1: Measurement grid: dx=4.3mm, dy=4.3mm, dz=3mm
 Reference Value = 2.90 V/m
 Peak SAR (extrapolated) = 0.250 W/kg
SAR(1 g) = 0.034 mW/g; SAR(10 g) = 0.014 mW/g
 Maximum value of SAR (measured) = 0.049 mW/g

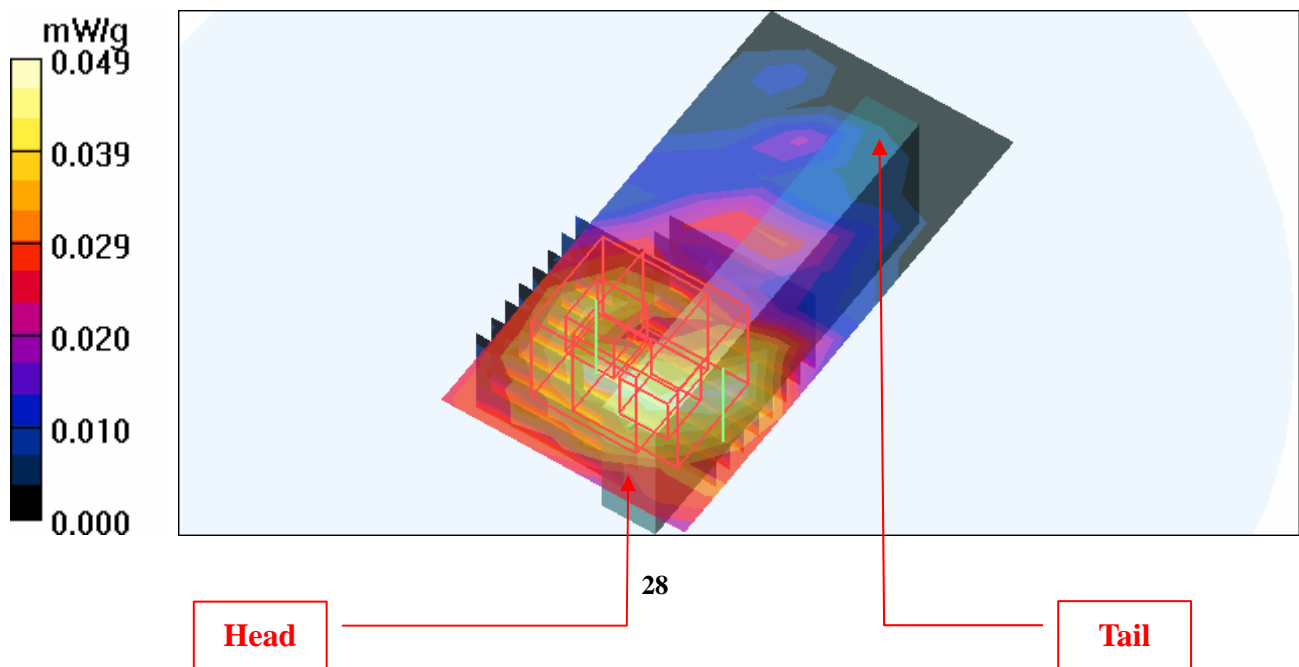

Test Laboratory: Advance Data Technology

M27-11an 20M-Ch165

DUT: Dual Band Wireless N USB Adapter ; Type: AWLL7025

Communication System: 11n 5G span20 ; Frequency: 5825 MHz ; Duty Cycle: 1:1 ; Modulation type: BPSK

Medium: MSL5800 Medium parameters used: $f = 5825$ MHz; $\sigma = 6.29$ mho/m; $\epsilon_r = 48.2$; $\rho = 1000$ kg/m³

Phantom section: Flat Section ; Separation distance : 5 mm (The edge side of the EUT to the Phantom)

Area scan find secondary maxima within 2dB and with a peak SAR value greater than 0.0012 W/Kg

DASY4 Configuration:

- Probe: EX3DV3 - SN3506 ; ConvF(3.87, 3.87, 3.87) ; Calibrated: 2008/9/30
- Sensor-Surface: 3mm (Mechanical Surface Detection)
- Electronics: DAE3 Sn579 ; Calibrated: 2008/3/13
- Phantom: SAM 12 ; Type: SAM V4.0 ; Serial: TP 1202
- Measurement SW: DASY4, V4.7 Build 53 ; Postprocessing SW: SEMCAD, V1.8 Build 172

High Channel 165/Area Scan (6x10x1): Measurement grid: dx=10mm, dy=10mm

Maximum value of SAR (measured) = 0.689 mW/g

High Channel 165/Zoom Scan (8x8x8)/Cube 0: Measurement grid: dx=4.3mm, dy=4.3mm, dz=3mm

Reference Value = 10.4 V/m

Peak SAR (extrapolated) = 2.57 W/kg

SAR(1 g) = **0.548 mW/g**; SAR(10 g) = 0.204 mW/g

Maximum value of SAR (measured) = 0.748 mW/g

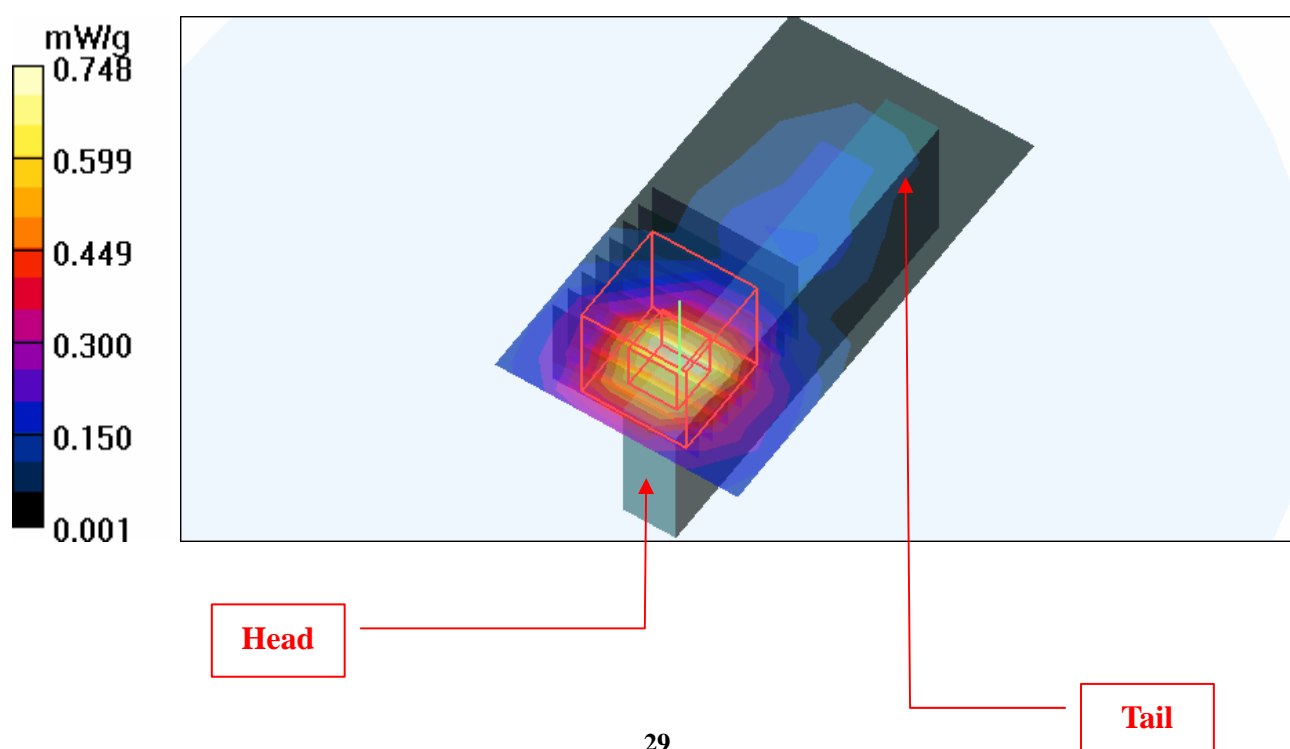

Test Laboratory: Advance Data Technology

M28-11an 40M-Ch151

DUT: Dual Band Wireless N USB Adapter ; Type: AWLL7025

Communication System: 11n 5G span40 ; Frequency: 5755 MHz ; Duty Cycle: 1:1 ; Modulation type: BPSK

Medium: MSL5800 Medium parameters used: $f = 5755$ MHz; $\sigma = 6.18$ mho/m; $\epsilon_r = 48.3$; $\rho = 1000$ kg/m³

Phantom section: Flat Section ; Separation distance : 5 mm (The edge side of the EUT to the Phantom)

Area scan find secondary maxima within 2dB and with a peak SAR value greater than 0.0012 W/Kg

DASY4 Configuration:

- Probe: EX3DV3 - SN3506 ; ConvF(3.87, 3.87, 3.87) ; Calibrated: 2008/9/30
- Sensor-Surface: 3mm (Mechanical Surface Detection)
- Electronics: DAE3 Sn579 ; Calibrated: 2008/3/13
- Phantom: SAM 12 ; Type: SAM V4.0 ; Serial: TP 1202
- Measurement SW: DASY4, V4.7 Build 53 ; Postprocessing SW: SEMCAD, V1.8 Build 172

Low Channel 151/Area Scan (6x10x1): Measurement grid: dx=10mm, dy=10mm

Maximum value of SAR (measured) = 0.401 mW/g

Low Channel 151/Zoom Scan (8x8x8)/Cube 0: Measurement grid: dx=4.3mm, dy=4.3mm, dz=3mm

Reference Value = 8.06 V/m

Peak SAR (extrapolated) = 1.43 W/kg

SAR(1 g) = **0.342 mW/g**; SAR(10 g) = 0.126 mW/g

Maximum value of SAR (measured) = 0.465 mW/g

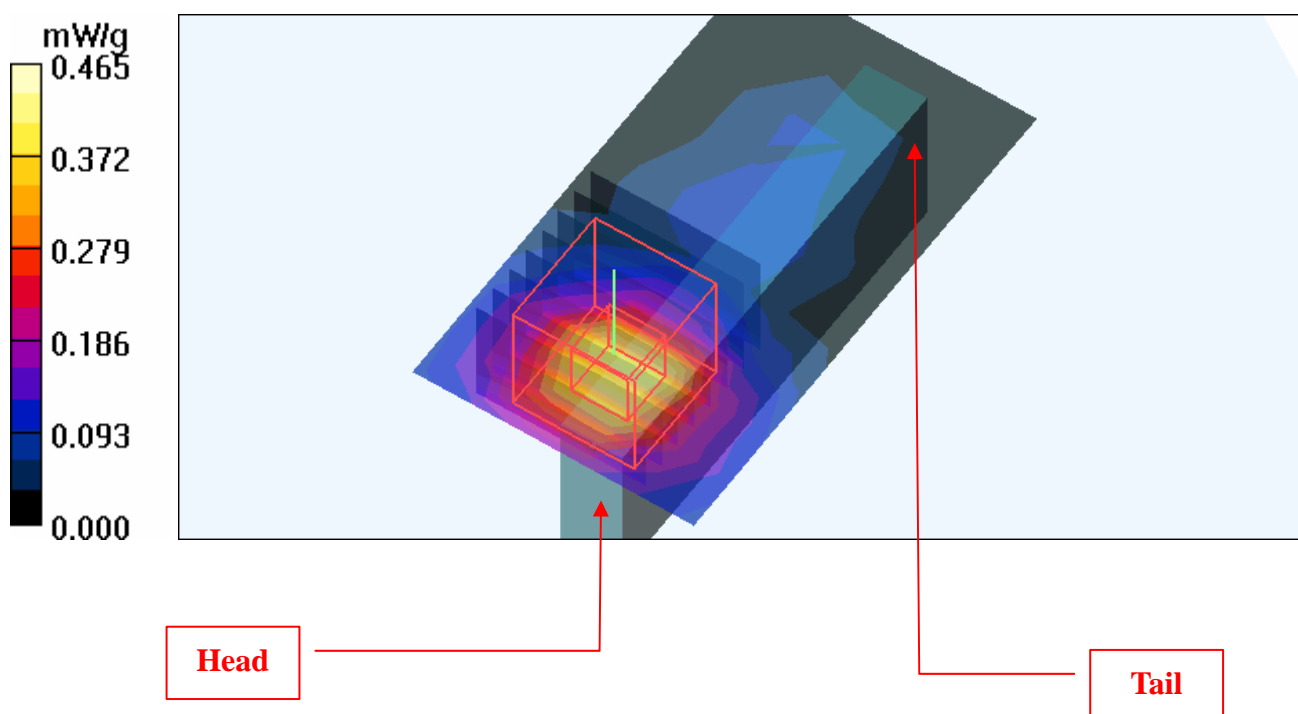

Test Laboratory: Advance Data Technology

System Validation Check-MSL 2450MHz

DUT: Dipole 2450 MHz ; Type: D2450V2 ; Serial: 737 ; Test Frequency: 2450 MHz

Communication System: CW ; Frequency: 2450 MHz; Duty Cycle: 1:1; Modulation type: CW
Medium: MSL2450; Medium parameters used: $f = 2450$ MHz; $\sigma = 2$ mho/m; $\epsilon_r = 53.4$; $\rho = 1000$ kg/m³ ;
Liquid level : 150 mm
Phantom section: Flat Section ; Separation distance : 10 mm (The feetpoint of the dipole to the Phantom)
Air temp. : 23.6 degrees ; Liquid temp. : 22.8 degrees

DASY4 Configuration:

- Probe: EX3DV3 - SN3506 ; ConvF(7.52, 7.52, 7.52) ; Calibrated: 2008/9/30
- Sensor-Surface: 3mm (Mechanical Surface Detection)
- Electronics: DAE3 Sn579; Calibrated: 2008/3/13
- Phantom: SAM 12; Type: SAM V4.0; Serial: TP 1202
- Measurement SW: DASY4, V4.7 Build 53; Postprocessing SW: SEMCAD, V1.8 Build 172

d=10mm, Pin=250mW/Area Scan (5x7x1): Measurement grid: dx=15mm, dy=15mm
Maximum value of SAR (measured) = 14.6 mW/g

d=10mm, Pin=250mW/Zoom Scan (7x7x7)/Cube 0: Measurement grid: dx=5mm, dy=5mm, dz=5mm

Reference Value = 91.2 V/m; Power Drift = -0.133 dB

Peak SAR (extrapolated) = 27.7 W/kg

SAR(1 g) = 12.8 mW/g; SAR(10 g) = 5.93 mW/g

Maximum value of SAR (measured) = 14.5 mW/g

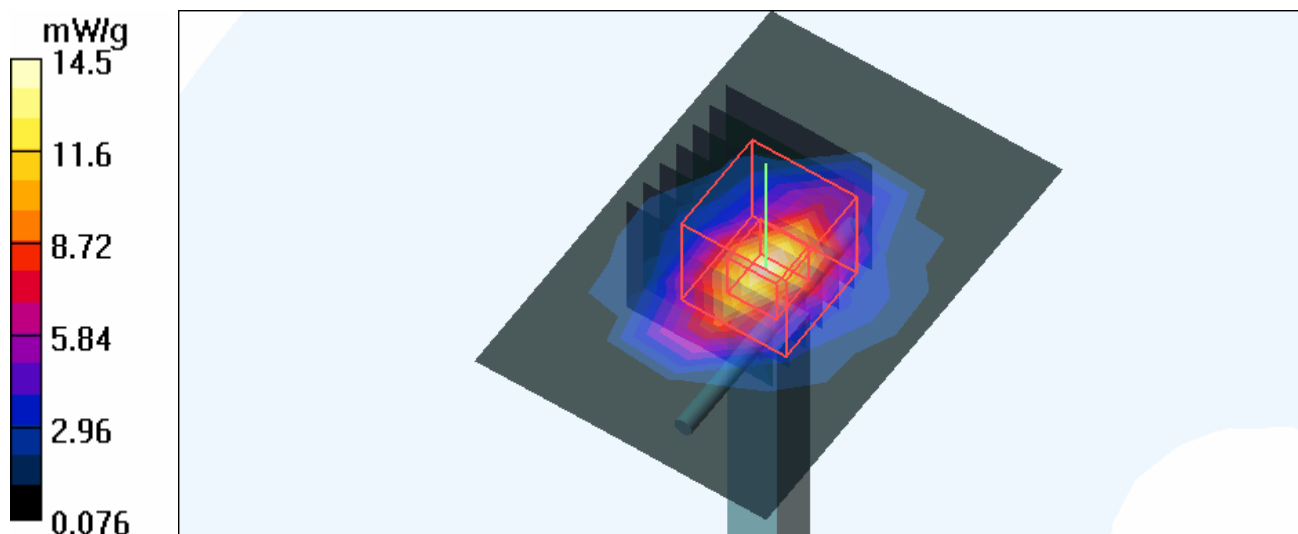

Test Laboratory: Advance Data Technology

System Validation Check-MSL 5GHz

DUT: Dipole 5 GHz ; Type: D5GHzV2 ; Serial: 1018 ; Test Frequency: 5800 MHz

Communication System: CW ; Frequency: 5800 MHz; Duty Cycle: 1:1; Modulation type: CW
 Medium: MSL5800; Medium parameters used: $f = 5800$ MHz; $\sigma = 6.25$ mho/m; $\epsilon_r = 48.2$; $\rho = 1000$ kg/m³ ; Liquid level : 155 mm
 Phantom section: Flat Section ; Separation distance : 10 mm (The feetpoint of the dipole to the Phantom) Air temp. : 23.2 degrees ; Liquid temp. : 22.3 degrees

DASY4 Configuration:

- Probe: EX3DV3 - SN3506 ; ConvF(3.87, 3.87, 3.87) ; Calibrated: 2008/9/30
- Sensor-Surface: 3mm (Mechanical Surface Detection)
- Electronics: DAE3 Sn579; Calibrated: 2008/3/13
- Phantom: SAM 12; Type: SAM V4.0; Serial: TP 1202
- Measurement SW: DASY4, V4.7 Build 53; Postprocessing SW: SEMCAD, V1.8 Build 172

f=5800, d=10mm, Pin=100mW/Area Scan (6x6x1): Measurement grid: dx=10mm, dy=10mm
 Maximum value of SAR (measured) = 6.78 mW/g

f=5800, d=10mm, Pin=100mW/Zoom Scan (8x8x8)/Cube 0: Measurement grid: dx=4.3mm, dy=4.3mm, dz=3mm

Reference Value = 41.7 V/m; Power Drift = -0.013 dB

Peak SAR (extrapolated) = 33.6 W/kg

SAR(1 g) = 6.9 mW/g; SAR(10 g) = 1.91 mW/g

Maximum value of SAR (measured) = 9.47 mW/g

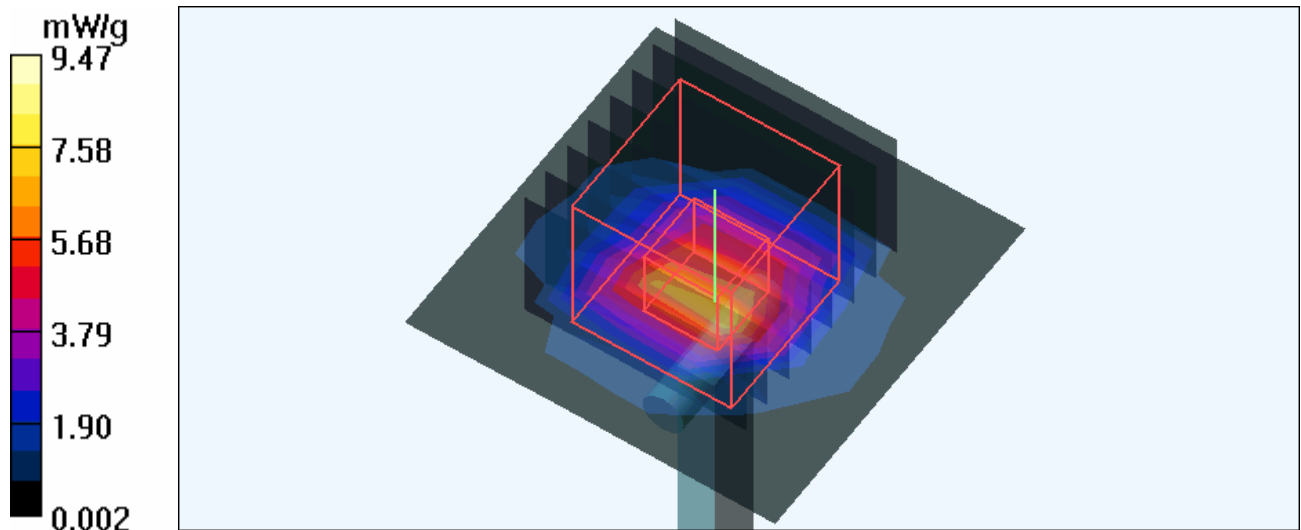

APPENDIX B: ADT SAR MEASUREMENT SYSTEM



APPENDIX C: PHOTOGRAPHS OF SYSTEM VALIDATION





APPENDIX D: SYSTEM CERTIFICATE & CALIBRATION

D1: SAM PHANTOM

Schmid & Partner Engineering AG

Zeughausstrasse 43, 8004 Zurich, Switzerland, Phone +41 1 245 97 00, Fax +41 1 245 97 79

Certificate of conformity / First Article Inspection

Item	SAM Twin Phantom V4.0
Type No	QD 000 P40 CA
Series No	TP-1150 and higher
Manufacturer / Origin	Untersee Composites Hauptstr. 69 CH-8559 Fruthwilen Switzerland

Tests

The series production process used allows the limitation to test of first articles. Complete tests were made on the pre-series Type No. QD 000 P40 AA, Serial No. TP-1001 and on the series first article Type No. QD 000 P40 BA, Serial No. TP-1006. Certain parameters have been retested using further series units (called samples).

Test	Requirement	Details	Units tested
Shape	Compliance with the geometry according to the CAD model.	IT'IS CAD File (*)	First article, Samples
Material thickness	Compliant with the requirements according to the standards	2mm +/- 0.2mm in specific areas	First article, Samples
Material parameters	Dielectric parameters for required frequencies	200 MHz – 3 GHz Relative permittivity < 5 Loss tangent < 0.05.	Material sample TP 104-5
Material resistivity	The material has been tested to be compatible with the liquids defined in the standards	Liquid type HSL 1800 and others according to the standard.	Pre-series, First article

Standards

- [1] CENELEC EN 50361
- [2] IEEE P1528-200x draft 6.5
- [3] IEC PT 62209 draft 0.9

(*) The IT'IS CAD file is derived from [2] and is also within the tolerance requirements of the shapes of [1] and [3].

Conformity

Based on the sample tests above, we certify that this item is in compliance with the uncertainty requirements of SAR measurements specified in standard [1] and draft standards [2] and [3].

Date 28.02.2002

Signature / Stamp

F. Bombault

**Schmid & Partner
Engineering AG**

Zeughausstrasse 43, CH-8004 Zurich
Tel. +41 1 245 97 00, Fax +41 1 245 97 79

Johannes Kofler



A D T

D2: DOSIMETRIC E-FIELD PROBE



Accredited by the Swiss Accreditation Service (SAS)
The Swiss Accreditation Service is one of the signatories to the EA
Multilateral Agreement for the recognition of calibration certificates

Accreditation No.: **SCS 108**

Client **ADT (Auden)**

Certificate No: **EX3-3506_Sep08**

CALIBRATION CERTIFICATE

Object **EX3DV3 - SN:3506**

Calibration procedure(s) **QA CAL-01.v6, QA CAL-14.v3 and QA CAL-23.v3
Calibration procedure for dosimetric E-field probes**

Calibration date: **September 30, 2008**

Condition of the calibrated item **In Tolerance**

This calibration certificate documents the traceability to national standards, which realize the physical units of measurements (SI).
The measurements and the uncertainties with confidence probability are given on the following pages and are part of the certificate.

All calibrations have been conducted in the closed laboratory facility: environment temperature (22 ± 3)°C and humidity < 70%.

Calibration Equipment used (M&TE critical for calibration)

Primary Standards	ID #	Cal Date (Certificate No.)	Scheduled Calibration
Power meter E4419B	GB41293874	1-Apr-08 (No. 217-00788)	Apr-09
Power sensor E4412A	MY41495277	1-Apr-08 (No. 217-00788)	Apr-09
Power sensor E4412A	MY41498087	1-Apr-08 (No. 217-00788)	Apr-09
Reference 3 dB Attenuator	SN: S5054 (3c)	1-Jul-08 (No. 217-00865)	Jul-09
Reference 20 dB Attenuator	SN: S5086 (20b)	31-Mar-08 (No. 217-00787)	Apr-09
Reference 30 dB Attenuator	SN: S5129 (30b)	1-Jul-08 (No. 217-00866)	Jul-09
Reference Probe ES3DV2	SN: 3013	2-Jan-08 (No. ES3-3013_Jan08)	Jan-09
DAE4	SN: 660	9-Sep-08 (No. DAE4-660_Sep08)	Sep-09
Secondary Standards	ID #	Check Date (in house)	Scheduled Check
RF generator HP 8648C	US3642U01700	4-Aug-99 (in house check Oct-07)	In house check: Oct-09
Network Analyzer HP 8753E	US37390585	18-Oct-01 (in house check Oct-07)	In house check: Oct-08

	Name	Function	Signature
Calibrated by:	Katja Pokovic	Technical Manager	
Approved by:	Niels Kuster	Quality Manager	

Issued: September 30, 2008

This calibration certificate shall not be reproduced except in full without written approval of the laboratory.



Accredited by the Swiss Accreditation Service (SAS)
The Swiss Accreditation Service is one of the signatories to the EA
Multilateral Agreement for the recognition of calibration certificates

Accreditation No.: **SCS 108**

Glossary:

TSL	tissue simulating liquid
NORM _{x,y,z}	sensitivity in free space
ConvF	sensitivity in TSL / NORM _{x,y,z}
DCP	diode compression point
Polarization φ	φ rotation around probe axis
Polarization ϑ	ϑ rotation around an axis that is in the plane normal to probe axis (at measurement center), i.e., $\vartheta = 0$ is normal to probe axis

Calibration is Performed According to the Following Standards:

- IEEE Std 1528-2003, "IEEE Recommended Practice for Determining the Peak Spatial-Averaged Specific Absorption Rate (SAR) in the Human Head from Wireless Communications Devices: Measurement Techniques", December 2003
- IEC 62209-1, "Procedure to measure the Specific Absorption Rate (SAR) for hand-held devices used in close proximity to the ear (frequency range of 300 MHz to 3 GHz)", February 2005

Methods Applied and Interpretation of Parameters:

- NORM_{x,y,z}**: Assessed for E-field polarization $\vartheta = 0$ ($f \leq 900$ MHz in TEM-cell; $f > 1800$ MHz: R22 waveguide). NORM_{x,y,z} are only intermediate values, i.e., the uncertainties of NORM_{x,y,z} does not effect the E²-field uncertainty inside TSL (see below *ConvF*).
- NORM(f)_{x,y,z}** = NORM_{x,y,z} * *frequency_response* (see Frequency Response Chart). This linearization is implemented in DASY4 software versions later than 4.2. The uncertainty of the frequency response is included in the stated uncertainty of *ConvF*.
- DCP_{x,y,z}**: DCP are numerical linearization parameters assessed based on the data of power sweep (no uncertainty required). DCP does not depend on frequency nor media.
- ConvF and Boundary Effect Parameters**: Assessed in flat phantom using E-field (or Temperature Transfer Standard for $f \leq 800$ MHz) and inside waveguide using analytical field distributions based on power measurements for $f > 800$ MHz. The same setups are used for assessment of the parameters applied for boundary compensation (alpha, depth) of which typical uncertainty values are given. These parameters are used in DASY4 software to improve probe accuracy close to the boundary. The sensitivity in TSL corresponds to NORM_{x,y,z} * *ConvF* whereby the uncertainty corresponds to that given for *ConvF*. A frequency dependent *ConvF* is used in DASY version 4.4 and higher which allows extending the validity from ± 50 MHz to ± 100 MHz.
- Spherical isotropy (3D deviation from isotropy)**: in a field of low gradients realized using a flat phantom exposed by a patch antenna.
- Sensor Offset**: The sensor offset corresponds to the offset of virtual measurement center from the probe tip (on probe axis). No tolerance required.

Probe EX3DV3

SN:3506

Manufactured:	February 18, 2004
Last calibrated:	March 21, 2008
Repaired:	September 24, 2008
Recalibrated:	September 30, 2008

Calibrated for DASY Systems

(Note: non-compatible with DASY2 system!)

DASY - Parameters of Probe: EX3DV3 SN:3506Sensitivity in Free Space^ADiode Compression^B

NormX	0.73 ± 10.1%	$\mu\text{V}/(\text{V}/\text{m})^2$	DCP X	96 mV
NormY	0.84 ± 10.1%	$\mu\text{V}/(\text{V}/\text{m})^2$	DCP Y	96 mV
NormZ	0.79 ± 10.1%	$\mu\text{V}/(\text{V}/\text{m})^2$	DCP Z	92 mV

Sensitivity in Tissue Simulating Liquid (Conversion Factors)

Please see Page 8.

Boundary Effect

TSL 900 MHz Typical SAR gradient: 5 % per mm

Sensor Center to Phantom Surface Distance		2.0 mm	3.0 mm
SAR _{be} [%]	Without Correction Algorithm	9.1	5.3
SAR _{be} [%]	With Correction Algorithm	0.8	0.5

TSL 1750 MHz Typical SAR gradient: 10 % per mm

Sensor Center to Phantom Surface Distance		2.0 mm	3.0 mm
SAR _{be} [%]	Without Correction Algorithm	6.8	3.2
SAR _{be} [%]	With Correction Algorithm	0.6	0.4

Sensor Offset

Probe Tip to Sensor Center **1.0 mm**

The reported uncertainty of measurement is stated as the standard uncertainty of measurement multiplied by the coverage factor $k=2$, which for a normal distribution corresponds to a coverage probability of approximately 95%.

^A The uncertainties of NormX,Y,Z do not affect the E²-field uncertainty inside TSL (see Page 8).^B Numerical linearization parameter: uncertainty not required.

Frequency Response of E-Field

(TEM-Cell:ifi110 EXX, Waveguide: R22)

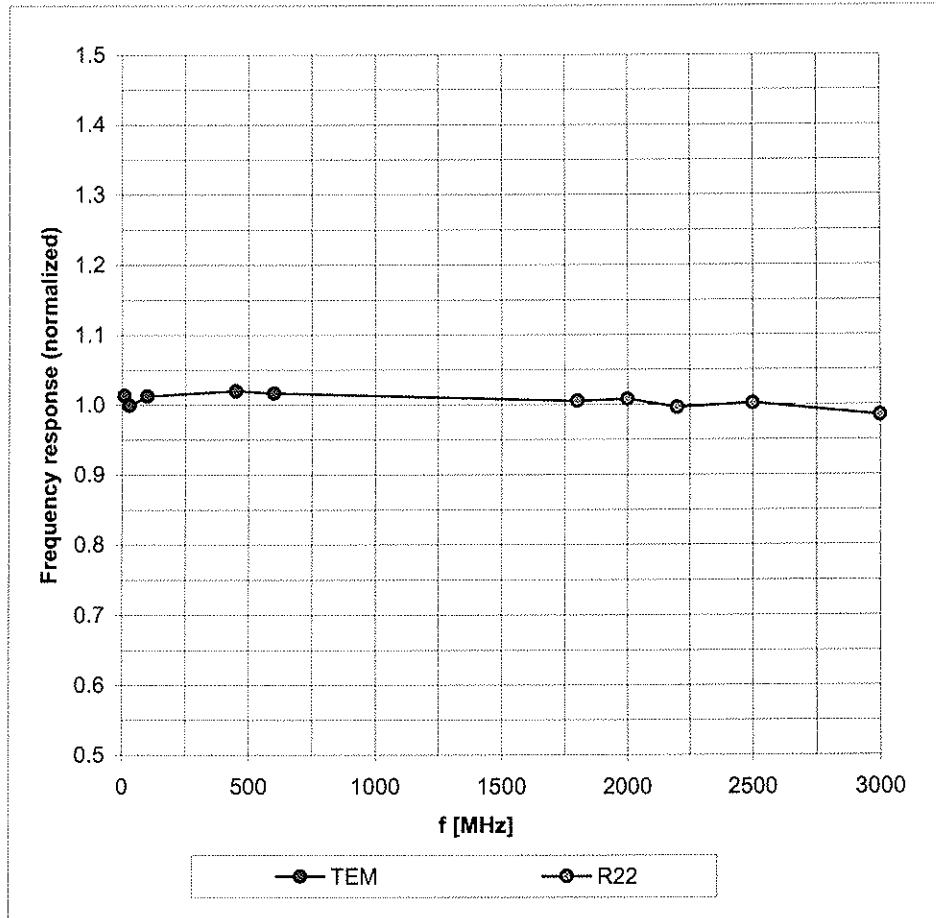

Uncertainty of Frequency Response of E-field: $\pm 6.3\%$ ($k=2$)

Receiving Pattern (ϕ), $\vartheta = 0^\circ$

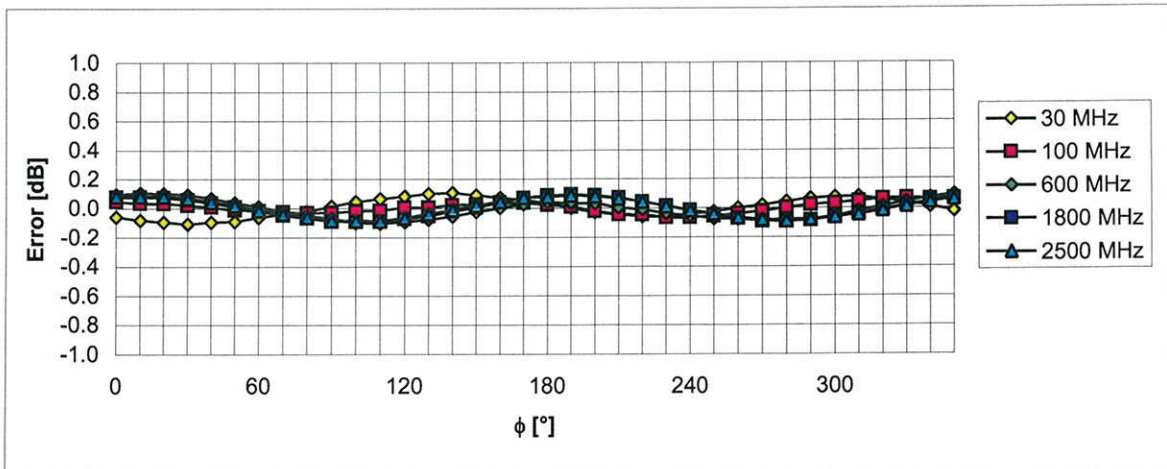
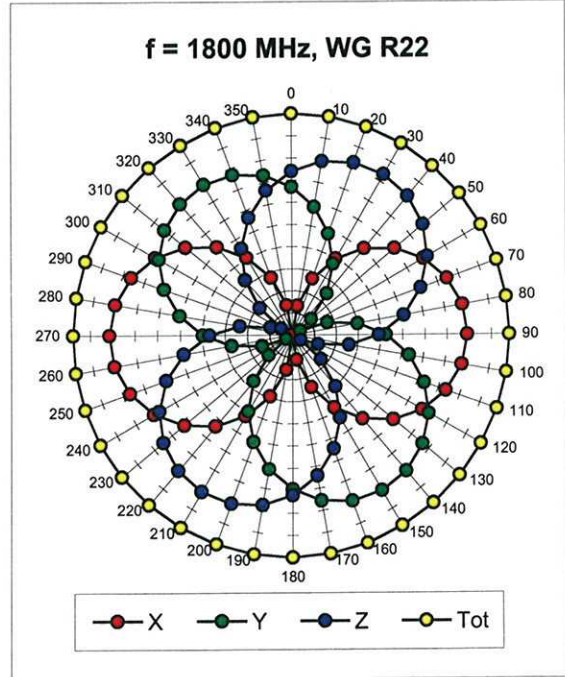
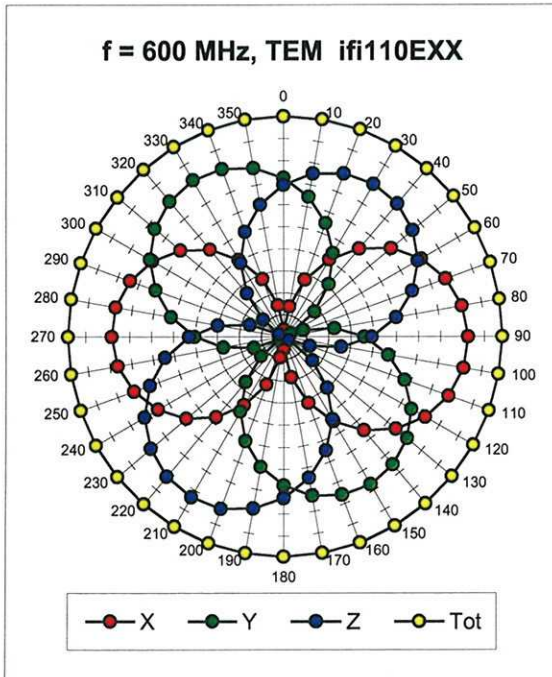

Uncertainty of Axial Isotropy Assessment: $\pm 0.5\%$ ($k=2$)

Dynamic Range f(SAR_{head}) (Waveguide R22, f = 1800 MHz)

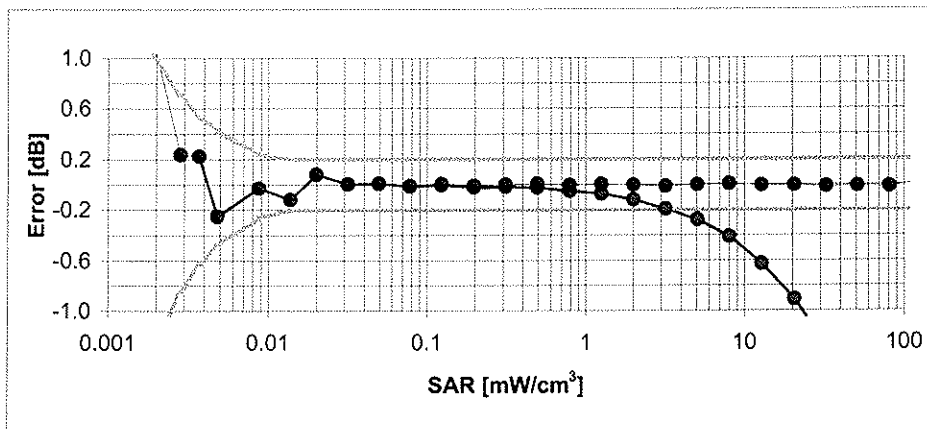
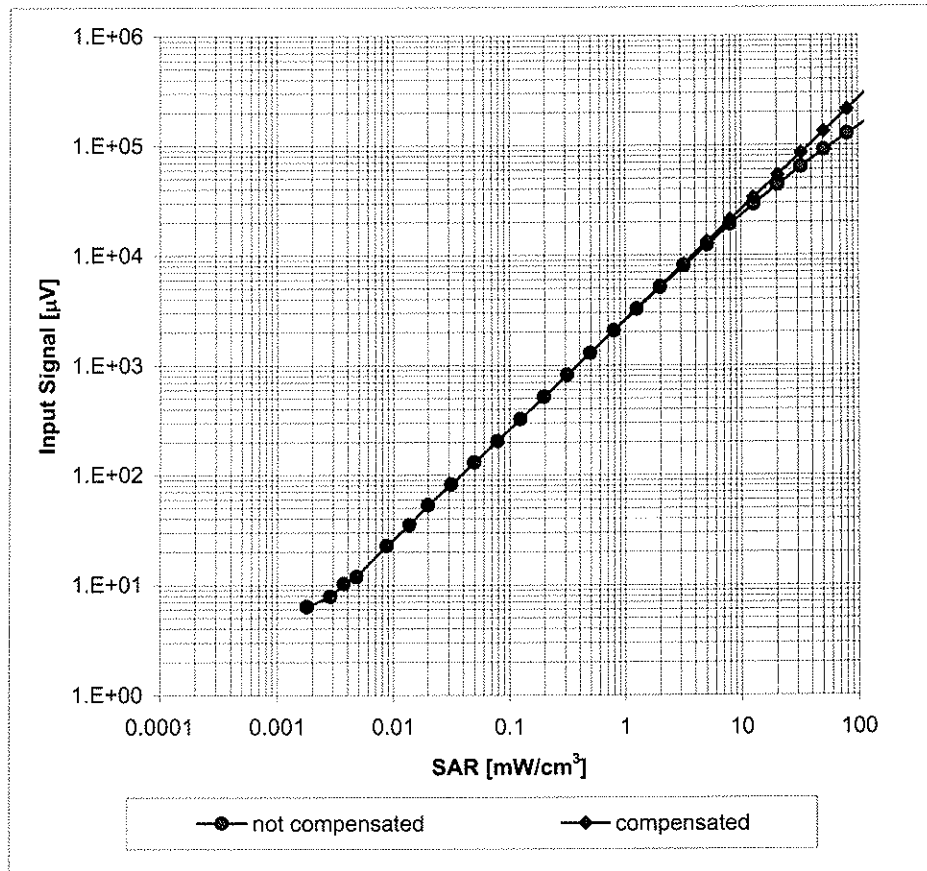

Uncertainty of Linearity Assessment: ± 0.6% (k=2)

Conversion Factor Assessment

f [MHz]	Validity [MHz] ^c	TSL	Permittivity	Conductivity	Alpha	Depth	ConvF Uncertainty
900	± 50 / ± 100	Head	41.5 ± 5%	0.97 ± 5%	0.19	1.30	10.04 ± 11.0% (k=2)
1750	± 50 / ± 100	Head	40.1 ± 5%	1.37 ± 5%	0.60	0.63	8.77 ± 11.0% (k=2)
1950	± 50 / ± 100	Head	40.0 ± 5%	1.40 ± 5%	0.37	0.76	8.30 ± 11.0% (k=2)
2300	± 50 / ± 100	Head	39.4 ± 5%	1.71 ± 5%	0.59	0.60	8.22 ± 11.0% (k=2)
2450	± 50 / ± 100	Head	39.2 ± 5%	1.80 ± 5%	0.32	0.81	7.83 ± 11.0% (k=2)
2600	± 50 / ± 100	Head	39.0 ± 5%	1.96 ± 5%	0.26	0.93	7.80 ± 11.0% (k=2)
3500	± 50 / ± 100	Head	37.9 ± 5%	2.91 ± 5%	0.40	0.90	7.75 ± 13.1% (k=2)
4950	± 50 / ± 100	Head	36.3 ± 5%	4.40 ± 5%	0.43	1.75	5.48 ± 13.1% (k=2)
5200	± 50 / ± 100	Head	36.0 ± 5%	4.66 ± 5%	0.45	1.75	5.12 ± 13.1% (k=2)
5300	± 50 / ± 100	Head	35.9 ± 5%	4.76 ± 5%	0.46	1.75	4.81 ± 13.1% (k=2)
5500	± 50 / ± 100	Head	35.6 ± 5%	4.96 ± 5%	0.48	1.75	4.52 ± 13.1% (k=2)
5600	± 50 / ± 100	Head	35.5 ± 5%	5.07 ± 5%	0.53	1.75	4.29 ± 13.1% (k=2)
5800	± 50 / ± 100	Head	35.3 ± 5%	5.27 ± 5%	0.50	1.75	4.38 ± 13.1% (k=2)
900	± 50 / ± 100	Body	55.0 ± 5%	1.05 ± 5%	0.25	1.11	10.01 ± 11.0% (k=2)
1750	± 50 / ± 100	Body	53.4 ± 5%	1.49 ± 5%	0.50	0.67	8.54 ± 11.0% (k=2)
1950	± 50 / ± 100	Body	53.3 ± 5%	1.52 ± 5%	0.26	0.91	8.34 ± 11.0% (k=2)
2300	± 50 / ± 100	Body	52.8 ± 5%	1.85 ± 5%	0.37	0.88	7.78 ± 11.0% (k=2)
2450	± 50 / ± 100	Body	52.7 ± 5%	1.95 ± 5%	0.33	0.90	7.52 ± 11.0% (k=2)
2600	± 50 / ± 100	Body	52.5 ± 5%	2.16 ± 5%	0.39	0.85	7.43 ± 11.0% (k=2)
3500	± 50 / ± 100	Body	51.3 ± 5%	3.31 ± 5%	0.48	1.00	7.03 ± 13.1% (k=2)
4950	± 50 / ± 100	Body	49.4 ± 5%	5.01 ± 5%	0.50	1.80	4.38 ± 13.1% (k=2)
5200	± 50 / ± 100	Body	49.0 ± 5%	5.30 ± 5%	0.50	1.80	4.25 ± 13.1% (k=2)
5300	± 50 / ± 100	Body	48.5 ± 5%	5.42 ± 5%	0.53	1.80	3.95 ± 13.1% (k=2)
5500	± 50 / ± 100	Body	48.6 ± 5%	5.65 ± 5%	0.52	1.80	3.76 ± 13.1% (k=2)
5600	± 50 / ± 100	Body	48.5 ± 5%	5.77 ± 5%	0.50	1.80	3.92 ± 13.1% (k=2)
5800	± 50 / ± 100	Body	48.2 ± 5%	6.00 ± 5%	0.48	1.80	3.87 ± 13.1% (k=2)

^c The validity of ± 100 MHz only applies for DASY v4.4 and higher (see Page 2). The uncertainty is the RSS of the ConvF uncertainty at calibration frequency and the uncertainty for the indicated frequency band.

Deviation from Isotropy in HSL

Error (ϕ, ϑ), $f = 900$ MHz

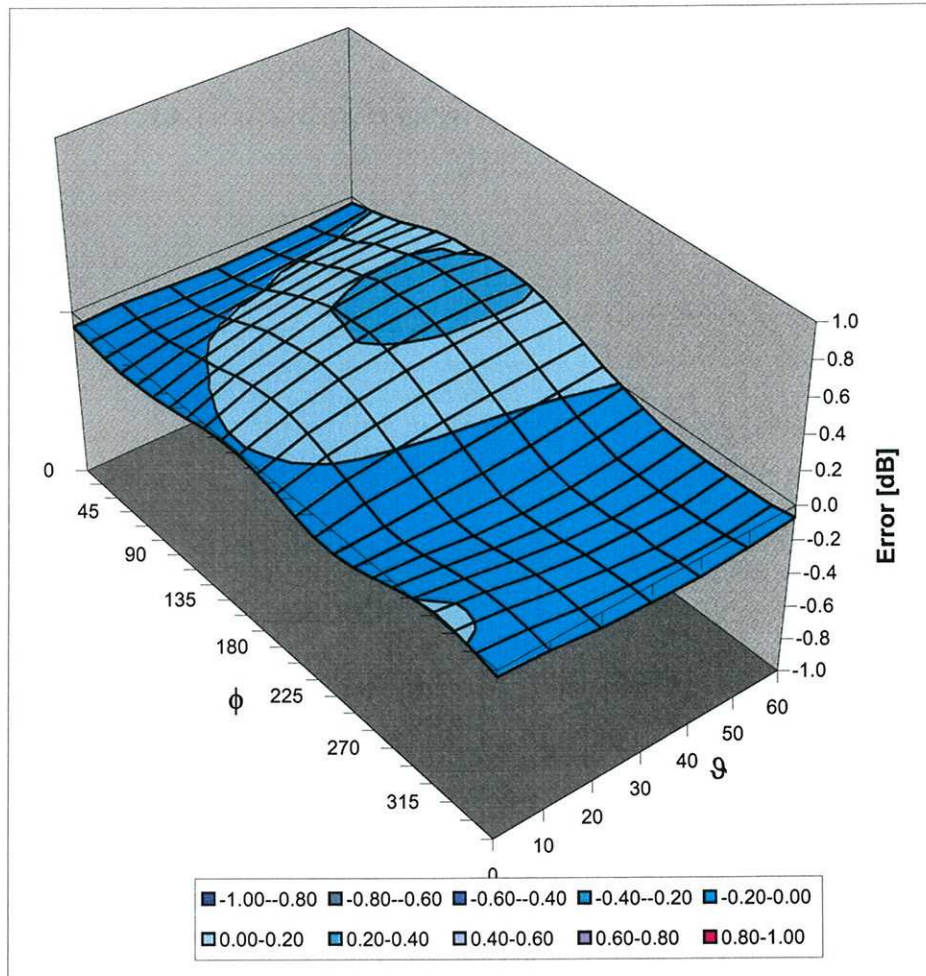

Uncertainty of Spherical Isotropy Assessment: $\pm 2.6\%$ ($k=2$)



A D T

D3: DAE

IMPORTANT NOTICE

USAGE OF THE DAE 3

The DAE unit is a delicate, high precision instrument and requires careful treatment by the user. There are no serviceable parts inside the DAE. Special attention shall be given to the following points:

Battery Exchange: The battery cover of the DAE3 unit is connected to a fragile 3-pin battery connector. Customer is responsible to apply utmost caution not to bend or damage the connector when changing batteries.

Shipping of the DAE: Before shipping the DAE to SPEAG for calibration Customer shall remove the batteries and pack the DAE in an antistatic bag. The packaging shall protect the DAE from impacts during transportation. The package shall be marked to indicate that a fragile instrument is inside.

E-Stop Failures: Touch detection may be malfunctioning due to broken magnets in the E-stop. Rough handling of the E-stop may lead to damage of these magnets. Touch and collision errors are often caused by dust and dirt accumulated in the E-stop. To prevent E-stop failure, Customer shall always mount the probe to the DAE carefully and keep the DAE unit in a non-dusty environment if not used for measurements.

Repair: Minor repairs are performed at no extra cost during the annual calibration. However, SPEAG reserves the right to charge for any repair especially if rough unprofessional handling caused the defect.

Important Note:

Warranty and calibration is void if the DAE unit is disassembled partly or fully by the Customer.

Important Note:

Never attempt to grease or oil the E-stop assembly. Cleaning and readjusting of the E-stop assembly is allowed by certified SPEAG personnel only and is part of the annual calibration procedure.



Accredited by the Swiss Accreditation Service (SAS)
The Swiss Accreditation Service is one of the signatories to the EA
Multilateral Agreement for the recognition of calibration certificates

Accreditation No.: **SCS 108**

Client **ADT (Auden)**

Certificate No: **DAE3-579_Mar08**

CALIBRATION CERTIFICATE

Object **DAE3 - SD 000 D03 AA - SN: 579**

Calibration procedure(s) **QA CAL-06.v12
Calibration procedure for the data acquisition electronics (DAE)**

Calibration date: **March 13, 2008**

Condition of the calibrated item **In Tolerance**

This calibration certificate documents the traceability to national standards, which realize the physical units of measurements (SI).
The measurements and the uncertainties with confidence probability are given on the following pages and are part of the certificate.

All calibrations have been conducted in the closed laboratory facility: environment temperature (22 ± 3)°C and humidity < 70%.

Calibration Equipment used (M&TE critical for calibration)

Primary Standards	ID #	Cal Date (Calibrated by, Certificate No.)	Scheduled Calibration
Fluke Process Calibrator Type 702	SN: 6295803	04-Oct-07 (Elcal AG, No: 6467)	Oct-08
Keithley Multimeter Type 2001	SN: 0810278	03-Oct-07 (Elcal AG, No: 6465)	Oct-08
Secondary Standards	ID #	Check Date (in house)	Scheduled Check
Calibrator Box V1.1	SE UMS 006 AB 1004	25-Jun-07 (SPEAG, in house check)	In house check Jun-08

Calibrated by: **Name** Dominique Steffen **Function** Technician **Signature**

Approved by: **Name** Fin Bornholt **Function** R&D Director **Signature**

Issued: March 13, 2008

This calibration certificate shall not be reproduced except in full without written approval of the laboratory.



Accredited by the Swiss Federal Office of Metrology and Accreditation
The Swiss Accreditation Service is one of the signatories to the EA
Multilateral Agreement for the recognition of calibration certificates

Accreditation No.: **SCS 108**

Glossary

DAE data acquisition electronics
Connector angle information used in DASY system to align probe sensor X to the robot coordinate system.

Methods Applied and Interpretation of Parameters

- *DC Voltage Measurement:* Calibration Factor assessed for use in DASY system by comparison with a calibrated instrument traceable to national standards. The figure given corresponds to the full scale range of the voltmeter in the respective range.
- *Connector angle:* The angle of the connector is assessed measuring the angle mechanically by a tool inserted. Uncertainty is not required.
- The following parameters as documented in the Appendix contain technical information as a result from the performance test and require no uncertainty.
 - *DC Voltage Measurement Linearity:* Verification of the Linearity at +10% and -10% of the nominal calibration voltage. Influence of offset voltage is included in this measurement.
 - *Common mode sensitivity:* Influence of a positive or negative common mode voltage on the differential measurement.
 - *Channel separation:* Influence of a voltage on the neighbor channels not subject to an input voltage.
 - *AD Converter Values with inputs shorted:* Values on the internal AD converter corresponding to zero input voltage
 - *Input Offset Measurement:* Output voltage and statistical results over a large number of zero voltage measurements.
 - *Input Offset Current:* Typical value for information; Maximum channel input offset current, not considering the input resistance.
 - *Input resistance:* DAE input resistance at the connector, during internal auto-zeroing and during measurement.
 - *Low Battery Alarm Voltage:* Typical value for information. Below this voltage, a battery alarm signal is generated.
 - *Power consumption:* Typical value for information. Supply currents in various operating modes.

DC Voltage Measurement

A/D - Converter Resolution nominal

High Range: 1LSB = 6.1 μ V, full range = -100...+300 mV

Low Range: 1LSB = 61nV, full range = -1.....+3mV

DASY measurement parameters: Auto Zero Time: 3 sec; Measuring time: 3 sec

Calibration Factors	X	Y	Z
High Range	404.417 \pm 0.1% (k=2)	404.496 \pm 0.1% (k=2)	404.250 \pm 0.1% (k=2)
Low Range	3.96392 \pm 0.7% (k=2)	3.98485 \pm 0.7% (k=2)	3.94736 \pm 0.7% (k=2)

Connector Angle

Connector Angle to be used in DASY system	0 $^{\circ}$ \pm 1 $^{\circ}$
---	---------------------------------

Appendix

1. DC Voltage Linearity

High Range		Input (μV)	Reading (μV)	Error (%)
Channel X	+ Input	200000	199999.9	0.00
Channel X	+ Input	20000	20006.39	0.03
Channel X	- Input	20000	-19997.12	-0.01
Channel Y	+ Input	200000	199999.6	0.00
Channel Y	+ Input	20000	20003.48	0.02
Channel Y	- Input	20000	-19999.40	0.00
Channel Z	+ Input	200000	200000.5	0.00
Channel Z	+ Input	20000	20005.11	0.03
Channel Z	- Input	20000	-20000.56	0.00

Low Range		Input (μV)	Reading (μV)	Error (%)
Channel X	+ Input	2000	1999.9	0.00
Channel X	+ Input	200	200.77	0.38
Channel X	- Input	200	-199.61	-0.19
Channel Y	+ Input	2000	1999.9	0.00
Channel Y	+ Input	200	199.52	-0.24
Channel Y	- Input	200	-200.01	0.00
Channel Z	+ Input	2000	2000	0.00
Channel Z	+ Input	200	200.04	0.02
Channel Z	- Input	200	-200.10	0.05

2. Common mode sensitivity

DASY measurement parameters: Auto Zero Time: 3 sec; Measuring time: 3 sec

	Common mode Input Voltage (mV)	High Range Average Reading (μV)	Low Range Average Reading (μV)
Channel X	200	7.31	7.04
	- 200	-5.43	-5.14
Channel Y	200	-4.64	3.79
	- 200	9.97	2.98
Channel Z	200	9.71	9.67
	- 200	-10.05	-10.25

3. Channel separation

DASY measurement parameters: Auto Zero Time: 3 sec; Measuring time: 3 sec

	Input Voltage (mV)	Channel X (μV)	Channel Y (μV)	Channel Z (μV)
Channel X	200	-	0.91	1.12
Channel Y	200	1.44	-	4.27
Channel Z	200	-2.15	0.74	-

4. AD-Converter Values with inputs shorted

DASY measurement parameters: Auto Zero Time: 3 sec; Measuring time: 3 sec

	High Range (LSB)	Low Range (LSB)
Channel X	16337	17475
Channel Y	16186	16655
Channel Z	15807	16761

5. Input Offset Measurement

DASY measurement parameters: Auto Zero Time: 3 sec; Measuring time: 3 sec

Input 10M Ω

	Average (μ V)	min. Offset (μ V)	max. Offset (μ V)	Std. Deviation (μ V)
Channel X	-0.02	-1.05	2.46	0.44
Channel Y	-1.99	-3.37	-0.92	0.33
Channel Z	2.37	0.38	3.81	0.43

6. Input Offset Current

Nominal Input circuitry offset current on all channels: <25fA

7. Input Resistance

	Zeroing (MOhm)	Measuring (MOhm)
Channel X	0.2001	199.5
Channel Y	0.2000	202.9
Channel Z	0.1999	204.2

8. Low Battery Alarm Voltage (verified during pre test)

Typical values	Alarm Level (VDC)
Supply (+ Vcc)	+7.9
Supply (- Vcc)	-7.6

9. Power Consumption (verified during pre test)

Typical values	Switched off (mA)	Stand by (mA)	Transmitting (mA)
Supply (+ Vcc)	+0.0	+6	+14
Supply (- Vcc)	-0.01	-8	-9