



FCC TEST REPORT

REPORT NO.: RF950912L08

MODEL NO.: USR5419

RECEIVED: Sep. 13, 2006

TESTED: Sep. 19 ~ 27, 2006

ISSUED: Oct. 02, 2006

APPLICANT: Gemtek Technology Co., Ltd.

ADDRESS: No.1, Jen Ai Road, Hsinchu Industrial Park,
Hukou Hsinchu, Taiwan, R.O.C. 303

ISSUED BY: Advance Data Technology Corporation

LAB ADDRESS: 47 14th Lin, Chiapau Tsun, Linko, Taipei, Taiwan,
R.O.C.

TEST LOCATION: No. 19, Hwa Ya 2nd Rd., Kueishan, Taoyuan,
Taiwan, R.O.C.

This test report consists of 104 pages in total. It may be duplicated completely for legal use with the approval of the applicant. It should not be reproduced except in full, without the written approval of our laboratory. The client should not use it to claim product endorsement by CNLA, A2LA or any government agencies. The test results in the report only apply to the tested sample.





TABLE OF CONTENTS

1.	CERTIFICATION	4
2.	SUMMARY OF TEST RESULTS	5
2.1	MEASUREMENT UNCERTAINTY	5
3.	GENERAL INFORMATION.....	6
3.1	GENERAL DESCRIPTION OF EUT.....	6
3.2	DESCRIPTION OF TEST MODES.....	7
3.2.1	CONFIGURATION OF SYSTEM UNDER TEST	7
3.2.2	TEST MODE APPLICABILITY AND TESTED CHANNEL DETAIL.....	8
3.3	GENERAL DESCRIPTION OF APPLIED STANDARDS	10
3.4	DESCRIPTION OF SUPPORT UNITS	11
4.	TEST TYPES AND RESULTS	12
4.1	CONDUCTED EMISSION MEASUREMENT	12
4.1.1	LIMITS OF CONDUCTED EMISSION MEASUREMENT.....	12
4.1.2	TEST INSTRUMENTS.....	12
4.1.3	TEST PROCEDURES	13
4.1.4	DEVIATION FROM TEST STANDARD	13
4.1.5	TEST SETUP	14
4.1.6	EUT OPERATING CONDITIONS	14
4.1.7	TEST RESULTS	15
4.2	RADIATED EMISSION MEASUREMENT	33
4.2.1	LIMITS OF RADIATED EMISSION MEASUREMENT.....	33
4.2.2	TEST INSTRUMENTS.....	34
4.2.3	TEST PROCEDURES	35
4.2.4	DEVIATION FROM TEST STANDARD	35
4.2.5	TEST SETUP	36
4.2.6	EUT OPERATING CONDITIONS	36
4.2.7	TEST RESULTS	37
4.3	6dB BANDWIDTH MEASUREMENT	52
4.3.1	LIMITS OF 6dB BANDWIDTH MEASUREMENT	52
4.3.2	TEST INSTRUMENTS.....	52
4.3.3	TEST PROCEDURE.....	52
4.3.4	DEVIATION FROM TEST STANDARD	52
4.3.5	TEST SETUP	53
4.3.6	EUT OPERATING CONDITIONS	53
4.3.7	TEST RESULTS	54
4.4	MAXIMUM PEAK OUTPUT POWER	66
4.4.1	LIMITS OF MAXIMUM PEAK OUTPUT POWER MEASUREMENT	66
4.4.2	INSTRUMENTS.....	66
4.4.3	TEST PROCEDURES	66
4.4.4	DEVIATION FROM TEST STANDARD	66
4.4.5	TEST SETUP	67
4.4.6	EUT OPERATING CONDITIONS	67



4.4.7	TEST RESULTS	68
4.5	POWER SPECTRAL DENSITY MEASUREMENT	70
4.5.1	LIMITS OF POWER SPECTRAL DENSITY MEASUREMENT	70
4.5.2	TEST INSTRUMENTS.....	70
4.5.3	TEST PROCEDURE.....	70
4.5.4	DEVIATION FROM TEST STANDARD	70
4.5.5	TEST SETUP	71
4.5.6	EUT OPERATING CONDITION	71
4.5.7	TEST RESULTS	72
4.6	BAND EDGES MEASUREMENT	84
4.6.1	LIMITS OF BAND EDGES MEASUREMENT	84
4.6.2	TEST INSTRUMENTS.....	84
4.6.3	TEST PROCEDURE.....	84
4.6.4	DEVIATION FROM TEST STANDARD	85
4.6.5	EUT OPERATING CONDITION	85
4.6.6	TEST RESULTS	86
4.7	ANTENNA REQUIREMENT	102
4.7.1	STANDARD APPLICABLE	102
4.7.2	ANTENNA CONNECTED CONSTRUCTION	102
6.	INFORMATION ON THE TESTING LABORATORIES	103
APPENDIX-A	A-1



1. CERTIFICATION

PRODUCT: USRobotics Wireless Nd₁ PCI Adapter
MODEL: USR5419
BRAND: USRobotics
APPLICANT: Gemtek Technology Co., Ltd.
TESTED: Sep. 19 ~ 27, 2006
TEST SAMPLE: ENGINEERING SAMPLE
STANDARDS: FCC Part 15, Subpart C (Section 15.247),
ANSI C63.4-2003

The above equipment has been tested by **Advance Data Technology Corporation**, and found compliance with the requirement of the above standards. The test record, data evaluation & Equipment Under Test (EUT) configurations represented herein are true and accurate accounts of the measurements of the sample's EMC characteristics under the conditions specified in this report.

PREPARED BY : Rennie Wang , **DATE:** Oct. 02, 2006
Rennie Wang

TECHNICAL ACCEPTANCE : Long Chen , **DATE:** Oct. 02, 2006
Responsible for RF Long Chen

APPROVED BY : Gary Chang , **DATE:** Oct. 02, 2006
Gary Chang / Supervisor

2. SUMMARY OF TEST RESULTS

The EUT has been tested according to the following specifications:

APPLIED STANDARD: FCC Part 15, Subpart C			
STANDARD SECTION	TEST TYPE AND LIMIT	RESULT	REMARK
15.207	AC Power Conducted Emission	PASS	Meet the requirement of limit. Minimum passing margin is -12.75dB at 19.476MHz.
15.247(a)(2)	Spectrum Bandwidth of a Direct Sequence Spread Spectrum System Limit : min. 500kHz	PASS	Meet the requirement of limit.
15.247(b)	Maximum Peak Output Power Limit: max. 30dBm	PASS	Meet the requirement of limit.
15.247(d)	Transmitter Radiated Emissions Limit: Table 15.209	PASS	Meet the requirement of limit. Minimum passing margin is -1.08dB at 2485.00MHz.
15.247(e)	Power Spectral Density Limit: max. 8dBm	PASS	Meet the requirement of limit.
15.247(d)	Band Edge Measurement Limit: 20dB less than the peak value of fundamental frequency	PASS	Meet the requirement of limit.

2.1 MEASUREMENT UNCERTAINTY

Where relevant, the following measurement uncertainty levels have been estimated for tests performed on the EUT as specified in CISPR 16-4:

MEASUREMENT	FREQUENCY	UNCERTAINTY
Conducted emissions	9kHz ~ 30MHz	2.44 dB
Radiated emissions	30MHz ~ 200MHz	3.71 dB
	200MHz ~ 1000MHz	3.73 dB
	1GHz ~ 18GHz	2.26 dB
	18GHz ~ 40GHz	1.94 dB

This uncertainty represents an expanded uncertainty expressed at approximately the 95% confidence level using a coverage factor of $k = 2$.



3. GENERAL INFORMATION

3.1 GENERAL DESCRIPTION OF EUT

PRODUCT	USRobotics Wireless Nd ₁ PCI Adapter
MODEL NO.	USR5419
FCC ID	MXF-P950622G
POWER SUPPLY	3.3Vdc from host equipment
MODULATION TYPE	CCK, DQPSK, DBPSK for DSSS 64QAM, 16QAM, QPSK, BPSK for OFDM
MODULATION TECHNOLOGY	DSSS, OFDM
TRANSFER RATE	802.11b: 11/ 5.5/ 2/ 1Mbps 802.11g: 54/ 48/ 36/ 24/ 18/ 12/ 9/ 6Mbps Draft 802.11n (20MHz): 130.0/ 117.0/ 104.0/ 78.0/ 52.0/ 39.0/ 26.0/ 13.0/ 65.0/ 58.5/ 52.0/ 29.0/ 26.0/ 19.5/ 13.0/ 6.5Mbps Draft 802.11n (40MHz): 270.0/ 243.0/ 216.0/ 162.0/ 108.0/ 81.0/ 54.0/27.0/ 135.0/121.5/ 108.0/ 81.0/ 54.0/ 40.5/ 27.0/ 13.5Mbps
FREQUENCY RANGE	2412MHz ~ 2462MHz
NUMBER OF CHANNEL	11 for 802.11b, 802.11g, draft 802.11n (20MHz) 7 for draft 802.11n (40MHz)
MAXIMUM OUTPUT POWER	160.151mW
ANTENNA TYPE	Dipole antenna with 2dBi gain
DATA CABLE	NA
I/O PORTS	NA

NOTE:

1. The EUT incorporates a MIMO function with 802.11b, 802.11g, draft 802.11n. Physically, the card provides two completed transmitters and two receivers.
2. The EUT is 2 * 2 spatial MIMO (2Tx & 2Rx) without beam forming function that only operate dual chain configuration (both chain 0 and chain 1 transceivers are operational).
3. When the EUT operating in 802.11b, 802.11g, the software operation, which is defined by manufacturer, only set single Tx.
4. When the EUT operating in draft 802.11n, the software operation, which is defined by manufacturer, only set 0 ~ 15 of "MCS" (MCS: Modulation and Coding Schemes) for dual Tx.
5. The EUT complies with draft 802.11n standards and backwards compatible with 802.11b, 802.11g products.
6. The EUT operates in the 2.4GHz frequency spectrum with throughput of up to 270Mbps.
7. The above EUT information was declared by manufacturer and for more detailed features description, please refer to the manufacturer's specifications or user's manual.

3.2 DESCRIPTION OF TEST MODES

Eleven channels are provided for 802.11b, 802.11g and draft 802.11n (20MHz):

CHANNEL	FREQUENCY	CHANNEL	FREQUENCY
1	2412MHz	7	2442MHz
2	2417MHz	8	2447MHz
3	2422MHz	9	2452MHz
4	2427MHz	10	2457MHz
5	2432MHz	11	2462MHz
6	2437MHz		

Seven channels are provided for draft 802.11n (40MHz):

CHANNEL	FREQUENCY	CHANNEL	FREQUENCY
1	2422MHz	5	2442MHz
2	2427MHz	6	2447MHz
3	2432MHz	7	2452MHz
4	2437MHz		

3.2.1 CONFIGURATION OF SYSTEM UNDER TEST

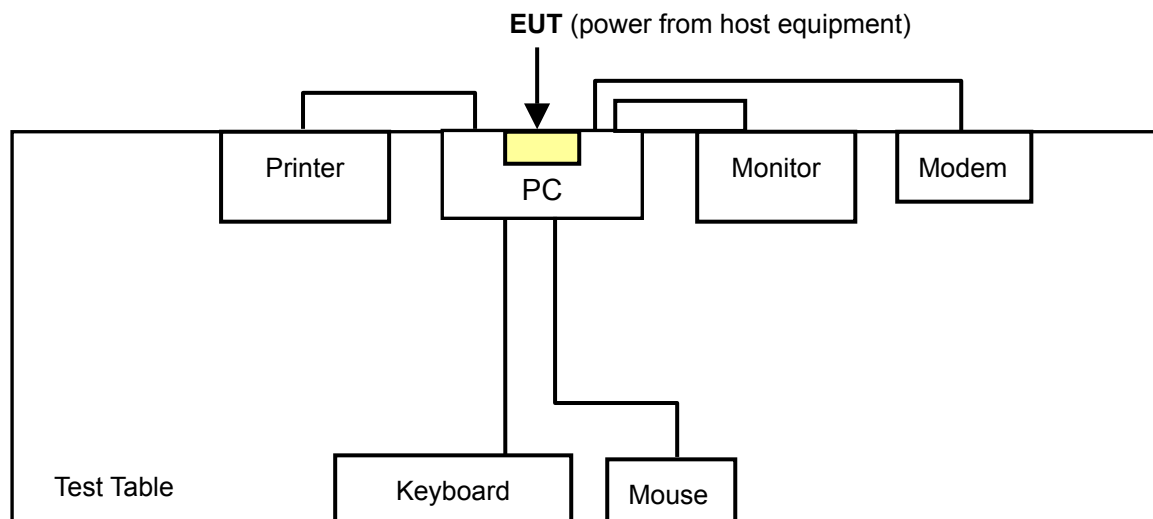

3.2.2 TEST MODE APPLICABILITY AND TESTED CHANNEL DETAIL

EUT CONFIGURE MODE	APPLICABLE TO				DESCRIPTION
	PLC	RE < 1G	RE ≥ 1G	APCM	
-	√	√	√	√	-

Where **PLC**: Power Line Conducted Emission **RE < 1G**: Radiated Emission below 1GHz
RE ≥ 1G: Radiated Emission above 1GHz **APCM**: Antenna Port Conducted Measurement

POWER LINE CONDUCTED EMISSION TEST:

- Pre-Scan has been conducted to determine the worst-case mode from all possible combinations between available modulations, data rates and antenna ports (if EUT with antenna diversity architecture).
- Following channel(s) was (were) selected for the final test as listed below.

MODE	AVAILABLE CHANNEL	TESTED CHANNEL	MODULATION TECHNOLOGY	MODULATION TYPE	DATA RATE (Mbps)	TX CONDITION
802.11g	1 to 11	1, 6, 11	OFDM	BPSK	6	Single
Draft 802.11n (20MHz)	1 to 11	1, 6, 11	OFDM	BPSK	6.5	Dual
Draft 802.11n (40MHz)	1 to 7	1, 4, 7	OFDM	BPSK	13.5	Dual

RADIATED EMISSION TEST (BELOW 1 GHz):

- Pre-Scan has been conducted to determine the worst-case mode from all possible combinations between available modulations, data rates and antenna ports (if EUT with antenna diversity architecture).
- Following channel(s) was (were) selected for the final test as listed below.

MODE	AVAILABLE CHANNEL	TESTED CHANNEL	MODULATION TECHNOLOGY	MODULATION TYPE	DATA RATE (Mbps)	TX CONDITION
802.11g	1 to 11	1	OFDM	BPSK	6	Single
Draft 802.11n (20MHz)	1 to 11	1	OFDM	BPSK	6.5	Dual
Draft 802.11n (40MHz)	1 to 7	1	OFDM	BPSK	13.5	Dual



RADIATED EMISSION TEST (ABOVE 1 GHz):

- Pre-Scan has been conducted to determine the worst-case mode from all possible combinations between available modulations, data rates and antenna ports (if EUT with antenna diversity architecture).
- Following channel(s) was (were) selected for the final test as listed below.

MODE	AVAILABLE CHANNEL	TESTED CHANNEL	MODULATION TECHNOLOGY	MODULATION TYPE	DATA RATE (Mbps)	TX CONDITION
802.11b	1 to 11	1, 6, 11	DSSS	DBPSK	1	Single
802.11g	1 to 11	1, 6, 11	OFDM	BPSK	6	Single
Draft 802.11n (20MHz)	1 to 11	1, 6, 11	OFDM	BPSK	6.5	Dual
Draft 802.11n (40MHz)	1 to 7	1, 4, 7	OFDM	BPSK	13.5	Dual

BANDEDGE MEASUREMENT:

- Pre-Scan has been conducted to determine the worst-case mode from all possible combinations between available modulations, data rates and antenna ports (if EUT with antenna diversity architecture).
- Following channel(s) was (were) selected for the final test as listed below.

MODE	AVAILABLE CHANNEL	TESTED CHANNEL	MODULATION TECHNOLOGY	MODULATION TYPE	DATA RATE (Mbps)	TX CONDITION
802.11b	1 to 11	1, 11	DSSS	DBPSK	1	Single
802.11g	1 to 11	1, 11	OFDM	BPSK	6	Single
Draft 802.11n (20MHz)	1 to 11	1, 11	OFDM	BPSK	6.5	Dual
Draft 802.11n (40MHz)	1 to 7	1, 7	OFDM	BPSK	13.5	Dual



ANTENNA PORT CONDUCTED MEASUREMENT:

- Pre-Scan has been conducted to determine the worst-case mode from all possible combinations between available modulations, data rates and antenna ports (if EUT with antenna diversity architecture).
- Following channel(s) was (were) selected for the final test as listed below.

MODE	AVAILABLE CHANNEL	TESTED CHANNEL	MODULATION TECHNOLOGY	MODULATION TYPE	DATA RATE (Mbps)	TX CONDITION
802.11b	1 to 11	1, 6, 11	DSSS	DBPSK	1	Single
802.11g	1 to 11	1, 6, 11	OFDM	BPSK	6	Single
Draft 802.11n (20MHz)	1 to 11	1, 6, 11	OFDM	BPSK	6.5	Dual
Draft 802.11n (40MHz)	1 to 7	1, 4, 7	OFDM	BPSK	13.5	Dual

3.3 GENERAL DESCRIPTION OF APPLIED STANDARDS

The EUT is a RF product. According to the specifications of the manufacturer, it must comply with the requirements of the following standards:

FCC Part 15, Subpart C. (15.247)

ANSI C63.4-2003

All test items have been performed and recorded as per the above standards.

NOTE: The EUT is also considered as a kind of computer peripheral, because the connection to computer is necessary for typical use. It has been verified to comply with the requirements of FCC Part 15, Subpart B, Class B (DoC). The test report has been issued separately.



3.4 DESCRIPTION OF SUPPORT UNITS

The EUT has been tested as an independent unit together with other necessary accessories or support units. The following support units or accessories were used to form a representative test configuration during the tests.

NO.	PRODUCT	BRAND	MODEL NO.	SERIAL NO.	FCC ID
1	PERSONAL COMPUTER	MSI	Hetis 865G	380125734	FCC DoC Approved
2	LCD MONITOR	COMPAQ	FP 5315	CNN3480KJR	FCC DoC Approved
3	PRINTER	EPSON	LQ-300+	DCGY047265	FCC DoC Approved
4	MODEM	ACEEX	1414V/3	0401008248	IFAXDM1414
5	KEYBOARD	DELL	SK-8110	MY-05N456-71619-3C1-1870	FCC DoC Approved
6	MOUSE	HP	M-S69	M4-010582	INZ211443

NO.	SIGNAL CABLE DESCRIPTION OF THE ABOVE SUPPORT UNITS
1	NA
2	1.8m shielded cable
3	1.6m shielded cable
4	1.6m shielded cable
5	1.2m shielded cable
6	1.2m shielded cable

NOTE: All power cords of the above support units are non shielded (1.8m).



4. TEST TYPES AND RESULTS

4.1 CONDUCTED EMISSION MEASUREMENT

4.1.1 LIMITS OF CONDUCTED EMISSION MEASUREMENT

FREQUENCY OF EMISSION (MHz)	CONDUCTED LIMIT (dB μ V)	
	Quasi-peak	Average
0.15-0.5	66 to 56	56 to 46
0.5-5	56	46
5-30	60	50

- NOTE:**
1. The lower limit shall apply at the transition frequencies.
 2. The limit decreases in line with the logarithm of the frequency in the range of 0.15 to 0.50 MHz.
 3. All emanations from a class A/B digital device or system, including any network of conductors and apparatus connected thereto, shall not exceed the level of field strengths specified above.

4.1.2 TEST INSTRUMENTS

DESCRIPTION & MANUFACTURER	MODEL NO.	SERIAL NO.	CALIBRATED UNTIL
Test Receiver ROHDE & SCHWARZ	ESCS30	100288	Nov. 02, 2006
RF signal cable Woken	5D-FB	Cable-HYCO3-01	Jan. 06, 2007
LISN ROHDE & SCHWARZ	ESH2-Z5	100100	Jan. 09, 2007
LISN ROHDE & SCHWARZ	ESH3-Z5	100311	Jan. 22, 2007
Software ADT	ADT_Cond_V3	NA	NA

- NOTE:**
1. The calibration interval of the above test instruments is 12 months and the calibrations are traceable to NML/ROC and NIST/USA.
 2. The test was performed in HwaYa Shielded Room 2.
 3. The VCCI Site Registration No. is C-2047.

4.1.3 TEST PROCEDURES

- a. The EUT was placed 0.4 meters from the conducting wall of the shielded room with EUT being connected to the power mains through a line impedance stabilization network (LISN). Other support units were connected to the power mains through another LISN. The two LISNs provide 50 ohm/ 50uH of coupling impedance for the measuring instrument.
- b. Both lines of the power mains connected to the EUT were checked for maximum conducted interference.
- c. The frequency range from 150kHz to 30MHz was searched. Emission levels under (Limit - 20dB) was not recorded.

4.1.4 DEVIATION FROM TEST STANDARD

No deviation

4.1.5 TEST SETUP

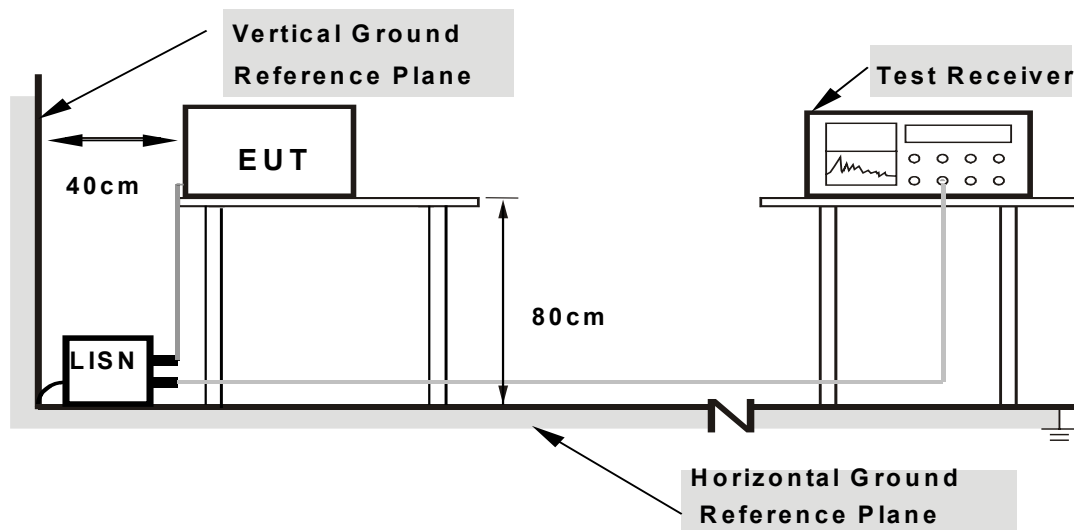

- Note:**
1. Support units were connected to second LISN.
 2. Both of LISNs (AMN) are 80 cm from EUT and at least 80 from other units and other metal planes

For the actual test configuration, please refer to the related item – Photographs of the Test Configuration.

4.1.6 EUT OPERATING CONDITIONS

- a. Connected the EUT to PC and placed on a testing table.
- b. The PC ran a test program to enable EUT under transmission/receiving condition continuously at specific channel frequency.
- c. The PC sent "H" messages to its screen.
- d. The PC sent "H" messages to modem.
- e. The PC sent "H" messages to printer and the printer prints them on paper.

4.1.7 TEST RESULTS

CONDUCTED WORST-CASE DATA:

802.11g OFDM MODULATION:

EUT TEST CONDITION		MEASUREMENT DETAIL	
CHANNEL	Channel 1	PHASE	Line 1
MODULATION TYPE	BPSK	6dB BANDWIDTH	9 kHz
TRANSFER RATE	6Mbps	INPUT POWER (SYSTEM)	120Vac, 60 Hz
ENVIRONMENTAL CONDITIONS	20deg. C, 60%RH, 991hPa	TESTED BY	Match Tsui

No	Freq. [MHz]	Corr. Factor (dB)	Reading Value [dB (uV)]		Emission Level [dB (uV)]		Limit [dB (uV)]		Margin (dB)	
			Q.P.	AV.	Q.P.	AV.	Q.P.	AV.	Q.P.	AV.
1	0.189	0.10	46.38	-	46.48	-	64.08	54.08	-17.60	-
2	0.255	0.10	39.83	-	39.93	-	61.58	51.58	-21.65	-
3	0.443	0.10	36.73	-	36.83	-	57.01	47.01	-20.18	-
4	1.523	0.15	35.39	-	35.54	-	56.00	46.00	-20.46	-
5	3.555	0.33	35.38	-	35.71	-	56.00	46.00	-20.29	-
6	19.878	0.56	42.07	-	42.63	-	60.00	50.00	-17.37	-

- REMARKS:**
1. Q.P. and AV. are abbreviations of quasi-peak and average individually.
 2. "-": The Quasi-peak reading value also meets average limit and measurement with the average detector is unnecessary.
 3. The emission levels of other frequencies were very low against the limit.
 4. Margin value = Emission level - Limit value
 5. Correction factor = Insertion loss + Cable loss
 6. Emission Level = Correction Factor + Reading Value.

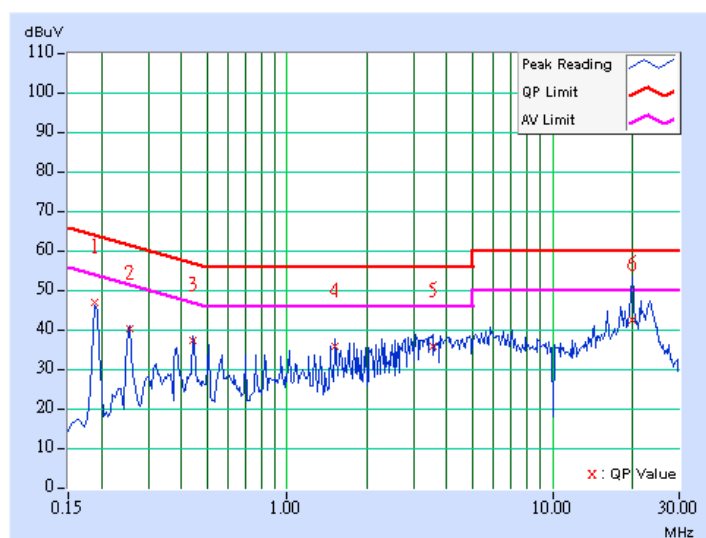

EUT TEST CONDITION		MEASUREMENT DETAIL	
CHANNEL	Channel 1	PHASE	Line 2
MODULATION TYPE	BPSK	6dB BANDWIDTH	9 kHz
TRANSFER RATE	6Mbps	INPUT POWER (SYSTEM)	120Vac, 60 Hz
ENVIRONMENTAL CONDITIONS	20deg. C, 60%RH, 991hPa	TESTED BY	Match Tsui

No	Freq. [MHz]	Corr. Factor (dB)	Reading Value [dB (uV)]		Emission Level [dB (uV)]		Limit [dB (uV)]		Margin (dB)	
			Q.P.	AV.	Q.P.	AV.	Q.P.	AV.	Q.P.	AV.
			1	0.189	0.10	46.66	-	46.76	-	64.08
2	0.380	0.10	41.03	-	41.13	-	58.27	48.27	-17.14	-
3	0.634	0.14	40.62	-	40.76	-	56.00	46.00	-15.24	-
4	1.203	0.20	38.51	-	38.71	-	56.00	46.00	-17.29	-
5	3.227	0.30	31.95	-	32.25	-	56.00	46.00	-23.75	-
6	19.459	0.57	35.18	-	35.75	-	60.00	50.00	-24.25	-

- REMARKS:**
1. Q.P. and AV. are abbreviations of quasi-peak and average individually.
 2. "-": The Quasi-peak reading value also meets average limit and measurement with the average detector is unnecessary.
 3. The emission levels of other frequencies were very low against the limit.
 4. Margin value = Emission level - Limit value
 5. Correction factor = Insertion loss + Cable loss
 6. Emission Level = Correction Factor + Reading Value.

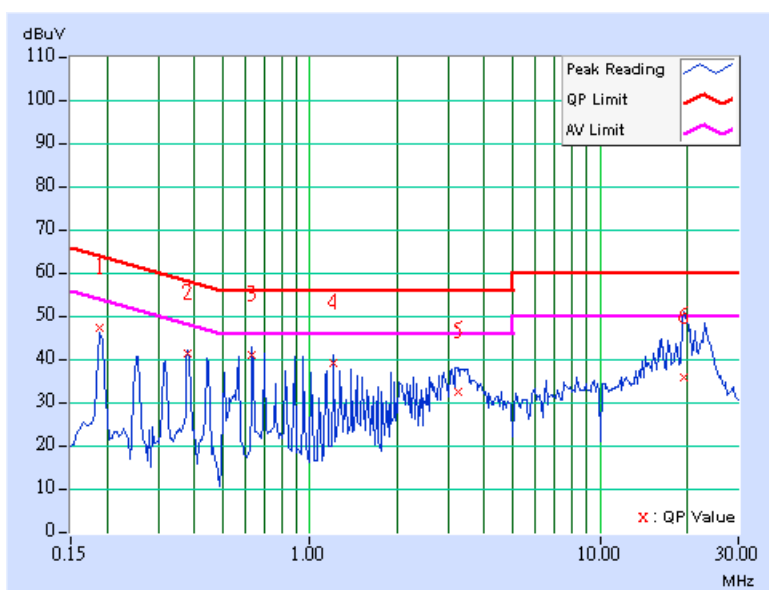

EUT TEST CONDITION		MEASUREMENT DETAIL	
CHANNEL	Channel 6	PHASE	Line 1
MODULATION TYPE	BPSK	6dB BANDWIDTH	9 kHz
TRANSFER RATE	6Mbps	INPUT POWER (SYSTEM)	120Vac, 60 Hz
ENVIRONMENTAL CONDITIONS	20deg. C, 60%RH, 991hPa	TESTED BY	Match Tsui

No	Freq. [MHz]	Corr. Factor (dB)	Reading Value [dB (uV)]		Emission Level [dB (uV)]		Limit [dB (uV)]		Margin (dB)	
			Q.P.	AV.	Q.P.	AV.	Q.P.	AV.	Q.P.	AV.
1	0.189	0.10	46.15	-	46.25	-	64.08	54.08	-17.83	-
2	0.255	0.10	40.05	-	40.15	-	61.58	51.58	-21.43	-
3	0.443	0.10	36.01	-	36.11	-	57.01	47.01	-20.90	-
4	1.781	0.18	36.37	-	36.55	-	56.00	46.00	-19.45	-
5	3.117	0.29	36.04	-	36.33	-	56.00	46.00	-19.67	-
6	19.476	0.57	46.68	-	47.25	-	60.00	50.00	-12.75	-

- REMARKS:**
1. Q.P. and AV. are abbreviations of quasi-peak and average individually.
 2. "-": The Quasi-peak reading value also meets average limit and measurement with the average detector is unnecessary.
 3. The emission levels of other frequencies were very low against the limit.
 4. Margin value = Emission level - Limit value
 5. Correction factor = Insertion loss + Cable loss
 6. Emission Level = Correction Factor + Reading Value.

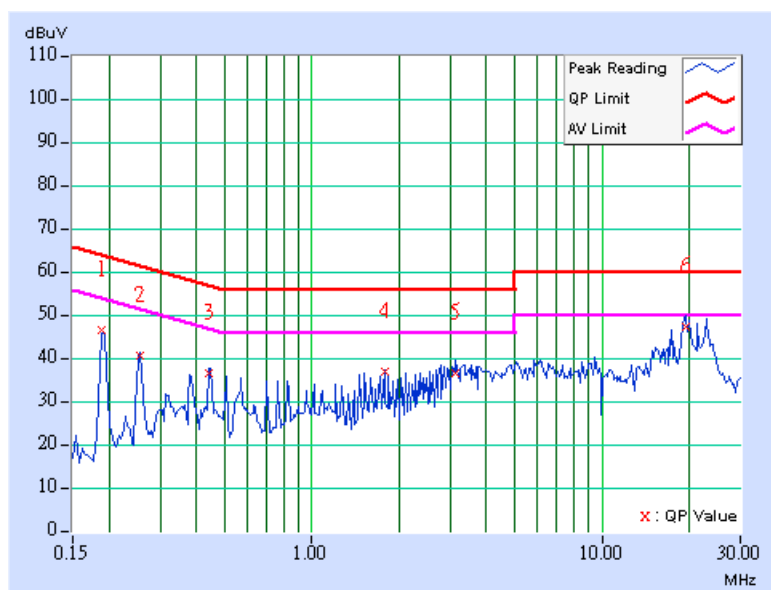

EUT TEST CONDITION		MEASUREMENT DETAIL	
CHANNEL	Channel 6	PHASE	Line 2
MODULATION TYPE	BPSK	6dB BANDWIDTH	9 kHz
TRANSFER RATE	6Mbps	INPUT POWER (SYSTEM)	120Vac, 60 Hz
ENVIRONMENTAL CONDITIONS	20deg. C, 60%RH, 991hPa	TESTED BY	Match Tsui

No	Freq. [MHz]	Corr. Factor (dB)	Reading Value [dB (uV)]		Emission Level [dB (uV)]		Limit [dB (uV)]		Margin (dB)	
			Q.P.	AV.	Q.P.	AV.	Q.P.	AV.	Q.P.	AV.
1	0.193	0.10	45.44	-	45.54	-	63.91	53.91	-18.37	-
2	0.318	0.10	40.07	-	40.17	-	59.76	49.76	-19.59	-
3	0.634	0.14	40.32	-	40.46	-	56.00	46.00	-15.54	-
4	0.892	0.18	39.30	-	39.48	-	56.00	46.00	-16.52	-
5	3.242	0.31	35.36	-	35.67	-	56.00	46.00	-20.33	-
6	19.261	0.57	41.61	-	42.18	-	60.00	50.00	-17.82	-

- REMARKS:**
1. Q.P. and AV. are abbreviations of quasi-peak and average individually.
 2. "-": The Quasi-peak reading value also meets average limit and measurement with the average detector is unnecessary.
 3. The emission levels of other frequencies were very low against the limit.
 4. Margin value = Emission level - Limit value
 5. Correction factor = Insertion loss + Cable loss
 6. Emission Level = Correction Factor + Reading Value.

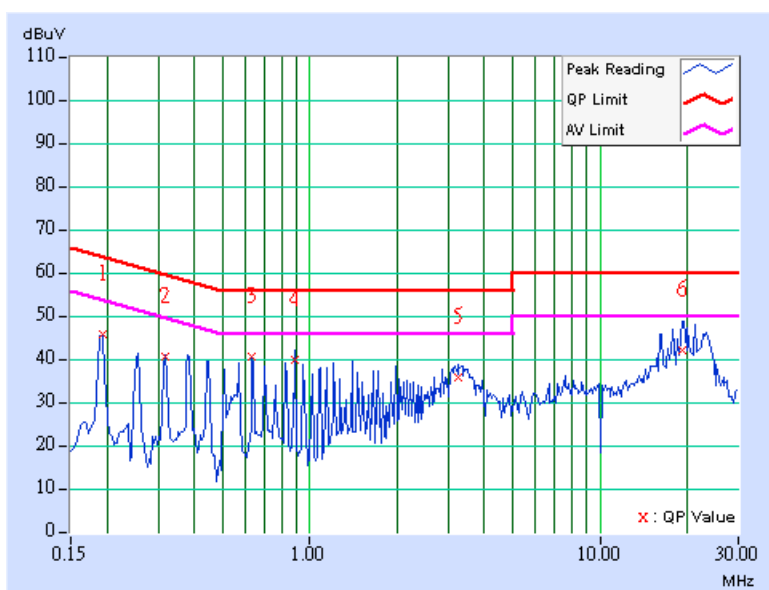

EUT TEST CONDITION		MEASUREMENT DETAIL	
CHANNEL	Channel 11	PHASE	Line 1
MODULATION TYPE	BPSK	6dB BANDWIDTH	9 kHz
TRANSFER RATE	6Mbps	INPUT POWER (SYSTEM)	120Vac, 60 Hz
ENVIRONMENTAL CONDITIONS	20deg. C, 60%RH, 991hPa	TESTED BY	Match Tsui

No	Freq. [MHz]	Corr. Factor (dB)	Reading Value [dB (uV)]		Emission Level [dB (uV)]		Limit [dB (uV)]		Margin (dB)	
			Q.P.	AV.	Q.P.	AV.	Q.P.	AV.	Q.P.	AV.
1	0.190	0.10	46.49	-	46.59	-	64.02	54.02	-17.43	-
2	0.255	0.10	40.03	-	40.13	-	61.58	51.58	-21.45	-
3	0.447	0.10	36.75	-	36.85	-	56.93	46.93	-20.08	-
4	0.763	0.10	33.54	-	33.64	-	56.00	46.00	-22.36	-
5	3.441	0.32	35.31	-	35.63	-	56.00	46.00	-20.37	-
6	19.504	0.57	41.24	-	41.81	-	60.00	50.00	-18.19	-

- REMARKS:**
1. Q.P. and AV. are abbreviations of quasi-peak and average individually.
 2. "-": The Quasi-peak reading value also meets average limit and measurement with the average detector is unnecessary.
 3. The emission levels of other frequencies were very low against the limit.
 4. Margin value = Emission level - Limit value
 5. Correction factor = Insertion loss + Cable loss
 6. Emission Level = Correction Factor + Reading Value.

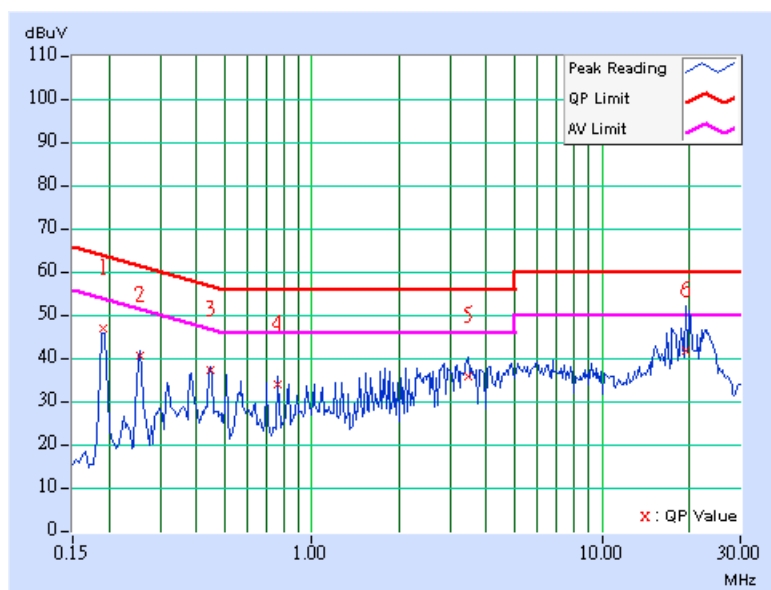

EUT TEST CONDITION		MEASUREMENT DETAIL	
CHANNEL	Channel 11	PHASE	Line 2
MODULATION TYPE	BPSK	6dB BANDWIDTH	9 kHz
TRANSFER RATE	6Mbps	INPUT POWER (SYSTEM)	120Vac, 60 Hz
ENVIRONMENTAL CONDITIONS	20deg. C, 60%RH, 991hPa	TESTED BY	Match Tsui

No	Freq. [MHz]	Corr. Factor (dB)	Reading Value [dB (uV)]		Emission Level [dB (uV)]		Limit [dB (uV)]		Margin (dB)	
			Q.P.	AV.	Q.P.	AV.	Q.P.	AV.	Q.P.	AV.
			1	0.189	0.10	46.42	-	46.52	-	64.08
2	0.380	0.10	40.03	-	40.13	-	58.27	48.27	-18.14	-
3	0.638	0.14	40.25	-	40.39	-	56.00	46.00	-15.61	-
4	0.892	0.18	40.23	-	40.41	-	56.00	46.00	-15.59	-
5	3.438	0.32	35.41	-	35.73	-	56.00	46.00	-20.27	-
6	19.491	0.57	42.55	-	43.12	-	60.00	50.00	-16.88	-

- REMARKS:**
1. Q.P. and AV. are abbreviations of quasi-peak and average individually.
 2. "-": The Quasi-peak reading value also meets average limit and measurement with the average detector is unnecessary.
 3. The emission levels of other frequencies were very low against the limit.
 4. Margin value = Emission level - Limit value
 5. Correction factor = Insertion loss + Cable loss
 6. Emission Level = Correction Factor + Reading Value.

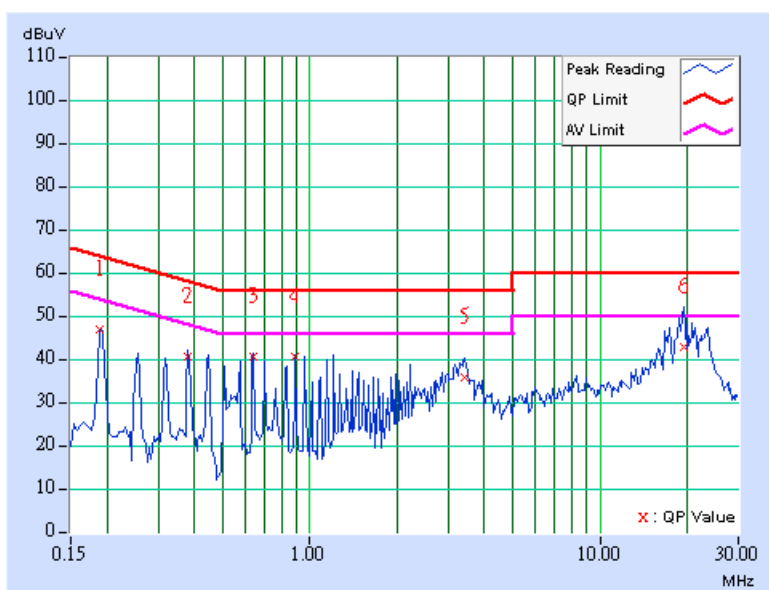

DRAFT 802.11n (20MHz) OFDM MODULATION:

EUT TEST CONDITION		MEASUREMENT DETAIL	
CHANNEL	Channel 1	PHASE	Line 1
MODULATION TYPE	BPSK	6dB BANDWIDTH	9 kHz
TRANSFER RATE	6.5Mbps	INPUT POWER (SYSTEM)	120Vac, 60 Hz
ENVIRONMENTAL CONDITIONS	20deg. C, 60%RH, 991hPa	TESTED BY	Match Tsui

No	Freq. [MHz]	Corr. Factor (dB)	Reading Value [dB (uV)]		Emission Level [dB (uV)]		Limit [dB (uV)]		Margin (dB)	
			Q.P.	AV.	Q.P.	AV.	Q.P.	AV.	Q.P.	AV.
1	0.193	0.10	45.98	-	46.08	-	63.91	53.91	-17.83	-
2	0.255	0.10	40.14	-	40.24	-	61.58	51.58	-21.34	-
3	0.447	0.10	36.90	-	37.00	-	56.93	46.93	-19.93	-
4	1.723	0.17	33.77	-	33.94	-	56.00	46.00	-22.06	-
5	3.125	0.30	35.76	-	36.06	-	56.00	46.00	-19.94	-
6	19.719	0.56	42.45	-	43.01	-	60.00	50.00	-16.99	-

- REMARKS:**
1. Q.P. and AV. are abbreviations of quasi-peak and average individually.
 2. "-": The Quasi-peak reading value also meets average limit and measurement with the average detector is unnecessary.
 3. The emission levels of other frequencies were very low against the limit.
 4. Margin value = Emission level - Limit value
 5. Correction factor = Insertion loss + Cable loss
 6. Emission Level = Correction Factor + Reading Value.

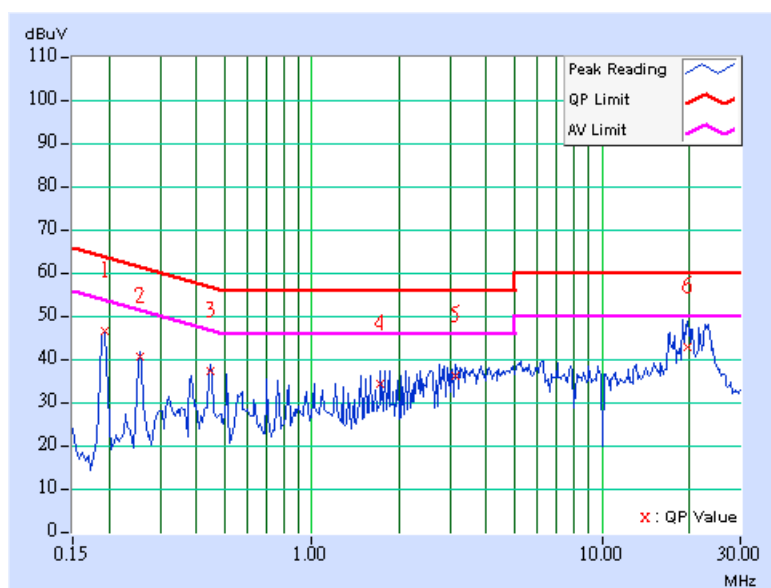

EUT TEST CONDITION		MEASUREMENT DETAIL	
CHANNEL	Channel 1	PHASE	Line 2
MODULATION TYPE	BPSK	6dB BANDWIDTH	9 kHz
TRANSFER RATE	6.5Mbps	INPUT POWER (SYSTEM)	120Vac, 60 Hz
ENVIRONMENTAL CONDITIONS	20deg. C, 60%RH, 991hPa	TESTED BY	Match Tsui

No	Freq.	Corr.	Reading Value		Emission Level		Limit		Margin	
	[MHz]	Factor	[dB (uV)]		[dB (uV)]		[dB (uV)]		(dB)	
		(dB)	Q.P.	AV.	Q.P.	AV.	Q.P.	AV.	Q.P.	AV.
1	0.193	0.10	45.88	-	45.98	-	63.91	53.91	-17.93	-
2	0.384	0.10	40.50	-	40.60	-	58.18	48.18	-17.58	-
3	0.638	0.14	40.79	-	40.93	-	56.00	46.00	-15.07	-
4	0.892	0.18	40.77	-	40.95	-	56.00	46.00	-15.05	-
5	3.188	0.30	36.68	-	36.98	-	56.00	46.00	-19.02	-
6	19.195	0.57	40.86	-	41.43	-	60.00	50.00	-18.57	-

- REMARKS:**
1. Q.P. and AV. are abbreviations of quasi-peak and average individually.
 2. "-": The Quasi-peak reading value also meets average limit and measurement with the average detector is unnecessary.
 3. The emission levels of other frequencies were very low against the limit.
 4. Margin value = Emission level - Limit value
 5. Correction factor = Insertion loss + Cable loss
 6. Emission Level = Correction Factor + Reading Value.

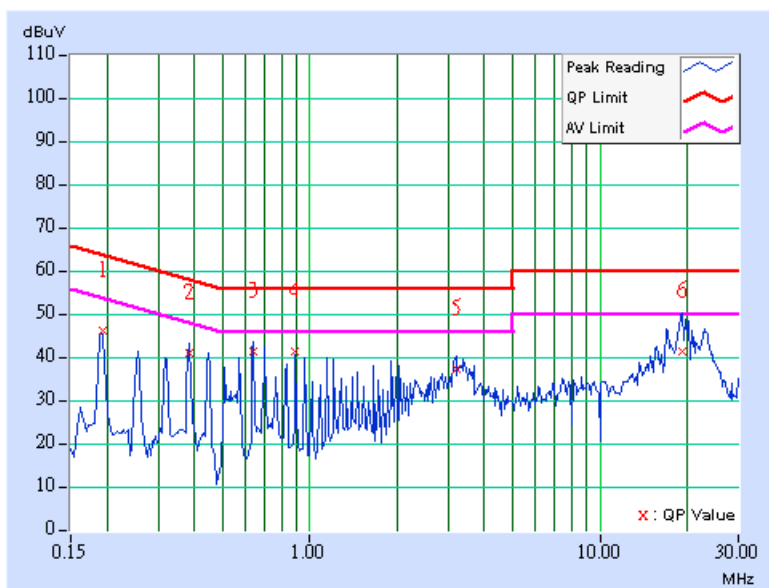

EUT TEST CONDITION		MEASUREMENT DETAIL	
CHANNEL	Channel 6	PHASE	Line 1
MODULATION TYPE	BPSK	6dB BANDWIDTH	9 kHz
TRANSFER RATE	6.5Mbps	INPUT POWER (SYSTEM)	120Vac, 60 Hz
ENVIRONMENTAL CONDITIONS	20deg. C, 60%RH, 991hPa	TESTED BY	Match Tsui

No	Freq. [MHz]	Corr. Factor (dB)	Reading Value [dB (uV)]		Emission Level [dB (uV)]		Limit [dB (uV)]		Margin (dB)	
			Q.P.	AV.	Q.P.	AV.	Q.P.	AV.	Q.P.	AV.
1	0.193	0.10	46.14	-	46.24	-	63.91	53.91	-17.67	-
2	0.255	0.10	40.20	-	40.30	-	61.58	51.58	-21.28	-
3	0.447	0.10	37.00	-	37.10	-	56.93	46.93	-19.83	-
4	1.789	0.18	36.37	-	36.55	-	56.00	46.00	-19.45	-
5	3.512	0.33	35.53	-	35.86	-	56.00	46.00	-20.14	-
6	19.799	0.56	43.26	-	43.82	-	60.00	50.00	-16.18	-

- REMARKS:**
1. Q.P. and AV. are abbreviations of quasi-peak and average individually.
 2. "-": The Quasi-peak reading value also meets average limit and measurement with the average detector is unnecessary.
 3. The emission levels of other frequencies were very low against the limit.
 4. Margin value = Emission level - Limit value
 5. Correction factor = Insertion loss + Cable loss
 6. Emission Level = Correction Factor + Reading Value.

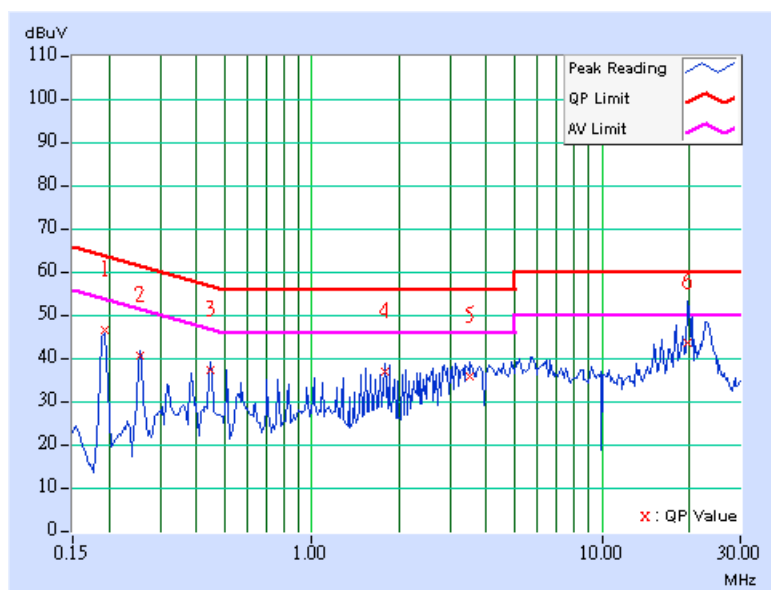

EUT TEST CONDITION		MEASUREMENT DETAIL	
CHANNEL	Channel 6	PHASE	Line 2
MODULATION TYPE	BPSK	6dB BANDWIDTH	9 kHz
TRANSFER RATE	6.5Mbps	INPUT POWER (SYSTEM)	120Vac, 60 Hz
ENVIRONMENTAL CONDITIONS	20deg. C, 60%RH, 991hPa	TESTED BY	Match Tsui

No	Freq. [MHz]	Corr. Factor (dB)	Reading Value [dB (uV)]		Emission Level [dB (uV)]		Limit [dB (uV)]		Margin (dB)	
			Q.P.	AV.	Q.P.	AV.	Q.P.	AV.	Q.P.	AV.
			1	0.193	0.10	45.92	-	46.02	-	63.91
2	0.384	0.10	40.48	-	40.58	-	58.18	48.18	-17.60	-
3	0.638	0.14	40.87	-	41.01	-	56.00	46.00	-14.99	-
4	0.959	0.19	39.27	-	39.46	-	56.00	46.00	-16.54	-
5	3.191	0.30	36.86	-	37.16	-	56.00	46.00	-18.84	-
6	19.984	0.56	42.58	-	43.14	-	60.00	50.00	-16.86	-

- REMARKS:**
1. Q.P. and AV. are abbreviations of quasi-peak and average individually.
 2. "-": The Quasi-peak reading value also meets average limit and measurement with the average detector is unnecessary.
 3. The emission levels of other frequencies were very low against the limit.
 4. Margin value = Emission level - Limit value
 5. Correction factor = Insertion loss + Cable loss
 6. Emission Level = Correction Factor + Reading Value.

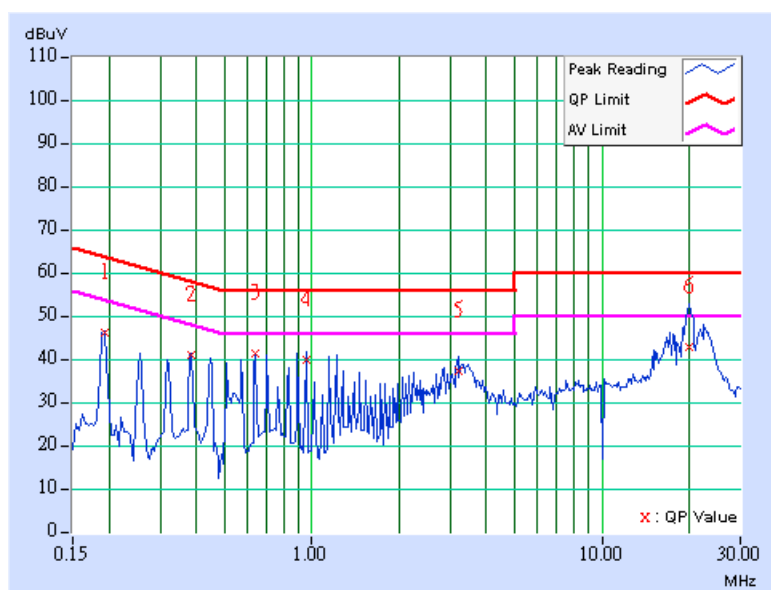

EUT TEST CONDITION		MEASUREMENT DETAIL	
CHANNEL	Channel 11	PHASE	Line 1
MODULATION TYPE	BPSK	6dB BANDWIDTH	9 kHz
TRANSFER RATE	6.5Mbps	INPUT POWER (SYSTEM)	120Vac, 60 Hz
ENVIRONMENTAL CONDITIONS	20deg. C, 60%RH, 991hPa	TESTED BY	Match Tsui

No	Freq. [MHz]	Corr. Factor (dB)	Reading Value [dB (uV)]		Emission Level [dB (uV)]		Limit [dB (uV)]		Margin (dB)	
			Q.P.	AV.	Q.P.	AV.	Q.P.	AV.	Q.P.	AV.
1	0.193	0.10	46.39	-	46.49	-	63.91	53.91	-17.42	-
2	0.255	0.10	40.22	-	40.32	-	61.58	51.58	-21.26	-
3	0.447	0.10	36.63	-	36.73	-	56.93	46.93	-20.20	-
4	1.793	0.18	36.65	-	36.83	-	56.00	46.00	-19.17	-
5	3.206	0.30	36.08	-	36.38	-	56.00	46.00	-19.62	-
6	19.544	0.57	39.76	-	40.33	-	60.00	50.00	-19.67	-

- REMARKS:**
1. Q.P. and AV. are abbreviations of quasi-peak and average individually.
 2. "-": The Quasi-peak reading value also meets average limit and measurement with the average detector is unnecessary.
 3. The emission levels of other frequencies were very low against the limit.
 4. Margin value = Emission level - Limit value
 5. Correction factor = Insertion loss + Cable loss
 6. Emission Level = Correction Factor + Reading Value.

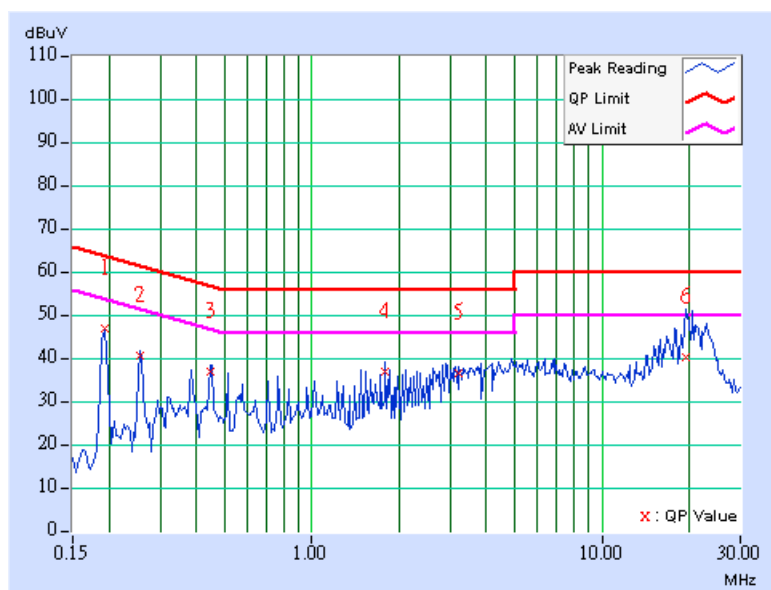

EUT TEST CONDITION		MEASUREMENT DETAIL	
CHANNEL	Channel 11	PHASE	Line 2
MODULATION TYPE	BPSK	6dB BANDWIDTH	9 kHz
TRANSFER RATE	6.5Mbps	INPUT POWER (SYSTEM)	120Vac, 60 Hz
ENVIRONMENTAL CONDITIONS	20deg. C, 60%RH, 991hPa	TESTED BY	Match Tsui

No	Freq. [MHz]	Corr. Factor (dB)	Reading Value [dB (uV)]		Emission Level [dB (uV)]		Limit [dB (uV)]		Margin (dB)	
			Q.P.	AV.	Q.P.	AV.	Q.P.	AV.	Q.P.	AV.
1	0.193	0.10	45.33	-	45.43	-	63.91	53.91	-18.48	-
2	0.384	0.10	41.35	-	41.45	-	58.18	48.18	-16.73	-
3	0.642	0.14	40.60	-	40.74	-	56.00	46.00	-15.26	-
4	1.215	0.20	38.19	-	38.39	-	56.00	46.00	-17.61	-
5	3.395	0.32	36.45	-	36.77	-	56.00	46.00	-19.23	-
6	20.566	0.59	42.42	-	43.01	-	60.00	50.00	-16.99	-

- REMARKS:**
1. Q.P. and AV. are abbreviations of quasi-peak and average individually.
 2. "-": The Quasi-peak reading value also meets average limit and measurement with the average detector is unnecessary.
 3. The emission levels of other frequencies were very low against the limit.
 4. Margin value = Emission level - Limit value
 5. Correction factor = Insertion loss + Cable loss
 6. Emission Level = Correction Factor + Reading Value.

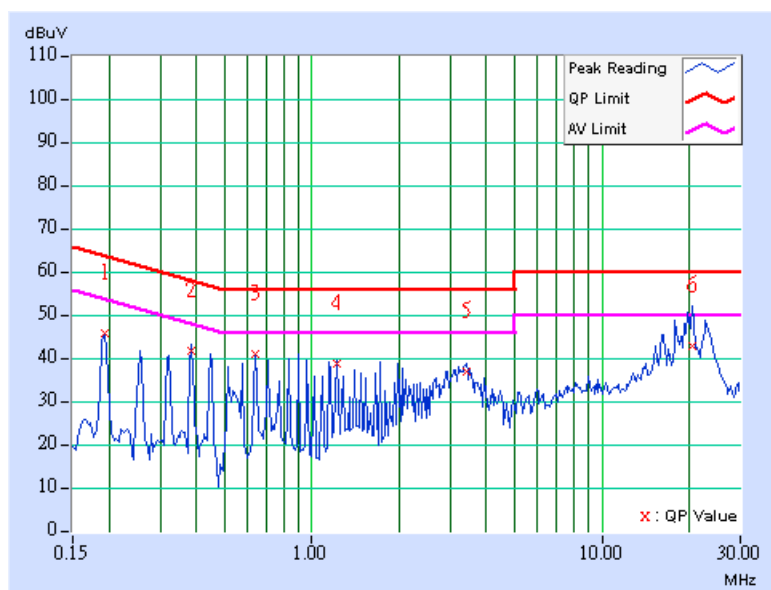

DRAFT 802.11n (40MHz) OFDM MODULATION:

EUT TEST CONDITION		MEASUREMENT DETAIL	
CHANNEL	Channel 1	PHASE	Line 1
MODULATION TYPE	BPSK	6dB BANDWIDTH	9 kHz
TRANSFER RATE	13.5Mbps	INPUT POWER (SYSTEM)	120Vac, 60 Hz
ENVIRONMENTAL CONDITIONS	20deg. C, 60%RH, 991hPa	TESTED BY	Match Tsui

No	Freq. [MHz]	Corr. Factor (dB)	Reading Value [dB (uV)]		Emission Level [dB (uV)]		Limit [dB (uV)]		Margin (dB)	
			Q.P.	AV.	Q.P.	AV.	Q.P.	AV.	Q.P.	AV.
1	0.193	0.10	46.47	-	46.57	-	63.91	53.91	-17.34	-
2	0.255	0.10	40.14	-	40.24	-	61.58	51.58	-21.34	-
3	0.447	0.10	36.45	-	36.55	-	56.93	46.93	-20.38	-
4	1.797	0.18	36.13	-	36.31	-	56.00	46.00	-19.69	-
5	3.078	0.29	36.06	-	36.35	-	56.00	46.00	-19.65	-
6	20.064	0.56	42.86	-	43.42	-	60.00	50.00	-16.58	-

- REMARKS:**
1. Q.P. and AV. are abbreviations of quasi-peak and average individually.
 2. "-": The Quasi-peak reading value also meets average limit and measurement with the average detector is unnecessary.
 3. The emission levels of other frequencies were very low against the limit.
 4. Margin value = Emission level - Limit value
 5. Correction factor = Insertion loss + Cable loss
 6. Emission Level = Correction Factor + Reading Value.

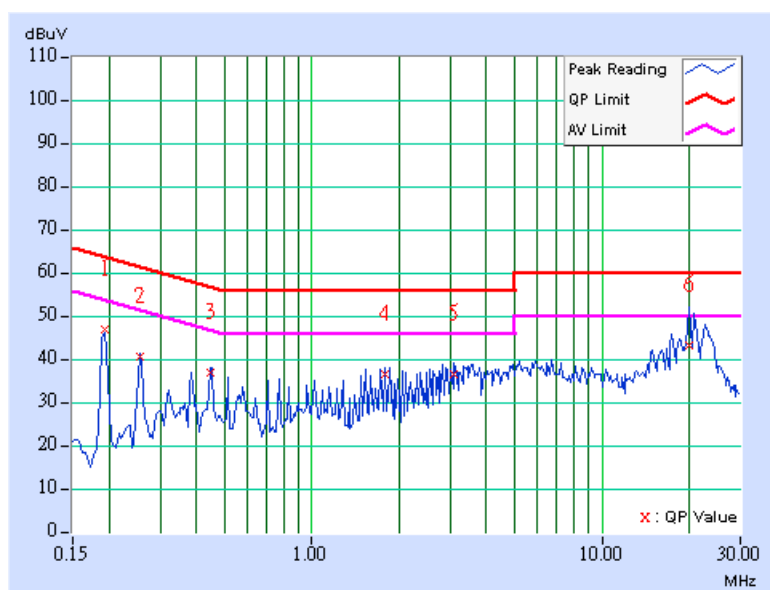

EUT TEST CONDITION		MEASUREMENT DETAIL	
CHANNEL	Channel 1	PHASE	Line 2
MODULATION TYPE	BPSK	6dB BANDWIDTH	9 kHz
TRANSFER RATE	13.5Mbps	INPUT POWER (SYSTEM)	120Vac, 60 Hz
ENVIRONMENTAL CONDITIONS	20deg. C, 60%RH, 991hPa	TESTED BY	Match Tsui

No	Freq.	Corr.	Reading Value		Emission Level		Limit		Margin	
	[MHz]	Factor	[dB (uV)]		[dB (uV)]		[dB (uV)]		(dB)	
		(dB)	Q.P.	AV.	Q.P.	AV.	Q.P.	AV.	Q.P.	AV.
1	0.193	0.10	46.12	-	46.22	-	63.91	53.91	-17.69	-
2	0.384	0.10	40.97	-	41.07	-	58.18	48.18	-17.11	-
3	0.642	0.14	40.75	-	40.89	-	56.00	46.00	-15.11	-
4	1.984	0.20	35.28	-	35.48	-	56.00	46.00	-20.52	-
5	3.398	0.32	36.19	-	36.51	-	56.00	46.00	-19.49	-
6	20.573	0.59	41.39	-	41.98	-	60.00	50.00	-18.02	-

- REMARKS:**
1. Q.P. and AV. are abbreviations of quasi-peak and average individually.
 2. "-": The Quasi-peak reading value also meets average limit and measurement with the average detector is unnecessary.
 3. The emission levels of other frequencies were very low against the limit.
 4. Margin value = Emission level - Limit value
 5. Correction factor = Insertion loss + Cable loss
 6. Emission Level = Correction Factor + Reading Value.

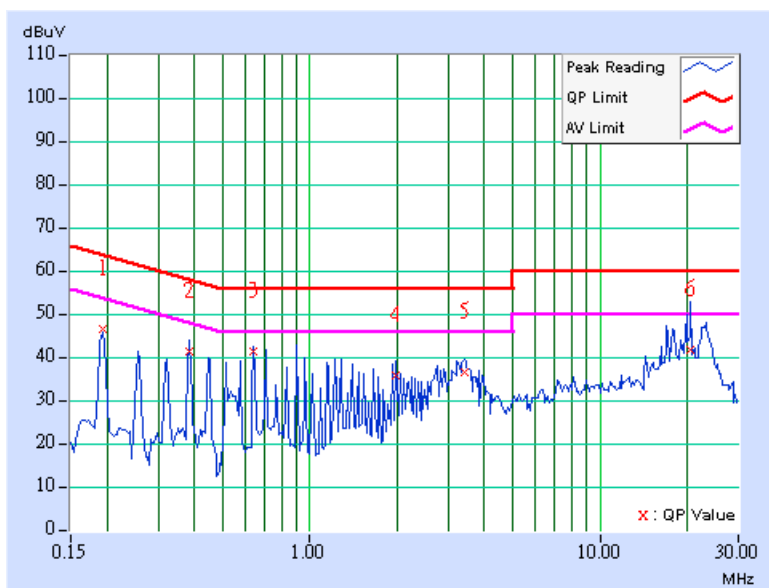

EUT TEST CONDITION		MEASUREMENT DETAIL	
CHANNEL	Channel 4	PHASE	Line 1
MODULATION TYPE	BPSK	6dB BANDWIDTH	9 kHz
TRANSFER RATE	13.5Mbps	INPUT POWER (SYSTEM)	120Vac, 60 Hz
ENVIRONMENTAL CONDITIONS	20deg. C, 60%RH, 991hPa	TESTED BY	Match Tsui

No	Freq. [MHz]	Corr. Factor (dB)	Reading Value [dB (uV)]		Emission Level [dB (uV)]		Limit [dB (uV)]		Margin (dB)	
			Q.P.	AV.	Q.P.	AV.	Q.P.	AV.	Q.P.	AV.
			1	0.193	0.10	46.49	-	46.59	-	63.91
2	0.255	0.10	40.14	-	40.24	-	61.58	51.58	-21.34	-
3	0.451	0.10	36.50	-	36.60	-	56.86	46.86	-20.26	-
4	1.797	0.18	36.47	-	36.65	-	56.00	46.00	-19.35	-
5	2.887	0.28	36.99	-	37.27	-	56.00	46.00	-18.73	-
6	19.559	0.57	42.64	-	43.21	-	60.00	50.00	-16.79	-

- REMARKS:**
1. Q.P. and AV. are abbreviations of quasi-peak and average individually.
 2. "-": The Quasi-peak reading value also meets average limit and measurement with the average detector is unnecessary.
 3. The emission levels of other frequencies were very low against the limit.
 4. Margin value = Emission level - Limit value
 5. Correction factor = Insertion loss + Cable loss
 6. Emission Level = Correction Factor + Reading Value.

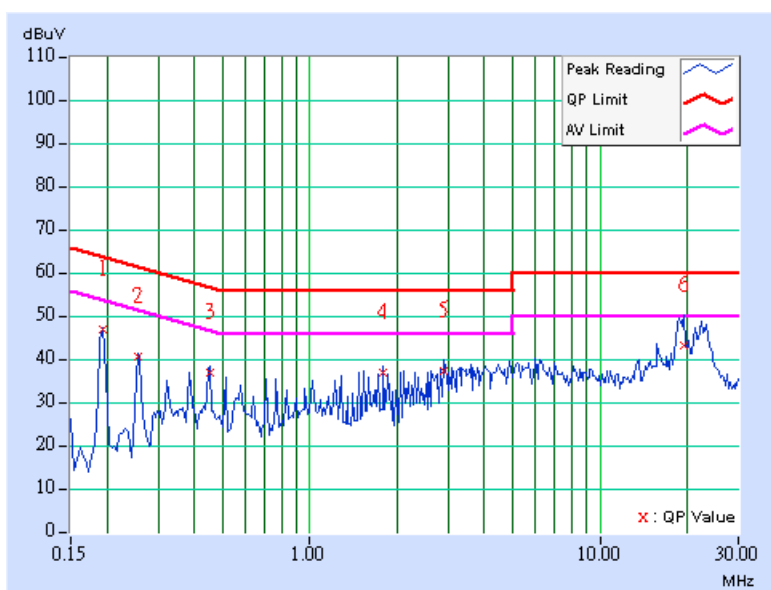

EUT TEST CONDITION		MEASUREMENT DETAIL	
CHANNEL	Channel 4	PHASE	Line 2
MODULATION TYPE	BPSK	6dB BANDWIDTH	9 kHz
TRANSFER RATE	13.5Mbps	INPUT POWER (SYSTEM)	120Vac, 60 Hz
ENVIRONMENTAL CONDITIONS	20deg. C, 60%RH, 991hPa	TESTED BY	Match Tsui

No	Freq.	Corr.	Reading Value		Emission Level		Limit		Margin	
	[MHz]	(dB)	[dB (uV)]		[dB (uV)]		[dB (uV)]		(dB)	
			Q.P.	AV.	Q.P.	AV.	Q.P.	AV.	Q.P.	AV.
1	0.193	0.10	46.18	-	46.28	-	63.91	53.91	-17.63	-
2	0.384	0.10	41.09	-	41.19	-	58.18	48.18	-16.99	-
3	0.447	0.11	40.25	-	40.36	-	56.93	46.93	-16.58	-
4	1.988	0.20	35.54	-	35.74	-	56.00	46.00	-20.26	-
5	3.398	0.32	36.31	-	36.63	-	56.00	46.00	-19.37	-
6	19.426	0.57	42.21	-	42.78	-	60.00	50.00	-17.22	-

- REMARKS:**
1. Q.P. and AV. are abbreviations of quasi-peak and average individually.
 2. "-": The Quasi-peak reading value also meets average limit and measurement with the average detector is unnecessary.
 3. The emission levels of other frequencies were very low against the limit.
 4. Margin value = Emission level - Limit value
 5. Correction factor = Insertion loss + Cable loss
 6. Emission Level = Correction Factor + Reading Value.

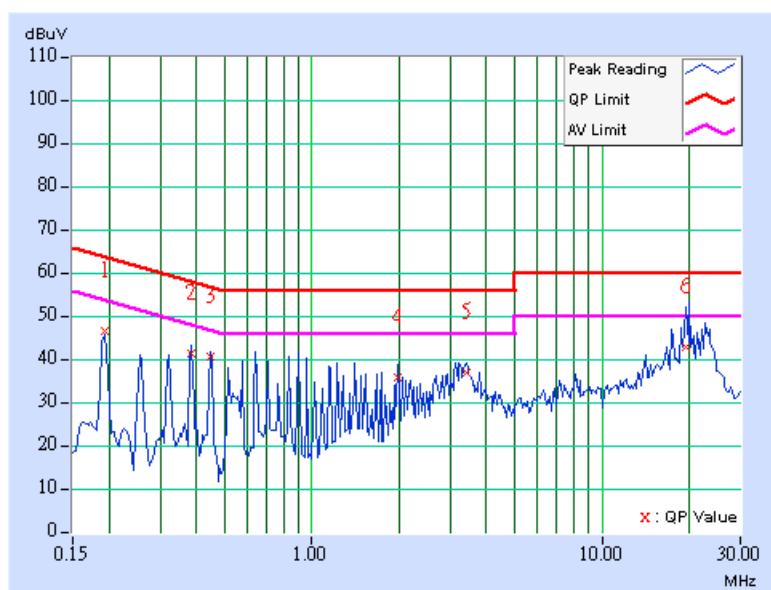

EUT TEST CONDITION		MEASUREMENT DETAIL	
CHANNEL	Channel 7	PHASE	Line 1
MODULATION TYPE	BPSK	6dB BANDWIDTH	9 kHz
TRANSFER RATE	13.5Mbps	INPUT POWER (SYSTEM)	120Vac, 60 Hz
ENVIRONMENTAL CONDITIONS	20deg. C, 60%RH, 991hPa	TESTED BY	Match Tsui

No	Freq. [MHz]	Corr. Factor (dB)	Reading Value [dB (uV)]		Emission Level [dB (uV)]		Limit [dB (uV)]		Margin (dB)	
			Q.P.	AV.	Q.P.	AV.	Q.P.	AV.	Q.P.	AV.
			1	0.193	0.10	46.49	-	46.59	-	63.91
2	0.255	0.10	40.28	-	40.38	-	61.58	51.58	-21.20	-
3	0.447	0.10	36.33	-	36.43	-	56.93	46.93	-20.50	-
4	1.539	0.15	36.28	-	36.43	-	56.00	46.00	-19.57	-
5	3.398	0.32	36.01	-	36.33	-	56.00	46.00	-19.67	-
6	20.010	0.56	43.03	-	43.59	-	60.00	50.00	-16.41	-

- REMARKS:**
1. Q.P. and AV. are abbreviations of quasi-peak and average individually.
 2. "-": The Quasi-peak reading value also meets average limit and measurement with the average detector is unnecessary.
 3. The emission levels of other frequencies were very low against the limit.
 4. Margin value = Emission level - Limit value
 5. Correction factor = Insertion loss + Cable loss
 6. Emission Level = Correction Factor + Reading Value.

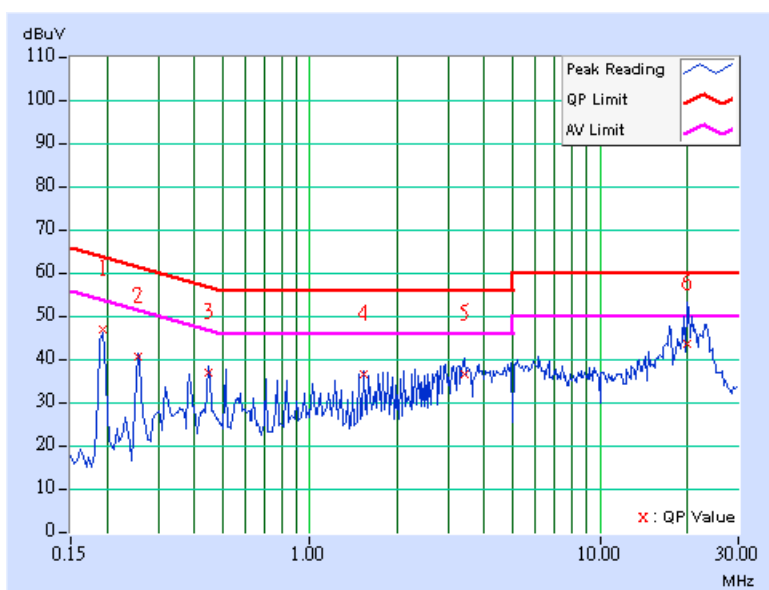

EUT TEST CONDITION		MEASUREMENT DETAIL	
CHANNEL	Channel 7	PHASE	Line 2
MODULATION TYPE	BPSK	6dB BANDWIDTH	9 kHz
TRANSFER RATE	13.5Mbps	INPUT POWER (SYSTEM)	120Vac, 60 Hz
ENVIRONMENTAL CONDITIONS	20deg. C, 60%RH, 991hPa	TESTED BY	Match Tsui

No	Freq. [MHz]	Corr. Factor (dB)	Reading Value [dB (uV)]		Emission Level [dB (uV)]		Limit [dB (uV)]		Margin (dB)	
			Q.P.	AV.	Q.P.	AV.	Q.P.	AV.	Q.P.	AV.
			1	0.193	0.10	45.41	-	45.51	-	63.91
2	0.384	0.10	41.35	-	41.45	-	58.18	48.18	-16.73	-
3	0.642	0.14	40.58	-	40.72	-	56.00	46.00	-15.28	-
4	1.219	0.20	40.92	-	41.12	-	56.00	46.00	-14.88	-
5	3.402	0.32	35.50	-	35.82	-	56.00	46.00	-20.18	-
6	19.879	0.56	44.36	-	44.92	-	60.00	50.00	-15.08	-

- REMARKS:**
1. Q.P. and AV. are abbreviations of quasi-peak and average individually.
 2. "-": The Quasi-peak reading value also meets average limit and measurement with the average detector is unnecessary.
 3. The emission levels of other frequencies were very low against the limit.
 4. Margin value = Emission level - Limit value
 5. Correction factor = Insertion loss + Cable loss
 6. Emission Level = Correction Factor + Reading Value.

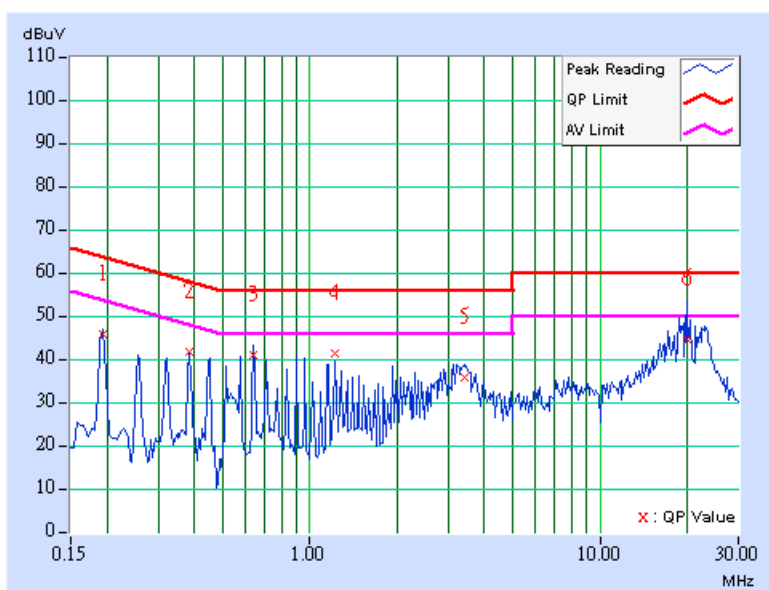

4.2 RADIATED EMISSION MEASUREMENT

4.2.1 LIMITS OF RADIATED EMISSION MEASUREMENT

Emissions radiated outside of the specified bands, shall be according to the general radiated limits in 15.209 as following:

FREQUENCIES (MHz)	FIELD STRENGTH (microvolts/meter)	MEASUREMENT DISTANCE (meters)
0.009 ~ 0.490	2400 / F(kHz)	300
0.490 ~ 1.705	24000 / F(kHz)	30
1.705 ~ 30.0	30	30
30 ~ 88	100	3
88 ~ 216	150	3
216 ~ 960	200	3
Above 960	500	3

NOTE:

1. The lower limit shall apply at the transition frequencies.
2. Emission level (dBuV/m) = 20 log Emission level (uV/m).
3. As shown in 15.35(b), for frequencies above 1000MHz, the field strength limits are based on average detector, however, the peak field strength of any emission shall not exceed the maximum permitted average limits, specified above by more than 20dB under any condition of modulation.



4.2.2 TEST INSTRUMENTS

DESCRIPTION & MANUFACTURER	MODEL NO.	SERIAL NO.	CALIBRATED UNTIL
Test Receiver ROHDE & SCHWARZ	ESI7	100033	May. 22, 2007
Spectrum Analyzer ROHDE & SCHWARZ	FSP40	100025	Dec. 05, 2006
BILOG Antenna SCHWARZBECK	VULB9168	9168-160	May 31, 2007
HORN Antenna SCHWARZBECK	9120D	9120D-408	Jan. 08, 2007
HORN Antenna SCHWARZBECK	BBHA 9170	BBHA9170243	Jan. 19, 2007
Preamplifier Agilent	8447D	2944A10633	Nov. 04, 2006
Preamplifier Agilent	8449B	3008A01964	Oct. 30, 2006
RF signal cable HUBER+SUHNNER	SUCOFLEX 104	214377/4	Dec. 13, 2006
RF signal cable HUBER+SUHNNER	SUCOFLEX 104	219272/4	Dec. 13, 2006
Software ADT.	ADT_Radiated_V5.14	NA	NA
Antenna Tower inn-co GmbH	MA 4000	013303	NA
Antenna Tower Controller inn-co GmbH	CO2000	017303	NA
Turn Table ADT.	TT100.	TT93021703	NA
Turn Table Controller ADT.	SC100.	SC93021703	NA

- NOTE:**
1. The calibration interval of the above test instruments is 12 months and the calibrations are traceable to NML/ROC and NIST/USA.
 2. The test was performed in HwaYa Chamber 3.
 3. The horn antenna and HP preamplifier (model: 8449B) are used only for the measurement of emission frequency above 1GHz if tested.
 4. The VCCI Site Registration No. is R-237.
 5. The IC Site Registration No. is IC4924-3.

4.2.3 TEST PROCEDURES

- a. The EUT was placed on the top of a rotating table 0.8 meters above the ground at a 3 meters semi-anechoic chamber. The table was rotated 360 degrees to determine the position of the highest radiation.
- b. The EUT was set 3 meters away from the interference-receiving antenna, which was mounted on the top of a variable-height antenna tower.
- c. The antenna is a broadband antenna, and its height is varied from one meter to four meters above the ground to determine the maximum value of the field strength. Both horizontal and vertical polarizations of the antenna are set to make the measurement.
- d. For each suspected emission, the EUT was arranged to its worst case and then the antenna was tuned to heights from 1 meter to 4 meters and the rotatable table was turned from 0 degrees to 360 degrees to find the maximum reading.
- e. The test-receiver system was set to Peak Detect Function and Specified Bandwidth with Maximum Hold Mode.
- f. If the emission level of the EUT in peak mode was lower than the limit specified, then testing could be stopped and the peak values of the EUT would be reported. Otherwise the emissions would be re-tested one by one using peak, quasi-peak or average method as specified and then reported in a data sheet.

NOTE:

1. The resolution bandwidth and video bandwidth of test receiver/spectrum analyzer is 120kHz for Peak detection (PK) and Quasi-peak detection (QP) at frequency below 1GHz.
2. The resolution bandwidth of test receiver/spectrum analyzer is 1 MHz and video bandwidth is 3MHz for Peak detection at frequency above 1GHz.
3. The resolution bandwidth of test receiver/spectrum analyzer is 1MHz and the video bandwidth is 10Hz for Average detection (AV) at frequency above 1GHz.

4.2.4 DEVIATION FROM TEST STANDARD

No deviation

4.2.5 TEST SETUP

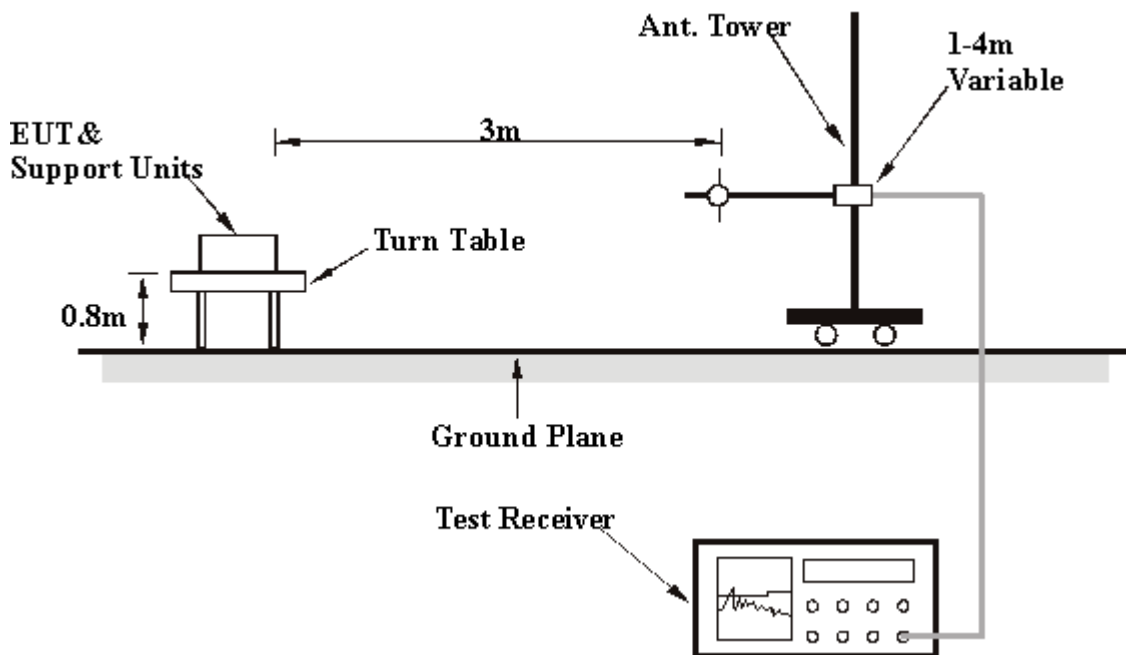

For the actual test configuration, please refer to the related item – Photographs of the Test Configuration.

4.2.6 EUT OPERATING CONDITIONS

Same as 4.1.6

4.2.7 TEST RESULTS

BELOW 1GHz WORST-CASE DATA

802.11g OFDM MODULATION:

EUT TEST CONDITION		MEASUREMENT DETAIL	
CHANNEL	Channel 1	FREQUENCY RANGE	Below 1000MHz
MODULATION TYPE	BPSK for 802.11g	INPUT POWER (SYSTEM)	120Vac, 60 Hz
TRANSFER RATE	6Mbps	DETECTOR FUNCTION	Quasi-Peak
ENVIRONMENTAL CONDITIONS	25deg. C, 68%RH, 991hPa	TESTED BY	Morgan Chen

ANTENNA POLARITY & TEST DISTANCE: HORIZONTAL AT 3 M								
No.	Freq. (MHz)	Emission Level (dBuV/m)	Limit (dBuV/m)	Margin (dB)	Antenna Height (m)	Table Angle (Degree)	Raw Value (dBuV)	Correction Factor (dB/m)
1	475.15	40.53 QP	46.00	-5.47	1.25 H	193	20.74	19.78
2	607.33	35.85 QP	46.00	-10.15	1.25 H	193	13.36	22.49
3	632.61	42.78 QP	46.00	-3.22	1.75 H	79	19.75	23.03
4	671.48	37.06 QP	46.00	-8.94	1.25 H	343	13.39	23.67
5	743.41	37.23 QP	46.00	-8.77	1.25 H	100	11.97	25.26
6	772.57	33.28 QP	46.00	-12.72	1.25 H	337	7.72	25.56
7	792.00	35.22 QP	46.00	-10.78	1.75 H	79	9.56	25.66
8	904.75	35.92 QP	46.00	-10.08	1.75 H	64	8.59	27.33

ANTENNA POLARITY & TEST DISTANCE: VERTICAL AT 3 M								
No.	Freq. (MHz)	Emission Level (dBuV/m)	Limit (dBuV/m)	Margin (dB)	Antenna Height (m)	Table Angle (Degree)	Raw Value (dBuV)	Correction Factor (dB/m)
1	53.33	21.64 QP	40.00	-18.36	1.25 V	136	7.04	14.60
2	311.86	28.39 QP	46.00	-17.61	1.50 V	256	12.94	15.46
3	469.32	36.68 QP	46.00	-9.32	1.00 V	37	16.99	19.69
4	570.40	34.53 QP	46.00	-11.47	1.25 V	70	12.94	21.59
5	619.00	33.76 QP	46.00	-12.24	1.75 V	97	11.02	22.74
6	675.37	35.33 QP	46.00	-10.67	1.00 V	292	11.61	23.72
7	737.58	35.94 QP	46.00	-10.06	1.75 V	196	10.84	25.10
8	805.61	32.59 QP	46.00	-13.41	1.50 V	211	6.78	25.81
9	879.48	32.96 QP	46.00	-13.04	1.00 V	301	5.94	27.03
10	914.47	34.74 QP	46.00	-11.26	1.50 V	142	7.29	27.46
11	947.52	34.08 QP	46.00	-11.92	1.00 V	244	6.20	27.88
12	982.51	36.37 QP	54.00	-17.63	1.00 V	145	8.27	28.09

- REMARKS:**
1. Emission level(dBuV/m)=Raw Value(dBuV) + Correction Factor(dB/m)
 2. Correction Factor(dB/m) = Antenna Factor (dB/m) + Cable Factor (dB)
 3. The other emission levels were very low against the limit.
 4. Margin value = Emission level – Limit value.

DRAFT 802.11n (20MHz) OFDM MODULATION:

EUT TEST CONDITION		MEASUREMENT DETAIL	
CHANNEL	Channel 1	FREQUENCY RANGE	Below 1000MHz
MODULATION TYPE	BPSK for draft 802.11n (20MHz)	INPUT POWER (SYSTEM)	120Vac, 60 Hz
TRANSFER RATE	6.5Mbps	DETECTOR FUNCTION	Quasi-Peak
ENVIRONMENTAL CONDITIONS	25deg. C, 68%RH, 991hPa	TESTED BY	Morgan Chen

ANTENNA POLARITY & TEST DISTANCE: HORIZONTAL AT 3 M								
No.	Freq. (MHz)	Emission Level (dBuV/m)	Limit (dBuV/m)	Margin (dB)	Antenna Height (m)	Table Angle (Degree)	Raw Value (dBuV)	Correction Factor (dB/m)
1	315.75	33.82 QP	46.00	-12.18	1.00 H	199	18.26	15.56
2	471.26	35.62 QP	46.00	-10.38	1.00 H	295	15.90	19.72
3	506.25	31.02 QP	46.00	-14.98	1.25 H	64	10.74	20.28
4	607.33	36.17 QP	46.00	-9.83	1.00 H	25	13.68	22.49
5	632.61	37.50 QP	46.00	-8.50	1.25 H	28	14.47	23.03
6	671.48	37.48 QP	46.00	-8.52	1.25 H	64	13.80	23.67
7	692.87	31.85 QP	46.00	-14.15	1.00 H	70	7.90	23.95
8	743.41	37.53 QP	46.00	-8.47	1.00 H	199	12.26	25.26
9	772.57	32.88 QP	46.00	-13.12	1.00 H	121	7.31	25.56
10	811.44	31.49 QP	46.00	-14.51	1.00 H	61	5.56	25.92

ANTENNA POLARITY & TEST DISTANCE: VERTICAL AT 3 M								
No.	Freq. (MHz)	Emission Level (dBuV/m)	Limit (dBuV/m)	Margin (dB)	Antenna Height (m)	Table Angle (Degree)	Raw Value (dBuV)	Correction Factor (dB/m)
1	475.15	41.69 QP	46.00	-4.31	1.00 V	358	21.91	19.78
2	580.12	34.12 QP	46.00	-11.88	1.25 V	112	12.29	21.83
3	622.89	35.19 QP	46.00	-10.81	1.00 V	106	12.37	22.82
4	636.49	39.13 QP	46.00	-6.87	1.00 V	58	16.01	23.11
5	675.37	33.92 QP	46.00	-12.08	1.25 V	109	10.19	23.72
6	743.41	36.00 QP	46.00	-10.00	1.25 V	112	10.73	25.26
7	772.57	32.21 QP	46.00	-13.79	1.25 V	112	6.65	25.56
8	805.61	32.17 QP	46.00	-13.83	1.25 V	112	6.36	25.81
9	840.60	31.38 QP	46.00	-14.62	1.00 V	70	4.88	26.50
10	873.65	32.85 QP	46.00	-13.15	1.00 V	304	5.89	26.96
11	914.47	33.67 QP	46.00	-12.33	1.25 V	121	6.22	27.46
12	947.52	33.68 QP	46.00	-12.32	1.00 V	79	5.80	27.88

- REMARKS:**
1. Emission level(dBuV/m)=Raw Value(dBuV) + Correction Factor(dB/m)
 2. Correction Factor(dB/m) = Antenna Factor (dB/m) + Cable Factor (dB)
 3. The other emission levels were very low against the limit.
 4. Margin value = Emission level – Limit value.

DRAFT 802.11n (40MHz) OFDM MODULATION:

EUT TEST CONDITION		MEASUREMENT DETAIL	
CHANNEL	Channel 1	FREQUENCY RANGE	Below 1000MHz
MODULATION TYPE	BPSK for draft 802.11n (40MHz)	INPUT POWER (SYSTEM)	120Vac, 60 Hz
TRANSFER RATE	13.5Mbps	DETECTOR FUNCTION	Quasi-Peak
ENVIRONMENTAL CONDITIONS	25deg. C, 68%RH, 991hPa	TESTED BY	Morgan Chen

ANTENNA POLARITY & TEST DISTANCE: HORIZONTAL AT 3 M								
No.	Freq. (MHz)	Emission Level (dBuV/m)	Limit (dBuV/m)	Margin (dB)	Antenna Height (m)	Table Angle (Degree)	Raw Value (dBuV)	Correction Factor (dB/m)
1	315.75	33.49 QP	46.00	-12.51	1.25 H	349	17.93	15.56
2	471.26	35.34 QP	46.00	-10.66	1.25 H	70	15.62	19.72
3	580.12	35.25 QP	46.00	-10.75	1.25 H	349	13.42	21.83
4	607.33	36.04 QP	46.00	-9.96	1.25 H	295	13.55	22.49
5	634.55	39.15 QP	46.00	-6.85	1.50 H	25	16.08	23.07
6	671.48	37.33 QP	46.00	-8.67	1.25 H	232	13.66	23.67
7	704.53	32.62 QP	46.00	-13.38	1.25 H	232	8.46	24.17
8	743.41	38.10 QP	46.00	-7.90	1.25 H	349	12.84	25.26
9	772.57	33.63 QP	46.00	-12.37	1.25 H	172	8.07	25.56
10	811.44	31.26 QP	46.00	-14.74	1.25 H	190	5.34	25.92
11	939.74	31.22 QP	46.00	-14.78	1.00 H	172	3.45	27.78

ANTENNA POLARITY & TEST DISTANCE: VERTICAL AT 3 M								
No.	Freq. (MHz)	Emission Level (dBuV/m)	Limit (dBuV/m)	Margin (dB)	Antenna Height (m)	Table Angle (Degree)	Raw Value (dBuV)	Correction Factor (dB/m)
1	471.26	32.07 QP	46.00	-13.93	1.00 V	118	12.34	19.72
2	560.68	32.87 QP	46.00	-13.13	1.00 V	79	11.52	21.35
3	619.00	37.28 QP	46.00	-8.72	1.25 V	229	14.54	22.74
4	636.49	35.82 QP	46.00	-10.18	1.00 V	118	12.71	23.11
5	671.48	33.80 QP	46.00	-12.20	1.25 V	136	10.12	23.67
6	739.52	35.69 QP	46.00	-10.31	1.25 V	109	10.53	25.15
7	772.57	31.90 QP	46.00	-14.10	1.25 V	109	6.33	25.56
8	795.89	32.26 QP	46.00	-13.74	1.00 V	118	6.59	25.68
9	873.65	32.42 QP	46.00	-13.58	1.25 V	229	5.47	26.96
10	914.47	33.95 QP	46.00	-12.05	1.00 V	112	6.50	27.46
11	947.52	33.61 QP	46.00	-12.39	1.25 V	103	5.73	27.88

- REMARKS:**
1. Emission level(dBuV/m)=Raw Value(dBuV) + Correction Factor(dB/m)
 2. Correction Factor(dB/m) = Antenna Factor (dB/m) + Cable Factor (dB)
 3. The other emission levels were very low against the limit.
 4. Margin value = Emission level – Limit value.

802.11b DSSS MODULATION:

EUT TEST CONDITION		MEASUREMENT DETAIL	
CHANNEL	Channel 1	FREQUENCY RANGE	1 ~ 25GHz
MODULATION TYPE	DBPSK	INPUT POWER (SYSTEM)	120Vac, 60 Hz
TRANSFER RATE	1Mbps	DETECTOR FUNCTION	Peak(PK) Average (AV)
ENVIRONMENTAL CONDITIONS	25deg. C, 68%RH, 991hPa	TESTED BY	Morgan Chen

ANTENNA POLARITY & TEST DISTANCE: HORIZONTAL AT 3 M								
NO.	FREQ. (MHz)	EMISSION LEVEL (dBuV/m)	LIMIT (dBuV/m)	MARGIN (dB)	ANTENNA HEIGHT (m)	TABLE ANGLE (Degree)	RAW VALUE (dBuV)	CORRECTION FACTOR (dB/m)
1	2388.00	53.33 PK	74.00	-20.67	1.03 H	38	21.85	31.48
2	2388.00	44.52 AV	54.00	-9.48	1.03 H	38	13.04	31.48
3	*2412.00	102.37 PK			1.13 H	42	70.78	31.59
4	*2412.00	98.02 AV			1.13 H	42	66.43	31.59
5	3216.00	47.33 PK	74.00	-26.67	1.02 H	310	13.84	33.49
6	3216.00	41.28 AV	54.00	-12.72	1.02 H	310	7.80	33.49
7	4824.00	49.39 PK	74.00	-24.61	1.02 H	11	11.86	37.53
8	4824.00	44.45 AV	54.00	-9.55	1.02 H	11	6.92	37.53

ANTENNA POLARITY & TEST DISTANCE: VERTICAL AT 3 M								
NO.	FREQ. (MHz)	EMISSION LEVEL (dBuV/m)	LIMIT (dBuV/m)	MARGIN (dB)	ANTENNA HEIGHT (m)	TABLE ANGLE (Degree)	RAW VALUE (dBuV)	CORRECTION FACTOR (dB/m)
1	2388.00	61.03 PK	74.00	-12.97	1.38 V	15	29.55	31.48
2	2388.00	52.61 AV	54.00	-1.39	1.38 V	15	21.13	31.48
3	*2412.00	110.95 PK			1.01 V	315	79.36	31.59
4	*2412.00	106.37 AV			1.01 V	315	74.78	31.59
5	3216.00	50.33 PK	74.00	-23.67	1.08 V	308	16.84	33.49
6	3216.00	44.28 AV	54.00	-9.72	1.08 V	308	10.79	33.49
7	4824.00	52.50 PK	74.00	-21.50	1.14 V	21	14.97	37.53
8	4824.00	47.43 AV	54.00	-6.57	1.14 V	21	9.90	37.53

- REMARKS:**
1. Emission level (dBuV/m) = Raw Value (dBuV) + Correction Factor (dB/m).
 2. Correction Factor (dB/m) = Antenna Factor (dB/m) + Cable Factor (dB).
 3. The other emission levels were very low against the limit.
 4. Margin value = Emission level – Limit value.
 5. The limit value is defined as per 15.247.
 6. “ * “: Fundamental frequency.



EUT TEST CONDITION		MEASUREMENT DETAIL	
CHANNEL	Channel 6	FREQUENCY RANGE	1 ~ 25GHz
MODULATION TYPE	DBPSK	INPUT POWER (SYSTEM)	120Vac, 60 Hz
TRANSFER RATE	1Mbps	DETECTOR FUNCTION	Peak(PK) Average (AV)
ENVIRONMENTAL CONDITIONS	25deg. C, 68%RH, 991hPa	TESTED BY	Morgan Chen

ANTENNA POLARITY & TEST DISTANCE: HORIZONTAL AT 3 M								
NO.	FREQ. (MHz)	EMISSION LEVEL (dBuV/m)	LIMIT (dBuV/m)	MARGIN (dB)	ANTENNA HEIGHT (m)	TABLE ANGLE (Degree)	RAW VALUE (dBuV)	CORRECTION FACTOR (dB/m)
1	*2437.00	104.55 PK			1.09 H	37	72.85	31.70
2	*2437.00	100.10 AV			1.09 H	37	68.40	31.70
3	3249.00	47.51 PK	74.00	-26.49	1.03 H	312	13.92	33.59
4	3249.00	41.42 AV	54.00	-12.58	1.03 H	312	7.83	33.59
5	4874.00	62.12 PK	74.00	-11.88	1.02 H	301	24.47	37.65
6	4874.00	47.85 AV	54.00	-6.15	1.02 H	301	10.20	37.65
7	7311.00	65.45 PK	74.00	-8.55	1.02 H	8	21.36	44.09
8	7311.00	49.71 AV	54.00	-4.29	1.02 H	8	5.62	44.09

ANTENNA POLARITY & TEST DISTANCE: VERTICAL AT 3 M								
NO.	FREQ. (MHz)	EMISSION LEVEL (dBuV/m)	LIMIT (dBuV/m)	MARGIN (dB)	ANTENNA HEIGHT (m)	TABLE ANGLE (Degree)	RAW VALUE (dBuV)	CORRECTION FACTOR (dB/m)
1	*2437.00	113.62 PK			1.19 V	31	81.92	31.70
2	*2437.00	108.71 AV			1.19 V	31	77.01	31.70
3	3249.00	51.53 PK	74.00	-22.47	1.04 V	15	17.94	33.59
4	3249.00	46.89 AV	54.00	-7.11	1.04 V	15	13.30	33.59
5	4874.00	65.98 PK	74.00	-8.02	1.21 V	35	28.33	37.65
6	4874.00	50.35 AV	54.00	-3.65	1.21 V	35	12.70	37.65
7	7311.00	68.05 PK	74.00	-5.95	1.13 V	54	23.96	44.09
8	7311.00	52.55 AV	54.00	-1.45	1.13 V	54	8.46	44.09

- REMARKS:**
1. Emission level (dBuV/m) = Raw Value (dBuV) + Correction Factor (dB/m).
 2. Correction Factor (dB/m) = Antenna Factor (dB/m) + Cable Factor (dB).
 3. The other emission levels were very low against the limit.
 4. Margin value = Emission level – Limit value.
 5. The limit value is defined as per 15.247.
 6. “ * “: Fundamental frequency.



EUT TEST CONDITION		MEASUREMENT DETAIL	
CHANNEL	Channel 11	FREQUENCY RANGE	1 ~ 25GHz
MODULATION TYPE	DBPSK	INPUT POWER (SYSTEM)	120Vac, 60 Hz
TRANSFER RATE	1Mbps	DETECTOR FUNCTION	Peak(PK) Average (AV)
ENVIRONMENTAL CONDITIONS	25deg. C, 68%RH, 991hPa	TESTED BY	Morgan Chen

ANTENNA POLARITY & TEST DISTANCE: HORIZONTAL AT 3 M								
NO.	FREQ. (MHz)	EMISSION LEVEL (dBuV/m)	LIMIT (dBuV/m)	MARGIN (dB)	ANTENNA HEIGHT (m)	TABLE ANGLE (Degree)	RAW VALUE (dBuV)	CORRECTION FACTOR (dB/m)
1	*2462.00	102.58 PK			1.18 H	39	70.76	31.82
2	*2462.00	98.16 AV			1.18 H	39	66.35	31.82
3	2486.00	53.18 PK	74.00	-20.82	1.01 H	29	21.25	31.93
4	2486.00	43.21 AV	54.00	-10.79	1.01 H	29	11.28	31.93
5	3282.00	47.58 PK	74.00	-26.42	1.03 H	12	13.89	33.69
6	3282.00	41.36 AV	54.00	-12.64	1.03 H	12	7.67	33.69
7	4924.00	49.52 PK	74.00	-24.48	1.10 H	358	11.76	37.76
8	4924.00	44.50 AV	54.00	-9.50	1.10 H	358	6.74	37.76

ANTENNA POLARITY & TEST DISTANCE: VERTICAL AT 3 M								
NO.	FREQ. (MHz)	EMISSION LEVEL (dBuV/m)	LIMIT (dBuV/m)	MARGIN (dB)	ANTENNA HEIGHT (m)	TABLE ANGLE (Degree)	RAW VALUE (dBuV)	CORRECTION FACTOR (dB/m)
1	*2462.00	110.98 PK			1.03 V	301	79.16	31.82
2	*2462.00	106.39 AV			1.03 V	301	74.57	31.82
3	2486.00	60.85 PK	74.00	-13.15	1.16 V	6	28.92	31.93
4	2486.00	52.09 AV	54.00	-1.91	1.16 V	6	20.16	31.93
5	3282.00	51.02 PK	74.00	-22.98	1.03 V	325	17.33	33.69
6	3282.00	45.11 AV	54.00	-8.89	1.03 V	325	11.42	33.69
7	4924.00	52.38 PK	74.00	-21.62	1.10 V	30	14.62	37.76
8	4924.00	47.32 AV	54.00	-6.68	1.10 V	30	9.56	37.76

- REMARKS:**
1. Emission level (dBuV/m) = Raw Value (dBuV) + Correction Factor (dB/m).
 2. Correction Factor (dB/m) = Antenna Factor (dB/m) + Cable Factor (dB).
 3. The other emission levels were very low against the limit.
 4. Margin value = Emission level – Limit value.
 5. The limit value is defined as per 15.247.
 6. “ * “: Fundamental frequency.

802.11g OFDM MODULATION:

EUT TEST CONDITION		MEASUREMENT DETAIL	
CHANNEL	Channel 1	FREQUENCY RANGE	1 ~ 25GHz
MODULATION TYPE	BPSK	INPUT POWER (SYSTEM)	120Vac, 60 Hz
TRANSFER RATE	6Mbps	DETECTOR FUNCTION	Peak(PK) Average (AV)
ENVIRONMENTAL CONDITIONS	25deg. C, 68%RH, 991hPa	TESTED BY	Morgan Chen

ANTENNA POLARITY & TEST DISTANCE: HORIZONTAL AT 3 M								
NO.	FREQ. (MHz)	EMISSION LEVEL (dBuV/m)	LIMIT (dBuV/m)	MARGIN (dB)	ANTENNA HEIGHT (m)	TABLE ANGLE (Degree)	RAW VALUE (dBuV)	CORRECTION FACTOR (dB/m)
1	2390.00	53.88 PK	74.00	-20.12	1.05 H	313	22.40	31.49
2	2390.00	43.72 AV	54.00	-10.28	1.05 H	313	12.23	31.49
3	*2412.00	101.75 PK			1.03 H	311	70.16	31.59
4	*2412.00	88.83 AV			1.03 H	311	57.24	31.59
5	3216.00	47.22 PK	74.00	-26.78	1.08 H	305	13.73	33.49
6	3216.00	42.41 AV	54.00	-11.59	1.08 H	305	8.92	33.49
7	4824.00	48.86 PK	74.00	-25.14	1.05 H	259	11.33	37.53
8	4824.00	41.76 AV	54.00	-12.24	1.05 H	259	4.23	37.53

ANTENNA POLARITY & TEST DISTANCE: VERTICAL AT 3 M								
NO.	FREQ. (MHz)	EMISSION LEVEL (dBuV/m)	LIMIT (dBuV/m)	MARGIN (dB)	ANTENNA HEIGHT (m)	TABLE ANGLE (Degree)	RAW VALUE (dBuV)	CORRECTION FACTOR (dB/m)
1	2390.00	62.89 PK	74.00	-11.11	1.05 V	308	31.40	31.49
2	2390.00	52.59 AV	54.00	-1.41	1.05 V	308	21.10	31.49
3	*2412.00	110.56 PK			1.03 V	302	78.97	31.59
4	*2412.00	97.79 AV			1.03 V	302	66.20	31.59
5	3216.00	50.68 PK	74.00	-23.32	1.06 V	302	17.19	33.49
6	3216.00	44.68 AV	54.00	-9.32	1.06 V	302	11.19	33.49
7	4824.00	51.98 PK	74.00	-22.02	1.03 V	325	14.45	37.53
8	4824.00	44.83 AV	54.00	-9.17	1.03 V	325	7.30	37.53

- REMARKS:**
1. Emission level (dBuV/m) = Raw Value (dBuV) + Correction Factor (dB/m).
 2. Correction Factor (dB/m) = Antenna Factor (dB/m) + Cable Factor (dB).
 3. The other emission levels were very low against the limit.
 4. Margin value = Emission level – Limit value.
 5. The limit value is defined as per 15.247.
 6. “ * “: Fundamental frequency.



EUT TEST CONDITION		MEASUREMENT DETAIL	
CHANNEL	Channel 6	FREQUENCY RANGE	1 ~ 25GHz
MODULATION TYPE	BPSK	INPUT POWER (SYSTEM)	120Vac, 60 Hz
TRANSFER RATE	6Mbps	DETECTOR FUNCTION	Peak(PK) Average (AV)
ENVIRONMENTAL CONDITIONS	25deg. C, 68%RH, 991hPa	TESTED BY	Morgan Chen

ANTENNA POLARITY & TEST DISTANCE: HORIZONTAL AT 3 M								
NO.	FREQ. (MHz)	EMISSION LEVEL (dBuV/m)	LIMIT (dBuV/m)	MARGIN (dB)	ANTENNA HEIGHT (m)	TABLE ANGLE (Degree)	RAW VALUE (dBuV)	CORRECTION FACTOR (dB/m)
1	*2437.00	104.31 PK			1.05 H	315	72.61	31.70
2	*2437.00	91.42 AV			1.05 H	315	59.72	31.70
3	3248.00	47.55 PK	74.00	-26.45	1.01 H	302	13.96	33.59
4	3248.00	42.61 AV	54.00	-11.39	1.01 H	302	9.02	33.59
5	4874.00	51.33 PK	74.00	-22.67	1.08 H	305	13.68	37.65
6	4874.00	44.35 AV	54.00	-9.65	1.08 H	305	6.70	37.65

ANTENNA POLARITY & TEST DISTANCE: VERTICAL AT 3 M								
NO.	FREQ. (MHz)	EMISSION LEVEL (dBuV/m)	LIMIT (dBuV/m)	MARGIN (dB)	ANTENNA HEIGHT (m)	TABLE ANGLE (Degree)	RAW VALUE (dBuV)	CORRECTION FACTOR (dB/m)
1	2390.00	57.02 PK	74.00	-16.98	1.25 V	68	25.53	31.49
2	2390.00	46.71 AV	54.00	-7.29	1.25 V	68	15.22	31.49
3	*2437.00	112.82 PK			1.23 V	314	81.12	31.70
4	*2437.00	100.41 AV			1.23 V	314	68.71	31.70
5	2483.50	57.90 PK	74.00	-16.10	1.25 V	68	25.99	31.91
6	2483.50	47.59 AV	54.00	-6.41	1.25 V	68	15.68	31.91
7	3429.00	49.68 PK	74.00	-24.32	1.27 V	338	15.56	34.12
8	3429.00	45.36 AV	54.00	-8.64	1.27 V	338	11.24	34.12
9	4874.00	55.65 PK	74.00	-18.35	1.08 V	352	18.00	37.65
10	4874.00	48.78 AV	54.00	-5.22	1.08 V	352	11.13	37.65

- REMARKS:**
1. Emission level (dBuV/m) = Raw Value (dBuV) + Correction Factor (dB/m).
 2. Correction Factor (dB/m) = Antenna Factor (dB/m) + Cable Factor (dB).
 3. The other emission levels were very low against the limit.
 4. Margin value = Emission level – Limit value.
 5. The limit value is defined as per 15.247.
 6. “ * “: Fundamental frequency.

EUT TEST CONDITION		MEASUREMENT DETAIL	
CHANNEL	Channel 11	FREQUENCY RANGE	1 ~ 25GHz
MODULATION TYPE	BPSK	INPUT POWER (SYSTEM)	120Vac, 60 Hz
TRANSFER RATE	6Mbps	DETECTOR FUNCTION	Peak(PK) Average (AV)
ENVIRONMENTAL CONDITIONS	25deg. C, 68%RH, 991hPa	TESTED BY	Morgan Chen

ANTENNA POLARITY & TEST DISTANCE: HORIZONTAL AT 3 M								
NO.	FREQ. (MHz)	EMISSION LEVEL (dBuV/m)	LIMIT (dBuV/m)	MARGIN (dB)	ANTENNA HEIGHT (m)	TABLE ANGLE (Degree)	RAW VALUE (dBuV)	CORRECTION FACTOR (dB/m)
1	*2462.00	101.22 PK			1.03 H	309	69.40	31.82
2	*2462.00	88.32 AV			1.03 H	309	56.50	31.82
3	2483.50	53.55 PK	74.00	-20.45	1.06 H	320	21.64	31.91
4	2483.50	43.28 AV	54.00	-10.72	1.06 H	320	11.37	31.91
5	3282.00	47.12 PK	74.00	-26.88	1.03 H	330	13.43	33.69
6	3282.00	42.52 AV	54.00	-11.48	1.03 H	330	8.83	33.69
7	4924.00	48.33 PK	74.00	-25.67	1.03 H	230	10.57	37.76
8	4924.00	41.25 AV	54.00	-12.75	1.03 H	230	3.49	37.76

ANTENNA POLARITY & TEST DISTANCE: VERTICAL AT 3 M								
NO.	FREQ. (MHz)	EMISSION LEVEL (dBuV/m)	LIMIT (dBuV/m)	MARGIN (dB)	ANTENNA HEIGHT (m)	TABLE ANGLE (Degree)	RAW VALUE (dBuV)	CORRECTION FACTOR (dB/m)
1	*2462.00	110.01 PK			1.19 V	315	78.19	31.82
2	*2462.00	97.28 AV			1.19 V	315	65.46	31.82
3	2483.50	62.33 PK	74.00	-11.67	1.08 V	308	30.42	31.91
4	2483.50	52.16 AV	54.00	-1.84	1.08 V	308	20.25	31.91
5	3282.00	50.35 PK	74.00	-23.65	1.08 V	26	16.66	33.69
6	3282.00	44.52 AV	54.00	-9.48	1.08 V	26	10.83	33.69
7	4924.00	51.33 PK	74.00	-22.67	1.06 V	302	13.57	37.76
8	4924.00	44.12 AV	54.00	-9.88	1.06 V	302	6.36	37.76

- REMARKS:**
1. Emission level (dBuV/m) = Raw Value (dBuV) + Correction Factor (dB/m).
 2. Correction Factor (dB/m) = Antenna Factor (dB/m) + Cable Factor (dB).
 3. The other emission levels were very low against the limit.
 4. Margin value = Emission level – Limit value.
 5. The limit value is defined as per 15.247.
 6. “ * “: Fundamental frequency.



DRAFT 802.11n (20MHz) OFDM modulation: DUAL TX

EUT TEST CONDITION		MEASUREMENT DETAIL	
CHANNEL	Channel 1	FREQUENCY RANGE	1 ~ 25GHz
MODULATION TYPE	BPSK	INPUT POWER (SYSTEM)	120Vac, 60 Hz
TRANSFER RATE	6.5Mbps	DETECTOR FUNCTION	Peak(PK) Average (AV)
ENVIRONMENTAL CONDITIONS	25deg. C, 68%RH, 991hPa	TESTED BY	Morgan Chen

ANTENNA POLARITY & TEST DISTANCE: HORIZONTAL AT 3 M								
NO.	FREQ. (MHz)	EMISSION LEVEL (dBuV/m)	LIMIT (dBuV/m)	MARGIN (dB)	ANTENNA HEIGHT (m)	TABLE ANGLE (Degree)	RAW VALUE (dBuV)	CORRECTION FACTOR (dB/m)
1	2390.00	63.55 PK	74.00	-10.45	1.06 H	321	32.06	31.49
2	2390.00	43.78 AV	54.00	-10.22	1.06 H	321	12.29	31.49
3	*2412.00	103.54 PK			1.05 H	318	71.95	31.59
4	*2412.00	92.42 AV			1.05 H	318	60.83	31.59
5	3216.00	47.88 PK	74.00	-26.12	1.03 H	321	14.39	33.49
6	3216.00	42.64 AV	54.00	-11.36	1.03 H	321	9.15	33.49
7	4824.00	49.33 PK	74.00	-24.67	1.05 H	302	11.80	37.53
8	4824.00	42.42 AV	54.00	-11.58	1.05 H	302	4.89	37.53

ANTENNA POLARITY & TEST DISTANCE: VERTICAL AT 3 M								
NO.	FREQ. (MHz)	EMISSION LEVEL (dBuV/m)	LIMIT (dBuV/m)	MARGIN (dB)	ANTENNA HEIGHT (m)	TABLE ANGLE (Degree)	RAW VALUE (dBuV)	CORRECTION FACTOR (dB/m)
1	2390.00	72.67 PK	74.00	-1.33	1.16 V	32	41.18	31.49
2	2390.00	52.18 AV	54.00	-1.82	1.16 V	32	20.69	31.49
3	*2412.00	112.28 PK			1.18 V	31	80.69	31.59
4	*2412.00	101.59 AV			1.18 V	31	70.00	31.59
5	3216.00	50.68 PK	74.00	-23.32	1.03 V	32	17.19	33.49
6	3216.00	45.23 AV	54.00	-8.77	1.03 V	32	11.74	33.49
7	4824.00	52.15 PK	74.00	-21.85	1.08 V	315	14.62	37.53
8	4824.00	45.33 AV	54.00	-8.67	1.08 V	315	7.80	37.53

- REMARKS:**
1. Emission level (dBuV/m) = Raw Value (dBuV) + Correction Factor (dB/m).
 2. Correction Factor (dB/m) = Antenna Factor (dB/m) + Cable Factor (dB).
 3. The other emission levels were very low against the limit.
 4. Margin value = Emission level – Limit value.
 5. The limit value is defined as per 15.247.
 6. “ * “: Fundamental frequency.

EUT TEST CONDITION		MEASUREMENT DETAIL	
CHANNEL	Channel 6	FREQUENCY RANGE	1 ~ 25GHz
MODULATION TYPE	BPSK	INPUT POWER (SYSTEM)	120Vac, 60 Hz
TRANSFER RATE	6.5Mbps	DETECTOR FUNCTION	Peak(PK) Average (AV)
ENVIRONMENTAL CONDITIONS	25deg. C, 68%RH, 991hPa	TESTED BY	Morgan Chen

ANTENNA POLARITY & TEST DISTANCE: HORIZONTAL AT 3 M								
NO.	FREQ. (MHz)	EMISSION LEVEL (dBuV/m)	LIMIT (dBuV/m)	MARGIN (dB)	ANTENNA HEIGHT (m)	TABLE ANGLE (Degree)	RAW VALUE (dBuV)	CORRECTION FACTOR (dB/m)
1	2390.00	61.33 PK	74.00	-12.67	1.05 H	305	29.84	31.49
2	2390.00	41.55 AV	54.00	-12.45	1.05 H	305	10.06	31.49
3	*2437.00	106.33 PK			1.03 H	302	74.63	31.70
4	*2437.00	95.28 AV			1.03 H	302	63.58	31.70
5	2483.50	62.53 PK	74.00	-11.47	1.08 H	315	30.62	31.91
6	2483.50	42.59 AV	54.00	-11.41	1.08 H	315	10.68	31.91
7	3249.00	47.98 PK	74.00	-26.02	1.03 H	305	14.39	33.59
8	3249.00	42.75 AV	54.00	-11.25	1.03 H	305	9.16	33.59
9	4874.00	52.33 PK	74.00	-21.67	1.03 H	313	14.68	37.65
10	4874.00	45.31 AV	54.00	-8.69	1.03 H	313	7.66	37.65

ANTENNA POLARITY & TEST DISTANCE: VERTICAL AT 3 M								
NO.	FREQ. (MHz)	EMISSION LEVEL (dBuV/m)	LIMIT (dBuV/m)	MARGIN (dB)	ANTENNA HEIGHT (m)	TABLE ANGLE (Degree)	RAW VALUE (dBuV)	CORRECTION FACTOR (dB/m)
1	2390.00	62.12 PK	74.00	-11.88	1.00 V	43	30.63	31.49
2	2390.00	51.23 AV	54.00	-2.77	1.00 V	43	19.74	31.49
3	*2437.00	115.70 PK			1.00 V	49	84.00	31.70
4	*2437.00	102.41 AV			1.00 V	49	70.71	31.70
5	2483.50	62.80 PK	74.00	-11.20	1.00 V	53	30.89	31.91
6	2483.50	51.71 AV	54.00	-2.29	1.00 V	53	19.80	31.91
7	3429.00	50.22 PK	74.00	-23.78	1.23 V	321	16.10	34.12
8	3429.00	45.65 AV	54.00	-8.35	1.23 V	321	11.53	34.12
9	4874.00	56.88 PK	74.00	-17.12	1.02 V	337	19.23	37.65
10	4874.00	49.82 AV	54.00	-4.18	1.02 V	337	12.17	37.65

- REMARKS:**
1. Emission level (dBuV/m) = Raw Value (dBuV) + Correction Factor (dB/m).
 2. Correction Factor (dB/m) = Antenna Factor (dB/m) + Cable Factor (dB).
 3. The other emission levels were very low against the limit.
 4. Margin value = Emission level – Limit value.
 5. The limit value is defined as per 15.247.
 6. “ * “: Fundamental frequency.

EUT TEST CONDITION		MEASUREMENT DETAIL	
CHANNEL	Channel 11	FREQUENCY RANGE	1 ~ 25GHz
MODULATION TYPE	BPSK	INPUT POWER (SYSTEM)	120Vac, 60 Hz
TRANSFER RATE	6.5Mbps	DETECTOR FUNCTION	Peak(PK) Average (AV)
ENVIRONMENTAL CONDITIONS	25deg. C, 68%RH, 991hPa	TESTED BY	Morgan Chen

ANTENNA POLARITY & TEST DISTANCE: HORIZONTAL AT 3 M								
NO.	FREQ. (MHz)	EMISSION LEVEL (dBuV/m)	LIMIT (dBuV/m)	MARGIN (dB)	ANTENNA HEIGHT (m)	TABLE ANGLE (Degree)	RAW VALUE (dBuV)	CORRECTION FACTOR (dB/m)
1	*2462.00	103.02 PK			1.08 H	305	71.20	31.82
2	*2462.00	91.98 AV			1.08 H	305	60.16	31.82
3	2483.50	63.18 PK	74.00	-10.82	1.03 H	311	31.27	31.91
4	2483.50	43.30 AV	54.00	-10.70	1.03 H	311	11.39	31.91
5	3282.00	47.52 PK	74.00	-26.48	1.08 H	305	13.83	33.69
6	3282.00	42.35 AV	54.00	-11.65	1.08 H	305	8.66	33.69
7	4924.00	48.85 PK	74.00	-25.15	1.03 H	321	11.09	37.76
8	4924.00	41.76 AV	54.00	-12.24	1.03 H	321	4.00	37.76

ANTENNA POLARITY & TEST DISTANCE: VERTICAL AT 3 M								
NO.	FREQ. (MHz)	EMISSION LEVEL (dBuV/m)	LIMIT (dBuV/m)	MARGIN (dB)	ANTENNA HEIGHT (m)	TABLE ANGLE (Degree)	RAW VALUE (dBuV)	CORRECTION FACTOR (dB/m)
1	*2462.00	111.73 PK			1.08 V	31	79.92	31.82
2	*2462.00	101.08 AV			1.08 V	31	69.26	31.82
3	2483.50	72.41 PK	74.00	-1.59	1.12 V	25	40.50	31.91
4	2483.50	52.02 AV	54.00	-1.98	1.12 V	25	20.11	31.91
5	3282.00	51.12 PK	74.00	-22.88	1.03 V	25	17.43	33.69
6	3282.00	46.02 AV	54.00	-7.98	1.03 V	25	12.33	33.69
7	4924.00	51.69 PK	74.00	-22.31	1.03 V	302	13.93	37.76
8	4924.00	44.75 AV	54.00	-9.25	1.03 V	302	6.99	37.76

- REMARKS:**
1. Emission level (dBuV/m) = Raw Value (dBuV) + Correction Factor (dB/m).
 2. Correction Factor (dB/m) = Antenna Factor (dB/m) + Cable Factor (dB).
 3. The other emission levels were very low against the limit.
 4. Margin value = Emission level – Limit value.
 5. The limit value is defined as per 15.247.
 6. “ * “: Fundamental frequency.



DRAFT 802.11n (40MHz) OFDM MODULATION: DUAL TX

EUT TEST CONDITION		MEASUREMENT DETAIL	
CHANNEL	Channel 1	FREQUENCY RANGE	1 ~ 25GHz
MODULATION TYPE	BPSK	INPUT POWER (SYSTEM)	120Vac, 60 Hz
TRANSFER RATE	13.5Mbps	DETECTOR FUNCTION	Peak(PK) Average (AV)
ENVIRONMENTAL CONDITIONS	25deg. C, 68%RH, 991hPa	TESTED BY	Morgan Chen

ANTENNA POLARITY & TEST DISTANCE: HORIZONTAL AT 3 M								
NO.	FREQ. (MHz)	EMISSION LEVEL (dBuV/m)	LIMIT (dBuV/m)	MARGIN (dB)	ANTENNA HEIGHT (m)	TABLE ANGLE (Degree)	RAW VALUE (dBuV)	CORRECTION FACTOR (dB/m)
1	2388.00	61.22 PK	74.00	-12.78	1.15 H	302	29.74	31.48
2	2388.00	43.52 AV	54.00	-10.48	1.15 H	302	12.04	31.48
3	*2422.00	101.23 PK			1.12 H	315	69.60	31.63
4	*2422.00	89.55 AV			1.12 H	315	57.92	31.63
5	3229.00	47.35 PK	74.00	-26.65	1.03 H	342	13.82	33.53
6	3229.00	42.22 AV	54.00	-11.78	1.03 H	342	8.69	33.53
7	4844.00	47.55 PK	74.00	-26.45	1.03 H	311	9.97	37.58
8	4844.00	40.35 AV	54.00	-13.65	1.03 H	311	2.77	37.58

ANTENNA POLARITY & TEST DISTANCE: VERTICAL AT 3 M								
NO.	FREQ. (MHz)	EMISSION LEVEL (dBuV/m)	LIMIT (dBuV/m)	MARGIN (dB)	ANTENNA HEIGHT (m)	TABLE ANGLE (Degree)	RAW VALUE (dBuV)	CORRECTION FACTOR (dB/m)
1	2388.00	69.41 PK	74.00	-4.59	1.00 V	315	37.93	31.48
2	2388.00	52.74 AV	54.00	-1.26	1.00 V	315	21.26	31.48
3	*2422.00	110.01 PK			1.00 V	20	78.38	31.63
4	*2422.00	97.82 AV			1.00 V	20	66.19	31.63
5	3229.00	50.55 PK	74.00	-23.45	1.03 V	325	17.02	33.53
6	3229.00	45.10 AV	54.00	-8.90	1.03 V	325	11.57	33.53
7	4844.00	50.33 PK	74.00	-23.67	1.05 V	329	12.75	37.58
8	4844.00	43.42 AV	54.00	-10.58	1.05 V	329	5.84	37.58

- REMARKS:**
1. Emission level (dBuV/m) = Raw Value (dBuV) + Correction Factor (dB/m).
 2. Correction Factor (dB/m) = Antenna Factor (dB/m) + Cable Factor (dB).
 3. The other emission levels were very low against the limit.
 4. Margin value = Emission level – Limit value.
 5. The limit value is defined as per 15.247.
 6. “ * “: Fundamental frequency.

EUT TEST CONDITION		MEASUREMENT DETAIL	
CHANNEL	Channel 4	FREQUENCY RANGE	1 ~ 25GHz
MODULATION TYPE	BPSK	INPUT POWER (SYSTEM)	120Vac, 60 Hz
TRANSFER RATE	13.5Mbps	DETECTOR FUNCTION	Peak(PK) Average (AV)
ENVIRONMENTAL CONDITIONS	25deg. C, 68%RH, 991hPa	TESTED BY	Morgan Chen

ANTENNA POLARITY & TEST DISTANCE: HORIZONTAL AT 3 M								
NO.	FREQ. (MHz)	EMISSION LEVEL (dBuV/m)	LIMIT (dBuV/m)	MARGIN (dB)	ANTENNA HEIGHT (m)	TABLE ANGLE (Degree)	RAW VALUE (dBuV)	CORRECTION FACTOR (dB/m)
1	2390.00	61.11 PK	74.00	-12.89	1.03 H	321	29.62	31.49
2	2390.00	43.42 AV	54.00	-10.58	1.03 H	321	11.93	31.49
3	*2437.00	104.18 PK			1.03 H	325	72.48	31.70
4	*2437.00	92.42 AV			1.03 H	325	60.72	31.70
5	2483.50	60.98 PK	74.00	-13.02	1.02 H	315	29.07	31.91
6	2483.50	42.35 AV	54.00	-11.65	1.02 H	315	10.44	31.91
7	3249.00	47.45 PK	74.00	-26.55	1.08 H	315	13.86	33.59
8	3249.00	42.15 AV	54.00	-11.85	1.08 H	315	8.56	33.59
9	4874.00	49.35 PK	74.00	-24.65	1.05 H	302	11.70	37.65
10	4874.00	41.25 AV	54.00	-12.75	1.05 H	302	3.60	37.65

ANTENNA POLARITY & TEST DISTANCE: VERTICAL AT 3 M								
NO.	FREQ. (MHz)	EMISSION LEVEL (dBuV/m)	LIMIT (dBuV/m)	MARGIN (dB)	ANTENNA HEIGHT (m)	TABLE ANGLE (Degree)	RAW VALUE (dBuV)	CORRECTION FACTOR (dB/m)
1	2390.00	70.77 PK	74.00	-3.23	1.00 V	313	39.28	31.49
2	2390.00	52.18 AV	54.00	-1.82	1.00 V	313	20.69	31.49
3	*2437.00	113.15 PK			1.00 V	313	81.45	31.70
4	*2437.00	100.79 AV			1.00 V	313	69.09	31.70
5	2485.00	72.14 PK	74.00	-1.86	1.00 V	307	40.22	31.92
6	2485.00	52.92 AV	54.00	-1.08	1.00 V	307	21.00	31.92
7	3249.00	49.59 PK	74.00	-24.41	1.04 V	335	16.00	33.59
8	3249.00	44.80 AV	54.00	-9.20	1.04 V	335	11.21	33.59
9	4874.00	52.48 PK	74.00	-21.52	1.03 V	348	14.83	37.65
10	4874.00	45.70 AV	54.00	-8.30	1.03 V	348	8.05	37.65

- REMARKS:**
1. Emission level (dBuV/m) = Raw Value (dBuV) + Correction Factor (dB/m).
 2. Correction Factor (dB/m) = Antenna Factor (dB/m) + Cable Factor (dB).
 3. The other emission levels were very low against the limit.
 4. Margin value = Emission level – Limit value.
 5. The limit value is defined as per 15.247.
 6. “ * “: Fundamental frequency.

EUT TEST CONDITION		MEASUREMENT DETAIL	
CHANNEL	Channel 7	FREQUENCY RANGE	1 ~ 25GHz
MODULATION TYPE	BPSK	INPUT POWER (SYSTEM)	120Vac, 60 Hz
TRANSFER RATE	13.5Mbps	DETECTOR FUNCTION	Peak(PK) Average (AV)
ENVIRONMENTAL CONDITIONS	25deg. C, 68%RH, 991hPa	TESTED BY	Morgan Chen

ANTENNA POLARITY & TEST DISTANCE: HORIZONTAL AT 3 M								
NO.	FREQ. (MHz)	EMISSION LEVEL (dBuV/m)	LIMIT (dBuV/m)	MARGIN (dB)	ANTENNA HEIGHT (m)	TABLE ANGLE (Degree)	RAW VALUE (dBuV)	CORRECTION FACTOR (dB/m)
1	*2452.00	100.35 PK			1.16 H	322	68.58	31.77
2	*2452.00	88.61 AV			1.16 H	322	56.84	31.77
3	2488.00	60.55 PK	74.00	-13.45	1.12 H	296	28.62	31.93
4	2488.00	42.81 AV	54.00	-11.19	1.12 H	296	10.88	31.93
5	3269.00	47.18 PK	74.00	-26.82	1.05 H	358	13.53	33.65
6	3269.00	42.05 AV	54.00	-11.95	1.05 H	358	8.40	33.65
7	4904.00	46.88 PK	74.00	-27.12	1.03 H	313	9.16	37.72
8	4904.00	39.56 AV	54.00	-14.44	1.03 H	313	1.84	37.72

ANTENNA POLARITY & TEST DISTANCE: VERTICAL AT 3 M								
NO.	FREQ. (MHz)	EMISSION LEVEL (dBuV/m)	LIMIT (dBuV/m)	MARGIN (dB)	ANTENNA HEIGHT (m)	TABLE ANGLE (Degree)	RAW VALUE (dBuV)	CORRECTION FACTOR (dB/m)
1	*2452.00	109.35 PK			1.01 V	15	77.58	31.77
2	*2452.00	97.72 AV			1.01 V	15	65.95	31.77
3	2488.00	69.12 PK	74.00	-4.88	1.02 V	332	37.19	31.93
4	2488.00	51.46 AV	54.00	-2.54	1.02 V	332	19.53	31.93
5	3269.00	51.02 PK	74.00	-22.98	1.05 V	315	17.37	33.65
6	3269.00	45.35 AV	54.00	-8.65	1.05 V	315	11.70	33.65
7	4904.00	50.01 PK	74.00	-23.99	1.02 V	325	12.29	37.72
8	4904.00	42.86 AV	54.00	-11.14	1.02 V	325	5.14	37.72

- REMARKS:**
1. Emission level (dBuV/m) = Raw Value (dBuV) + Correction Factor (dB/m).
 2. Correction Factor (dB/m) = Antenna Factor (dB/m) + Cable Factor (dB).
 3. The other emission levels were very low against the limit.
 4. Margin value = Emission level – Limit value.
 5. The limit value is defined as per 15.247.
 6. “ * “: Fundamental frequency.



4.3 6dB BANDWIDTH MEASUREMENT

4.3.1 LIMITS OF 6dB BANDWIDTH MEASUREMENT

The minimum of 6dB Bandwidth Measurement is 0.5 MHz.

4.3.2 TEST INSTRUMENTS

DESCRIPTION & MANUFACTURER	MODEL NO.	SERIAL NO.	CALIBRATED UNTIL
SPECTRUM ANALYZER	FSP 40	100040	Jun. 07, 2007

NOTE: The calibration interval of the above test instruments is 12 months and the calibrations are traceable to NML/ROC and NIST/USA.

4.3.3 TEST PROCEDURE

The transmitter output was connected to the spectrum analyzer through an attenuator. The bandwidth of the fundamental frequency was measured by spectrum analyzer with 100kHz RBW and 100kHz VBW. The 6dB bandwidth is defined as the total spectrum the power of which is higher than peak power minus 6dB.

4.3.4 DEVIATION FROM TEST STANDARD

No deviation

4.3.5 TEST SETUP

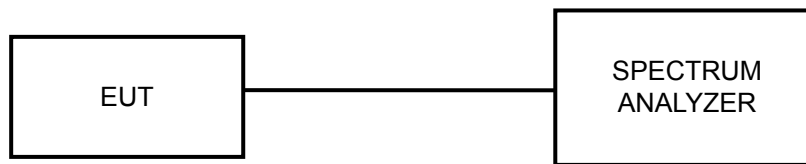

4.3.6 EUT OPERATING CONDITIONS

The software provided by client to enable the EUT under transmission condition continuously at lowest, middle and highest channel frequencies individually.

4.3.7 TEST RESULTS

802.11b DSSS MODULATION:

MODULATION TYPE	DBPSK	TRANSFER RATE	1Mbps
INPUT POWER (SYSTEM)	120Vac, 60 Hz	ENVIRONMENTAL CONDITIONS	25deg.C, 63%RH, 991hPa
TESTED BY	Match Tsui		

CHANNEL	CHANNEL FREQUENCY (MHz)	6dB BANDWIDTH (MHz)	MINIMUM LIMIT (MHz)	PASS / FAIL
1	2412	10.12	0.5	PASS
6	2437	10.16	0.5	PASS
11	2462	10.16	0.5	PASS

CH 1

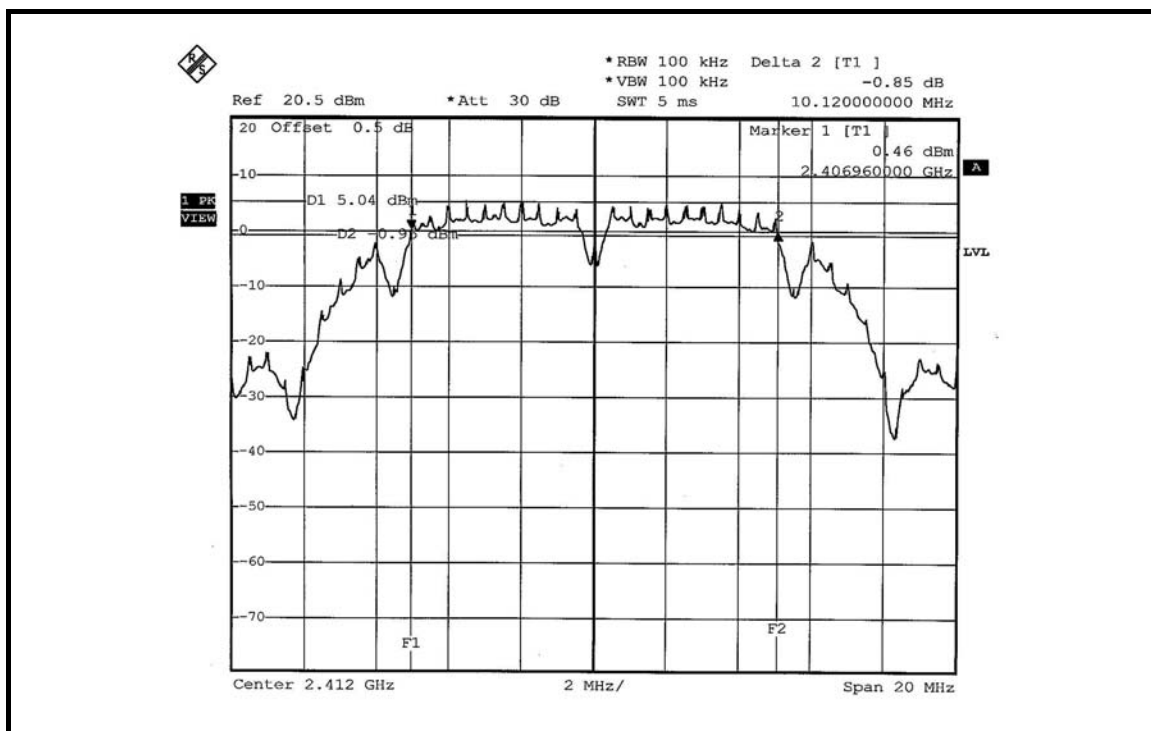

CH 6

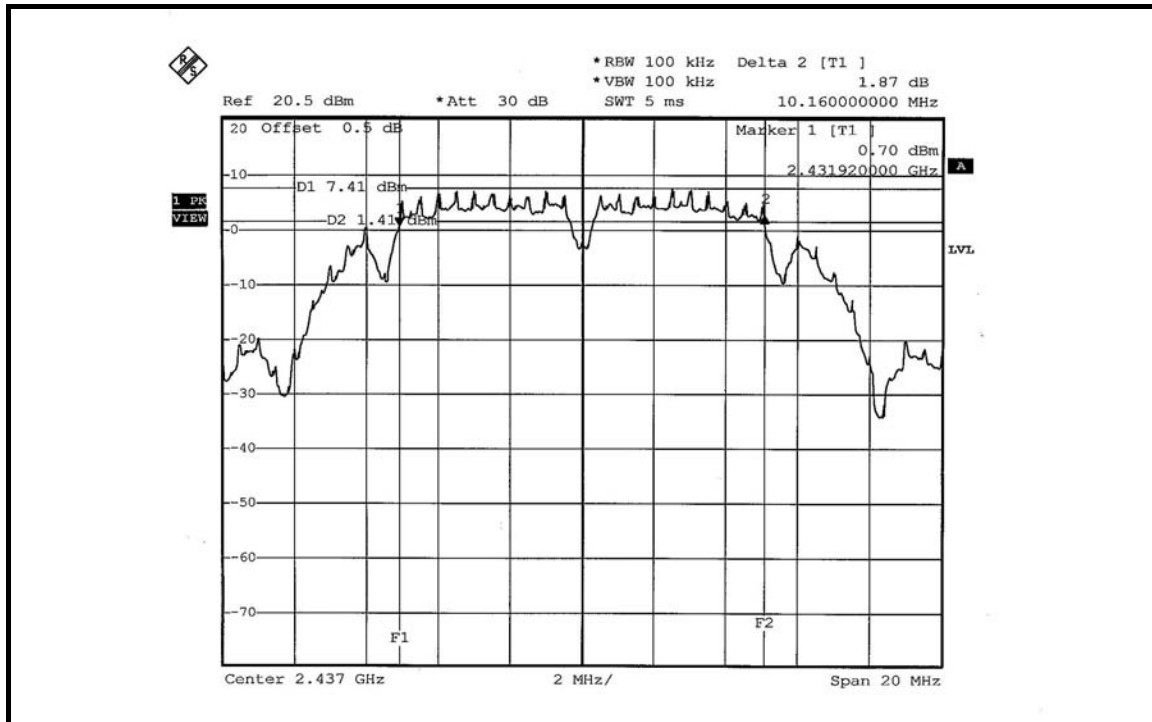

CH 11

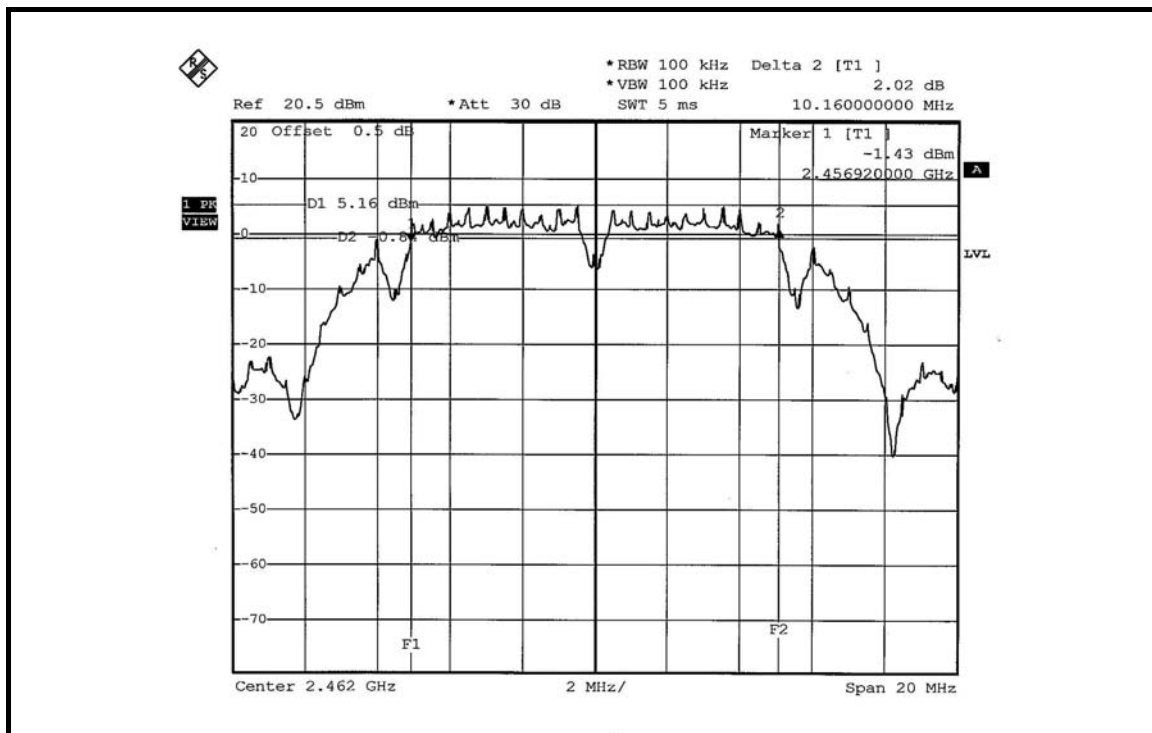

802.11g OFDM MODULATION:

MODULATION TYPE	BPSK	TRANSFER RATE	6Mbps
INPUT POWER (SYSTEM)	120Vac, 60 Hz	ENVIRONMENTAL CONDITIONS	25deg.C, 63%RH, 991hPa
TESTED BY	Match Tsui		

CHANNEL	CHANNEL FREQUENCY (MHz)	6dB BANDWIDTH (MHz)	MINIMUM LIMIT (MHz)	PASS / FAIL
1	2412	16.40	0.5	PASS
6	2437	16.36	0.5	PASS
11	2462	16.40	0.5	PASS

CH 1

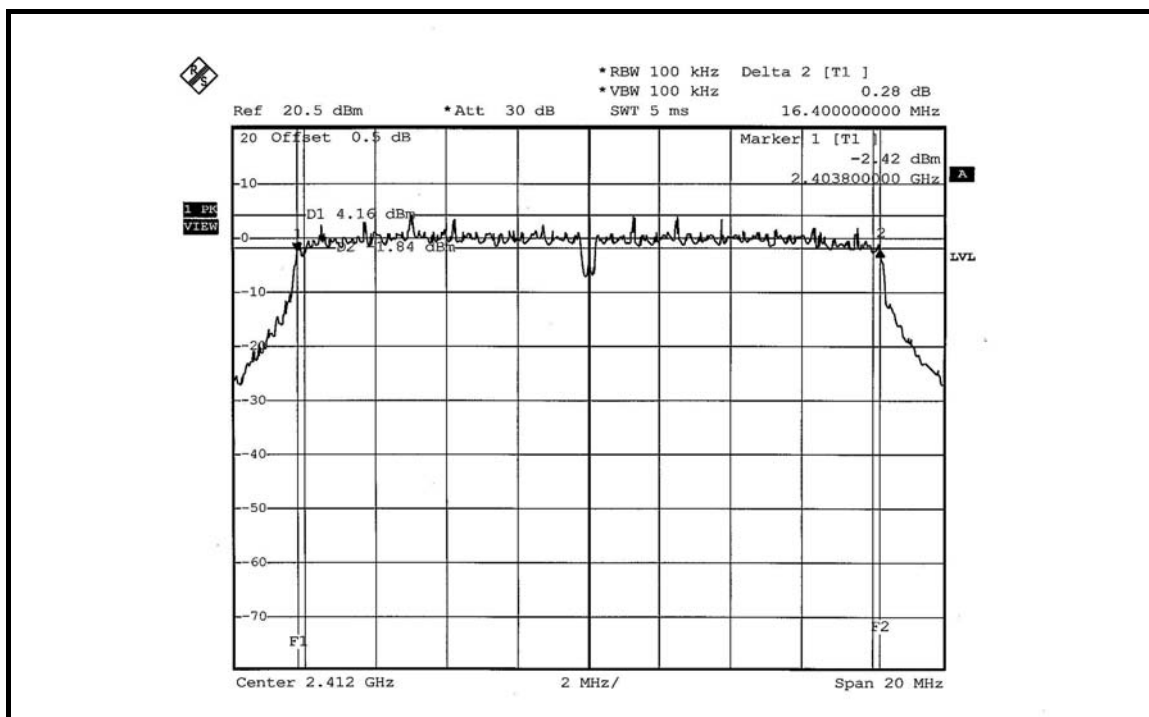

CH 6

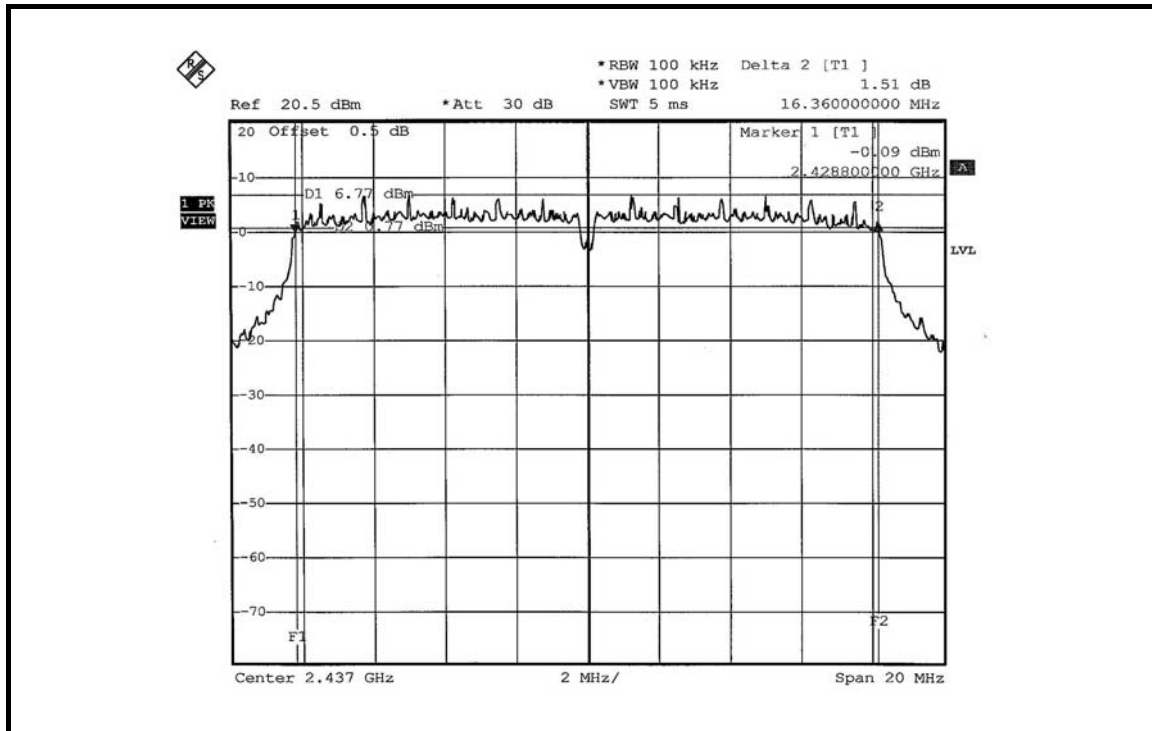

CH 11

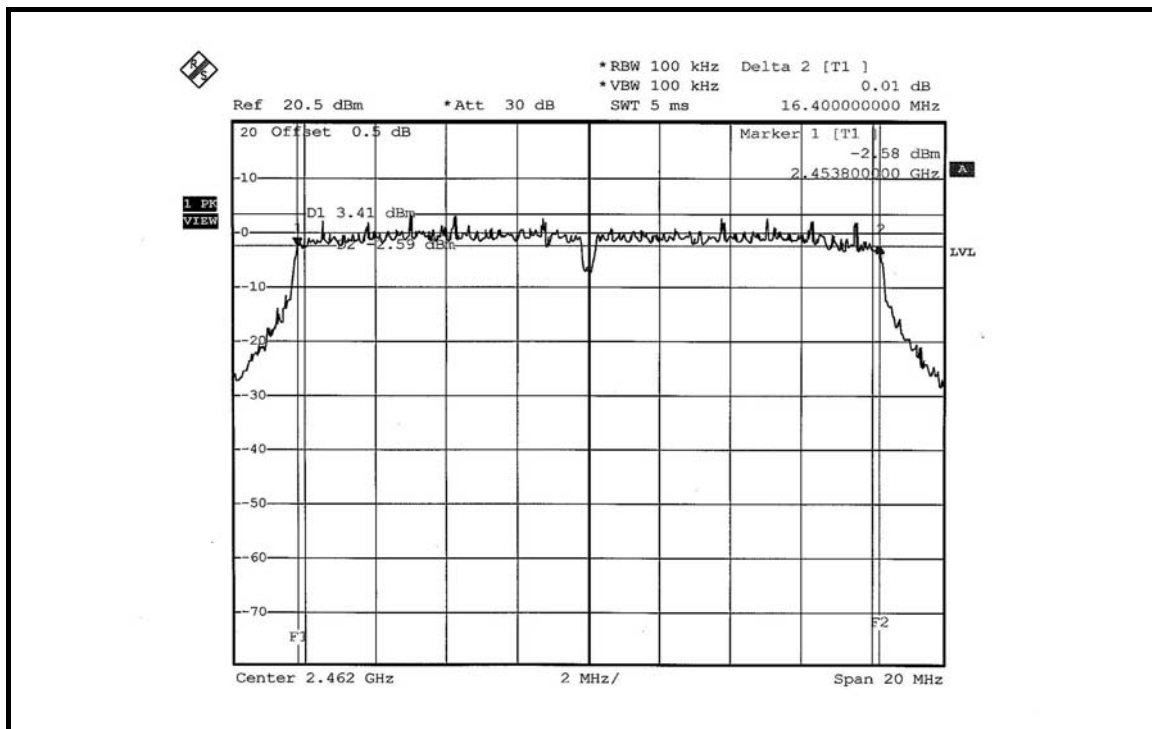



DRAFT 802.11n (20MHz) OFDM MODULATION: DUAL TX

MODULATION TYPE	BPSK	TRANSFER RATE	6.5Mbps
INPUT POWER (SYSTEM)	120Vac, 60 Hz	ENVIRONMENTAL CONDITIONS	25deg.C, 63%RH, 991hPa
TESTED BY	Match Tsui		

CHANNEL	CHANNEL FREQUENCY (MHz)	6dB BANDWIDTH (MHz)		MINIMUM LIMIT (MHz)	PASS / FAIL
		CHAIN 0	CHAIN 1		
1	2412	16.96	16.56	0.5	PASS
6	2437	16.48	17.00	0.5	PASS
11	2462	16.96	16.92	0.5	PASS

FOR CHAIN 0: CH 1

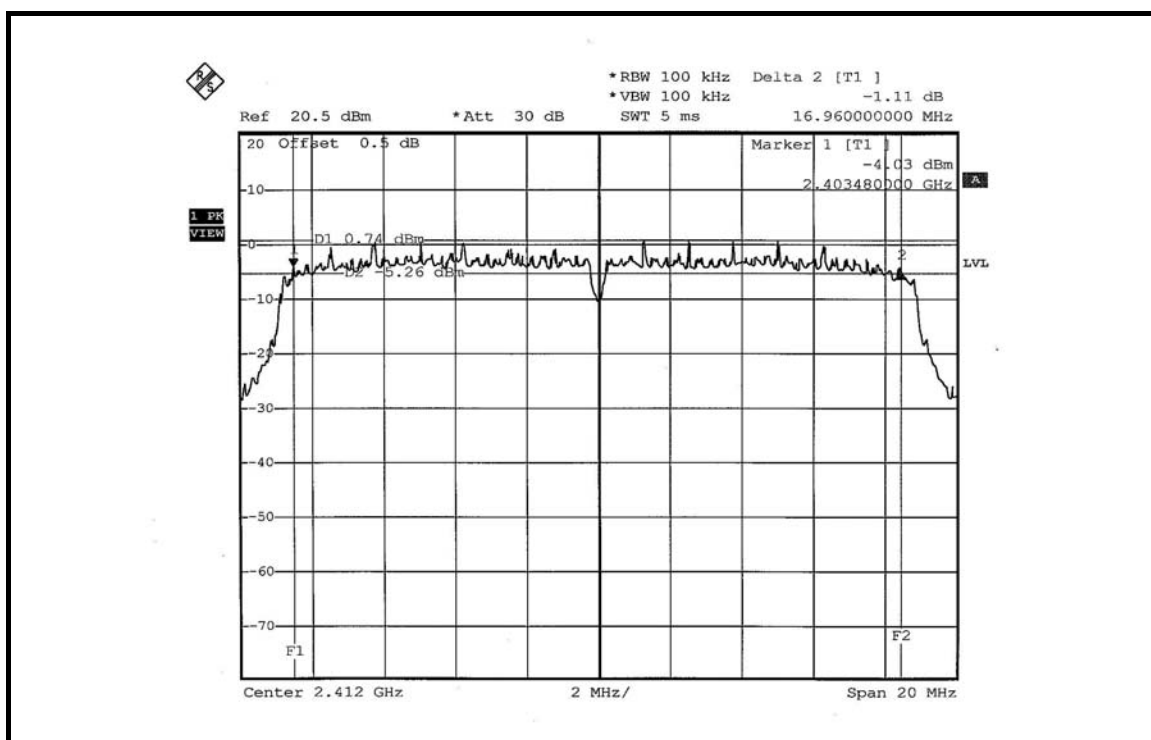

CH 6

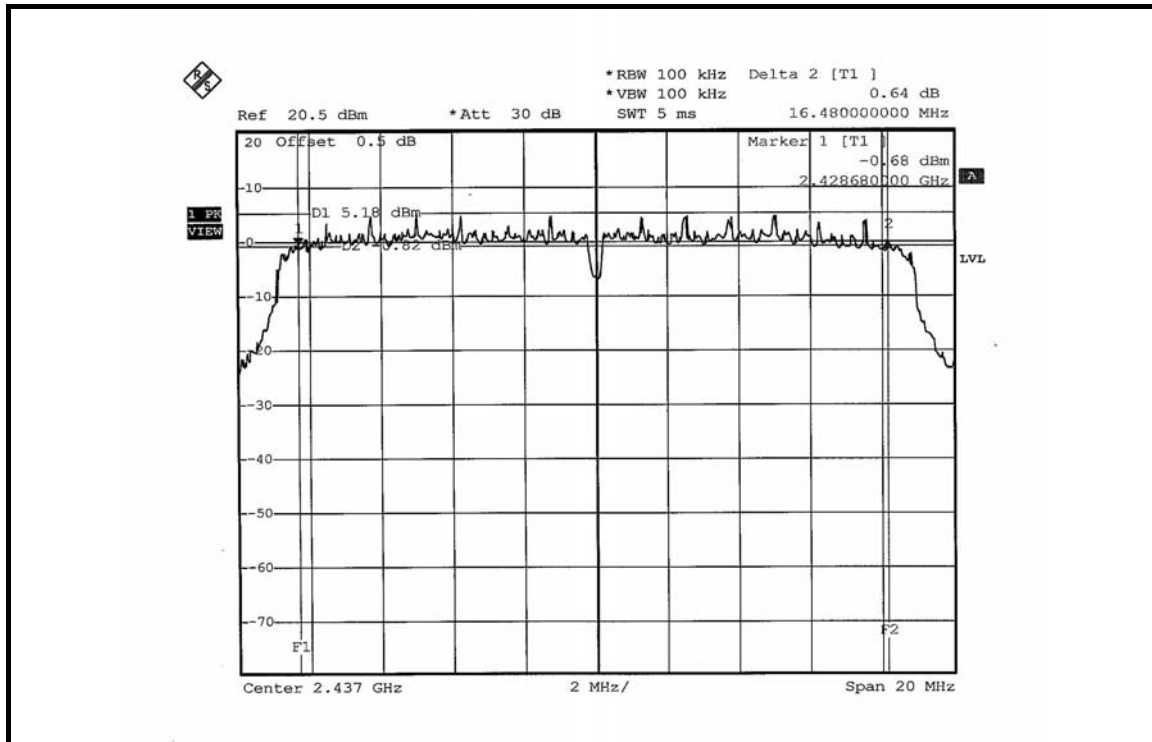

CH 11

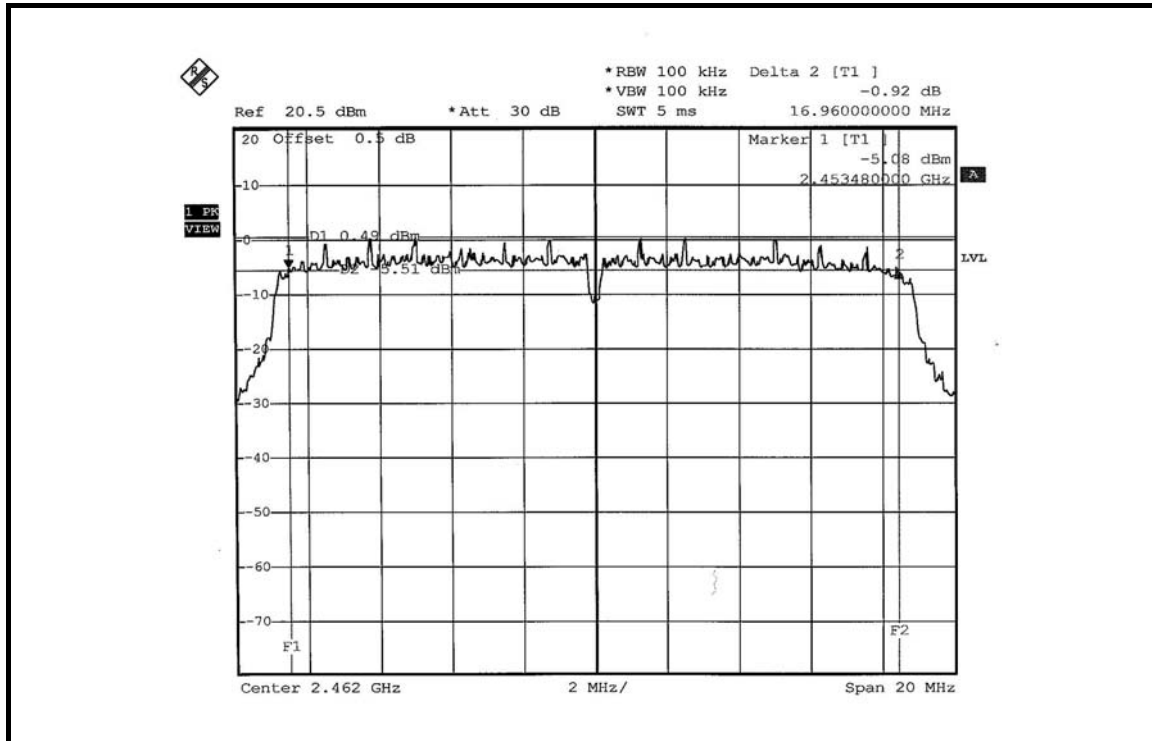

FOR CHAIN 1: CH 1

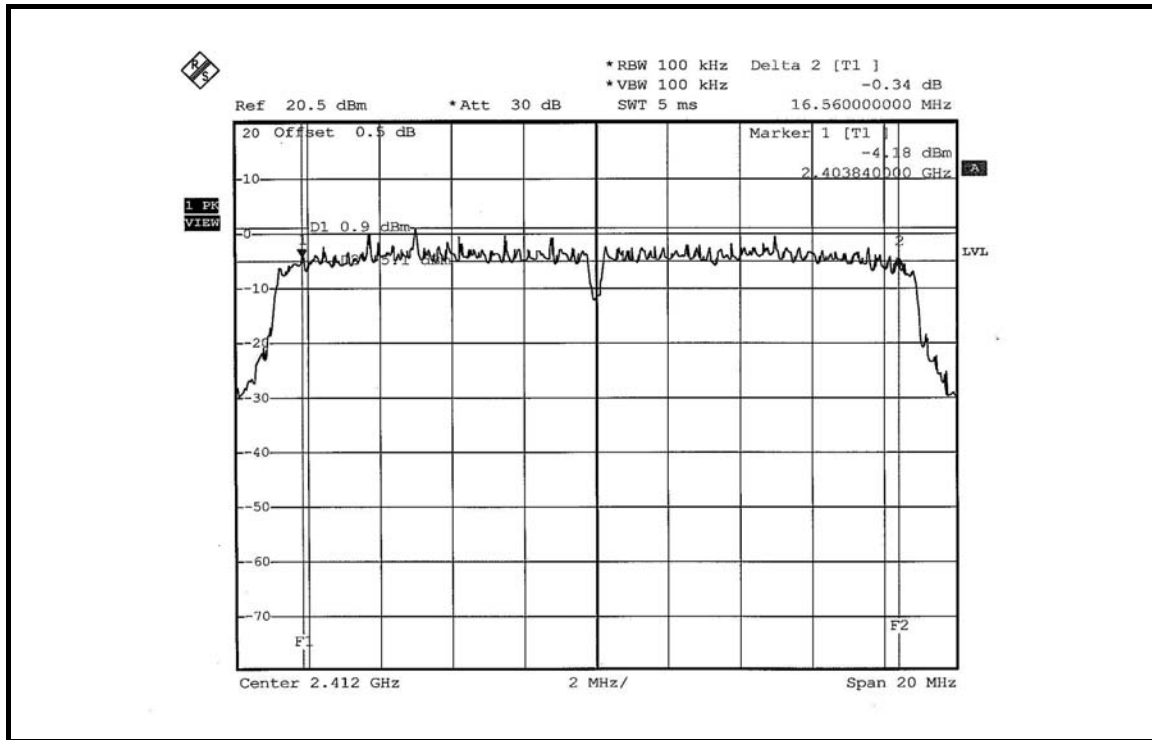

CH 6

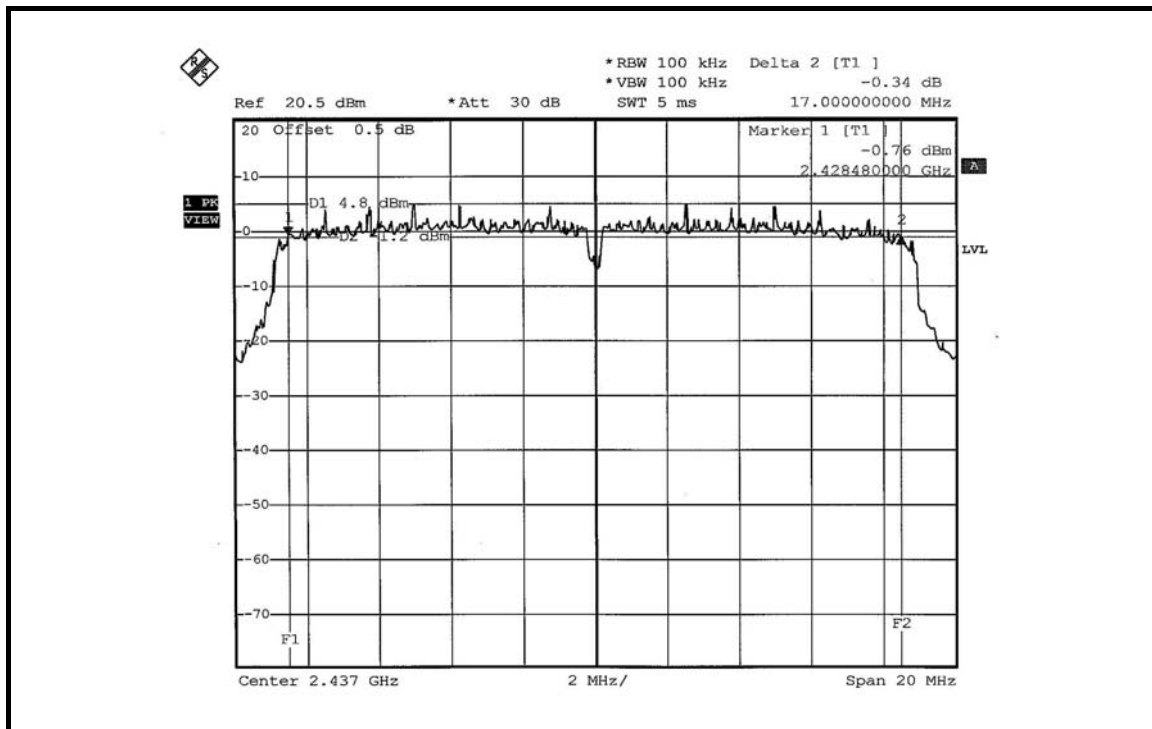

CH 11

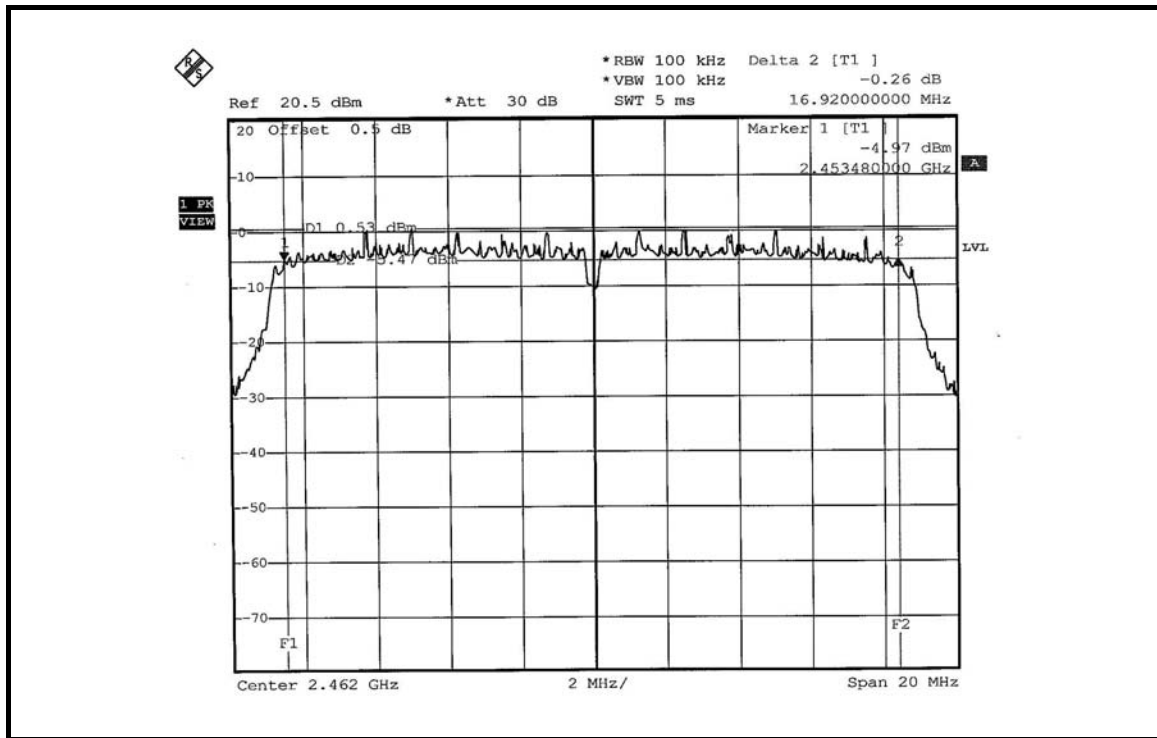



DRAFT 802.11n (40MHz) OFDM MODULATION: DUAL TX

MODULATION TYPE	BPSK	TRANSFER RATE	13.5Mbps
INPUT POWER (SYSTEM)	120Vac, 60 Hz	ENVIRONMENTAL CONDITIONS	25deg.C, 63%RH, 991hPa
TESTED BY	Match Tsui		

CHANNEL	CHANNEL FREQUENCY (MHz)	6dB BANDWIDTH (MHz)		MINIMUM LIMIT (MHz)	PASS / FAIL
		CHAIN 0	CHAIN 1		
1	2422	35.36	35.44	0.5	PASS
4	2437	34.64	35.76	0.5	PASS
7	2452	35.36	35.52	0.5	PASS

FOR CHAIN 0: CH 1

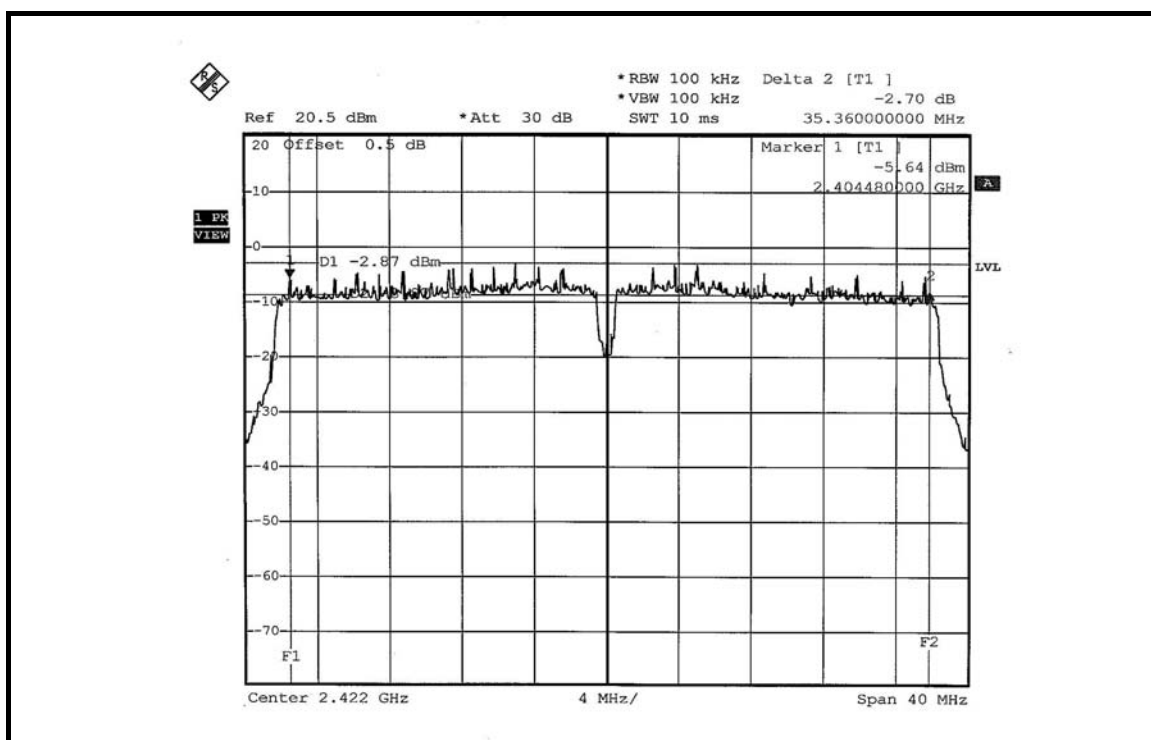

CH 4

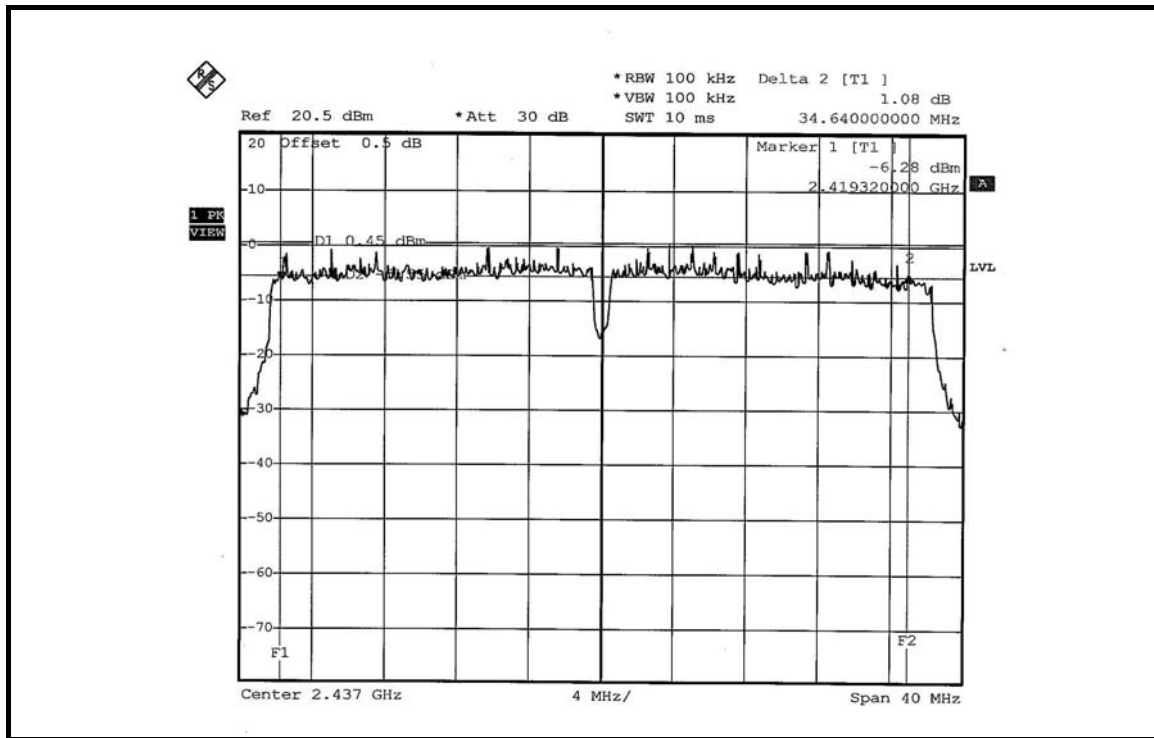

CH 7

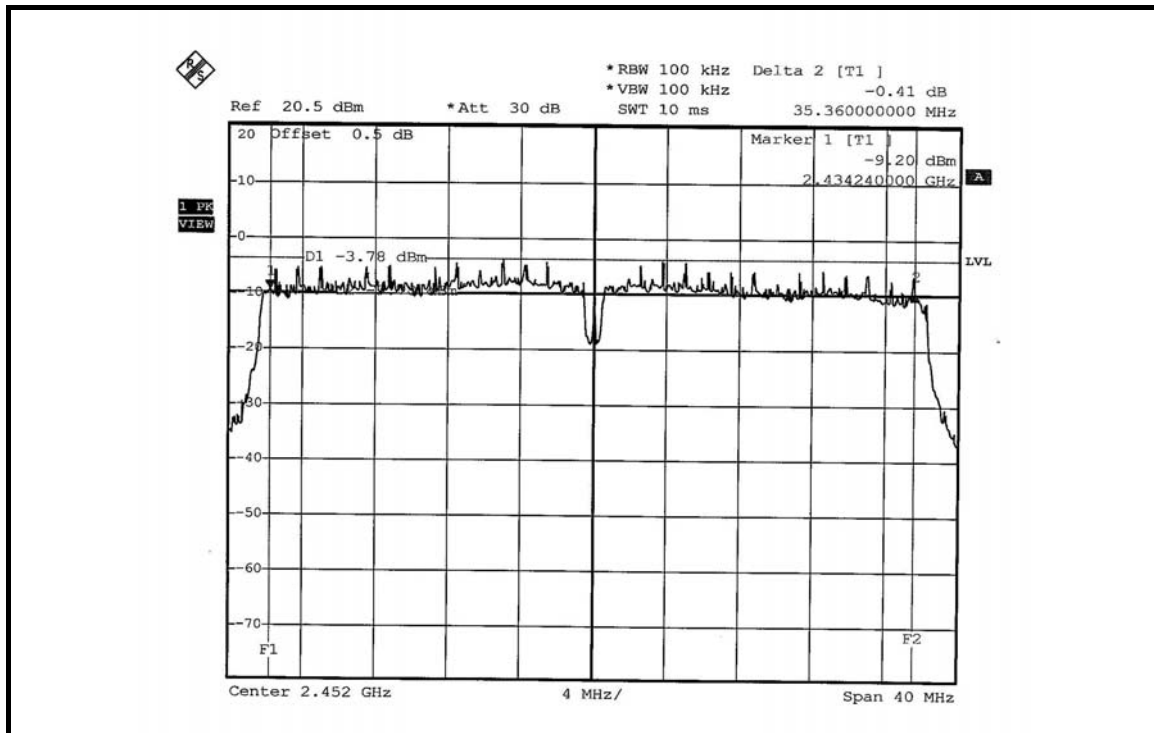

FOR CHAIN 1: CH 1

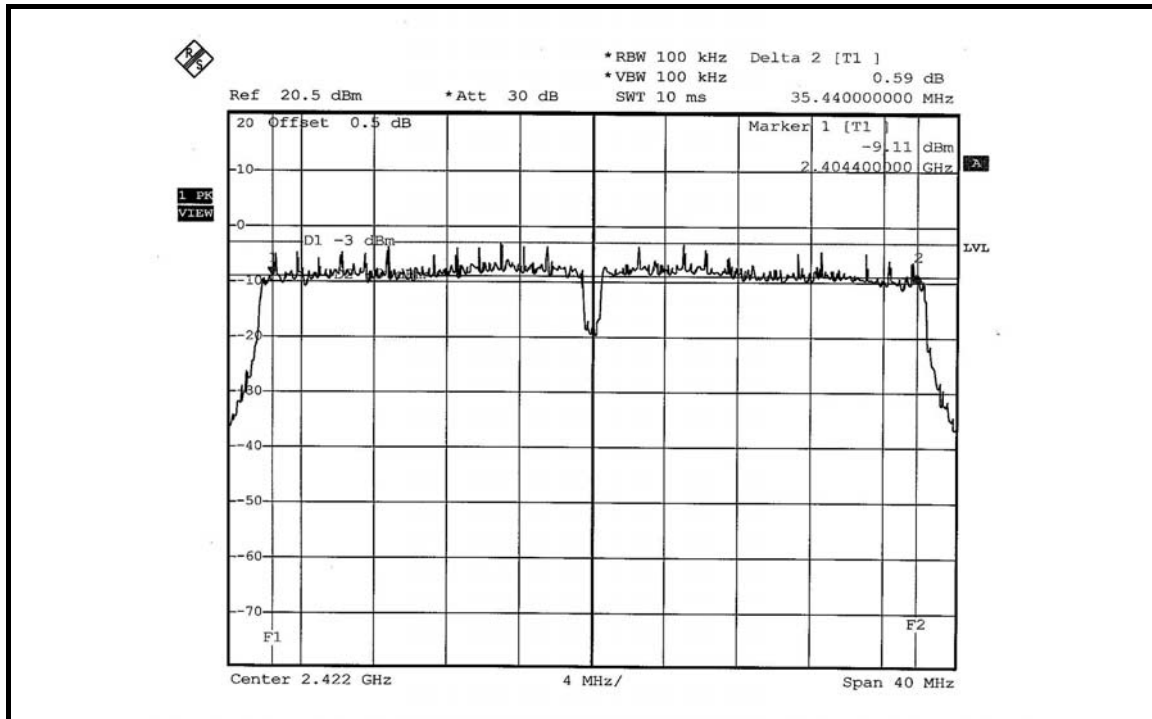

CH 4

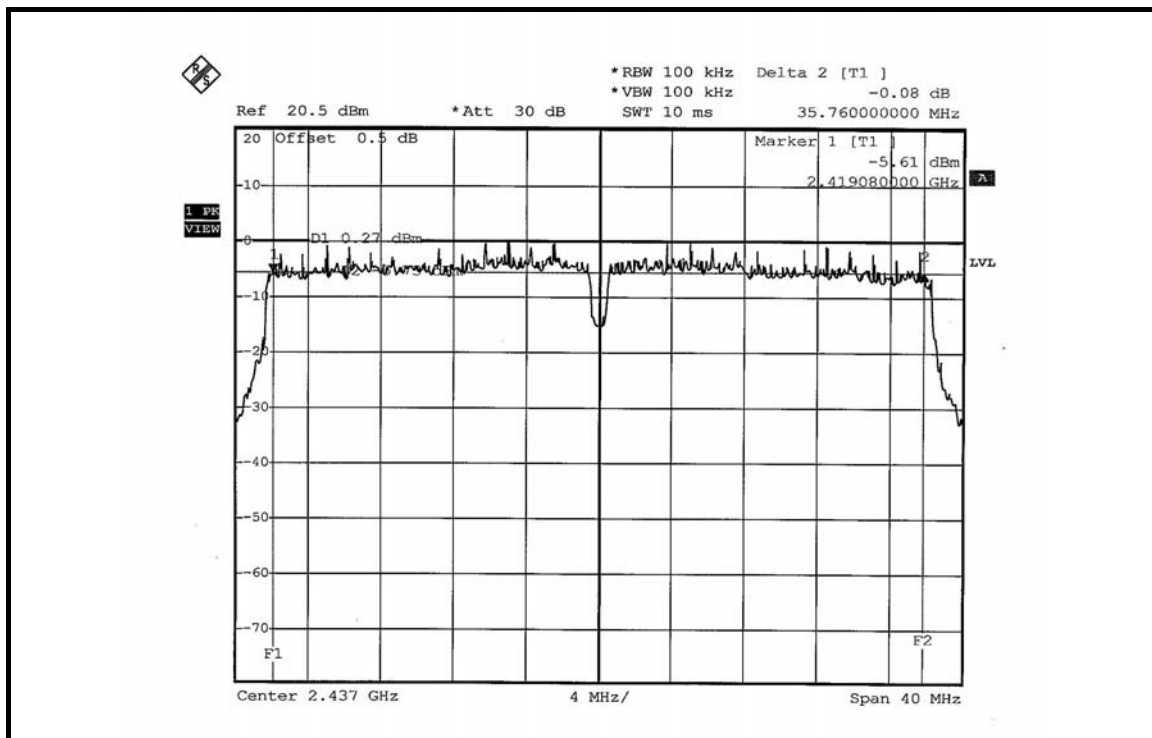

CH 7

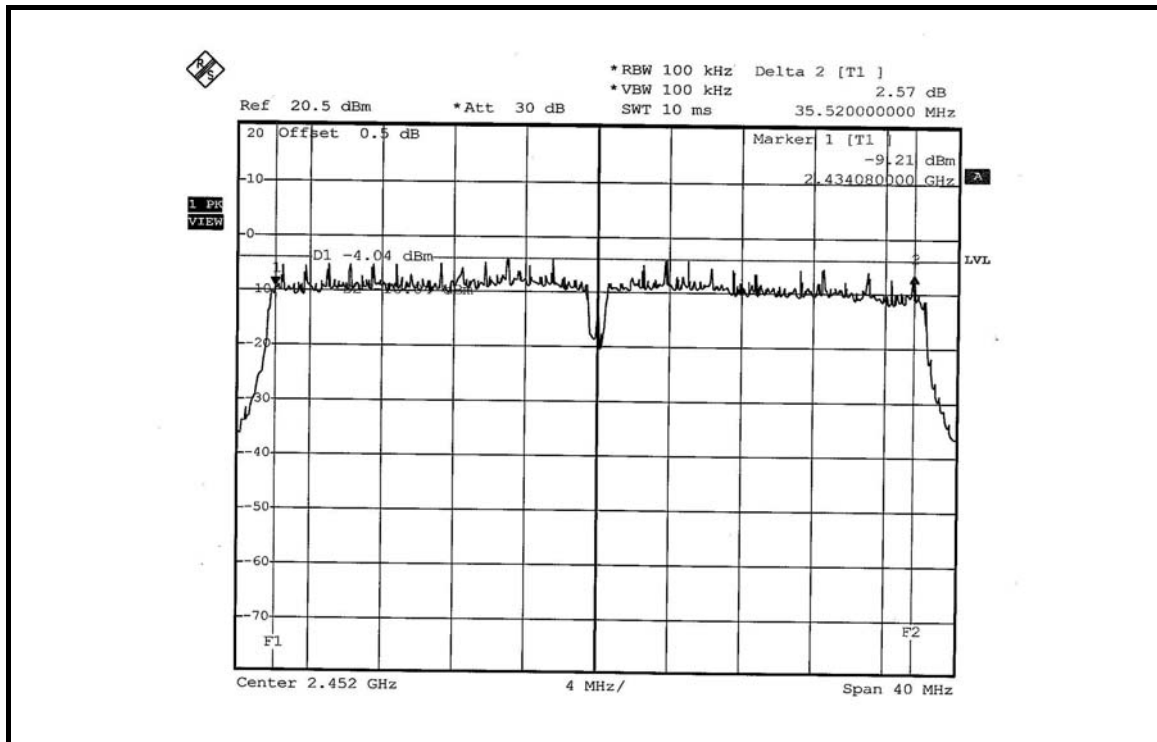



4.4 MAXIMUM PEAK OUTPUT POWER

4.4.1 LIMITS OF MAXIMUM PEAK OUTPUT POWER MEASUREMENT

The Maximum Peak Output Power Measurement is 30dBm.

4.4.2 INSTRUMENTS

DESCRIPTION & MANUFACTURER	MODEL NO.	SERIAL NO.	CALIBRATED UNTIL
R&S SPECTRUM ANALYZER	FSP 40	100040	Jun. 07, 2007
AGILENT SIGNAL GENERATOR	E8257C	MY43320668	Dec. 07, 2006
DIGITAL RT OSCILLOSCOPE	TDS1012	C037299	Nov. 28, 2006
NARDA DETECTOR	4503A	FSCM99899	NA

NOTE: The calibration interval of the above test instruments is 12 months and the calibrations are traceable to NML/ROC and NIST/USA.

4.4.3 TEST PROCEDURES

1. A detector was used on the output port of the EUT. An oscilloscope was used to read the response of the detector.
2. Replaced the EUT by the signal generator. The center frequency of the S.G was adjusted to the center frequency of the measured channel.
3. Adjusted the power to have the same reading on oscilloscope. Record the power level.

4.4.4 DEVIATION FROM TEST STANDARD

No deviation

4.4.5 TEST SETUP



4.4.6 EUT OPERATING CONDITIONS

Same as Item 4.3.6

4.4.7 TEST RESULTS

802.11b DSSS MODULATION:

MODULATION TYPE	DBPSK	TRANSFER RATE	1Mbps
INPUT POWER (SYSTEM)	120Vac, 60 Hz	ENVIRONMENTAL CONDITIONS	25deg.C, 63%RH, 991hPa
TESTED BY	Match Tsui		

CHANNEL	CHANNEL FREQUENCY (MHz)	PEAK POWER OUTPUT (mW)	PEAK POWER OUTPUT (dBm)	PEAK POWER LIMIT (dBm)	PASS / FAIL
1	2412	32.063	15.06	30	PASS
6	2437	50.816	17.06	30	PASS
11	2462	31.696	15.01	30	PASS

802.11g OFDM MODULATION:

MODULATION TYPE	BPSK	TRANSFER RATE	6Mbps
INPUT POWER (SYSTEM)	120Vac, 60 Hz	ENVIRONMENTAL CONDITIONS	25deg.C, 63%RH, 991hPa
TESTED BY	Match Tsui		

CHANNEL	CHANNEL FREQUENCY (MHz)	PEAK POWER OUTPUT (mW)	PEAK POWER OUTPUT (dBm)	PEAK POWER LIMIT (dBm)	PASS / FAIL
1	2412	45.604	16.59	30	PASS
6	2437	80.168	19.04	30	PASS
11	2462	40.644	16.09	30	PASS



DRAFT 802.11n (20MHz) OFDM MODULATION: DUAL TX

MODULATION TYPE	BPSK	TRANSFER RATE	6.5Mbps
INPUT POWER (SYSTEM)	120Vac, 60 Hz	ENVIRONMENTAL CONDITIONS	25deg.C, 63%RH, 991hPa
TESTED BY	Match Tsui		

CHANNEL	CHANNEL FREQUENCY (MHz)	PEAK POWER OUTPUT (mW)		PEAK POWER OUTPUT (dBm)		TOTAL PEAK POWER (mW)	TOTAL PEAK POWER (dBm)	PEAK POWER LIMIT (dBm)	PASS / FAIL
		CHAIN 0	CHAIN 1	CHAIN 0	CHAIN 1				
1	2412	32.137	31.696	15.07	15.01	63.833	18.05	30	PASS
6	2437	80.168	79.983	19.04	19.03	160.151	22.05	30	PASS
11	2462	28.708	28.510	14.58	14.55	57.218	17.58	30	PASS

DRAFT 802.11n (40MHz) OFDM MODULATION: DUAL TX

MODULATION TYPE	BPSK	TRANSFER RATE	13.5Mbps
INPUT POWER (SYSTEM)	120Vac, 60 Hz	ENVIRONMENTAL CONDITIONS	25deg.C, 63%RH, 991hPa
TESTED BY	Match Tsui		

CHANNEL	CHANNEL FREQUENCY (MHz)	PEAK POWER OUTPUT (mW)		PEAK POWER OUTPUT (dBm)		TOTAL PEAK POWER (mW)	TOTAL PEAK POWER (dBm)	PEAK POWER LIMIT (dBm)	PASS / FAIL
		CHAIN 0	CHAIN 1	CHAIN 0	CHAIN 1				
1	2422	20.091	20.091	13.03	13.03	40.182	16.04	30	PASS
4	2437	40.551	39.994	16.08	16.02	80.545	19.06	30	PASS
7	2452	16.106	15.959	12.07	12.03	32.065	15.06	30	PASS



4.5 POWER SPECTRAL DENSITY MEASUREMENT

4.5.1 LIMITS OF POWER SPECTRAL DENSITY MEASUREMENT

The Maximum of Power Spectral Density Measurement is 8dBm.

4.5.2 TEST INSTRUMENTS

DESCRIPTION & MANUFACTURER	MODEL NO.	SERIAL NO.	CALIBRATED UNTIL
R&S SPECTRUM ANALYZER	FSP 40	100040	Jun. 07, 2007

NOTE: The calibration interval of the above test instruments is 12 months and the calibrations are traceable to NML/ROC and NIST/USA.

4.5.3 TEST PROCEDURE

The transmitter output was connected to the spectrum analyzer through an attenuator, the bandwidth of the fundamental frequency was measured with the spectrum analyzer using 3kHz RBW and 30kHz VBW, set sweep time = span/3kHz. The power spectral density was measured and recorded.

The sweep time is allowed to be longer than span/3kHz for a full response of the mixer in the spectrum analyzer.

4.5.4 DEVIATION FROM TEST STANDARD

No deviation

4.5.5 TEST SETUP

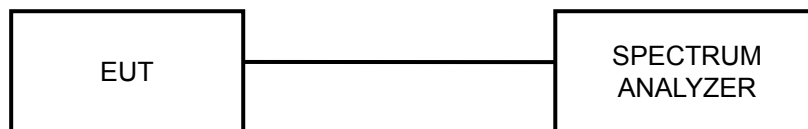

4.5.6 EUT OPERATING CONDITION

Same as Item 4.3.6

4.5.7 TEST RESULTS

802.11b DSSS MODULATION:

MODULATION TYPE	DBPSK	TRANSFER RATE	1Mbps
INPUT POWER (SYSTEM)	120Vac, 60 Hz	ENVIRONMENTAL CONDITIONS	25deg.C, 63%RH, 991hPa
TESTED BY	Match Tsui		

CHANNEL	CHANNEL FREQUENCY (MHz)	RF POWER LEVEL IN 3kHz BW (dBm)	MAXIMUM LIMIT (dBm)	PASS / FAIL
1	2412	-8.98	8	PASS
6	2437	-6.75	8	PASS
11	2462	-8.81	8	PASS

CH 1

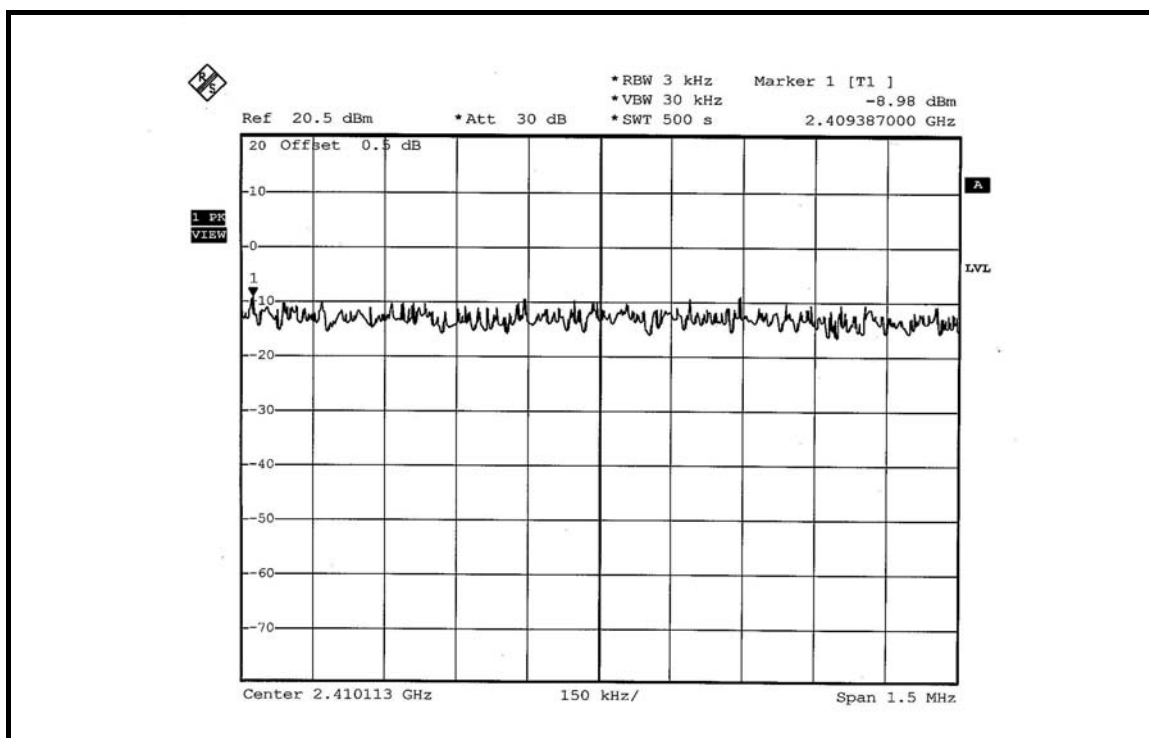

CH 6

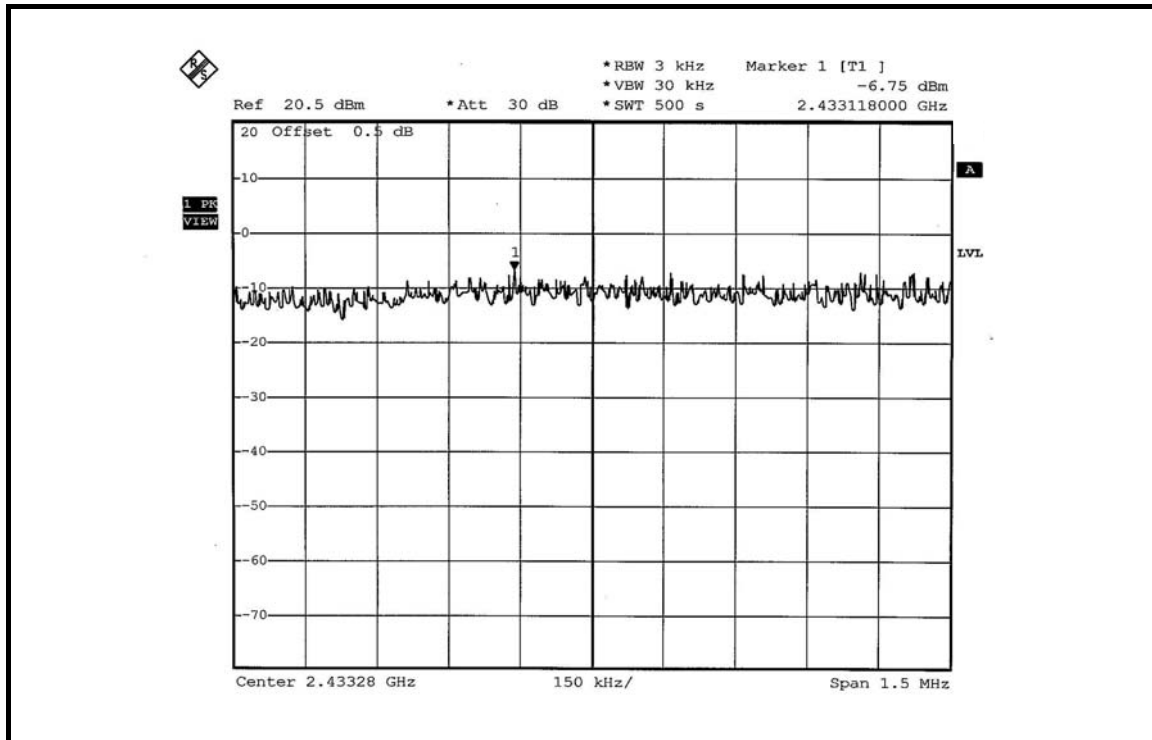

CH 11

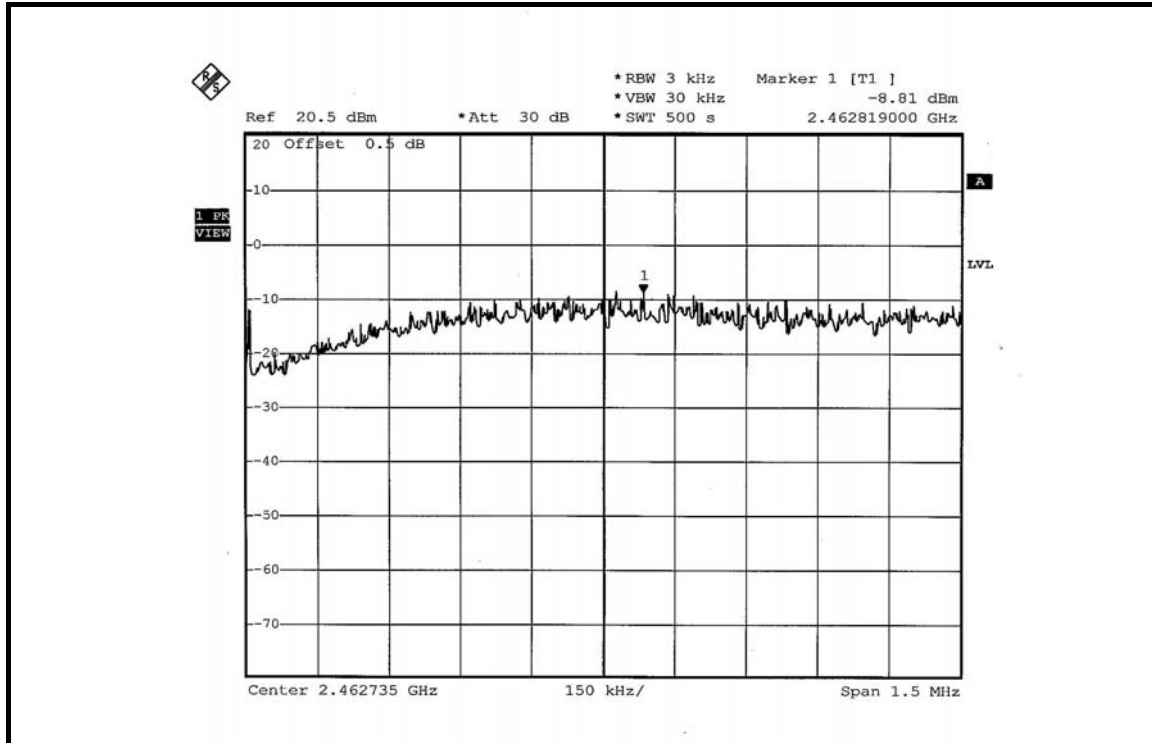

802.11g OFDM MODULATION:

MODULATION TYPE	BPSK	TRANSFER RATE	6Mbps
INPUT POWER (SYSTEM)	120Vac, 60 Hz	ENVIRONMENTAL CONDITIONS	25deg.C, 63%RH, 991hPa
TESTED BY	Match Tsui		

CHANNEL	CHANNEL FREQUENCY (MHz)	RF POWER LEVEL IN 3kHz BW (dBm)	MAXIMUM LIMIT (dBm)	PASS / FAIL
1	2412	-8.90	8	PASS
6	2437	-5.91	8	PASS
11	2462	-8.96	8	PASS

CH 1

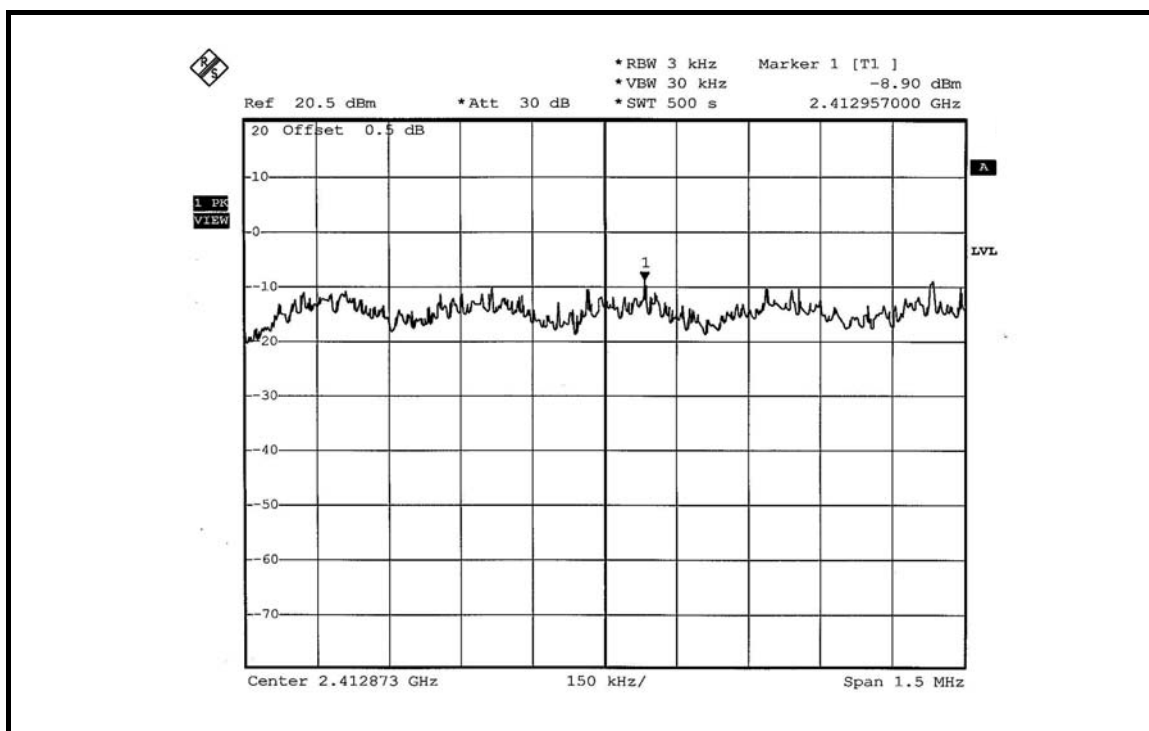

CH 6

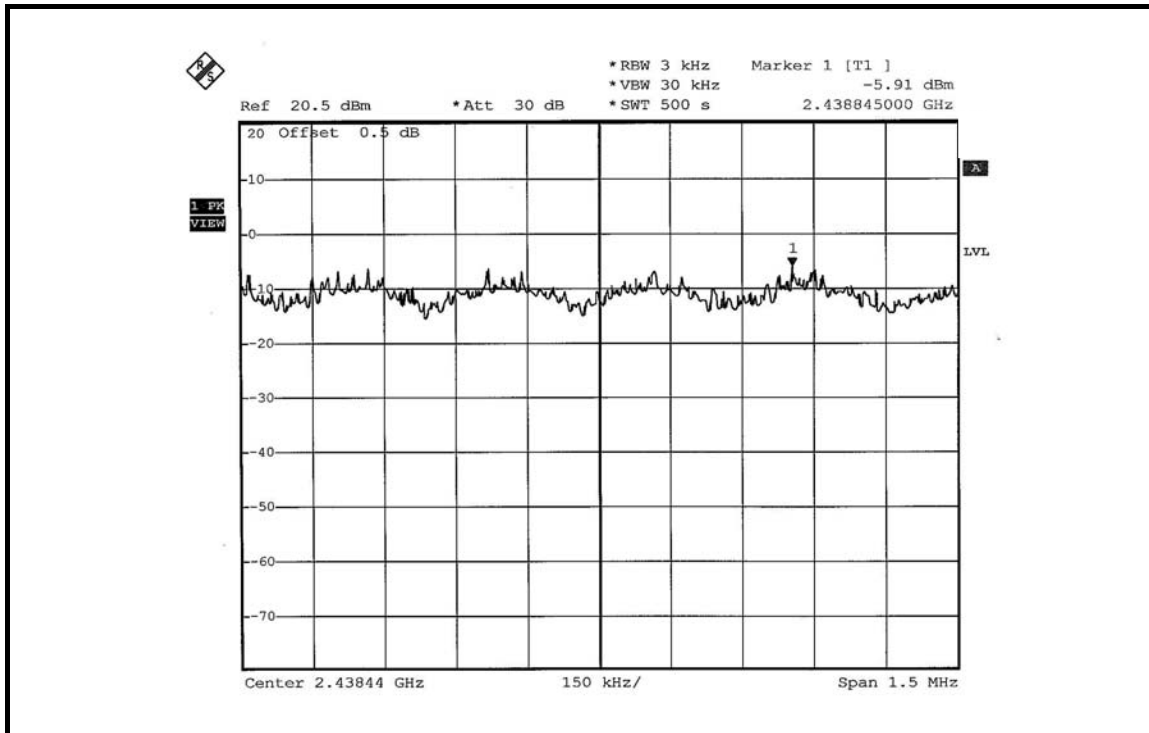

CH 11

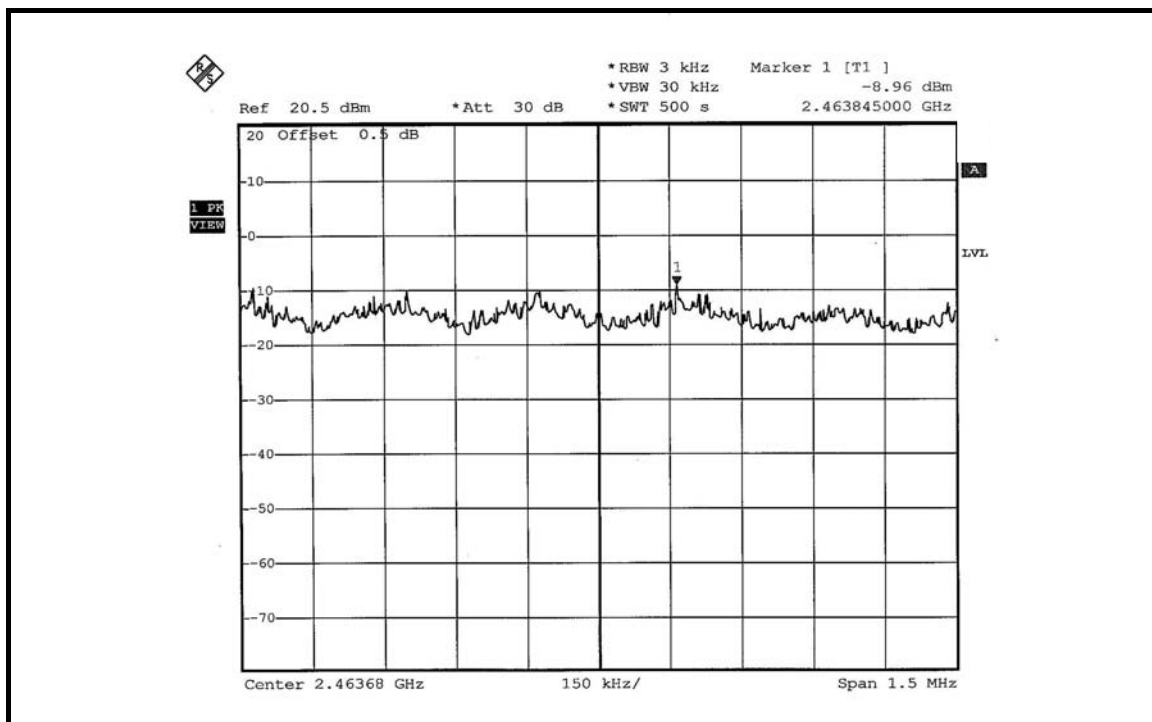



DRAFT 802.11n (20MHz) OFDM MODULATION: DUAL TX

MODULATION TYPE	BPSK	TRANSFER RATE	6.5Mbps
INPUT POWER (SYSTEM)	120Vac, 60 Hz	ENVIRONMENTAL CONDITIONS	25deg.C, 63%RH, 991hPa
TESTED BY	Match Tsui		

CHANNEL	CHANNEL FREQUENCY (MHz)	RF POWER LEVEL IN 3kHz BW (mW)		RF POWER LEVEL IN 3kHz BW (dBm)		TOTAL POWER DENSITY (mW)	TOTAL POWER DENSITY (dBm)	MAX. LIMIT (dBm)	PASS / FAIL
		CHAIN 0	CHAIN 1	CHAIN 0	CHAIN 1				
1	2412	0.064	0.062	-11.95	-12.07	0.126	-9.00	8	PASS
6	2437	0.157	0.166	-8.05	-7.81	0.323	-4.92	8	PASS
11	2462	0.055	0.057	-12.60	-12.45	0.112	-9.51	8	PASS

FOR CHAIN 0: CH 1

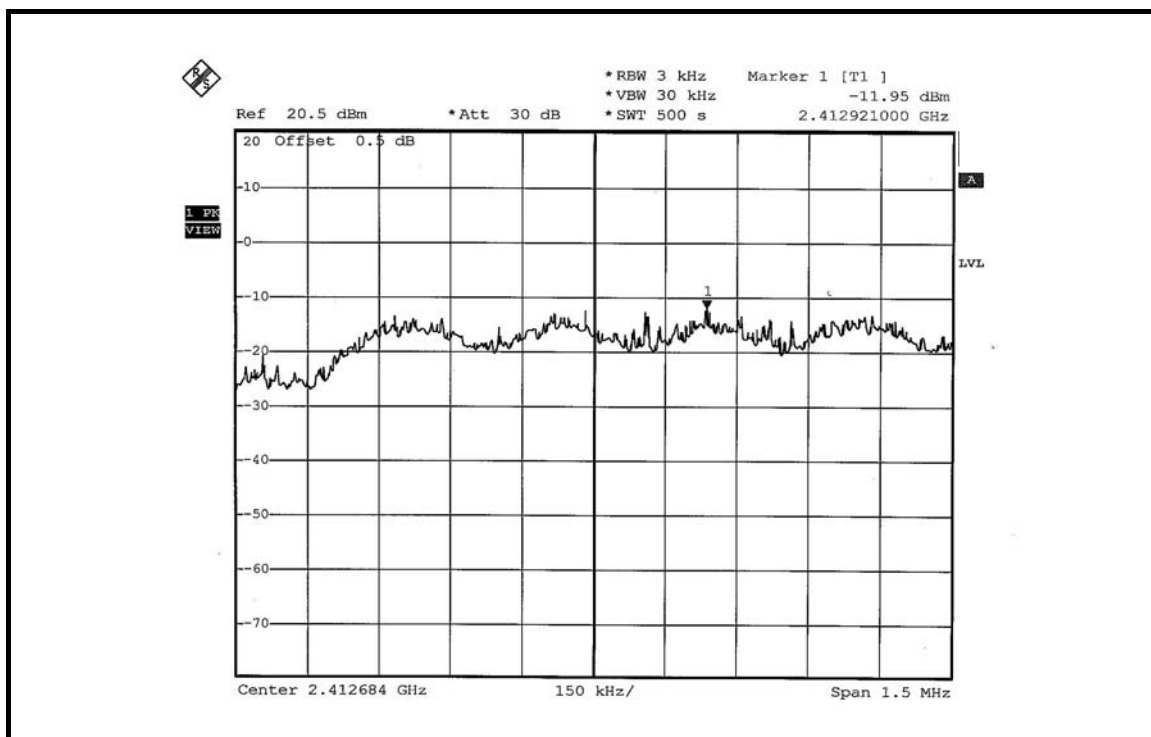

CH 6

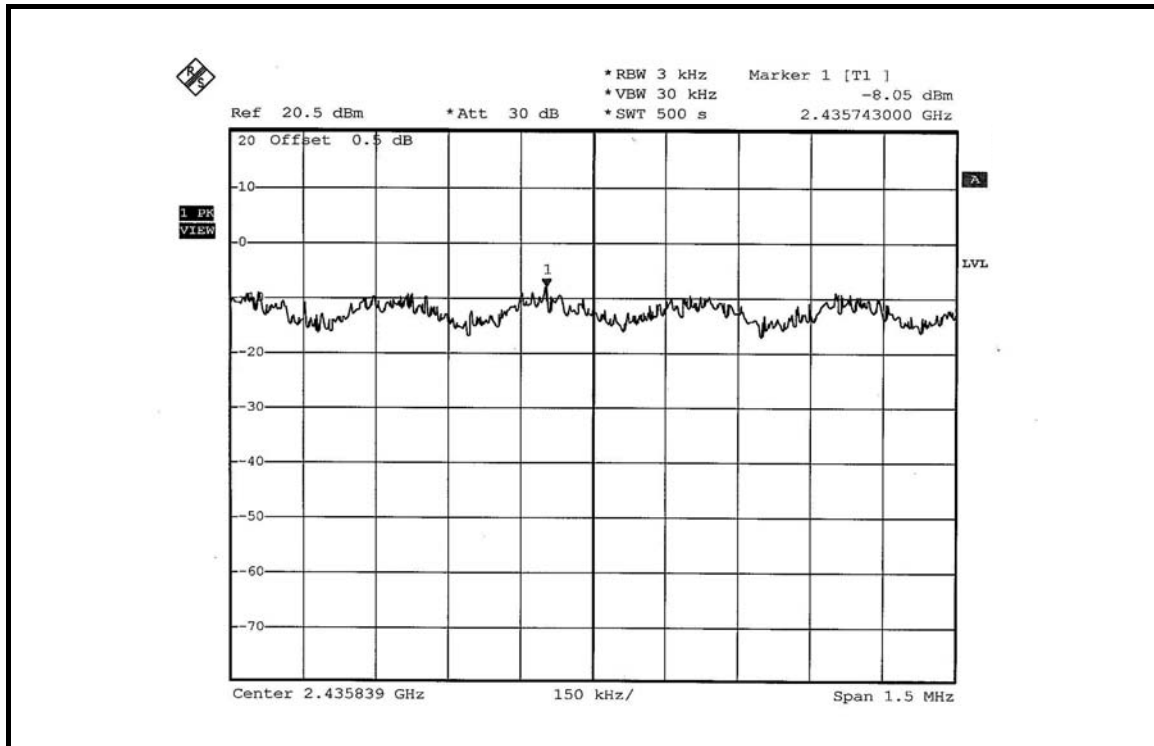

CH 11

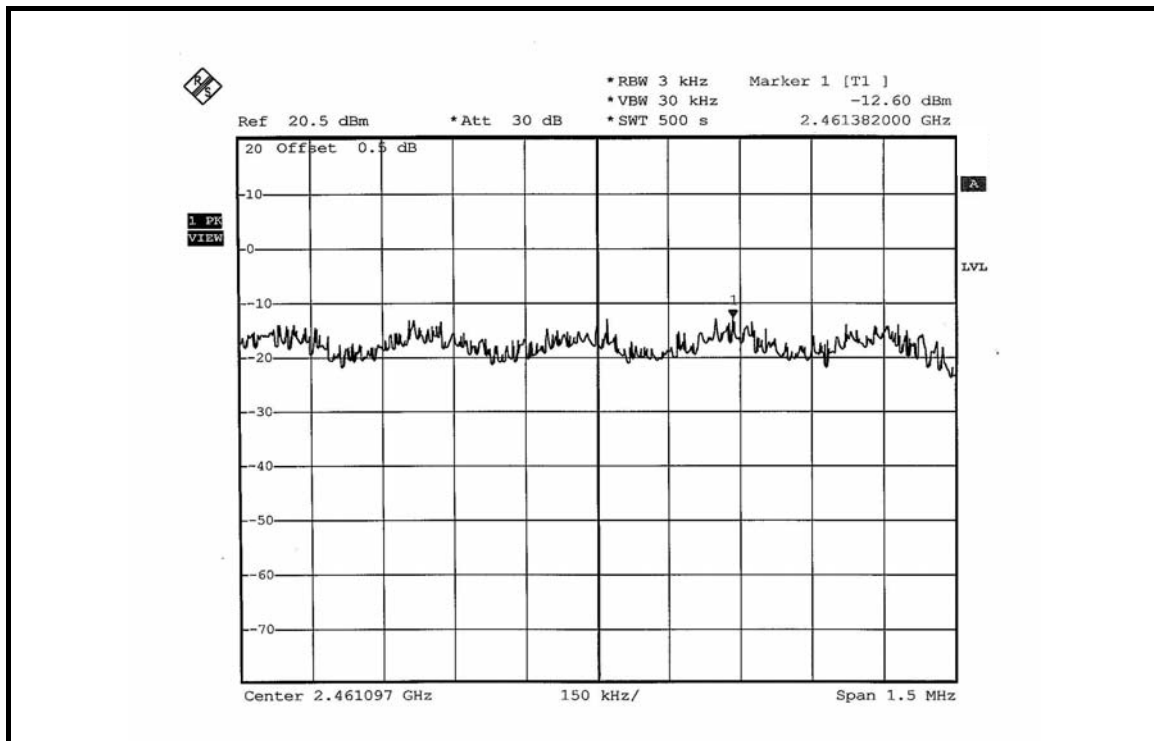

FOR CHAIN 1: CH 1

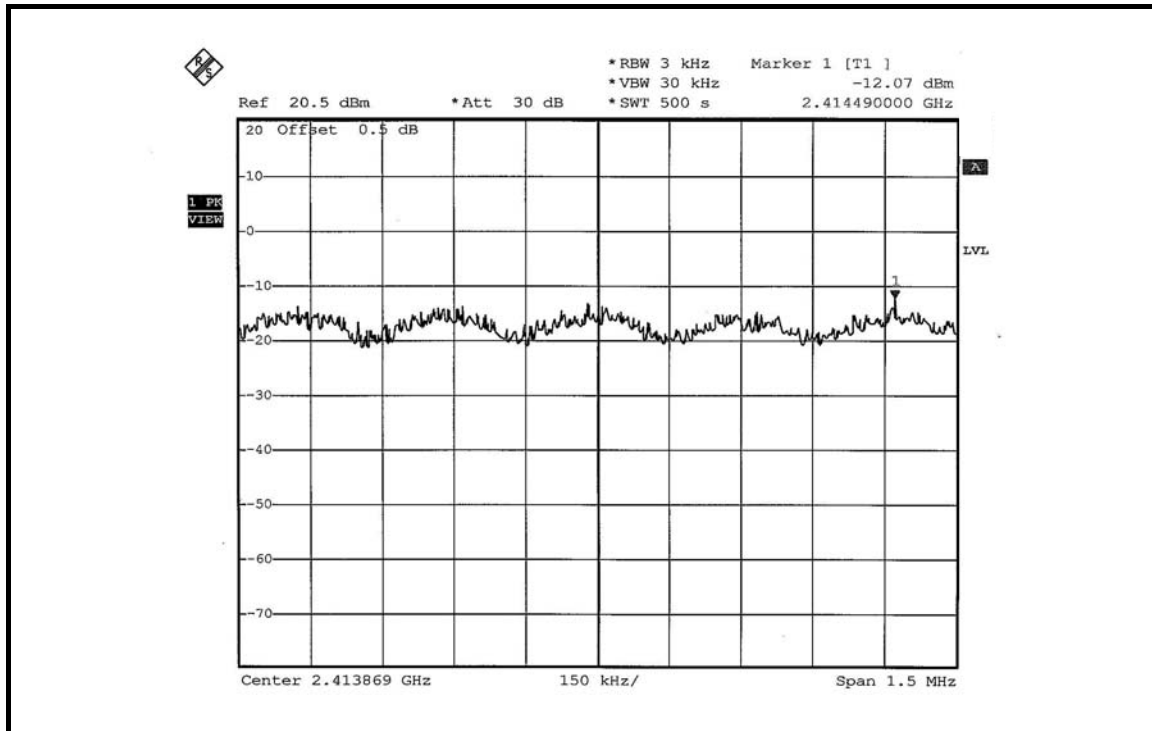

CH 6

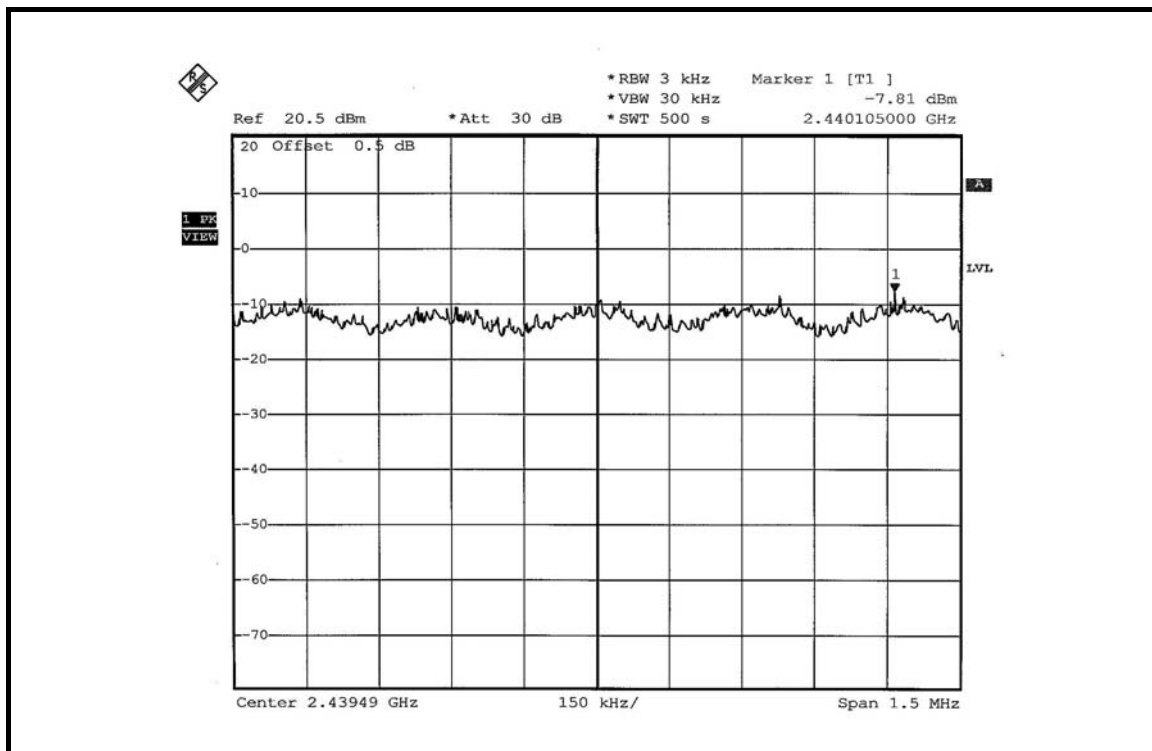

CH 11

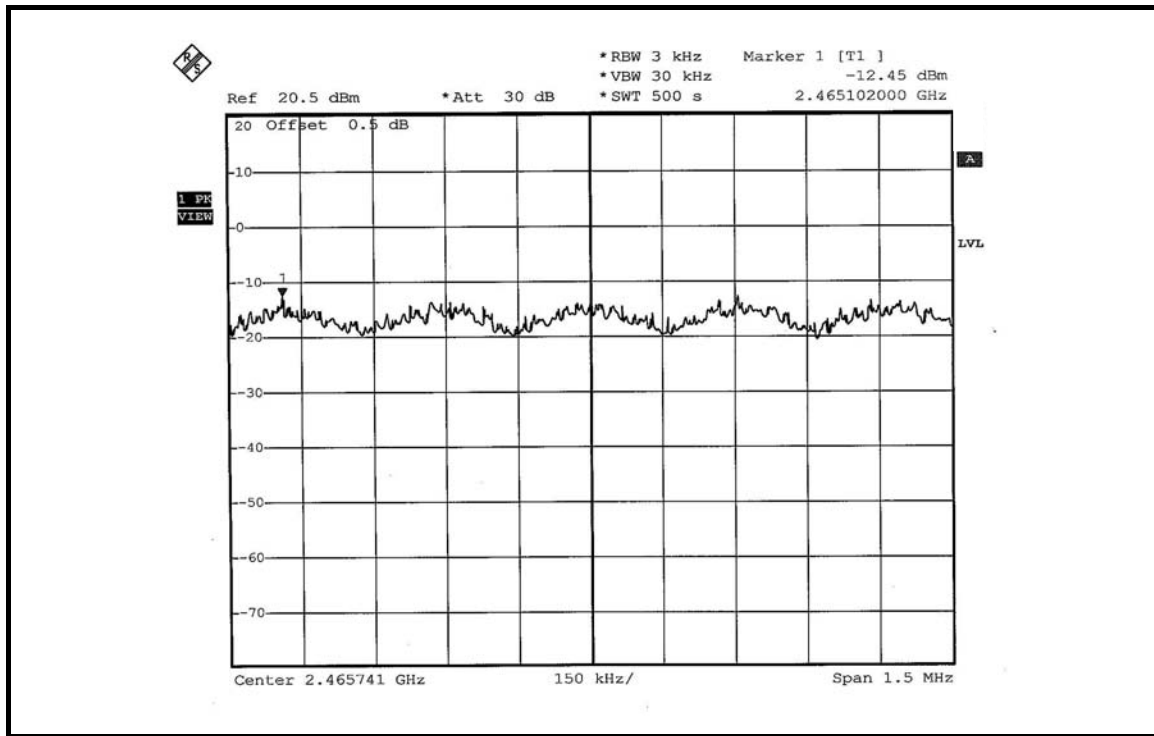



DRAFT 802.11n (40MHz) OFDM MODULATION: DUAL TX

MODULATION TYPE	BPSK	TRANSFER RATE	13.5Mbps
INPUT POWER (SYSTEM)	120Vac, 60 Hz	ENVIRONMENTAL CONDITIONS	25deg.C, 63%RH, 991hPa
TESTED BY	Match Tsui		

CHANNEL	CHANNEL FREQUENCY (MHz)	RF POWER LEVEL IN 3kHz BW (mW)		RF POWER LEVEL IN 3kHz BW (dBm)		TOTAL POWER DENSITY (mW)	TOTAL POWER DENSITY (dBm)	MAX. LIMIT (dBm)	PASS / FAIL
		CHAIN 0	CHAIN 1	CHAIN 0	CHAIN 1				
1	2422	0.016	0.016	-17.86	-17.97	0.032	-14.90	8	PASS
4	2437	0.033	0.032	-14.76	-14.95	0.065	-11.84	8	PASS
7	2452	0.013	0.013	-18.78	-18.71	0.026	-15.73	8	PASS

FOR CHAIN 0: CH 1

