

E055-71520325  
E055-71520330

*2 or 4 pipe configurable,  
3 speed fan control*

*Wi-Fi onboard*

*Switchable, non-programmable  
or 7 day programmable*

*Free mobile app and website  
for easy remote control*

*Setpoint Limiting and/or  
total keypad lockout*

*Auto-Changeover\**

*Dry contact for condensate  
overflow or occupancy sensors*

*Can control dual chilled water  
valves for dehumidification*

*Override capable*

*Pre-occupancy fan purge*

*California Title 24 Compliant*

*OpenADR 2.0b Certified*



## 2 or 4 pipe system Fan Coil Digital Thermostat with Wi-Fi and Local API



THE WORLD LEADER IN FAN COIL SOLUTIONS

*\* Auto-changeover is available in 4-pipe systems, in 2-pipe systems with Electric Heat, or when used with G100-71520306 accessory, auto-changeover sensor.*

# Owner's Manual & Installation Instructions



## CAUTION

Follow the [Installation Instructions](#) before proceeding. Set the thermostat mode to “OFF” prior to changing settings in setup or restoring Factory Defaults.

---

### FCC Compliance Statement

This equipment has been tested and found to comply with the limits for a Class B digital device, pursuant to part 15 of the FCC Rules. These limits are designed to provide reasonable protection against harmful interference in a residential installation. This equipment generates, uses and can radiate radio frequency energy and, if not installed and used in accordance with the instructions, may cause harmful interference to radio communications. However, there is no guarantee that interference will not occur in a particular installation. If this equipment does cause harmful interference to radio or television reception, which can be determined by turning the equipment off and on, the user is encouraged to try to correct the interference by one or more of the following measures:

- Reorient or relocate the receiving antenna.
- Increase the separation between the equipment and receiver.
- Connect the equipment into an outlet on a circuit different from that of the receiver.
- Consult the dealer or an experienced radio or TV technician for help.

Notice: Only peripherals complying with FCC limits may be attached to this equipment. Operation with noncompliant peripherals or peripherals not recommended by Venstar, is likely to result in interference to radio and TV reception. Changes or modifications to the product, not expressly approved by Venstar could void the user’s authority to operate the equipment.

### FCC - INDOOR Mobile Radio Information:

To comply with FCC/IC RF exposure limits for general population / uncontrolled exposure, the antenna(s) used for this transmitter must be installed to provide a separation distance of at least 20 cm from all persons and must not be co-located or operating in conjunction with any other antenna or transmitter.

This Device complies with Industry Canada License-exempt RSS standard(s). Operation is subject to the following two conditions: 1) this device may not cause interference, and 2) this device must accept any interference, including interference that may cause undesired operation of the device.

Under Industry Canada regulations, this radio transmitter may only operate using an antenna of a type and maximum (or lesser) gain approved for the transmitter by Industry Canada. To reduce potential radio interference to other users, the antenna type and its gain should be so chosen that the equivalent isotropically radiated power (e.i.r.p.) is not more than that necessary for successful communication.

*Cet appareil est conforme avec Industrie Canada, exempts de licence standard RSS(s). Son fonctionnement est soumis aux deux conditions suivantes: 1) ce dispositif ne doit pas causer d'interférences, et 2) ce dispositif doit accepter toute interférence, y compris les interférences qui peuvent causer un mauvais fonctionnement de l'appareil.*

*En vertu des règlements d'Industrie Canada, cet émetteur de radio ne peut fonctionner en utilisant une antenne d'un type et maximale (ou moins) Gain approuvé pour l'émetteur par Industrie Canada. Pour réduire les interférences radio potentielles aux autres utilisateurs, le type d'antenne et son gain doivent être choisis afin que la puissance isotrope rayonnée équivalente (PIRE) ne est pas plus de ce qui est nécessaire pour une communication réussie.*

We, IEC, declare under our sole responsibility that the device to which this declaration relates: Complies with Part 15 of the FCC Rules. Operation is subject to the following two conditions: (1) this device may not cause harmful interference, and (2) this device must accept any interference received, including interference that may cause undesired operation.

FCC ID: MUH-SKYPORT10

IC: 12547A-SKYPORT10

---

This thermostat has the ability to receive updates to its firmware. Periodically firmware updates are released by the manufacturer to add features and/or performance enhancements. This manual was produced reflecting the most current firmware/feature set at the time of publication, firmware rev. 1.0. Firmware releases after rev. 1.0 may not be adequately depicted in this manual. Please refer to the appropriate website or contact your place of purchase to learn about changes to the thermostat after firmware release 1.0.



Innovation, Science and Economic Development Canada  
ICES-003 Compliance Label: CAN ICES-3 (B)/NMB-3(B)

## Table of Contents

Installation Instructions .....	1
Wire Connections.....	2
Thermostat Backplate .....	3
Connect to Wi-Fi .....	10
Front Panel.....	13
Display.....	14
Basic Operation .....	16
User Setup.....	17
Backlight Operation.....	19
Setpoint Limits .....	20
Installer Setup.....	22
Programming a Daily Schedule .....	29
About Advanced Features & Operation.....	31
Turning On The Time Period Program.....	31
Advanced Setup Table.....	35



### IMPORTANT

Follow Installation Instructions carefully.  
Disconnect Power to the fancoil before removing the old thermostat and installing the new thermostat.

## Glossary of Terms

**Auto-Changeover:** A mode in which the thermostat will turn on the heating or cooling based on room temperature demand.

**Cool Setpoint:** The warmest temperature that the space should rise to before cooling is turned on (without regard to deadband).

**Deadband:** The number of degrees the thermostat will wait, once a setpoint has been reached, before energizing heating or cooling.

**Differential:** The forced temperature difference between the heat setpoint and the cool setpoint.

**Heat Setpoint:** The coolest temperature that the space should drop to before heating is turned on (without regard to deadband).

**Icon:** The word or symbol that appears on the thermostat display.

**Mode:** The current operating condition of the thermostat (i.e. Off, Heat, Cool, Auto, Program On).

**Non-Programmable Thermostat:** A thermostat that does not have the capability of running Time Period Programming.

**Programmable Thermostat:** A thermostat that has the capability of running Time Period Programming.

**Pre-Occupancy Purge:** Fan operation prior to Occupied 1.

**Temperature Swing:** Same as Deadband.

**Time Period Programming:** A program that allows the thermostat to automatically adjust the *heat setpoint* and/or the *cool setpoint* based on the time of the day.

# Installation Instructions

## The Thermostat Backplate

### To remove the thermostat backplate:

Gently separate the display from the base by pulling from the center.

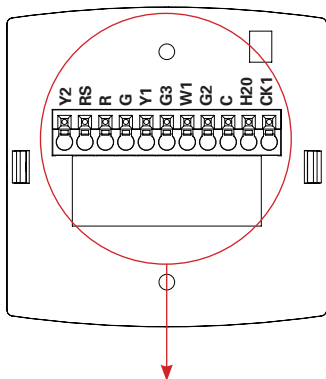

<b>R</b>	24 VAC return	<b>W1</b>	hot water valve (4 pipe) or strip heat (2 pipe)
<b>C</b>	24 VAC common	<b>H20</b>	2 pipe water temp sensor (open = hot, closed = chilled)
<b>G, G2, G3</b>	first/second/third stage fan	<b>CK1</b>	Dry Contact
<b>Y1</b>	chilled water valve (4 pipe) or hot/chilled water valve (2 pipe)	<b>RS</b>	wired remote 10K NTC thermistor
<b>Y2</b>	larger flow 2nd chilled water valve for special fancoil application		

**IMPORTANT: This thermostat requires both R (24 VAC Power) and C (24 VAC Common) wires be connected to the backplate terminals to operate properly.**

## Installation Instructions

### Dip Switch

The Dip Switch has no function in this thermostat.

# Installation Instructions

## Wiring Diagram

### 4-Pipe, Low Voltage Valves, Duct Temperature Sensor & Dry Contact

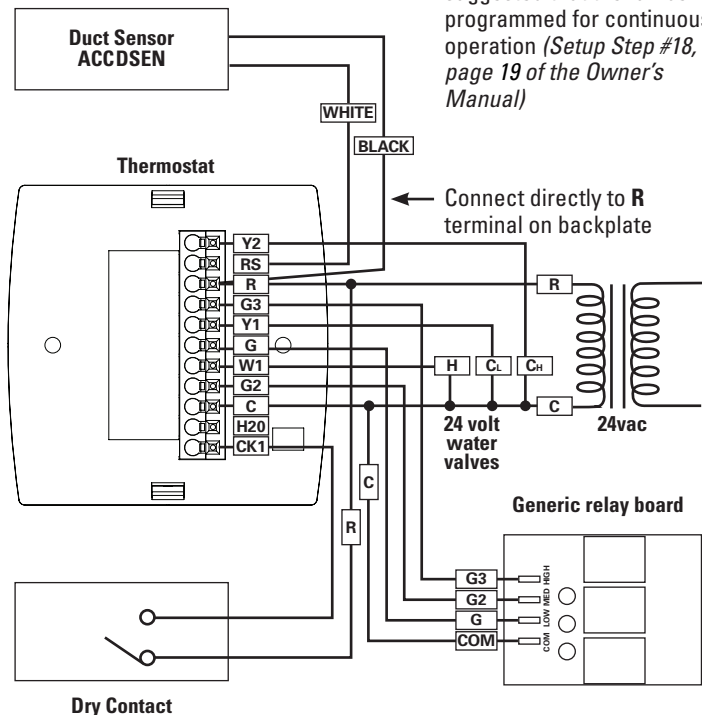

#### IMPORTANT NOTE:

If a duct sensor is connected to this thermostat it is suggested that the fan be programmed for continuous operation (*Setup Step #18, page 19 of the Owner's Manual*)



# Installation Instructions

## Wiring Diagram

### 2-Pipe, Low Voltage Valve, H2O Changeover Sensor

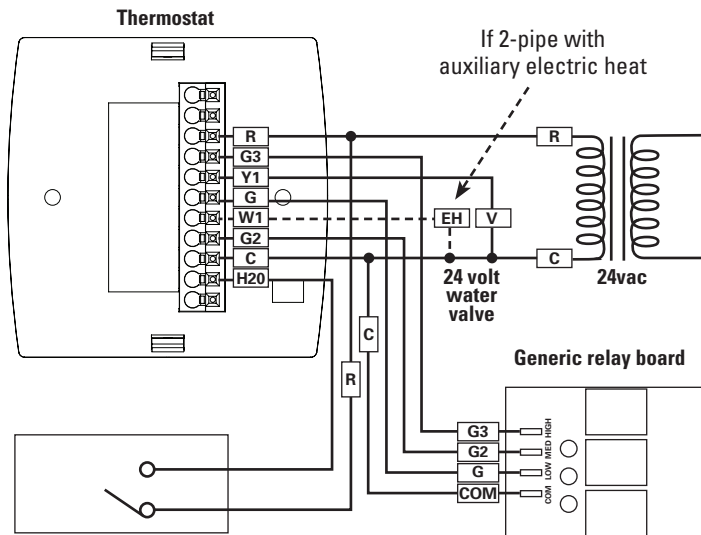

**H<sub>2</sub>O Changeover Sensor**  
(G100-71520306)  
(closes below 60°,  
opens above 75°)

## Connect to Wi-Fi Overview

At minimum the first 3 tasks below must be completed to access your thermostat remotely from a browser. The 4th step is optional (highly recommended) and only is needed to access your thermostat(s) from a mobile device.

### These steps are:

1. Successful connection to a local Wi-Fi Access Point with internet access.
2. Confirm receipt of a Skyport generated verification email (this only occurs once during the Skyport account setup).
3. A 6-digit code obtained from the thermostat is successfully entered into a Skyport account.
4. Successfully download and install the IEC Skyport app on your mobile device(s).

*Your thermostat operates on the 2.4 Ghz, Wi-Fi b/g/n band.*

### Wi-Fi Symbol Legend



When the only the 'dot' of the Wi-Fi symbol appears = not connected to an access point.



When the full Wi-Fi symbol appears = connected to an access point.



When the full Wi-Fi symbol appears and the 'dot' of the symbol is flashing = connected to Skyport.

## Connect to Wi-Fi Overview

### Wi-Fi Setup

*The IEC Configurator App is needed to configure the Wi-Fi Settings of this thermostat*

- **Download the IEC Configurator App** from your mobile device's App Store.



ICON

- **Open the IEC Configurator App**
  - Choose the thermostat by sliding the thermostat pictures at the top of the apps' display to the left until you see a picture of the thermostat.
  - Press and hold the FAN button of the thermostat for approximately 5 seconds to enter Wi-Fi setup screens.
  - Press the cooler button to setup Wi-Fi.
  - Follow the instructions that appear on the IEC Configurator App.

### Connect to Skyport

Although there is more than one way to create a Skyport account, the steps below illustrate account creation from a browser. To create a Skyport account a thermostat must be joined to the account.

If the thermostat is connected to the local Wi-Fi Access Point, but you do not have a Skyport account, you may create an account and join the thermostat to the account by doing the following:

1. Open your browser to: <http://IEC.skyportcloud.com>
2. Select "Create account now"

 **Create Account Now**

3. Follow on screen instructions to create an account and add a thermostat to the Skyport account.

## Connect to Wi-Fi Overview

### Join a Thermostat to Skyport

If the thermostat is connected to the local Wi-Fi access point but not yet joined to an existing Skyport account, you may join the thermostat to the account by doing the following:

1. Log in to your Skyport account.
2. Select the “Location” you want to add a thermostat into.
3. Select the “Thermostat tab”.
4. Select “+ Add thermostat”. A screen will ‘pop-up’ asking for a six digit code.
5. Press the FAN button on the thermostat for 5 seconds.
6. Press the Warmer button on the thermostat.
7. A six digit code will appear on the thermostat’s display.
8. Enter the six digit code into your Skyport account.

### Wi-Fi Status Screens

Press and hold the FAN button on the thermostat for 5 seconds. When “Wi-Fi Setup” appears on the display, press the MODE button. Pressing the up or down button will sequence through the following information:

- AP Name
- AP Signal Strength
- IP Address
- Skyport Status
- API Status

## Front Panel

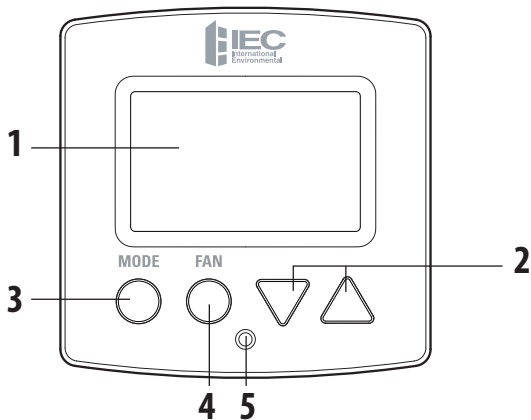

- 1 Backlit Display
- 2 Up/Warmer, Down/Cooler Buttons
- 3 Mode Button
- 4 Fan Button
- 5 Heat or Cool Indicator  
*Heat = Red, Cool = Green*

## Display

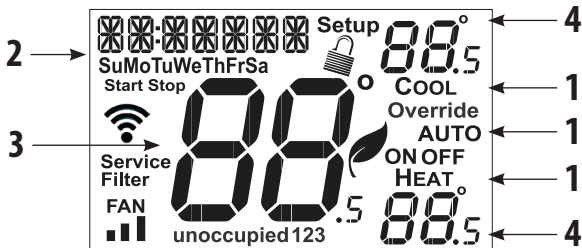

### 1 Mode Indicators

Selects the operational mode of the equipment.

**HEAT** - Indicates the heating mode.

**COOL** - Indicates the cooling mode.

**AUTO** - Indicates the system will automatically changeover between heat and cool modes as the temperature varies.

**OFF** - Indicates heating and cooling are turned off.

### 2 Clock with Day of the Week

Indicates the current time and day. This clock is also used to program the time period schedules.

### 3 Room Temperature Display

Indicates current room temperature.

### 4 Desired Set Temperature

Indicates desired room temperature(s).

## Display

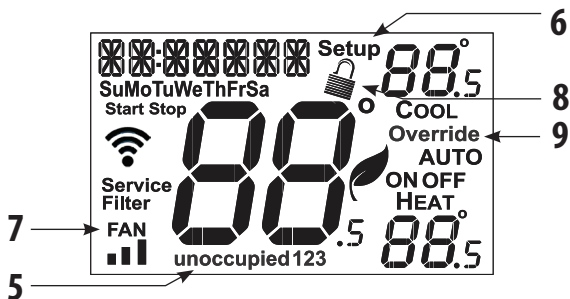

### 5 Occupied and Unoccupied icons

Indicates the part of the time period program.

### 6 Setup icon

Indicates the thermostat is in the setup mode.

### 7 Fan icon

When FAN and any fan speed bar is on, the fan is in manual speed. If the FAN is not on the display, then the FAN is in Auto mode and will run only when necessary to heat or cool.

### 8 Locked icon

Indicates the thermostat's control buttons have been locked.

### 9 Override icon

Indicates OVERRIDE is enabled.

## Basic Operation

### Selecting Your Desired Temperature *(adjusting the setpoints)*

#### Auto-Changeover Mode

Pressing the WARMER or COOLER buttons in Auto mode will adjust both the heat and cool setpoints simultaneously. To adjust the heat and cool setpoints individually, choose HEAT mode to adjust the heat setpoint, and COOL mode to adjust the cool setpoint, then return to AUTO mode.



Adjust the desired set temperature with these buttons

#### Heat or Cool Mode

Pressing the UP or DOWN buttons in Heat or Cool mode will adjust only the heat or cool set temperature.

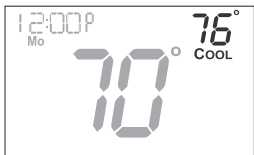

#### Using the FAN Button

Pressing the FAN button will run the fan in low, medium, or high speed continuously.

If the FAN is not on the display, then the fan is in Auto mode and will run only when necessary to heat or cool.

**NOTE:** If the thermostat is placed in the OFF mode, the fan will de-energize.



## Basic Operation

### Using the FAN button for Fan Operation

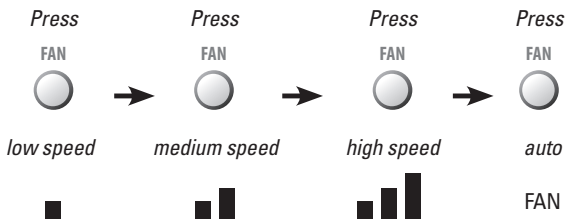

*Note: When the thermostat is placed in OFF with the MODE button the fan will not operate, unless Setup Step #18 is set to ON (page 19).*

### Using the FAN button for OVERRIDE OPERATION

*Note: Override operation may only be used when the thermostat is running a time period schedule/program.*

#### Unoccupied Operation

During programmed, unoccupied periods pressing and holding the FAN button for more than 5 seconds will force the thermostat into occupied 1 settings for 1 to 4 hours (Setup Step #16, page 19). The Override icon will be illuminated during this time.

If you press and hold the FAN button while the thermostat is currently overriding the daily schedule, this will reset the timer, returning the thermostat to the correct time period program for the day.

#### Occupied Operation

Pressing and holding the FAN button for 5 seconds during a programmed Occupied time period will not function as override but will enter the wifi setup section.

## User Setup

Table for button presses that are required for entering various menus

TO ENTER MENUS	BUTTON PRESS
Setup Steps	MODE & FAN for 5 seconds
Time Schedule	MODE & UP for 2 seconds
Emergency Heat	UP & FAN for 2 seconds
Lockout Buttons	MODE, UP & DOWN for 2 seconds
Calibration	MODE & DOWN for 2 seconds, then MODE
Wireless Setup	FAN for 5 seconds unless running time period program

### How to Change Settings in the Setup Screens

*To enter the setup screens, press the MODE button, and simultaneously press FAN button for 5 seconds. Release the buttons when you see "Setup" on the display. Use the WARMER or COOLER buttons to adjust the value of your selection. Press MODE to advance to the next setup step. Press MODE and FAN together again to leave the setup screens.*

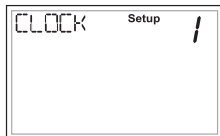
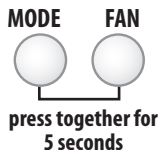

## User Setup

### Setting the Clock and Day (setup steps 1 & 2)

When your thermostat is connected to Skyport Cloud Services, the time and day of the week are controlled by Skyport. There is no local adjustment, Skyport also adjusts the time for Daylight Savings Time as well.

To set the time and day when not connected to Skyport; enter the setup screens by pressing the MODE button and simultaneously pressing the FAN button for 5 seconds.

**Setup step 1** adjusts the clock.

Use the Warmer/Up or Cooler/Down buttons to adjust the time.

Press the MODE button to advance to **step 2**.

Select the day of the week using the Warmer/Up or Cooler/Down buttons.

**Leave the setup screens by again pressing the MODE button and simultaneously pressing the FAN button for 5 seconds.**

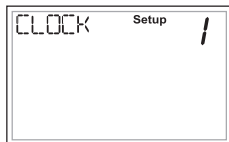

### Show Clock (setup step 3)

This setup step will allow for removal of the clock and day of the week from the display. OFF removes the time and day from the display.

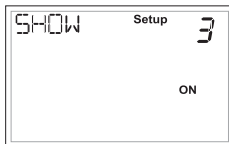

## User Setup: Backlight Operation

### Programmable (setup step 4)

When the very simplest operation is desired, this thermostat may be configured to be non-programmable, with or without Auto-Changeover.

If "NO" is selected, the thermostat will lockout the Program On screen; only the Off, Heat, Cool and Auto screens may be accessed by pressing the **MODE** button.

Select "YES" if you would like your thermostat to be programmable, then the Program mode will be accessible through the use of the **MODE** button.

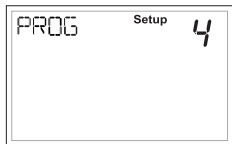

### Backlight (setup steps 5-8)

#### Backlight (setup step 5)

**OFF** - Backlight turns on only with a button press and turns off after 8 seconds.

**ON** - Backlight is on continuously.

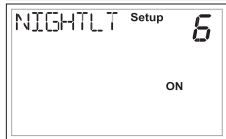
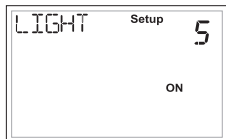

#### Night Dimmer (setup step 6)

Selecting **ON** allows for turning off the backlight of the display during specific times of the day, usually at night.

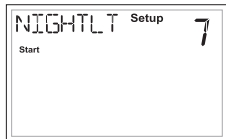

#### Night Dimmer Start Time (setup step 7)

12:00 am to 12:00 am

#### Night Dimmer Stop Time (setup step 8)

12:00 am to 12:00 am



## User Setup: Number of Pipes

### 2 or 4 Pipe System (setup step 9)

Select Fan Coil System type:

- 2 Pipe Fan Coil System, **or**
- 4 pipe Fan Coil System.

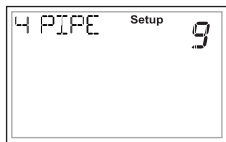

### 2 Pipe System Operation (setup step 10)

Setup Step 10 only appears if Setup Step 9 = 2 pipe

- Heat Only System, **or**
- Cool Only System, **or**
- Heat/Cool Auto Changeover System, **or**
- Heat/Cool Auto Lockout Aux heat when hot H<sub>2</sub>O is available
- Heat/Cool Auto, total electric, no Hot H<sub>2</sub>O

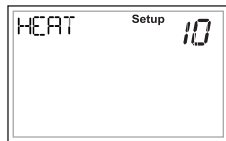

## User Setup: Deadband & Setpoint Limits

### Deadband

The **Deadband** is the number of degrees or minutes that the thermostat waits before it initiates the stages of heating or cooling.

#### 1st Stage Deadband (setup step 11)

Specifies the temperature difference between the room temperature and the desired setpoint before the first stage of heating or cooling is allowed to turn on. (1 - 6 degrees) For example, if the heat setpoint is 68° and the 1st Stage deadband is set to 2 degrees, the room temperature will need to reach **66°** before the heat turns on.



### Minimum Heat/Cool

#### Setpoint Difference (setup step 12)

This feature allows the user to set the minimum gap between Heat and Cool setpoints in AUTO mode. Select from 0 to 6 degrees.



## Installer Setup

### Setpoint Limits (setup step 13)

When this feature is set to ON, the Heat and Cool Setpoints may be restricted to preset levels in Setup Steps 14 and 15.



### Maximum Heat Setpoint (setup step 14)

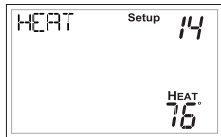

### Minimum Cool Setpoint (setup step 15)

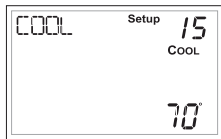

### Lock MODE Buttons

This feature is available when the thermostat is connected to Skyport Cloud Services and may only be accessed through Skyport.

This security feature is not accessible locally at the thermostat.

When this setting is enabled; pressing the MODE button on the thermostat will have no effect.

This feature is often used in conjunction with setpoint limits.

## Installer Setup

### Maximum Override Time (setup step 16)

This feature limits the maximum override time when using the OVERRIDE button 1 - 4 hours.

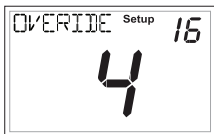

### Fahrenheit or Celsius (setup step 17)

This feature allows the thermostat to display temperature in Fahrenheit or Celsius.

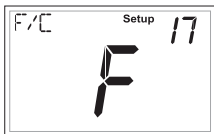

### Fan Auto Operation (setup step 18)

ON = Continuous low speed fan

OFF = Only energize with a heating or cooling cycle

This step is useful when using a duct sensor to keep airflow for the sensor.

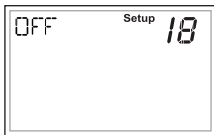

### Fan Relay Type (setup step 19)

- Normal = Conventional 3 speed fan coil system
- Special = Carrier or IEC Fan Coil using a 33ZCRLYBRD Relay Board

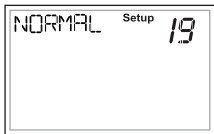

### Wired Sensor Type (setup step 20)

RETURN, OUTDOOR, SUPPLY = the sensor temperature is reported to Skyport to monitor only

REMOTE = the sensor can be used for temperature control.





## Installer Setup

### Control to Sensor (setup step 21)

Select LOCAL to control to the temperature sensor inside the thermostat.

Select REMOTE to control to a temperature sensor connected to the RS & R terminals of the thermostat backplate.

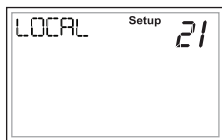

### Pre-Occupancy Fan Purge (setup step 22)

When this feature is activated, the fan will turn on during an unoccupied period at a preset amount of time prior to Occupied 1. This pre-occupancy fan purge timer may be set from zero to three hours, in 15 minute increments. Zero (0) means this feature is turned off.

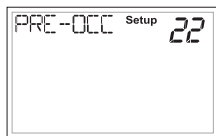

## Installer Setup

### Hot Water Valve Type (setup step 23)

NORMAL CLOSED = Usual setting, hot water valve does not allow water flow when unpowered

NORMAL OPEN = Hot water valve allows water flow when unpowered

Options, NORMALLY OPEN and NORMALLY CLOSED, default = NORMALLY CLOSED.

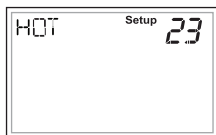

### Chilled Water Valve Type (setup step 24)

NORMAL CLOSED = Usual setting, chilled water valve does not allow water flow when unpowered.

NORMAL OPEN = Chilled water valve allows waterflow when unpowered.

Options, NORMALLY OPEN and NORMALLY CLOSED, default = NORMALLY CLOSED.

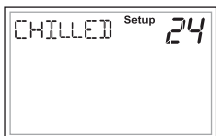

*These steps configure the type of water valve(s) connected to the thermostat. A normally closed valve allows no water flow when no power is applied to it. A normally open valve allows water flow when no power is applied to it. Some 4 pipe fancoils use a normally closed chilled water valve with a normally open hot water valve. If you have a two pipe fancoil, the setting in Setup Step 24 for CHILLED WATER VALVE will apply to the single valve in use.*

## Installer Setup

### Dry Contact Operation

#### Dry Contact Polarity (setup step 25)

**Open (Normally Open)** - The dry contact is open until the connected device closes the circuit.



**Closed (Normally Closed)** - The dry contact is closed until the connected device opens the circuit.

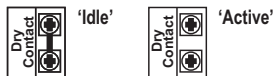

#### Dry Contact Use (setup step 26)

**Condensate Pan** - If selected when the Dry Contact is active, the thermostat will lockout compressor terminal(s) and "CONDENSATE PAN" will appear on the display.

**Holiday** - If Holiday is selected when the dry contact is active, the thermostat will be forced into HOLIDAY/ Unoccupied settings.

**Occupied** - If Occupied is selected when the dry contact is active, the thermostat will be forced into occupied settings.

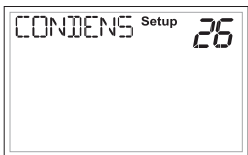

## Installer Setup

### Skyport Cloud Services (setup step 27)

If set to ON, the thermostat may communicate and receive data from the Skyport Cloud Services.



### Local API (setup step 28)

Turning on the local API allows 3rd party software to interface with the thermostat such as a home automation system.

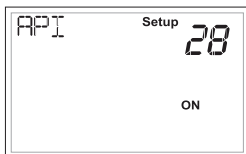

### Time API (setup step 29)

Only appears when prior step for Local API is set to ON. This step allows the internal clock to be altered using the API.

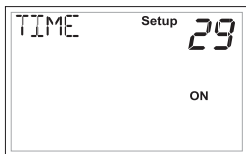

**NOTE:** It is permissible to enable both Skyport and the local API at the same time.

## Installer Setup

### Locking/Unlocking the Keypad

To prevent unauthorized use of the thermostat, the front panel buttons may be disabled. To disable, or 'lock' the keypad, press and hold the MODE button. While holding the MODE button, press the WARMER and COOLER buttons together, for two seconds.

The  icon will appear on the display, then release the buttons.

Press all three buttons in the order outlined for keypad lockout

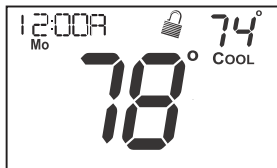

MODE



To **unlock** the keypad, press and hold the MODE button. While holding the MODE button, press the WARMER and COOLER buttons together, for two seconds.

The  icon will disappear from the display, then release the buttons.

## Programming a Daily Schedule

### Programming a Daily Schedule

To enter Time Period Programming screens, Press and hold MODE and UP until the scrolling prompt appears.



**Select the number of Occupied time periods** – Press the Warmer or Cooler buttons to choose the maximum number (up to 3 maximum) of Occupied time periods in a day.

**Select the Mode for the Occupied period** – Press the Warmer or Cooler buttons to choose the mode for the occupied period. The choices are: Off, Heat only, Cool only and AUTO changeover.

**Adjust the Occupied Cool Setpoint** – Press the Warmer or Cooler buttons to adjust the Cooling setpoint for comfort.

**Adjust the Occupied Heat Setpoint** – Press the Warmer or Cooler buttons to adjust the Heating setpoint for comfort.

**Set the Unoccupied Mode** – Press the Warmer or Cooler buttons to choose the mode for the Unoccupied period. The thermostat is in Unoccupied when the Time Period Schedule is running and there is not an active Occupied period. The choices are: Off, Heat only, Cool only and AUTO changeover.

**Adjust the Unoccupied Cool Setpoint** – Press the Warmer or Cooler buttons to adjust the Cooling setpoint for times when the thermostat is in Unoccupied.

*Continued*

## Programming a Daily Schedule

*Continued*

**Adjust the Unoccupied Heat Setpoint** – Press the Warmer or Cooler button to adjust the Heating setpoint for times when the thermostat is in Unoccupied.

***The following steps determine when the Occupied period(s) will be active.***

**Enable Occupied 1** – Press the Warmer or Cooler button to enable (On) or to disable (Off) Occupied 1 on Monday.

**Adjust the Start Time for Occupied 1** – Press the Warmer or Cooler button to adjust the start time for Occupied 1 on Monday.

**Adjust the Stop Time for Occupied 1** – Press the Warmer or Cooler button to adjust the stop time for Occupied 1 on Monday.

Upon pressing MODE after the above step; you will be prompted to Save and Exit or Copy this Occupied schedule to another day.

**To save and exit** – Press the MODE and WARMER button.

**To Copy Monday's settings/schedule to Tuesday** – Press Up and then MODE. Press MODE again to copy the Monday Settings/schedule to subsequent days.

**To Program Another Day** – Press MODE and then press the WARMER/COOLER button to select the day to program. Repeat the above steps for each day you would like to program.

***Press and hold the MODE/WARMER Buttons to exit Time Period Programming at any time.***

## About Advanced Features & Operation

**DEADBAND OPERATION** - Controls one Heat and one Cool stage with a three speed fan (see below).

The **low speed fan** for heat or cool is turned on when: The temperature spread from the setpoint is equal to or greater than: *the setpoint plus the 1st stage dead-band (Setup Step 11, page 17)*. This 1st stage deadband is adjustable from 1-6 degrees and the default is two degrees.

The **medium speed fan** for heat or cool is turned on when: The temperature spread from the setpoint is equal to or greater than: *the setpoint plus the 1st stage deadband (Setup Step 11, page 17), plus the 2nd stage dead-band*. This 2nd stage deadband is fixed at one degree and is not adjustable.

The **high speed fan** for heat or cool is turned on when: The temperature spread from the setpoint is equal to or greater than: *the setpoint plus the 1st stage deadband (Setup Step 11, page 17), plus the 2nd stage deadband, plus the 3rd stage deadband*. This 3rd stage deadband is fixed at one degree and is not adjustable.

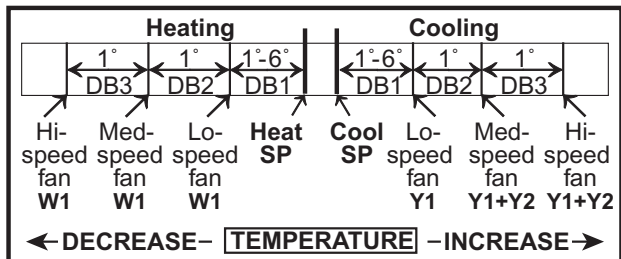



## About Advanced Features & Operation

### Calibration

Under normal circumstances it will not be necessary to adjust the calibration of the temperature sensor. If calibration is required, please contact a trained HVAC technician to correctly perform the following procedure.

- 1 **MODE** Place the thermostat in the OFF mode.

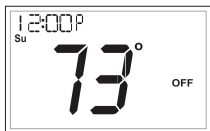

- 2 **MODE** Press and hold the MODE button. While holding the **MODE** button, press and hold the **DOWN** button for 5 seconds.



All icons will appear on the display.

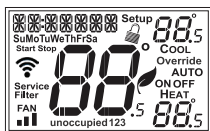

- 3 **MODE** Press the **MODE** button once. The thermostat temperature will be displayed and may be calibrated using the **UP** or **DOWN** buttons. The calibrated offset from the "raw" temperature reading is displayed in the lower right corner.



Additionally, on this screen you may view the Software Version in the upper left corner.

- 4 **MODE** After calibration is complete, press the **MODE** button **once** to save your changes and return to normal operation.

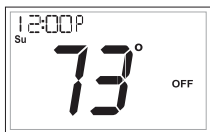

## About Advanced Features & Operation



### Factory Defaults

If, for any reason, you desire to return all the stored settings back to the factory default settings, follow the instructions below.

***WARNING: This will reset all Time Period and Advanced Programming to the default settings. Any information entered prior to this reset will be permanently lost.***

- MODE**  
 Place the thermostat in the OFF mode.

---

- MODE**  
  
 Press and hold the MODE button. While holding the MODE button, press and hold the DOWN button for 5 seconds. All icons will appear on the display.

---

- 3**  
**OVERVERRIDE**  

**A.** After all of the icons appear, release the MODE and DOWN buttons.  
**B.** Press and hold the FAN button for 2 seconds. Fd (Factory default settings) and ALL will appear on the display.

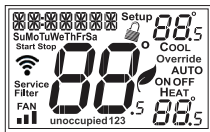
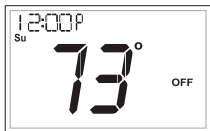

(Continued)

## About Advanced Features & Operation

(Continued)

You now have the option of restoring the factory settings to just Wi-Fi (**Wi-Fi**), or just the thermostat (**STAT**), or both the thermostat and Wi-Fi (**ALL**).

**C.** Select one of the above options using the Up or Down buttons.

**D.** Press FAN for 2 seconds to restore the factory settings.



FAN



After factory settings are restored, the thermostat display will return to the "all icon" screen.

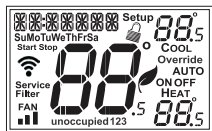

4



To return to normal operation;  
Press the **MODE** button twice.

# Advanced Setup Table

FD = Factory Default Setting

Step#	Description	Pg#	Range	FD
1	CLOCK		12A - 12A	12P
2	WEEKDAY		Monday - Sunday	Monday
3	SHOW CLOCK		On, Off	On
4	PROG		On, Off	On
5	BACKLIGHT		On, Off	Off
6	NIGHTLT		On, Off	Off
7	NIGHTLT START		12A - 12A	8:00P
8	NIGHTLT STOP		12A - 12A	6:00A
9	NUMBER OF WATER PIPES		4 PIPE, 2 PIPE	4 PIPE
10	2 PIPE SUBMODE (only if prior step = 2)		Heat Only, Cool Only Auto Change, Total Elec Auto Change, Aux Heat Auto Change	Auto Change
11	1ST STAGE DEADBAND		1 - 6 degrees	2
12	MINIMUM HEAT/COOL SPREAD (unless 2 pipe single mode)		0 - 6 degrees	2
13	SETPOINT LIMITS		On, Off	Off
14	MAX HEAT SETPOINT		35 - 99 degrees	82
15	MIN COOL SETPOINT		35 - 99 degrees	66
16	MAX OVRRIIDE TIME IN HOURS		0 - 4 hrs	4
17	DISPLAY F/C		F, C	F
18	CONTINUOUS FAN, ON (low) or OFF (auto)		On, Off	Off
19	CARRIER FAN TYPE, ON (carrier) or OFF		On, Off	Off
20	WIRED SENSOR TYPE		control, monitor	control
21	CONTROL TO TEMP SOURCE		thermostat, sensor	thermostat
22	PRE-OCC FAN PURGE TIME		off - 3 hrs	off
23	HOT WATER VALVE TYPE		n.o / n.c.	n.c.
24	CHILLED WATER VALVE TYPE		n.o / n.c.	n.c.
25	DRY CONTACT POLARTY		n.o / n.c.	n.c.
26	DRY CONTACT USE		occupied, condensate, fdd, holiday	condensate
27	SKYPORT		On, Off	On
28	API		On, Off	Off
29	TIME API		On, Off	Off

## TO ENTER MENUS..... BUTTON PRESS

Setup Steps ..... MODE & OVERRIDE for 5 sec.

Time Schedule ..... MODE & UP for 2 seconds

Emergency Heat ..... UP & OVERRIDE for 2 seconds

## TO ENTER MENUS.....BUTTON PRESS

Lockout Buttons.....MODE, UP & DOWN for 2 sec.

Calibration.....MODE & DOWN for 2 sec., then MODE

Wireless Setup .....OVERRIDE for 5 Seconds

# Warranty

One-Year Warranty - This Product is warranted to be free from defects in material and workmanship. If it appears within one year from the date of original installation, whether or not actual use begins on that date, that the product does not meet this warranty, a new or remanufactured part, at the manufacturer's sole option to replace any defective part, will be provided without charge for the part itself provided the defective part is returned to the distributor through a qualified servicing dealer.

THIS WARRANTY DOES NOT INCLUDE LABOR OR OTHER COSTS incurred for diagnosing, repairing, removing, installing, shipping, servicing or handling of either defective parts or replacement parts. Such costs may be covered by a separate warranty provided by the installer.

THIS WARRANTY APPLIES ONLY TO PRODUCTS IN THEIR ORIGINAL INSTALLATION LOCATION AND BECOMES VOID UPON REINSTALLATION.

LIMITATIONS OF WARRANTIES – ALL IMPLIED WARRANTIES (INCLUDING IMPLIED WARRANTIES OF FITNESS FOR A PARTICULAR PURPOSE AND MERCHANTABILITY) ARE HEREBY LIMITED IN DURATION TO THE PERIOD FOR WHICH THE LIMITED WARRANTY IS GIVEN. SOME STATES DO NOT ALLOW LIMITATIONS ON HOW LONG AN IMPLIED WARRANTY LASTS, SO THE ABOVE MAY NOT APPLY TO YOU. THE EXPRESSED WARRANTIES MADE IN THIS WARRANTY ARE EXCLUSIVE AND MAY NOT BE ALTERED, ENLARGED, OR CHANGED BY ANY DISTRIBUTOR, DEALER, OR OTHER PERSON WHATSOEVER.

ALL WORK UNDER THE TERMS OF THIS WARRANTY SHALL BE PERFORMED DURING NORMAL WORKING HOURS. ALL REPLACEMENT PARTS, WHETHER NEW OR REMANUFACTURED, ASSUME AS THEIR WARRANTY PERIOD ONLY THE REMAINING TIME PERIOD OF THIS WARRANTY. THE

MANUFACTURER WILL NOT BE RESPONSIBLE FOR:

1. Normal maintenance as outlined in the installation and servicing instructions or owner's manual, including filter cleaning and/or replacement and lubrication.
2. Damage or repairs required as a consequence of faulty installation, misapplication, abuse, improper servicing, unauthorized alteration or improper operation.
3. Failure to start due to voltage conditions, blown fuses, open circuit breakers or other damages due to the inadequacy or interruption of electrical service.
4. Damage as a result of floods, winds, fires, lightning, accidents, corrosive environments or other conditions beyond the control of the Manufacturer.
5. Parts not supplied or designated by the Manufacturer, or damages resulting from their use.
6. Manufacturer products installed outside the continental U.S.A., Alaska, Hawaii, and Canada.
7. Electricity or fuel costs or increases in electricity or fuel costs for any reason whatsoever including additional or unusual use of supplemental electric heat.
8. ANY SPECIAL INDIRECT OR CONSEQUENTIAL PROPERTY OR COMMERCIAL DAMAGE OF ANY NATURE WHATSOEVER. Some states do not allow the exclusion of incidental or consequential damages, so the above may not apply to you.

This warranty gives you specific legal rights and you may also have other rights which may vary from state to state.

