

## TEST REPORT

**Report Number: 3047393-43-01-1**

**Project Number: 3047393**

**December 16, 2003**

**Evaluation of the  
SX5P CDMA Desk Phone  
Model Number: 1D02A035**

**FCC ID: MTF050398**

**to**

**FCC Part 15  
FCC Part 22 Subpart H  
FCC Part 24 Subpart E**

Test Performed by:  
Intertek  
1950 Evergreen Blvd. Suite 100  
Duluth, GA 30096

Test Authorized by:  
Telular Corporation  
580 Old Willets Path  
Hauppauge, NY 11788

Prepared by:



Matthew Van Steen, Project Engineer - EMC

Date: 12/17/2003

Reviewed by:



David J. Schramm, Team Leader - EMC

Date: 12/17/2003

*All services undertaken are subject to the following general policy: Reports are submitted for exclusive use of the client to whom they are addressed. Their significance is subject to the adequacy and representative character of the samples and to the comprehensiveness of the tests, examinations or surveys made. This report shall not be reproduced except in full, without written consent of Intertek Testing Services NA Inc. This report must not be used to claim product endorsement by A2LA, NIST nor any other agency of the U.S. Government.*

**TABLE OF CONTENTS**

**EXECUTIVE SUMMARY ..... 4**

**1 JOB DESCRIPTION ..... 5**

1.1 CLIENT INFORMATION ..... 5

1.2 TEST PLAN REFERENCE: ..... 5

1.3 EQUIPMENT UNDER TEST (EUT) ..... 6

    1.3.1 System Support Equipment..... 7

    1.3.2 Cables associated with EUT ..... 7

    1.3.3 System Block Diagram ..... 7

    1.3.4 Justification..... 8

    1.3.5 Mode(s) of operation..... 8

1.4 MODIFICATIONS REQUIRED FOR COMPLIANCE..... 8

1.5 RELATED SUBMITTAL(S) GRANTS ..... 8

**2 TEST FACILITY ..... 9**

**3 CONDUCTED RF POWER ..... 10**

3.1 TEST PROCEDURE..... 10

3.2 TEST EQUIPMENT ..... 10

3.3 TEST RESULTS ..... 10

**4 RADIATED RF POWER..... 11**

4.1 TEST PROCEDURE..... 11

4.2 TEST EQUIPMENT ..... 11

4.3 TEST RESULTS ..... 12

**5 EMISSION LIMITATIONS, OCCUPIED BANDWIDTH ..... 13**

5.1 TEST PROCEDURE..... 13

5.2 TEST EQUIPMENT ..... 13

5.3 TEST RESULTS ..... 13

**6 OUT OF BAND EMISSION AT ANTENNA TERMINALS..... 17**

6.1 TEST PROCEDURE..... 17

6.2 TEST EQUIPMENT ..... 17

6.3 TEST RESULTS ..... 17

**7 FIELD STRENGTH OF SPURIOUS RADIATION ..... 23**

7.1 TEST PROCEDURE..... 23

7.2 TEST EQUIPMENT ..... 23

7.3 TEST RESULTS ..... 24

**8 POWER LINE CONDUCTED EMISSIONS..... 34**

8.1 TEST PROCEDURE..... 34

8.2 TEST EQUIPMENT ..... 34

8.3 TEST RESULTS ..... 35

**9 FREQUENCY STABILITY VS TEMPERATURE ..... 36**

9.1 TEST PROCEDURE..... 36

9.2 TEST EQUIPMENT ..... 36

9.3 TEST RESULTS ..... 37

**10 RECEIVER SPURIOUS EMISSIONS ..... 38**

10.1 TEST LIMITS ..... 38

10.2 TEST EQUIPMENT ..... 38

10.3 TEST PROCEDURE..... 39

10.4 TEST RESULTS ..... 40

## Executive Summary

Testing performed for: Telular Corporation

Equipment Under Test: 1D02A035, SX5P CDMA Desk Phone

FCC RULE	IC RULE	DESCRIPTION OF TEST	RESULT	PAGE
§2.1046	RSS-129 §9 RSS-133 §6.2	RF Power Output	Passed	10
§22.913, §24.232	RSS-129 §9 RSS-133 §6.2	ERP, EIRP	Passed	12
§2.1049 §22.917(b)(d)	RSS-129 §9	Emission Limitation, Occupied Bandwidth	Passed	13
§2.1051 §22.917(e) §22.917(f) §24.238(a)	RSS-129 §8 RSS-133 §6.3	Out of Band Emissions at Antenna Terminals  Mobile Emissions In Base Frequency Range	Passed	17
§2.1053	RSS-129 §8 RSS-133 §6.3	Field Strength of Spurious Radiation	Passed	23
§15.107, §15.207	IC ES-003	Power Line Conducted Emissions	Passed	34
§2.1055, §22.355, §24.235	RSS-129 §7, § 9 RSS-133 §7	Frequency Stability	Passed	36
§2.1091, §2.1093	RSS-129 §11, RSS-133 §8	RF Exposure	--	See Note <sup>1</sup>
§15.109	IC ES-003  RSS-129 §10, RSS-133 §9	Receiver Spurious Emission	Passed	33

---

<sup>1</sup> The MPE is addressed in a separate document.

## 1 JOB DESCRIPTION

### 1.1 Client information

The SX5P CDMA Desk Phone has been tested at the request of

Company: Telular Corporation  
580 Old Willets Path  
Hauppauge, NY 11788

Name of contact: Matthew McKiernan  
Telephone: (631) 232-6070  
Fax: (631) 232 6082

### 1.2 Test plan reference:

Tests were performed to the following standards:

- FCC Part 15
- FCC Part 22 Subpart H rules for an intentional radiator
- FCC Part 24 Subpart E rules for an intentional radiator

The test procedures described in this test report and ANSI C63.4: 1992 were employed.

### 1.3 Equipment Under Test (EUT)

Product	SX5P CDMA Desk Phone
EUT Model Number	1D02A035
EUT Serial Number	XA4LRS1383R
Whether quantity (>1) production is planned	Quantity production is planned.
Cellular Phone standards	CDMA 800 and CDMA 1900
Type(s) of Emission	1M25F9W
RF Output Power	See Section 3.3
Frequency Range	824 – 849                      CDMA 800
	1850 – 1910                    CDMA 1900
Antenna	Removable antenna with TNC type connector
Detachable Antenna?	Yes

EUT receive date:                      November 25, 2003  
 EUT receive condition:                The EUT was received in good condition with no apparent damage.  
 Test start date:                         November 25, 2003  
 Test completion date:                 December 16, 2003

The test results in this report pertain only to the item tested.

*Table 1: Details of Equipment Under Test*

Description	Model Number	Serial Number
Dual Band CDMA Cellular Phone	1D02A035D	XA4LRS1383R
AC/DC Power Supply	TMG-0716	0716018370

The EUT is a wireless CDMA desk phone that operates in the CDMA 800 and CDMA 1900 bands.

**1.3.1 System Support Equipment**

There was no support equipment required to operate the EUT other than the base station simulator, which is listed as test equipment.

**1.3.2 Cables associated with EUT**

Table 1-2 contains the details of the cables associated with the EUT.

*Table 1-2: Interconnecting cables between modules of EUT*

Cables					
Description	Length	Shielding	Ferrites	Connection	
				From	To
AC Power Supply Cable	2 m	No	No	AC Mains	EUT

**1.3.3 System Block Diagram**

The diagram shown below details the interconnection of the EUT and its accessories during FCC Part 15 testing. For specific layout, refer to the test configuration photograph in the relevant section of this report.

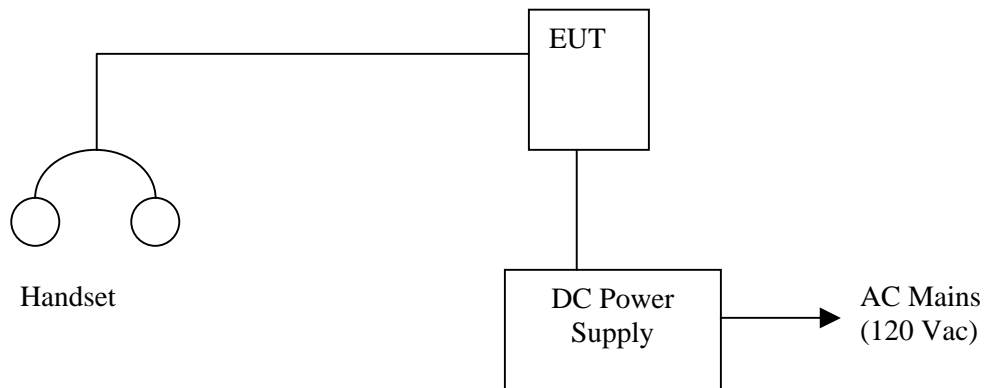

## **1.3.4 Justification**

The EUT was operated in the stand-alone configuration.

## **1.3.5 Mode(s) of operation**

The EUT was powered from 120V AC, supplied by the AC mains of the test facility, for all testing. Battery power is for back-up purposes only. The EUT was set to the CDMA 800 or CDMA 1900 mode during testing.

## **1.4 Modifications required for compliance**

No modifications were implemented by Intertek Testing Services.

## **1.5 Related Submittal(s) Grants**

None



## 2 TEST FACILITY

The Intertek test site is located at 1950 Evergreen Blvd, Suite 100, Duluth, GA 30093. The radiated emission test site is a 10-meter semi-anechoic chamber. The chamber meets the characteristics of C63.4: 2001. For measurements, a remotely controlled flush-mount metal-top turntable is used to rotate the EUT a full 360 degrees. A remote controlled non-conductive antenna mast is used to scan the antenna height from one to four meters.

### 3 CONDUCTED RF POWER

FCC §2.1046

#### 3.1 Test Procedure

The transmitter output was connected to a calibrated coaxial attenuator, the other end of which was connected to a power meter. Transmitter output was read off the power meter in dBm. The power output at the transmitter antenna port was determined by adding the value of the attenuator to the power meter reading.

Tests were performed at three frequencies (low, middle, and high channels) and on the highest power levels that can be setup on the transmitters.

#### 3.2 Test Equipment

Description	Manufacturer	Model Number	Serial Number
Base Station Simulator	Rhode & Schwarz	CMU 200	837198/089
Temperature Chamber	Thermotron	SM-8C	32692
PMA	Solar Light Co.	PMA 2100	5462
Temperature Probe	Solar Light Co.	PMA 2170	6613

#### 3.3 Test Results

*Table 3-1 Conducted RF Power*

EUT Mode	Frequency MHz	Channel	Measured Power dBm		
			+60°C	+20°C	-30°C
CDMA 800	824.70	1013	25.3	25.5	25.9
	836.52	384	25.7	26.2	26.0
	848.30	777	25.3	25.5	26.1
CDMA 1900	1851.25	25	25.5	25.6	25.4
	1880.00	600	24.7	24.7	24.9
	1908.75	1175	23.4	24.0	24.2

#### 4 RADIATED RF POWER

FCC §22.913: The effective radiated power (ERP) of mobile transmitters and auxiliary test transmitters must not exceed 7 Watts.

FCC §24.232: The equivalent Isotropic Radiated Power (EIRP) must not exceed 2 Watts.

##### 4.1 Test Procedure

The EUT was placed on a non-conductive turntable with the earpiece attached. The earpiece was extended vertically above the EUT using a non-conductive support. The radiated emission at the fundamental frequency was measured at 3m with a test antenna and EMI receiver.

During the measurement of the EUT, the receiver resolution bandwidth was set to 3 MHz and the average bandwidth was set to 10 kHz. These settings matched the power readings of a power meter with a thermocouple power sensor. The highest emission was recorded with the rotation of the turntable and the raising and lowering of the test antenna. The receiver reading was recorded and the field strength (E in dBμV/m) was calculated.

ERP in frequency band 824-849 MHz, and EIRP in frequency band 1851.25-1910 MHz were measured using a substitution method. The EUT was replaced by half-wave dipole (824-849 MHz) or horn antenna (1851.25-1910 MHz) connected to a signal generator, which was set to approximately -10 dBm. The spectrum analyzer reading was recorded and ERP/EIRP was calculated as follows:

$$\begin{aligned} \text{ERP} &= E_1 - E_2 + V_g \\ \text{EIRP} &= E_1 - E_2 + V_g + G \end{aligned}$$

where,

- $E_1$  is the receiver reading in dBμV/m when measuring the field strength of the EUT
- $E_2$  is the receiver reading in dBμV/m when measured field strength from the generator
- $V_g$  is the generator output in dBm
- G is the gain of the transmitting antenna in dBi.

##### 4.2 Test Equipment

Description	Manufacturer	Model Number	Serial Number
Signal Generator	Fluke	6061	6061014
Dipole Antenna	CDI	A100	423
Horn Antenna	EMCO	3115	9208-3919
Receive Antenna	Chase	CBL6112B	2622
EMI Receiver	HP	8546A	3410A00173
EMI Receiver, Preselector section	HP	85460A	3348A00203

**4.3 Test Results**

*Table 4-1 Radiated RF Power*

Antenna Polarity (V/H)	Frequency MHz	Channel	EUT Reading dBm <b>S1</b>	Reading from Subs Antenna <b>S2</b>	Sig Gen Output dBm <b>SG</b>	Path Loss dB <b>SG-S2</b>	Antenna Gain dBi	Radiated Power dBm ERP
------------------------	---------------	---------	------------------------------	--	---------------------------------	------------------------------	------------------	------------------------

**CDMA 800**

V	824.700	1013	-10.7	-34.6	-0.7	33.9	NA	23.2
H	824.700	1013	-19.5	-31.9	-0.7	31.2	NA	11.7
V	836.520	384	-9.9	-34.7	-0.7	34.1	NA	24.2
H	836.520	384	-17.8	-31.8	-0.7	31.1	NA	13.3
V	848.300	777	-9.4	-33.9	-0.7	33.1	NA	23.7
H	848.300	777	-17.3	-31.8	-0.7	31.1	NA	13.8

Antenna Polarity (V/H)	Frequency MHz	Channel	EUT Reading dBm <b>S1</b>	Reading from Subs Antenna <b>S2</b>	Sig Gen Level dBm <b>SG</b>	Path Loss dB <b>SG-S2</b>	Antenna Gain dBi Horn only	Radiated Power dBm EIRP
------------------------	---------------	---------	------------------------------	--	--------------------------------	------------------------------	-------------------------------	-------------------------

**CDMA 1900**

V	1851.250	25	-17.3	-36.6	-2.1	34.5	7.2	24.4
H	1851.250	25	-26.0	-35.1	-2.1	32.9	7.1	14.0
V	1880.000	600	-16.2	-37.7	-2.2	35.5	7.3	26.6
H	1880.000	600	-22.5	-35.9	-2.2	33.7	7.1	18.3
V	1908.750	1175	-17.7	-38.2	-2.3	36.0	7.3	25.6
H	1908.750	1175	-23.4	-36.7	-2.3	34.5	7.2	18.2

**5 EMISSION LIMITATIONS, OCCUPIED BANDWIDTH**

CFR 47 §2.1049

**5.1 Test Procedure**

The 99% Bandwidth function of the spectrum analyzer was used to measure the bandwidth.

**5.2 Test Equipment**

Description	Manufacturer	Model Number	Serial Number
Attenuator	Weinschel	2	BK7890
Attenuator	Weinschel	2	BK2313
Spectrum Analyzer	HP	8595E	3249A00243

**5.3 Test Results**

*Table 5-1: Occupied bandwidth measurements*

Mode	Channel	Resolution Bandwidth	Video Bandwidth	Sweep time	Measured Bandwidth MHz
CDMA 800	1013	30 kHz	300 Hz	1.25 s	1.275
CDMA 800	384	30 kHz	300 Hz	1.25 s	1.275
CDMA 800	777	30 kHz	300 Hz	1.25 s	1.284
CDMA 1900	25	30 kHz	300 Hz	1.25 s	1.266
CDMA 1900	600	30 kHz	300 Hz	1.25 s	1.275
CDMA 1900	1175	30 kHz	300 Hz	1.25 s	1.266

Figure 5-1: Occupied Bandwidth – CDMA 800 Channel 1013

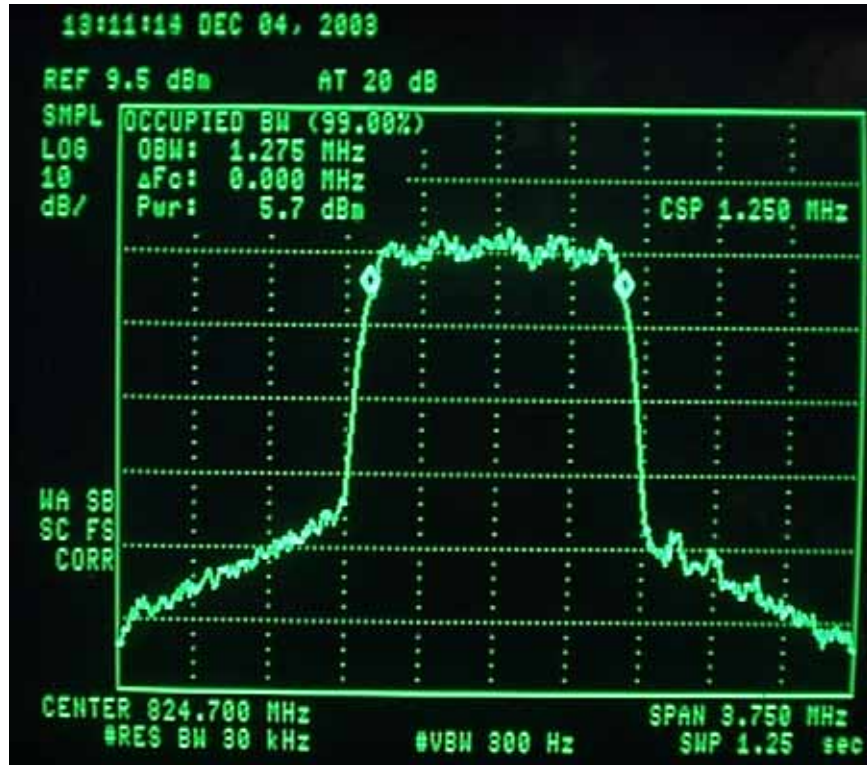

Figure 5-2: Occupied Bandwidth – CDMA 800 Channel 384

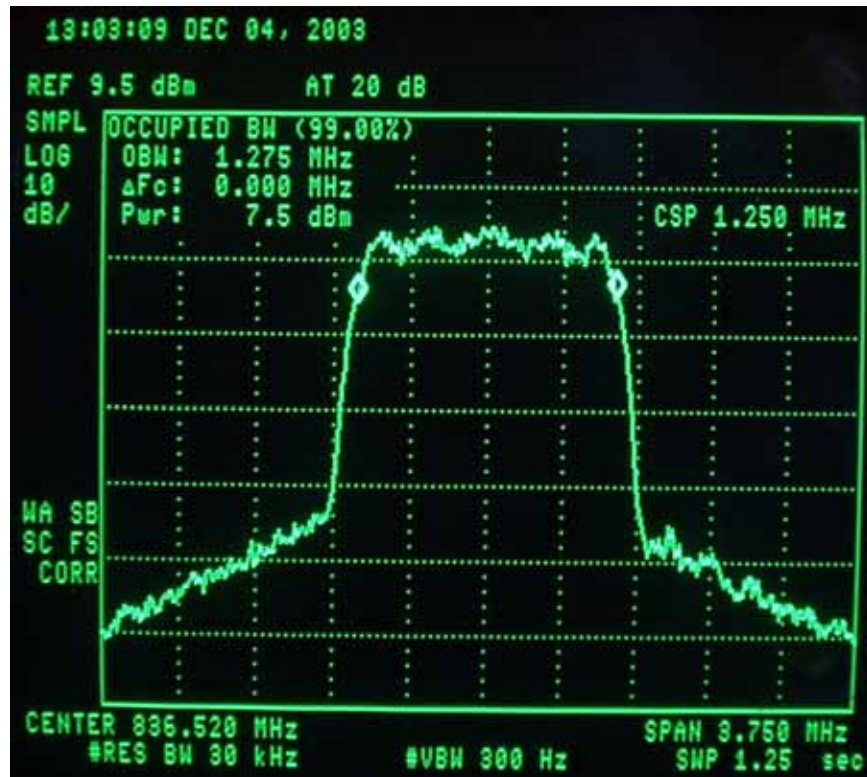

Figure 5-3: Occupied Bandwidth – CDMA 800 Channel 777

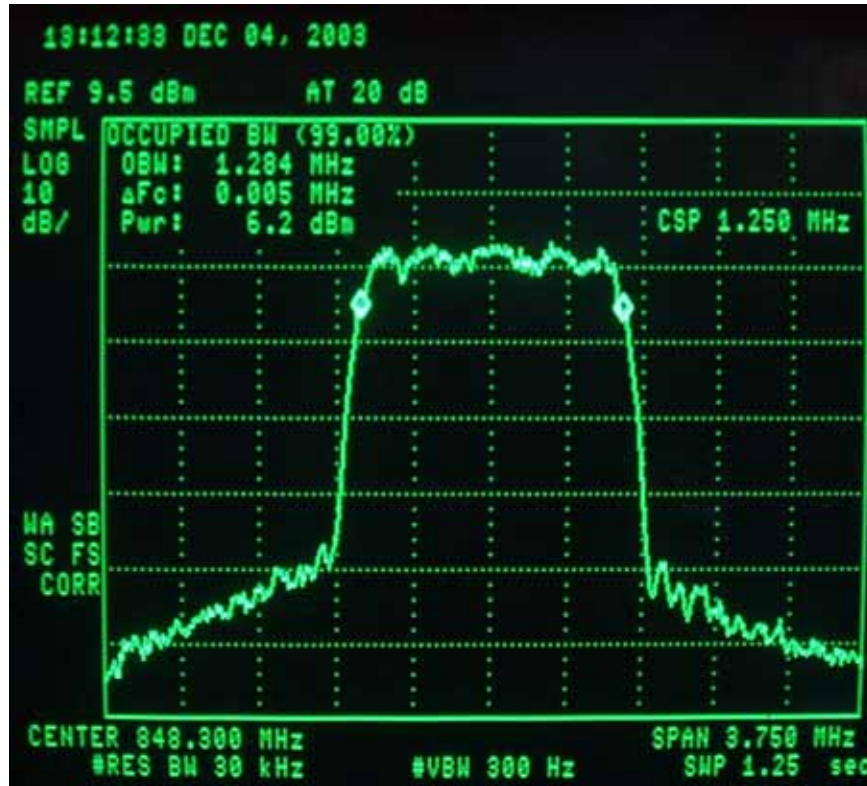

Figure 5-4: Occupied Bandwidth – CDMA 1900 Channel 25

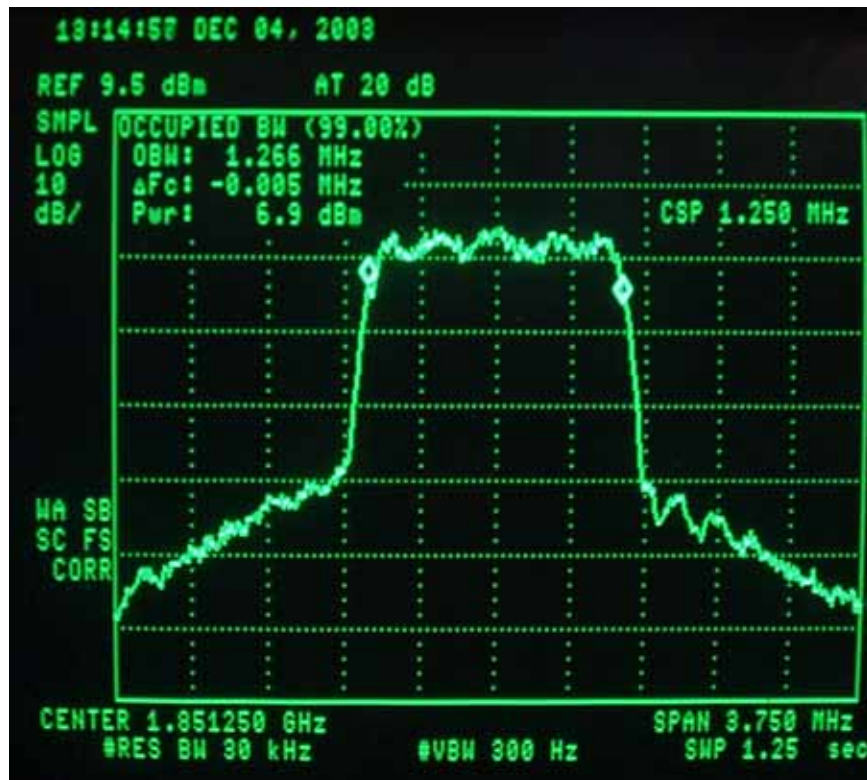



Figure 5-5: Occupied Bandwidth – CDMA 1900 Channel 600

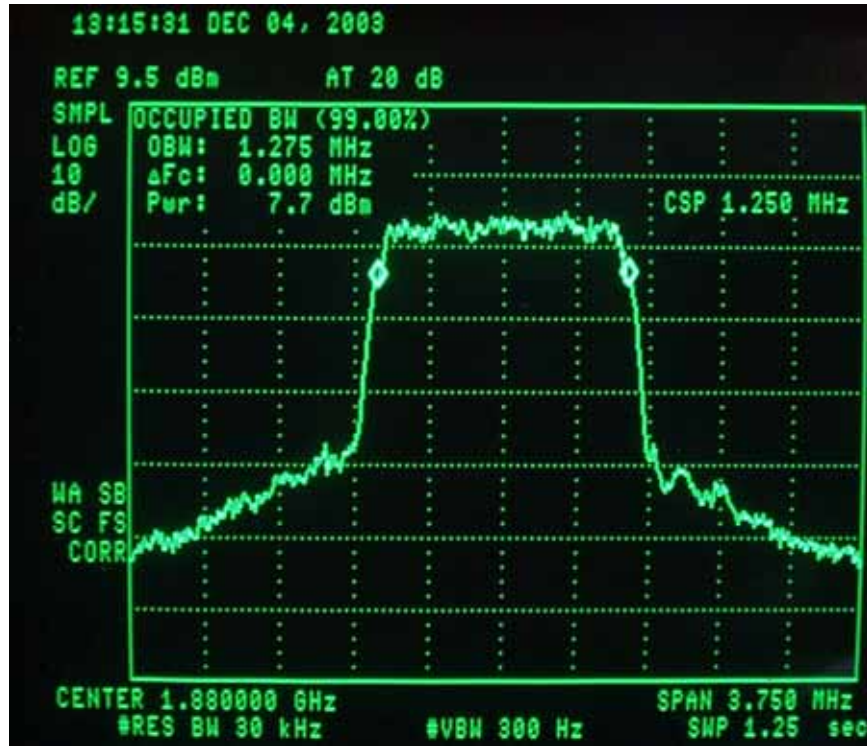
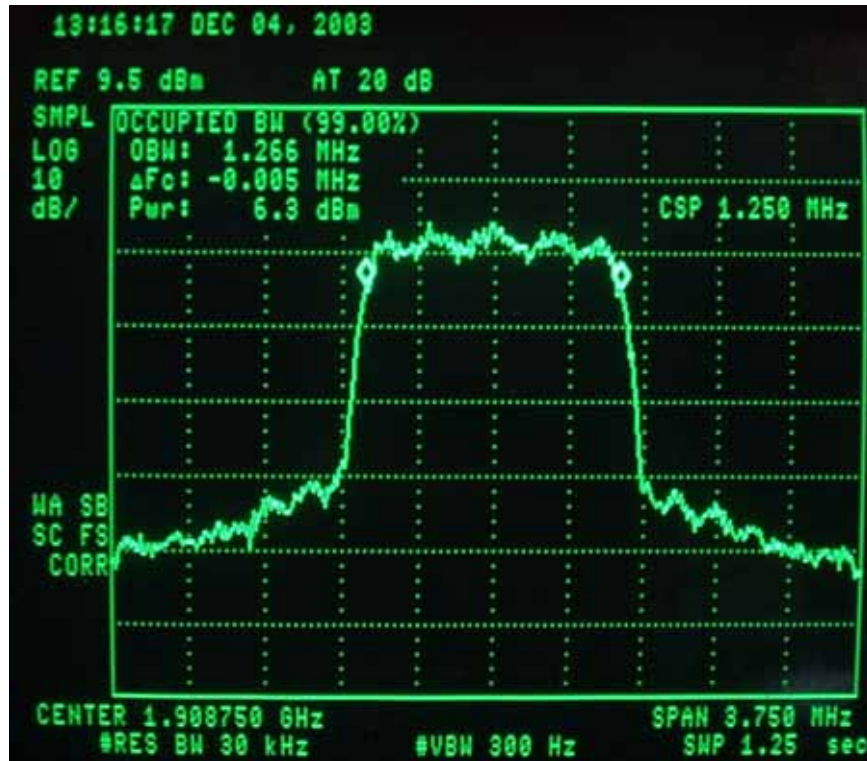

Figure 5-6: Occupied Bandwidth – CDMA 1900 Channel 1175





## 6 OUT OF BAND EMISSION AT ANTENNA TERMINALS

FCC §2.1047, FCC §22.905, FCC §22.917, FCC §24.238(a)

Out of band emissions. The power of any emission outside of the authorized operating frequency ranges must be attenuated below the transmitting power (P) by a factor of at least  $43 + 10 \log(P)$  dB.

### 6.1 Test Procedure

Measurement instrumentation was set to a resolution bandwidth of 1 MHz or greater. In the 1 MHz bands immediately outside and adjacent to the frequency block, a resolution bandwidth of at least one percent of the emission bandwidth of the fundamental emission of the transmitter may be employed.

The RF output of the transceiver was connected to a spectrum analyzer through appropriate attenuation. The transceiver was set to its maximum power level. Sufficient scans were taken to show the out of band Emissions if any up to 10th harmonic.

### 6.2 Test Equipment

Description	Manufacturer	Model Number	Serial Number
Spectrum Analyzer	HP	8566B	2134A01032
Attenuator	Weinschel	2	BK7890
Attenuator	Weinschel	2	BK2313

### 6.3 Test Results

*Table 6-1: Summary of test result locations*

Location	Mode (Band)	Channel	Description
Figure 6-1	CDMA 800	1013	Conducted spurious emissions, 30MHz to 10 GHz
Figure 6-2	CDMA 800	384	Conducted spurious emissions, 30MHz to 10 GHz
Figure 6-3	CDMA 800	777	Conducted spurious emissions, 30MHz to 10 GHz
Figure 6-4	CDMA 1900	25	Conducted spurious emissions, 30MHz to 20 GHz
Figure 6-5	CDMA 1900	600	Conducted spurious emissions, 30MHz to 20 GHz
Figure 6-6	CDMA 1900	1175	Conducted spurious emissions, 30MHz to 20 GHz
Figure 6-7	CDMA 800	1013	Emissions within 1 MHz of band edge
Figure 6-8	CDMA 800	777	Emissions within 1 MHz of band edge
Figure 6-9	CDMA 1900	25	Emissions within 1 MHz of band edge
Figure 6-10	CDMA 1900	1175	Emissions within 1 MHz of band edge

Figure 6-1: Out of band emissions at antenna terminals – CDMA 800 Channel 1013

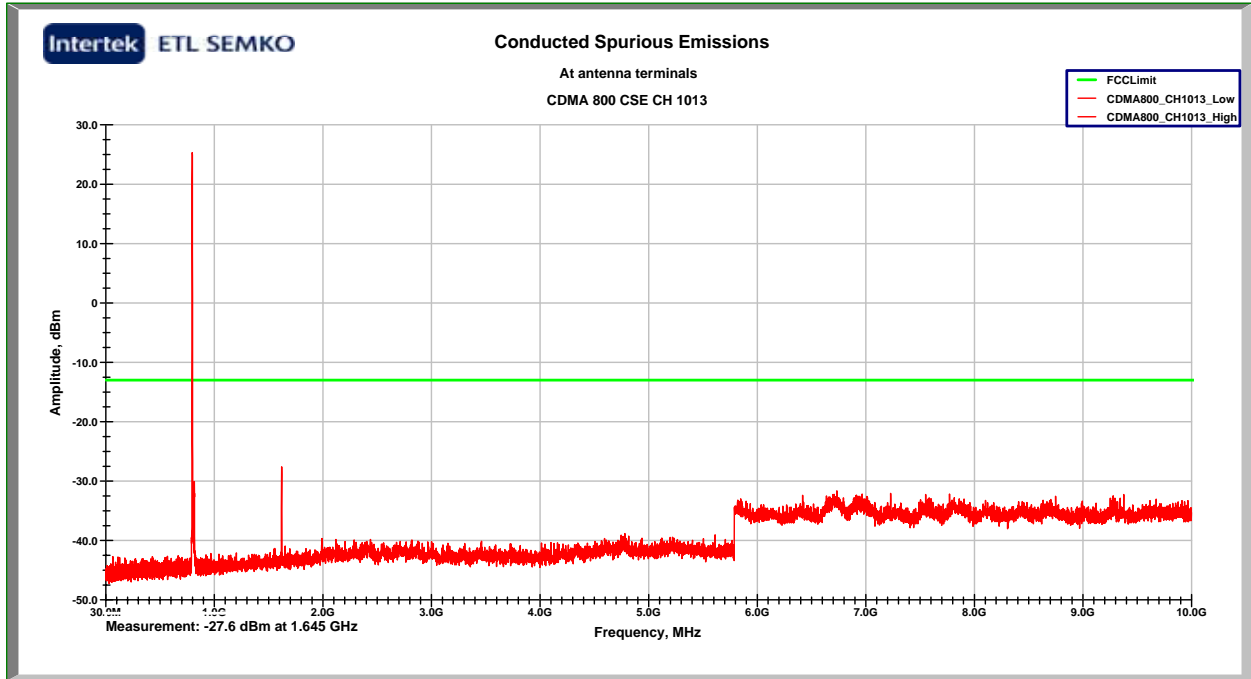

Figure 6-2: Out of band emissions at antenna terminals – CDMA 800 Channel 384

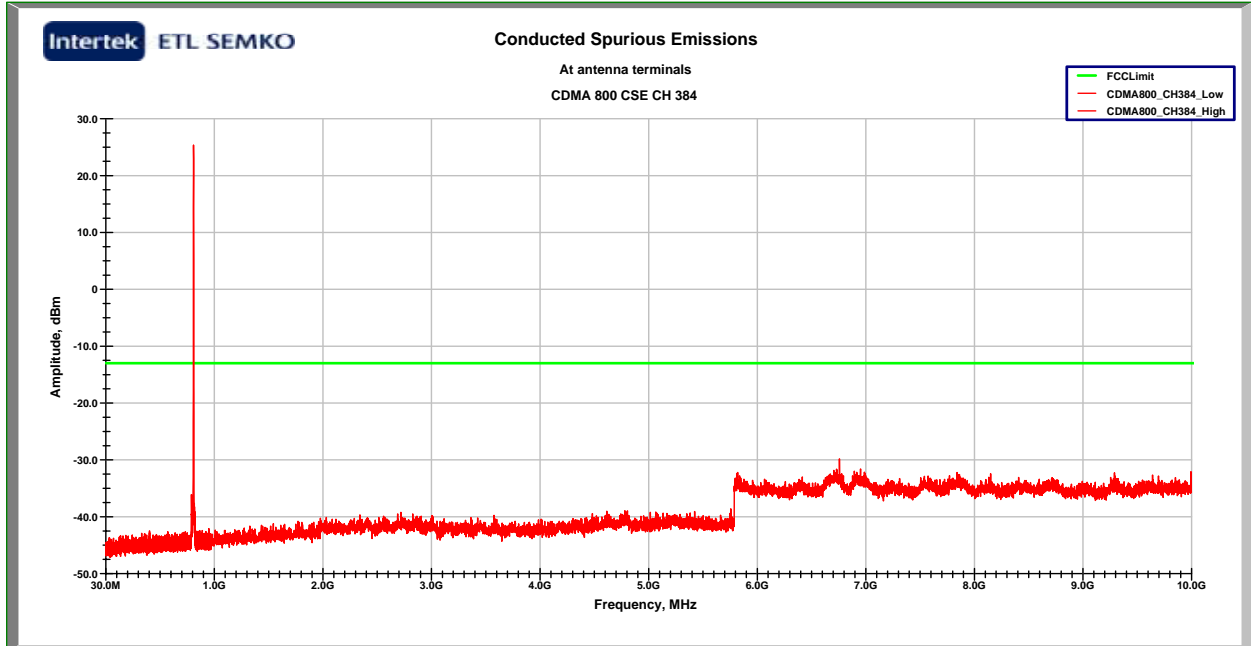

Figure 6-3: Out of band emissions at antenna terminals – CDMA 800 Channel 777

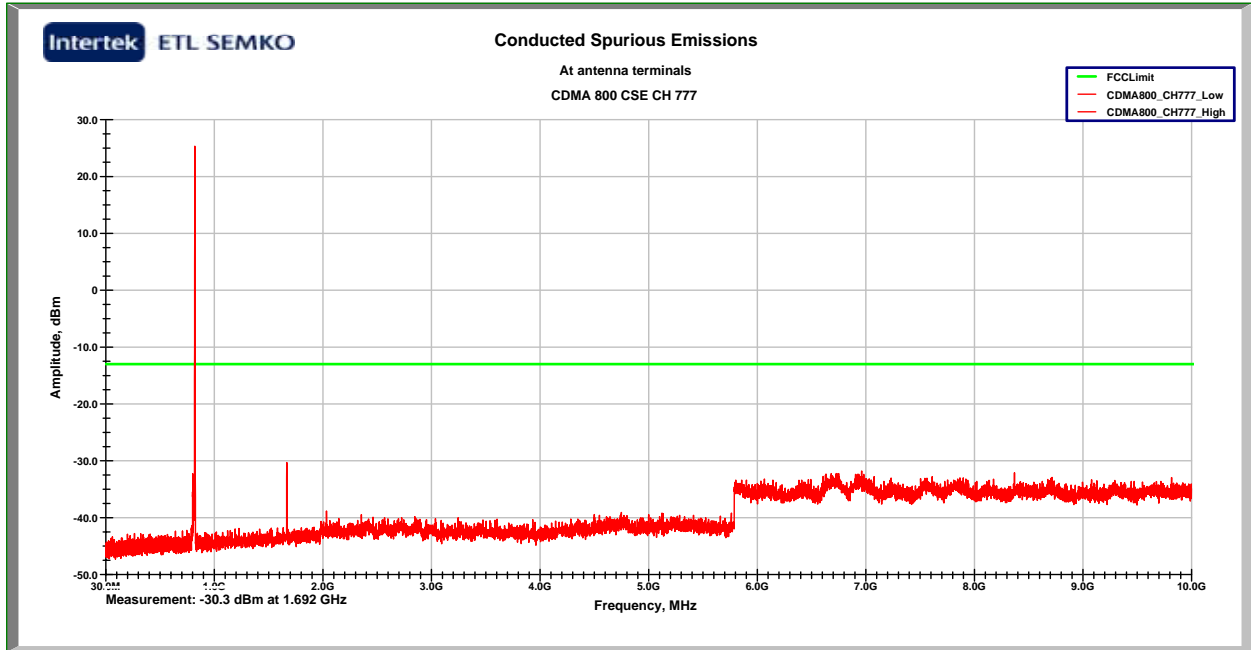

Figure 6-4: Out of band emissions at antenna terminals – CDMA 1900 Channel 25

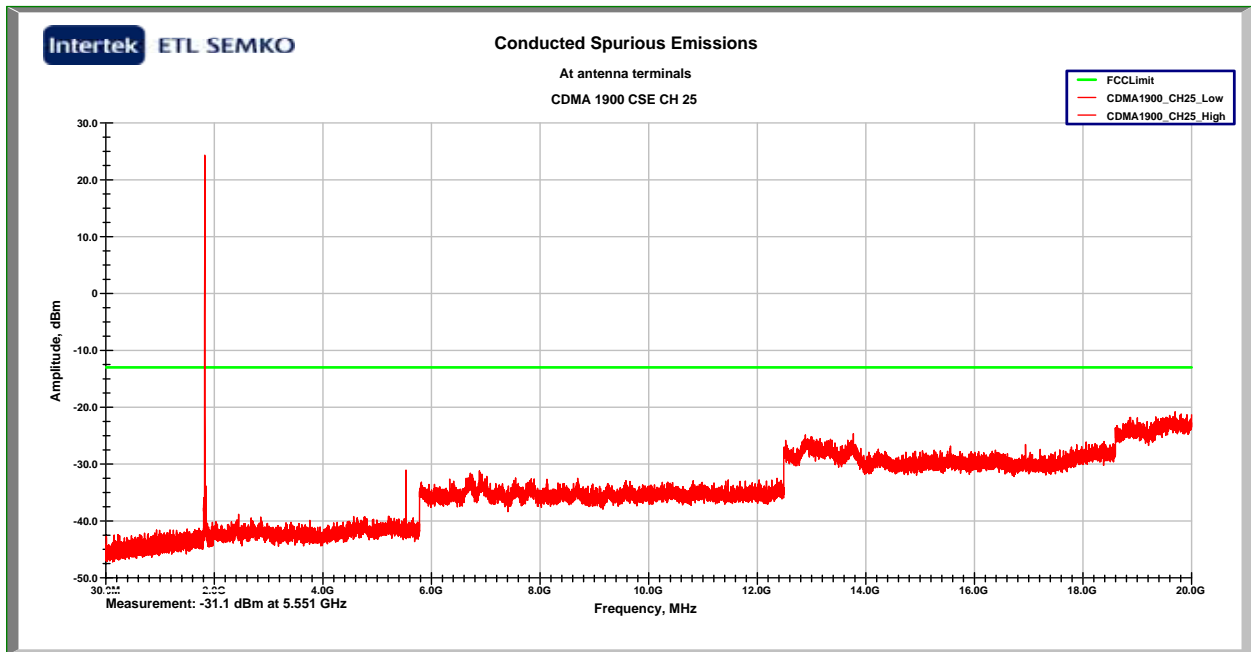

Figure 6-5: Out of band emissions at antenna terminals – CDMA 1900 Channel 600

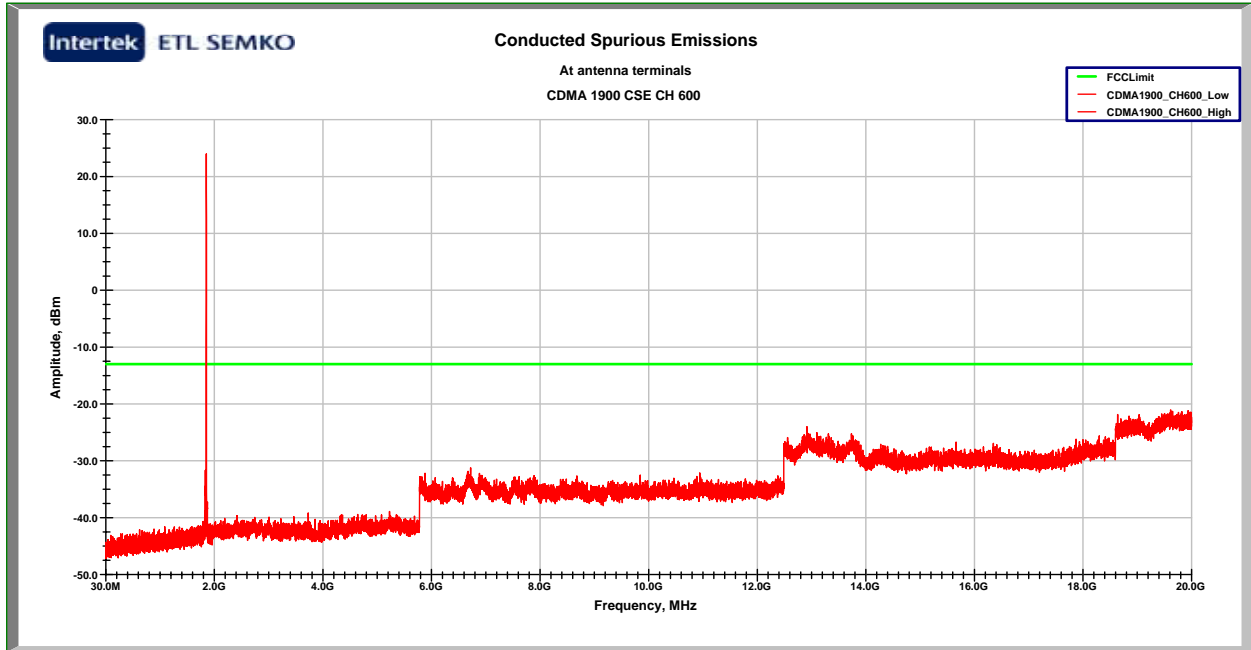

Figure 6-6: Out of band emissions at antenna terminals – CDMA 1900 Channel 1175

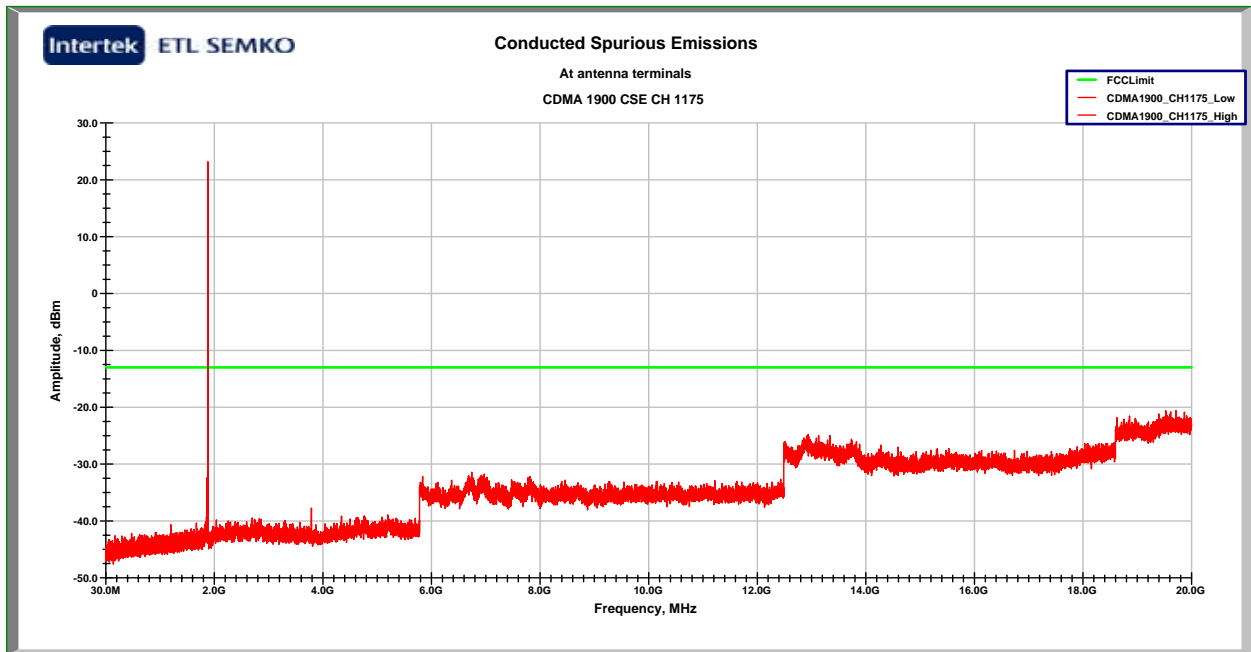

Figure 6-7: Emissions within 1 MHz of band edge, CDMA 800 Channel 1013

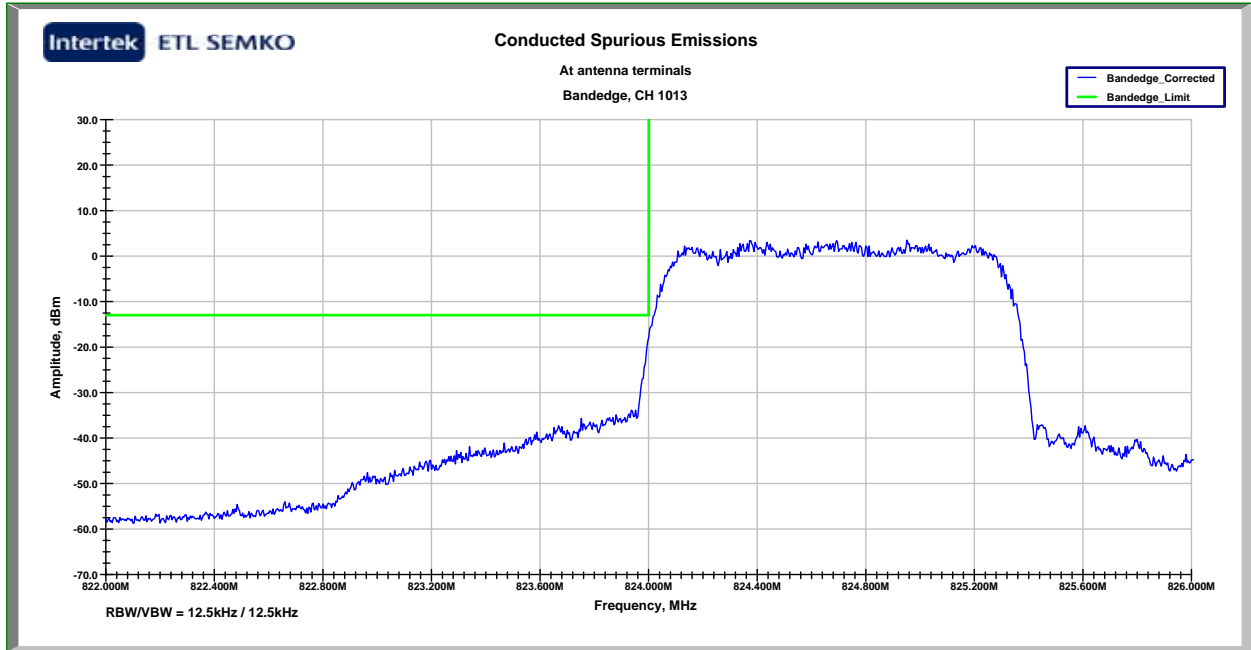

Figure 6-8: Emissions within 1 MHz of band edge, CDMA 800 Channel 777

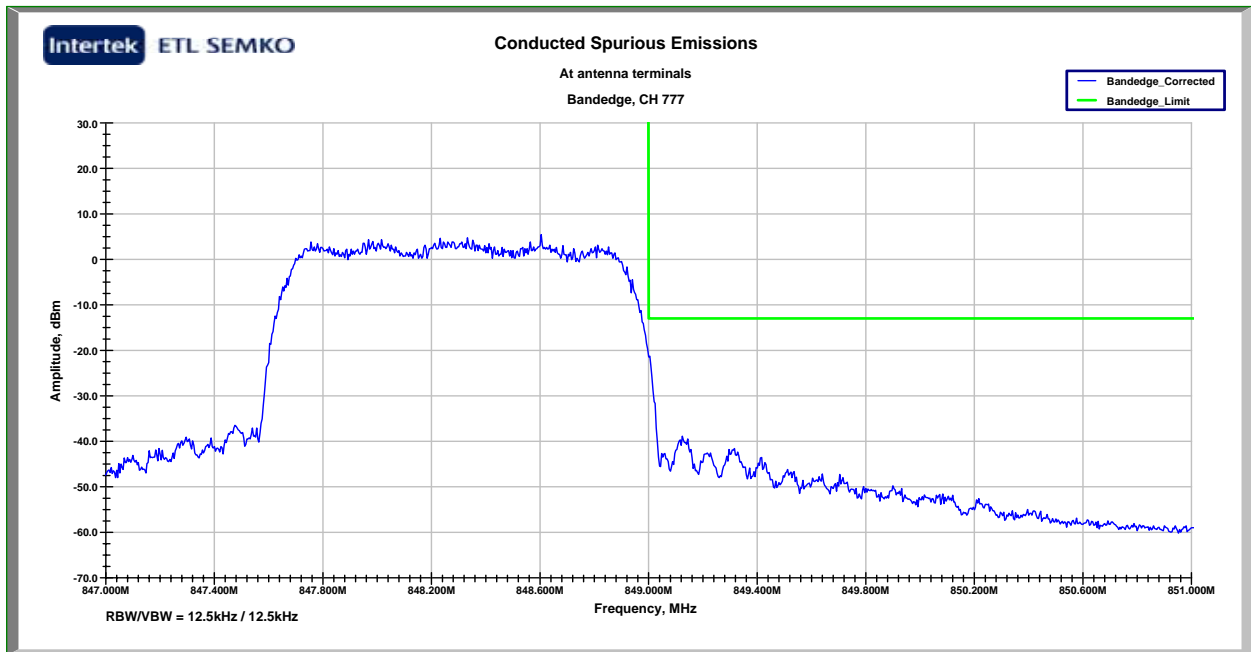

Figure 6-9: Emissions within 1 MHz of band edge, CDMA 1900 Channel 25

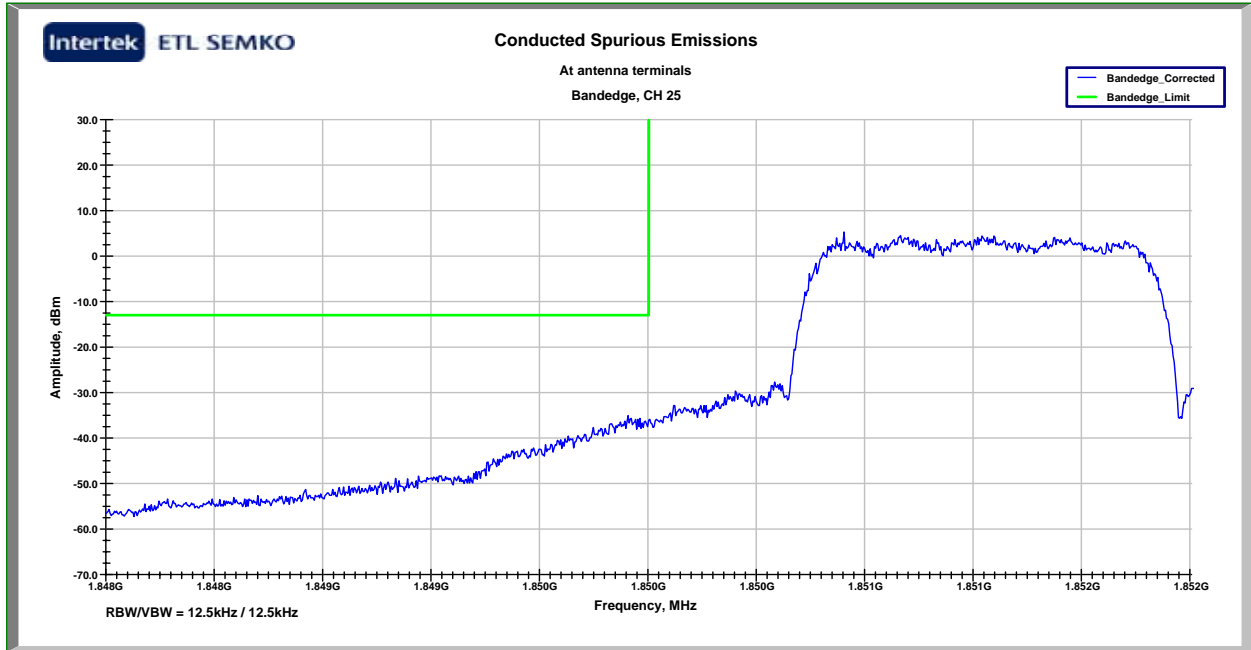
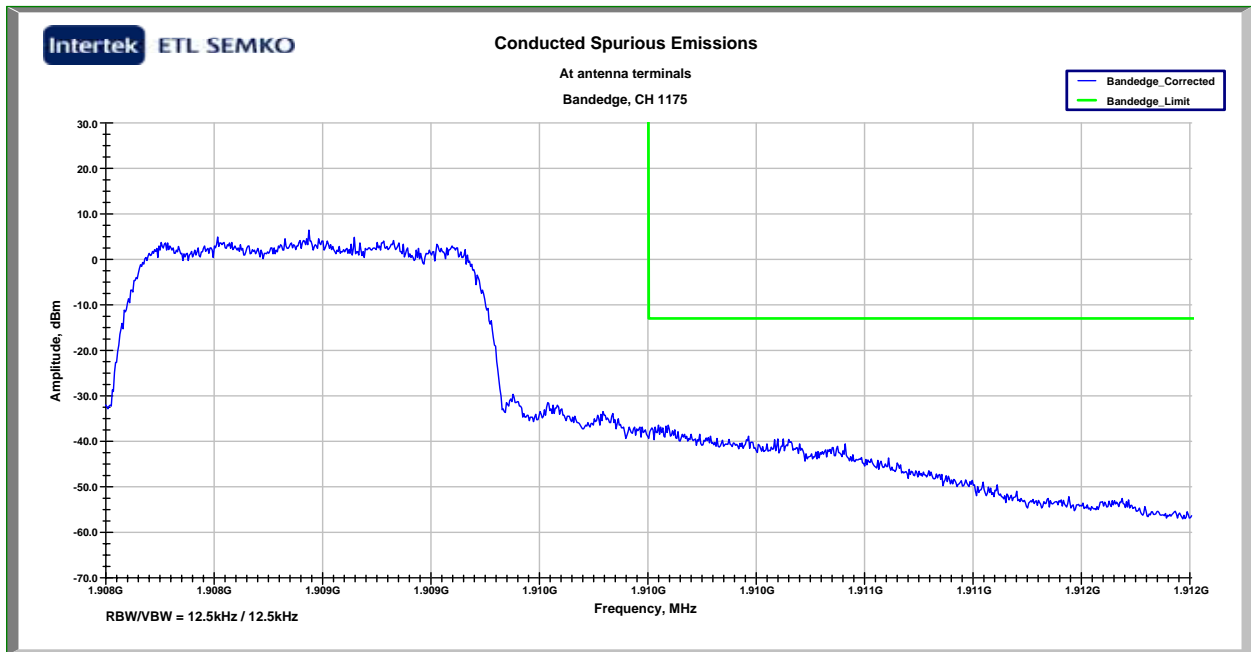

Figure 6-10: Emissions within 1 MHz of band edge, CDMA 1900 Channel 1175



**7 FIELD STRENGTH OF SPURIOUS RADIATION**

FCC §2.1053

**7.1 Test Procedure**

The EUT was placed on a non-conductive turntable with the earpiece attached. The earpiece was extended vertically above the EUT using a non-conductive support. The measurement antenna was placed at a distance of 3 meters from the EUT. During the tests, the antenna height and EUT azimuth were varied in order to identify the maximum level of emissions from the EUT. This maximization process was repeated with the EUT positioned in each of its three orthogonal orientations.

The frequency range up to tenth harmonic was investigated for each of three fundamental frequencies (low, middle, and high channels). Once spurious emissions were identified, the power of the emission was determined using the substitution method.

The spurious emissions attenuation was calculated as the difference between radiated power at the fundamental frequency and at the spurious emissions frequency.

**7.2 Test Equipment**

Description	Manufacturer	Model Number	Serial Number
Signal Generator	HP	83620B	3722A00537
Horn Antenna	EMCO	3115	9208-3919
Receive Antenna	Chase	CBL6112B	2622
Receive Antenna	AH Systems	SAS-200/571	246
EMI Receiver	HP	8546A	3410A00173
EMI Receiver, Preselector section	HP	85460A	3348A00203
Spectrum Analyzer	HP	8566B	2134A01032

**7.3 Test Results**

*Table 7-1: Tabular Test Results for Field Strength of Spurious Radiation*

Ant. Pol. (V/H)	Frequency MHz	Channel	EUT Reading dBm S1	Reading from Subs Antenna S2	Sig Gen Level dBm SG	Path Loss dB SG-S2	Antenna Gain dBi Horn only	Radiated Power dBm EIRP	Limit dBm EIRP	Margin dBm
CDMA 1900										
V	3701.940	25	-47.4	-14.8	-3.4	11.4	9.6	-26.4	-13.0	-13.4
H	3701.940	25	-50.2	-15.2	-3.4	11.8	9.8	-28.6	-13.0	-15.6
V	5552.420	25	-62.0	-21.5	-5.1	16.4	10.4	-35.2	-13.0	-22.2
H	5552.420	25	-59.4	-23.0	-5.1	17.9	10.4	-31.1	-13.0	-18.1
V	3760.200	600	-46.6	-14.8	-3.4	11.4	9.6	-25.6	-13.0	-12.6
H	3760.200	600	-48.4	-15.2	-3.4	11.8	9.8	-26.8	-13.0	-13.8
V	5639.540	600	-61.7	-21.5	-5.1	16.4	10.4	-34.9	-13.0	-21.9
H	5639.540	600	-59.7	-23.0	-5.1	17.9	10.4	-31.4	-13.0	-18.4
V	3817.860	1175	-39.5	-14.8	-3.4	11.4	9.6	-18.5	-13.0	-5.5
H	3817.860	1175	-45.2	-15.2	-3.4	11.8	9.8	-23.6	-13.0	-10.6
V	5726.100	1175	-53.7	-21.5	-5.1	16.4	10.4	-26.9	-13.0	-13.9
H	5726.100	1175	-59.8	-23.0	-5.1	17.9	10.4	-31.5	-13.0	-18.5



Figure 7-1: Measured Field Strength of Spurious Radiation CDMA 800, Channel 1013

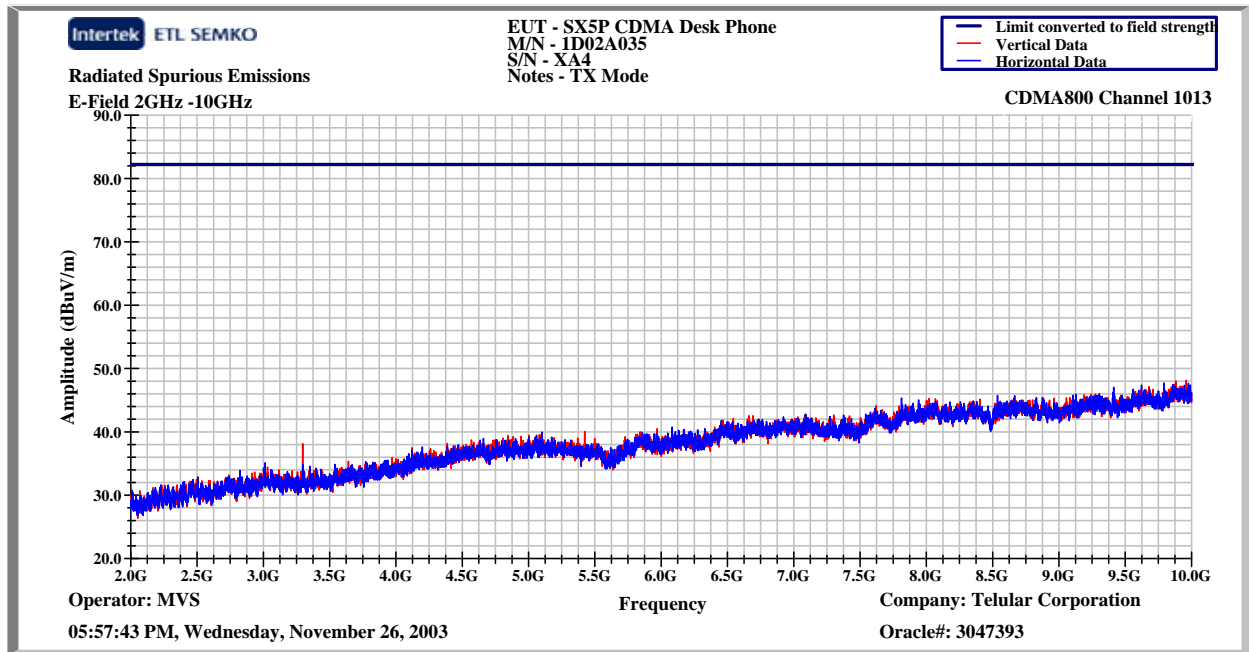
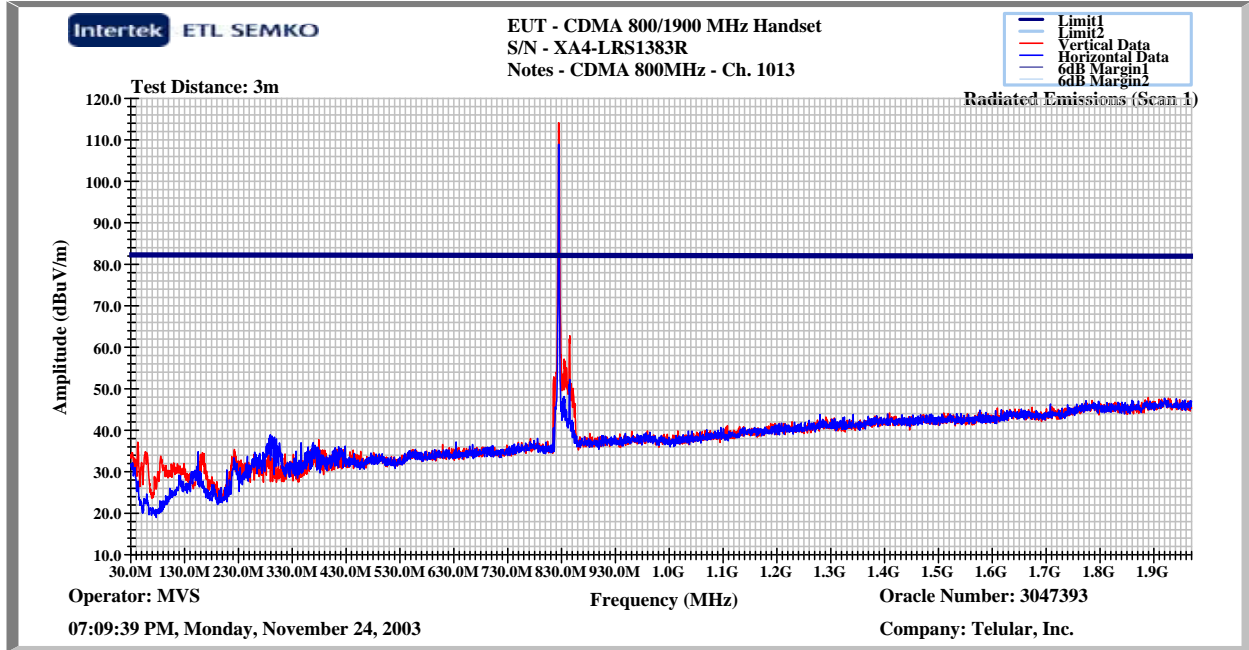

Figure 7-2: Measured Field Strength of Spurious Radiation CDMA 800, Channel 384

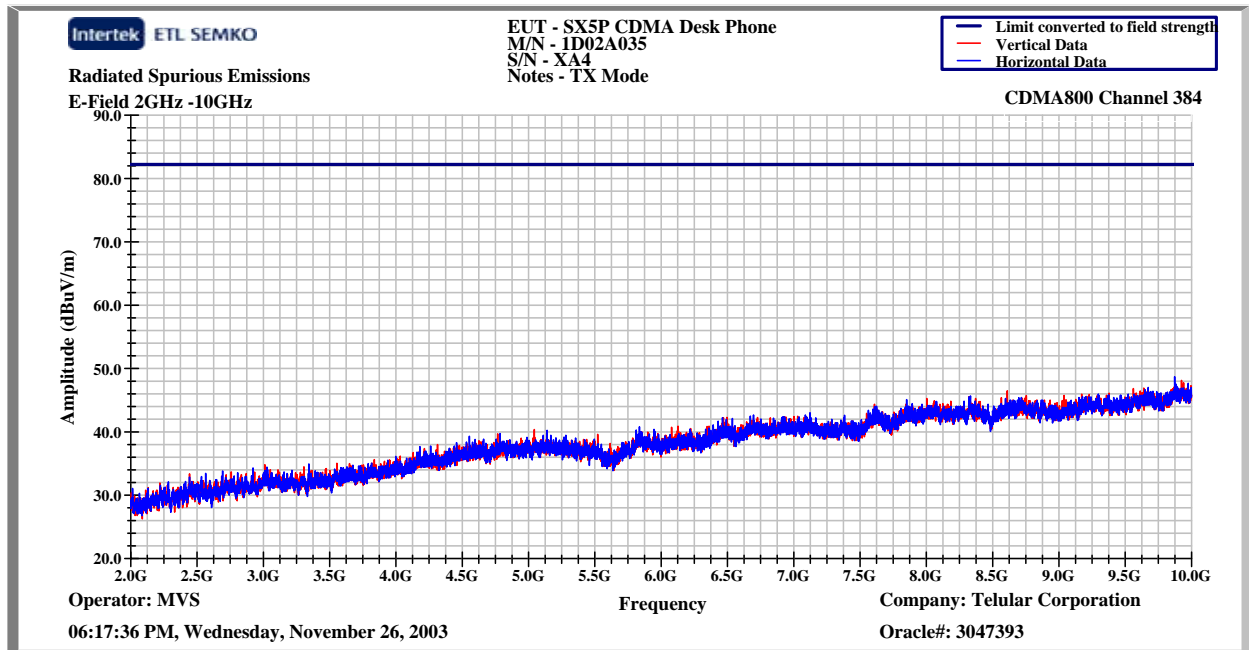
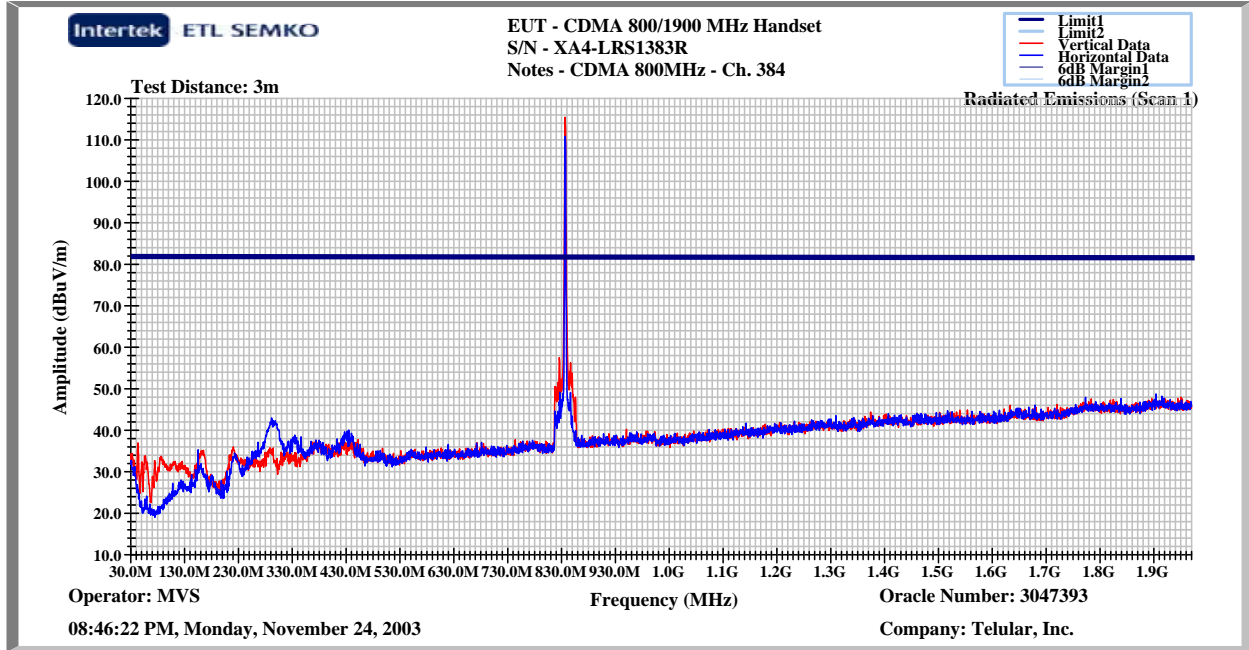

Figure 7-3: Measured Field Strength of Spurious Radiation CDMA 800, Channel 777

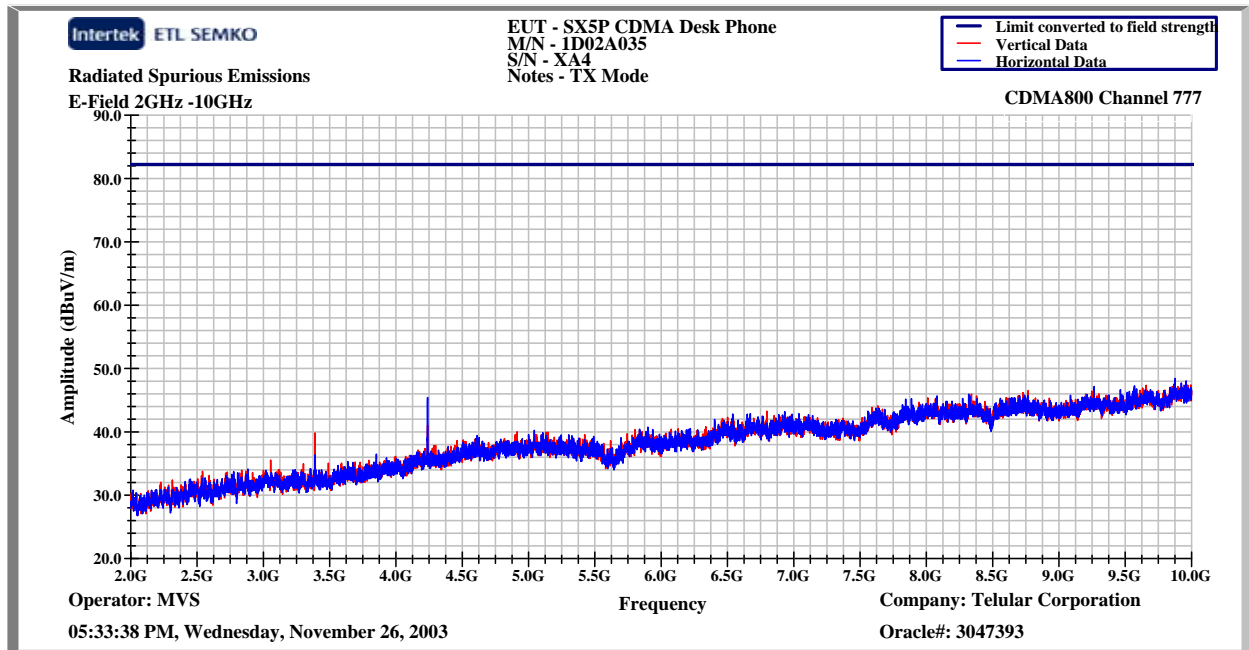
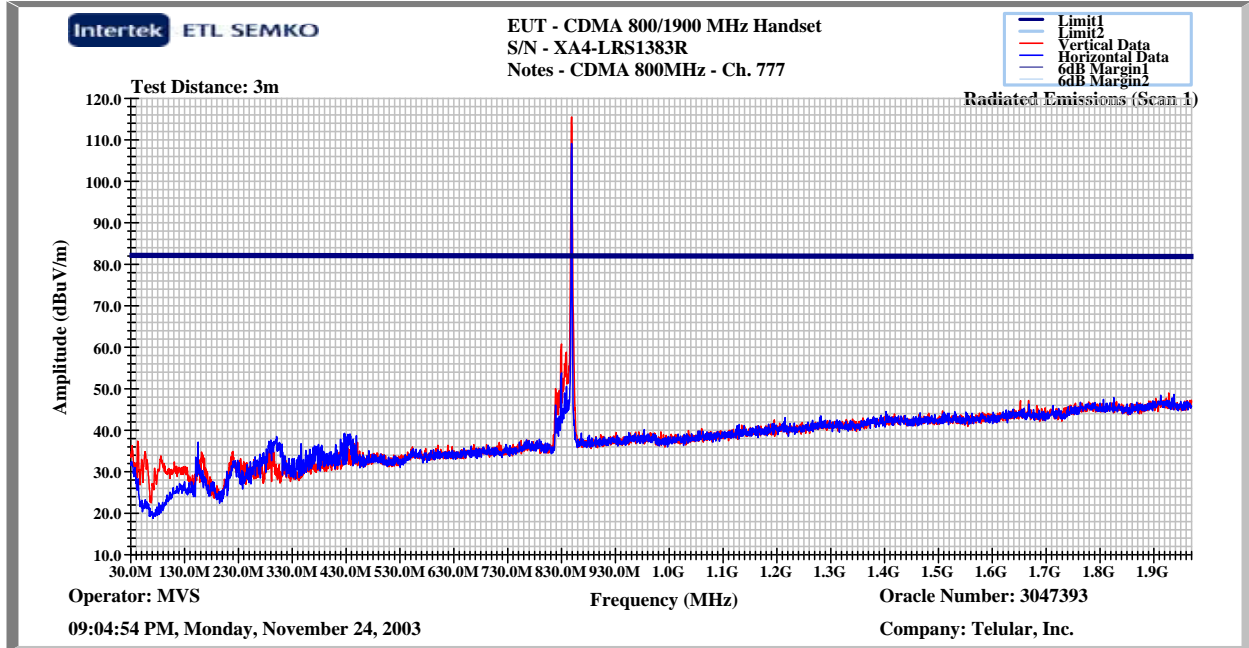

Figure 7-4: Measured Field Strength of Spurious Radiation CDMA 1900, Channel 25

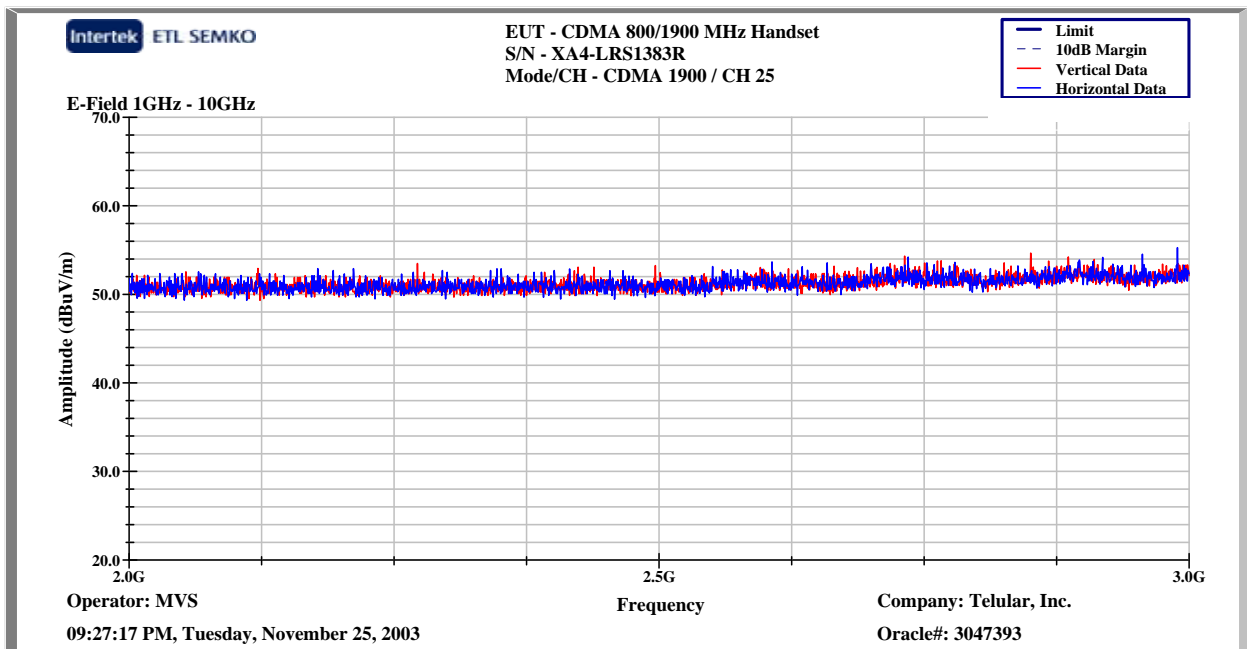
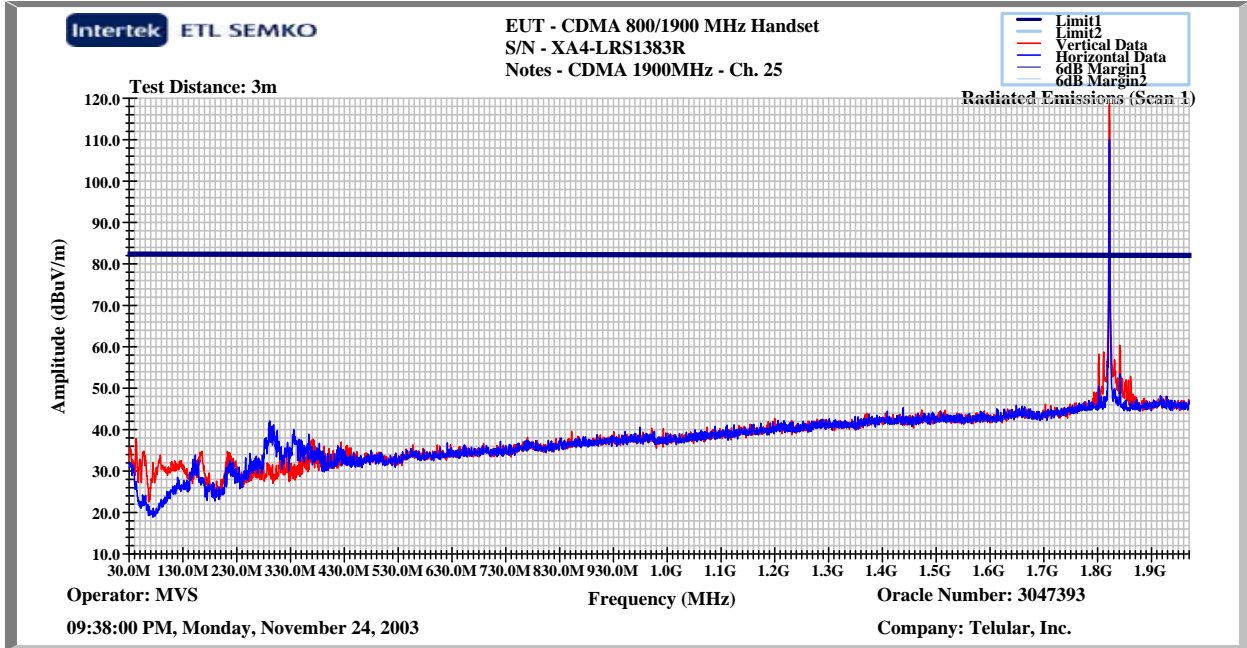

Figure 7-5: Measured Field Strength of Spurious Radiation CDMA 1900, Channel 25

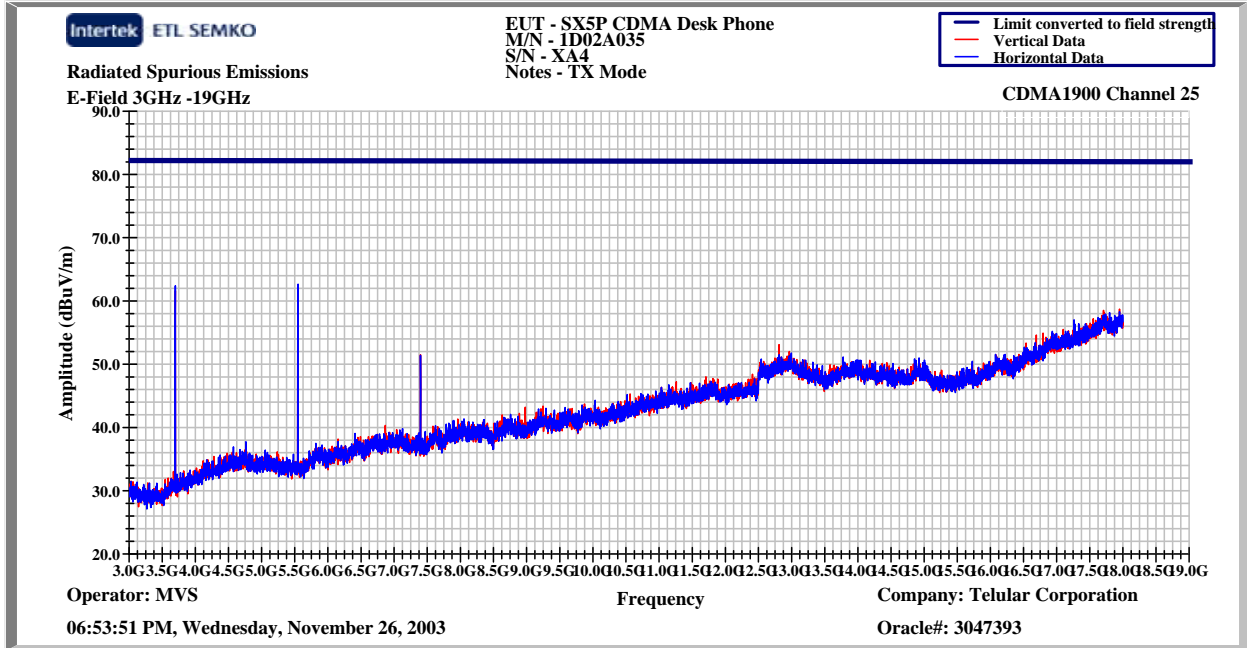

Figure 7-6: Measured Field Strength of Spurious Radiation CDMA 1900, Channel 600

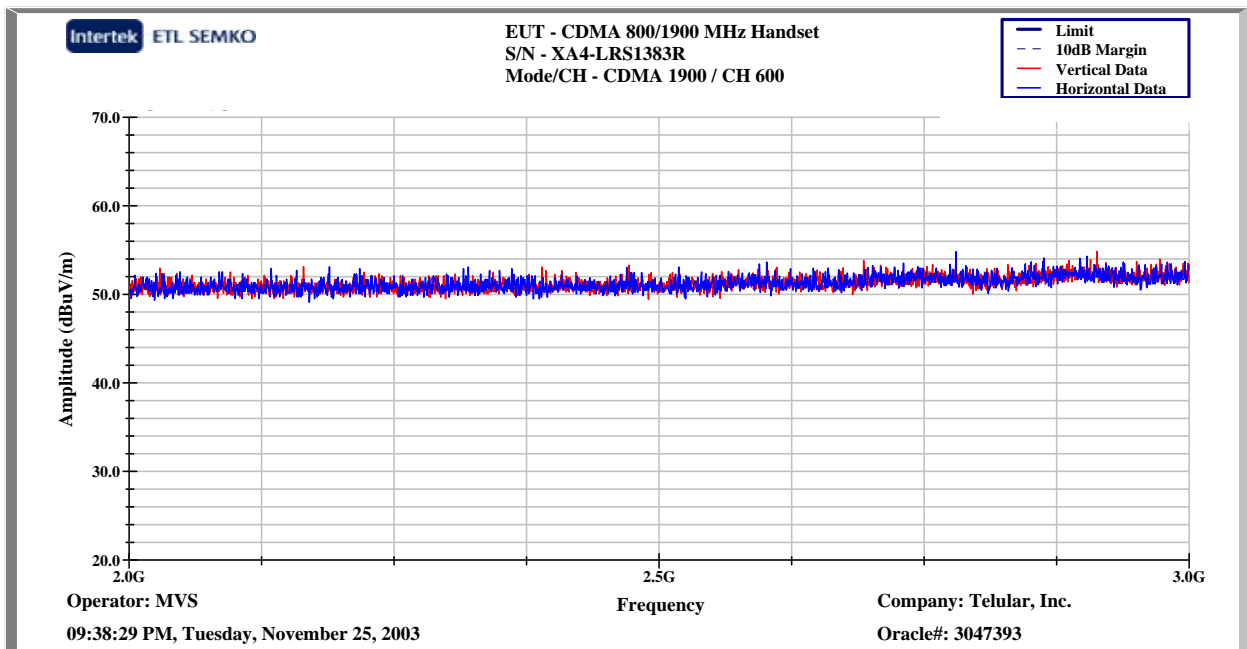
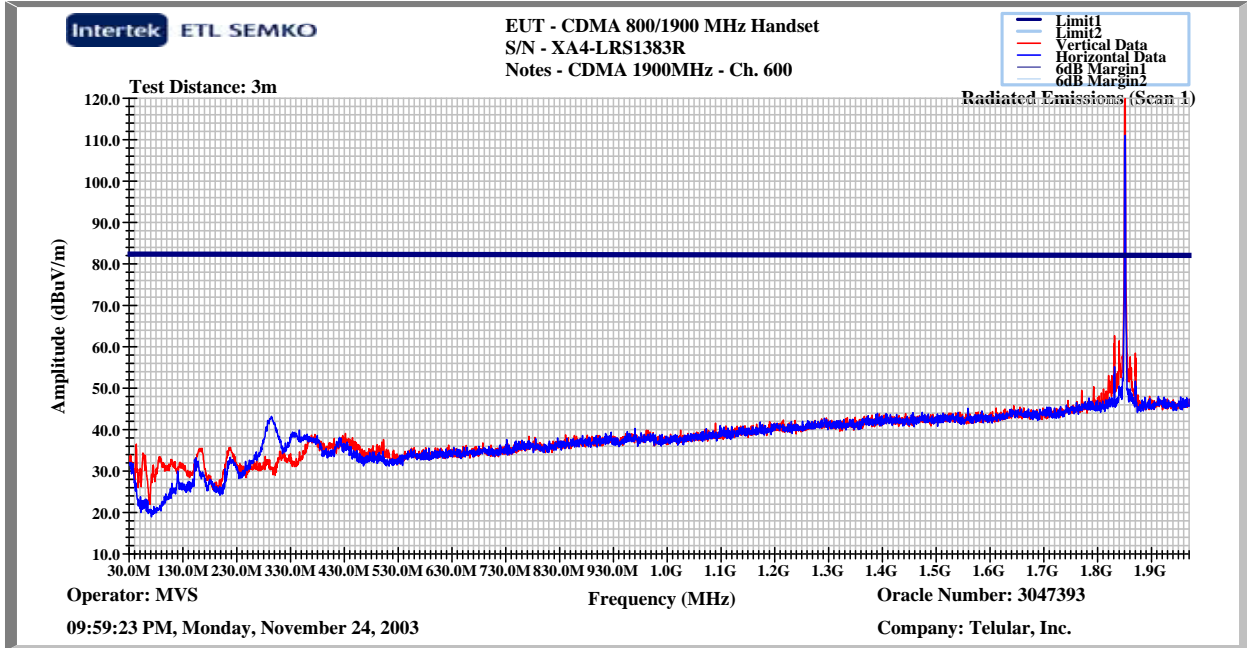

Figure 7-7: Measured Field Strength of Spurious Radiation CDMA 1900, Channel 600

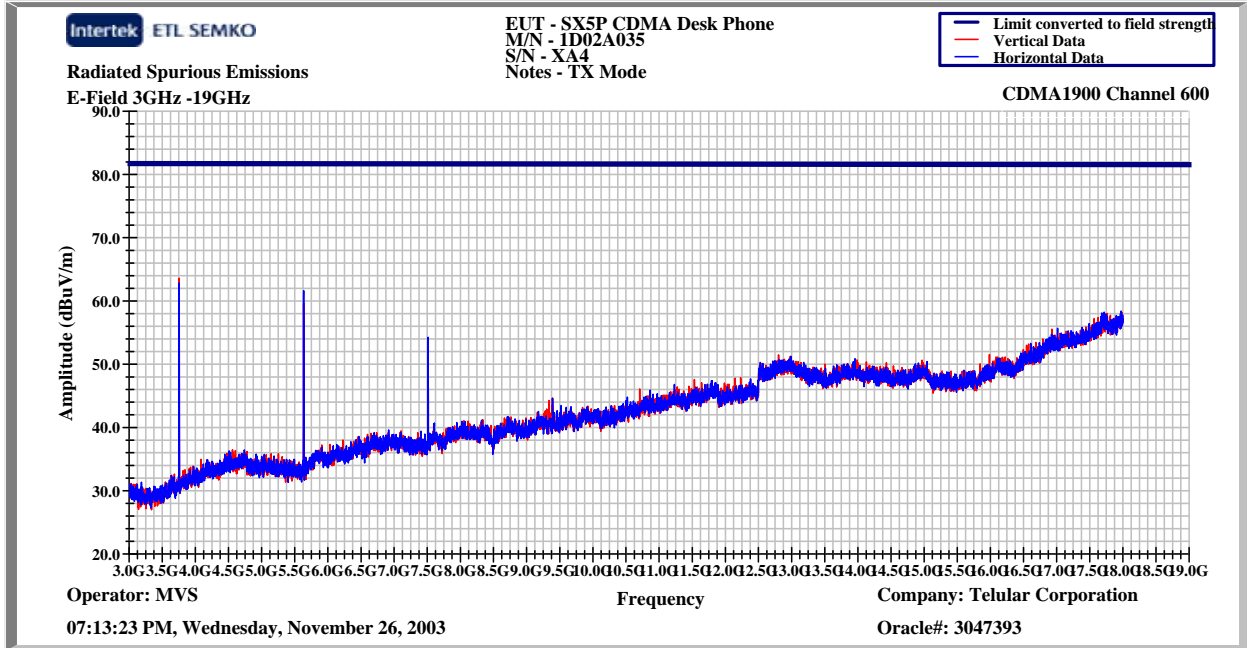

Figure 7-8: Measured Field Strength of Spurious Radiation CDMA 1900, Channel 1175

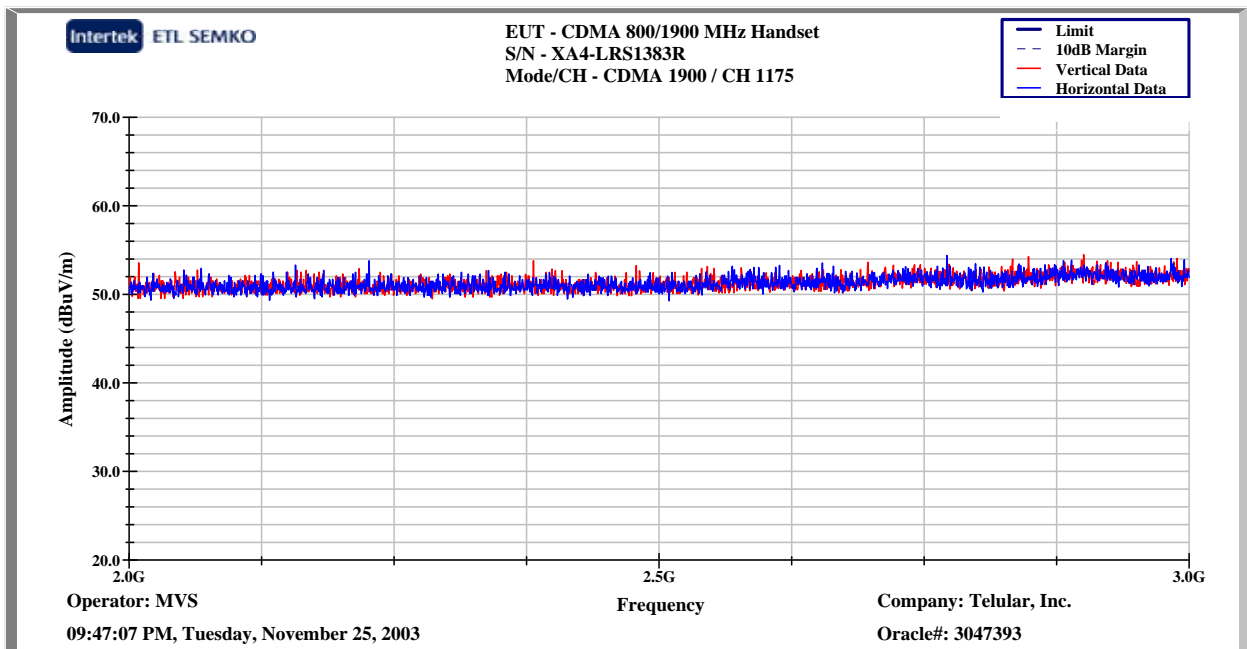
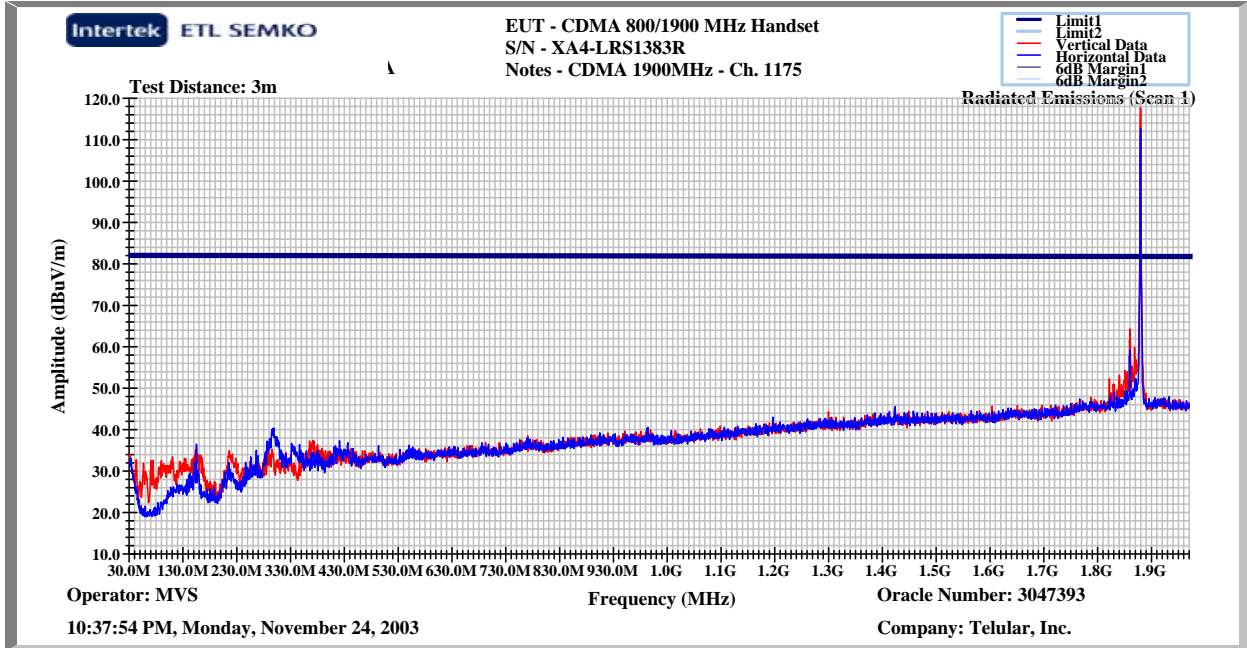
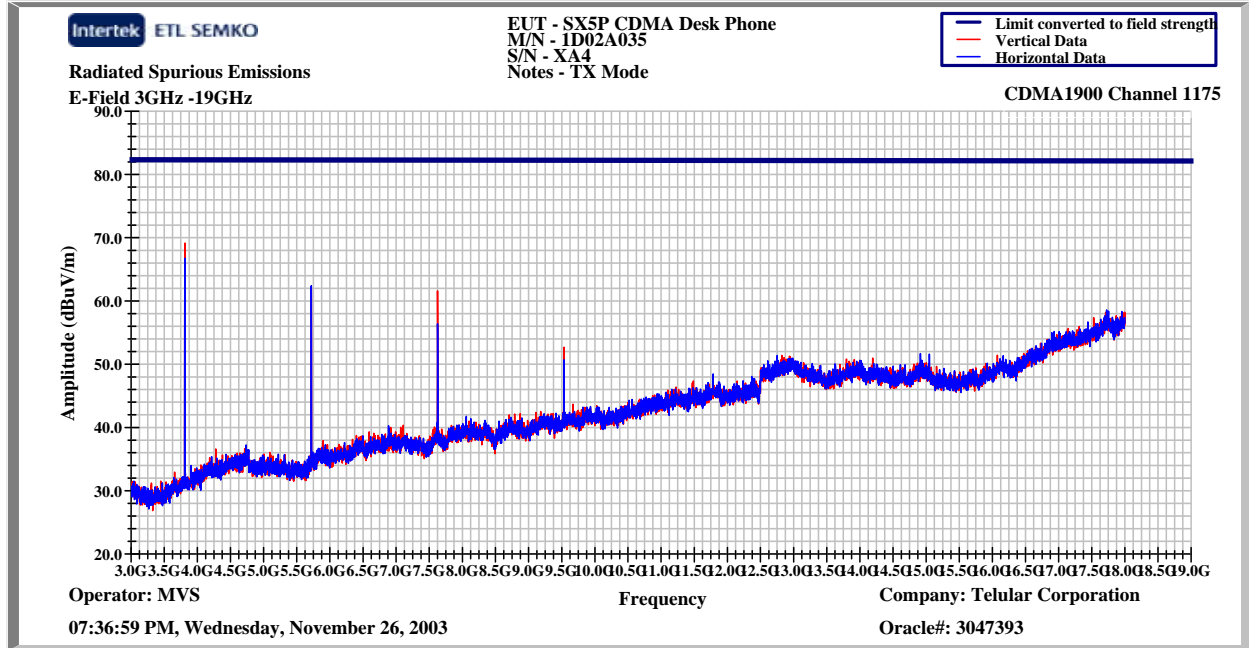



Figure 7-9: Measured Field Strength of Spurious Radiation CDMA 1900, Channel 1175



## 8 POWER LINE CONDUCTED EMISSIONS

FCC §15.107, FCC §15.207

### 8.1 Test Procedure

Measurements are carried out using quasi-peak and average detector receivers in accordance with CISPR 16. An AMN is required to provide a defined impedance at high frequencies across the power feed at the point of measurement of terminal voltage and also to provide isolation of the circuit under test from the ambient noise on the power lines. An AMN as defined in CISPR 16 shall be used.

The EUT is located so that the distance between the boundary of the EUT and the closest surface of the AMN is 0.8m.

Where a flexible mains cord is provided by the manufacturer, this shall be 1m long or if in excess of 1m, the excess cable is folded back and forth as far as possible so as to form a bundle not exceeding 0.4m in length.

The EUT is arranged and connected with cables terminated in accordance with the product specification.

Conducted disturbance is measured between the phase lead and the reference ground, and between the neutral lead and the reference ground. Both measured values are reported.

The EUT, where intended for tabletop use, is placed on a table whose top is 0.8m above the ground plane. A vertical, metal reference plane is placed 0.4m from the EUT. The vertical metal reference-plane is at least 2m by 2m. The EUT shall be kept at least 0.8m from any other metal surface or other ground plane not being part of the EUT. The table is constructed of non-conductive materials. Its dimensions are 1m by 1.5m, but may be extended for larger EUT.

Equipment setup for conducted disturbance tests followed the guidelines of ANSI C63.4: 1992.

### 8.2 Test Equipment

Description	Manufacturer	Model Number	Serial Number
EMI Receiver	HP	8546A	3410A00173
LISN	FCC	FCC-LISN-50-50-2M	2019

8.3 Test Results

Figure 8-1: FCC §15.107 and §15.207 power line conducted emissions (peak)

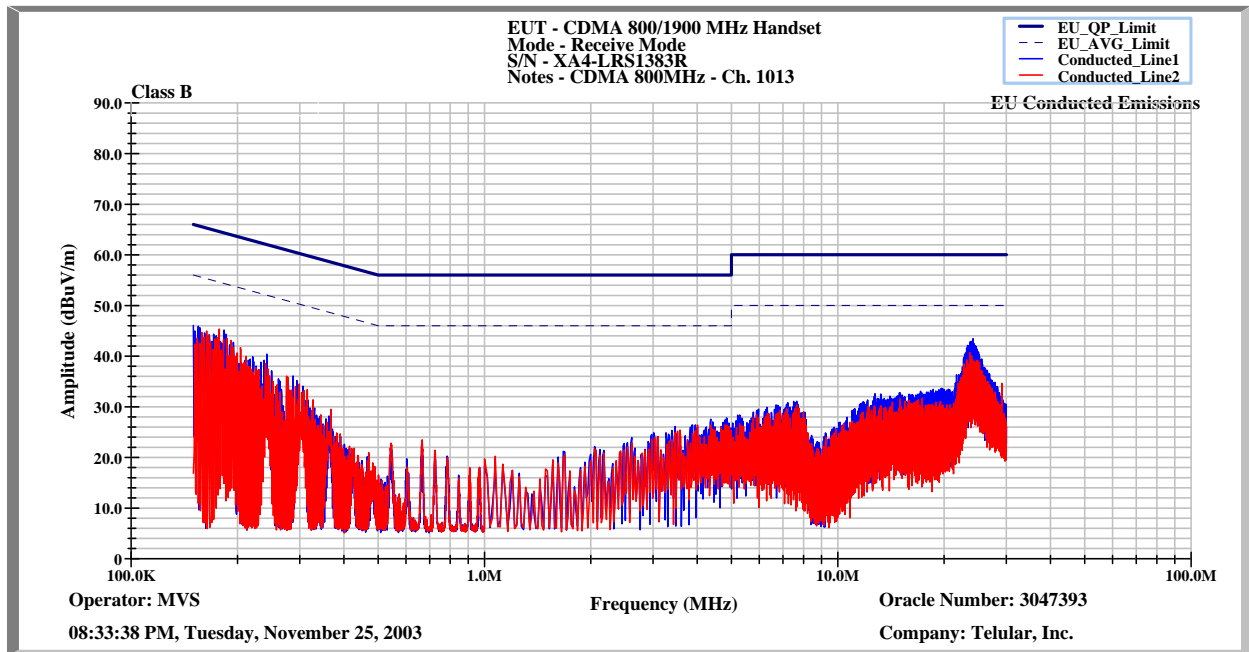
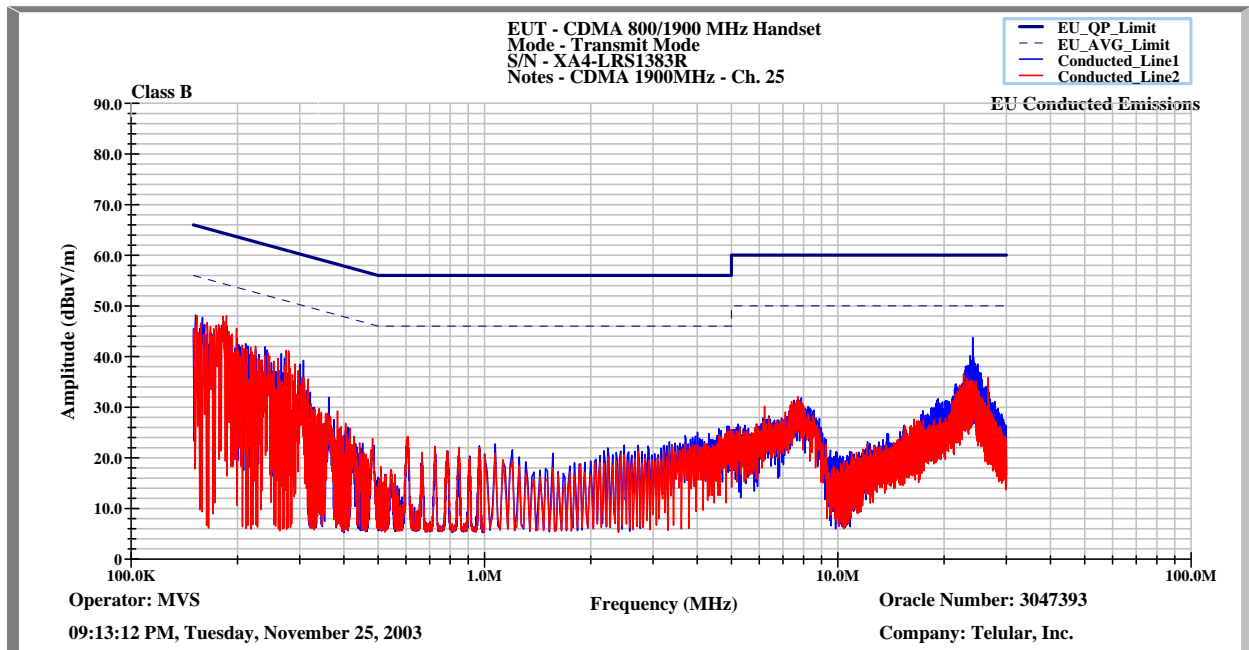

Figure 8-2: FCC §15.107 and §15.207 power line conducted emissions (peak)



**9 FREQUENCY STABILITY VS TEMPERATURE**

FCC §2.1055, FCC §22.355, FCC §24.235

Frequency tolerance: 2.5ppm

**9.1 Test Procedure**

Frequency Stability vs. Temperature

The equipment under test was connected to an external power supply and the RF output was connected to a base station simulator. The EUT was placed inside the temperature chamber. The power lead and RF output cable, and control cable (if applicable) exited the chamber through an opening.

After the temperature stabilized for approximately 30 minutes, the transmitter was activated, and the frequency error was recorded. The procedure was repeated every 10 degrees from -30 to +60 degrees Celsius.

Frequency Stability vs. Input Voltage

For mains powered equipment, the frequency error was recorded with the input voltage set to 115%, 100% and 85% of the nominal value. For DC powered equipment, the frequency error was recorded with the input voltage set to nominal, at the battery endpoint and at least 3 point between.

**9.2 Test Equipment**

Description	Manufacturer	Model Number	Serial Number
Base Station Simulator	Rhode & Schwarz	CMU-200	837198/089
Temperature Chamber	Thermotron	SM-8C	32692
PMA	Solar Light Co.	PMA 2100	5462
Temperature Probe	Solar Light Co.	PMA 2170	6613
Variable Transformer	Power Stat	3PN126	289290
Multi-meter	Fluke	23	43530108
Power Supply	Keithley	2304	Asset #2288

**9.3 Test Results**

*Table 4-1: CDMA 800 Channel 384, Frequency stability vs. Temperature*

Frequency Error (Hz) vs. Temp.						
Temp (C)	CDMA 800			CDMA 1900		
	384	777	1013	25	600	1175
60	-1	-1	0	-2	-4	-2
50	-1	-1	-1	-2	-2	-1
40	-1	-2	-3	-2	-3	-2
30	-1	-3	-3	-1	0	-3
20	-1	-1	-1	-4	-1	-3
10	-2	-1	-1	-2	-5	-2
0	-1	-1	0	-2	-2	-3
-10	0	0	0	-1	-1	-3
-20	-1	0	-1	-1	-1	-4
-30	0	0	-1	-3	-3	-2

Frequency Error (Hz) vs. Input voltage						
Voltage	CDMA 800			CDMA 1900		
	384	777	1013	25	600	1175
138 Vac	-1	-1	-1	-4	-3	-2
120 Vac	-1	0	0	-3	-2	-3
102 Vac	-1	-1	-1	-3	-1	-3

6.0 Vdc	-1	-1	-1	-1	-3	-2
5.5 Vdc	0	0	-1	-3	-3	-3
5.0 Vdc	-1	0	0	-3	-2	-2
4.5 Vdc	0	0	1	0	0	0
4.0 Vdc	34	35	19	-19	-121	-130
3.9 Vdc	46	49	26	53	-105	-240

**10 RECEIVER SPURIOUS EMISSIONS**

**10.1 Test Limits**

*Table 10-1 Radiated Emission Limit for FCC §15.109*

Radiated Emission Limits at 3 meters	
Frequency (MHz)	Quasi-Peak limits, dB (μV/m)
30 to 88	40.0
88 to 216	43.5
216 to 960	46.0
960 and up	54.0

**10.2 Test Equipment**

Description	Manufacturer	Model Number	Serial Number
Horn Antenna	EMCO	3115	9208-3919
BiConLog Antenna	Chase	CBL6112B	2622
EMI Receiver	HP	8546A	3410A00173
EMI Receiver, Preselector section	HP	85460A	3348A00203

## 10.3 Test Procedure

Measurements are made over the frequency range of 30 MHz to five times the highest frequency operating within the device. The measuring receiver meets the requirements of Section One of CISPR 16 and the measuring antenna correlates to a balanced dipole. From 30 to 1000 MHz, a quasi-peak detector was used for measurement. Above 1000 MHz, average measurements were performed.

Measurements of the radiated field are made with the antenna located at a distance of 3 meters from the EUT. If the field-strength measurements at 3m cannot be made because of high ambient noise level or for other reasons, measurements may be made at a closer distance, for example 1m. An inverse proportionality factor of 20 dB per decade should be used to normalize the measured data to the specified distance for determining compliance.

The antenna is adjusted between 1m and 4m in height above the ground plane for maximum meter reading at each test frequency.

The antenna-to-EUT azimuth is varied during the measurement to find the maximum field-strength readings.

The antenna-to-EUT polarization (horizontal and vertical) is varied during the measurements to find the maximum field-strength readings.

The EUT, where intended for tabletop use, is placed on a table whose top is 0.8m above the ground plane. The table is constructed of non-conductive materials. Its dimensions are 1m by 1.5m, but may be extended for larger EUT.

Equipment setup for radiated disturbance tests followed the guidelines of ANSI C63.4: 1992.

10.4 Test Results

Figure 10-1 FCC §15.109 Receiver Spurious Emissions

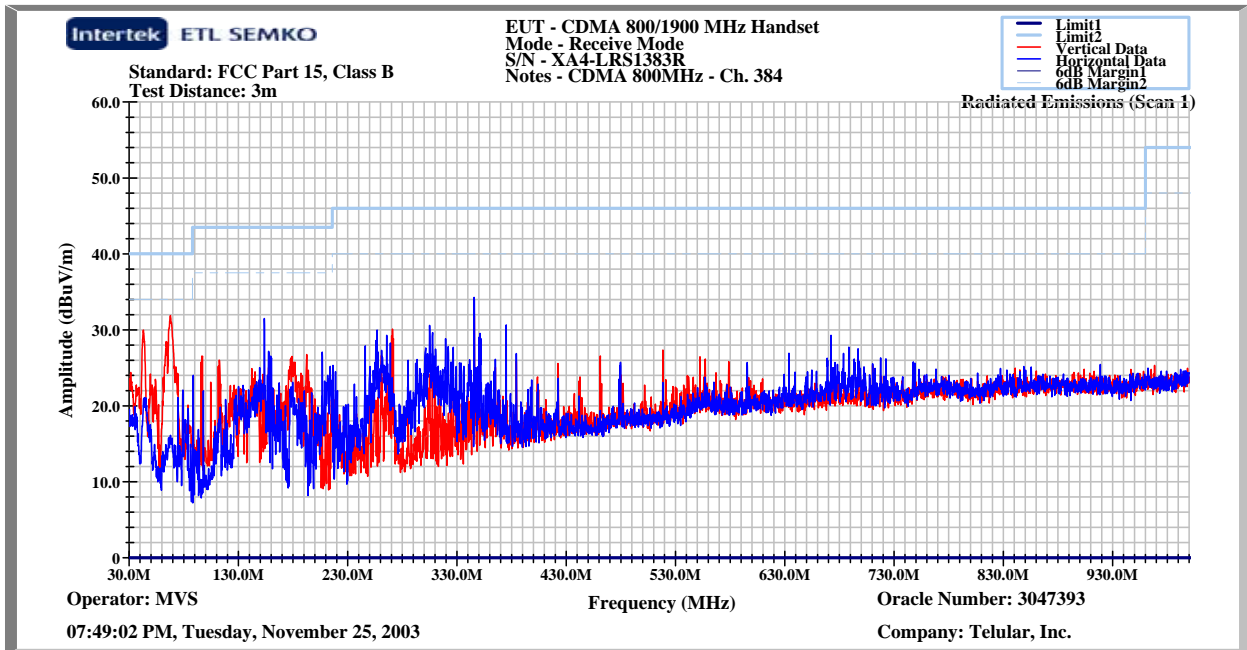
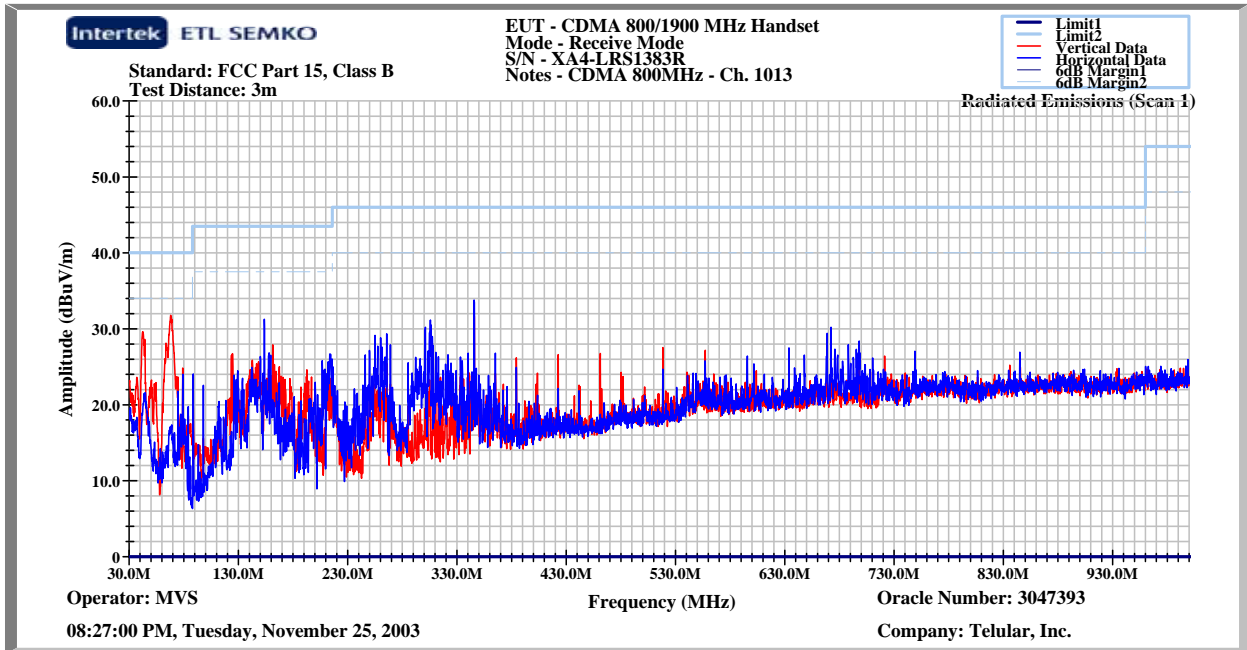



Figure 10-2 FCC §15.109 Receiver Spurious Emissions

