

FCC Test Report

Report No.: RF170425C26-8

FCC ID: MSQZ01KD

Test Model: ASUS_Z01KD

Received Date: Apr. 25, 2017

Test Date: May 27, 2017 ~ Jul. 06, 2017

Issued Date: Aug. 08, 2017

Applicant: ASUSTek COMPUTER INC.

Address: 4F, No. 150, LI-TE Rd., PEITOU, TAIPEI 112, TAIWAN

Issued By: Bureau Veritas Consumer Products Services (H.K.) Ltd., Taoyuan Branch

Lab Address: No. 47-2, 14th Ling, Chia Pau Vil., Lin Kou Dist., New Taipei City, Taiwan (R.O.C)

Test Location (1): No. 19, Hwa Ya 2nd Rd, Wen Hwa Tsuen, Kwei Shan Hsiang, Taoyuan Hsien 333, Taiwan, R.O.C.

Test Location (2): No.215, Sec. 3, Beixin Rd., Xindian Dist., New Taipei City 231, Taiwan, R.O.C



This report is for your exclusive use. Any copying or replication of this report to or for any other person or entity, or use of our name or trademark, is permitted only with our prior written permission. This report sets forth our findings solely with respect to the test samples identified herein. The results set forth in this report are not indicative or representative of the quality or characteristics of the lot from which a test sample was taken or any similar or identical product unless specifically and expressly noted. Our report includes all of the tests requested by you and the results thereof based upon the information that you provided to us. You have 60 days from date of issuance of this report to notify us of any material error or omission caused by our negligence, provided, however, that such notice shall be in writing and shall specifically address the issue you wish to raise. A failure to raise such issue within the prescribed time shall constitute your unqualified acceptance of the completeness of this report, the tests conducted and the correctness of the report contents. Unless specific mention, the uncertainty of measurement has been explicitly taken into account to declare the compliance or non-compliance to the specification. The report must not be used by the client to claim product certification, approval, or endorsement by TAF or any government agencies.

Table of Contents

| | |
|---|-----------|
| Release Control Record | 4 |
| 1 Certificate of Conformity | 5 |
| 2 Summary of Test Results..... | 6 |
| 2.1 Measurement Uncertainty..... | 6 |
| 2.2 Modification Record | 6 |
| 3 General Information | 7 |
| 3.1 General Description of EUT | 7 |
| 3.2 Description of Test Modes..... | 9 |
| 3.2.1 Test Mode Applicability and Tested Channel Detail..... | 11 |
| 3.3 Duty Cycle of Test Signal | 13 |
| 3.4 Description of Support Units | 14 |
| 3.4.1 Configuration of System under Test | 14 |
| 3.5 General Description of Applied Standards..... | 14 |
| 4 Test Types and Results | 15 |
| 4.1 Radiated Emission and Bandedge Measurement | 15 |
| 4.1.1 Limits of Radiated Emission and Bandedge Measurement | 15 |
| 4.1.2 Limits of Unwanted Emission Out of the Restricted Bands | 16 |
| 4.1.3 Test Instruments | 17 |
| 4.1.4 Test Procedures..... | 18 |
| 4.1.5 Deviation from Test Standard | 18 |
| 4.1.6 Test Set Up | 19 |
| 4.1.7 EUT Operating Conditions..... | 20 |
| 4.1.8 Test Results | 21 |
| 4.2 Conducted Emission Measurement..... | 63 |
| 4.2.1 Limits of Conducted Emission Measurement | 63 |
| 4.2.2 Test Instruments | 63 |
| 4.2.3 Test Procedures..... | 64 |
| 4.2.4 Deviation from Test Standard | 64 |
| 4.2.5 Test Setup..... | 64 |
| 4.2.6 EUT Operating Conditions..... | 64 |
| 4.2.7 Test Results | 65 |
| 4.3 Transmit Power Measurement..... | 67 |
| 4.3.1 Limits of Transmit Power Measurement | 67 |
| 4.3.2 Test Setup..... | 67 |
| 4.3.3 Test Instruments | 68 |
| 4.3.4 Test Procedure | 68 |
| 4.3.5 Deviation from Test Standard | 68 |
| 4.3.6 EUT Operating Conditions..... | 68 |
| 4.3.7 Test Result | 69 |
| 4.4 Peak Power Spectral Density Measurement | 74 |
| 4.4.1 Limits of Peak Power Spectral Density Measurement | 74 |
| 4.4.2 Test Setup..... | 74 |
| 4.4.3 Test Instruments | 74 |
| 4.4.4 Test Procedures..... | 74 |
| 4.4.5 Deviation from Test Standard | 75 |
| 4.4.6 EUT Operating Conditions..... | 75 |
| 4.4.7 Test Results | 76 |
| 4.5 Frequency Stability | 81 |
| 4.5.1 Limit of Frequency Stability Measurement | 81 |
| 4.5.2 Test Setup..... | 81 |
| 4.5.3 Test Instruments | 81 |
| 4.5.4 Test Procedure | 81 |
| 4.5.5 Deviation from Test Standard | 81 |

| | |
|---|-----------|
| 4.5.6 EUT Operating Condition | 81 |
| 4.5.7 Test Results | 82 |
| 4.6 6 dB Bandwidth Measurement..... | 83 |
| 4.6.1 Limits of 6 dB Bandwidth Measurement..... | 83 |
| 4.6.2 Test Setup..... | 83 |
| 4.6.3 Test Instruments | 83 |
| 4.6.4 Test Procedure | 83 |
| 4.6.5 Deviation from Test Standard | 83 |
| 4.6.6 EUT Operating Condition | 83 |
| 4.6.7 Test Results | 84 |
| 5 Pictures of Test Arrangements..... | 86 |
| Annex A- Radiated Out of Band Emisison (OOBE) Measurement (For U-NII-3 band) | 87 |
| Appendix – Information on the Testing Laboratories | 90 |

Release Control Record

| Issue No. | Description | Date Issued |
|---------------|------------------|---------------|
| RF170425C26-8 | Original Release | Aug. 08, 2017 |

1 Certificate of Conformity

Product: ASUS Phone

Brand: ASUS

Test Model: ASUS_Z01KD

Sample Status: Production Unit

Applicant: ASUSTek COMPUTER INC.

Test Date: May 27, 2017 ~ Jul. 06, 2017

Standards: 47 CFR FCC Part 15, Subpart E (Section 15.407)
ANSI C63.10:2013

The above equipment has been tested by **Bureau Veritas Consumer Products Services (H.K.) Ltd., Taoyuan Branch**, and found compliance with the requirement of the above standards. The test record, data evaluation & Equipment Under Test (EUT) configurations represented herein are true and accurate accounts of the measurements of the sample's EMC characteristics under the conditions specified in this report.

Prepared by :  , **Date:** Aug. 08, 2017
Ivonne Wu / Supervisor

Approved by :  , **Date:** Aug. 08, 2017
David Huang / Project Engineer

2 Summary of Test Results

| 47 CFR FCC Part 15, Subpart E (Section 15.407) | | | |
|--|--|--------|---|
| FCC Clause | Test Item | Result | Remarks |
| 15.407(b)(6) | AC Power Conducted Emissions | Pass | Meet the requirement of limit. Minimum passing margin is -19.10 dB at 0.15400 MHz. |
| 15.407(b) (1/2/3/4(i/ii)/6) | Radiated Emissions & Band Edge Measurement | Pass | Meet the requirement of limit. Minimum passing margin is -1.03 dB at 5470 MHz. |
| 15.407(a)(1/2/3) | Max Average Transmit Power | Pass | Meet the requirement of limit. |
| 15.407(a)(1/2/3) | Peak Power Spectral Density | Pass | Meet the requirement of limit. |
| 15.407(e) | 6 dB Bandwidth | Pass | Meet the requirement of limit. (U-NII-3 Band only) |
| 15.407(g) | Frequency Stability | Pass | Meet the requirement of limit. |
| 15.203 | Antenna Requirement | Pass | No antenna connector is used. |

*For U-NII-3 band compliance with rule part 15.407(b)(4)(i), the OOB test plots were recorded in Annex A.

2.1 Measurement Uncertainty

Where relevant, the following measurement uncertainty levels have been estimated for tests performed on the EUT as specified in CISPR 16-4-2:

| Measurement | Frequency | Expanded Uncertainty (k=2) (±) |
|------------------------------------|--------------------|--------------------------------|
| Conducted Emissions at mains ports | 150 kHz ~ 30 MHz | 2.44 dB |
| Radiated Emissions up to 1 GHz | 30 MHz ~ 200 MHz | 2.0153 dB |
| | 200 MHz ~ 1000 MHz | 2.0224 dB |
| Radiated Emissions above 1 GHz | 1 GHz ~ 18 GHz | 1.0121 dB |
| | 18 GHz ~ 40 GHz | 1.1508 dB |

2.2 Modification Record

There were no modifications required for compliance.

3 General Information

3.1 General Description of EUT

| | |
|------------------------------|---|
| Product | ASUS Phone |
| Brand | ASUS |
| Test Model | ASUS_Z01KD |
| SKU | BR/NA/SA-2CA US/BR/CO/PE/CL |
| Status of EUT | Production Unit |
| Power Supply Rating | 5.0 Vdc or 9 Vdc (adapter) 5.0 Vdc (host equipment) 3.85 Vdc (Li-ion battery) |
| Modulation Type | 256QAM, 64QAM, 16QAM, QPSK, BPSK |
| Modulation Technology | OFDM |
| Transfer Rate | 802.11a: 54.0/ 48.0/ 36.0/ 24.0/ 18.0/ 12.0/ 9.0/ 6.0 Mbps 802.11n: up to MCS7 802.11ac: up to V9 |
| Operating Frequency | 5180 ~ 5240 MHz, 5260 ~ 5320 MHz, 5500 ~ 5700 MHz, 5745 ~ 5825 MHz |
| Number of Channel | 5180 ~ 5240 MHz: 4 for 802.11a, 802.11n (HT20) 2 for 802.11n (HT40) 1 for 802.11ac (VHT80) 5260 ~ 5320 MHz: 4 for 802.11a, 802.11n (HT20) 2 for 802.11n (HT40) 1 for 802.11ac (VHT80) 5500 ~ 5700 MHz: 11 for 802.11a, 802.11n (HT20) 5 for 802.11n (HT40) 2 for 802.11ac (VHT80) 5745 ~ 5825 MHz: 5 for 802.11a, 802.11n (HT20) 2 for 802.11n (HT40) 1 for 802.11ac (VHT80) |
| Output Power | 53.211 mW for 5180 ~ 5240 MHz 54.702 mW for 5260 ~ 5320 MHz 54.450 mW for 5500 ~ 5700 MHz 54.325 mW for 5745 ~ 5825 MHz |
| Antenna Type | PIFA antenna with -0.03 dBi gain (5180 ~ 5240 MHz) PIFA antenna with 1.42 dBi gain (5260 ~ 5320 MHz) PIFA antenna with 1.08 dBi gain (5500 ~ 5700 MHz) PIFA antenna with -0.62 dBi gain (5745 ~ 5825 MHz) |
| Antenna Connector | N/A |
| Accessory Device | Refer to Note as below |
| Data Cable Supplied | Refer to Note as below |

Note:

1. The EUT provides one transmitter and receiver.

| Modulation Mode | Tx Function |
|------------------------|--------------------|
| 802.11a | 1TX |
| 802.11n (HT20) | 1TX |
| 802.11n (HT40) | 1TX |
| 802.11ac (HT20) | 1TX |
| 802.11ac (HT40) | 1TX |
| 802.11ac (VHT80) | 1TX |

* The modulation and bandwidth are similar for 802.11n mode for HT20 / HT40 and 802.11ac mode for HT20 / HT40, therefore investigated worst case to representative mode in test report. (Final test mode refer section 3.2.1)

2. The EUT's accessories list refers to Ext. Pho.
3. The above EUT information is declared by manufacturer and for more detailed features description, please refer to the manufacturer's specifications or user's manual.

3.2 Description of Test Modes

For 5180 ~ 5240 MHz

4 channels are provided for 802.11a, 802.11n (HT20):

| Channel | Frequency (MHz) | Channel | Frequency (MHz) |
|---------|-----------------|---------|-----------------|
| 36 | 5180 | 44 | 5220 |
| 40 | 5200 | 48 | 5240 |

2 channels are provided for 802.11n (HT40):

| Channel | Frequency (MHz) | Channel | Frequency (MHz) |
|---------|-----------------|---------|-----------------|
| 38 | 5190 | 46 | 5230 |

1 channel is provided for 802.11ac (VHT80):

| Channel | Frequency (MHz) |
|---------|-----------------|
| 42 | 5210 |

For 5260 ~ 5320 MHz

4 channels are provided for 802.11a, 802.11n (HT20):

| Channel | Frequency (MHz) | Channel | Frequency (MHz) |
|---------|-----------------|---------|-----------------|
| 52 | 5260 | 60 | 5300 |
| 56 | 5280 | 64 | 5320 |

2 channels are provided for 802.11n (HT40):

| Channel | Frequency (MHz) | Channel | Frequency (MHz) |
|---------|-----------------|---------|-----------------|
| 54 | 5270 | 62 | 5310 |

1 channel is provided for 802.11ac (VHT80):

| Channel | Frequency (MHz) |
|---------|-----------------|
| 58 | 5290 |

For 5500 ~ 5700 MHz

11 channels are provided for 802.11a, 802.11n (HT20):

| Channel | Frequency (MHz) | Channel | Frequency (MHz) |
|---------|-----------------|---------|-----------------|
| 100 | 5500 | 124 | 5620 |
| 104 | 5520 | 128 | 5640 |
| 108 | 5540 | 132 | 5660 |
| 112 | 5560 | 136 | 5680 |
| 116 | 5580 | 140 | 5700 |
| 120 | 5600 | | |

5 channels are provided for 802.11n (HT40):

| Channel | Frequency (MHz) | Channel | Frequency (MHz) |
|---------|-----------------|---------|-----------------|
| 102 | 5510 | 126 | 5630 |
| 110 | 5550 | 134 | 5670 |
| 118 | 5590 | | |

2 channels are provided for 802.11ac (VHT80):

| Channel | Frequency (MHz) | Channel | Frequency (MHz) |
|---------|-----------------|---------|-----------------|
| 106 | 5530 | 122 | 5610 |

For 5745 ~ 5825 MHz:

5 channels are provided for 802.11a, 802.11n (HT20):

| Channel | Frequency (MHz) | Channel | Frequency (MHz) |
|---------|-----------------|---------|-----------------|
| 149 | 5745 | 161 | 5805 |
| 153 | 5765 | 165 | 5825 |
| 157 | 5785 | | |

2 channels are provided for 802.11n (HT40):

| Channel | Frequency (MHz) | Channel | Frequency (MHz) |
|---------|-----------------|---------|-----------------|
| 151 | 5755 | 159 | 5795 |

1 channel is provided for 802.11ac (VHT80):

| Channel | Frequency (MHz) |
|---------|-----------------|
| 155 | 5775 |

3.2.1 Test Mode Applicability and Tested Channel Detail

| EUT Configure Mode | Applicable To | | | | Description |
|--------------------|---------------|-----------|-----|------|-------------|
| | RE \geq 1G | RE $<$ 1G | PLC | APCM | |
| - | √ | √ | √ | √ | - |

Where **RE \geq 1G**: Radiated Emission above 1 GHz **RE $<$ 1G**: Radiated Emission below 1 GHz
PLC: Power Line Conducted Emission **APCM**: Antenna Port Conducted Measurement

Note:

1. The EUT had been pre-tested on the positioned of each 3 axis. The worst case was found when positioned on **Y-plane**.
2. "-" means no effect.

Radiated Emission Test (Above 1 GHz):

- Pre-Scan has been conducted to determine the worst-case mode from all possible combinations between available modulations, data rates and antenna ports (if EUT with antenna diversity architecture).
- Following channel(s) was (were) selected for the final test as listed below.

| EUT Configure Mode | Frequency Band (MHz) | Mode | Available Channel | Tested Channel | Modulation Technology | Modulation Type | Data Rate (Mbps) |
|--------------------|----------------------|------------------|-------------------|----------------|-----------------------|-----------------|------------------|
| - | 5180-5240 | 802.11a | 36 to 48 | 36, 44, 48 | OFDM | BPSK | 6.0 |
| - | | 802.11n (HT20) | 36 to 48 | 36, 44, 48 | OFDM | BPSK | MCS0 |
| - | | 802.11n (HT40) | 38 to 46 | 38, 46 | OFDM | BPSK | MCS0 |
| - | | 802.11ac (VHT80) | 42 | 42 | OFDM | BPSK | MCS0 |
| - | 5260-5320 | 802.11a | 52 to 64 | 52, 60, 64 | OFDM | BPSK | 6.0 |
| - | | 802.11n (HT20) | 52 to 64 | 52, 60, 64 | OFDM | BPSK | MCS0 |
| - | | 802.11n (HT40) | 54 to 62 | 54, 62 | OFDM | BPSK | MCS0 |
| - | | 802.11ac (VHT80) | 58 | 58 | OFDM | BPSK | MCS0 |
| - | 5500-5700 | 802.11a | 100 to 140 | 100, 116, 140 | OFDM | BPSK | 6.0 |
| - | | 802.11n (HT20) | 100 to 140 | 100, 116, 140 | OFDM | BPSK | MCS0 |
| - | | 802.11n (HT40) | 102 to 134 | 102, 110, 134 | OFDM | BPSK | MCS0 |
| - | | 802.11ac (VHT80) | 106 to 122 | 106, 122 | OFDM | BPSK | MCS0 |
| - | 5745-5825 | 802.11a | 149 to 165 | 149, 157, 165 | OFDM | BPSK | 6.0 |
| - | | 802.11n (HT20) | 149 to 165 | 149, 157, 165 | OFDM | BPSK | MCS0 |
| - | | 802.11n (HT40) | 151 to 159 | 151, 159 | OFDM | BPSK | MCS0 |
| - | | 802.11ac (VHT80) | 155 | 155 | OFDM | BPSK | MCS0 |

Radiated Emission Test (Below 1 GHz):

- Pre-Scan has been conducted to determine the worst-case mode from all possible combinations between available modulations, data rates and antenna ports (if EUT with antenna diversity architecture).
- Following channel(s) was (were) selected for the final test as listed below.

| EUT Configure Mode | Frequency Band (MHz) | Mode | Available Channel | Tested Channel | Modulation Technology | Modulation Type | Data Rate (Mbps) |
|--------------------|----------------------|------------------|-------------------|----------------|-----------------------|-----------------|------------------|
| - | 5180-5240 | 802.11ac (VHT80) | 42 | 42 | OFDM | BPSK | MCS0 |
| - | 5260-5320 | 802.11ac (VHT80) | 58 | 58 | OFDM | BPSK | MCS0 |
| - | 5500-5700 | 802.11ac (VHT80) | 106 to 122 | 106 | OFDM | BPSK | MCS0 |
| - | 5745-5825 | 802.11a | 155 | 165 | OFDM | BPSK | 6.0 |

Power Line Conducted Emission Test:

- Pre-Scan has been conducted to determine the worst-case mode from all possible combinations between available modulations, data rates and antenna ports (if EUT with antenna diversity architecture).

Following channel(s) was (were) selected for the final test as listed below.

| EUT Configure Mode | Frequency Band (MHz) | Mode | Available Channel | Tested Channel | Modulation Technology | Modulation Type | Data Rate (Mbps) |
|--------------------|----------------------|------------------|-------------------|----------------|-----------------------|-----------------|------------------|
| - | 5500-5700 | 802.11ac (VHT80) | 106 to 122 | 106 | OFDM | BPSK | 6.0 |

Antenna Port Conducted Measurement:

This item includes all test value of each mode, but only includes spectrum plot of worst value of each mode.

Pre-Scan has been conducted to determine the worst-case mode from all possible combinations between available modulations, data rates and antenna ports (if EUT with antenna diversity architecture).

Following channel(s) was (were) selected for the final test as listed below.

| EUT Configure Mode | Frequency Band (MHz) | Mode | Available Channel | Tested Channel | Modulation Technology | Modulation Type | Data Rate (Mbps) |
|--------------------|----------------------|------------------|-------------------|----------------|-----------------------|-----------------|------------------|
| - | 5180-5240 | 802.11a | 36 to 48 | 36, 44, 48 | OFDM | BPSK | 6.0 |
| - | | 802.11n (HT20) | 36 to 48 | 36, 44, 48 | OFDM | BPSK | MCS0 |
| - | | 802.11n (HT40) | 38 to 46 | 38, 46 | OFDM | BPSK | MCS0 |
| - | | 802.11ac (VHT80) | 42 | 42 | OFDM | BPSK | MCS0 |
| - | 5260-5320 | 802.11a | 52 to 64 | 52, 60, 64 | OFDM | BPSK | 6.0 |
| - | | 802.11n (HT20) | 52 to 64 | 52, 60, 64 | OFDM | BPSK | MCS0 |
| - | | 802.11n (HT40) | 54 to 62 | 54, 62 | OFDM | BPSK | MCS0 |
| - | | 802.11ac (VHT80) | 58 | 58 | OFDM | BPSK | MCS0 |
| - | 5500-5700 | 802.11a | 100 to 140 | 100, 116, 140 | OFDM | BPSK | 6.0 |
| - | | 802.11n (HT20) | 100 to 140 | 100, 116, 140 | OFDM | BPSK | MCS0 |
| - | | 802.11n (HT40) | 102 to 134 | 102, 110, 134 | OFDM | BPSK | MCS0 |
| - | | 802.11ac (VHT80) | 106 to 122 | 106, 122 | OFDM | BPSK | MCS0 |
| - | 5745-5825 | 802.11a | 149 to 165 | 149, 157, 165 | OFDM | BPSK | 6.0 |
| - | | 802.11n (HT20) | 149 to 165 | 149, 157, 165 | OFDM | BPSK | MCS0 |
| - | | 802.11n (HT40) | 151 to 159 | 151, 159 | OFDM | BPSK | MCS0 |
| - | | 802.11ac (VHT80) | 155 | 155 | OFDM | BPSK | MCS0 |

Test Condition:

| Applicable To | Environmental Conditions | Input Power | Tested by |
|---------------|--------------------------|----------------|---------------|
| RE \geq 1G | 25 deg. C, 65 % RH | 120 Vac, 60 Hz | Charles Hsiao |
| RE $<$ 1G | 25 deg. C, 65 % RH | 120 Vac, 60 Hz | Charles Hsiao |
| PLC | 25 deg. C, 65 % RH | 120 Vac, 60 Hz | Getaz Yang |
| APCM | 25 deg. C, 65 % RH | 3.85 Vdc | Anson Lin |

3.3 Duty Cycle of Test Signal

MODULATION TYPE: BPSK

802.11a: Duty cycle = $2.063/2.189 = 0.942$, Duty factor = $10 * \log(1/0.942) = 0.26$

802.11n (HT20): Duty cycle = $1.923/2.052 = 0.937$, Duty factor = $10 * \log(1/0.937) = 0.28$

802.11n (HT40): Duty cycle = $946/1086 = 0.871$, Duty factor = $10 * \log(1/0.871) = 0.60$

802.11ac (VHT80): Duty cycle = $461/591 = 0.780$, Duty factor = $10 * \log(1/0.780) = 1.08$

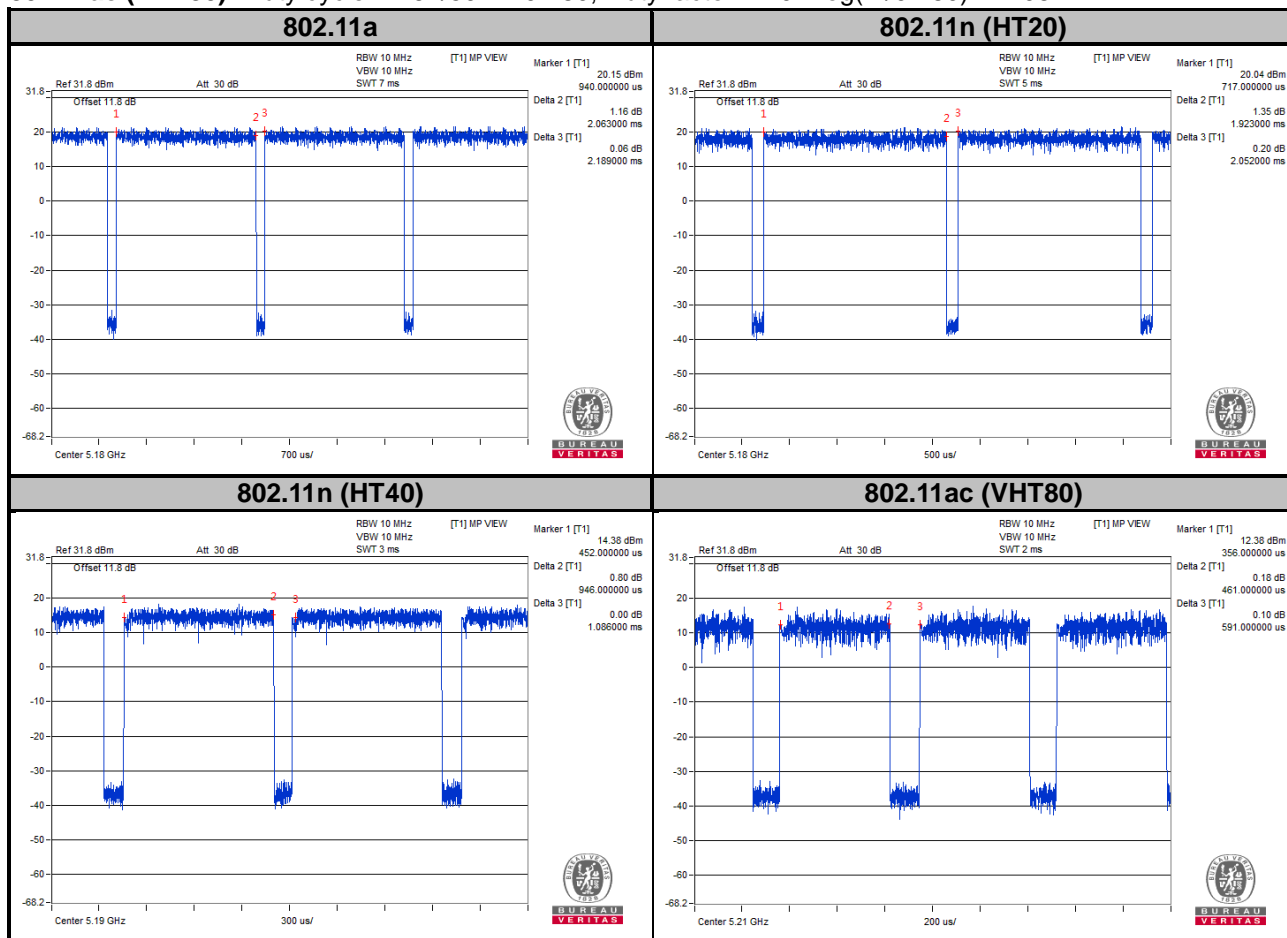

3.4 Description of Support Units

The EUT has been tested as an independent unit together with other necessary accessories or support units.

3.4.1 Configuration of System under Test

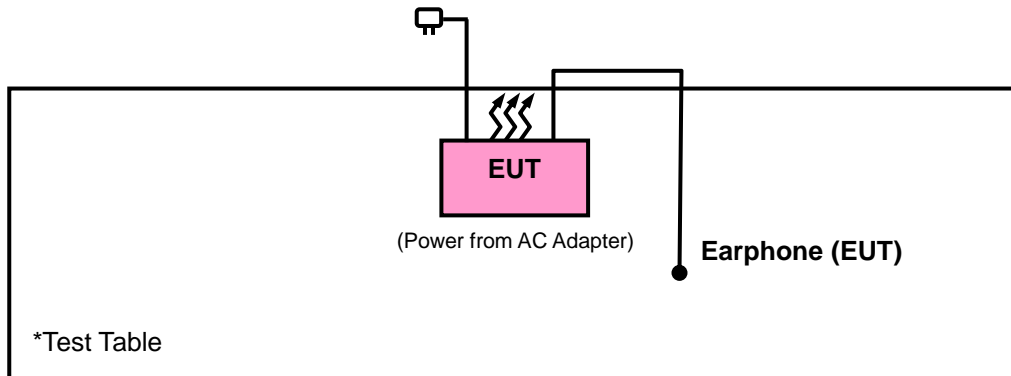

3.5 General Description of Applied Standards

The EUT is a RF Product. According to the specifications of the manufacturer, it must comply with the requirements of the following standards:

FCC Part 15, Subpart E (15.407)

789033 D02 General UNII Test Procedures New Rules v01r04

644545 D01 Guidance for IEEE 802 11ac v01r02

ANSI C63.10-2013

All test items have been performed and recorded as per the above standards.

Note: The EUT has been verified to comply with the requirements of FCC Part 15, Subpart B, Class B (DoC). The test report has been issued separately.

4 Test Types and Results

4.1 Radiated Emission and Bandedge Measurement

4.1.1 Limits of Radiated Emission and Bandedge Measurement

Radiated emissions which fall in the restricted bands must comply with the radiated emission limits specified as below table. Other emissions shall be at least 20 dB below the highest level of the desired power:

| Frequencies (MHz) | Field Strength (microvolts/meter) | Measurement Distance (meters) |
|-------------------|-----------------------------------|-------------------------------|
| 0.009 ~ 0.490 | 2400/F (kHz) | 300 |
| 0.490 ~ 1.705 | 24000/F (kHz) | 30 |
| 1.705 ~ 30.0 | 30 | 30 |
| 30 ~ 88 | 100 | 3 |
| 88 ~ 216 | 150 | 3 |
| 216 ~ 960 | 200 | 3 |
| Above 960 | 500 | 3 |

Note:

1. The lower limit shall apply at the transition frequencies.
2. Emission level (dBuV/m) = 20 log Emission level (uV/m).
3. For frequencies above 1000 MHz, the field strength limits are based on average detector, however, the peak field strength of any emission shall not exceed the maximum permitted average limits, specified above by more than 20 dB under any condition of modulation.

4.1.2 Limits of Unwanted Emission Out of the Restricted Bands

| Applicable To | | Limit | |
|---|------------------|---|---|
| 789033 D02 General UNII Test Procedures New Rules v01r04 | | Field Strength at 3 m | |
| | | PK: 74 (dBµV/m) | AV: 54 (dBµV/m) |
| Frequency Band | Applicable To | EIRP Limit | Equivalent Field Strength at 3 m |
| 5150~5250 MHz | 15.407(b)(1) | PK: -27 (dBm/MHz) | PK: 68.2 (dBµV/m) |
| 5250~5350 MHz | 15.407(b)(2) | | |
| 5470~5725 MHz | 15.407(b)(3) | | |
| 5725~5850 MHz | 15.407(b)(4)(i) | PK:-27 (dBm/MHz) ^{*1} PK:10 (dBm/MHz) ^{*2} PK:15.6 (dBm/MHz) ^{*3} PK:27 (dBm/MHz) ^{*4} | PK: 68.2 (dBµV/m) ^{*1} PK:105.2 (dBµV/m) ^{*2} PK: 110.8 (dBµV/m) ^{*3} PK:122.2 (dBµV/m) ^{*4} |
| | 15.407(b)(4)(ii) | Emission limits in section 15.247(d) | |

^{*1} beyond 75 MHz or more above of the band edge.

^{*2} below the band edge increasing linearly to 10 dBm/MHz at 25 MHz above.

^{*3} below the band edge increasing linearly to a level of 15.6 dBm/MHz at 5 MHz above.

^{*4} from 5 MHz above or below the band edge increasing linearly to a level of 27 dBm/MHz at the band edge.

Note:

The following formula is used to convert the equipment isotropic radiated power (eirp) to field strength:

$$E = \frac{1000000\sqrt{30P}}{3} \mu\text{V/m, where } P \text{ is the eirp (Watts).}$$

4.1.3 Test Instruments

<Test Date: May 27, 2017 ~ Jun. 02, 2017>

| Description & Manufacturer | Model No. | Serial No. | Date of Calibration | Due Date of Calibration |
|--|-----------------|---|---------------------|-------------------------|
| Test Receiver Agilent Technologies | N9010A | MY52220314 | Nov. 16, 2016 | Nov. 15, 2017 |
| Spectrum Analyzer ROHDE & SCHWARZ | FSU43 | 101261 | Dec. 13, 2016 | Dec. 12, 2017 |
| BILOG Antenna SCHWARZBECK | VULB9168 | 9168-472 | Dec. 16, 2016 | Dec. 15, 2017 |
| HORN Antenna ETS-Lindgren | 3117 | 00143293 | Dec. 29, 2016 | Dec. 28, 2017 |
| HORN Antenna SCHWARZBECK | BBHA 9170 | 9170-480 | Dec. 14, 2016 | Dec. 13, 2017 |
| Fixed Attenuator Mini-Circuits | BW-N10W5+ | NA | Jul. 08, 2016 | Jul. 07, 2017 |
| Bluetooth Tester | CBT | 100946 | Jul. 29, 2016 | Jul. 28, 2018 |
| Loop Antenna | EM-6879 | 269 | Aug. 11, 2016 | Aug. 10, 2017 |
| Preamplifier Agilent | 310N | 187226 | Jun. 24, 2016 | Jun. 23, 2017 |
| Preamplifier Agilent | 83017A | MY39501357 | Jun. 24, 2016 | Jun. 23, 2017 |
| Power Meter Anritsu | ML2495A | 1232002 | Sep. 08, 2016 | Sep. 07, 2017 |
| Power Sensor Anritsu | MA2411B | 1207325 | Sep. 08, 2016 | Sep. 07, 2017 |
| RF signal cable ETS-LINDGREN | 5D-FB | Cable-CH1-01(R FC-SMS-100-SM S-120+RFC-SMS -100-SMS-400) | Jun. 24, 2016 | Jun. 23, 2017 |
| RF signal cable ETS-LINDGREN | 8D-FB | Cable-CH1-02(R FC-SMS-100-SM S-24) | Jun. 24, 2016 | Jun. 23, 2017 |
| Software BV ADT | E3 8.130425b | NA | NA | NA |
| Antenna Tower MF | NA | NA | NA | NA |
| Turn Table MF | NA | NA | NA | NA |
| Antenna Tower & Turn Table Controller MF | MF-7802 | NA | NA | NA |

- Note: 1. The calibration interval of the above test instruments is 12 / 24 months and the calibrations are traceable to NML/ROC and NIST/USA.
2. The test was performed in HsinTien Chamber 1.
3. The horn antenna and preamplifier (model: 83017A) are used only for the measurement of emission frequency above 1 GHz if tested.
4. The IC Site Registration No. is IC7450I-1.

4.1.4 Test Procedures

- a. The EUT was placed on the top of a rotating table 0.8 meters (for below 1 GHz) / 1.5 meters (for above 1 GHz) above the ground at 3 meter chamber room for test. The table was rotated 360 degrees to determine the position of the highest radiation.
- b. The EUT was set 3 meters away from the interference-receiving antenna, which was mounted on the top of a variable-height antenna tower.
- c. The height of antenna is varied from one meter to four meters above the ground to determine the maximum value of the field strength. Both horizontal and vertical polarizations of the antenna are set to make the measurement.
- d. For each suspected emission, the EUT was arranged to its worst case and then the antenna was tuned to heights from 1 meter to 4 meters and the rotatable table was turned from 0 degrees to 360 degrees to find the maximum reading.
- e. The test-receiver system was set to quasi-peak detect function and specified bandwidth with maximum hold mode when the test frequency is below 1 GHz.
- f. The test-receiver system was set to peak and average detected function and specified bandwidth with maximum hold mode when the test frequency is above 1 GHz. If the peak reading value also meets average limit, measurement with the average detector is unnecessary.

Note:

1. The resolution bandwidth and video bandwidth of test receiver/spectrum analyzer is 120 kHz & 360 kHz for Quasi-peak detection (QP) at frequency below 1 GHz.
2. The resolution bandwidth of test receiver/spectrum analyzer is 1 MHz and the video bandwidth is 3 MHz for Peak detection (PK) at frequency above 1 GHz.
3. The resolution bandwidth of test receiver/spectrum analyzer is 1 MHz and the video bandwidth is 1/T for Average (Duty cycle < 98 %) detection at frequency above 1 GHz.
4. The resolution bandwidth of test receiver/spectrum analyzer is 1 MHz and the video bandwidth is 10 Hz (Duty cycle ≥ 98 %) for Average detection (AV) at frequency above 1 GHz.
5. All modes of operation were investigated and the worst-case emissions are reported.

4.1.5 Deviation from Test Standard

No deviation.

4.1.6 Test Set Up

<Radiated emission below 30MHz>

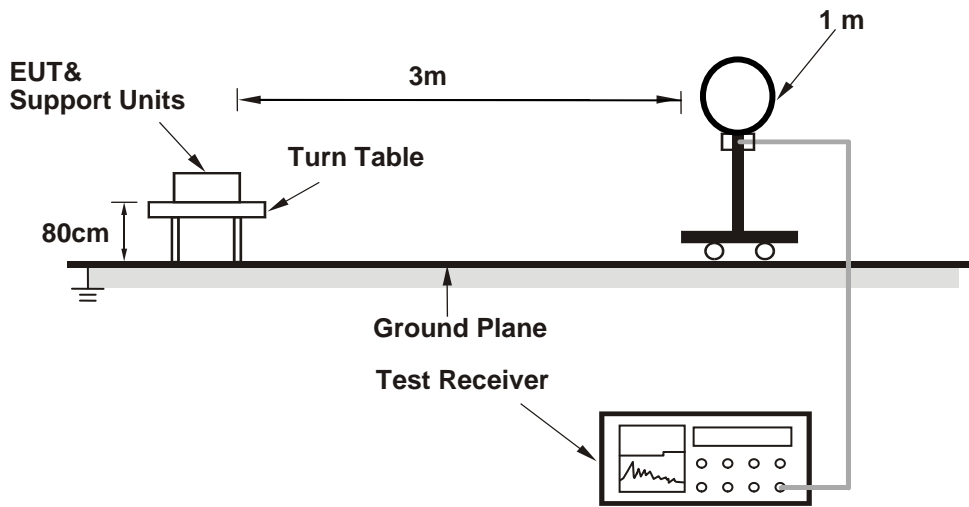

<Frequency Range below 1 GHz>

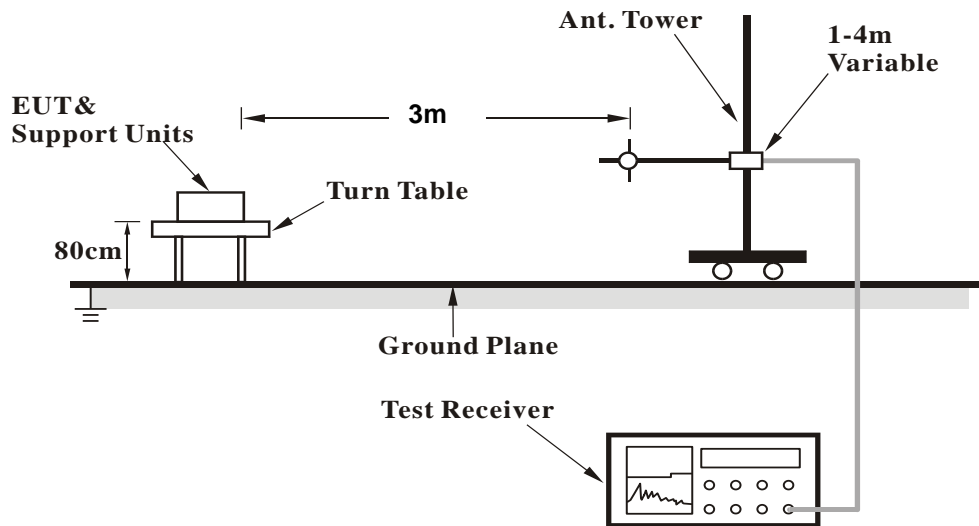

<Frequency Range above 1 GHz>

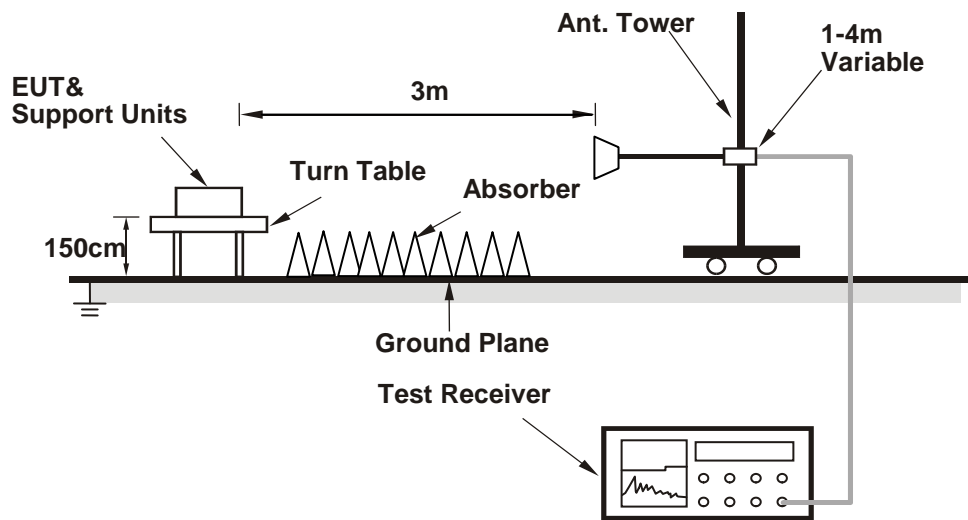

For the actual test configuration, please refer to the attached file (Test Setup Photo).

4.1.7 EUT Operating Conditions

- Placed the EUT on a testing table.
- Use the software to control the EUT under transmission condition continuously at specific channel frequency.

4.1.8 Test Results
 Above 1 GHz Data :
 802.11a

| EUT Test Condition | | Measurement Detail | |
|--------------------------|--------------------|--------------------|---------------------------|
| Channel | Channel 36 | Frequency Range | 1 GHz ~ 40 GHz |
| Input Power | 120 Vac, 60 Hz | Detector Function | Peak (PK) Average (AV) |
| Environmental Conditions | 25 deg. C, 65 % RH | Tested By | Charles Hsiao |

| Antenna Polarity & Test Distance: Horizontal at 3 m | | | | | | | | | | |
|---|-------------------------|-------------------|----------------|-------------|-----------------------|-----------------|--------------------|---------------------|----------------------|---------|
| Frequency (MHz) | Emission Level (dBuV/m) | Read Level (dBuV) | Limit (dBuV/m) | Margin (dB) | Antenna Factor (dB/m) | Cable Loss (dB) | Preamp Factor (dB) | Antenna Height (cm) | Table Angle (Degree) | Remark |
| 5139.95 | 55.98 | 47.72 | 74 | -18.02 | 34.12 | 8.13 | 33.99 | 235 | 69 | Peak |
| 5149.85 | 44.58 | 36.33 | 54 | -9.42 | 34.12 | 8.13 | 34 | 235 | 69 | Average |
| 5180 | 99.31 | 91 | | | 34.15 | 8.16 | 34 | 235 | 69 | Average |
| 5180 | 106.11 | 97.8 | | | 34.15 | 8.16 | 34 | 235 | 69 | Peak |
| 10360 | 46.35 | 32.05 | 54 | -7.65 | 37.12 | 12.3 | 35.12 | 177 | 4 | Average |
| 10360 | 55.63 | 41.33 | 74 | -18.37 | 37.12 | 12.3 | 35.12 | 177 | 4 | Peak |

| Antenna Polarity & Test Distance: Vertical at 3 m | | | | | | | | | | |
|---|-------------------------|-------------------|----------------|-------------|-----------------------|-----------------|--------------------|---------------------|----------------------|---------|
| Frequency (MHz) | Emission Level (dBuV/m) | Read Level (dBuV) | Limit (dBuV/m) | Margin (dB) | Antenna Factor (dB/m) | Cable Loss (dB) | Preamp Factor (dB) | Antenna Height (cm) | Table Angle (Degree) | Remark |
| 5105.6 | 53.37 | 45.2 | 74 | -20.63 | 34.09 | 8.07 | 33.99 | 106 | 96 | Peak |
| 5149.7 | 43.64 | 35.39 | 54 | -10.36 | 34.12 | 8.13 | 34 | 106 | 96 | Average |
| 5180 | 95.66 | 87.35 | | | 34.15 | 8.16 | 34 | 106 | 96 | Average |
| 5180 | 102.89 | 94.58 | | | 34.15 | 8.16 | 34 | 106 | 96 | Peak |
| 10360 | 45.89 | 31.59 | 54 | -8.11 | 37.12 | 12.3 | 35.12 | 155 | 24 | Average |
| 10360 | 55.11 | 40.81 | 74 | -18.89 | 37.12 | 12.3 | 35.12 | 155 | 24 | Peak |

Remarks:

- Emission Level = Read Level + Antenna Factor + Cable Loss - Preamp Factor
 Margin value = Emission level – Limit value
- 5180 MHz: Fundamental Frequency

| EUT Test Condition | | Measurement Detail | |
|--------------------------|--------------------|--------------------|---------------------------|
| Channel | Channel 44 | Frequency Range | 1 GHz ~ 40 GHz |
| Input Power | 120 Vac, 60 Hz | Detector Function | Peak (PK) Average (AV) |
| Environmental Conditions | 25 deg. C, 65 % RH | Tested By | Charles Hsiao |

| Antenna Polarity & Test Distance: Horizontal at 3 m | | | | | | | | | | |
|---|-------------------------|-------------------|----------------|-------------|-----------------------|-----------------|--------------------|---------------------|----------------------|---------|
| Frequency (MHz) | Emission Level (dBuV/m) | Read Level (dBuV) | Limit (dBuV/m) | Margin (dB) | Antenna Factor (dB/m) | Cable Loss (dB) | Preamp Factor (dB) | Antenna Height (cm) | Table Angle (Degree) | Remark |
| 5138.3 | 53.85 | 45.6 | 74 | -20.15 | 34.11 | 8.13 | 33.99 | 235 | 69 | Peak |
| 5148.65 | 43.21 | 34.96 | 54 | -10.79 | 34.12 | 8.13 | 34 | 235 | 69 | Average |
| 5220 | 99.74 | 91.35 | | | 34.17 | 8.22 | 34 | 235 | 69 | Average |
| 5220 | 106.12 | 97.73 | | | 34.17 | 8.22 | 34 | 235 | 69 | Peak |
| 5413.14 | 54.19 | 45.46 | 74 | -19.81 | 34.33 | 8.44 | 34.04 | 235 | 69 | Peak |
| 5435.91 | 43.3 | 34.51 | 54 | -10.7 | 34.35 | 8.48 | 34.04 | 235 | 69 | Average |

| Antenna Polarity & Test Distance: Vertical at 3 m | | | | | | | | | | |
|---|-------------------------|-------------------|----------------|-------------|-----------------------|-----------------|--------------------|---------------------|----------------------|---------|
| Frequency (MHz) | Emission Level (dBuV/m) | Read Level (dBuV) | Limit (dBuV/m) | Margin (dB) | Antenna Factor (dB/m) | Cable Loss (dB) | Preamp Factor (dB) | Antenna Height (cm) | Table Angle (Degree) | Remark |
| 5073.65 | 53.53 | 45.41 | 74 | -20.47 | 34.07 | 8.03 | 33.98 | 106 | 96 | Peak |
| 5088.8 | 42.88 | 34.71 | 54 | -11.12 | 34.08 | 8.07 | 33.98 | 106 | 96 | Average |
| 5220 | 95.8 | 87.41 | | | 34.17 | 8.22 | 34 | 106 | 96 | Average |
| 5220 | 102.78 | 94.39 | | | 34.17 | 8.22 | 34 | 106 | 96 | Peak |
| 5355.28 | 53.47 | 44.84 | 74 | -20.53 | 34.28 | 8.38 | 34.03 | 106 | 96 | Peak |
| 5401.92 | 43.16 | 34.44 | 54 | -10.84 | 34.32 | 8.44 | 34.04 | 106 | 96 | Average |

Remarks:

- Emission Level = Read Level + Antenna Factor + Cable Loss - Preamp Factor
Margin value = Emission level – Limit value
- 5220 MHz: Fundamental Frequency

| EUT Test Condition | | Measurement Detail | |
|--------------------------|--------------------|--------------------|---------------------------|
| Channel | Channel 48 | Frequency Range | 1 GHz ~ 40 GHz |
| Input Power | 120 Vac, 60 Hz | Detector Function | Peak (PK) Average (AV) |
| Environmental Conditions | 25 deg. C, 65 % RH | Tested By | Charles Hsiao |

| Antenna Polarity & Test Distance: Horizontal at 3 m | | | | | | | | | | |
|---|-------------------------|-------------------|----------------|-------------|-----------------------|-----------------|--------------------|---------------------|----------------------|---------|
| Frequency (MHz) | Emission Level (dBuV/m) | Read Level (dBuV) | Limit (dBuV/m) | Margin (dB) | Antenna Factor (dB/m) | Cable Loss (dB) | Preamp Factor (dB) | Antenna Height (cm) | Table Angle (Degree) | Remark |
| 5240 | 99.14 | 90.7 | | | 34.19 | 8.26 | 34.01 | 235 | 69 | Average |
| 5240 | 106.94 | 98.5 | | | 34.19 | 8.26 | 34.01 | 235 | 69 | Peak |
| 5426.01 | 43.45 | 34.68 | 54 | -10.55 | 34.33 | 8.48 | 34.04 | 235 | 69 | Average |
| 5445.15 | 53.84 | 45.02 | 74 | -20.16 | 34.35 | 8.51 | 34.04 | 235 | 69 | Peak |
| 10480 | 46.38 | 31.87 | 54 | -7.62 | 37.19 | 12.53 | 35.21 | 105 | 114 | Average |
| 10480 | 55.7 | 41.19 | 74 | -18.3 | 37.19 | 12.53 | 35.21 | 105 | 114 | Peak |

| Antenna Polarity & Test Distance: Vertical at 3 m | | | | | | | | | | |
|---|-------------------------|-------------------|----------------|-------------|-----------------------|-----------------|--------------------|---------------------|----------------------|---------|
| Frequency (MHz) | Emission Level (dBuV/m) | Read Level (dBuV) | Limit (dBuV/m) | Margin (dB) | Antenna Factor (dB/m) | Cable Loss (dB) | Preamp Factor (dB) | Antenna Height (cm) | Table Angle (Degree) | Remark |
| 5240 | 95.77 | 87.33 | | | 34.19 | 8.26 | 34.01 | 106 | 96 | Average |
| 5240 | 102.5 | 94.06 | | | 34.19 | 8.26 | 34.01 | 106 | 96 | Peak |
| 5378.6 | 43.13 | 34.45 | 54 | -10.87 | 34.31 | 8.41 | 34.04 | 106 | 96 | Average |
| 5427.88 | 53.96 | 45.19 | 74 | -20.04 | 34.33 | 8.48 | 34.04 | 106 | 96 | Peak |
| 10480 | 46.86 | 32.35 | 54 | -7.14 | 37.19 | 12.53 | 35.21 | 119 | 346 | Average |
| 10480 | 55.9 | 41.39 | 74 | -18.1 | 37.19 | 12.53 | 35.21 | 119 | 346 | Peak |

Remarks:

- Emission Level = Read Level + Antenna Factor + Cable Loss - Preamp Factor
Margin value = Emission level – Limit value
- 5240 MHz: Fundamental Frequency

| EUT Test Condition | | Measurement Detail | |
|--------------------------|--------------------|--------------------|---------------------------|
| Channel | Channel 52 | Frequency Range | 1 GHz ~ 40 GHz |
| Input Power | 120 Vac, 60 Hz | Detector Function | Peak (PK) Average (AV) |
| Environmental Conditions | 25 deg. C, 65 % RH | Tested By | Charles Hsiao |

| Antenna Polarity & Test Distance: Horizontal at 3 m | | | | | | | | | | |
|---|-------------------------|-------------------|----------------|-------------|-----------------------|-----------------|--------------------|---------------------|----------------------|---------|
| Frequency (MHz) | Emission Level (dBuV/m) | Read Level (dBuV) | Limit (dBuV/m) | Margin (dB) | Antenna Factor (dB/m) | Cable Loss (dB) | Preamp Factor (dB) | Antenna Height (cm) | Table Angle (Degree) | Remark |
| 5035.4 | 53.41 | 45.35 | 74 | -20.59 | 34.03 | 8 | 33.97 | 198 | 304 | Peak |
| 5078 | 42.91 | 34.79 | 54 | -11.09 | 34.07 | 8.03 | 33.98 | 198 | 304 | Average |
| 5260 | 100 | 91.54 | | | 34.21 | 8.26 | 34.01 | 198 | 304 | Average |
| 5260 | 108.41 | 99.95 | | | 34.21 | 8.26 | 34.01 | 198 | 304 | Peak |
| 10520 | 50.12 | 35.53 | 54 | -3.88 | 37.21 | 12.61 | 35.23 | 116 | 145 | Average |
| 10520 | 58.65 | 44.06 | 74 | -15.35 | 37.21 | 12.61 | 35.23 | 116 | 145 | Peak |

| Antenna Polarity & Test Distance: Vertical at 3 m | | | | | | | | | | |
|---|-------------------------|-------------------|----------------|-------------|-----------------------|-----------------|--------------------|---------------------|----------------------|---------|
| Frequency (MHz) | Emission Level (dBuV/m) | Read Level (dBuV) | Limit (dBuV/m) | Margin (dB) | Antenna Factor (dB/m) | Cable Loss (dB) | Preamp Factor (dB) | Antenna Height (cm) | Table Angle (Degree) | Remark |
| 5105.45 | 53.7 | 45.54 | 74 | -20.3 | 34.08 | 8.07 | 33.99 | 123 | 289 | Peak |
| 5119.1 | 42.84 | 34.64 | 54 | -11.16 | 34.09 | 8.1 | 33.99 | 123 | 289 | Average |
| 5260 | 96.25 | 87.79 | | | 34.21 | 8.26 | 34.01 | 123 | 289 | Average |
| 5260 | 103.42 | 94.96 | | | 34.21 | 8.26 | 34.01 | 123 | 289 | Peak |
| 10520 | 47.83 | 33.24 | 54 | -6.17 | 37.21 | 12.61 | 35.23 | 104 | 157 | Average |
| 10520 | 56.98 | 42.39 | 74 | -17.02 | 37.21 | 12.61 | 35.23 | 104 | 157 | Peak |

Remarks:

- Emission Level = Read Level + Antenna Factor + Cable Loss - Preamp Factor
Margin value = Emission level – Limit value
- 5260 MHz: Fundamental Frequency

| EUT Test Condition | | Measurement Detail | |
|--------------------------|--------------------|--------------------|---------------------------|
| Channel | Channel 60 | Frequency Range | 1 GHz ~ 40 GHz |
| Input Power | 120 Vac, 60 Hz | Detector Function | Peak (PK) Average (AV) |
| Environmental Conditions | 25 deg. C, 65 % RH | Tested By | Charles Hsiao |

| Antenna Polarity & Test Distance: Horizontal at 3 m | | | | | | | | | | |
|---|-------------------------|-------------------|----------------|-------------|-----------------------|-----------------|--------------------|---------------------|----------------------|---------|
| Frequency (MHz) | Emission Level (dBuV/m) | Read Level (dBuV) | Limit (dBuV/m) | Margin (dB) | Antenna Factor (dB/m) | Cable Loss (dB) | Preamp Factor (dB) | Antenna Height (cm) | Table Angle (Degree) | Remark |
| 5123.9 | 42.9 | 34.68 | 54 | -11.1 | 34.11 | 8.1 | 33.99 | 198 | 304 | Average |
| 5147.3 | 53.8 | 45.55 | 74 | -20.2 | 34.12 | 8.13 | 34 | 198 | 304 | Peak |
| 5300 | 100.68 | 92.14 | | | 34.24 | 8.32 | 34.02 | 198 | 304 | Average |
| 5300 | 108.61 | 100.07 | | | 34.24 | 8.32 | 34.02 | 198 | 304 | Peak |
| 5350.66 | 44.87 | 36.24 | 54 | -9.13 | 34.28 | 8.38 | 34.03 | 198 | 304 | Average |
| 5384.21 | 54.86 | 46.18 | 74 | -19.14 | 34.31 | 8.41 | 34.04 | 198 | 304 | Peak |

| Antenna Polarity & Test Distance: Vertical at 3 m | | | | | | | | | | |
|---|-------------------------|-------------------|----------------|-------------|-----------------------|-----------------|--------------------|---------------------|----------------------|---------|
| Frequency (MHz) | Emission Level (dBuV/m) | Read Level (dBuV) | Limit (dBuV/m) | Margin (dB) | Antenna Factor (dB/m) | Cable Loss (dB) | Preamp Factor (dB) | Antenna Height (cm) | Table Angle (Degree) | Remark |
| 5062.25 | 54.4 | 46.3 | 74 | -19.6 | 34.05 | 8.03 | 33.98 | 123 | 289 | Peak |
| 5117.75 | 42.81 | 34.61 | 54 | -11.19 | 34.09 | 8.1 | 33.99 | 123 | 289 | Average |
| 5300 | 96.18 | 87.64 | | | 34.24 | 8.32 | 34.02 | 123 | 289 | Average |
| 5300 | 103.96 | 95.42 | | | 34.24 | 8.32 | 34.02 | 123 | 289 | Peak |
| 5352.53 | 43.1 | 34.47 | 54 | -10.9 | 34.28 | 8.38 | 34.03 | 123 | 289 | Average |
| 5444.27 | 53.22 | 44.43 | 74 | -20.78 | 34.35 | 8.48 | 34.04 | 123 | 289 | Peak |

Remarks:

- Emission Level = Read Level + Antenna Factor + Cable Loss - Preamp Factor
Margin value = Emission level – Limit value
- 5300 MHz: Fundamental Frequency

| EUT Test Condition | | Measurement Detail | |
|--------------------------|--------------------|--------------------|---------------------------|
| Channel | Channel 64 | Frequency Range | 1 GHz ~ 40 GHz |
| Input Power | 120 Vac, 60 Hz | Detector Function | Peak (PK) Average (AV) |
| Environmental Conditions | 25 deg. C, 65 % RH | Tested By | Charles Hsiao |

| Antenna Polarity & Test Distance: Horizontal at 3 m | | | | | | | | | | |
|---|-------------------------|-------------------|----------------|-------------|-----------------------|-----------------|--------------------|---------------------|----------------------|---------|
| Frequency (MHz) | Emission Level (dBuV/m) | Read Level (dBuV) | Limit (dBuV/m) | Margin (dB) | Antenna Factor (dB/m) | Cable Loss (dB) | Preamp Factor (dB) | Antenna Height (cm) | Table Angle (Degree) | Remark |
| 5320 | 99.83 | 91.25 | | | 34.25 | 8.35 | 34.02 | 198 | 304 | Average |
| 5320 | 107.95 | 99.37 | | | 34.25 | 8.35 | 34.02 | 198 | 304 | Peak |
| 5352.2 | 45.18 | 36.55 | 54 | -8.82 | 34.28 | 8.38 | 34.03 | 198 | 304 | Average |
| 5363.75 | 56.71 | 48.07 | 74 | -17.29 | 34.29 | 8.38 | 34.03 | 198 | 304 | Peak |
| 10640 | 48.99 | 34.26 | 54 | -5.01 | 37.31 | 12.71 | 35.29 | 112 | 154 | Average |
| 10640 | 57.54 | 42.81 | 74 | -16.46 | 37.31 | 12.71 | 35.29 | 112 | 154 | Peak |

| Antenna Polarity & Test Distance: Vertical at 3 m | | | | | | | | | | |
|---|-------------------------|-------------------|----------------|-------------|-----------------------|-----------------|--------------------|---------------------|----------------------|---------|
| Frequency (MHz) | Emission Level (dBuV/m) | Read Level (dBuV) | Limit (dBuV/m) | Margin (dB) | Antenna Factor (dB/m) | Cable Loss (dB) | Preamp Factor (dB) | Antenna Height (cm) | Table Angle (Degree) | Remark |
| 5320 | 94.74 | 86.16 | | | 34.25 | 8.35 | 34.02 | 103 | 289 | Average |
| 5320 | 102.16 | 93.58 | | | 34.25 | 8.35 | 34.02 | 103 | 289 | Peak |
| 5372.22 | 53.89 | 45.22 | 74 | -20.11 | 34.29 | 8.41 | 34.03 | 103 | 289 | Peak |
| 5453.18 | 43.07 | 34.25 | 54 | -10.93 | 34.36 | 8.51 | 34.05 | 103 | 289 | Average |
| 10640 | 49.28 | 34.55 | 54 | -4.72 | 37.31 | 12.71 | 35.29 | 108 | 195 | Average |
| 10640 | 56.96 | 42.23 | 74 | -17.04 | 37.31 | 12.71 | 35.29 | 108 | 195 | Peak |

Remarks:

- Emission Level = Read Level + Antenna Factor + Cable Loss - Preamp Factor
Margin value = Emission level – Limit value
- 5320 MHz: Fundamental Frequency

| EUT Test Condition | | Measurement Detail | |
|--------------------------|--------------------|--------------------|---------------------------|
| Channel | Channel 100 | Frequency Range | 1 GHz ~ 40 GHz |
| Input Power | 120 Vac, 60 Hz | Detector Function | Peak (PK) Average (AV) |
| Environmental Conditions | 25 deg. C, 65 % RH | Tested By | Charles Hsiao |

| Antenna Polarity & Test Distance: Horizontal at 3 m | | | | | | | | | | |
|---|-------------------------|-------------------|----------------|-------------|-----------------------|-----------------|--------------------|---------------------|----------------------|---------|
| Frequency (MHz) | Emission Level (dBuV/m) | Read Level (dBuV) | Limit (dBuV/m) | Margin (dB) | Antenna Factor (dB/m) | Cable Loss (dB) | Preamp Factor (dB) | Antenna Height (cm) | Table Angle (Degree) | Remark |
| 5442.96 | 54.81 | 46.02 | 74 | -19.19 | 34.35 | 8.48 | 34.04 | 224 | 70 | Peak |
| 5459.76 | 44.74 | 35.92 | 54 | -9.26 | 34.36 | 8.51 | 34.05 | 224 | 70 | Average |
| *5470.16 | 55.01 | 46.18 | 74 | -18.99 | 34.37 | 8.51 | 34.05 | 224 | 70 | Peak |
| *5470.96 | 45.44 | 36.58 | 54 | -8.56 | 34.37 | 8.54 | 34.05 | 224 | 70 | Average |
| 5500 | 101.87 | 92.95 | | | 34.4 | 8.57 | 34.05 | 224 | 70 | Average |
| 5500 | 108.17 | 99.25 | | | 34.4 | 8.57 | 34.05 | 224 | 70 | Peak |
| 11000 | 47.07 | 31.99 | 54 | -6.93 | 37.6 | 12.96 | 35.48 | 108 | 246 | Average |
| 11000 | 57.79 | 42.71 | 74 | -16.21 | 37.6 | 12.96 | 35.48 | 108 | 246 | Peak |

| Antenna Polarity & Test Distance: Vertical at 3 m | | | | | | | | | | |
|---|-------------------------|-------------------|----------------|-------------|-----------------------|-----------------|--------------------|---------------------|----------------------|---------|
| Frequency (MHz) | Emission Level (dBuV/m) | Read Level (dBuV) | Limit (dBuV/m) | Margin (dB) | Antenna Factor (dB/m) | Cable Loss (dB) | Preamp Factor (dB) | Antenna Height (cm) | Table Angle (Degree) | Remark |
| 5358.64 | 53.45 | 44.82 | 74 | -20.55 | 34.28 | 8.38 | 34.03 | 119 | 107 | Peak |
| 5458.64 | 43.71 | 34.89 | 54 | -10.29 | 34.36 | 8.51 | 34.05 | 119 | 107 | Average |
| *5468.24 | 53.73 | 44.9 | 74 | -20.27 | 34.37 | 8.51 | 34.05 | 119 | 107 | Peak |
| *5469.84 | 43.96 | 35.13 | 54 | -10.04 | 34.37 | 8.51 | 34.05 | 119 | 107 | Average |
| 5500 | 97.44 | 88.52 | | | 34.4 | 8.57 | 34.05 | 119 | 107 | Average |
| 5500 | 104.8 | 95.88 | | | 34.4 | 8.57 | 34.05 | 119 | 107 | Peak |
| 11000 | 46.78 | 31.7 | 54 | -7.22 | 37.6 | 12.96 | 35.48 | 129 | 354 | Average |
| 11000 | 57.19 | 42.11 | 74 | -16.81 | 37.6 | 12.96 | 35.48 | 129 | 354 | Peak |

Remarks:

- Emission Level = Read Level + Antenna Factor + Cable Loss - Preamp Factor
Margin value = Emission level – Limit value
- 5500 MHz: Fundamental Frequency
- *: Out of Restricted Band

| EUT Test Condition | | Measurement Detail | |
|--------------------------|--------------------|--------------------|---------------------------|
| Channel | Channel 116 | Frequency Range | 1 GHz ~ 40 GHz |
| Input Power | 120 Vac, 60 Hz | Detector Function | Peak (PK) Average (AV) |
| Environmental Conditions | 25 deg. C, 65 % RH | Tested By | Charles Hsiao |

| Antenna Polarity & Test Distance: Horizontal at 3 m | | | | | | | | | | |
|---|-------------------------|-------------------|----------------|-------------|-----------------------|-----------------|--------------------|---------------------|----------------------|---------|
| Frequency (MHz) | Emission Level (dBuV/m) | Read Level (dBuV) | Limit (dBuV/m) | Margin (dB) | Antenna Factor (dB/m) | Cable Loss (dB) | Preamp Factor (dB) | Antenna Height (cm) | Table Angle (Degree) | Remark |
| 5446.16 | 43.32 | 34.49 | 54 | -10.68 | 34.36 | 8.51 | 34.04 | 224 | 70 | Average |
| 5447.6 | 53.98 | 45.15 | 74 | -20.02 | 34.36 | 8.51 | 34.04 | 224 | 70 | Peak |
| *5468.72 | 43.35 | 34.52 | 54 | -10.65 | 34.37 | 8.51 | 34.05 | 224 | 70 | Average |
| *5469.84 | 53.79 | 44.96 | 74 | -20.21 | 34.37 | 8.51 | 34.05 | 224 | 70 | Peak |
| 5580 | 101.47 | 92.48 | | | 34.47 | 8.6 | 34.08 | 224 | 70 | Average |
| 5580 | 108.83 | 99.84 | | | 34.47 | 8.6 | 34.08 | 224 | 70 | Peak |
| *5724.28 | 44.04 | 34.88 | 54 | -9.96 | 34.62 | 8.65 | 34.11 | 224 | 70 | Average |
| *5725.56 | 53.14 | 43.98 | 74 | -20.86 | 34.62 | 8.65 | 34.11 | 224 | 70 | Peak |

| Antenna Polarity & Test Distance: Vertical at 3 m | | | | | | | | | | |
|---|-------------------------|-------------------|----------------|-------------|-----------------------|-----------------|--------------------|---------------------|----------------------|---------|
| Frequency (MHz) | Emission Level (dBuV/m) | Read Level (dBuV) | Limit (dBuV/m) | Margin (dB) | Antenna Factor (dB/m) | Cable Loss (dB) | Preamp Factor (dB) | Antenna Height (cm) | Table Angle (Degree) | Remark |
| 5370.96 | 54.08 | 45.41 | 74 | -19.92 | 34.29 | 8.41 | 34.03 | 119 | 107 | Peak |
| 5456.56 | 43.14 | 34.32 | 54 | -10.86 | 34.36 | 8.51 | 34.05 | 119 | 107 | Average |
| *5469.2 | 53.27 | 44.44 | 74 | -20.73 | 34.37 | 8.51 | 34.05 | 119 | 107 | Peak |
| *5470.8 | 43.21 | 34.35 | 54 | -10.79 | 34.37 | 8.54 | 34.05 | 119 | 107 | Average |
| 5580 | 97.49 | 88.5 | | | 34.47 | 8.6 | 34.08 | 119 | 107 | Average |
| 5580 | 104.64 | 95.65 | | | 34.47 | 8.6 | 34.08 | 119 | 107 | Peak |
| *5724.12 | 43.42 | 34.26 | 54 | -10.58 | 34.62 | 8.65 | 34.11 | 119 | 107 | Average |
| *5724.12 | 53.62 | 44.46 | 74 | -20.38 | 34.62 | 8.65 | 34.11 | 119 | 107 | Peak |

Remarks:

- Emission Level = Read Level + Antenna Factor + Cable Loss - Preamp Factor
Margin value = Emission level – Limit value
- 5580 MHz: Fundamental Frequency
- *: Out of Restricted Band

| EUT Test Condition | | Measurement Detail | |
|--------------------------|--------------------|--------------------|---------------------------|
| Channel | Channel 140 | Frequency Range | 1 GHz ~ 40 GHz |
| Input Power | 120 Vac, 60 Hz | Detector Function | Peak (PK) Average (AV) |
| Environmental Conditions | 25 deg. C, 65 % RH | Tested By | Charles Hsiao |

| Antenna Polarity & Test Distance: Horizontal at 3 m | | | | | | | | | | |
|---|-------------------------|-------------------|----------------|-------------|-----------------------|-----------------|--------------------|---------------------|----------------------|---------|
| Frequency (MHz) | Emission Level (dBuV/m) | Read Level (dBuV) | Limit (dBuV/m) | Margin (dB) | Antenna Factor (dB/m) | Cable Loss (dB) | Preamp Factor (dB) | Antenna Height (cm) | Table Angle (Degree) | Remark |
| 5700 | 100.41 | 91.28 | | | 34.59 | 8.64 | 34.1 | 224 | 70 | Average |
| 5700 | 107.56 | 98.43 | | | 34.59 | 8.64 | 34.1 | 224 | 70 | Peak |
| *5724.04 | 46.65 | 37.49 | 54 | -7.35 | 34.62 | 8.65 | 34.11 | 224 | 70 | Average |
| *5725.4 | 56.84 | 47.68 | 74 | -17.16 | 34.62 | 8.65 | 34.11 | 224 | 70 | Peak |
| 11400 | 46.71 | 31.61 | 54 | -7.29 | 37.84 | 12.67 | 35.41 | 105 | 240 | Average |
| 11400 | 57.07 | 41.97 | 74 | -16.93 | 37.84 | 12.67 | 35.41 | 105 | 240 | Peak |

| Antenna Polarity & Test Distance: Vertical at 3 m | | | | | | | | | | |
|---|-------------------------|-------------------|----------------|-------------|-----------------------|-----------------|--------------------|---------------------|----------------------|---------|
| Frequency (MHz) | Emission Level (dBuV/m) | Read Level (dBuV) | Limit (dBuV/m) | Margin (dB) | Antenna Factor (dB/m) | Cable Loss (dB) | Preamp Factor (dB) | Antenna Height (cm) | Table Angle (Degree) | Remark |
| 5700 | 96.62 | 87.49 | | | 34.59 | 8.64 | 34.1 | 119 | 107 | Average |
| 5700 | 103.58 | 94.45 | | | 34.59 | 8.64 | 34.1 | 119 | 107 | Peak |
| *5724.12 | 54.72 | 45.56 | 74 | -19.28 | 34.62 | 8.65 | 34.11 | 119 | 107 | Peak |
| *5725.16 | 45 | 35.84 | 54 | -9 | 34.62 | 8.65 | 34.11 | 119 | 107 | Average |
| 11400 | 46.81 | 31.71 | 54 | -7.19 | 37.84 | 12.67 | 35.41 | 180 | 246 | Average |
| 11400 | 57.18 | 42.08 | 74 | -16.82 | 37.84 | 12.67 | 35.41 | 180 | 246 | Peak |

Remarks:

- Emission Level = Read Level + Antenna Factor + Cable Loss - Preamp Factor
Margin value = Emission level – Limit value
- 5700 MHz: Fundamental Frequency
- *: Out of Restricted Band

| EUT Test Condition | | Measurement Detail | |
|--------------------------|--------------------|--------------------|---------------------------|
| Channel | Channel 149 | Frequency Range | 1 GHz ~ 40 GHz |
| Input Power | 120 Vac, 60 Hz | Detector Function | Peak (PK) Average (AV) |
| Environmental Conditions | 25 deg. C, 65 % RH | Tested By | Charles Hsiao |

<Spurious Emission>

| Antenna Polarity & Test Distance: Horizontal at 3 m | | | | | | | | | | |
|---|-------------------------|-------------------|----------------|-------------|-----------------------|-----------------|--------------------|---------------------|----------------------|---------|
| Frequency (MHz) | Emission Level (dBuV/m) | Read Level (dBuV) | Limit (dBuV/m) | Margin (dB) | Antenna Factor (dB/m) | Cable Loss (dB) | Preamp Factor (dB) | Antenna Height (cm) | Table Angle (Degree) | Remark |
| 5745 | 101.1 | 91.91 | | | 34.64 | 8.66 | 34.11 | 202 | 299 | Average |
| 5745 | 108.33 | 99.14 | | | 34.64 | 8.66 | 34.11 | 202 | 299 | Peak |
| 11490 | 47.52 | 32.4 | 54 | -6.48 | 37.89 | 12.62 | 35.39 | 196 | 340 | Average |
| 11490 | 56.72 | 41.6 | 74 | -17.28 | 37.89 | 12.62 | 35.39 | 196 | 340 | Peak |
| Antenna Polarity & Test Distance: Vertical at 3 m | | | | | | | | | | |
| Frequency (MHz) | Emission Level (dBuV/m) | Read Level (dBuV) | Limit (dBuV/m) | Margin (dB) | Antenna Factor (dB/m) | Cable Loss (dB) | Preamp Factor (dB) | Antenna Height (cm) | Table Angle (Degree) | Remark |
| 5745 | 95.67 | 86.48 | | | 34.64 | 8.66 | 34.11 | 126 | 354 | Average |
| 5745 | 103.08 | 93.89 | | | 34.64 | 8.66 | 34.11 | 126 | 354 | Peak |
| 11490 | 47.46 | 32.34 | 54 | -6.54 | 37.89 | 12.62 | 35.39 | 123 | 264 | Average |
| 11490 | 56.73 | 41.61 | 74 | -17.27 | 37.89 | 12.62 | 35.39 | 123 | 264 | Peak |

<Out of Band Emission (OOBE)>

| Antenna Polarity & Test Distance: Horizontal at 3 m | | | | | | | | | | |
|---|-------------------------|-------------------|----------------|-------------|-----------------------|-----------------|--------------------|---------------------|----------------------|---------|
| Frequency (MHz) | Emission Level (dBuV/m) | Read Level (dBuV) | Limit (dBuV/m) | Margin (dB) | Antenna Factor (dB/m) | Cable Loss (dB) | Preamp Factor (dB) | Antenna Height (cm) | Table Angle (Degree) | Remark |
| *5643.325 | 45.23 | 36.16 | 54 | -8.77 | 34.54 | 8.62 | 34.09 | 202 | 299 | Average |
| *5643.325 | 54.34 | 45.27 | 74 | -19.66 | 34.54 | 8.62 | 34.09 | 202 | 299 | Peak |
| 5650.675 | 53.75 | 44.66 | 74.42 | -20.67 | 34.56 | 8.62 | 34.09 | 202 | 299 | Peak |
| 5923.15 | 53.09 | 43.69 | 75.15 | -22.06 | 34.83 | 8.73 | 34.16 | 202 | 299 | Peak |
| *5987.725 | 44.69 | 35.23 | 54 | -9.31 | 34.88 | 8.75 | 34.17 | 202 | 299 | Average |
| *5987.725 | 53.94 | 44.48 | 74 | -20.06 | 34.88 | 8.75 | 34.17 | 202 | 299 | Peak |
| Antenna Polarity & Test Distance: Vertical at 3 m | | | | | | | | | | |
| Frequency (MHz) | Emission Level (dBuV/m) | Read Level (dBuV) | Limit (dBuV/m) | Margin (dB) | Antenna Factor (dB/m) | Cable Loss (dB) | Preamp Factor (dB) | Antenna Height (cm) | Table Angle (Degree) | Remark |
| *5630.2 | 45.4 | 36.35 | 54 | -8.6 | 34.52 | 8.62 | 34.09 | 126 | 354 | Average |
| *5630.2 | 54.09 | 45.04 | 74 | -19.91 | 34.52 | 8.62 | 34.09 | 126 | 354 | Peak |
| 5651.2 | 50.92 | 41.83 | 74.75 | -23.83 | 34.56 | 8.62 | 34.09 | 126 | 354 | Peak |
| 5923.675 | 53.25 | 43.85 | 74.83 | -21.58 | 34.83 | 8.73 | 34.16 | 126 | 354 | Peak |
| *6011.875 | 46.29 | 36.79 | 54 | -7.71 | 34.92 | 8.76 | 34.18 | 126 | 354 | Average |
| *6011.875 | 55.29 | 45.79 | 74 | -18.71 | 34.92 | 8.76 | 34.18 | 126 | 354 | Peak |

Remarks:

- Emission Level = Read Level + Antenna Factor + Cable Loss - Preamp Factor
Margin value = Emission level – Limit value
- 5745 MHz: Fundamental Frequency
- *: Out of Restricted Band

| EUT Test Condition | | Measurement Detail | |
|--------------------------|--------------------|--------------------|---------------------------|
| Channel | Channel 157 | Frequency Range | 1 GHz ~ 40 GHz |
| Input Power | 120 Vac, 60 Hz | Detector Function | Peak (PK) Average (AV) |
| Environmental Conditions | 25 deg. C, 65 % RH | Tested By | Charles Hsiao |

<Spurious Emission>

| Antenna Polarity & Test Distance: Horizontal at 3 m | | | | | | | | | | |
|---|-------------------------|-------------------|----------------|-------------|-----------------------|-----------------|--------------------|---------------------|----------------------|---------|
| Frequency (MHz) | Emission Level (dBuV/m) | Read Level (dBuV) | Limit (dBuV/m) | Margin (dB) | Antenna Factor (dB/m) | Cable Loss (dB) | Preamp Factor (dB) | Antenna Height (cm) | Table Angle (Degree) | Remark |
| 5785 | 100.7 | 91.47 | | | 34.68 | 8.68 | 34.13 | 202 | 299 | Average |
| 5785 | 108.12 | 98.89 | | | 34.68 | 8.68 | 34.13 | 202 | 299 | Peak |
| 11570 | 47.96 | 32.65 | 54 | -6.04 | 38 | 12.68 | 35.37 | 136 | 284 | Average |
| 11570 | 56.48 | 41.17 | 74 | -17.52 | 38 | 12.68 | 35.37 | 136 | 284 | Peak |
| Antenna Polarity & Test Distance: Vertical at 3 m | | | | | | | | | | |
| Frequency (MHz) | Emission Level (dBuV/m) | Read Level (dBuV) | Limit (dBuV/m) | Margin (dB) | Antenna Factor (dB/m) | Cable Loss (dB) | Preamp Factor (dB) | Antenna Height (cm) | Table Angle (Degree) | Remark |
| 5786 | 96.25 | 87.01 | | | 34.69 | 8.68 | 34.13 | 126 | 354 | Average |
| 5786 | 103.48 | 94.24 | | | 34.69 | 8.68 | 34.13 | 126 | 354 | Peak |
| 11570 | 47.54 | 32.23 | 54 | -6.46 | 38 | 12.68 | 35.37 | 173 | 69 | Average |
| 11570 | 56.85 | 41.54 | 74 | -17.15 | 38 | 12.68 | 35.37 | 173 | 69 | Peak |

<Out of Band Emission (OOBE)>

| Antenna Polarity & Test Distance: Horizontal at 3 m | | | | | | | | | | |
|---|-------------------------|-------------------|----------------|-------------|-----------------------|-----------------|--------------------|---------------------|----------------------|---------|
| Frequency (MHz) | Emission Level (dBuV/m) | Read Level (dBuV) | Limit (dBuV/m) | Margin (dB) | Antenna Factor (dB/m) | Cable Loss (dB) | Preamp Factor (dB) | Antenna Height (cm) | Table Angle (Degree) | Remark |
| *5556.175 | 46.09 | 37.12 | 54 | -7.91 | 34.45 | 8.59 | 34.07 | 202 | 299 | Average |
| *5556.175 | 55.32 | 46.35 | 74 | -18.68 | 34.45 | 8.59 | 34.07 | 202 | 299 | Peak |
| 5651.725 | 52.84 | 43.75 | 75.08 | -22.24 | 34.56 | 8.62 | 34.09 | 202 | 299 | Peak |
| 5922.625 | 52.53 | 43.13 | 75.48 | -22.95 | 34.83 | 8.73 | 34.16 | 202 | 299 | Peak |
| *5977.225 | 46.52 | 37.06 | 54 | -7.48 | 34.88 | 8.75 | 34.17 | 202 | 299 | Average |
| *5977.225 | 56.07 | 46.61 | 74 | -17.93 | 34.88 | 8.75 | 34.17 | 202 | 299 | Peak |
| Antenna Polarity & Test Distance: Vertical at 3 m | | | | | | | | | | |
| Frequency (MHz) | Emission Level (dBuV/m) | Read Level (dBuV) | Limit (dBuV/m) | Margin (dB) | Antenna Factor (dB/m) | Cable Loss (dB) | Preamp Factor (dB) | Antenna Height (cm) | Table Angle (Degree) | Remark |
| *5646.475 | 44.96 | 35.89 | 54 | -9.04 | 34.54 | 8.62 | 34.09 | 126 | 354 | Average |
| *5646.475 | 53.51 | 44.44 | 74 | -20.49 | 34.54 | 8.62 | 34.09 | 126 | 354 | Peak |
| 5651.725 | 51.71 | 42.62 | 75.08 | -23.37 | 34.56 | 8.62 | 34.09 | 126 | 354 | Peak |
| 5923.675 | 52.94 | 43.54 | 74.83 | -21.89 | 34.83 | 8.73 | 34.16 | 126 | 354 | Peak |
| *5988.775 | 45.34 | 35.88 | 54 | -8.66 | 34.88 | 8.75 | 34.17 | 126 | 354 | Average |
| *5988.775 | 54.24 | 44.78 | 74 | -19.76 | 34.88 | 8.75 | 34.17 | 126 | 354 | Peak |

Remarks:

- Emission Level = Read Level + Antenna Factor + Cable Loss - Preamp Factor
Margin value = Emission level – Limit value
- 5785 MHz: Fundamental Frequency
- *: Out of Restricted Band

| EUT Test Condition | | Measurement Detail | |
|--------------------------|--------------------|--------------------|---------------------------|
| Channel | Channel 165 | Frequency Range | 1 GHz ~ 40 GHz |
| Input Power | 120 Vac, 60 Hz | Detector Function | Peak (PK) Average (AV) |
| Environmental Conditions | 25 deg. C, 65 % RH | Tested By | Charles Hsiao |

<Spurious Emission>

| Antenna Polarity & Test Distance: Horizontal at 3 m | | | | | | | | | | |
|---|-------------------------|-------------------|----------------|-------------|-----------------------|-----------------|--------------------|---------------------|----------------------|---------|
| Frequency (MHz) | Emission Level (dBuV/m) | Read Level (dBuV) | Limit (dBuV/m) | Margin (dB) | Antenna Factor (dB/m) | Cable Loss (dB) | Preamp Factor (dB) | Antenna Height (cm) | Table Angle (Degree) | Remark |
| 5825 | 101.22 | 91.93 | | | 34.73 | 8.69 | 34.13 | 202 | 299 | Average |
| 5825 | 108.34 | 99.05 | | | 34.73 | 8.69 | 34.13 | 202 | 299 | Peak |
| 11650 | 47.63 | 32.1 | 54 | -6.37 | 38.09 | 12.8 | 35.36 | 168 | 107 | Average |
| 11650 | 56.87 | 41.34 | 74 | -17.13 | 38.09 | 12.8 | 35.36 | 168 | 107 | Peak |
| Antenna Polarity & Test Distance: Vertical at 3 m | | | | | | | | | | |
| Frequency (MHz) | Emission Level (dBuV/m) | Read Level (dBuV) | Limit (dBuV/m) | Margin (dB) | Antenna Factor (dB/m) | Cable Loss (dB) | Preamp Factor (dB) | Antenna Height (cm) | Table Angle (Degree) | Remark |
| 5825 | 96.05 | 86.76 | | | 34.73 | 8.69 | 34.13 | 126 | 354 | Average |
| 5825 | 103.29 | 94 | | | 34.73 | 8.69 | 34.13 | 126 | 354 | Peak |
| 11650 | 48.32 | 32.79 | 54 | -5.68 | 38.09 | 12.8 | 35.36 | 158 | 133 | Average |
| 11650 | 57.64 | 42.11 | 74 | -16.36 | 38.09 | 12.8 | 35.36 | 158 | 133 | Peak |

<Out of Band Emission (OOBE)>

| Antenna Polarity & Test Distance: Horizontal at 3 m | | | | | | | | | | |
|---|-------------------------|-------------------|----------------|-------------|-----------------------|-----------------|--------------------|---------------------|----------------------|---------|
| Frequency (MHz) | Emission Level (dBuV/m) | Read Level (dBuV) | Limit (dBuV/m) | Margin (dB) | Antenna Factor (dB/m) | Cable Loss (dB) | Preamp Factor (dB) | Antenna Height (cm) | Table Angle (Degree) | Remark |
| *5581.375 | 45.26 | 36.27 | 54 | -8.74 | 34.47 | 8.6 | 34.08 | 202 | 299 | Average |
| *5581.375 | 54.88 | 45.89 | 74 | -19.12 | 34.47 | 8.6 | 34.08 | 202 | 299 | Peak |
| 5651.725 | 52.8 | 43.71 | 75.08 | -22.28 | 34.56 | 8.62 | 34.09 | 202 | 299 | Peak |
| 5923.15 | 53.11 | 43.71 | 75.15 | -22.04 | 34.83 | 8.73 | 34.16 | 202 | 299 | Peak |
| *5933.65 | 45.58 | 36.18 | 54 | -8.42 | 34.83 | 8.73 | 34.16 | 202 | 299 | Average |
| *5933.65 | 54.47 | 45.07 | 74 | -19.53 | 34.83 | 8.73 | 34.16 | 202 | 299 | Peak |
| Antenna Polarity & Test Distance: Vertical at 3 m | | | | | | | | | | |
| Frequency (MHz) | Emission Level (dBuV/m) | Read Level (dBuV) | Limit (dBuV/m) | Margin (dB) | Antenna Factor (dB/m) | Cable Loss (dB) | Preamp Factor (dB) | Antenna Height (cm) | Table Angle (Degree) | Remark |
| *5519.425 | 45.28 | 36.35 | 54 | -8.72 | 34.42 | 8.57 | 34.06 | 126 | 354 | Average |
| *5519.425 | 54.38 | 45.45 | 74 | -19.62 | 34.42 | 8.57 | 34.06 | 126 | 354 | Peak |
| 5652.775 | 52.87 | 43.77 | 75.73 | -22.86 | 34.56 | 8.63 | 34.09 | 126 | 354 | Peak |
| 5923.15 | 53.07 | 43.67 | 75.15 | -22.08 | 34.83 | 8.73 | 34.16 | 126 | 354 | Peak |
| *5994.025 | 46.21 | 36.72 | 54 | -7.79 | 34.9 | 8.76 | 34.17 | 126 | 354 | Average |
| *5994.025 | 55.03 | 45.54 | 74 | -18.97 | 34.9 | 8.76 | 34.17 | 126 | 354 | Peak |

Remarks:

- Emission Level = Read Level + Antenna Factor + Cable Loss - Preamp Factor
Margin value = Emission level – Limit value
- 5825 MHz: Fundamental Frequency
- *: Out of Restricted Band

802.11n (HT20)

| EUT Test Condition | | Measurement Detail | |
|--------------------------|--------------------|--------------------|---------------------------|
| Channel | Channel 36 | Frequency Range | 1 GHz ~ 40 GHz |
| Input Power | 120 Vac, 60 Hz | Detector Function | Peak (PK) Average (AV) |
| Environmental Conditions | 25 deg. C, 65 % RH | Tested By | Charles Hsiao |

Antenna Polarity & Test Distance: Horizontal at 3 m

| Frequency (MHz) | Emission Level (dBuV/m) | Read Level (dBuV) | Limit (dBuV/m) | Margin (dB) | Antenna Factor (dB/m) | Cable Loss (dB) | Preamp Factor (dB) | Antenna Height (cm) | Table Angle (Degree) | Remark |
|-----------------|-------------------------|-------------------|----------------|-------------|-----------------------|-----------------|--------------------|---------------------|----------------------|---------|
| 5141.9 | 54.95 | 46.69 | 74 | -19.05 | 34.12 | 8.13 | 33.99 | 235 | 69 | Peak |
| 5147.45 | 44.73 | 36.48 | 54 | -9.27 | 34.12 | 8.13 | 34 | 235 | 69 | Average |
| 5180 | 100.36 | 92.05 | | | 34.15 | 8.16 | 34 | 235 | 69 | Average |
| 5180 | 107.68 | 99.37 | | | 34.15 | 8.16 | 34 | 235 | 69 | Peak |
| 10360 | 46.36 | 32.06 | 54 | -7.64 | 37.12 | 12.3 | 35.12 | 154 | 255 | Average |
| 10360 | 55.1 | 40.8 | 74 | -18.9 | 37.12 | 12.3 | 35.12 | 154 | 255 | Peak |

Antenna Polarity & Test Distance: Vertical at 3 m

| Frequency (MHz) | Emission Level (dBuV/m) | Read Level (dBuV) | Limit (dBuV/m) | Margin (dB) | Antenna Factor (dB/m) | Cable Loss (dB) | Preamp Factor (dB) | Antenna Height (cm) | Table Angle (Degree) | Remark |
|-----------------|-------------------------|-------------------|----------------|-------------|-----------------------|-----------------|--------------------|---------------------|----------------------|---------|
| 5120 | 54.19 | 45.99 | 74 | -19.81 | 34.09 | 8.1 | 33.99 | 106 | 96 | Peak |
| 5131.25 | 44 | 35.78 | 54 | -10 | 34.11 | 8.1 | 33.99 | 106 | 96 | Average |
| 5180 | 96.47 | 88.16 | | | 34.15 | 8.16 | 34 | 106 | 96 | Average |
| 5180 | 103.31 | 95 | | | 34.15 | 8.16 | 34 | 106 | 96 | Peak |
| 10360 | 46.19 | 31.89 | 54 | -7.81 | 37.12 | 12.3 | 35.12 | 195 | 350 | Average |
| 10360 | 55.77 | 41.47 | 74 | -18.23 | 37.12 | 12.3 | 35.12 | 195 | 350 | Peak |

Remarks:

- Emission Level = Read Level + Antenna Factor + Cable Loss - Preamp Factor
Margin value = Emission level – Limit value
- 5180 MHz: Fundamental Frequency

| EUT Test Condition | | Measurement Detail | |
|--------------------------|--------------------|--------------------|---------------------------|
| Channel | Channel 44 | Frequency Range | 1 GHz ~ 40 GHz |
| Input Power | 120 Vac, 60 Hz | Detector Function | Peak (PK) Average (AV) |
| Environmental Conditions | 25 deg. C, 65 % RH | Tested By | Charles Hsiao |

| Antenna Polarity & Test Distance: Horizontal at 3 m | | | | | | | | | | |
|---|-------------------------|-------------------|----------------|-------------|-----------------------|-----------------|--------------------|---------------------|----------------------|---------|
| Frequency (MHz) | Emission Level (dBuV/m) | Read Level (dBuV) | Limit (dBuV/m) | Margin (dB) | Antenna Factor (dB/m) | Cable Loss (dB) | Preamp Factor (dB) | Antenna Height (cm) | Table Angle (Degree) | Remark |
| 5145.05 | 53.87 | 45.62 | 74 | -20.13 | 34.12 | 8.13 | 34 | 235 | 69 | Peak |
| 5148.5 | 43.67 | 35.42 | 54 | -10.33 | 34.12 | 8.13 | 34 | 235 | 69 | Average |
| 5220 | 100.74 | 92.35 | | | 34.17 | 8.22 | 34 | 235 | 69 | Average |
| 5220 | 107.02 | 98.63 | | | 34.17 | 8.22 | 34 | 235 | 69 | Peak |
| 5439.1 | 54.35 | 45.56 | 74 | -19.65 | 34.35 | 8.48 | 34.04 | 235 | 69 | Peak |
| 5452.74 | 43.46 | 34.64 | 54 | -10.54 | 34.36 | 8.51 | 34.05 | 235 | 69 | Average |

| Antenna Polarity & Test Distance: Vertical at 3 m | | | | | | | | | | |
|---|-------------------------|-------------------|----------------|-------------|-----------------------|-----------------|--------------------|---------------------|----------------------|---------|
| Frequency (MHz) | Emission Level (dBuV/m) | Read Level (dBuV) | Limit (dBuV/m) | Margin (dB) | Antenna Factor (dB/m) | Cable Loss (dB) | Preamp Factor (dB) | Antenna Height (cm) | Table Angle (Degree) | Remark |
| 5127.35 | 53.74 | 45.52 | 74 | -20.26 | 34.11 | 8.1 | 33.99 | 106 | 96 | Peak |
| 5145.95 | 43.2 | 34.95 | 54 | -10.8 | 34.12 | 8.13 | 34 | 106 | 96 | Average |
| 5220 | 96.66 | 88.27 | | | 34.17 | 8.22 | 34 | 106 | 96 | Average |
| 5220 | 103.38 | 94.99 | | | 34.17 | 8.22 | 34 | 106 | 96 | Peak |
| 5386.63 | 43.27 | 34.59 | 54 | -10.73 | 34.31 | 8.41 | 34.04 | 106 | 96 | Average |
| 5408.85 | 53.65 | 44.93 | 74 | -20.35 | 34.32 | 8.44 | 34.04 | 106 | 96 | Peak |

Remarks:

- Emission Level = Read Level + Antenna Factor + Cable Loss - Preamp Factor
Margin value = Emission level – Limit value
- 5220 MHz: Fundamental Frequency

| EUT Test Condition | | Measurement Detail | |
|--------------------------|--------------------|--------------------|---------------------------|
| Channel | Channel 48 | Frequency Range | 1 GHz ~ 40 GHz |
| Input Power | 120 Vac, 60 Hz | Detector Function | Peak (PK) Average (AV) |
| Environmental Conditions | 25 deg. C, 65 % RH | Tested By | Charles Hsiao |

| Antenna Polarity & Test Distance: Horizontal at 3 m | | | | | | | | | | |
|---|-------------------------|-------------------|----------------|-------------|-----------------------|-----------------|--------------------|---------------------|----------------------|---------|
| Frequency (MHz) | Emission Level (dBuV/m) | Read Level (dBuV) | Limit (dBuV/m) | Margin (dB) | Antenna Factor (dB/m) | Cable Loss (dB) | Preamp Factor (dB) | Antenna Height (cm) | Table Angle (Degree) | Remark |
| 5240 | 100.47 | 92.03 | | | 34.19 | 8.26 | 34.01 | 235 | 69 | Average |
| 5240 | 107.27 | 98.83 | | | 34.19 | 8.26 | 34.01 | 235 | 69 | Peak |
| 5352.64 | 54.51 | 45.88 | 74 | -19.49 | 34.28 | 8.38 | 34.03 | 235 | 69 | Peak |
| 5447.13 | 43.49 | 34.66 | 54 | -10.51 | 34.36 | 8.51 | 34.04 | 235 | 69 | Average |
| 10480 | 46.65 | 32.14 | 54 | -7.35 | 37.19 | 12.53 | 35.21 | 114 | 198 | Average |
| 10480 | 56.92 | 42.41 | 74 | -17.08 | 37.19 | 12.53 | 35.21 | 114 | 198 | Peak |

| Antenna Polarity & Test Distance: Vertical at 3 m | | | | | | | | | | |
|---|-------------------------|-------------------|----------------|-------------|-----------------------|-----------------|--------------------|---------------------|----------------------|---------|
| Frequency (MHz) | Emission Level (dBuV/m) | Read Level (dBuV) | Limit (dBuV/m) | Margin (dB) | Antenna Factor (dB/m) | Cable Loss (dB) | Preamp Factor (dB) | Antenna Height (cm) | Table Angle (Degree) | Remark |
| 5240 | 96.35 | 87.91 | | | 34.19 | 8.26 | 34.01 | 106 | 96 | Average |
| 5240 | 103.41 | 94.97 | | | 34.19 | 8.26 | 34.01 | 106 | 96 | Peak |
| 5361.77 | 53.5 | 44.86 | 74 | -20.5 | 34.29 | 8.38 | 34.03 | 106 | 96 | Peak |
| 5458.02 | 43.26 | 34.44 | 54 | -10.74 | 34.36 | 8.51 | 34.05 | 106 | 96 | Average |
| 10480 | 46.73 | 32.22 | 54 | -7.27 | 37.19 | 12.53 | 35.21 | 119 | 324 | Average |
| 10480 | 56.58 | 42.07 | 74 | -17.42 | 37.19 | 12.53 | 35.21 | 119 | 324 | Peak |

Remarks:

- Emission Level = Read Level + Antenna Factor + Cable Loss - Preamp Factor
Margin value = Emission level – Limit value
- 5240 MHz: Fundamental Frequency

| EUT Test Condition | | Measurement Detail | |
|--------------------------|--------------------|--------------------|---------------------------|
| Channel | Channel 52 | Frequency Range | 1 GHz ~ 40 GHz |
| Input Power | 120 Vac, 60 Hz | Detector Function | Peak (PK) Average (AV) |
| Environmental Conditions | 25 deg. C, 65 % RH | Tested By | Charles Hsiao |

| Antenna Polarity & Test Distance: Horizontal at 3 m | | | | | | | | | | |
|---|-------------------------|-------------------|----------------|-------------|-----------------------|-----------------|--------------------|---------------------|----------------------|---------|
| Frequency (MHz) | Emission Level (dBuV/m) | Read Level (dBuV) | Limit (dBuV/m) | Margin (dB) | Antenna Factor (dB/m) | Cable Loss (dB) | Preamp Factor (dB) | Antenna Height (cm) | Table Angle (Degree) | Remark |
| 5130.05 | 52.87 | 44.65 | 74 | -21.13 | 34.11 | 8.1 | 33.99 | 123 | 289 | Peak |
| 5141.15 | 42.92 | 34.66 | 54 | -11.08 | 34.12 | 8.13 | 33.99 | 123 | 289 | Average |
| 5260 | 95.99 | 87.53 | | | 34.21 | 8.26 | 34.01 | 123 | 289 | Average |
| 5260 | 103.76 | 95.3 | | | 34.21 | 8.26 | 34.01 | 123 | 289 | Peak |
| 10520 | 48.76 | 34.17 | 54 | -5.24 | 37.21 | 12.61 | 35.23 | 116 | 118 | Average |
| 10520 | 56.85 | 42.26 | 74 | -17.15 | 37.21 | 12.61 | 35.23 | 116 | 118 | Peak |

| Antenna Polarity & Test Distance: Vertical at 3 m | | | | | | | | | | |
|---|-------------------------|-------------------|----------------|-------------|-----------------------|-----------------|--------------------|---------------------|----------------------|---------|
| Frequency (MHz) | Emission Level (dBuV/m) | Read Level (dBuV) | Limit (dBuV/m) | Margin (dB) | Antenna Factor (dB/m) | Cable Loss (dB) | Preamp Factor (dB) | Antenna Height (cm) | Table Angle (Degree) | Remark |
| 5129.9 | 54.05 | 45.83 | 74 | -19.95 | 34.11 | 8.1 | 33.99 | 198 | 304 | Peak |
| 5139.2 | 42.88 | 34.63 | 54 | -11.12 | 34.11 | 8.13 | 33.99 | 198 | 304 | Average |
| 5260 | 99.93 | 91.47 | | | 34.21 | 8.26 | 34.01 | 198 | 304 | Average |
| 5260 | 108.12 | 99.66 | | | 34.21 | 8.26 | 34.01 | 198 | 304 | Peak |
| 10520 | 48.2 | 33.61 | 54 | -5.8 | 37.21 | 12.61 | 35.23 | 113 | 221 | Average |
| 10520 | 56.46 | 41.87 | 74 | -17.54 | 37.21 | 12.61 | 35.23 | 113 | 221 | Peak |

Remarks:

- Emission Level = Read Level + Antenna Factor + Cable Loss - Preamp Factor
Margin value = Emission level – Limit value
- 5260 MHz: Fundamental Frequency

| EUT Test Condition | | Measurement Detail | |
|--------------------------|--------------------|--------------------|---------------------------|
| Channel | Channel 60 | Frequency Range | 1 GHz ~ 40 GHz |
| Input Power | 120 Vac, 60 Hz | Detector Function | Peak (PK) Average (AV) |
| Environmental Conditions | 25 deg. C, 65 % RH | Tested By | Charles Hsiao |

| Antenna Polarity & Test Distance: Horizontal at 3 m | | | | | | | | | | |
|---|-------------------------|-------------------|----------------|-------------|-----------------------|-----------------|--------------------|---------------------|----------------------|---------|
| Frequency (MHz) | Emission Level (dBuV/m) | Read Level (dBuV) | Limit (dBuV/m) | Margin (dB) | Antenna Factor (dB/m) | Cable Loss (dB) | Preamp Factor (dB) | Antenna Height (cm) | Table Angle (Degree) | Remark |
| 5060.3 | 53.71 | 45.61 | 74 | -20.29 | 34.05 | 8.03 | 33.98 | 123 | 289 | Peak |
| 5138.3 | 42.72 | 34.47 | 54 | -11.28 | 34.11 | 8.13 | 33.99 | 123 | 289 | Average |
| 5300 | 94.77 | 86.23 | | | 34.24 | 8.32 | 34.02 | 123 | 289 | Average |
| 5300 | 102.44 | 93.9 | | | 34.24 | 8.32 | 34.02 | 123 | 289 | Peak |
| 5365.07 | 43.3 | 34.66 | 54 | -10.7 | 34.29 | 8.38 | 34.03 | 123 | 289 | Average |
| 5416.33 | 53.84 | 45.11 | 74 | -20.16 | 34.33 | 8.44 | 34.04 | 123 | 289 | Peak |

| Antenna Polarity & Test Distance: Vertical at 3 m | | | | | | | | | | |
|---|-------------------------|-------------------|----------------|-------------|-----------------------|-----------------|--------------------|---------------------|----------------------|---------|
| Frequency (MHz) | Emission Level (dBuV/m) | Read Level (dBuV) | Limit (dBuV/m) | Margin (dB) | Antenna Factor (dB/m) | Cable Loss (dB) | Preamp Factor (dB) | Antenna Height (cm) | Table Angle (Degree) | Remark |
| 5075.15 | 54.11 | 45.99 | 74 | -19.89 | 34.07 | 8.03 | 33.98 | 198 | 304 | Peak |
| 5126.15 | 42.93 | 34.71 | 54 | -11.07 | 34.11 | 8.1 | 33.99 | 198 | 304 | Average |
| 5300 | 100.79 | 92.25 | | | 34.24 | 8.32 | 34.02 | 198 | 304 | Average |
| 5300 | 108.3 | 99.76 | | | 34.24 | 8.32 | 34.02 | 198 | 304 | Peak |
| 5350 | 46.86 | 38.23 | 54 | -7.14 | 34.28 | 8.38 | 34.03 | 198 | 304 | Average |
| 5351.21 | 56.85 | 48.22 | 74 | -17.15 | 34.28 | 8.38 | 34.03 | 198 | 304 | Peak |

Remarks:

- Emission Level = Read Level + Antenna Factor + Cable Loss - Preamp Factor
Margin value = Emission level – Limit value
- 5300 MHz: Fundamental Frequency

| EUT Test Condition | | Measurement Detail | |
|--------------------------|--------------------|--------------------|---------------------------|
| Channel | Channel 64 | Frequency Range | 1 GHz ~ 40 GHz |
| Input Power | 120 Vac, 60 Hz | Detector Function | Peak (PK) Average (AV) |
| Environmental Conditions | 25 deg. C, 65 % RH | Tested By | Charles Hsiao |

| Antenna Polarity & Test Distance: Horizontal at 3 m | | | | | | | | | | |
|---|-------------------------|-------------------|----------------|-------------|-----------------------|-----------------|--------------------|---------------------|----------------------|---------|
| Frequency (MHz) | Emission Level (dBuV/m) | Read Level (dBuV) | Limit (dBuV/m) | Margin (dB) | Antenna Factor (dB/m) | Cable Loss (dB) | Preamp Factor (dB) | Antenna Height (cm) | Table Angle (Degree) | Remark |
| 5320 | 94.74 | 86.16 | | | 34.25 | 8.35 | 34.02 | 103 | 289 | Average |
| 5320 | 102.69 | 94.11 | | | 34.25 | 8.35 | 34.02 | 103 | 289 | Peak |
| 5350.22 | 43.4 | 34.77 | 54 | -10.6 | 34.28 | 8.38 | 34.03 | 103 | 289 | Average |
| 5381.46 | 54.84 | 46.16 | 74 | -19.16 | 34.31 | 8.41 | 34.04 | 103 | 289 | Peak |
| 10640 | 48.25 | 33.52 | 54 | -5.75 | 37.31 | 12.71 | 35.29 | 121 | 169 | Average |
| 10640 | 56.91 | 42.18 | 74 | -17.09 | 37.31 | 12.71 | 35.29 | 121 | 169 | Peak |

| Antenna Polarity & Test Distance: Vertical at 3 m | | | | | | | | | | |
|---|-------------------------|-------------------|----------------|-------------|-----------------------|-----------------|--------------------|---------------------|----------------------|---------|
| Frequency (MHz) | Emission Level (dBuV/m) | Read Level (dBuV) | Limit (dBuV/m) | Margin (dB) | Antenna Factor (dB/m) | Cable Loss (dB) | Preamp Factor (dB) | Antenna Height (cm) | Table Angle (Degree) | Remark |
| 5320 | 99.93 | 91.35 | | | 34.25 | 8.35 | 34.02 | 198 | 304 | Average |
| 5320 | 107.93 | 99.35 | | | 34.25 | 8.35 | 34.02 | 198 | 304 | Peak |
| 5353.08 | 47.23 | 38.6 | 54 | -6.77 | 34.28 | 8.38 | 34.03 | 198 | 304 | Average |
| 5365.73 | 57.43 | 48.79 | 74 | -16.57 | 34.29 | 8.38 | 34.03 | 198 | 304 | Peak |
| 10640 | 48.58 | 33.85 | 54 | -5.42 | 37.31 | 12.71 | 35.29 | 118 | 219 | Average |
| 10640 | 56.94 | 42.21 | 74 | -17.06 | 37.31 | 12.71 | 35.29 | 118 | 219 | Peak |

Remarks:

- Emission Level = Read Level + Antenna Factor + Cable Loss - Preamp Factor
Margin value = Emission level – Limit value
- 5320 MHz: Fundamental Frequency

| EUT Test Condition | | Measurement Detail | |
|--------------------------|--------------------|--------------------|---------------------------|
| Channel | Channel 100 | Frequency Range | 1 GHz ~ 40 GHz |
| Input Power | 120 Vac, 60 Hz | Detector Function | Peak (PK) Average (AV) |
| Environmental Conditions | 25 deg. C, 65 % RH | Tested By | Charles Hsiao |

| Antenna Polarity & Test Distance: Horizontal at 3 m | | | | | | | | | | |
|---|-------------------------|-------------------|----------------|-------------|-----------------------|-----------------|--------------------|---------------------|----------------------|---------|
| Frequency (MHz) | Emission Level (dBuV/m) | Read Level (dBuV) | Limit (dBuV/m) | Margin (dB) | Antenna Factor (dB/m) | Cable Loss (dB) | Preamp Factor (dB) | Antenna Height (cm) | Table Angle (Degree) | Remark |
| 5441.52 | 44.96 | 36.17 | 54 | -9.04 | 34.35 | 8.48 | 34.04 | 224 | 70 | Average |
| 5445.04 | 54.63 | 45.81 | 74 | -19.37 | 34.35 | 8.51 | 34.04 | 224 | 70 | Peak |
| *5470.64 | 45.33 | 36.5 | 54 | -8.67 | 34.37 | 8.51 | 34.05 | 224 | 70 | Average |
| *5470.8 | 54.75 | 45.89 | 74 | -19.25 | 34.37 | 8.54 | 34.05 | 224 | 70 | Peak |
| 5500 | 100.24 | 91.32 | | | 34.4 | 8.57 | 34.05 | 224 | 70 | Average |
| 5500 | 107.74 | 98.82 | | | 34.4 | 8.57 | 34.05 | 224 | 70 | Peak |
| 11000 | 46.97 | 31.89 | 54 | -7.03 | 37.6 | 12.96 | 35.48 | 180 | 9 | Average |
| 11000 | 57.01 | 41.93 | 74 | -16.99 | 37.6 | 12.96 | 35.48 | 180 | 9 | Peak |

| Antenna Polarity & Test Distance: Vertical at 3 m | | | | | | | | | | |
|---|-------------------------|-------------------|----------------|-------------|-----------------------|-----------------|--------------------|---------------------|----------------------|---------|
| Frequency (MHz) | Emission Level (dBuV/m) | Read Level (dBuV) | Limit (dBuV/m) | Margin (dB) | Antenna Factor (dB/m) | Cable Loss (dB) | Preamp Factor (dB) | Antenna Height (cm) | Table Angle (Degree) | Remark |
| 5384.08 | 53.91 | 45.23 | 74 | -20.09 | 34.31 | 8.41 | 34.04 | 119 | 107 | Peak |
| 5455.6 | 43.8 | 34.98 | 54 | -10.2 | 34.36 | 8.51 | 34.05 | 119 | 107 | Average |
| *5468.4 | 53.38 | 44.55 | 74 | -20.62 | 34.37 | 8.51 | 34.05 | 119 | 107 | Peak |
| *5469.52 | 44.25 | 35.42 | 54 | -9.75 | 34.37 | 8.51 | 34.05 | 119 | 107 | Average |
| 5500 | 97.15 | 88.23 | | | 34.4 | 8.57 | 34.05 | 119 | 107 | Average |
| 5500 | 104.17 | 95.25 | | | 34.4 | 8.57 | 34.05 | 119 | 107 | Peak |
| 11000 | 46.57 | 31.49 | 54 | -7.43 | 37.6 | 12.96 | 35.48 | 181 | 322 | Average |
| 11000 | 57.38 | 42.3 | 74 | -16.62 | 37.6 | 12.96 | 35.48 | 181 | 322 | Peak |

Remarks:

- Emission Level = Read Level + Antenna Factor + Cable Loss - Preamp Factor
Margin value = Emission level – Limit value
- 5500 MHz: Fundamental Frequency
- *: Out of Restricted Band

| EUT Test Condition | | Measurement Detail | |
|--------------------------|--------------------|--------------------|---------------------------|
| Channel | Channel 116 | Frequency Range | 1 GHz ~ 40 GHz |
| Input Power | 120 Vac, 60 Hz | Detector Function | Peak (PK) Average (AV) |
| Environmental Conditions | 25 deg. C, 65 % RH | Tested By | Charles Hsiao |

| Antenna Polarity & Test Distance: Horizontal at 3 m | | | | | | | | | | |
|---|-------------------------|-------------------|----------------|-------------|-----------------------|-----------------|--------------------|---------------------|----------------------|---------|
| Frequency (MHz) | Emission Level (dBuV/m) | Read Level (dBuV) | Limit (dBuV/m) | Margin (dB) | Antenna Factor (dB/m) | Cable Loss (dB) | Preamp Factor (dB) | Antenna Height (cm) | Table Angle (Degree) | Remark |
| 5365.84 | 53.63 | 44.99 | 74 | -20.37 | 34.29 | 8.38 | 34.03 | 224 | 70 | Peak |
| 5460 | 43.38 | 34.56 | 54 | -10.62 | 34.36 | 8.51 | 34.05 | 224 | 70 | Average |
| *5468.72 | 43.44 | 34.61 | 54 | -10.56 | 34.37 | 8.51 | 34.05 | 224 | 70 | Average |
| *5470 | 52.92 | 44.09 | 74 | -21.08 | 34.37 | 8.51 | 34.05 | 224 | 70 | Peak |
| 5580 | 101.47 | 92.48 | | | 34.47 | 8.6 | 34.08 | 224 | 70 | Average |
| 5580 | 108.65 | 99.66 | | | 34.47 | 8.6 | 34.08 | 224 | 70 | Peak |
| *5724.84 | 53.1 | 43.94 | 74 | -20.9 | 34.62 | 8.65 | 34.11 | 224 | 70 | Peak |
| *5725.48 | 43.87 | 34.71 | 54 | -10.13 | 34.62 | 8.65 | 34.11 | 224 | 70 | Average |

| Antenna Polarity & Test Distance: Vertical at 3 m | | | | | | | | | | |
|---|-------------------------|-------------------|----------------|-------------|-----------------------|-----------------|--------------------|---------------------|----------------------|---------|
| Frequency (MHz) | Emission Level (dBuV/m) | Read Level (dBuV) | Limit (dBuV/m) | Margin (dB) | Antenna Factor (dB/m) | Cable Loss (dB) | Preamp Factor (dB) | Antenna Height (cm) | Table Angle (Degree) | Remark |
| 5413.36 | 53.63 | 44.9 | 74 | -20.37 | 34.33 | 8.44 | 34.04 | 119 | 107 | Peak |
| 5456.08 | 43.17 | 34.35 | 54 | -10.83 | 34.36 | 8.51 | 34.05 | 119 | 107 | Average |
| *5468.08 | 43.03 | 34.2 | 54 | -10.97 | 34.37 | 8.51 | 34.05 | 119 | 107 | Average |
| *5468.4 | 52.57 | 43.74 | 74 | -21.43 | 34.37 | 8.51 | 34.05 | 119 | 107 | Peak |
| 5580 | 97.85 | 88.86 | | | 34.47 | 8.6 | 34.08 | 119 | 107 | Average |
| 5580 | 104.19 | 95.2 | | | 34.47 | 8.6 | 34.08 | 119 | 107 | Peak |
| *5724.76 | 43.57 | 34.41 | 54 | -10.43 | 34.62 | 8.65 | 34.11 | 119 | 107 | Average |
| *5724.76 | 52.62 | 43.46 | 74 | -21.38 | 34.62 | 8.65 | 34.11 | 119 | 107 | Peak |

Remarks:

- Emission Level = Read Level + Antenna Factor + Cable Loss - Preamp Factor
Margin value = Emission level – Limit value
- 5580 MHz: Fundamental Frequency
- *: Out of Restricted Band

| EUT Test Condition | | Measurement Detail | |
|--------------------------|--------------------|--------------------|---------------------------|
| Channel | Channel 140 | Frequency Range | 1 GHz ~ 40 GHz |
| Input Power | 120 Vac, 60 Hz | Detector Function | Peak (PK) Average (AV) |
| Environmental Conditions | 25 deg. C, 65 % RH | Tested By | Charles Hsiao |

| Antenna Polarity & Test Distance: Horizontal at 3 m | | | | | | | | | | |
|---|-------------------------|-------------------|----------------|-------------|-----------------------|-----------------|--------------------|---------------------|----------------------|---------|
| Frequency (MHz) | Emission Level (dBuV/m) | Read Level (dBuV) | Limit (dBuV/m) | Margin (dB) | Antenna Factor (dB/m) | Cable Loss (dB) | Preamp Factor (dB) | Antenna Height (cm) | Table Angle (Degree) | Remark |
| 5700 | 100.65 | 91.52 | | | 34.59 | 8.64 | 34.1 | 224 | 70 | Average |
| 5700 | 107.44 | 98.31 | | | 34.59 | 8.64 | 34.1 | 224 | 70 | Peak |
| *5724.36 | 47.09 | 37.93 | 54 | -6.91 | 34.62 | 8.65 | 34.11 | 224 | 70 | Average |
| *5725.8 | 57.15 | 47.99 | 74 | -16.85 | 34.62 | 8.65 | 34.11 | 224 | 70 | Peak |
| 11400 | 46.8 | 31.7 | 54 | -7.2 | 37.84 | 12.67 | 35.41 | 171 | 240 | Average |
| 11400 | 57.08 | 41.98 | 74 | -16.92 | 37.84 | 12.67 | 35.41 | 171 | 240 | Peak |
| Antenna Polarity & Test Distance: Vertical at 3 m | | | | | | | | | | |
| Frequency (MHz) | Emission Level (dBuV/m) | Read Level (dBuV) | Limit (dBuV/m) | Margin (dB) | Antenna Factor (dB/m) | Cable Loss (dB) | Preamp Factor (dB) | Antenna Height (cm) | Table Angle (Degree) | Remark |
| 5700 | 96.77 | 87.64 | | | 34.59 | 8.64 | 34.1 | 119 | 107 | Average |
| 5700 | 103.56 | 94.43 | | | 34.59 | 8.64 | 34.1 | 119 | 107 | Peak |
| *5724.6 | 55.7 | 46.54 | 74 | -18.3 | 34.62 | 8.65 | 34.11 | 119 | 107 | Peak |
| *5724.76 | 45.46 | 36.3 | 54 | -8.54 | 34.62 | 8.65 | 34.11 | 119 | 107 | Average |
| 11400 | 47 | 31.9 | 54 | -7 | 37.84 | 12.67 | 35.41 | 134 | 147 | Average |
| 11400 | 57.15 | 42.05 | 74 | -16.85 | 37.84 | 12.67 | 35.41 | 134 | 147 | Peak |

Remarks:

- Emission Level = Read Level + Antenna Factor + Cable Loss - Preamp Factor
Margin value = Emission level – Limit value
- 5700 MHz: Fundamental Frequency
- *: Out of Restricted Band

| EUT Test Condition | | Measurement Detail | |
|--------------------------|--------------------|--------------------|---------------------------|
| Channel | Channel 149 | Frequency Range | 1 GHz ~ 40 GHz |
| Input Power | 120 Vac, 60 Hz | Detector Function | Peak (PK) Average (AV) |
| Environmental Conditions | 25 deg. C, 65 % RH | Tested By | Charles Hsiao |

<Spurious Emission>

| Antenna Polarity & Test Distance: Horizontal at 3 m | | | | | | | | | | |
|---|-------------------------|-------------------|----------------|-------------|-----------------------|-----------------|--------------------|---------------------|----------------------|---------|
| Frequency (MHz) | Emission Level (dBuV/m) | Read Level (dBuV) | Limit (dBuV/m) | Margin (dB) | Antenna Factor (dB/m) | Cable Loss (dB) | Preamp Factor (dB) | Antenna Height (cm) | Table Angle (Degree) | Remark |
| 5745 | 100.37 | 91.18 | | | 34.64 | 8.66 | 34.11 | 202 | 299 | Average |
| 5745 | 108.51 | 99.32 | | | 34.64 | 8.66 | 34.11 | 202 | 299 | Peak |
| 11490 | 48.17 | 33.05 | 54 | -5.83 | 37.89 | 12.62 | 35.39 | 147 | 340 | Average |
| 11490 | 57.33 | 42.21 | 74 | -16.67 | 37.89 | 12.62 | 35.39 | 147 | 340 | Peak |
| Antenna Polarity & Test Distance: Vertical at 3 m | | | | | | | | | | |
| Frequency (MHz) | Emission Level (dBuV/m) | Read Level (dBuV) | Limit (dBuV/m) | Margin (dB) | Antenna Factor (dB/m) | Cable Loss (dB) | Preamp Factor (dB) | Antenna Height (cm) | Table Angle (Degree) | Remark |
| 5745 | 94.98 | 85.79 | | | 34.64 | 8.66 | 34.11 | 126 | 354 | Average |
| 5745 | 102.62 | 93.43 | | | 34.64 | 8.66 | 34.11 | 126 | 354 | Peak |
| 11490 | 47.68 | 32.56 | 54 | -6.32 | 37.89 | 12.62 | 35.39 | 157 | 108 | Average |
| 11490 | 56.79 | 41.67 | 74 | -17.21 | 37.89 | 12.62 | 35.39 | 157 | 108 | Peak |

<Out of Band Emission (OOBE)>

| Antenna Polarity & Test Distance: Horizontal at 3 m | | | | | | | | | | |
|---|-------------------------|-------------------|----------------|-------------|-----------------------|-----------------|--------------------|---------------------|----------------------|---------|
| Frequency (MHz) | Emission Level (dBuV/m) | Read Level (dBuV) | Limit (dBuV/m) | Margin (dB) | Antenna Factor (dB/m) | Cable Loss (dB) | Preamp Factor (dB) | Antenna Height (cm) | Table Angle (Degree) | Remark |
| *5598.175 | 44.75 | 35.74 | 54 | -9.25 | 34.49 | 8.6 | 34.08 | 202 | 299 | Average |
| *5598.175 | 55.01 | 46 | 74 | -18.99 | 34.49 | 8.6 | 34.08 | 202 | 299 | Peak |
| 5652.775 | 53.42 | 44.32 | 75.73 | -22.31 | 34.56 | 8.63 | 34.09 | 202 | 299 | Peak |
| 5923.675 | 52.67 | 43.27 | 74.83 | -22.16 | 34.83 | 8.73 | 34.16 | 202 | 299 | Peak |
| *5958.325 | 45.33 | 35.88 | 54 | -8.67 | 34.87 | 8.74 | 34.16 | 202 | 299 | Average |
| *5958.325 | 54.93 | 45.48 | 74 | -19.07 | 34.87 | 8.74 | 34.16 | 202 | 299 | Peak |
| Antenna Polarity & Test Distance: Vertical at 3 m | | | | | | | | | | |
| Frequency (MHz) | Emission Level (dBuV/m) | Read Level (dBuV) | Limit (dBuV/m) | Margin (dB) | Antenna Factor (dB/m) | Cable Loss (dB) | Preamp Factor (dB) | Antenna Height (cm) | Table Angle (Degree) | Remark |
| *5603.95 | 44.99 | 35.96 | 54 | -9.01 | 34.5 | 8.61 | 34.08 | 126 | 354 | Average |
| *5603.95 | 54.15 | 45.12 | 74 | -19.85 | 34.5 | 8.61 | 34.08 | 126 | 354 | Peak |
| 5651.725 | 53.05 | 43.96 | 75.08 | -22.03 | 34.56 | 8.62 | 34.09 | 126 | 354 | Peak |
| 5923.15 | 53.61 | 44.21 | 75.15 | -21.54 | 34.83 | 8.73 | 34.16 | 126 | 354 | Peak |
| *6004.525 | 45.35 | 35.86 | 54 | -8.65 | 34.9 | 8.76 | 34.17 | 126 | 354 | Average |
| *6004.525 | 54.51 | 45.02 | 74 | -19.49 | 34.9 | 8.76 | 34.17 | 126 | 354 | Peak |

Remarks:

- Emission Level = Read Level + Antenna Factor + Cable Loss - Preamp Factor
Margin value = Emission level – Limit value
- 5745 MHz: Fundamental Frequency
- *: Out of Restricted Band

| EUT Test Condition | | Measurement Detail | |
|--------------------------|--------------------|--------------------|---------------------------|
| Channel | Channel 157 | Frequency Range | 1 GHz ~ 40 GHz |
| Input Power | 120 Vac, 60 Hz | Detector Function | Peak (PK) Average (AV) |
| Environmental Conditions | 25 deg. C, 65 % RH | Tested By | Charles Hsiao |

<Spurious Emission>

| Antenna Polarity & Test Distance: Horizontal at 3 m | | | | | | | | | | |
|---|-------------------------|-------------------|----------------|-------------|-----------------------|-----------------|--------------------|---------------------|----------------------|---------|
| Frequency (MHz) | Emission Level (dBuV/m) | Read Level (dBuV) | Limit (dBuV/m) | Margin (dB) | Antenna Factor (dB/m) | Cable Loss (dB) | Preamp Factor (dB) | Antenna Height (cm) | Table Angle (Degree) | Remark |
| 5785 | 100.48 | 91.25 | | | 34.68 | 8.68 | 34.13 | 202 | 299 | Average |
| 5785 | 108.65 | 99.42 | | | 34.68 | 8.68 | 34.13 | 202 | 299 | Peak |
| 11570 | 48.27 | 32.96 | 54 | -5.73 | 38 | 12.68 | 35.37 | 139 | 127 | Average |
| 11570 | 57.26 | 41.95 | 74 | -16.74 | 38 | 12.68 | 35.37 | 139 | 127 | Peak |
| Antenna Polarity & Test Distance: Vertical at 3 m | | | | | | | | | | |
| Frequency (MHz) | Emission Level (dBuV/m) | Read Level (dBuV) | Limit (dBuV/m) | Margin (dB) | Antenna Factor (dB/m) | Cable Loss (dB) | Preamp Factor (dB) | Antenna Height (cm) | Table Angle (Degree) | Remark |
| 5785 | 94.94 | 85.71 | | | 34.68 | 8.68 | 34.13 | 126 | 354 | Average |
| 5785 | 102.86 | 93.63 | | | 34.68 | 8.68 | 34.13 | 126 | 354 | Peak |
| 11570 | 48.01 | 32.7 | 54 | -5.99 | 38 | 12.68 | 35.37 | 128 | 169 | Average |
| 11570 | 57.15 | 41.84 | 74 | -16.85 | 38 | 12.68 | 35.37 | 128 | 169 | Peak |

<Out of Band Emission (OOBE)>

| Antenna Polarity & Test Distance: Horizontal at 3 m | | | | | | | | | | |
|---|-------------------------|-------------------|----------------|-------------|-----------------------|-----------------|--------------------|---------------------|----------------------|---------|
| Frequency (MHz) | Emission Level (dBuV/m) | Read Level (dBuV) | Limit (dBuV/m) | Margin (dB) | Antenna Factor (dB/m) | Cable Loss (dB) | Preamp Factor (dB) | Antenna Height (cm) | Table Angle (Degree) | Remark |
| *5586.1 | 45.81 | 36.8 | 54 | -8.19 | 34.49 | 8.6 | 34.08 | 202 | 299 | Average |
| *5586.1 | 55.09 | 46.08 | 74 | -18.91 | 34.49 | 8.6 | 34.08 | 202 | 299 | Peak |
| 5652.25 | 52.38 | 43.29 | 75.4 | -23.02 | 34.56 | 8.62 | 34.09 | 202 | 299 | Peak |
| 5921.575 | 54.02 | 44.62 | 76.14 | -22.12 | 34.83 | 8.73 | 34.16 | 202 | 299 | Peak |
| *5935.75 | 45.24 | 35.84 | 54 | -8.76 | 34.83 | 8.73 | 34.16 | 202 | 299 | Average |
| *5935.75 | 54.61 | 45.21 | 74 | -19.39 | 34.83 | 8.73 | 34.16 | 202 | 299 | Peak |
| Antenna Polarity & Test Distance: Vertical at 3 m | | | | | | | | | | |
| Frequency (MHz) | Emission Level (dBuV/m) | Read Level (dBuV) | Limit (dBuV/m) | Margin (dB) | Antenna Factor (dB/m) | Cable Loss (dB) | Preamp Factor (dB) | Antenna Height (cm) | Table Angle (Degree) | Remark |
| *5608.15 | 44.75 | 35.72 | 54 | -9.25 | 34.5 | 8.61 | 34.08 | 126 | 354 | Average |
| *5608.15 | 53.87 | 44.84 | 74 | -20.13 | 34.5 | 8.61 | 34.08 | 126 | 354 | Peak |
| 5652.25 | 51.81 | 42.72 | 75.4 | -23.59 | 34.56 | 8.62 | 34.09 | 126 | 354 | Peak |
| 5922.1 | 53.77 | 44.37 | 75.81 | -22.04 | 34.83 | 8.73 | 34.16 | 126 | 354 | Peak |
| *5969.875 | 44.82 | 35.37 | 54 | -9.18 | 34.87 | 8.75 | 34.17 | 126 | 354 | Average |
| *5969.875 | 53.76 | 44.31 | 74 | -20.24 | 34.87 | 8.75 | 34.17 | 126 | 354 | Peak |

Remarks:

- Emission Level = Read Level + Antenna Factor + Cable Loss - Preamp Factor
Margin value = Emission level – Limit value
- 5785 MHz: Fundamental Frequency
- *: Out of Restricted Band

| EUT Test Condition | | Measurement Detail | |
|--------------------------|--------------------|--------------------|---------------------------|
| Channel | Channel 165 | Frequency Range | 1 GHz ~ 40 GHz |
| Input Power | 120 Vac, 60 Hz | Detector Function | Peak (PK) Average (AV) |
| Environmental Conditions | 25 deg. C, 65 % RH | Tested By | Charles Hsiao |

<Spurious Emission>

| Antenna Polarity & Test Distance: Horizontal at 3 m | | | | | | | | | | |
|---|-------------------------|-------------------|----------------|-------------|-----------------------|-----------------|--------------------|---------------------|----------------------|---------|
| Frequency (MHz) | Emission Level (dBuV/m) | Read Level (dBuV) | Limit (dBuV/m) | Margin (dB) | Antenna Factor (dB/m) | Cable Loss (dB) | Preamp Factor (dB) | Antenna Height (cm) | Table Angle (Degree) | Remark |
| 5825 | 100.07 | 90.78 | | | 34.73 | 8.69 | 34.13 | 202 | 299 | Average |
| 5825 | 107.83 | 98.54 | | | 34.73 | 8.69 | 34.13 | 202 | 299 | Peak |
| 11650 | 47.63 | 32.1 | 54 | -6.37 | 38.09 | 12.8 | 35.36 | 156 | 275 | Average |
| 11650 | 56.62 | 41.09 | 74 | -17.38 | 38.09 | 12.8 | 35.36 | 156 | 275 | Peak |
| Antenna Polarity & Test Distance: Vertical at 3 m | | | | | | | | | | |
| Frequency (MHz) | Emission Level (dBuV/m) | Read Level (dBuV) | Limit (dBuV/m) | Margin (dB) | Antenna Factor (dB/m) | Cable Loss (dB) | Preamp Factor (dB) | Antenna Height (cm) | Table Angle (Degree) | Remark |
| 5825 | 96.07 | 86.78 | | | 34.73 | 8.69 | 34.13 | 126 | 354 | Average |
| 5825 | 103.76 | 94.47 | | | 34.73 | 8.69 | 34.13 | 126 | 354 | Peak |
| 11650 | 48.06 | 32.53 | 54 | -5.94 | 38.09 | 12.8 | 35.36 | 196 | 157 | Average |
| 11650 | 58.94 | 43.41 | 74 | -15.06 | 38.09 | 12.8 | 35.36 | 196 | 157 | Peak |

<Out of Band Emission (OOBE)>

| Antenna Polarity & Test Distance: Horizontal at 3 m | | | | | | | | | | |
|---|-------------------------|-------------------|----------------|-------------|-----------------------|-----------------|--------------------|---------------------|----------------------|---------|
| Frequency (MHz) | Emission Level (dBuV/m) | Read Level (dBuV) | Limit (dBuV/m) | Margin (dB) | Antenna Factor (dB/m) | Cable Loss (dB) | Preamp Factor (dB) | Antenna Height (cm) | Table Angle (Degree) | Remark |
| *5638.075 | 45.38 | 36.31 | 54 | -8.62 | 34.54 | 8.62 | 34.09 | 202 | 299 | Average |
| *5638.075 | 54.84 | 45.77 | 74 | -19.16 | 34.54 | 8.62 | 34.09 | 202 | 299 | Peak |
| 5652.25 | 54.76 | 45.67 | 75.4 | -20.64 | 34.56 | 8.62 | 34.09 | 202 | 299 | Peak |
| 5923.675 | 54.83 | 45.43 | 74.83 | -20 | 34.83 | 8.73 | 34.16 | 202 | 299 | Peak |
| *5947.825 | 45.29 | 35.86 | 54 | -8.71 | 34.85 | 8.74 | 34.16 | 202 | 299 | Average |
| *5947.825 | 54.58 | 45.15 | 74 | -19.42 | 34.85 | 8.74 | 34.16 | 202 | 299 | Peak |
| Antenna Polarity & Test Distance: Vertical at 3 m | | | | | | | | | | |
| Frequency (MHz) | Emission Level (dBuV/m) | Read Level (dBuV) | Limit (dBuV/m) | Margin (dB) | Antenna Factor (dB/m) | Cable Loss (dB) | Preamp Factor (dB) | Antenna Height (cm) | Table Angle (Degree) | Remark |
| *5617.075 | 45.82 | 36.77 | 54 | -8.18 | 34.52 | 8.61 | 34.08 | 126 | 354 | Average |
| *5617.075 | 54.99 | 45.94 | 74 | -19.01 | 34.52 | 8.61 | 34.08 | 126 | 354 | Peak |
| 5652.775 | 53.09 | 43.99 | 75.73 | -22.64 | 34.56 | 8.63 | 34.09 | 126 | 354 | Peak |
| 5921.05 | 54.42 | 45.04 | 76.46 | -22.04 | 34.81 | 8.73 | 34.16 | 126 | 354 | Peak |
| *5995.075 | 45.71 | 36.22 | 54 | -8.29 | 34.9 | 8.76 | 34.17 | 126 | 354 | Average |
| *5995.075 | 54.87 | 45.38 | 74 | -19.13 | 34.9 | 8.76 | 34.17 | 126 | 354 | Peak |

Remarks:

- Emission Level = Read Level + Antenna Factor + Cable Loss - Preamp Factor
Margin value = Emission level – Limit value
- 5825 MHz: Fundamental Frequency
- *: Out of Restricted Band

802.11n (HT40)

| EUT Test Condition | | Measurement Detail | |
|--------------------------|--------------------|--------------------|---------------------------|
| Channel | Channel 38 | Frequency Range | 1 GHz ~ 40 GHz |
| Input Power | 120 Vac, 60 Hz | Detector Function | Peak (PK) Average (AV) |
| Environmental Conditions | 25 deg. C, 65 % RH | Tested By | Charles Hsiao |

Antenna Polarity & Test Distance: Horizontal at 3 m

| Frequency (MHz) | Emission Level (dBuV/m) | Read Level (dBuV) | Limit (dBuV/m) | Margin (dB) | Antenna Factor (dB/m) | Cable Loss (dB) | Preamp Factor (dB) | Antenna Height (cm) | Table Angle (Degree) | Remark |
|-----------------|-------------------------|-------------------|----------------|-------------|-----------------------|-----------------|--------------------|---------------------|----------------------|---------|
| 5148.65 | 61.03 | 52.78 | 74 | -12.97 | 34.12 | 8.13 | 34 | 235 | 69 | Peak |
| 5149.7 | 51.64 | 43.39 | 54 | -2.36 | 34.12 | 8.13 | 34 | 235 | 69 | Average |
| 5190 | 96.48 | 88.14 | | | 34.15 | 8.19 | 34 | 235 | 69 | Average |
| 5190 | 103.62 | 95.28 | | | 34.15 | 8.19 | 34 | 235 | 69 | Peak |
| 5372.33 | 54.02 | 45.35 | 74 | -19.98 | 34.29 | 8.41 | 34.03 | 235 | 69 | Peak |
| 5435.58 | 43.71 | 34.92 | 54 | -10.29 | 34.35 | 8.48 | 34.04 | 235 | 69 | Average |

Antenna Polarity & Test Distance: Vertical at 3 m

| Frequency (MHz) | Emission Level (dBuV/m) | Read Level (dBuV) | Limit (dBuV/m) | Margin (dB) | Antenna Factor (dB/m) | Cable Loss (dB) | Preamp Factor (dB) | Antenna Height (cm) | Table Angle (Degree) | Remark |
|-----------------|-------------------------|-------------------|----------------|-------------|-----------------------|-----------------|--------------------|---------------------|----------------------|---------|
| 5148.5 | 58.92 | 50.67 | 74 | -15.08 | 34.12 | 8.13 | 34 | 106 | 96 | Peak |
| 5150 | 49.42 | 41.17 | 54 | -4.58 | 34.12 | 8.13 | 34 | 106 | 96 | Average |
| 5190 | 92.33 | 83.99 | | | 34.15 | 8.19 | 34 | 106 | 96 | Average |
| 5190 | 99.68 | 91.34 | | | 34.15 | 8.19 | 34 | 106 | 96 | Peak |
| 5361.88 | 53.92 | 45.28 | 74 | -20.08 | 34.29 | 8.38 | 34.03 | 106 | 96 | Peak |
| 5393.23 | 43.64 | 34.93 | 54 | -10.36 | 34.31 | 8.44 | 34.04 | 106 | 96 | Average |

Remarks:

- Emission Level = Read Level + Antenna Factor + Cable Loss - Preamp Factor
Margin value = Emission level – Limit value
- 5190 MHz: Fundamental Frequency

| EUT Test Condition | | Measurement Detail | |
|--------------------------|--------------------|--------------------|---------------------------|
| Channel | Channel 46 | Frequency Range | 1 GHz ~ 40 GHz |
| Input Power | 120 Vac, 60 Hz | Detector Function | Peak (PK) Average (AV) |
| Environmental Conditions | 25 deg. C, 65 % RH | Tested By | Charles Hsiao |

| Antenna Polarity & Test Distance: Horizontal at 3 m | | | | | | | | | | |
|---|-------------------------|-------------------|----------------|-------------|-----------------------|-----------------|--------------------|---------------------|----------------------|---------|
| Frequency (MHz) | Emission Level (dBuV/m) | Read Level (dBuV) | Limit (dBuV/m) | Margin (dB) | Antenna Factor (dB/m) | Cable Loss (dB) | Preamp Factor (dB) | Antenna Height (cm) | Table Angle (Degree) | Remark |
| 5146.1 | 54.05 | 45.8 | 74 | -19.95 | 34.12 | 8.13 | 34 | 235 | 69 | Peak |
| 5146.7 | 44.35 | 36.1 | 54 | -9.65 | 34.12 | 8.13 | 34 | 235 | 69 | Average |
| 5230 | 96.69 | 88.29 | | | 34.19 | 8.22 | 34.01 | 235 | 69 | Average |
| 5230 | 103.5 | 95.1 | | | 34.19 | 8.22 | 34.01 | 235 | 69 | Peak |
| 5351.76 | 44.35 | 35.72 | 54 | -9.65 | 34.28 | 8.38 | 34.03 | 235 | 69 | Average |
| 5364.63 | 55.26 | 46.62 | 74 | -18.74 | 34.29 | 8.38 | 34.03 | 235 | 69 | Peak |

| Antenna Polarity & Test Distance: Vertical at 3 m | | | | | | | | | | |
|---|-------------------------|-------------------|----------------|-------------|-----------------------|-----------------|--------------------|---------------------|----------------------|---------|
| Frequency (MHz) | Emission Level (dBuV/m) | Read Level (dBuV) | Limit (dBuV/m) | Margin (dB) | Antenna Factor (dB/m) | Cable Loss (dB) | Preamp Factor (dB) | Antenna Height (cm) | Table Angle (Degree) | Remark |
| 5146.85 | 54.07 | 45.82 | 74 | -19.93 | 34.12 | 8.13 | 34 | 106 | 96 | Peak |
| 5148.8 | 43.47 | 35.22 | 54 | -10.53 | 34.12 | 8.13 | 34 | 106 | 96 | Average |
| 5230 | 92.22 | 83.82 | | | 34.19 | 8.22 | 34.01 | 106 | 96 | Average |
| 5230 | 99.52 | 91.12 | | | 34.19 | 8.22 | 34.01 | 106 | 96 | Peak |
| 5365.62 | 54.45 | 45.81 | 74 | -19.55 | 34.29 | 8.38 | 34.03 | 106 | 96 | Peak |
| 5449.77 | 43.65 | 34.83 | 54 | -10.35 | 34.36 | 8.51 | 34.05 | 106 | 96 | Average |

Remarks:

- Emission Level = Read Level + Antenna Factor + Cable Loss - Preamp Factor
Margin value = Emission level – Limit value
- 5230 MHz: Fundamental Frequency

| EUT Test Condition | | Measurement Detail | |
|--------------------------|--------------------|--------------------|---------------------------|
| Channel | Channel 54 | Frequency Range | 1 GHz ~ 40 GHz |
| Input Power | 120 Vac, 60 Hz | Detector Function | Peak (PK) Average (AV) |
| Environmental Conditions | 25 deg. C, 65 % RH | Tested By | Charles Hsiao |

| Antenna Polarity & Test Distance: Horizontal at 3 m | | | | | | | | | | |
|---|-------------------------|-------------------|----------------|-------------|-----------------------|-----------------|--------------------|---------------------|----------------------|---------|
| Frequency (MHz) | Emission Level (dBuV/m) | Read Level (dBuV) | Limit (dBuV/m) | Margin (dB) | Antenna Factor (dB/m) | Cable Loss (dB) | Preamp Factor (dB) | Antenna Height (cm) | Table Angle (Degree) | Remark |
| 5080.7 | 54.21 | 46.09 | 74 | -19.79 | 34.07 | 8.03 | 33.98 | 198 | 304 | Peak |
| 5146.1 | 43 | 34.75 | 54 | -11 | 34.12 | 8.13 | 34 | 198 | 304 | Average |
| 5270 | 96.16 | 87.67 | | | 34.21 | 8.29 | 34.01 | 198 | 304 | Average |
| 5270 | 104.49 | 96 | | | 34.21 | 8.29 | 34.01 | 198 | 304 | Peak |
| 5351.43 | 44.78 | 36.15 | 54 | -9.22 | 34.28 | 8.38 | 34.03 | 198 | 304 | Average |
| 5362.54 | 54.48 | 45.84 | 74 | -19.52 | 34.29 | 8.38 | 34.03 | 198 | 304 | Peak |

| Antenna Polarity & Test Distance: Vertical at 3 m | | | | | | | | | | |
|---|-------------------------|-------------------|----------------|-------------|-----------------------|-----------------|--------------------|---------------------|----------------------|---------|
| Frequency (MHz) | Emission Level (dBuV/m) | Read Level (dBuV) | Limit (dBuV/m) | Margin (dB) | Antenna Factor (dB/m) | Cable Loss (dB) | Preamp Factor (dB) | Antenna Height (cm) | Table Angle (Degree) | Remark |
| 5102.75 | 42.79 | 34.63 | 54 | -11.21 | 34.08 | 8.07 | 33.99 | 123 | 289 | Average |
| 5135.45 | 53.37 | 45.12 | 74 | -20.63 | 34.11 | 8.13 | 33.99 | 123 | 289 | Peak |
| 5270 | 91.03 | 82.54 | | | 34.21 | 8.29 | 34.01 | 123 | 289 | Average |
| 5270 | 98.99 | 90.5 | | | 34.21 | 8.29 | 34.01 | 123 | 289 | Peak |
| 5403.35 | 54.3 | 45.58 | 74 | -19.7 | 34.32 | 8.44 | 34.04 | 123 | 289 | Peak |
| 5448.89 | 43.24 | 34.41 | 54 | -10.76 | 34.36 | 8.51 | 34.04 | 123 | 289 | Average |

Remarks:

- Emission Level = Read Level + Antenna Factor + Cable Loss - Preamp Factor
Margin value = Emission level – Limit value
- 5270 MHz: Fundamental Frequency

| EUT Test Condition | | Measurement Detail | |
|--------------------------|--------------------|--------------------|---------------------------|
| Channel | Channel 62 | Frequency Range | 1 GHz ~ 40 GHz |
| Input Power | 120 Vac, 60 Hz | Detector Function | Peak (PK) Average (AV) |
| Environmental Conditions | 25 deg. C, 65 % RH | Tested By | Charles Hsiao |

| Antenna Polarity & Test Distance: Horizontal at 3 m | | | | | | | | | | |
|---|-------------------------|-------------------|----------------|-------------|-----------------------|-----------------|--------------------|---------------------|----------------------|---------|
| Frequency (MHz) | Emission Level (dBuV/m) | Read Level (dBuV) | Limit (dBuV/m) | Margin (dB) | Antenna Factor (dB/m) | Cable Loss (dB) | Preamp Factor (dB) | Antenna Height (cm) | Table Angle (Degree) | Remark |
| 5053.1 | 53.9 | 45.84 | 74 | -20.1 | 34.04 | 8 | 33.98 | 198 | 304 | Peak |
| 5132.75 | 42.83 | 34.61 | 54 | -11.17 | 34.11 | 8.1 | 33.99 | 198 | 304 | Average |
| 5310 | 96.91 | 88.36 | | | 34.25 | 8.32 | 34.02 | 198 | 304 | Average |
| 5310 | 104.18 | 95.63 | | | 34.25 | 8.32 | 34.02 | 198 | 304 | Peak |
| 5350.33 | 50.44 | 41.81 | 54 | -3.56 | 34.28 | 8.38 | 34.03 | 198 | 304 | Average |
| 5351.65 | 59.75 | 51.12 | 74 | -14.25 | 34.28 | 8.38 | 34.03 | 198 | 304 | Peak |

| Antenna Polarity & Test Distance: Vertical at 3 m | | | | | | | | | | |
|---|-------------------------|-------------------|----------------|-------------|-----------------------|-----------------|--------------------|---------------------|----------------------|---------|
| Frequency (MHz) | Emission Level (dBuV/m) | Read Level (dBuV) | Limit (dBuV/m) | Margin (dB) | Antenna Factor (dB/m) | Cable Loss (dB) | Preamp Factor (dB) | Antenna Height (cm) | Table Angle (Degree) | Remark |
| 5068.7 | 53.23 | 45.13 | 74 | -20.77 | 34.05 | 8.03 | 33.98 | 123 | 289 | Peak |
| 5101.55 | 42.72 | 34.56 | 54 | -11.28 | 34.08 | 8.07 | 33.99 | 123 | 289 | Average |
| 5310 | 90.8 | 82.25 | | | 34.25 | 8.32 | 34.02 | 123 | 289 | Average |
| 5310 | 98.47 | 89.92 | | | 34.25 | 8.32 | 34.02 | 123 | 289 | Peak |
| 5350.44 | 44.08 | 35.45 | 54 | -9.92 | 34.28 | 8.38 | 34.03 | 123 | 289 | Average |
| 5351.1 | 54.44 | 45.81 | 74 | -19.56 | 34.28 | 8.38 | 34.03 | 123 | 289 | Peak |

Remarks:

- Emission Level = Read Level + Antenna Factor + Cable Loss - Preamp Factor
Margin value = Emission level – Limit value
- 5310 MHz: Fundamental Frequency

| EUT Test Condition | | Measurement Detail | |
|--------------------------|--------------------|--------------------|---------------------------|
| Channel | Channel 102 | Frequency Range | 1 GHz ~ 40 GHz |
| Input Power | 120 Vac, 60 Hz | Detector Function | Peak (PK) Average (AV) |
| Environmental Conditions | 25 deg. C, 65 % RH | Tested By | Charles Hsiao |

| Antenna Polarity & Test Distance: Horizontal at 3 m | | | | | | | | | | |
|---|-------------------------|-------------------|----------------|-------------|-----------------------|-----------------|--------------------|---------------------|----------------------|---------|
| Frequency (MHz) | Emission Level (dBuV/m) | Read Level (dBuV) | Limit (dBuV/m) | Margin (dB) | Antenna Factor (dB/m) | Cable Loss (dB) | Preamp Factor (dB) | Antenna Height (cm) | Table Angle (Degree) | Remark |
| 5459.76 | 45.29 | 36.47 | 54 | -8.71 | 34.36 | 8.51 | 34.05 | 119 | 107 | Average |
| 5459.76 | 54.37 | 45.55 | 74 | -19.63 | 34.36 | 8.51 | 34.05 | 119 | 107 | Peak |
| *5469.84 | 58.73 | 49.9 | 74 | -15.27 | 34.37 | 8.51 | 34.05 | 119 | 107 | Peak |
| *5470.96 | 49.84 | 40.98 | 54 | -4.16 | 34.37 | 8.54 | 34.05 | 119 | 107 | Average |
| 5510 | 94.44 | 85.53 | | | 34.4 | 8.57 | 34.06 | 119 | 107 | Average |
| 5510 | 101.15 | 92.24 | | | 34.4 | 8.57 | 34.06 | 119 | 107 | Peak |
| *5725.56 | 43.84 | 34.68 | 54 | -10.16 | 34.62 | 8.65 | 34.11 | 119 | 107 | Average |
| *5725.88 | 53.92 | 44.76 | 74 | -20.08 | 34.62 | 8.65 | 34.11 | 119 | 107 | Peak |

| Antenna Polarity & Test Distance: Vertical at 3 m | | | | | | | | | | |
|---|-------------------------|-------------------|----------------|-------------|-----------------------|-----------------|--------------------|---------------------|----------------------|---------|
| Frequency (MHz) | Emission Level (dBuV/m) | Read Level (dBuV) | Limit (dBuV/m) | Margin (dB) | Antenna Factor (dB/m) | Cable Loss (dB) | Preamp Factor (dB) | Antenna Height (cm) | Table Angle (Degree) | Remark |
| 5458.48 | 56.24 | 47.42 | 74 | -17.76 | 34.36 | 8.51 | 34.05 | 224 | 70 | Peak |
| 5459.76 | 46.86 | 38.04 | 54 | -7.14 | 34.36 | 8.51 | 34.05 | 224 | 70 | Average |
| *5470.64 | 52.18 | 43.35 | 54 | -1.82 | 34.37 | 8.51 | 34.05 | 224 | 70 | Average |
| *5470.96 | 61.77 | 52.91 | 74 | -12.23 | 34.37 | 8.54 | 34.05 | 224 | 70 | Peak |
| 5510 | 98.74 | 89.83 | | | 34.4 | 8.57 | 34.06 | 224 | 70 | Average |
| 5510 | 105.36 | 96.45 | | | 34.4 | 8.57 | 34.06 | 224 | 70 | Peak |
| *5724.12 | 53.38 | 44.22 | 74 | -20.62 | 34.62 | 8.65 | 34.11 | 224 | 70 | Peak |
| *5724.6 | 43.6 | 34.44 | 54 | -10.4 | 34.62 | 8.65 | 34.11 | 224 | 70 | Average |

Remarks:

- Emission Level = Read Level + Antenna Factor + Cable Loss - Preamp Factor
Margin value = Emission level – Limit value
- 5510 MHz: Fundamental Frequency
- *: Out of Restricted Band

| EUT Test Condition | | Measurement Detail | |
|--------------------------|--------------------|--------------------|---------------------------|
| Channel | Channel 110 | Frequency Range | 1 GHz ~ 40 GHz |
| Input Power | 120 Vac, 60 Hz | Detector Function | Peak (PK) Average (AV) |
| Environmental Conditions | 25 deg. C, 65 % RH | Tested By | Charles Hsiao |

| Antenna Polarity & Test Distance: Horizontal at 3 m | | | | | | | | | | |
|---|-------------------------|-------------------|----------------|-------------|-----------------------|-----------------|--------------------|---------------------|----------------------|---------|
| Frequency (MHz) | Emission Level (dBuV/m) | Read Level (dBuV) | Limit (dBuV/m) | Margin (dB) | Antenna Factor (dB/m) | Cable Loss (dB) | Preamp Factor (dB) | Antenna Height (cm) | Table Angle (Degree) | Remark |
| 5369.2 | 54.82 | 46.15 | 74 | -19.18 | 34.29 | 8.41 | 34.03 | 224 | 70 | Peak |
| 5459.44 | 44.45 | 35.63 | 54 | -9.55 | 34.36 | 8.51 | 34.05 | 224 | 70 | Average |
| *5468.4 | 54.58 | 45.75 | 74 | -19.42 | 34.37 | 8.51 | 34.05 | 224 | 70 | Peak |
| *5470.32 | 45.09 | 36.26 | 54 | -8.91 | 34.37 | 8.51 | 34.05 | 224 | 70 | Average |
| 5550 | 98.06 | 89.09 | | | 34.45 | 8.59 | 34.07 | 224 | 70 | Average |
| 5550 | 105.52 | 96.55 | | | 34.45 | 8.59 | 34.07 | 224 | 70 | Peak |
| *5724.12 | 44.16 | 35 | 54 | -9.84 | 34.62 | 8.65 | 34.11 | 224 | 70 | Average |
| *5725.56 | 53.91 | 44.75 | 74 | -20.09 | 34.62 | 8.65 | 34.11 | 224 | 70 | Peak |

| Antenna Polarity & Test Distance: Vertical at 3 m | | | | | | | | | | |
|---|-------------------------|-------------------|----------------|-------------|-----------------------|-----------------|--------------------|---------------------|----------------------|---------|
| Frequency (MHz) | Emission Level (dBuV/m) | Read Level (dBuV) | Limit (dBuV/m) | Margin (dB) | Antenna Factor (dB/m) | Cable Loss (dB) | Preamp Factor (dB) | Antenna Height (cm) | Table Angle (Degree) | Remark |
| 5409.68 | 54.14 | 45.42 | 74 | -19.86 | 34.32 | 8.44 | 34.04 | 119 | 107 | Peak |
| 5457.52 | 43.95 | 35.13 | 54 | -10.05 | 34.36 | 8.51 | 34.05 | 119 | 107 | Average |
| *5469.2 | 44.16 | 35.33 | 54 | -9.84 | 34.37 | 8.51 | 34.05 | 119 | 107 | Average |
| *5470.64 | 53.18 | 44.35 | 74 | -20.82 | 34.37 | 8.51 | 34.05 | 119 | 107 | Peak |
| 5550 | 94.22 | 85.25 | | | 34.45 | 8.59 | 34.07 | 119 | 107 | Average |
| 5550 | 101.51 | 92.54 | | | 34.45 | 8.59 | 34.07 | 119 | 107 | Peak |
| *5724.04 | 44.07 | 34.91 | 54 | -9.93 | 34.62 | 8.65 | 34.11 | 119 | 107 | Average |
| *5724.36 | 53.04 | 43.88 | 74 | -20.96 | 34.62 | 8.65 | 34.11 | 119 | 107 | Peak |

Remarks:

- Emission Level = Read Level + Antenna Factor + Cable Loss - Preamp Factor
Margin value = Emission level – Limit value
- 5550 MHz: Fundamental Frequency
- *: Out of Restricted Band

| EUT Test Condition | | Measurement Detail | |
|--------------------------|--------------------|--------------------|---------------------------|
| Channel | Channel 134 | Frequency Range | 1 GHz ~ 40 GHz |
| Input Power | 120 Vac, 60 Hz | Detector Function | Peak (PK) Average (AV) |
| Environmental Conditions | 25 deg. C, 65 % RH | Tested By | Charles Hsiao |

| Antenna Polarity & Test Distance: Horizontal at 3 m | | | | | | | | | | |
|---|-------------------------|-------------------|----------------|-------------|-----------------------|-----------------|--------------------|---------------------|----------------------|---------|
| Frequency (MHz) | Emission Level (dBuV/m) | Read Level (dBuV) | Limit (dBuV/m) | Margin (dB) | Antenna Factor (dB/m) | Cable Loss (dB) | Preamp Factor (dB) | Antenna Height (cm) | Table Angle (Degree) | Remark |
| 5375.76 | 53.55 | 44.89 | 74 | -20.45 | 34.29 | 8.41 | 34.04 | 224 | 70 | Peak |
| 5446.8 | 43.81 | 34.98 | 54 | -10.19 | 34.36 | 8.51 | 34.04 | 224 | 70 | Average |
| *5468.72 | 54.02 | 45.19 | 74 | -19.98 | 34.37 | 8.51 | 34.05 | 224 | 70 | Peak |
| *5469.84 | 43.6 | 34.77 | 54 | -10.4 | 34.37 | 8.51 | 34.05 | 224 | 70 | Average |
| 5670 | 97.9 | 88.8 | | | 34.57 | 8.63 | 34.1 | 224 | 70 | Average |
| 5670 | 104.2 | 95.1 | | | 34.57 | 8.63 | 34.1 | 224 | 70 | Peak |
| *5724.04 | 46.24 | 37.08 | 54 | -7.76 | 34.62 | 8.65 | 34.11 | 224 | 70 | Average |
| *5725.48 | 56.37 | 47.21 | 74 | -17.63 | 34.62 | 8.65 | 34.11 | 224 | 70 | Peak |

| Antenna Polarity & Test Distance: Vertical at 3 m | | | | | | | | | | |
|---|-------------------------|-------------------|----------------|-------------|-----------------------|-----------------|--------------------|---------------------|----------------------|---------|
| Frequency (MHz) | Emission Level (dBuV/m) | Read Level (dBuV) | Limit (dBuV/m) | Margin (dB) | Antenna Factor (dB/m) | Cable Loss (dB) | Preamp Factor (dB) | Antenna Height (cm) | Table Angle (Degree) | Remark |
| 5423.92 | 43.43 | 34.66 | 54 | -10.57 | 34.33 | 8.48 | 34.04 | 119 | 107 | Average |
| 5446.16 | 53.67 | 44.84 | 74 | -20.33 | 34.36 | 8.51 | 34.04 | 119 | 107 | Peak |
| *5468.4 | 43.43 | 34.6 | 54 | -10.57 | 34.37 | 8.51 | 34.05 | 119 | 107 | Average |
| *5469.84 | 52.51 | 43.68 | 74 | -21.49 | 34.37 | 8.51 | 34.05 | 119 | 107 | Peak |
| 5670 | 93.25 | 84.15 | | | 34.57 | 8.63 | 34.1 | 119 | 107 | Average |
| 5670 | 100.37 | 91.27 | | | 34.57 | 8.63 | 34.1 | 119 | 107 | Peak |
| *5723.96 | 54.33 | 45.17 | 74 | -19.67 | 34.62 | 8.65 | 34.11 | 119 | 107 | Peak |
| *5725.24 | 44.87 | 35.71 | 54 | -9.13 | 34.62 | 8.65 | 34.11 | 119 | 107 | Average |

Remarks:

- Emission Level = Read Level + Antenna Factor + Cable Loss - Preamp Factor
Margin value = Emission level – Limit value
- 5670 MHz: Fundamental Frequency
- *: Out of Restricted Band

| EUT Test Condition | | Measurement Detail | |
|--------------------------|--------------------|--------------------|---------------------------|
| Channel | Channel 151 | Frequency Range | 1 GHz ~ 40 GHz |
| Input Power | 120 Vac, 60 Hz | Detector Function | Peak (PK) Average (AV) |
| Environmental Conditions | 25 deg. C, 65 % RH | Tested By | Charles Hsiao |

<Spurious Emission>

| Antenna Polarity & Test Distance: Horizontal at 3 m | | | | | | | | | | |
|---|-------------------------|-------------------|----------------|-------------|-----------------------|-----------------|--------------------|---------------------|----------------------|---------|
| Frequency (MHz) | Emission Level (dBuV/m) | Read Level (dBuV) | Limit (dBuV/m) | Margin (dB) | Antenna Factor (dB/m) | Cable Loss (dB) | Preamp Factor (dB) | Antenna Height (cm) | Table Angle (Degree) | Remark |
| 5755 | 97.38 | 88.17 | | | 34.66 | 8.66 | 34.11 | 202 | 299 | Average |
| 5755 | 104.95 | 95.74 | | | 34.66 | 8.66 | 34.11 | 202 | 299 | Peak |
| 11510 | 47.86 | 32.75 | 54 | -6.14 | 37.9 | 12.6 | 35.39 | 168 | 115 | Average |
| 11510 | 58.05 | 42.94 | 74 | -15.95 | 37.9 | 12.6 | 35.39 | 168 | 115 | Peak |
| Antenna Polarity & Test Distance: Vertical at 3 m | | | | | | | | | | |
| Frequency (MHz) | Emission Level (dBuV/m) | Read Level (dBuV) | Limit (dBuV/m) | Margin (dB) | Antenna Factor (dB/m) | Cable Loss (dB) | Preamp Factor (dB) | Antenna Height (cm) | Table Angle (Degree) | Remark |
| 5755 | 92.12 | 82.91 | | | 34.66 | 8.66 | 34.11 | 126 | 354 | Average |
| 5755 | 99.53 | 90.32 | | | 34.66 | 8.66 | 34.11 | 126 | 354 | Peak |
| 11510 | 48.07 | 32.96 | 54 | -5.93 | 37.9 | 12.6 | 35.39 | 127 | 246 | Average |
| 11510 | 57.63 | 42.52 | 74 | -16.37 | 37.9 | 12.6 | 35.39 | 127 | 246 | Peak |

<Out of Band Emission (OOBE)>

| Antenna Polarity & Test Distance: Horizontal at 3 m | | | | | | | | | | |
|---|-------------------------|-------------------|----------------|-------------|-----------------------|-----------------|--------------------|---------------------|----------------------|---------|
| Frequency (MHz) | Emission Level (dBuV/m) | Read Level (dBuV) | Limit (dBuV/m) | Margin (dB) | Antenna Factor (dB/m) | Cable Loss (dB) | Preamp Factor (dB) | Antenna Height (cm) | Table Angle (Degree) | Remark |
| *5640.7 | 45.33 | 36.26 | 54 | -8.67 | 34.54 | 8.62 | 34.09 | 202 | 299 | Average |
| *5640.7 | 54.52 | 45.45 | 74 | -19.48 | 34.54 | 8.62 | 34.09 | 202 | 299 | Peak |
| 5652.25 | 53.59 | 44.5 | 75.4 | -21.81 | 34.56 | 8.62 | 34.09 | 202 | 299 | Peak |
| 5923.15 | 52.28 | 42.88 | 75.15 | -22.87 | 34.83 | 8.73 | 34.16 | 202 | 299 | Peak |
| *5998.75 | 45.74 | 36.25 | 54 | -8.26 | 34.9 | 8.76 | 34.17 | 202 | 299 | Average |
| *5998.75 | 54.86 | 45.37 | 74 | -19.14 | 34.9 | 8.76 | 34.17 | 202 | 299 | Peak |
| Antenna Polarity & Test Distance: Vertical at 3 m | | | | | | | | | | |
| Frequency (MHz) | Emission Level (dBuV/m) | Read Level (dBuV) | Limit (dBuV/m) | Margin (dB) | Antenna Factor (dB/m) | Cable Loss (dB) | Preamp Factor (dB) | Antenna Height (cm) | Table Angle (Degree) | Remark |
| *5557.75 | 45.23 | 36.26 | 54 | -8.77 | 34.45 | 8.59 | 34.07 | 126 | 354 | Average |
| *5557.75 | 54.18 | 45.21 | 74 | -19.82 | 34.45 | 8.59 | 34.07 | 126 | 354 | Peak |
| 5653.3 | 53.06 | 43.96 | 76.06 | -23 | 34.56 | 8.63 | 34.09 | 126 | 354 | Peak |
| 5921.575 | 52.83 | 43.43 | 76.14 | -23.31 | 34.83 | 8.73 | 34.16 | 126 | 354 | Peak |
| *5964.1 | 45.64 | 36.2 | 54 | -8.36 | 34.87 | 8.74 | 34.17 | 126 | 354 | Average |
| *5964.1 | 54.72 | 45.28 | 74 | -19.28 | 34.87 | 8.74 | 34.17 | 126 | 354 | Peak |

Remarks:

- Emission Level = Read Level + Antenna Factor + Cable Loss - Preamp Factor
Margin value = Emission level – Limit value
- 5755 MHz: Fundamental Frequency
- *: Out of Restricted Band

| EUT Test Condition | | Measurement Detail | |
|--------------------------|--------------------|--------------------|---------------------------|
| Channel | Channel 159 | Frequency Range | 1 GHz ~ 40 GHz |
| Input Power | 120 Vac, 60 Hz | Detector Function | Peak (PK) Average (AV) |
| Environmental Conditions | 25 deg. C, 65 % RH | Tested By | Charles Hsiao |

<Spurious Emission>

| Antenna Polarity & Test Distance: Horizontal at 3 m | | | | | | | | | | |
|---|-------------------------|-------------------|----------------|-------------|-----------------------|-----------------|--------------------|---------------------|----------------------|---------|
| Frequency (MHz) | Emission Level (dBuV/m) | Read Level (dBuV) | Limit (dBuV/m) | Margin (dB) | Antenna Factor (dB/m) | Cable Loss (dB) | Preamp Factor (dB) | Antenna Height (cm) | Table Angle (Degree) | Remark |
| 5795 | 97.51 | 88.27 | | | 34.69 | 8.68 | 34.13 | 202 | 299 | Average |
| 5795 | 104.94 | 95.7 | | | 34.69 | 8.68 | 34.13 | 202 | 299 | Peak |
| 11590 | 47.16 | 31.79 | 54 | -6.84 | 38.02 | 12.72 | 35.37 | 159 | 166 | Average |
| 11590 | 56.19 | 40.82 | 74 | -17.81 | 38.02 | 12.72 | 35.37 | 159 | 166 | Peak |
| Antenna Polarity & Test Distance: Vertical at 3 m | | | | | | | | | | |
| Frequency (MHz) | Emission Level (dBuV/m) | Read Level (dBuV) | Limit (dBuV/m) | Margin (dB) | Antenna Factor (dB/m) | Cable Loss (dB) | Preamp Factor (dB) | Antenna Height (cm) | Table Angle (Degree) | Remark |
| 5795 | 91.82 | 82.58 | | | 34.69 | 8.68 | 34.13 | 126 | 350 | Average |
| 5795 | 99.34 | 90.1 | | | 34.69 | 8.68 | 34.13 | 126 | 350 | Peak |
| 11590 | 47.29 | 31.92 | 54 | -6.71 | 38.02 | 12.72 | 35.37 | 137 | 115 | Average |
| 11590 | 56.45 | 41.08 | 74 | -17.55 | 38.02 | 12.72 | 35.37 | 137 | 115 | Peak |

<Out of Band Emission (OOBE)>

| Antenna Polarity & Test Distance: Horizontal at 3 m | | | | | | | | | | |
|---|-------------------------|-------------------|----------------|-------------|-----------------------|-----------------|--------------------|---------------------|----------------------|---------|
| Frequency (MHz) | Emission Level (dBuV/m) | Read Level (dBuV) | Limit (dBuV/m) | Margin (dB) | Antenna Factor (dB/m) | Cable Loss (dB) | Preamp Factor (dB) | Antenna Height (cm) | Table Angle (Degree) | Remark |
| *5614.975 | 46.03 | 37 | 54 | -7.97 | 34.5 | 8.61 | 34.08 | 202 | 299 | Average |
| *5614.975 | 55.18 | 46.15 | 74 | -18.82 | 34.5 | 8.61 | 34.08 | 202 | 299 | Peak |
| 5652.25 | 54.08 | 44.99 | 75.4 | -21.32 | 34.56 | 8.62 | 34.09 | 202 | 299 | Peak |
| 5922.625 | 53.41 | 44.01 | 75.48 | -22.07 | 34.83 | 8.73 | 34.16 | 202 | 299 | Peak |
| *5980.9 | 45.71 | 36.25 | 54 | -8.29 | 34.88 | 8.75 | 34.17 | 202 | 299 | Average |
| *5980.9 | 55.61 | 46.15 | 74 | -18.39 | 34.88 | 8.75 | 34.17 | 202 | 299 | Peak |
| Antenna Polarity & Test Distance: Vertical at 3 m | | | | | | | | | | |
| Frequency (MHz) | Emission Level (dBuV/m) | Read Level (dBuV) | Limit (dBuV/m) | Margin (dB) | Antenna Factor (dB/m) | Cable Loss (dB) | Preamp Factor (dB) | Antenna Height (cm) | Table Angle (Degree) | Remark |
| *5639.65 | 45.68 | 36.61 | 54 | -8.32 | 34.54 | 8.62 | 34.09 | 126 | 350 | Average |
| *5639.65 | 54.79 | 45.72 | 74 | -19.21 | 34.54 | 8.62 | 34.09 | 126 | 350 | Peak |
| 5652.25 | 53 | 43.91 | 75.4 | -22.4 | 34.56 | 8.62 | 34.09 | 126 | 350 | Peak |
| 5920.525 | 53.91 | 44.53 | 76.79 | -22.88 | 34.81 | 8.73 | 34.16 | 126 | 350 | Peak |
| *5997.7 | 46.17 | 36.68 | 54 | -7.83 | 34.9 | 8.76 | 34.17 | 126 | 350 | Average |
| *5997.7 | 55.31 | 45.82 | 74 | -18.69 | 34.9 | 8.76 | 34.17 | 126 | 350 | Peak |

Remarks:

- Emission Level = Read Level + Antenna Factor + Cable Loss - Preamp Factor
Margin value = Emission level – Limit value
- 5795 MHz: Fundamental Frequency
- *: Out of Restricted Band

802.11ac (VHT80)

| EUT Test Condition | | Measurement Detail | |
|--------------------------|--------------------|--------------------|---------------------------|
| Channel | Channel 42 | Frequency Range | 1 GHz ~ 40 GHz |
| Input Power | 120 Vac, 60 Hz | Detector Function | Peak (PK) Average (AV) |
| Environmental Conditions | 25 deg. C, 65 % RH | Tested By | Charles Hsiao |

Antenna Polarity & Test Distance: Horizontal at 3 m

| Frequency (MHz) | Emission Level (dBuV/m) | Read Level (dBuV) | Limit (dBuV/m) | Margin (dB) | Antenna Factor (dB/m) | Cable Loss (dB) | Preamp Factor (dB) | Antenna Height (cm) | Table Angle (Degree) | Remark |
|-----------------|-------------------------|-------------------|----------------|-------------|-----------------------|-----------------|--------------------|---------------------|----------------------|---------|
| 5138.75 | 61.3 | 53.05 | 74 | -12.7 | 34.11 | 8.13 | 33.99 | 235 | 69 | Peak |
| 5149.55 | 52.51 | 44.26 | 54 | -1.49 | 34.12 | 8.13 | 34 | 235 | 69 | Average |
| 5210 | 93.59 | 85.23 | | | 34.17 | 8.19 | 34 | 235 | 69 | Average |
| 5210 | 100 | 91.64 | | | 34.17 | 8.19 | 34 | 235 | 69 | Peak |
| 5371.23 | 54.09 | 45.42 | 74 | -19.91 | 34.29 | 8.41 | 34.03 | 235 | 69 | Peak |
| 5457.47 | 44.24 | 35.42 | 54 | -9.76 | 34.36 | 8.51 | 34.05 | 235 | 69 | Average |

Antenna Polarity & Test Distance: Vertical at 3 m

| Frequency (MHz) | Emission Level (dBuV/m) | Read Level (dBuV) | Limit (dBuV/m) | Margin (dB) | Antenna Factor (dB/m) | Cable Loss (dB) | Preamp Factor (dB) | Antenna Height (cm) | Table Angle (Degree) | Remark |
|-----------------|-------------------------|-------------------|----------------|-------------|-----------------------|-----------------|--------------------|---------------------|----------------------|---------|
| 5138.3 | 59.89 | 51.64 | 74 | -14.11 | 34.11 | 8.13 | 33.99 | 106 | 96 | Peak |
| 5147.75 | 49.13 | 40.88 | 54 | -4.87 | 34.12 | 8.13 | 34 | 106 | 96 | Average |
| 5210 | 89.04 | 80.68 | | | 34.17 | 8.19 | 34 | 106 | 96 | Average |
| 5210 | 96.21 | 87.85 | | | 34.17 | 8.19 | 34 | 106 | 96 | Peak |
| 5350.22 | 54.28 | 45.65 | 74 | -19.72 | 34.28 | 8.38 | 34.03 | 106 | 96 | Peak |
| 5443.06 | 43.92 | 35.13 | 54 | -10.08 | 34.35 | 8.48 | 34.04 | 106 | 96 | Average |

Remarks:

- Emission Level = Read Level + Antenna Factor + Cable Loss - Preamp Factor
Margin value = Emission level – Limit value
- 5210 MHz: Fundamental Frequency

| EUT Test Condition | | Measurement Detail | |
|--------------------------|--------------------|--------------------|---------------------------|
| Channel | Channel 58 | Frequency Range | 1 GHz ~ 40 GHz |
| Input Power | 120 Vac, 60 Hz | Detector Function | Peak (PK) Average (AV) |
| Environmental Conditions | 25 deg. C, 65 % RH | Tested By | Charles Hsiao |

| Antenna Polarity & Test Distance: Horizontal at 3 m | | | | | | | | | | |
|---|-------------------------|-------------------|----------------|-------------|-----------------------|-----------------|--------------------|---------------------|----------------------|---------|
| Frequency (MHz) | Emission Level (dBuV/m) | Read Level (dBuV) | Limit (dBuV/m) | Margin (dB) | Antenna Factor (dB/m) | Cable Loss (dB) | Preamp Factor (dB) | Antenna Height (cm) | Table Angle (Degree) | Remark |
| 5108.9 | 53.95 | 45.75 | 74 | -20.05 | 34.09 | 8.1 | 33.99 | 123 | 289 | Peak |
| 5127.05 | 43.62 | 35.4 | 54 | -10.38 | 34.11 | 8.1 | 33.99 | 123 | 289 | Average |
| 5290 | 87.51 | 78.98 | | | 34.23 | 8.32 | 34.02 | 123 | 289 | Average |
| 5290 | 95.54 | 87.01 | | | 34.23 | 8.32 | 34.02 | 123 | 289 | Peak |
| 5350 | 60.29 | 51.66 | 74 | -13.71 | 34.28 | 8.38 | 34.03 | 123 | 289 | Peak |
| 5350.11 | 46.81 | 38.18 | 54 | -7.19 | 34.28 | 8.38 | 34.03 | 123 | 289 | Average |

| Antenna Polarity & Test Distance: Vertical at 3 m | | | | | | | | | | |
|---|-------------------------|-------------------|----------------|-------------|-----------------------|-----------------|--------------------|---------------------|----------------------|---------|
| Frequency (MHz) | Emission Level (dBuV/m) | Read Level (dBuV) | Limit (dBuV/m) | Margin (dB) | Antenna Factor (dB/m) | Cable Loss (dB) | Preamp Factor (dB) | Antenna Height (cm) | Table Angle (Degree) | Remark |
| 5102.75 | 53.91 | 45.75 | 74 | -20.09 | 34.08 | 8.07 | 33.99 | 198 | 304 | Peak |
| 5144.9 | 43.8 | 35.55 | 54 | -10.2 | 34.12 | 8.13 | 34 | 198 | 304 | Average |
| 5290 | 93.13 | 84.6 | | | 34.23 | 8.32 | 34.02 | 198 | 304 | Average |
| 5290 | 101.65 | 93.12 | | | 34.23 | 8.32 | 34.02 | 198 | 304 | Peak |
| 5350.11 | 52.92 | 44.29 | 54 | -1.08 | 34.28 | 8.38 | 34.03 | 198 | 304 | Average |
| 5351.32 | 69.05 | 60.42 | 74 | -4.95 | 34.28 | 8.38 | 34.03 | 198 | 304 | Peak |

Remarks:

- Emission Level = Read Level + Antenna Factor + Cable Loss - Preamp Factor
Margin value = Emission level – Limit value
- 5290 MHz: Fundamental Frequency

| EUT Test Condition | | Measurement Detail | |
|--------------------------|--------------------|--------------------|---------------------------|
| Channel | Channel 106 | Frequency Range | 1 GHz ~ 40 GHz |
| Input Power | 120 Vac, 60 Hz | Detector Function | Peak (PK) Average (AV) |
| Environmental Conditions | 25 deg. C, 65 % RH | Tested By | Charles Hsiao |

| Antenna Polarity & Test Distance: Horizontal at 3 m | | | | | | | | | | |
|---|-------------------------|-------------------|----------------|-------------|-----------------------|-----------------|--------------------|---------------------|----------------------|---------|
| Frequency (MHz) | Emission Level (dBuV/m) | Read Level (dBuV) | Limit (dBuV/m) | Margin (dB) | Antenna Factor (dB/m) | Cable Loss (dB) | Preamp Factor (dB) | Antenna Height (cm) | Table Angle (Degree) | Remark |
| 5458.32 | 51.25 | 42.43 | 54 | -2.75 | 34.36 | 8.51 | 34.05 | 224 | 70 | Average |
| 5459.28 | 62.09 | 53.27 | 74 | -11.91 | 34.36 | 8.51 | 34.05 | 224 | 70 | Peak |
| *5468.08 | 63.94 | 55.11 | 74 | -10.06 | 34.37 | 8.51 | 34.05 | 224 | 70 | Peak |
| *5470 | 52.97 | 44.14 | 54 | -1.03 | 34.37 | 8.51 | 34.05 | 224 | 70 | Average |
| 5530 | 95.65 | 86.72 | | | 34.42 | 8.58 | 34.07 | 224 | 70 | Average |
| 5530 | 102.11 | 93.18 | | | 34.42 | 8.58 | 34.07 | 224 | 70 | Peak |
| *5724.84 | 44.4 | 35.24 | 54 | -9.6 | 34.62 | 8.65 | 34.11 | 224 | 70 | Average |
| *5725.16 | 53.53 | 44.37 | 74 | -20.47 | 34.62 | 8.65 | 34.11 | 224 | 70 | Peak |

| Antenna Polarity & Test Distance: Vertical at 3 m | | | | | | | | | | |
|---|-------------------------|-------------------|----------------|-------------|-----------------------|-----------------|--------------------|---------------------|----------------------|---------|
| Frequency (MHz) | Emission Level (dBuV/m) | Read Level (dBuV) | Limit (dBuV/m) | Margin (dB) | Antenna Factor (dB/m) | Cable Loss (dB) | Preamp Factor (dB) | Antenna Height (cm) | Table Angle (Degree) | Remark |
| 5459.76 | 49.65 | 40.83 | 54 | -4.35 | 34.36 | 8.51 | 34.05 | 119 | 107 | Average |
| 5460 | 57.84 | 49.02 | 74 | -16.16 | 34.36 | 8.51 | 34.05 | 119 | 107 | Peak |
| *5468.88 | 59.63 | 50.8 | 74 | -14.37 | 34.37 | 8.51 | 34.05 | 119 | 107 | Peak |
| *5470 | 51.34 | 42.51 | 54 | -2.66 | 34.37 | 8.51 | 34.05 | 119 | 107 | Average |
| 5530 | 91.25 | 82.32 | | | 34.42 | 8.58 | 34.07 | 119 | 107 | Average |
| 5530 | 98.45 | 89.52 | | | 34.42 | 8.58 | 34.07 | 119 | 107 | Peak |
| *5724.92 | 44.25 | 35.09 | 54 | -9.75 | 34.62 | 8.65 | 34.11 | 119 | 107 | Average |
| *5726.04 | 53.48 | 44.32 | 74 | -20.52 | 34.62 | 8.65 | 34.11 | 119 | 107 | Peak |

Remarks:

- Emission Level = Read Level + Antenna Factor + Cable Loss - Preamp Factor
Margin value = Emission level – Limit value
- 5530 MHz: Fundamental Frequency
- *: Out of Restricted Band

| EUT Test Condition | | Measurement Detail | |
|--------------------------|--------------------|--------------------|---------------------------|
| Channel | Channel 122 | Frequency Range | 1 GHz ~ 40 GHz |
| Input Power | 120 Vac, 60 Hz | Detector Function | Peak (PK) Average (AV) |
| Environmental Conditions | 25 deg. C, 65 % RH | Tested By | Charles Hsiao |

| Antenna Polarity & Test Distance: Horizontal at 3 m | | | | | | | | | | |
|---|-------------------------|-------------------|----------------|-------------|-----------------------|-----------------|--------------------|---------------------|----------------------|---------|
| Frequency (MHz) | Emission Level (dBuV/m) | Read Level (dBuV) | Limit (dBuV/m) | Margin (dB) | Antenna Factor (dB/m) | Cable Loss (dB) | Preamp Factor (dB) | Antenna Height (cm) | Table Angle (Degree) | Remark |
| 5455.28 | 53.83 | 45.01 | 74 | -20.17 | 34.36 | 8.51 | 34.05 | 224 | 70 | Peak |
| 5459.76 | 44.17 | 35.35 | 54 | -9.83 | 34.36 | 8.51 | 34.05 | 224 | 70 | Average |
| *5468.08 | 44.29 | 35.46 | 54 | -9.71 | 34.37 | 8.51 | 34.05 | 224 | 70 | Average |
| *5469.2 | 53.15 | 44.32 | 74 | -20.85 | 34.37 | 8.51 | 34.05 | 224 | 70 | Peak |
| 5610 | 94.55 | 85.52 | | | 34.5 | 8.61 | 34.08 | 224 | 70 | Average |
| 5610 | 101.2 | 92.17 | | | 34.5 | 8.61 | 34.08 | 224 | 70 | Peak |
| *5724.12 | 44.85 | 35.69 | 54 | -9.15 | 34.62 | 8.65 | 34.11 | 224 | 70 | Average |
| *5725.72 | 54.36 | 45.2 | 74 | -19.64 | 34.62 | 8.65 | 34.11 | 224 | 70 | Peak |

| Antenna Polarity & Test Distance: Vertical at 3 m | | | | | | | | | | |
|---|-------------------------|-------------------|----------------|-------------|-----------------------|-----------------|--------------------|---------------------|----------------------|---------|
| Frequency (MHz) | Emission Level (dBuV/m) | Read Level (dBuV) | Limit (dBuV/m) | Margin (dB) | Antenna Factor (dB/m) | Cable Loss (dB) | Preamp Factor (dB) | Antenna Height (cm) | Table Angle (Degree) | Remark |
| 5429.52 | 53.87 | 45.08 | 74 | -20.13 | 34.35 | 8.48 | 34.04 | 119 | 107 | Peak |
| 5449.68 | 44.02 | 35.19 | 54 | -9.98 | 34.36 | 8.51 | 34.04 | 119 | 107 | Average |
| *5468.4 | 44.07 | 35.24 | 54 | -9.93 | 34.37 | 8.51 | 34.05 | 119 | 107 | Average |
| *5470.64 | 53.05 | 44.22 | 74 | -20.95 | 34.37 | 8.51 | 34.05 | 119 | 107 | Peak |
| 5610 | 90.47 | 81.44 | | | 34.5 | 8.61 | 34.08 | 119 | 107 | Average |
| 5610 | 97.42 | 88.39 | | | 34.5 | 8.61 | 34.08 | 119 | 107 | Peak |
| *5724.2 | 53.44 | 44.28 | 74 | -20.56 | 34.62 | 8.65 | 34.11 | 119 | 107 | Peak |
| *5724.84 | 44.51 | 35.35 | 54 | -9.49 | 34.62 | 8.65 | 34.11 | 119 | 107 | Average |

Remarks:

- Emission Level = Read Level + Antenna Factor + Cable Loss - Preamp Factor
Margin value = Emission level – Limit value
- 5610 MHz: Fundamental Frequency
- *: Out of Restricted Band

| EUT Test Condition | | Measurement Detail | |
|--------------------------|--------------------|--------------------|---------------------------|
| Channel | Channel 155 | Frequency Range | 1 GHz ~ 40 GHz |
| Input Power | 120 Vac, 60 Hz | Detector Function | Peak (PK) Average (AV) |
| Environmental Conditions | 25 deg. C, 65 % RH | Tested By | Charles Hsiao |

<Spurious Emission>

| Antenna Polarity & Test Distance: Horizontal at 3 m | | | | | | | | | | |
|---|-------------------------|-------------------|----------------|-------------|-----------------------|-----------------|--------------------|---------------------|----------------------|---------|
| Frequency (MHz) | Emission Level (dBuV/m) | Read Level (dBuV) | Limit (dBuV/m) | Margin (dB) | Antenna Factor (dB/m) | Cable Loss (dB) | Preamp Factor (dB) | Antenna Height (cm) | Table Angle (Degree) | Remark |
| 5775 | 95.44 | 86.21 | 54 | 41.44 | 34.68 | 8.67 | 34.12 | 202 | 299 | Average |
| 5775 | 103.6 | 94.37 | 74 | 29.6 | 34.68 | 8.67 | 34.12 | 202 | 299 | Peak |
| 11550 | 47.19 | 31.92 | 54 | -6.81 | 37.97 | 12.68 | 35.38 | 196 | 342 | Average |
| 11550 | 56.56 | 41.29 | 74 | -17.44 | 37.97 | 12.68 | 35.38 | 196 | 342 | Peak |
| Antenna Polarity & Test Distance: Vertical at 3 m | | | | | | | | | | |
| Frequency (MHz) | Emission Level (dBuV/m) | Read Level (dBuV) | Limit (dBuV/m) | Margin (dB) | Antenna Factor (dB/m) | Cable Loss (dB) | Preamp Factor (dB) | Antenna Height (cm) | Table Angle (Degree) | Remark |
| 5775 | 91.11 | 81.88 | 54 | 37.11 | 34.68 | 8.67 | 34.12 | 126 | 354 | Average |
| 5775 | 98.49 | 89.26 | 74 | 24.49 | 34.68 | 8.67 | 34.12 | 126 | 354 | Peak |
| 11550 | 47.58 | 32.31 | 54 | -6.42 | 37.97 | 12.68 | 35.38 | 137 | 168 | Average |
| 11550 | 56.8 | 41.53 | 74 | -17.2 | 37.97 | 12.68 | 35.38 | 137 | 168 | Peak |

<Out of Band Emission (OOBE)>

| Antenna Polarity & Test Distance: Horizontal at 3 m | | | | | | | | | | |
|---|-------------------------|-------------------|----------------|-------------|-----------------------|-----------------|--------------------|---------------------|----------------------|---------|
| Frequency (MHz) | Emission Level (dBuV/m) | Read Level (dBuV) | Limit (dBuV/m) | Margin (dB) | Antenna Factor (dB/m) | Cable Loss (dB) | Preamp Factor (dB) | Antenna Height (cm) | Table Angle (Degree) | Remark |
| *5631.25 | 46.48 | 37.43 | 54 | -7.52 | 34.52 | 8.62 | 34.09 | 202 | 299 | Average |
| *5631.25 | 55.65 | 46.6 | 74 | -18.35 | 34.52 | 8.62 | 34.09 | 202 | 299 | Peak |
| 5653.3 | 54.86 | 45.76 | 76.06 | -21.2 | 34.56 | 8.63 | 34.09 | 202 | 299 | Peak |
| 5923.675 | 53.37 | 43.97 | 74.83 | -21.46 | 34.83 | 8.73 | 34.16 | 202 | 299 | Peak |
| *5997.7 | 45.72 | 36.23 | 54 | -8.28 | 34.9 | 8.76 | 34.17 | 202 | 299 | Average |
| *5997.7 | 54.67 | 45.18 | 74 | -19.33 | 34.9 | 8.76 | 34.17 | 202 | 299 | Peak |
| Antenna Polarity & Test Distance: Vertical at 3 m | | | | | | | | | | |
| Frequency (MHz) | Emission Level (dBuV/m) | Read Level (dBuV) | Limit (dBuV/m) | Margin (dB) | Antenna Factor (dB/m) | Cable Loss (dB) | Preamp Factor (dB) | Antenna Height (cm) | Table Angle (Degree) | Remark |
| *5589.775 | 45.27 | 36.26 | 54 | -8.73 | 34.49 | 8.6 | 34.08 | 126 | 354 | Average |
| *5589.775 | 54.36 | 45.35 | 74 | -19.64 | 34.49 | 8.6 | 34.08 | 126 | 354 | Peak |
| 5651.2 | 52.14 | 43.05 | 74.75 | -22.61 | 34.56 | 8.62 | 34.09 | 126 | 354 | Peak |
| 5923.675 | 52.55 | 43.15 | 74.83 | -22.28 | 34.83 | 8.73 | 34.16 | 126 | 354 | Peak |
| *6015.55 | 45.72 | 36.22 | 54 | -8.28 | 34.92 | 8.76 | 34.18 | 126 | 354 | Average |
| *6015.55 | 54.58 | 45.08 | 74 | -19.42 | 34.92 | 8.76 | 34.18 | 126 | 354 | Peak |

Remarks:

- Emission Level = Read Level + Antenna Factor + Cable Loss - Preamp Factor
Margin value = Emission level – Limit value
- 5775 MHz: Fundamental Frequency
- *: Out of Restricted Band

9 kHz ~ 30 MHz DATA:

The amplitude of spurious emissions attenuated more than 20 dB below the permissible value is not required to be report.

30 MHz ~ 1 GHz WORST-CASE DATA:

802.11ac (VHT80)

| EUT Test Condition | | Measurement Detail | |
|--------------------------|--------------------|--------------------|------------------------------|
| Channel | Channel 42 | Frequency Range | 30 MHz ~ 1 GHz |
| Input Power | 120 Vac, 60 Hz | Detector Function | Peak (PK) Quasi-peak (QP) |
| Environmental Conditions | 25 deg. C, 65 % RH | Tested By | Charles Hsiao |

| Antenna Polarity & Test Distance: Horizontal at 3 m | | | | | | | | | | |
|---|-------------------------|-------------------|----------------|-------------|-----------------------|-----------------|--------------------|---------------------|----------------------|--------|
| Frequency (MHz) | Emission Level (dBuV/m) | Read Level (dBuV) | Limit (dBuV/m) | Margin (dB) | Antenna Factor (dB/m) | Cable Loss (dB) | Preamp Factor (dB) | Antenna Height (cm) | Table Angle (Degree) | Remark |
| 55.38 | 27.9 | 45.09 | 40 | -12.1 | 14.14 | 0.9 | 32.23 | 111 | 154 | Peak |
| 96.42 | 23.19 | 42.2 | 43.5 | -20.31 | 11.75 | 1.28 | 32.04 | 132 | 169 | Peak |
| 181.2 | 26.01 | 46.81 | 43.5 | -17.49 | 9.83 | 1.61 | 32.24 | 157 | 148 | Peak |
| 370 | 15.29 | 30.68 | 46 | -30.71 | 14.48 | 2.26 | 32.13 | 115 | 185 | Peak |
| 539.4 | 17.68 | 30.23 | 46 | -28.32 | 16.87 | 2.76 | 32.18 | 104 | 174 | Peak |
| 776.7 | 21.7 | 30.43 | 46 | -24.3 | 20.1 | 3.27 | 32.1 | 159 | 184 | Peak |

| Antenna Polarity & Test Distance: Vertical at 3 m | | | | | | | | | | |
|---|-------------------------|-------------------|----------------|-------------|-----------------------|-----------------|--------------------|---------------------|----------------------|--------|
| Frequency (MHz) | Emission Level (dBuV/m) | Read Level (dBuV) | Limit (dBuV/m) | Margin (dB) | Antenna Factor (dB/m) | Cable Loss (dB) | Preamp Factor (dB) | Antenna Height (cm) | Table Angle (Degree) | Remark |
| 48.36 | 36.93 | 53.69 | 40 | -3.07 | 14.56 | 0.9 | 32.22 | 121 | 215 | Peak |
| 58.35 | 36.22 | 53.87 | 40 | -3.78 | 13.68 | 0.9 | 32.23 | 158 | 184 | Peak |
| 145.02 | 21.06 | 43.58 | 43.5 | -22.44 | 8.37 | 1.38 | 32.27 | 101 | 194 | Peak |
| 333.6 | 13.9 | 29.91 | 46 | -32.1 | 13.89 | 2.19 | 32.09 | 115 | 124 | Peak |
| 628.3 | 19.12 | 30.16 | 46 | -26.88 | 18.2 | 2.93 | 32.17 | 135 | 152 | Peak |
| 746.6 | 21.35 | 30.49 | 46 | -24.65 | 19.78 | 3.22 | 32.14 | 184 | 112 | Peak |

Remarks:

1. Emission Level = Read Level + Antenna Factor + Cable Loss - Preamp Factor

Margin value = Emission level – Limit value

802.11ac (VHT80)

| EUT Test Condition | | Measurement Detail | |
|--------------------------|--------------------|--------------------|------------------------------|
| Channel | Channel 58 | Frequency Range | 30 MHz ~ 1 GHz |
| Input Power | 120 Vac, 60 Hz | Detector Function | Peak (PK) Quasi-peak (QP) |
| Environmental Conditions | 25 deg. C, 65 % RH | Tested By | Charles Hsiao |

Antenna Polarity & Test Distance: Horizontal at 3 m

| Frequency (MHz) | Emission Level (dBuV/m) | Read Level (dBuV) | Limit (dBuV/m) | Margin (dB) | Antenna Factor (dB/m) | Cable Loss (dB) | Preamp Factor (dB) | Antenna Height (cm) | Table Angle (Degree) | Remark |
|-----------------|-------------------------|-------------------|----------------|-------------|-----------------------|-----------------|--------------------|---------------------|----------------------|--------|
| 42.15 | 17.23 | 34.73 | 40 | -22.77 | 13.98 | 0.74 | 32.22 | 152 | 169 | Peak |
| 99.12 | 23.69 | 42.47 | 43.5 | -19.81 | 12.15 | 1.28 | 32.21 | 132 | 145 | Peak |
| 187.68 | 26.55 | 46.74 | 43.5 | -16.95 | 10.45 | 1.61 | 32.25 | 118 | 174 | Peak |
| 372.8 | 14.38 | 29.76 | 46 | -31.62 | 14.5 | 2.26 | 32.14 | 105 | 184 | Peak |
| 658.4 | 19.73 | 30.3 | 46 | -26.27 | 18.58 | 2.99 | 32.14 | 195 | 174 | Peak |
| 808.2 | 21.4 | 29.65 | 46 | -24.6 | 20.45 | 3.32 | 32.02 | 113 | 112 | Peak |

Antenna Polarity & Test Distance: Vertical at 3 m

| Frequency (MHz) | Emission Level (dBuV/m) | Read Level (dBuV) | Limit (dBuV/m) | Margin (dB) | Antenna Factor (dB/m) | Cable Loss (dB) | Preamp Factor (dB) | Antenna Height (cm) | Table Angle (Degree) | Remark |
|-----------------|-------------------------|-------------------|----------------|-------------|-----------------------|-----------------|--------------------|---------------------|----------------------|--------|
| 46.47 | 35.42 | 52.28 | 40 | -4.58 | 14.46 | 0.9 | 32.22 | 200 | 154 | Peak |
| 78.06 | 28.68 | 51.49 | 40 | -11.32 | 8.29 | 1.11 | 32.21 | 102 | 223 | Peak |
| 186.06 | 17.34 | 37.7 | 43.5 | -26.16 | 10.28 | 1.61 | 32.25 | 115 | 169 | Peak |
| 329.4 | 14.13 | 30.25 | 46 | -31.87 | 13.78 | 2.19 | 32.09 | 112 | 165 | Peak |
| 624.8 | 19.08 | 30.15 | 46 | -26.92 | 18.17 | 2.93 | 32.17 | 159 | 145 | Peak |
| 864.2 | 22.34 | 29.41 | 46 | -23.66 | 21.19 | 3.44 | 31.7 | 105 | 214 | Peak |

Remarks:

- Emission Level = Read Level + Antenna Factor + Cable Loss - Preamp Factor
Margin value = Emission level – Limit value

802.11ac (VHT80)

| EUT Test Condition | | Measurement Detail | |
|--------------------------|--------------------|--------------------|------------------------------|
| Channel | Channel 106 | Frequency Range | 30 MHz ~ 1 GHz |
| Input Power | 120 Vac, 60 Hz | Detector Function | Peak (PK) Quasi-peak (QP) |
| Environmental Conditions | 25 deg. C, 65 % RH | Tested By | Charles Hsiao |

Antenna Polarity & Test Distance: Horizontal at 3 m

| Frequency (MHz) | Emission Level (dBuV/m) | Read Level (dBuV) | Limit (dBuV/m) | Margin (dB) | Antenna Factor (dB/m) | Cable Loss (dB) | Preamp Factor (dB) | Antenna Height (cm) | Table Angle (Degree) | Remark |
|-----------------|-------------------------|-------------------|----------------|-------------|-----------------------|-----------------|--------------------|---------------------|----------------------|--------|
| 55.92 | 24.13 | 41.47 | 40 | -15.87 | 13.99 | 0.9 | 32.23 | 115 | 158 | Peak |
| 96.96 | 22.08 | 41.02 | 43.5 | -21.42 | 11.88 | 1.28 | 32.1 | 158 | 221 | Peak |
| 173.91 | 27.11 | 48.42 | 43.5 | -16.39 | 9.32 | 1.61 | 32.24 | 126 | 145 | Peak |
| 399.4 | 14.63 | 29.52 | 46 | -31.37 | 14.99 | 2.34 | 32.22 | 105 | 187 | Peak |
| 645.8 | 19.22 | 30 | 46 | -26.78 | 18.38 | 2.99 | 32.15 | 195 | 165 | Peak |
| 693.4 | 20.75 | 30.6 | 46 | -25.25 | 19.14 | 3.11 | 32.1 | 118 | 194 | Peak |

Antenna Polarity & Test Distance: Vertical at 3 m

| Frequency (MHz) | Emission Level (dBuV/m) | Read Level (dBuV) | Limit (dBuV/m) | Margin (dB) | Antenna Factor (dB/m) | Cable Loss (dB) | Preamp Factor (dB) | Antenna Height (cm) | Table Angle (Degree) | Remark |
|-----------------|-------------------------|-------------------|----------------|-------------|-----------------------|-----------------|--------------------|---------------------|----------------------|--------|
| 53.22 | 36.89 | 53.92 | 40 | -3.11 | 14.3 | 0.9 | 32.23 | 105 | 187 | Peak |
| 64.56 | 28.94 | 48.17 | 40 | -11.06 | 12.09 | 0.9 | 32.22 | 115 | 114 | Peak |
| 173.37 | 14.73 | 36.04 | 43.5 | -28.77 | 9.32 | 1.61 | 32.24 | 118 | 159 | Peak |
| 420.4 | 15.6 | 30.15 | 46 | -30.4 | 15.23 | 2.41 | 32.19 | 188 | 195 | Peak |
| 678.7 | 20.14 | 30.29 | 46 | -25.86 | 18.91 | 3.05 | 32.11 | 105 | 188 | Peak |
| 902.7 | 23.77 | 30.23 | 46 | -22.23 | 21.47 | 3.53 | 31.46 | 132 | 165 | Peak |

Remarks:

- Emission Level = Read Level + Antenna Factor + Cable Loss - Preamp Factor
Margin value = Emission level – Limit value

802.11a

| EUT Test Condition | | Measurement Detail | |
|--------------------------|--------------------|--------------------|------------------------------|
| Channel | Channel 165 | Frequency Range | 30 MHz ~ 1 GHz |
| Input Power | 120 Vac, 60 Hz | Detector Function | Peak (PK) Quasi-peak (QP) |
| Environmental Conditions | 25 deg. C, 65 % RH | Tested By | Charles Hsiao |

Antenna Polarity & Test Distance: Horizontal at 3 m

| Frequency (MHz) | Emission Level (dBuV/m) | Read Level (dBuV) | Limit (dBuV/m) | Margin (dB) | Antenna Factor (dB/m) | Cable Loss (dB) | Preamp Factor (dB) | Antenna Height (cm) | Table Angle (Degree) | Remark |
|-----------------|-------------------------|-------------------|----------------|-------------|-----------------------|-----------------|--------------------|---------------------|----------------------|--------|
| 57 | 18.02 | 35.52 | 40 | -21.98 | 13.83 | 0.9 | 32.23 | 115 | 188 | Peak |
| 102.09 | 22.45 | 41.09 | 43.5 | -21.05 | 12.34 | 1.28 | 32.26 | 199 | 164 | Peak |
| 174.72 | 26.04 | 47.29 | 43.5 | -17.46 | 9.38 | 1.61 | 32.24 | 147 | 184 | Peak |
| 438.6 | 15.62 | 29.89 | 46 | -30.38 | 15.4 | 2.49 | 32.16 | 154 | 184 | Peak |
| 650.7 | 19.5 | 30.2 | 46 | -26.5 | 18.46 | 2.99 | 32.15 | 126 | 174 | Peak |
| 740.3 | 21.01 | 30.27 | 46 | -24.99 | 19.71 | 3.16 | 32.13 | 126 | 194 | Peak |

Antenna Polarity & Test Distance: Vertical at 3 m

| Frequency (MHz) | Emission Level (dBuV/m) | Read Level (dBuV) | Limit (dBuV/m) | Margin (dB) | Antenna Factor (dB/m) | Cable Loss (dB) | Preamp Factor (dB) | Antenna Height (cm) | Table Angle (Degree) | Remark |
|-----------------|-------------------------|-------------------|----------------|-------------|-----------------------|-----------------|--------------------|---------------------|----------------------|--------|
| 56.46 | 35.55 | 52.89 | 40 | -4.45 | 13.99 | 0.9 | 32.23 | 126 | 195 | Peak |
| 76.44 | 30.53 | 53.27 | 40 | -9.47 | 8.37 | 1.11 | 32.22 | 188 | 177 | Peak |
| 122.34 | 18.49 | 39.43 | 43.5 | -25.01 | 9.92 | 1.38 | 32.24 | 153 | 169 | Peak |
| 379.8 | 14.42 | 29.73 | 46 | -31.58 | 14.59 | 2.26 | 32.16 | 146 | 192 | Peak |
| 617.1 | 19.08 | 30.23 | 46 | -26.92 | 18.1 | 2.93 | 32.18 | 184 | 108 | Peak |
| 706 | 20.61 | 30.27 | 46 | -25.39 | 19.32 | 3.11 | 32.09 | 112 | 203 | Peak |

Remarks:

- Emission Level = Read Level + Antenna Factor + Cable Loss - Preamp Factor
Margin value = Emission level – Limit value

4.2 Conducted Emission Measurement

4.2.1 Limits of Conducted Emission Measurement

| Frequency (MHz) | Conducted Limit (dBuV) | |
|-----------------|------------------------|---------|
| | Quasi-peak | Average |
| 0.15 - 0.5 | 66 - 56 | 56 - 46 |
| 0.50 - 5.0 | 56 | 46 |
| 5.0 - 30.0 | 60 | 50 |

Note: 1. The lower limit shall apply at the transition frequencies.

2. The limit decreases in line with the logarithm of the frequency in the range of 0.15 to 0.50 MHz.

4.2.2 Test Instruments

| Description & Manufacturer | Model No. | Serial No. | Date Of Calibration | Due Date Of Calibration |
|---|--------------------------|----------------|---------------------|-------------------------|
| Test Receiver ROHDE & SCHWARZ | ESCI | 100613 | Nov. 21, 2016 | Nov. 20, 2017 |
| RF signal cable (with 10dB PAD) Woken | 5D-FB | Cable-cond1-01 | Dec. 22, 2016 | Dec. 21, 2017 |
| LISN/AMN ROHDE & SCHWARZ (EUT) | ESH3-Z5 | 835239/001 | Mar. 10, 2017 | Mar. 09, 2018 |
| LISN/AMN ROHDE & SCHWARZ (Peripheral) | ESH3-Z5 | 100311 | Jul. 28, 2016 | Jul. 27, 2017 |
| Software ADT | BV ADT_Cond_ V7.3.7.3 | NA | NA | NA |

- Note:**
1. The calibration interval of the above test instruments is 12 months and the calibrations are traceable to NML/ROC and NIST/USA.
 2. The test was performed in HwaYa Shielded Room 1.
 3. The VCCI Site Registration No. is C-2040.

4.2.3 Test Procedures

- a. The EUT was placed 0.4 meters from the conducting wall of the shielded room with EUT being connected to the power mains through a line impedance stabilization network (LISN). Other support units were connected to the power mains through another LISN. The two LISNs provide 50 ohm/ 50uH of coupling impedance for the measuring instrument.
- b. Both lines of the power mains connected to the EUT were checked for maximum conducted interference.
- c. The frequency range from 150 kHz to 30 MHz was searched. Emission levels under (Limit -20 dB) was not recorded.

Note: All modes of operation were investigated and the worst-case emissions are reported.

4.2.4 Deviation from Test Standard

No deviation.

4.2.5 Test Setup

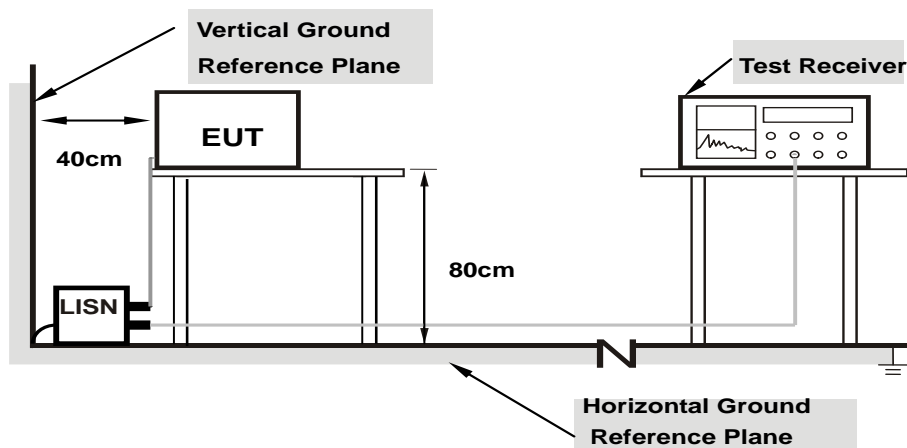

- Note:**
- 1.Support units were connected to second LISN.
 - 2.Both of LISNs (AMN) are 80 cm from EUT and at least 80 from other units and other metal planes

For the actual test configuration, please refer to the attached file (Test Setup Photo).

4.2.6 EUT Operating Conditions

- a. Placed the EUT on a testing table.
- b. Use the software to control the EUT under transmission condition continuously at specific channel frequency.

4.2.7 Test Results

| | | | |
|-----------------|----------------|--|--------------------------------------|
| Frequency Range | 150kHz ~ 30MHz | Detector Function & Resolution Bandwidth | Quasi-Peak (QP) / Average (AV), 9kHz |
| Input Power | 120Vac, 60Hz | Environmental Conditions | 25°C, 65%RH |
| Tested by | Getaz Yang | Test Date | 2017/7/6 |

| Phase Of Power : Line (L) | | | | | | | | | | |
|---------------------------|-----------------|------------------------|----------------------|-------|-----------------------|-------|--------------|-------|-------------|--------|
| No | Frequency (MHz) | Correction Factor (dB) | Reading Value (dBuV) | | Emission Level (dBuV) | | Limit (dBuV) | | Margin (dB) | |
| | | | Q.P. | AV. | Q.P. | AV. | Q.P. | AV. | Q.P. | AV. |
| 1 | 0.15400 | 10.35 | 36.33 | 20.83 | 46.68 | 31.18 | 65.78 | 55.78 | -19.10 | -24.60 |
| 2 | 0.16600 | 10.35 | 35.17 | 20.22 | 45.52 | 30.57 | 65.16 | 55.16 | -19.64 | -24.59 |
| 3 | 0.19000 | 10.36 | 31.39 | 18.38 | 41.75 | 28.74 | 64.04 | 54.04 | -22.29 | -25.30 |
| 4 | 1.09400 | 10.41 | 5.13 | 0.85 | 15.54 | 11.26 | 56.00 | 46.00 | -40.46 | -34.74 |
| 5 | 4.81400 | 10.61 | 10.38 | 5.82 | 20.99 | 16.43 | 56.00 | 46.00 | -35.01 | -29.57 |
| 6 | 15.01400 | 11.09 | 12.21 | 7.61 | 23.30 | 18.70 | 60.00 | 50.00 | -36.70 | -31.30 |

Remarks:

1. Q.P. and AV. are abbreviations of quasi-peak and average individually.
2. The emission levels of other frequencies were very low against the limit.
3. Margin value = Emission level – Limit value
4. Correction factor = Insertion loss + Cable loss
5. Emission Level = Correction Factor + Reading Value

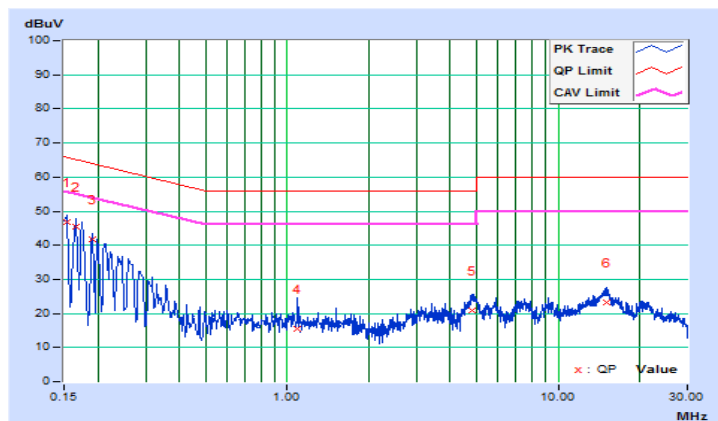

| | | | |
|-----------------|----------------|--|--------------------------------------|
| Frequency Range | 150kHz ~ 30MHz | Detector Function & Resolution Bandwidth | Quasi-Peak (QP) / Average (AV), 9kHz |
| Input Power | 120Vac, 60Hz | Environmental Conditions | 25°C, 65%RH |
| Tested by | Getaz Yang | Test Date | 2017/7/6 |

| Phase Of Power : Neutral (N) | | | | | | | | | | |
|------------------------------|-----------------|------------------------|----------------------|-------|-----------------------|-------|--------------|-------|-------------|--------|
| No | Frequency (MHz) | Correction Factor (dB) | Reading Value (dBuV) | | Emission Level (dBuV) | | Limit (dBuV) | | Margin (dB) | |
| | | | Q.P. | AV. | Q.P. | AV. | Q.P. | AV. | Q.P. | AV. |
| 1 | 0.17111 | 10.12 | 31.05 | 19.85 | 41.17 | 29.97 | 64.91 | 54.91 | -23.74 | -24.94 |
| 2 | 0.19418 | 10.14 | 27.14 | 16.45 | 37.28 | 26.59 | 63.86 | 53.86 | -26.58 | -27.27 |
| 3 | 0.24228 | 10.14 | 22.01 | 10.72 | 32.15 | 20.86 | 62.02 | 52.02 | -29.87 | -31.16 |
| 4 | 1.71400 | 10.21 | 9.35 | 5.34 | 19.56 | 15.55 | 56.00 | 46.00 | -36.44 | -30.45 |
| 5 | 3.41800 | 10.31 | 12.39 | 7.10 | 22.70 | 17.41 | 56.00 | 46.00 | -33.30 | -28.59 |
| 6 | 9.23000 | 10.52 | 8.88 | 4.23 | 19.40 | 14.75 | 60.00 | 50.00 | -40.60 | -35.25 |

Remarks:

1. Q.P. and AV. are abbreviations of quasi-peak and average individually.
2. The emission levels of other frequencies were very low against the limit.
3. Margin value = Emission level – Limit value
4. Correction factor = Insertion loss + Cable loss
5. Emission Level = Correction Factor + Reading Value

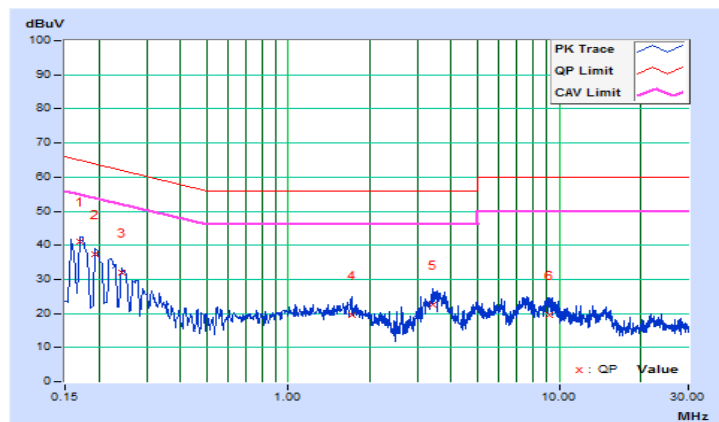

4.3 Transmit Power Measurement

4.3.1 Limits of Transmit Power Measurement

| Operation Band | EUT Category | Limit |
|----------------|-------------------------------------|---|
| U-NII-1 | Outdoor Access Point | 1 Watt (30 dBm) (Max. e.i.r.p \leq 125 mW (21 dBm) at any elevation angle above 30 degrees as measured from the horizon) |
| | Fixed point-to-point Access Point | 1 Watt (30 dBm) |
| | Indoor Access Point | 1 Watt (30 dBm) |
| | √ Mobile and Portable client device | 250 mW (24 dBm) |
| U-NII-2A | √ | 250 mW (24 dBm) or 11 dBm+10 log B* |
| U-NII-2C | √ | 250 mW (24 dBm) or 11 dBm+10 log B* |
| U-NII-3 | √ | 1 Watt (30 dBm) |

*B is the 26 dB emission bandwidth in megahertz

4.3.2 Test Setup

<Power Output Measurement>

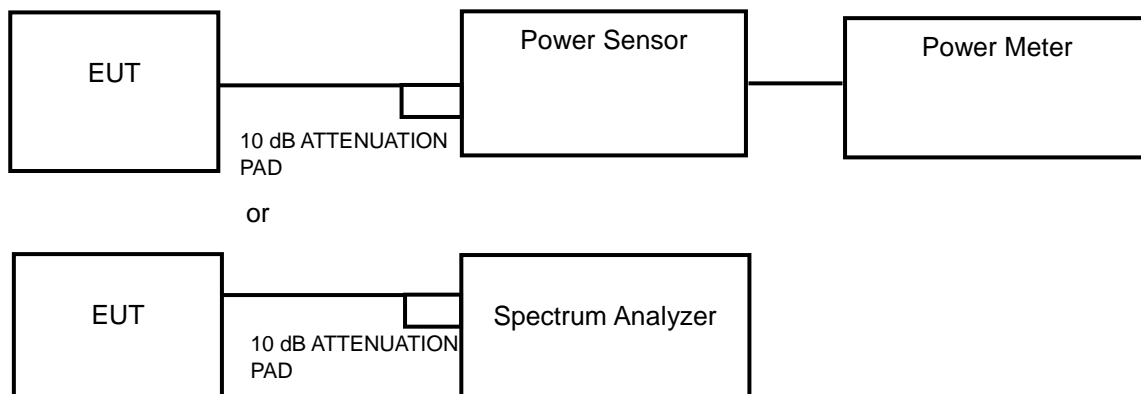

<26 dB Bandwidth>

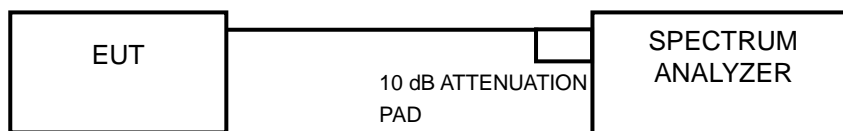

4.3.3 Test Instruments

Refer to section 4.1.2 to get information of above instrument.

4.3.4 Test Procedure

Average Power Measurement

<802.11a, 802.11n (HT20), 802.11n (HT40)>

Method PM is used to perform output power measurement, trigger and gating function of wide band power meter is enabled to measure max output power of TX on burst. Duty factor is not added to measured value.

<802.11ac (VHT80)>

Method SA-1 is used to perform output power measurement, trigger and gating function of spectrum analyzer is enabled to measure max output power of TX on burst. Duty factor is not added to measured value.

26 dB Bandwidth

- 1) Set RBW = approximately 1 % of the emission bandwidth.
- 2) Set the VBW > RBW.
- 3) Detector = Peak.
- 4) Trace mode = max hold.
- 5) Measure the maximum width of the emission that is 26 dB down from the peak of the emission. Compare this with the RBW setting of the analyzer. Readjust RBW and repeat measurement as needed until the RBW/EBW ratio is approximately 1 %.

4.3.5 Deviation from Test Standard

No deviation.

4.3.6 EUT Operating Conditions

The software provided by client to enable the EUT under transmission condition continuously at lowest, middle and highest channel frequencies individually.

4.3.7 Test Result

Power Output:

802.11a

| Channel | Frequency (MHz) | Maximum Conducted Power (mW) | Maximum Conducted Power (dBm) | Power Limit (dBm) | Pass / Fail |
|---------|-----------------|------------------------------|-------------------------------|-------------------|-------------|
| 36 | 5180 | 51.761 | 17.14 | 24 | Pass |
| 44 | 5220 | 52.723 | 17.22 | 24 | Pass |
| 48 | 5240 | 52.845 | 17.23 | 24 | Pass |
| 52 | 5260 | 54.200 | 17.34 | 24 | Pass |
| 60 | 5300 | 53.951 | 17.32 | 24 | Pass |
| 64 | 5320 | 53.580 | 17.29 | 24 | Pass |
| 100 | 5500 | 54.075 | 17.33 | 24 | Pass |
| 116 | 5580 | 53.333 | 17.27 | 24 | Pass |
| 140 | 5700 | 53.211 | 17.26 | 24 | Pass |
| 149 | 5745 | 53.951 | 17.32 | 30 | Pass |
| 157 | 5785 | 52.966 | 17.24 | 30 | Pass |
| 165 | 5825 | 53.088 | 17.25 | 30 | Pass |

Note:

For U-NII-2A, U-NII-2C Band:

1. $11 \text{ dBm} + 10\log(22.39) = 24.50 \text{ dBm} > 24 \text{ dBm}$.
2. $11 \text{ dBm} + 10\log(23.00) = 24.62 \text{ dBm} > 24 \text{ dBm}$.
3. $11 \text{ dBm} + 10\log(22.39) = 24.50 \text{ dBm} > 24 \text{ dBm}$.
4. $11 \text{ dBm} + 10\log(22.45) = 24.51 \text{ dBm} > 24 \text{ dBm}$.
5. $11 \text{ dBm} + 10\log(22.49) = 24.52 \text{ dBm} > 24 \text{ dBm}$.
6. $11 \text{ dBm} + 10\log(22.47) = 24.52 \text{ dBm} > 24 \text{ dBm}$.

802.11n (HT20)

| Channel | Frequency (MHz) | Maximum Conducted Power (mW) | Maximum Conducted Power (dBm) | Power Limit (dBm) | Pass / Fail |
|---------|-----------------|------------------------------|-------------------------------|-------------------|-------------|
| 36 | 5180 | 52.240 | 17.18 | 24 | Pass |
| 44 | 5220 | 52.723 | 17.22 | 24 | Pass |
| 48 | 5240 | 53.211 | 17.26 | 24 | Pass |
| 52 | 5260 | 54.702 | 17.38 | 24 | Pass |
| 60 | 5300 | 54.075 | 17.33 | 24 | Pass |
| 64 | 5320 | 53.333 | 17.27 | 24 | Pass |
| 100 | 5500 | 54.075 | 17.33 | 24 | Pass |
| 116 | 5580 | 53.456 | 17.28 | 24 | Pass |
| 140 | 5700 | 52.602 | 17.21 | 24 | Pass |
| 149 | 5745 | 54.325 | 17.35 | 30 | Pass |
| 157 | 5785 | 53.333 | 17.27 | 30 | Pass |
| 165 | 5825 | 52.602 | 17.21 | 30 | Pass |

Note:

For U-NII-2A, U-NII-2C Band:

1. $11 \text{ dBm} + 10\log(24.37) = 24.87 \text{ dBm} > 24 \text{ dBm}$.
2. $11 \text{ dBm} + 10\log(24.00) = 24.80 \text{ dBm} > 24 \text{ dBm}$.
3. $11 \text{ dBm} + 10\log(24.65) = 24.92 \text{ dBm} > 24 \text{ dBm}$.
4. $11 \text{ dBm} + 10\log(24.49) = 24.89 \text{ dBm} > 24 \text{ dBm}$.
5. $11 \text{ dBm} + 10\log(23.58) = 24.73 \text{ dBm} > 24 \text{ dBm}$.
6. $11 \text{ dBm} + 10\log(24.91) = 24.96 \text{ dBm} > 24 \text{ dBm}$.

802.11n (HT40)

| Channel | Frequency (MHz) | Maximum Conducted Power (mW) | Maximum Conducted Power (dBm) | Power Limit (dBm) | Pass / Fail |
|---------|-----------------|------------------------------|-------------------------------|-------------------|-------------|
| 38 | 5190 | 52.240 | 17.18 | 24 | Pass |
| 46 | 5230 | 53.211 | 17.26 | 24 | Pass |
| 54 | 5270 | 53.456 | 17.28 | 24 | Pass |
| 62 | 5310 | 53.951 | 17.32 | 24 | Pass |
| 102 | 5510 | 54.450 | 17.36 | 24 | Pass |
| 110 | 5550 | 53.827 | 17.31 | 24 | Pass |
| 134 | 5670 | 53.333 | 17.27 | 24 | Pass |
| 151 | 5755 | 51.642 | 17.13 | 30 | Pass |
| 159 | 5795 | 53.211 | 17.26 | 30 | Pass |

Note:

For U-NII-2A, U-NII-2C Band:

1. $11 \text{ dBm} + 10\log(42.23) = 27.26 \text{ dBm} > 24 \text{ dBm}$.
2. $11 \text{ dBm} + 10\log(42.17) = 27.25 \text{ dBm} > 24 \text{ dBm}$.
3. $11 \text{ dBm} + 10\log(42.21) = 27.25 \text{ dBm} > 24 \text{ dBm}$.
4. $11 \text{ dBm} + 10\log(42.16) = 27.25 \text{ dBm} > 24 \text{ dBm}$.
5. $11 \text{ dBm} + 10\log(42.07) = 27.24 \text{ dBm} > 24 \text{ dBm}$.

802.11ac (VHT80)

| Channel | Frequency (MHz) | Maximum Conducted Power (mW) | Maximum Conducted Power (dBm) | Power Limit (dBm) | Pass / Fail |
|---------|-----------------|------------------------------|-------------------------------|-------------------|-------------|
| 42 | 5210 | 47.863 | 16.80 | 24 | Pass |
| 58 | 5290 | 43.053 | 16.34 | 24 | Pass |
| 106 | 5530 | 43.551 | 16.39 | 24 | Pass |
| 122 | 5610 | 43.152 | 16.35 | 24 | Pass |
| 155 | 5775 | 41.879 | 16.22 | 30 | Pass |

Note:

For U-NII-2A, U-NII-2C Band:

1. $11 \text{ dBm} + 10\log(84.63) = 30.28 \text{ dBm} > 24 \text{ dBm}$.
2. $11 \text{ dBm} + 10\log(84.80) = 30.28 \text{ dBm} > 24 \text{ dBm}$.
3. $11 \text{ dBm} + 10\log(84.65) = 30.28 \text{ dBm} > 24 \text{ dBm}$.

26 dB Bandwidth:
802.11a

| Channel | Frequency (MHz) | 26 dBc Bandwidth (MHz) |
|---------|-----------------|------------------------|
| 36 | 5180 | 22.97 |
| 44 | 5220 | 22.99 |
| 48 | 5240 | 23.08 |
| 52 | 5260 | 22.39 |
| 60 | 5300 | 23.00 |
| 64 | 5320 | 22.39 |
| 100 | 5500 | 22.45 |
| 116 | 5580 | 22.49 |
| 140 | 5700 | 22.47 |

802.11n (HT20)

| Channel | Frequency (MHz) | 26 dBc Bandwidth (MHz) |
|---------|-----------------|------------------------|
| 36 | 5180 | 23.42 |
| 44 | 5220 | 24.30 |
| 48 | 5240 | 24.01 |
| 52 | 5260 | 24.37 |
| 60 | 5300 | 24.00 |
| 64 | 5320 | 24.65 |
| 100 | 5500 | 24.49 |
| 116 | 5580 | 23.58 |
| 140 | 5700 | 24.91 |

802.11n (HT40)

| Channel | Frequency (MHz) | 26 dBc Bandwidth (MHz) |
|---------|-----------------|------------------------|
| 38 | 5190 | 42.11 |
| 46 | 5230 | 42.12 |
| 54 | 5270 | 42.23 |
| 62 | 5310 | 42.17 |
| 102 | 5510 | 42.21 |
| 110 | 5550 | 42.16 |
| 134 | 5670 | 42.07 |

802.11ac (VHT80)

| Channel | Frequency (MHz) | 26 dBc Bandwidth (MHz) |
|---------|-----------------|------------------------|
| 42 | 5210 | 84.68 |
| 58 | 5290 | 84.63 |
| 106 | 5530 | 84.80 |
| 122 | 5610 | 84.65 |

Spectrum Plot of Worst Value

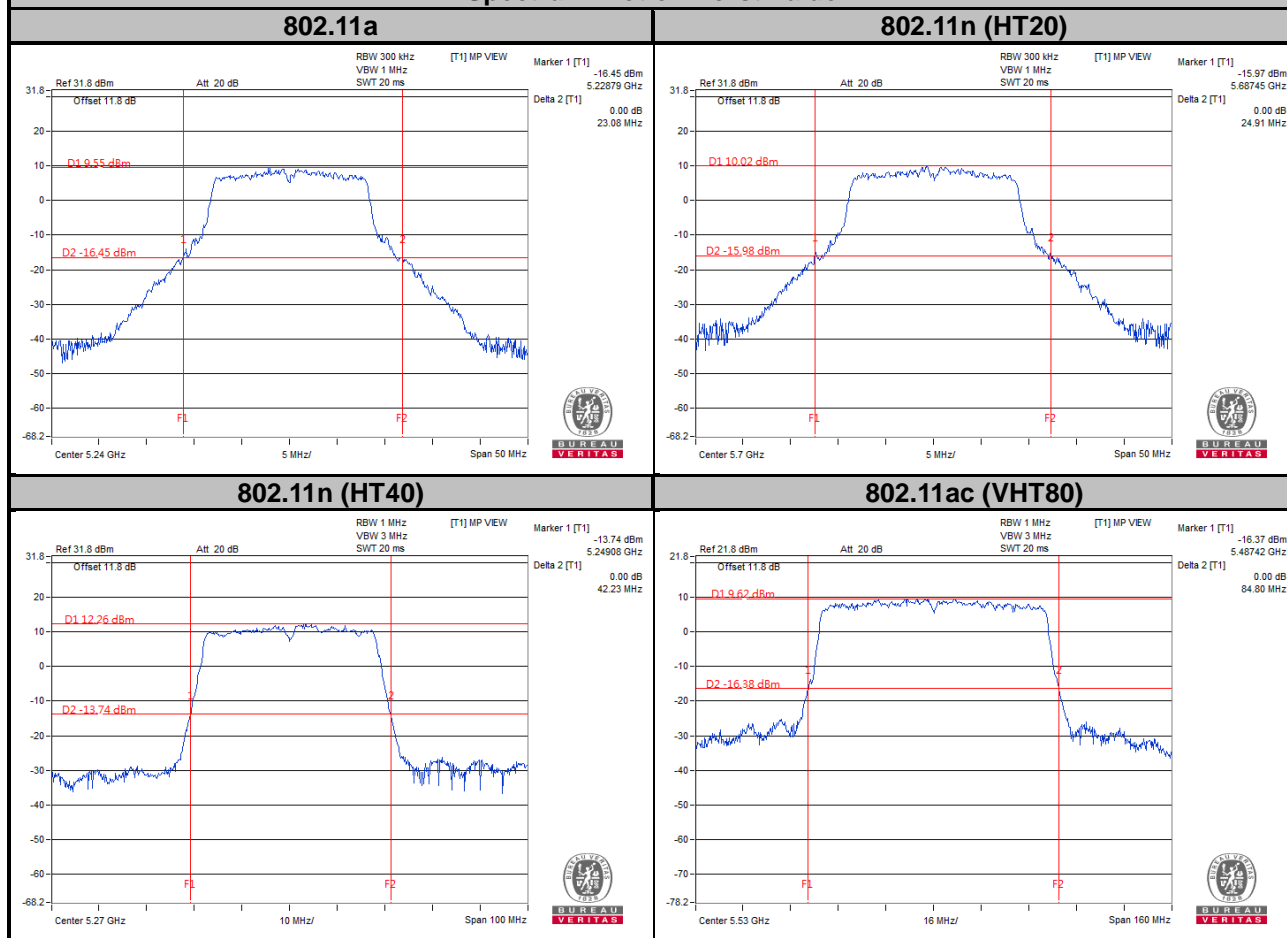

4.4 Peak Power Spectral Density Measurement

4.4.1 Limits of Peak Power Spectral Density Measurement

| Operation Band | EUT Category | | Limit |
|----------------|--------------|-----------------------------------|----------------|
| U-NII-1 | | Outdoor Access Point | 17 dBm/MHz |
| | | Fixed point-to-point Access Point | |
| | | Indoor Access Point | |
| | √ | Mobile and Portable client device | 11 dBm/MHz |
| U-NII-2A | | √ | 11 dBm/MHz |
| U-NII-2C | | √ | 11 dBm/MHz |
| U-NII-3 | | √ | 30 dBm/500 kHz |

4.4.2 Test Setup

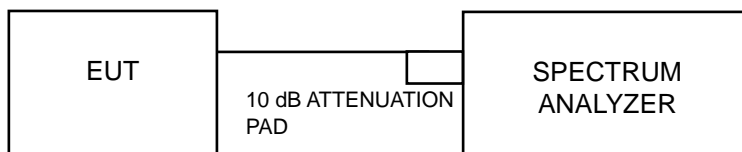

4.4.3 Test Instruments

Refer to section 4.1.3 to get information of above instrument.

4.4.4 Test Procedures

For U-NII-1, U-NII-2A, U-NII-2C band:

Using method SA-2

1. Set span to encompass the entire emission bandwidth (EBW) of the signal.
2. Set RBW = 1 MHz, Set VBW \geq 3 RBW, Detector = RMS
3. Sweep time = auto, trigger set to "free run".
4. Trace average at least 100 traces in power averaging mode.
5. Record the max value and add 10 log (1/duty cycle)

※For U-NII-3:

1. Set span to encompass the entire emission bandwidth (EBW) of the signal.
2. Set RBW = 500 kHz, Set VBW \geq 3 RBW, Detector = RMS
3. Use the peak marker function to determine the maximum power level in any 500 kHz band segment within the fundamental EBW.
4. Sweep time = auto, trigger set to "free run".
5. Trace average at least 100 traces in power averaging mode.
6. Record the max value and add 10 log (1/duty cycle)

4.4.5 Deviation from Test Standard

No deviation.

4.4.6 EUT Operating Conditions

The software provided by client to enable the EUT under transmission condition continuously at lowest, middle and highest channel frequencies individually.

4.4.7 Test Results

802.11a

| Channel | Frequency (MHz) | PSD w/o Duty Factor (dBm/MHz) | Duty Factor (dB) | PSD with Duty Factor (dBm/MHz) | Maximum Limit (dBm/MHz) | Pass / Fail |
|---------|-----------------|-------------------------------|------------------|--------------------------------|-------------------------|-------------|
| 36 | 5180 | 6.43 | 0.26 | 6.69 | 11 | Pass |
| 44 | 5220 | 6.66 | 0.26 | 6.92 | 11 | Pass |
| 48 | 5240 | 6.70 | 0.26 | 6.96 | 11 | Pass |
| 52 | 5260 | 6.56 | 0.26 | 6.82 | 11 | Pass |
| 60 | 5300 | 6.42 | 0.26 | 6.68 | 11 | Pass |
| 64 | 5320 | 6.58 | 0.26 | 6.84 | 11 | Pass |
| 100 | 5500 | 6.82 | 0.26 | 7.08 | 11 | Pass |
| 116 | 5580 | 6.77 | 0.26 | 7.03 | 11 | Pass |
| 140 | 5700 | 6.36 | 0.26 | 6.62 | 11 | Pass |

Note: Refer to section 3.3 for duty cycle spectrum plot.

802.11n (HT20)

| Channel | Frequency (MHz) | PSD w/o Duty Factor (dBm/MHz) | Duty Factor (dB) | PSD with Duty Factor (dBm/MHz) | Maximum Limit (dBm/MHz) | Pass / Fail |
|---------|-----------------|-------------------------------|------------------|--------------------------------|-------------------------|-------------|
| 36 | 5180 | 6.31 | 0.28 | 6.59 | 11 | Pass |
| 44 | 5220 | 6.55 | 0.28 | 6.83 | 11 | Pass |
| 48 | 5240 | 6.65 | 0.28 | 6.93 | 11 | Pass |
| 52 | 5260 | 6.47 | 0.28 | 6.75 | 11 | Pass |
| 60 | 5300 | 6.25 | 0.28 | 6.53 | 11 | Pass |
| 64 | 5320 | 6.45 | 0.28 | 6.73 | 11 | Pass |
| 100 | 5500 | 6.58 | 0.28 | 6.86 | 11 | Pass |
| 116 | 5580 | 6.75 | 0.28 | 7.03 | 11 | Pass |
| 140 | 5700 | 6.54 | 0.28 | 6.82 | 11 | Pass |

Note: Refer to section 3.3 for duty cycle spectrum plot.

802.11n (HT40)

| Channel | Frequency (MHz) | PSD w/o Duty Factor (dBm/MHz) | Duty Factor (dB) | PSD with Duty Factor (dBm/MHz) | Maximum Limit (dBm/MHz) | Pass / Fail |
|---------|-----------------|-------------------------------|------------------|--------------------------------|-------------------------|-------------|
| 38 | 5190 | 3.75 | 0.60 | 4.35 | 11 | Pass |
| 46 | 5230 | 4.05 | 0.60 | 4.65 | 11 | Pass |
| 54 | 5270 | 4.16 | 0.60 | 4.76 | 11 | Pass |
| 62 | 5310 | 4.05 | 0.60 | 4.65 | 11 | Pass |
| 102 | 5510 | 4.17 | 0.60 | 4.77 | 11 | Pass |
| 110 | 5550 | 4.10 | 0.60 | 4.70 | 11 | Pass |
| 134 | 5670 | 4.03 | 0.60 | 4.63 | 11 | Pass |

Note: Refer to section 3.3 for duty cycle spectrum plot.

802.11ac (VHT80)

| Channel | Frequency (MHz) | PSD w/o Duty Factor (dBm/MHz) | Duty Factor (dB) | PSD with Duty Factor (dBm/MHz) | Maximum Limit (dBm/MHz) | Pass / Fail |
|---------|-----------------|-------------------------------|------------------|--------------------------------|-------------------------|-------------|
| 42 | 5210 | -0.61 | 1.08 | 0.47 | 11 | Pass |
| 58 | 5290 | -0.69 | 1.08 | 0.39 | 11 | Pass |
| 106 | 5530 | -0.56 | 1.08 | 0.52 | 11 | Pass |
| 122 | 5610 | -0.66 | 1.08 | 0.42 | 11 | Pass |

Note: Refer to section 3.3 for duty cycle spectrum plot.

Spectrum Plot of Worst Value

802.11a

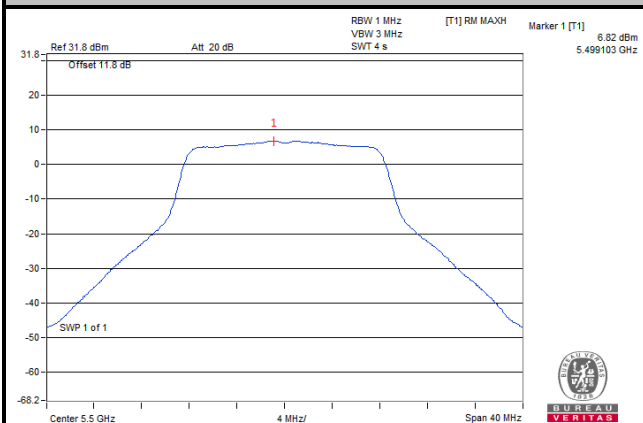

802.11n (HT20)

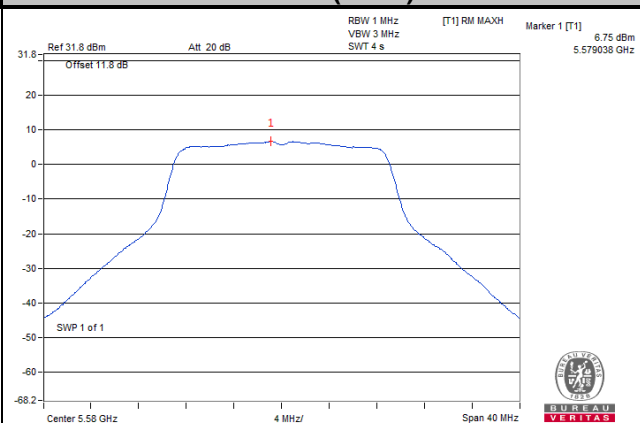

802.11n (HT40)

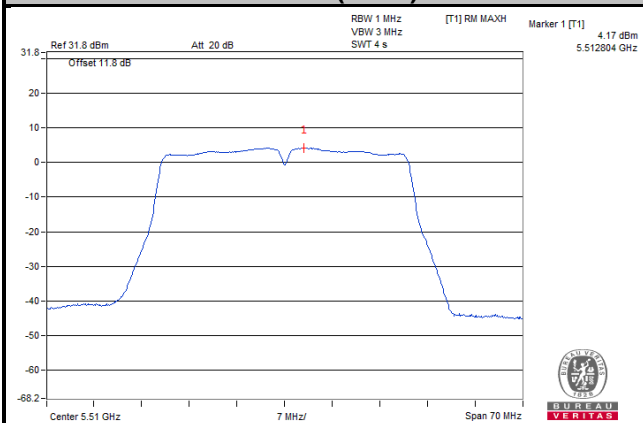

802.11ac (VHT80)

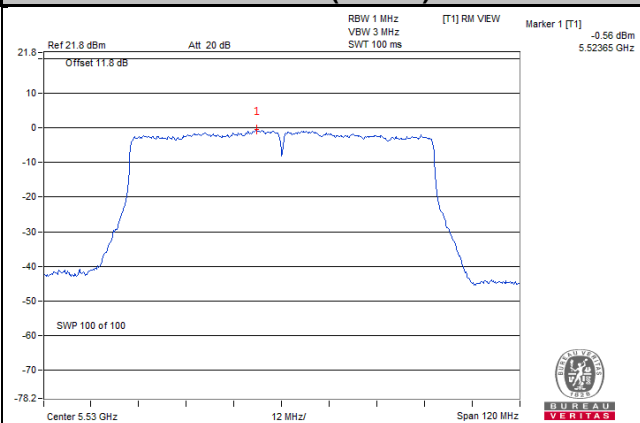

For U-NII-3 Band

802.11a

| Channel | Frequency (MHz) | PSD w/o Duty Factor (dBm/500 kHz) | Duty Factor (dB) | PSD with Duty Factor (dBm/500 kHz) | Limit (dBm/500 kHz) | Pass / Fail |
|---------|-----------------|-----------------------------------|------------------|------------------------------------|---------------------|-------------|
| 149 | 5745 | 3.40 | 0.26 | 3.66 | 30 | Pass |
| 157 | 5785 | 3.24 | 0.26 | 3.50 | 30 | Pass |
| 165 | 5825 | 3.20 | 0.26 | 3.46 | 30 | Pass |

Note: Refer to section 3.3 for duty cycle spectrum plot.

802.11n (HT20)

| Channel | Frequency (MHz) | PSD w/o Duty Factor (dBm/500 kHz) | Duty Factor (dB) | PSD with Duty Factor (dBm/500 kHz) | Limit (dBm/500 kHz) | Pass / Fail |
|---------|-----------------|-----------------------------------|------------------|------------------------------------|---------------------|-------------|
| 149 | 5745 | 3.18 | 0.28 | 3.46 | 30 | Pass |
| 157 | 5785 | 3.06 | 0.28 | 3.34 | 30 | Pass |
| 165 | 5825 | 2.95 | 0.28 | 3.23 | 30 | Pass |

Note: Refer to section 3.3 for duty cycle spectrum plot.

802.11n (HT40)

| Channel | Frequency (MHz) | PSD w/o Duty Factor (dBm/500 kHz) | Duty Factor (dB) | PSD with Duty Factor (dBm/500 kHz) | Limit (dBm/500 kHz) | Pass / Fail |
|---------|-----------------|-----------------------------------|------------------|------------------------------------|---------------------|-------------|
| 151 | 5755 | -0.26 | 0.60 | 0.34 | 30 | Pass |
| 159 | 5795 | 0.14 | 0.60 | 0.74 | 30 | Pass |

Note: Refer to section 3.3 for duty cycle spectrum plot.

802.11ac (VHT80)

| Channel | Frequency (MHz) | PSD w/o Duty Factor (dBm/500 kHz) | Duty Factor (dB) | PSD with Duty Factor (dBm/500 kHz) | Limit (dBm/500 kHz) | Pass / Fail |
|---------|-----------------|-----------------------------------|------------------|------------------------------------|---------------------|-------------|
| 155 | 5775 | -3.03 | 1.08 | -1.95 | 30 | Pass |

Note: Refer to section 3.3 for duty cycle spectrum plot.

Spectrum Plot of Worst Value

802.11a

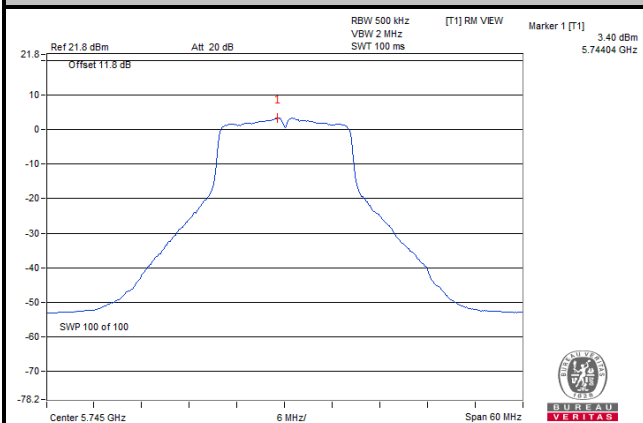

802.11n (HT20)

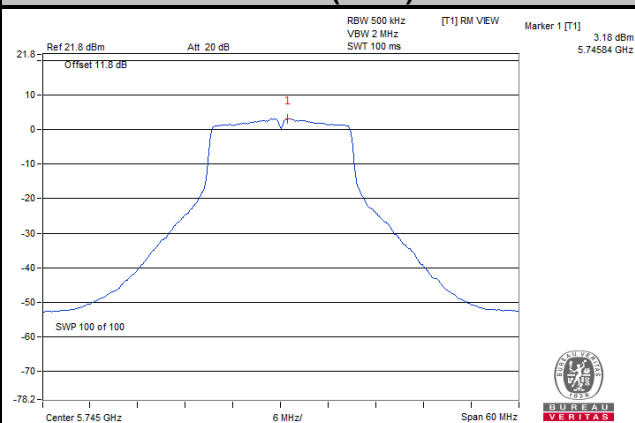

802.11n (HT40)

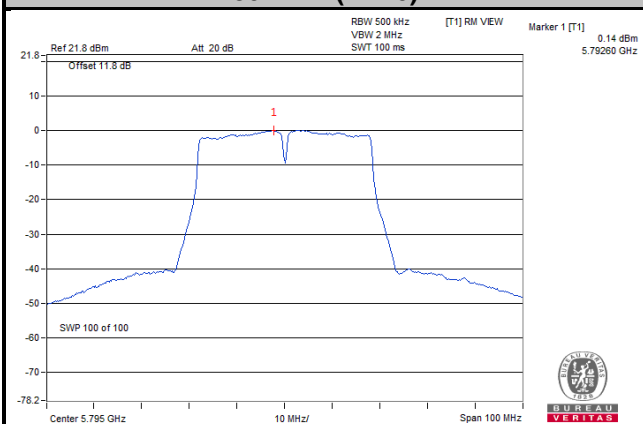

802.11ac (VHT80)

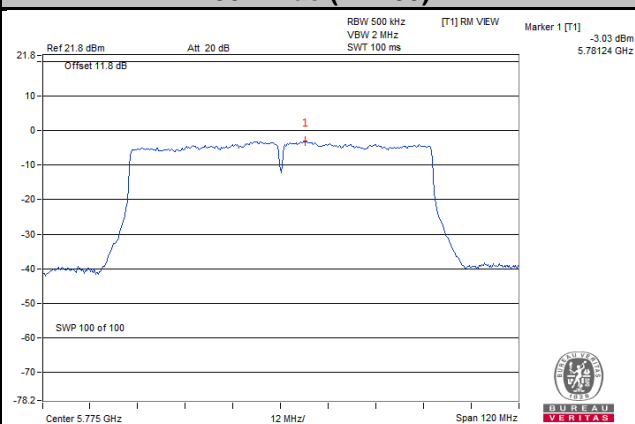

4.5 Frequency Stability

4.5.1 Limit of Frequency Stability Measurement

The frequency of the carrier signal shall be maintained within band of operation.

4.5.2 Test Setup

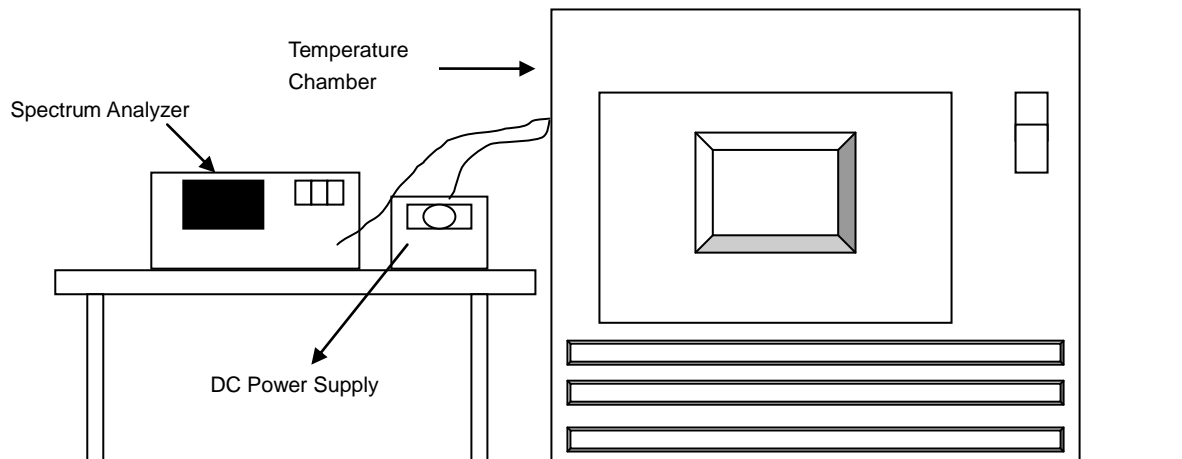

4.5.3 Test Instruments

Refer to section 4.1.3 to get information of above instrument.

4.5.4 Test Procedure

- To ensure emission at the band edge is maintained within the authorized band, those values shall be measured by radiation emissions at upper and lower frequency points, and finally compensated by frequency deviation as procedures below.
- The EUT was operated at the maximum output power, and connected to the spectrum analyzer, which is set to maximum hold function and peak detector. The peak value of the power envelope was measured and noted. The upper and lower frequency points were respectively measured relatively 10 dB lower than the measured peak value.
- The frequency deviation was calculated by adding the upper frequency point and the lower frequency point divided by two. Those detailed values of frequency deviation are provided in table below.

4.5.5 Deviation from Test Standard

No deviation.

4.5.6 EUT Operating Condition

Set the EUT transmit at un-modulation mode to test frequency stability.

4.5.7 Test Results

| Frequency Stability Versus Temp. | | | | | | | | | |
|----------------------------------|--------------------|--------------------------|-----------------------|--------------------------|-----------------------|--------------------------|-----------------------|--------------------------|-----------------------|
| Operating Frequency: 5180 MHz | | | | | | | | | |
| Temp. () | Power Supply (Vdc) | 0 Minute | | 2 Minute | | 5 Minute | | 10 Minute | |
| | | Measured Frequency (MHz) | Frequency Drift (ppm) | Measured Frequency (MHz) | Frequency Drift (ppm) | Measured Frequency (MHz) | Frequency Drift (ppm) | Measured Frequency (MHz) | Frequency Drift (ppm) |
| 55 | 3.85 | 5179.9828 | -0.00033 | 5179.9821 | -0.00035 | 5179.9843 | -0.00030 | 5179.9859 | -0.00027 |
| 50 | 3.85 | 5179.9849 | -0.00029 | 5179.9868 | -0.00025 | 5179.985 | -0.00029 | 5179.9889 | -0.00021 |
| 40 | 3.85 | 5180.003 | 0.00006 | 5180.0027 | 0.00005 | 5180.0036 | 0.00007 | 5180.0024 | 0.00005 |
| 30 | 3.85 | 5180.0231 | 0.00045 | 5180.0228 | 0.00044 | 5180.0257 | 0.00050 | 5180.0237 | 0.00046 |
| 20 | 3.85 | 5180.0088 | 0.00017 | 5180.008 | 0.00015 | 5180.0084 | 0.00016 | 5180.007 | 0.00014 |
| 10 | 3.85 | 5180.0037 | 0.00007 | 5180.0055 | 0.00011 | 5180.0057 | 0.00011 | 5180.0029 | 0.00006 |
| 0 | 3.85 | 5180.003 | 0.00006 | 5180.0031 | 0.00006 | 5179.9995 | -0.00001 | 5180.0004 | 0.00001 |
| -10 | 3.85 | 5179.9829 | -0.00033 | 5179.9803 | -0.00038 | 5179.9833 | -0.00032 | 5179.9807 | -0.00037 |
| -20 | 3.85 | 5180.0154 | 0.00030 | 5180.0115 | 0.00022 | 5180.0156 | 0.00030 | 5180.0138 | 0.00027 |
| -30 | 3.85 | 5179.993 | -0.00014 | 5179.9963 | -0.00007 | 5179.9969 | -0.00006 | 5179.9945 | -0.00011 |

| Frequency Stability Versus Temp. | | | | | | | | | |
|----------------------------------|--------------------|--------------------------|-----------------------|--------------------------|-----------------------|--------------------------|-----------------------|--------------------------|-----------------------|
| Operating Frequency: 5180 MHz | | | | | | | | | |
| Temp. () | Power Supply (Vdc) | 0 Minute | | 2 Minute | | 5 Minute | | 10 Minute | |
| | | Measured Frequency (MHz) | Frequency Drift (ppm) | Measured Frequency (MHz) | Frequency Drift (ppm) | Measured Frequency (MHz) | Frequency Drift (ppm) | Measured Frequency (MHz) | Frequency Drift (ppm) |
| 20 | 4.4275 | 5180.0084 | 0.00016 | 5180.0089 | 0.00017 | 5180.0084 | 0.00016 | 5180.008 | 0.00015 |
| | 3.85 | 5180.0088 | 0.00017 | 5180.008 | 0.00015 | 5180.0084 | 0.00016 | 5180.007 | 0.00014 |
| | 3.2725 | 5180.0094 | 0.00018 | 5180.0082 | 0.00016 | 5180.0084 | 0.00016 | 5180.0075 | 0.00014 |

4.6 6 dB Bandwidth Measurement

4.6.1 Limits of 6 dB Bandwidth Measurement

The minimum of 6 dB Bandwidth Measurement is 0.5 MHz.

4.6.2 Test Setup

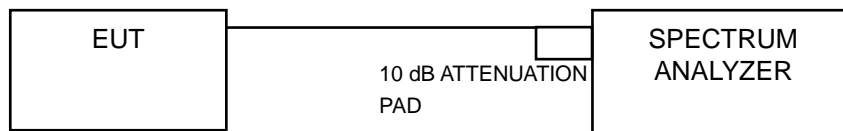

4.6.3 Test Instruments

Refer to section 4.1.3 to get information of above instrument.

4.6.4 Test Procedure

MEASUREMENT PROCEDURE REF

- Set resolution bandwidth (RBW) = 100 kHz
- Set the video bandwidth (VBW) $\geq 3 \times$ RBW, Detector = Peak.
- Trace mode = max hold.
- Sweep = auto couple.
- Measure the maximum width of the emission that is constrained by the frequencies associated with the two amplitude points (upper and lower) that are attenuated by 6 dB relative to the maximum level measured in the fundamental emission

4.6.5 Deviation from Test Standard

No deviation.

4.6.6 EUT Operating Condition

The software provided by client to enable the EUT under transmission condition continuously at lowest, middle and highest channel frequencies individually.

4.6.7 Test Results

802.11a

| Channel | Frequency (MHz) | 6 dB Bandwidth (MHz) | Minimum Limit (MHz) | Pass / Fail |
|---------|-----------------|----------------------|---------------------|-------------|
| 149 | 5745 | 15.56 | 0.5 | Pass |
| 157 | 5785 | 15.56 | 0.5 | Pass |
| 165 | 5825 | 15.15 | 0.5 | Pass |

802.11n (HT20)

| Channel | Frequency (MHz) | 6 dB Bandwidth (MHz) | Minimum Limit (MHz) | Pass / Fail |
|---------|-----------------|----------------------|---------------------|-------------|
| 149 | 5745 | 16.00 | 0.5 | Pass |
| 157 | 5785 | 15.17 | 0.5 | Pass |
| 165 | 5825 | 15.11 | 0.5 | Pass |

802.11n (HT40)

| Channel | Frequency (MHz) | 6 dB Bandwidth (MHz) | Minimum Limit (MHz) | Pass / Fail |
|---------|-----------------|----------------------|---------------------|-------------|
| 151 | 5755 | 35.37 | 0.5 | Pass |
| 159 | 5795 | 35.27 | 0.5 | Pass |

802.11ac (VHT80)

| Channel | Frequency (MHz) | 6 dB Bandwidth (MHz) | Minimum Limit (MHz) | Pass / Fail |
|---------|-----------------|----------------------|---------------------|-------------|
| 155 | 5775 | 75.54 | 0.5 | Pass |

Spectrum Plot of Worst Value

802.11a

802.11n (HT20)

802.11n (HT40)

802.11ac (VHT80)

5 Pictures of Test Arrangements

Please refer to the attached file (Test Setup Photo).

Annex A- Radiated Out of Band Emisison (OOBE) Measurement (For U-NII-3 band)

802.11a

| Ch 149 | |
|------------|----------|
| Horizontal | Vertical |
| | |
| Ch 157 | |
| Horizontal | Vertical |
| | |
| Ch 165 | |
| Horizontal | Vertical |
| | |

802.11n (HT20)

Ch 149

Horizontal

Vertical

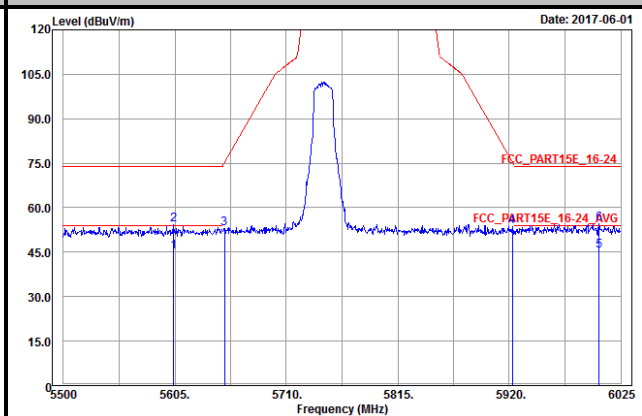

Ch 157

Horizontal

Vertical

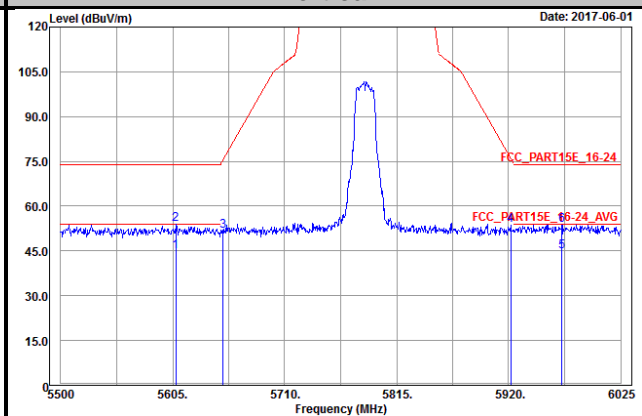
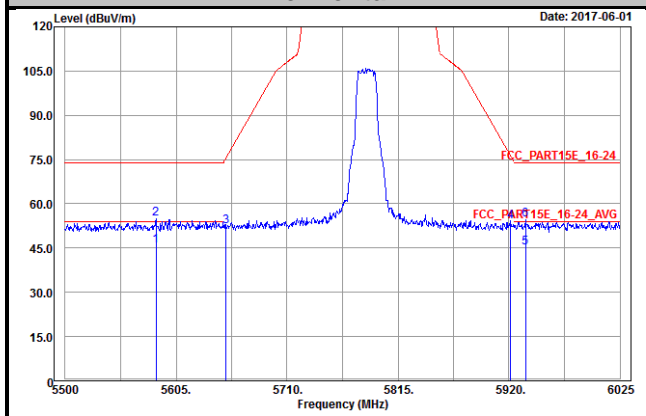

Ch 165

Horizontal

Vertical

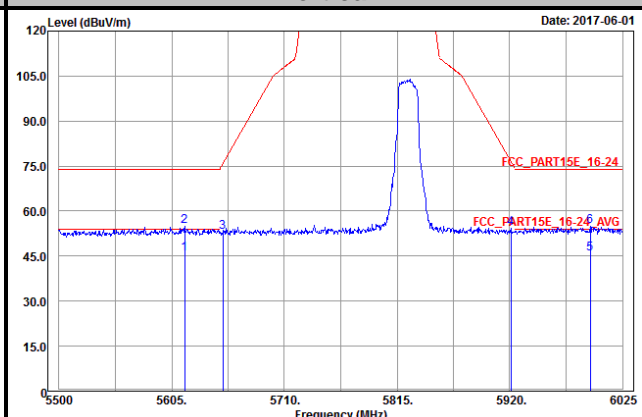
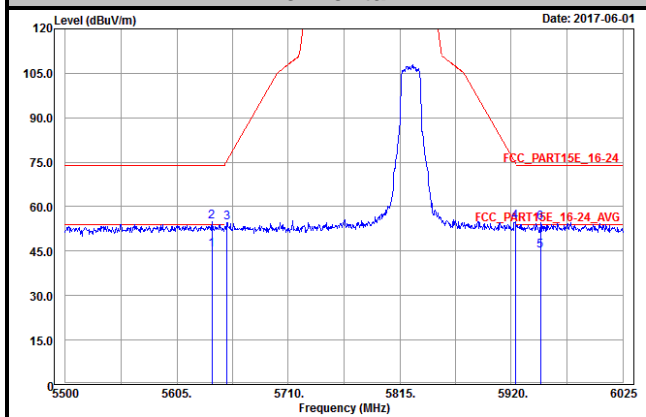

802.11n (HT40)

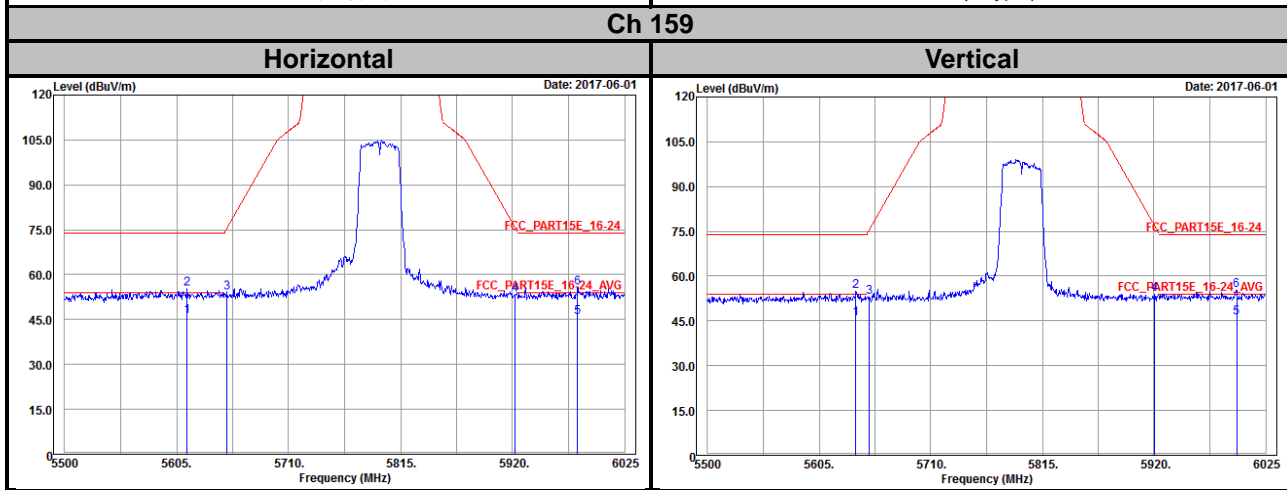
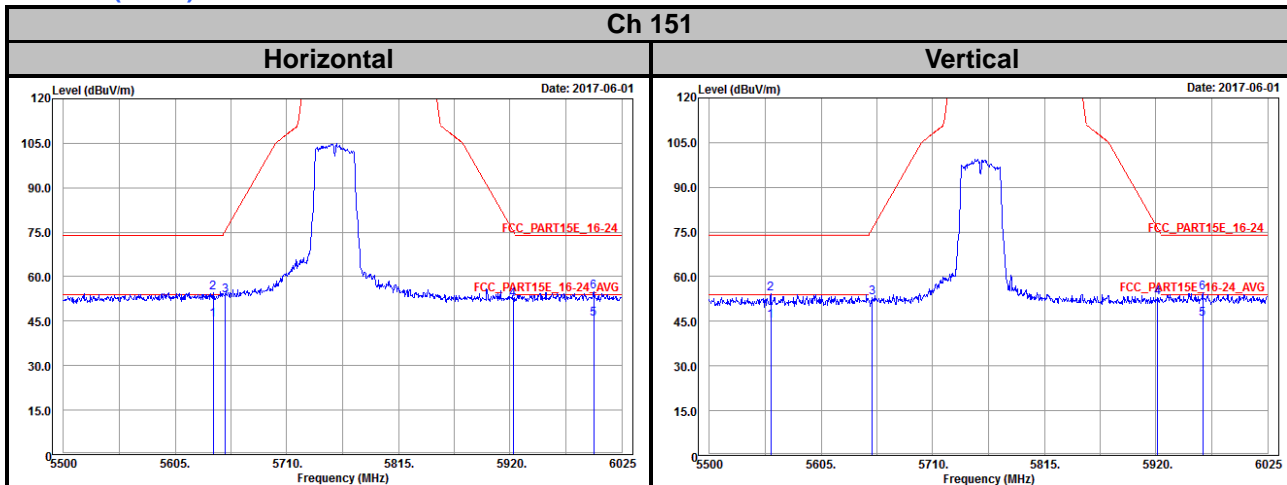

802.11ac (VHT80)

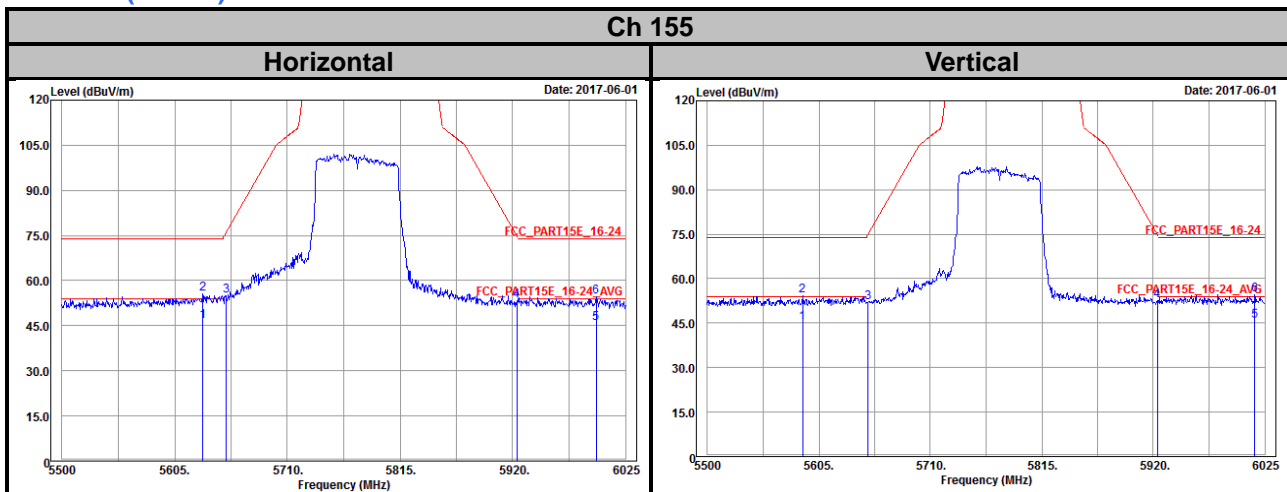

Appendix – Information on the Testing Laboratories

We, Bureau Veritas Consumer Products Services (H.K.) Ltd., Taoyuan Branch, were founded in 1988 to provide our best service in EMC, Radio, Telecom and Safety consultation. Our laboratories are FCC recognized accredited test firms and accredited and approved according to ISO/IEC 17025.

If you have any comments, please feel free to contact us at the following:

Linko EMC/RF Lab

Tel: 886-2-26052180

Fax: 886-2-26051924

Hsin Chu EMC/RF/Telecom Lab

Tel: 886-3-6668565

Fax: 886-3-6668323

Hwa Ya EMC/RF/Safety

Tel: 886-3-3183232

Fax: 886-3-3270892

Email: service.adt@tw.bureauveritas.com

Web Site: www.bureauveritas-adt.com

The address and road map of all our labs can be found in our web site also.

--- END ---