



FCC RF Test Report

APPLICANT : ASUSTeK COMPUTER INC.
EQUIPMENT : ASUS Phone(Mobile phone)
BRAND NAME : ASUS
MODEL NAME : ASUS_Z01GS
FCC ID : MSQZ01GS
STANDARD : FCC 47 CFR Part 2, 22(H), 24(E), 27(L)
CLASSIFICATION : PCS Licensed Transmitter Held to Ear (PCE)

The product was received on Apr. 08, 2017 and testing was completed on Sep. 18, 2017. We, SPORTON INTERNATIONAL INC., would like to declare that the tested sample has been evaluated in accordance with the test procedures given in ANSI / TIA / EIA-603-E-2016 and has been in compliance with the applicable technical standards.

The test results in this report apply exclusively to the tested model / sample. Without written approval of SPORTON INTERNATIONAL INC., the test report shall not be reproduced except in full.

Reviewed by: Joseph Lin / Supervisor

Approved by: Jones Tsai / Manager



SPORTON INTERNATIONAL INC.

No. 52, Hwa Ya 1st Rd., Hwa Ya Technology Park, Kwei-Shan District, Tao Yuan City, Taiwan, R.O.C.

SPORTON INTERNATIONAL INC.

TEL : 886-3-327-3456

FAX : 886-3-328-4978

FCC ID : MSQZ01GS

Page Number : 1 of 22

Report Issued Date : Oct. 13, 2017

Report Version : Rev. 02

Report Template No.: BU5-FG22/24/27 Version 2.0



TABLE OF CONTENTS

REVISION HISTORY..... 3

SUMMARY OF TEST RESULT 4

1 GENERAL DESCRIPTION 6

 1.1 Applicant..... 6

 1.2 Manufacturer 6

 1.3 Product Feature of Equipment Under Test 6

 1.4 Modification of EUT 7

 1.5 Testing Location 8

 1.6 Applicable Standards 8

2 TEST CONFIGURATION OF EQUIPMENT UNDER TEST 9

 2.1 Test Mode..... 9

 2.2 Connection Diagram of Test System 10

 2.3 Support Unit used in test configuration 10

 2.4 Measurement Results Explanation Example 10

 2.5 Frequency List of Low/Middle/High Channels..... 11

3 CONDUCTED TEST RESULT..... 12

 3.1 Measuring Instruments..... 12

 3.2 Test Setup 12

 3.3 Test Result of Conducted Test..... 12

 3.4 Conducted Output Power and ERP/EIRP 13

 3.5 Peak-to-Average Ratio 14

 3.6 99% Occupied Bandwidth and 26dB Bandwidth Measurement..... 15

 3.7 Conducted Band Edge 16

 3.8 Conducted Spurious Emission 17

 3.9 Frequency Stability..... 18

4 RADIATED TEST ITEMS 19

 4.1 Measuring Instruments..... 19

 4.2 Test Setup 19

 4.3 Test Result of Radiated Test..... 19

 4.4 Field Strength of Spurious Radiation Measurement 20

5 LIST OF MEASURING EQUIPMENT 21

6 UNCERTAINTY OF EVALUATION 22

APPENDIX A. TEST RESULTS OF CONDUCTED TEST

APPENDIX B. TEST RESULTS OF RADIATED TEST

APPENDIX C. TEST SETUP PHOTOGRAPHS



REVISION HISTORY

REPORT NO.	VERSION	DESCRIPTION	ISSUED DATE
FG740843A	Rev. 01	Initial issue of report	Oct. 05, 2017
FG740843A	Rev. 02	Revising ANSI / TIA / EIA-603-E-2016 information.	Oct. 13, 2017



SUMMARY OF TEST RESULT

Report Section	FCC Rule	Description	Limit	Result	Remark
3.4	§2.1046	Conducted Output Power	Reporting Only	PASS	-
	§22.913(a)(2)	Effective Radiated Power	< 7 Watts	PASS	-
	§24.232(c)	Equivalent Isotropic Radiated Power	< 2 Watts	PASS	-
	§27.50(d)(4)	Equivalent Isotropic Radiated Power	< 1 Watts	PASS	-
3.5	§24.232(d)	Peak-to-Average Ratio	< 13 dB	PASS	-
3.6	§2.1049 §22.917(b) §24.238(b) §27.53(g)	Occupied Bandwidth	Reporting Only	PASS	-
3.7	§2.1051 §22.917(a) §24.238(a) §27.53(h)	Band Edge Measurement	< 43+10log10(P[Watts])	PASS	-
3.8	§2.1051 §22.917(a) §24.238(a) §27.53(h)	Conducted Emission	< 43+10log10(P[Watts])	PASS	-
3.9	§2.1055 §22.355	Frequency Stability for Temperature & Voltage	< 2.5 ppm for Part 22	PASS	-
	§2.1055 §24.235 §27.54		Within Authorized Band		



Report Section	FCC Rule	Description	Limit	Result	Remark
4.4	§2.1053 §22.917(a) §24.238(a) §27.53(h)	Field Strength of Spurious Radiation	$< 43+10\log_{10}(P[\text{Watts}])$	PASS	Under limit 6.50 dB at 1696.000 MHz



1 General Description

1.1 Applicant

ASUSTeK COMPUTER INC.
4F, No. 150, LI-TE RD., PEITOU, TAIPEI, TAIWAN

1.2 Manufacturer

COTEK ELECTRONICS (SUZHOU) CO., LTD.
No.288, Mayun Road, Suzhou Hi-and-New Tech Park, Jiangsu, PRC

1.3 Product Feature of Equipment Under Test

GSM/WCDMA/LTE, Bluetooth, Wi-Fi 2.4GHz 802.11b/g/n, Wi-Fi 5GHz 802.11a/n/ac, FM Receiver, NFC, and GPS.

Product Specification subjective to this standard	
Sample 1	EUT with SKU 1
Sample 2	EUT with SKU 2
Sample 3	EUT with SKU 3
Sample 4	EUT with SKU 4
Antenna Type	WWAN: PIFA Antenna WLAN: PIFA Antenna Bluetooth: PIFA Antenna GPS / Glonass / BDS / Galileo : PIFA Antenna NFC: Loop Antenna FM: Integral Antenna (Earphone acting as FM antenna deemed as an integral antenna)



<Sample Information>

SKU MB	SKU1	SKU2
DDR4X	6G/ Hynix	6G/ Hynix
UFS 2.1	128G/ Toshiba	64G/ Toshiba
CPU	MSM-8998	
TP Module	TIANMA/TA055VVHM09-03 ON CELL	TIANMA/TA055VVHM09-05 ON CELL
Front Camera	CHICONY/CBAH81120003870LH	CHICONY/CBAH81120003871LH
Rear Camera	12M+16M/SEMCO/MOMDM82PG3A	
Battery	ATL POLY/C11P1701/SMP	

SKU MB	SKU3	SKU4
DDR4X	6G/ Samsung	6G/ Hynix
UFS 2.1	256G/ Samsung	64G/ Samsung
CPU	MSM-8998	MSM-8998
TP Module	TIANMA/TA055VVHM08-05	TIANMA/TA055VVHM09-05
Front Camera	CHICONY/CBAH81120003871LH	
Rear Camera	12M+16M/SEMCO/MOMDM82PG3A	
Battery	ATL POLY/C11P1701/SMP	

1.4 Modification of EUT

No modifications are made to the EUT during all test items.



1.5 Testing Location

Sporton Lab is accredited to ISO 17025 by Taiwan Accreditation Foundation (TAF code : 1190) and the FCC designation No. TW0007 under the FCC 2.948(e) by Mutual Recognition Agreement (MRA) in FCC Test.

Test Site	SPORTON INTERNATIONAL INC.
Test Site Location	No. 52, Hwa Ya 1 st Rd., Hwa Ya Technology Park, Kwei-Shan District, Tao Yuan City, Taiwan, R.O.C. TEL: +886-3-327-3456 FAX: +886-3-328-4978
Test Site No.	Sporton Site No.
	TH03-HY

Test Site	SPORTON INTERNATIONAL INC.
Test Site Location	No.58, Aly. 75, Ln. 564, Wenhua 3rd Rd. Guishan Dist, Taoyuan City, Taiwan (R.O.C.) TEL: +886-3-327-0868 FAX: +886-3-327-0855
Test Site No.	Sporton Site No.
	03CH12-HY

Note: The test site complies with ANSI C63.4 2014 requirement.

1.6 Applicable Standards

According to the specifications of the manufacturer, the EUT must comply with the requirements of the following standards:

- ♦ 47 CFR Part 2, 22(H), 24(E), 27(L)
- ♦ ANSI / TIA / EIA-603-E-2016
- ♦ FCC KDB 971168 D01 Power Meas. License Digital Systems v02r02
- ♦ FCC KDB 412172 D01 Determining ERP and EIRP v01r01

Remark:

1. All test items were verified and recorded according to the standards and without any deviation during the test.
2. This EUT has also been tested and complied with the requirements of FCC Part 15, Subpart B, recorded in a separate test report.



2 Test Configuration of Equipment Under Test

2.1 Test Mode

Antenna port conducted and radiated test items were performed according to KDB 971168 D01 Power Meas. License Digital Systems v02r02 with maximum output power.

Radiated measurements were performed with rotating EUT in different three orthogonal test planes to find the maximum emission.

Radiated emissions were investigated as following frequency range:

1. 30 MHz to 9000 MHz for GSM850 and WCDMA Band V.
2. 30 MHz to 18000 MHz for WCDMA Band IV.
3. 30 MHz to 19100 MHz for GSM1900 and WCDMA Band II.

All modes and data rates and positions were investigated.

Test modes are chosen to be reported as the worst case configuration below:

Test Modes		
Band	Radiated TCs	Conducted TCs
GSM 850	<ul style="list-style-type: none"> ■ GSM Link ■ EDGE class 8 Link 	<ul style="list-style-type: none"> ■ GSM Link ■ EDGE class 8 Link
GSM 1900	<ul style="list-style-type: none"> ■ GPRS class 8 Link ■ EDGE class 8 Link 	<ul style="list-style-type: none"> ■ GPRS class 8 Link ■ EDGE class 8 Link
WCDMA Band V	<ul style="list-style-type: none"> ■ RMC 12.2Kbps Link 	<ul style="list-style-type: none"> ■ RMC 12.2Kbps Link
WCDMA Band II	<ul style="list-style-type: none"> ■ RMC 12.2Kbps Link 	<ul style="list-style-type: none"> ■ RMC 12.2Kbps Link
WCDMA Band IV	<ul style="list-style-type: none"> ■ RMC 12.2Kbps Link 	<ul style="list-style-type: none"> ■ RMC 12.2Kbps Link

2.2 Connection Diagram of Test System

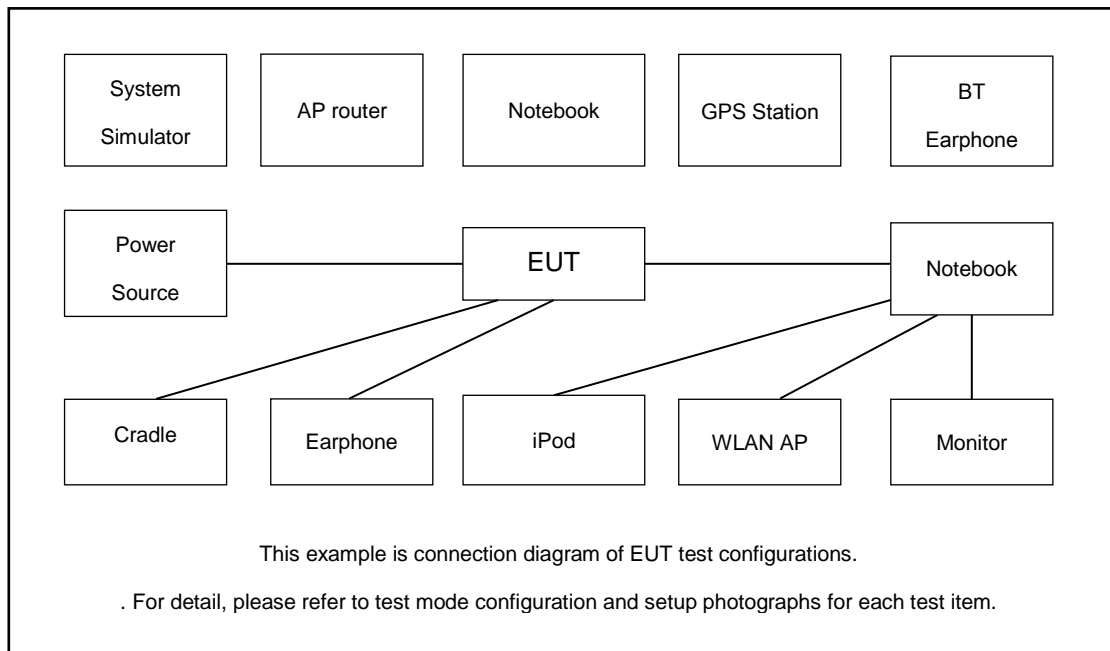

2.3 Support Unit used in test configuration

Item	Equipment	Trade Name	Model No.	FCC ID	Data Cable	Power Cord
1.	Base Station	R&S	CMU 200	N/A	N/A	Unshielded, 1.8 m

2.4 Measurement Results Explanation Example

For all conducted test items:

The offset level is set in the spectrum analyzer to compensate the RF cable loss and attenuator factor between RF conducted output port and spectrum analyzer. With the offset compensation, the spectrum analyzer reading level will be exactly the RF output level.

The spectrum analyzer offset is derived from RF cable loss and attenuator factor.

Offset = RF cable loss + attenuator factor.

The following shows an offset computation example with RF cable loss 4.2 dB and a 10dB attenuator.

Example :

$$\begin{aligned} \text{Offset(dB)} &= \text{RF cable loss(dB)} + \text{attenuator factor(dB)} \\ &= 4.2 + 10 = 14.2 \text{ (dB)} \end{aligned}$$



2.5 Frequency List of Low/Middle/High Channels

Frequency List				
Band	Channel/Frequency(MHz)	Lowest	Middle	Highest
GSM850	Channel	128	189	251
	Frequency	824.2	836.4	848.8
WCDMA Band V	Channel	4132	4182	4233
	Frequency	826.4	836.4	846.6
GSM1900	Channel	512	661	810
	Frequency	1850.2	1880.0	1909.8
WCDMA Band II	Channel	9262	9400	9538
	Frequency	1852.4	1880.0	1907.6
WCDMA Band IV	Channel	1312	1413	1513
	Frequency	1712.4	1732.6	1752.6

3 Conducted Test Result

3.1 Measuring Instruments

See list of measuring instruments of this test report.

3.2 Test Setup

3.2.1 Conducted Output Power



3.2.2 Peak-to-Average Ratio, Occupied Bandwidth, Conducted Band-Edge and Conducted Spurious Emission

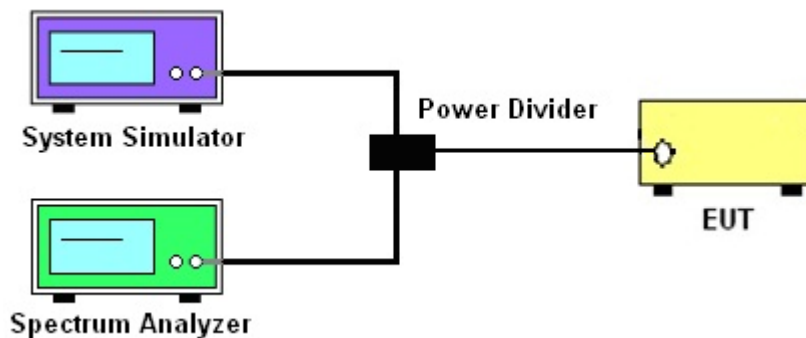

3.2.3 Frequency Stability

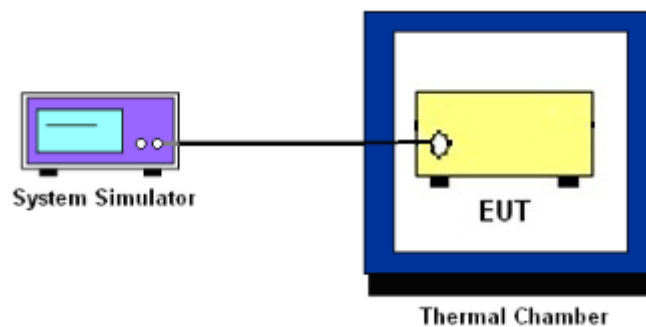

3.3 Test Result of Conducted Test

Please refer to Appendix A.



3.4 Conducted Output Power and ERP/EIRP

3.4.1 Description of the Conducted Output Power and ERP/EIRP

A system simulator was used to establish communication with the EUT. Its parameters were set to enforce EUT transmitting at the maximum power. The measured power in the radio frequency on the transmitter output terminals shall be reported.

The ERP of mobile transmitters must not exceed 7 Watts for GSM850 and WCDMA Band V.

The EIRP of mobile transmitters must not exceed 2 Watts for GSM1900 and WCDMA Band II.

The EIRP of mobile transmitters must not exceed 1 Watts for WCDMA Band IV.

According to KDB 412172 D01 Power Approach,

$EIRP = P_T + G_T - L_C$, $ERP = EIRP - 2.15$, where

P_T = transmitter output power in dBm

G_T = gain of the transmitting antenna in dBi

L_C = signal attenuation in the connecting cable between the transmitter and antenna in dB

3.4.2 Test Procedures

1. The transmitter output port was connected to the system simulator.
2. Set EUT at maximum power through system simulator.
3. Select lowest, middle, and highest channels for each band and different modulation.
4. Measure the maximum burst average power for GSM and maximum average power for other modulation signal.



3.5 Peak-to-Average Ratio

3.5.1 Description of the PAR Measurement

The peak-to-average ratio (PAR) of the transmission may not exceed 13 dB.

3.5.2 Test Procedures

1. The testing follows FCC KDB 971168 D01 v02r02 Section 5.7.1.
2. The EUT was connected to spectrum analyzer and system simulator via a power divider.
3. Set EUT to transmit at maximum output power.
4. When the duty cycle is less than 98%, then signal gating will be implemented on the spectrum analyzer by triggering from the system simulator.
5. Set the CCDF (Complementary Cumulative Distribution Function) option of the spectrum analyzer.
Record the maximum PAPR level associated with a probability of 0.1%.



3.6 99% Occupied Bandwidth and 26dB Bandwidth Measurement

3.6.1 Description of 99% Occupied Bandwidth and 26dB Bandwidth Measurement

The occupied bandwidth is the width of a frequency band such that, below the lower and above the upper frequency limits, the mean powers emitted are each equal to a specified percentage 0.5% of the total mean transmitted power.

The 26 dB emission bandwidth is defined as the frequency range between two points, one above and one below the carrier frequency, at which the spectral density of the emission is attenuated 26 dB below the maximum in-band spectral density of the modulated signal. Spectral density (power per unit bandwidth) is to be measured with a detector of resolution bandwidth equal to approximately 1.0% of the emission bandwidth.

3.6.2 Test Procedures

1. The testing follows FCC KDB 971168 v02r02 Section 4.2.
2. The EUT was connected to spectrum analyzer and system simulator via a power divider.
3. The spectrum analyzer center frequency is set to the nominal EUT channel center frequency. The span range for the spectrum analyzer shall be between two and five times the anticipated OBW.
4. The nominal resolution bandwidth (RBW) shall be in the range of 1 to 5 % of the anticipated OBW, and the VBW shall be at least 3 times the RBW.
5. Set the detection mode to peak, and the trace mode to max hold.
6. Determine the reference value: Set the EUT to transmit a modulated signal. Allow the trace to stabilize. Set the spectrum analyzer marker to the highest level of the displayed trace.
(this is the reference value)
7. Determine the “-26 dB down amplitude” as equal to (Reference Value – X).
8. Place two markers, one at the lowest and the other at the highest frequency of the envelope of the spectral display such that each marker is at or slightly below the “-X dB down amplitude” determined in step 6. If a marker is below this “-X dB down amplitude” value it shall be placed as close as possible to this value. The OBW is the positive frequency difference between the two markers.
9. Use the 99 % power bandwidth function of the spectrum analyzer and report the measured bandwidth.



3.7 Conducted Band Edge

3.7.1 Description of Conducted Band Edge Measurement

The power of any emission outside of the authorized operating frequency ranges must be lower than the transmitter power (P) by a factor of at least $43 + 10 \log (P)$ dB.

3.7.2 Test Procedures

1. The testing follows FCC KDB 971168 D01 v02r02 Section 6.0.
2. The EUT was connected to the spectrum analyzer and system simulator via a power divider.
3. The RF output of EUT was connected to the spectrum analyzer by an RF cable and attenuator. The path loss was compensated to the results for each measurement.
4. The band edges of low and high channels for the highest RF powers were measured.
5. The RF fundamental frequency should be excluded against the limit line in the operating frequency band.
6. The limit line is derived from $43 + 10\log(P)$ dB below the transmitter power P(Watts)



3.8 Conducted Spurious Emission

3.8.1 Description of Conducted Spurious Emission Measurement

The power of any emission outside of the authorized operating frequency ranges must be lower than the transmitter power (P) by a factor of at least $43 + 10 \log (P)$ dB.

It is measured by means of a calibrated spectrum analyzer and scanned from 30 MHz up to a frequency including its 10th harmonic.

3.8.2 Test Procedures

1. The testing follows FCC KDB 971168 D01 v02r02 Section 6.0.
2. The EUT was connected to the spectrum analyzer and system simulator via a power divider.
3. The RF output of EUT was connected to the spectrum analyzer by an RF cable and attenuator. The path loss was compensated to the results for each measurement.
4. The middle channel for the highest RF power within the transmitting frequency was measured.
5. The conducted spurious emission for the whole frequency range was taken.
6. The RF fundamental frequency should be excluded against the limit line in the operating frequency band.
7. The limit line is derived from $43 + 10\log(P)$ dB below the transmitter power P(Watts)



3.9 Frequency Stability

3.9.1 Description of Frequency Stability Measurement

The frequency stability shall be measured by variation of ambient temperature and variation of primary supply voltage to ensure that the fundamental emission stays within the authorized frequency block. The frequency stability of the transmitter shall be maintained within $\pm 0.00025\%$ ($\pm 2.5\text{ppm}$) of the center frequency.

3.9.2 Test Procedures for Temperature Variation

1. The testing follows FCC KDB 971168 D01 v02r02 Section 9.0.
2. The EUT was set up in the thermal chamber and connected with the system simulator.
3. With power OFF, the temperature was decreased to -30°C and the EUT was stabilized before testing. Power was applied and the maximum change in frequency was recorded within one minute.
4. With power OFF, the temperature was raised in 10°C steps up to 50°C . The EUT was stabilized at each step for at least half an hour. Power was applied and the maximum frequency change was recorded within one minute.

3.9.3 Test Procedures for Voltage Variation

1. The testing follows FCC KDB 971168 D01 v02r02 Section 9.0.
2. The EUT was placed in a temperature chamber at $20\pm 5^{\circ}\text{C}$ and connected with the system simulator.
3. The power supply voltage to the EUT was varied from 85% to 115% of the nominal value measured at the input to the EUT.
4. The variation in frequency was measured for the worst case.

4 Radiated Test Items

4.1 Measuring Instruments

See list of measuring instruments of this test report.

4.2 Test Setup

4.2.1 For radiated test from 30MHz to 1GHz



4.2.2 For radiated test above 1GHz

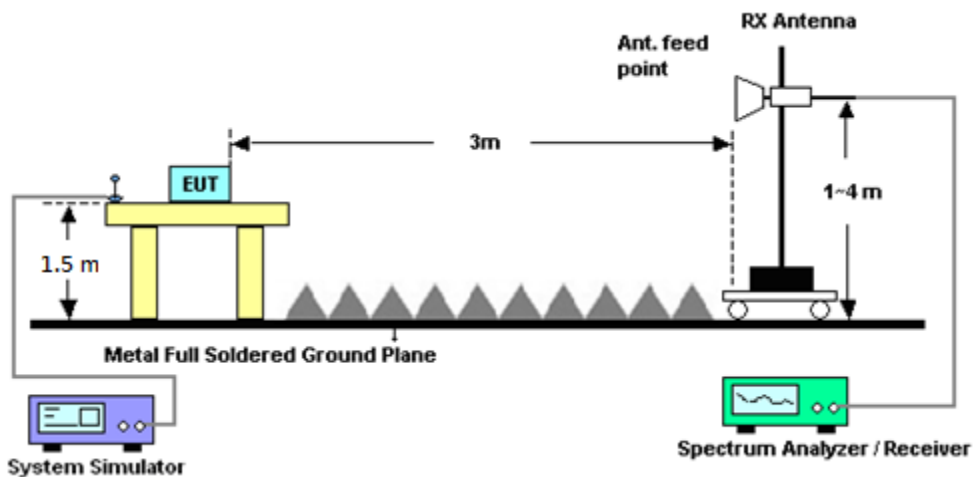

4.3 Test Result of Radiated Test

Please refer to Appendix B.



4.4 Field Strength of Spurious Radiation Measurement

4.4.1 Description of Field Strength of Spurious Radiated Measurement

The power of any emission outside of the authorized operating frequency ranges must be attenuated below the transmitter power (P) by a factor of at least $43 + 10 \log (P)$ dB. The spectrum is scanned from 30 MHz up to a frequency including its 10th harmonic.

4.4.2 Test Procedures

1. The testing follows FCC KDB 971168 D01 v02r02 Section 5.8 and ANSI / TIA-603-E-2016 Section 2.2.12.
2. The EUT was placed on a rotatable wooden table 0.8 meters for frequency below 1GHz and 1.5 meter for frequency above 1GHz above the ground.
3. The EUT was set 3 meters from the receiving antenna, which was mounted on the antenna tower.
4. The table was rotated 360 degrees to determine the position of the highest spurious emission.
5. The height of the receiving antenna is varied between one meter and four meters to search for the maximum spurious emission for both horizontal and vertical polarizations.
6. Make the measurement with the spectrum analyzer's RBW = 1MHz, VBW = 3MHz, taking record of maximum spurious emission.
7. A horn antenna was substituted in place of the EUT and was driven by a signal generator.
8. Tune the output power of signal generator to the same emission level with EUT maximum spurious emission.
9. Taking the record of output power at antenna port.
10. Repeat step 7 to step 8 for another polarization.
11. $EIRP \text{ (dBm)} = S.G. \text{ Power} - Tx \text{ Cable Loss} + Tx \text{ Antenna Gain}$
12. $ERP \text{ (dBm)} = EIRP - 2.15$
13. The RF fundamental frequency should be excluded against the limit line in the operating frequency band.
14. The limit line is derived from $43 + 10\log(P)$ dB below the transmitter power P(Watts)



5 List of Measuring Equipment

Instrument	Manufacturer	Model No.	Serial No.	Characteristics	Calibration Date	Test Date	Due Date	Remark
Spectrum Analyzer	Rohde & Schwarz	FSP30	101329	9kHz~30GHz	Jun. 29, 2017	Sep. 13, 2017	Jun. 28, 2018	Conducted (TH03-HY)
Temperature Chamber	ESPEC	SU-641	92013721	-30°C ~70°C	Nov. 16, 2016	Sep. 13, 2017	Nov. 15, 2017	Conducted (TH03-HY)
Programmable Power Supply	GW Instek	PSS-2005	EL883644	Voltage:0~20V;Current:0~5A	Nov. 22, 2016	Sep. 13, 2017	Nov. 21, 2017	Conducted (TH03-HY)
Base Station(Measu	Rohde & Schwarz	CMU200	117995	GSM / GPRS / WCDMA / CDMA	Aug. 09, 2017	Sep. 13, 2017	Aug. 08, 2018	Conducted (TH03-HY)
Amplifier	MITEQ	TTA1840-35-HG	1871923	18GHz~40GHz,VS WR : 2.5:1 max	Jul. 18, 2017	Sep. 01, 2017 ~ Sep. 18, 2017	Jul. 17, 2018	Radiation (03CH12-HY)
Bilog Antenna	TESEQ	CBL 6111D&008	37059&01	30MHz~1GHz	Oct. 15, 2016	Sep. 01, 2017 ~ Sep. 18, 2017	Oct. 14, 2017	Radiation (03CH12-HY)
EMI Test Receiver	Rohde & Schwarz	ESU26	100390	20Hz~26.5GHz	Dec. 23, 2016	Sep. 01, 2017 ~ Sep. 18, 2017	Dec. 22, 2017	Radiation (03CH12-HY)
Horn Antenna	SCHWARZBECK	BBHA 9120D	9120D-1328	1GHz ~ 18GHz	Oct. 25, 2016	Sep. 01, 2017 ~ Sep. 18, 2017	Oct. 24, 2017	Radiation (03CH12-HY)
Preamplifier	COM-POWER	PA-103	161075	10MHz~1GHz	Mar. 23, 2017	Sep. 01, 2017 ~ Sep. 18, 2017	Mar. 22, 2018	Radiation (03CH12-HY)
Preamplifier	MITEQ	AMF-7D-00 101800-30-1	1815698	1GHz~18GHz	Dec. 01, 2016	Sep. 01, 2017 ~ Sep. 18, 2017	Nov. 30, 2017	Radiation (03CH12-HY)
Antenna Mast	EMEC	AM-BS-450 0-B	N/A	1m~4m	N/A	Sep. 01, 2017 ~ Sep. 18, 2017	N/A	Radiation (03CH12-HY)
Turn Table	EMEC	TT2000	N/A	0~360 Degree	N/A	Sep. 01, 2017 ~ Sep. 18, 2017	N/A	Radiation (03CH12-HY)
Attenuator	Fairview Microwave	SA18S5W-10	n/a	10db	Mar. 24, 2017	Sep. 01, 2017 ~ Sep. 18, 2017	Mar. 23, 2018	Radiation (03CH12-HY)
SHF-EHF Horn Antenna	SCHWARZBECK	BBHA 9170	BBHA9170576	18GHz ~ 40GHz	Apr. 27, 2017	Sep. 01, 2017 ~ Sep. 18, 2017	Apr. 26, 2018	Radiation (03CH12-HY)
Horn Antenna	SCHWARZBECK	BBHA 9120 D	BBHA 9120 D 1212	1GHz ~ 18GHz	Mar. 17, 2017	Sep. 01, 2017 ~ Sep. 18, 2017	Mar. 16, 2018	Radiation (03CH12-HY)
SHF-EHF Horn Antenna	SCHWARZBECK	BBHA 9170	BBHA9170584	18GHz- 40GHz	Nov. 08, 2016	Sep. 01, 2017 ~ Sep. 18, 2017	Nov. 07, 2017	Radiation (03CH12-HY)
Signal Generator	Anritsu	MG3694C	163401	0.1Hz~40GHz	Jan. 04, 2017	Sep. 01, 2017 ~ Sep. 18, 2017	Jan. 03, 2018	Radiation (03CH12-HY)



6 Uncertainty of Evaluation

Uncertainty of Radiated Emission Measurement (30 MHz ~ 1000 MHz)

Measuring Uncertainty for a Level of Confidence of 95% ($U = 2Uc(y)$)	3.36
---	------

Uncertainty of Radiated Emission Measurement (1 GHz ~ 40 GHz)

Measuring Uncertainty for a Level of Confidence of 95% ($U = 2Uc(y)$)	3.70
---	------

Uncertainty of Radiated Emission Measurement (18 GHz ~ 40 GHz)

Measuring Uncertainty for a Level of Confidence of 95% ($U = 2Uc(y)$)	3.98
---	------



Appendix A. Test Results of Conducted Test

Conducted Output Power(Average power)

Conducted Power (*Unit: dBm)						
Band	GSM850			GSM1900		
Channel	128	189	251	512	661	810
Frequency	824.2	836.4	848.8	1850.2	1880	1909.8
GSM	32.85	32.85	33.00	29.52	29.57	29.96
GPRS class 8	32.78	32.78	32.93	29.52	29.59	29.97
GPRS class 10	29.86	30.00	30.31	26.96	26.99	27.14
GPRS class 11	27.93	28.08	28.39	25.07	25.09	25.22
GPRS class 12	26.48	26.69	26.74	23.59	23.63	23.82
EGPRS class 8	26.71	26.83	26.91	25.68	25.60	25.79
EGPRS class 10	23.53	23.65	23.74	22.62	22.58	22.82
EGPRS class 11	21.65	21.75	21.82	20.77	20.70	20.89
EGPRS class 12	20.27	20.30	20.41	19.35	19.32	19.52

Conducted Power (*Unit: dBm)						
Band	WCDMA Band V			WCDMA Band II		
Channel	4132	4182	4233	9262	9400	9538
Frequency	826.4	836.4	846.6	1852.4	1880	1907.6
RMC 12.2K	22.81	22.77	22.73	21.35	21.27	21.29
HSDPA Subtest-1	21.84	21.79	21.76	20.34	20.33	20.34
HSDPA Subtest-2	21.84	21.76	21.50	20.42	20.34	20.42
HSDPA Subtest-3	21.37	21.32	21.34	19.89	19.85	19.87
HSDPA Subtest-4	21.27	21.31	21.34	19.90	19.86	19.89
HSUPA Subtest-1	21.80	21.80	21.71	20.17	20.20	20.16
HSUPA Subtest-2	19.83	19.78	19.76	18.10	18.22	18.13
HSUPA Subtest-3	20.77	20.80	20.71	19.11	19.22	19.14
HSUPA Subtest-4	19.83	19.75	19.68	18.12	18.21	18.11
HSUPA Subtest-5	21.80	21.80	21.80	20.20	20.20	20.10



Conducted Power (*Unit: dBm)			
Band	WCDMA Band IV		
Channel	1312	1413	1513
Frequency	1712.4	1732.6	1752.6
RMC 12.2K	21.34	21.46	21.29
HSDPA Subtest-1	20.40	20.47	20.31
HSDPA Subtest-2	20.41	20.45	20.28
HSDPA Subtest-3	19.92	19.96	19.80
HSDPA Subtest-4	19.89	19.97	19.79
HSUPA Subtest-1	20.16	20.20	20.11
HSUPA Subtest-2	18.15	18.22	18.19
HSUPA Subtest-3	19.17	19.19	19.19
HSUPA Subtest-4	18.17	18.20	18.20
HSUPA Subtest-5	20.20	20.30	20.20



A1. GSM

Peak-to-Average Ratio

Mode	GSM850		Limit: 13dB
Mod.	GSM	EDGE class 8	Result
Lowest CH	0.56	3.40	PASS
Middle CH	0.52	3.32	
Highest CH	0.52	3.24	

Mode	GSM1900		Limit: 13dB
Mod.	GPRS class 8	EDGE class 8	Result
Lowest CH	0.44	3.48	PASS
Middle CH	0.44	3.64	
Highest CH	0.48	3.64	

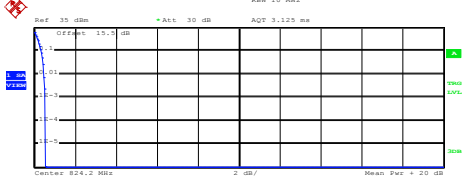
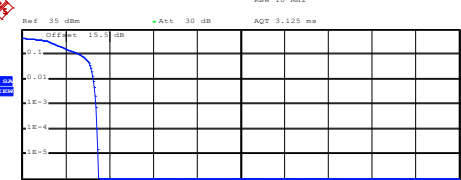
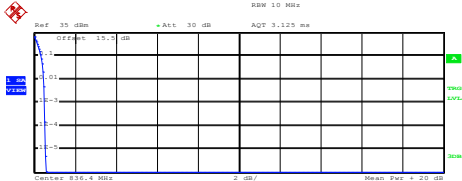
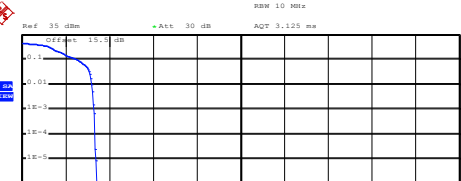
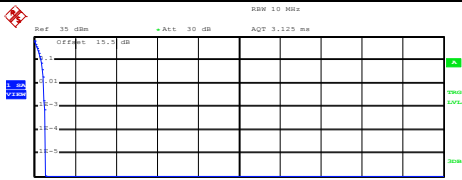
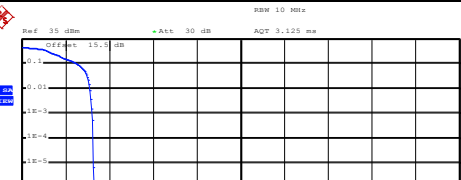

GSM	GSM850 (EDGE class 8)																
<p align="center">Lowest Channel</p>  <p>Ref: 35 dBm, Att: 30 dB, AQT: 3.125 ms, RBW: 10 MHz, Center: 824.2 MHz, Mean Pwr: +20 dB</p> <p>Complementary Cumulative Distribution Function (100000 samples)</p> <p>Trace 1</p> <p>Mean 32.17 dBm Peak 32.71 dBm Crest 0.54 dB</p> <table border="0"> <tr><td>10 %</td><td>0.36 dB</td></tr> <tr><td>1 %</td><td>0.48 dB</td></tr> <tr><td>.1 %</td><td>0.56 dB</td></tr> <tr><td>.01 %</td><td>0.56 dB</td></tr> </table> <p>Date: 18.SEP.2017 14:56:34</p>	10 %	0.36 dB	1 %	0.48 dB	.1 %	0.56 dB	.01 %	0.56 dB	<p align="center">Lowest Channel</p>  <p>Ref: 35 dBm, Att: 30 dB, AQT: 3.125 ms, RBW: 10 MHz, Center: 824.2 MHz, Mean Pwr: +20 dB</p> <p>Complementary Cumulative Distribution Function (100000 samples)</p> <p>Trace 1</p> <p>Mean 25.28 dBm Peak 28.76 dBm Crest 3.48 dB</p> <table border="0"> <tr><td>10 %</td><td>2.68 dB</td></tr> <tr><td>1 %</td><td>3.28 dB</td></tr> <tr><td>.1 %</td><td>3.40 dB</td></tr> <tr><td>.01 %</td><td>3.44 dB</td></tr> </table> <p>Date: 14.SEP.2017 11:48:05</p>	10 %	2.68 dB	1 %	3.28 dB	.1 %	3.40 dB	.01 %	3.44 dB
10 %	0.36 dB																
1 %	0.48 dB																
.1 %	0.56 dB																
.01 %	0.56 dB																
10 %	2.68 dB																
1 %	3.28 dB																
.1 %	3.40 dB																
.01 %	3.44 dB																
<p align="center">Middle Channel</p>  <p>Ref: 35 dBm, Att: 30 dB, AQT: 3.125 ms, RBW: 10 MHz, Center: 836.4 MHz, Mean Pwr: +20 dB</p> <p>Complementary Cumulative Distribution Function (100000 samples)</p> <p>Trace 1</p> <p>Mean 32.08 dBm Peak 32.64 dBm Crest 0.56 dB</p> <table border="0"> <tr><td>10 %</td><td>0.32 dB</td></tr> <tr><td>1 %</td><td>0.48 dB</td></tr> <tr><td>.1 %</td><td>0.52 dB</td></tr> <tr><td>.01 %</td><td>0.52 dB</td></tr> </table> <p>Date: 18.SEP.2017 14:57:05</p>	10 %	0.32 dB	1 %	0.48 dB	.1 %	0.52 dB	.01 %	0.52 dB	<p align="center">Middle Channel</p>  <p>Ref: 35 dBm, Att: 30 dB, AQT: 3.125 ms, RBW: 10 MHz, Center: 836.4 MHz, Mean Pwr: +20 dB</p> <p>Complementary Cumulative Distribution Function (100000 samples)</p> <p>Trace 1</p> <p>Mean 25.20 dBm Peak 28.62 dBm Crest 3.41 dB</p> <table border="0"> <tr><td>10 %</td><td>2.56 dB</td></tr> <tr><td>1 %</td><td>3.20 dB</td></tr> <tr><td>.1 %</td><td>3.32 dB</td></tr> <tr><td>.01 %</td><td>3.36 dB</td></tr> </table> <p>Date: 14.SEP.2017 11:48:26</p>	10 %	2.56 dB	1 %	3.20 dB	.1 %	3.32 dB	.01 %	3.36 dB
10 %	0.32 dB																
1 %	0.48 dB																
.1 %	0.52 dB																
.01 %	0.52 dB																
10 %	2.56 dB																
1 %	3.20 dB																
.1 %	3.32 dB																
.01 %	3.36 dB																
<p align="center">Highest Channel</p>  <p>Ref: 35 dBm, Att: 30 dB, AQT: 3.125 ms, RBW: 10 MHz, Center: 848.8 MHz, Mean Pwr: +20 dB</p> <p>Complementary Cumulative Distribution Function (100000 samples)</p> <p>Trace 1</p> <p>Mean 32.09 dBm Peak 32.64 dBm Crest 0.55 dB</p> <table border="0"> <tr><td>10 %</td><td>0.32 dB</td></tr> <tr><td>1 %</td><td>0.48 dB</td></tr> <tr><td>.1 %</td><td>0.52 dB</td></tr> <tr><td>.01 %</td><td>0.56 dB</td></tr> </table> <p>Date: 18.SEP.2017 14:57:28</p>	10 %	0.32 dB	1 %	0.48 dB	.1 %	0.52 dB	.01 %	0.56 dB	<p align="center">Highest Channel</p>  <p>Ref: 35 dBm, Att: 30 dB, AQT: 3.125 ms, RBW: 10 MHz, Center: 848.8 MHz, Mean Pwr: +20 dB</p> <p>Complementary Cumulative Distribution Function (100000 samples)</p> <p>Trace 1</p> <p>Mean 25.42 dBm Peak 28.69 dBm Crest 3.27 dB</p> <table border="0"> <tr><td>10 %</td><td>2.56 dB</td></tr> <tr><td>1 %</td><td>3.12 dB</td></tr> <tr><td>.1 %</td><td>3.24 dB</td></tr> <tr><td>.01 %</td><td>3.28 dB</td></tr> </table> <p>Date: 14.SEP.2017 11:48:49</p>	10 %	2.56 dB	1 %	3.12 dB	.1 %	3.24 dB	.01 %	3.28 dB
10 %	0.32 dB																
1 %	0.48 dB																
.1 %	0.52 dB																
.01 %	0.56 dB																
10 %	2.56 dB																
1 %	3.12 dB																
.1 %	3.24 dB																
.01 %	3.28 dB																

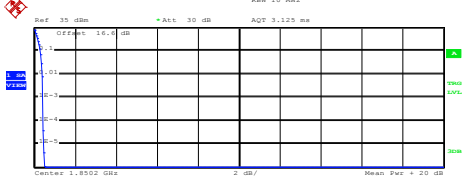
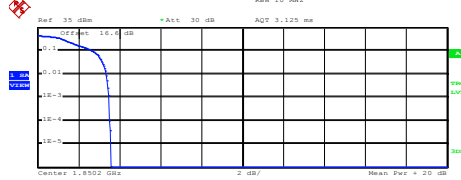
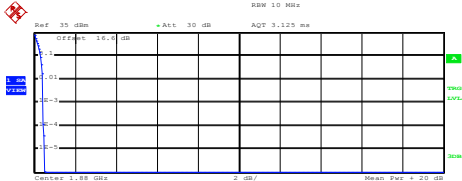
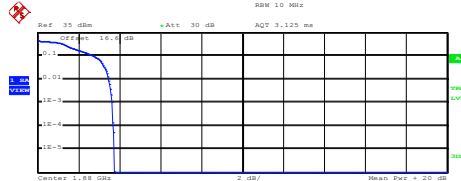
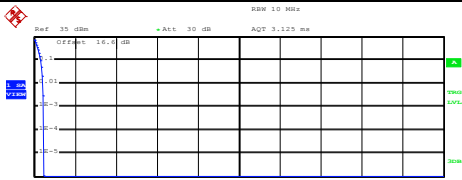
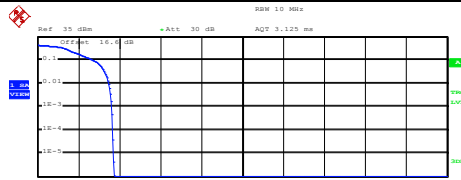

GSM1900 (GPRS class 8)	GSM1900 (EDGE class 8)																
<p align="center">Lowest Channel</p>  <p>Center 1.8502 GHz 2 dB/ Mean Pwr + 20 dB</p> <p>Complementary Cumulative Distribution Function (100000 samples) Trace 1 Mean 29.41 dBm Peak 29.89 dBm Crest 0.48 dB</p> <table border="1"> <tr><td>10 %</td><td>0.28 dB</td></tr> <tr><td>1 %</td><td>0.40 dB</td></tr> <tr><td>.1 %</td><td>0.44 dB</td></tr> <tr><td>.01 %</td><td>0.44 dB</td></tr> </table> <p>Date: 14.SEP.2017 12:03:11</p>	10 %	0.28 dB	1 %	0.40 dB	.1 %	0.44 dB	.01 %	0.44 dB	<p align="center">Lowest Channel</p>  <p>Center 1.8502 GHz 2 dB/ Mean Pwr + 20 dB</p> <p>Complementary Cumulative Distribution Function (100000 samples) Trace 1 Mean 24.83 dBm Peak 28.41 dBm Crest 3.58 dB</p> <table border="1"> <tr><td>10 %</td><td>2.72 dB</td></tr> <tr><td>1 %</td><td>3.36 dB</td></tr> <tr><td>.1 %</td><td>3.48 dB</td></tr> <tr><td>.01 %</td><td>3.52 dB</td></tr> </table> <p>Date: 14.SEP.2017 12:37:17</p>	10 %	2.72 dB	1 %	3.36 dB	.1 %	3.48 dB	.01 %	3.52 dB
10 %	0.28 dB																
1 %	0.40 dB																
.1 %	0.44 dB																
.01 %	0.44 dB																
10 %	2.72 dB																
1 %	3.36 dB																
.1 %	3.48 dB																
.01 %	3.52 dB																
<p align="center">Middle Channel</p>  <p>Center 1.88 GHz 2 dB/ Mean Pwr + 20 dB</p> <p>Complementary Cumulative Distribution Function (100000 samples) Trace 1 Mean 29.39 dBm Peak 29.89 dBm Crest 0.50 dB</p> <table border="1"> <tr><td>10 %</td><td>0.32 dB</td></tr> <tr><td>1 %</td><td>0.40 dB</td></tr> <tr><td>.1 %</td><td>0.44 dB</td></tr> <tr><td>.01 %</td><td>0.44 dB</td></tr> </table> <p>Date: 14.SEP.2017 12:03:26</p>	10 %	0.32 dB	1 %	0.40 dB	.1 %	0.44 dB	.01 %	0.44 dB	<p align="center">Middle Channel</p>  <p>Center 1.88 GHz 2 dB/ Mean Pwr + 20 dB</p> <p>Complementary Cumulative Distribution Function (100000 samples) Trace 1 Mean 24.81 dBm Peak 28.55 dBm Crest 3.74 dB</p> <table border="1"> <tr><td>10 %</td><td>2.76 dB</td></tr> <tr><td>1 %</td><td>3.48 dB</td></tr> <tr><td>.1 %</td><td>3.64 dB</td></tr> <tr><td>.01 %</td><td>3.68 dB</td></tr> </table> <p>Date: 14.SEP.2017 12:37:35</p>	10 %	2.76 dB	1 %	3.48 dB	.1 %	3.64 dB	.01 %	3.68 dB
10 %	0.32 dB																
1 %	0.40 dB																
.1 %	0.44 dB																
.01 %	0.44 dB																
10 %	2.76 dB																
1 %	3.48 dB																
.1 %	3.64 dB																
.01 %	3.68 dB																
<p align="center">Highest Channel</p>  <p>Center 1.9098 GHz 2 dB/ Mean Pwr + 20 dB</p> <p>Complementary Cumulative Distribution Function (100000 samples) Trace 1 Mean 29.44 dBm Peak 29.89 dBm Crest 0.45 dB</p> <table border="1"> <tr><td>10 %</td><td>0.32 dB</td></tr> <tr><td>1 %</td><td>0.44 dB</td></tr> <tr><td>.1 %</td><td>0.48 dB</td></tr> <tr><td>.01 %</td><td>0.48 dB</td></tr> </table> <p>Date: 14.SEP.2017 12:03:42</p>	10 %	0.32 dB	1 %	0.44 dB	.1 %	0.48 dB	.01 %	0.48 dB	<p align="center">Highest Channel</p>  <p>Center 1.9098 GHz 2 dB/ Mean Pwr + 20 dB</p> <p>Complementary Cumulative Distribution Function (100000 samples) Trace 1 Mean 24.83 dBm Peak 28.55 dBm Crest 3.72 dB</p> <table border="1"> <tr><td>10 %</td><td>2.76 dB</td></tr> <tr><td>1 %</td><td>3.48 dB</td></tr> <tr><td>.1 %</td><td>3.64 dB</td></tr> <tr><td>.01 %</td><td>3.68 dB</td></tr> </table> <p>Date: 14.SEP.2017 12:37:55</p>	10 %	2.76 dB	1 %	3.48 dB	.1 %	3.64 dB	.01 %	3.68 dB
10 %	0.32 dB																
1 %	0.44 dB																
.1 %	0.48 dB																
.01 %	0.48 dB																
10 %	2.76 dB																
1 %	3.48 dB																
.1 %	3.64 dB																
.01 %	3.68 dB																



26dB Bandwidth

Mode	GSM850	
Mod.	GSM	EDGE class 8
Lowest CH	0.310	0.296
Middle CH	0.311	0.292
Highest CH	0.311	0.289

Mode	GSM1900	
Mod.	GPRS class 8	EDGE class 8
Lowest CH	0.296	0.300
Middle CH	0.309	0.310
Highest CH	0.315	0.309

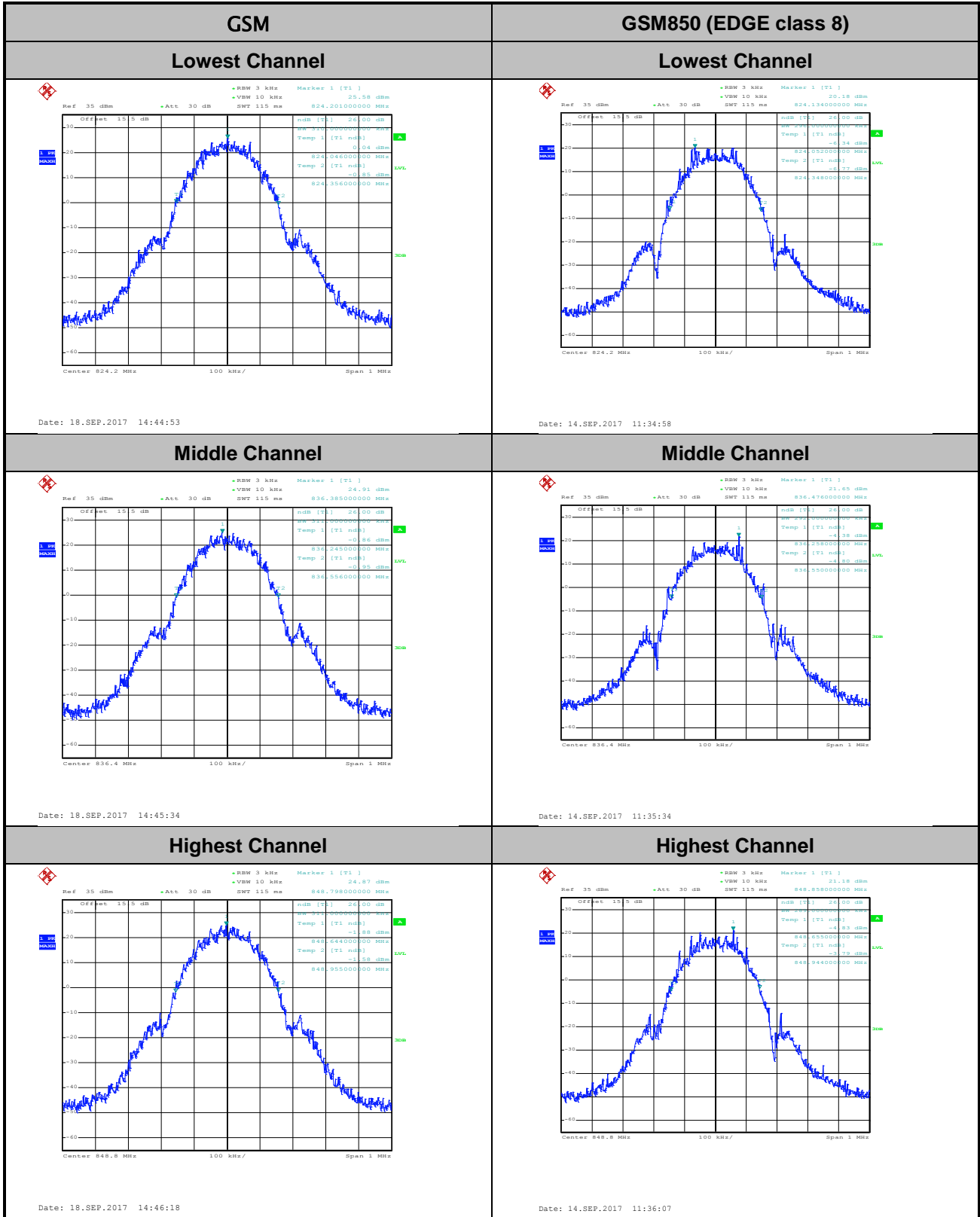

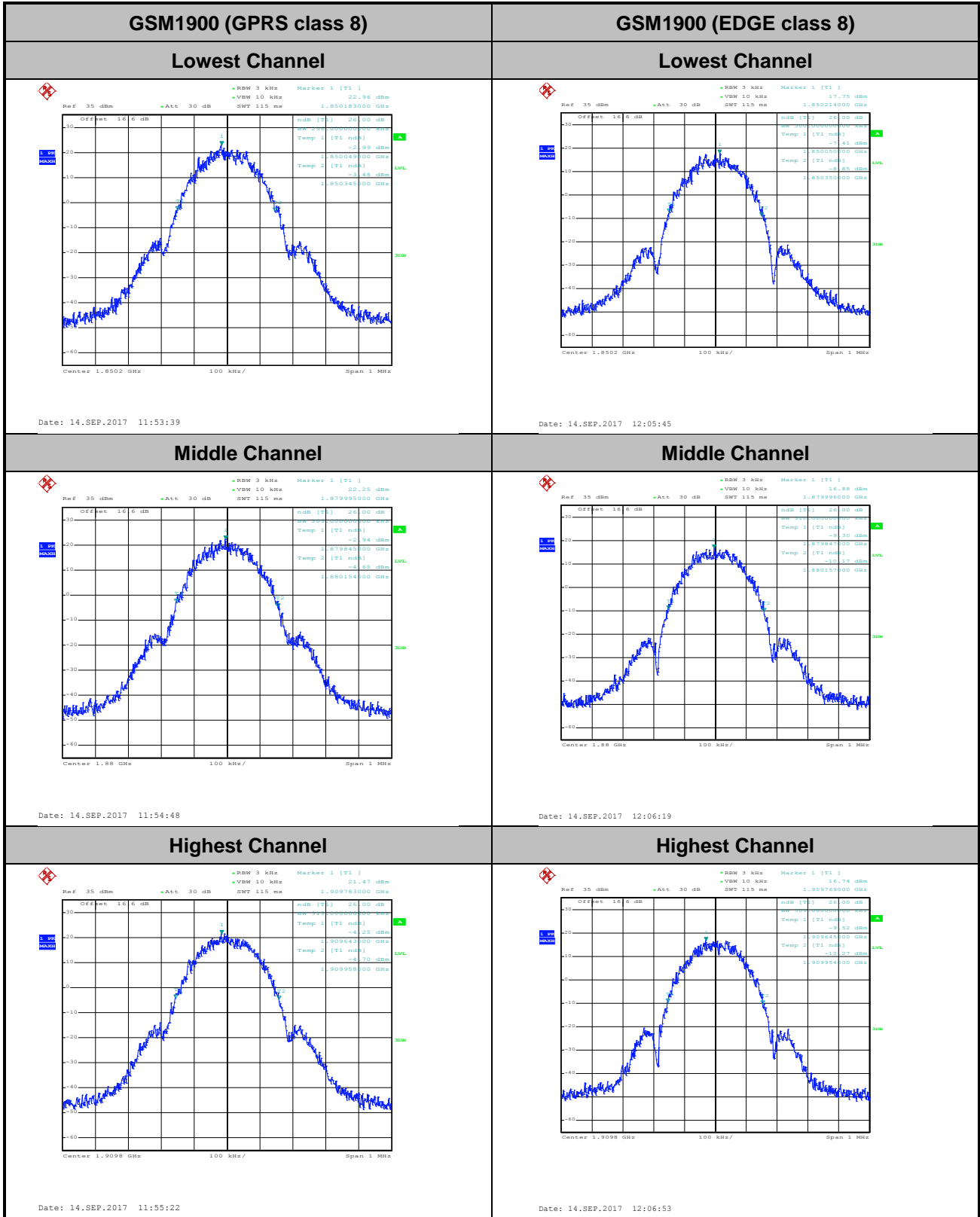



Occupied Bandwidth

Mode	GSM850	
Mod.	GSM	EDGE class 8
Lowest CH	0.246	0.241
Middle CH	0.242	0.236
Highest CH	0.246	0.235

Mode	GSM1900	
Mod.	GPRS class 8	EDGE class 8
Lowest CH	0.244	0.245
Middle CH	0.244	0.248
Highest CH	0.247	0.244

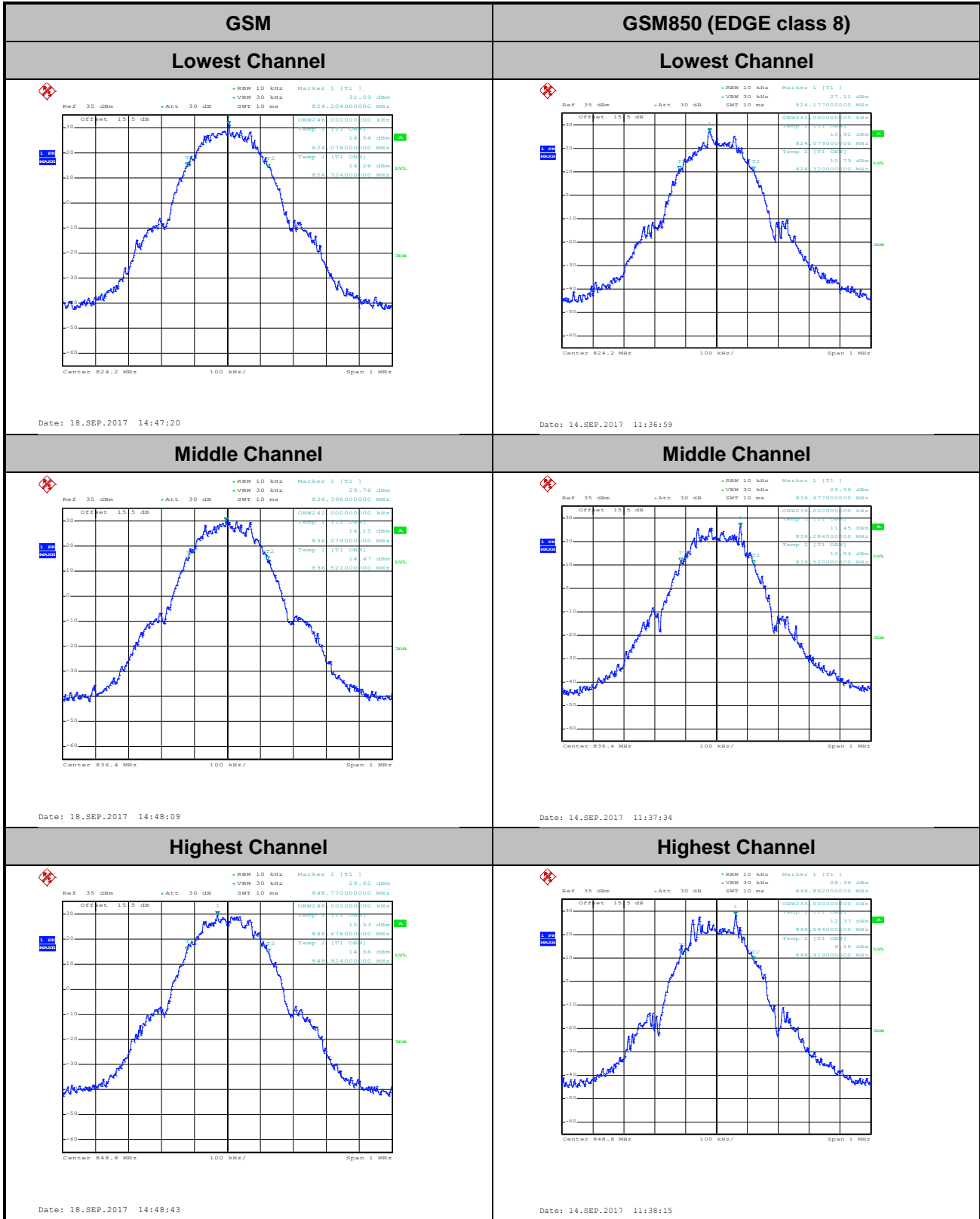

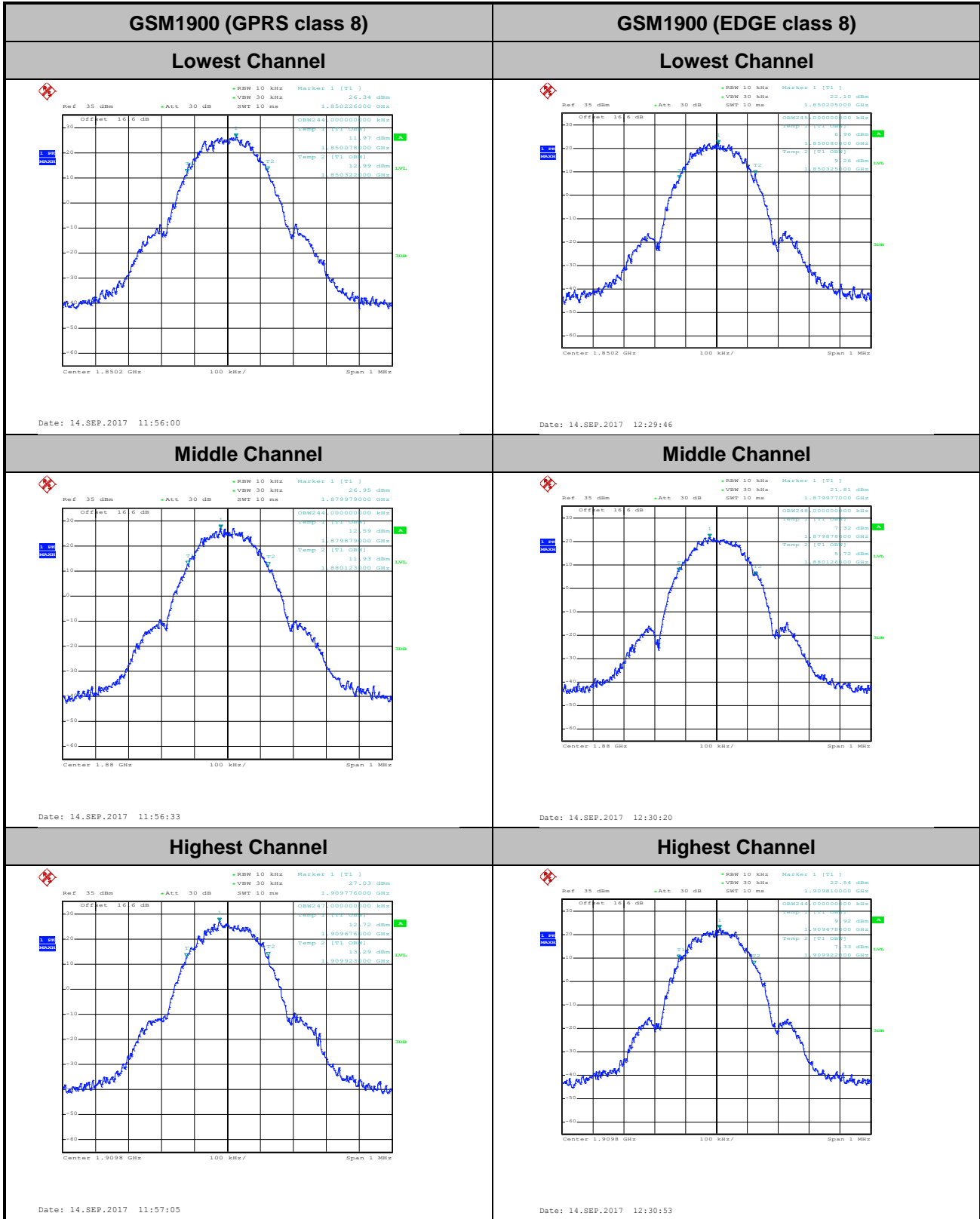



Conducted Band Edge



GSM

Lowest Band Edge

Highest Band Edge

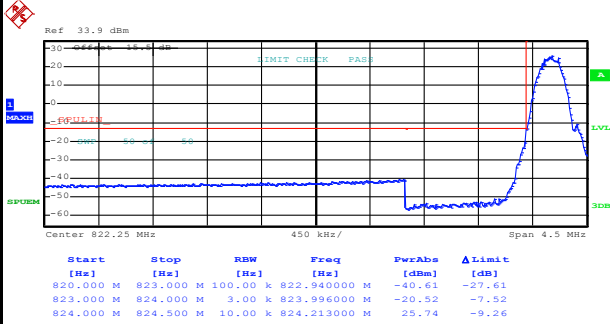

Date: 18.SEP.2017 14:50:28

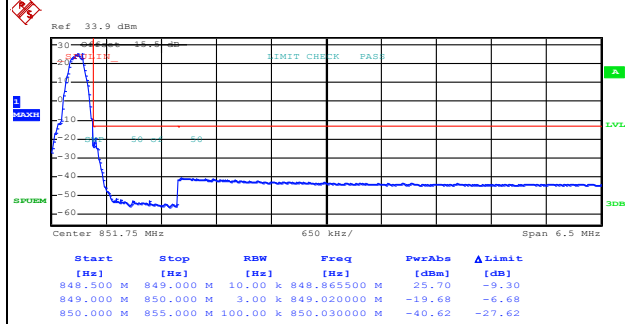

Date: 18.SEP.2017 14:52:02

GSM850 (EDGE class 8)

Lowest Band Edge

Highest Band Edge

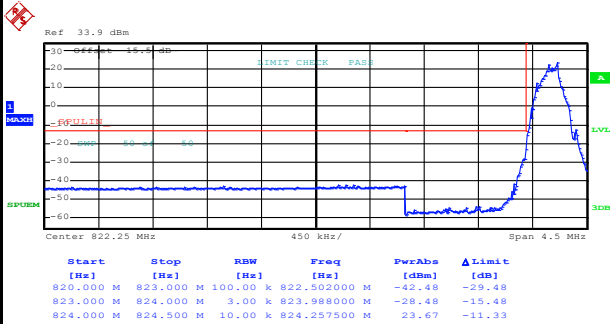

Date: 14.SEP.2017 11:45:59

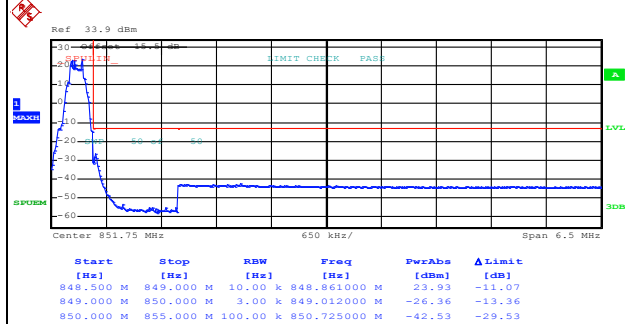

Date: 14.SEP.2017 11:47:33



GSM1900 (GPRS class 8)

Lowest Band Edge

Highest Band Edge

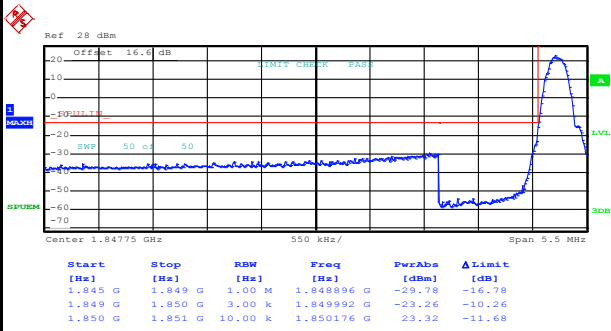

Date: 14.SEP.2017 11:58:38

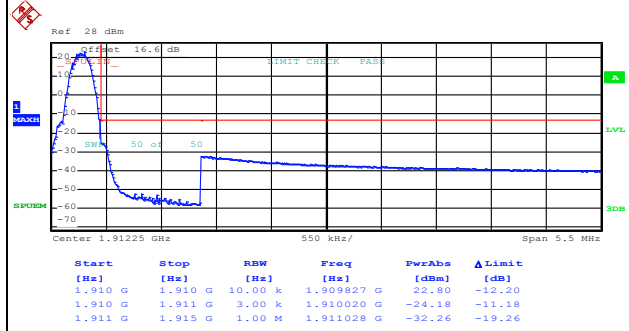

Date: 14.SEP.2017 12:00:12

GSM1900 (EDGE class 8)

Lowest Band Edge

Highest Band Edge

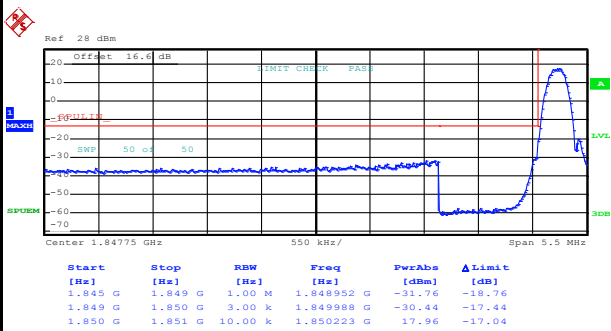

Date: 14.SEP.2017 12:32:28

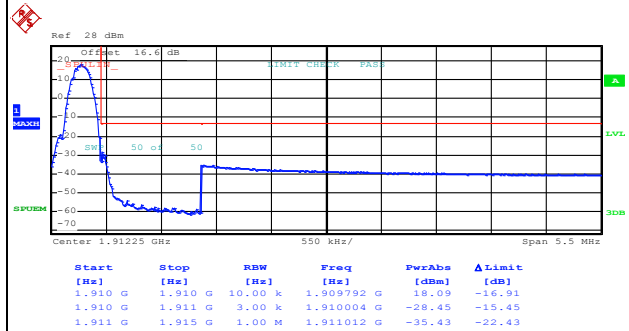

Date: 14.SEP.2017 12:34:03



Conducted Spurious Emission

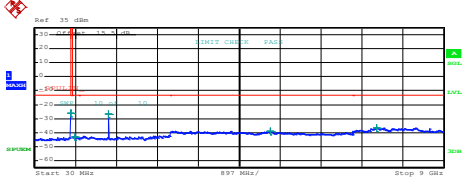
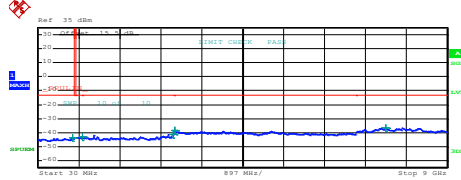
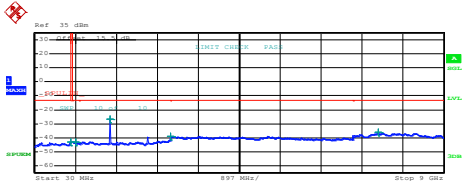
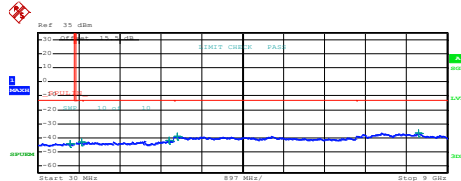
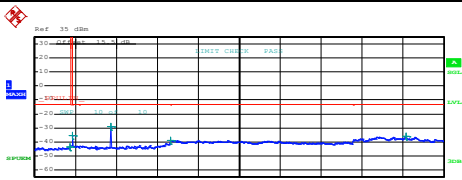
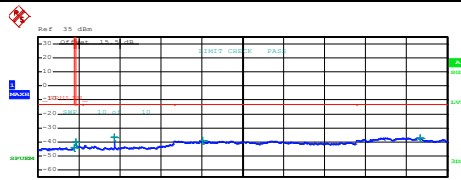

GSM	GSM850 (EDGE class 8)																																																																								
Lowest Channel	Lowest Channel																																																																								
 <table border="1" data-bbox="239 571 638 660"> <thead> <tr> <th>Start [Hz]</th> <th>Stop [Hz]</th> <th>RBW [Hz]</th> <th>Freq [Hz]</th> <th>PwrAve [dBm]</th> <th>ΔLimit [dB]</th> </tr> </thead> <tbody> <tr> <td>35,000 M</td> <td>825,000 M</td> <td>1,000 M</td> <td>810,000000 M</td> <td>-26.38</td> <td>-13.38</td> </tr> <tr> <td>855,000 M</td> <td>1,000 G</td> <td>1,000 M</td> <td>916,407504 M</td> <td>-43.24</td> <td>-30.24</td> </tr> <tr> <td>1,000 G</td> <td>3,000 G</td> <td>1,000 M</td> <td>1,1688000 G</td> <td>-20.50</td> <td>-23.50</td> </tr> <tr> <td>3,000 G</td> <td>7,000 G</td> <td>1,000 M</td> <td>5,130000 G</td> <td>-38.90</td> <td>-25.90</td> </tr> <tr> <td>7,000 G</td> <td>9,000 G</td> <td>1,000 M</td> <td>7,532000 G</td> <td>-36.37</td> <td>-23.37</td> </tr> </tbody> </table> <p>Date: 18.SEP.2017 14:53:57</p>	Start [Hz]	Stop [Hz]	RBW [Hz]	Freq [Hz]	PwrAve [dBm]	ΔLimit [dB]	35,000 M	825,000 M	1,000 M	810,000000 M	-26.38	-13.38	855,000 M	1,000 G	1,000 M	916,407504 M	-43.24	-30.24	1,000 G	3,000 G	1,000 M	1,1688000 G	-20.50	-23.50	3,000 G	7,000 G	1,000 M	5,130000 G	-38.90	-25.90	7,000 G	9,000 G	1,000 M	7,532000 G	-36.37	-23.37	 <table border="1" data-bbox="885 571 1284 660"> <thead> <tr> <th>Start [Hz]</th> <th>Stop [Hz]</th> <th>RBW [Hz]</th> <th>Freq [Hz]</th> <th>PwrAve [dBm]</th> <th>ΔLimit [dB]</th> </tr> </thead> <tbody> <tr> <td>35,000 M</td> <td>825,000 M</td> <td>1,000 M</td> <td>775,107500 M</td> <td>-43.39</td> <td>-30.39</td> </tr> <tr> <td>855,000 M</td> <td>1,000 G</td> <td>1,000 M</td> <td>997,353760 M</td> <td>-43.34</td> <td>-30.34</td> </tr> <tr> <td>1,000 G</td> <td>3,000 G</td> <td>1,000 M</td> <td>2,9994000 G</td> <td>-41.34</td> <td>-28.34</td> </tr> <tr> <td>3,000 G</td> <td>7,000 G</td> <td>1,000 M</td> <td>3,020000 G</td> <td>-38.45</td> <td>-25.45</td> </tr> <tr> <td>7,000 G</td> <td>9,000 G</td> <td>1,000 M</td> <td>7,648000 G</td> <td>-36.45</td> <td>-23.45</td> </tr> </tbody> </table> <p>Date: 14.SEP.2017 11:42:27</p>	Start [Hz]	Stop [Hz]	RBW [Hz]	Freq [Hz]	PwrAve [dBm]	ΔLimit [dB]	35,000 M	825,000 M	1,000 M	775,107500 M	-43.39	-30.39	855,000 M	1,000 G	1,000 M	997,353760 M	-43.34	-30.34	1,000 G	3,000 G	1,000 M	2,9994000 G	-41.34	-28.34	3,000 G	7,000 G	1,000 M	3,020000 G	-38.45	-25.45	7,000 G	9,000 G	1,000 M	7,648000 G	-36.45	-23.45
Start [Hz]	Stop [Hz]	RBW [Hz]	Freq [Hz]	PwrAve [dBm]	ΔLimit [dB]																																																																				
35,000 M	825,000 M	1,000 M	810,000000 M	-26.38	-13.38																																																																				
855,000 M	1,000 G	1,000 M	916,407504 M	-43.24	-30.24																																																																				
1,000 G	3,000 G	1,000 M	1,1688000 G	-20.50	-23.50																																																																				
3,000 G	7,000 G	1,000 M	5,130000 G	-38.90	-25.90																																																																				
7,000 G	9,000 G	1,000 M	7,532000 G	-36.37	-23.37																																																																				
Start [Hz]	Stop [Hz]	RBW [Hz]	Freq [Hz]	PwrAve [dBm]	ΔLimit [dB]																																																																				
35,000 M	825,000 M	1,000 M	775,107500 M	-43.39	-30.39																																																																				
855,000 M	1,000 G	1,000 M	997,353760 M	-43.34	-30.34																																																																				
1,000 G	3,000 G	1,000 M	2,9994000 G	-41.34	-28.34																																																																				
3,000 G	7,000 G	1,000 M	3,020000 G	-38.45	-25.45																																																																				
7,000 G	9,000 G	1,000 M	7,648000 G	-36.45	-23.45																																																																				
Middle Channel	Middle Channel																																																																								
 <table border="1" data-bbox="239 1086 638 1176"> <thead> <tr> <th>Start [Hz]</th> <th>Stop [Hz]</th> <th>RBW [Hz]</th> <th>Freq [Hz]</th> <th>PwrAve [dBm]</th> <th>ΔLimit [dB]</th> </tr> </thead> <tbody> <tr> <td>35,000 M</td> <td>825,000 M</td> <td>1,000 M</td> <td>812,495000 M</td> <td>-43.26</td> <td>-30.26</td> </tr> <tr> <td>855,000 M</td> <td>1,000 G</td> <td>1,000 M</td> <td>931,260000 M</td> <td>-43.18</td> <td>-30.18</td> </tr> <tr> <td>1,000 G</td> <td>3,000 G</td> <td>1,000 M</td> <td>1,672500 G</td> <td>-26.88</td> <td>-13.88</td> </tr> <tr> <td>3,000 G</td> <td>7,000 G</td> <td>1,000 M</td> <td>3,016000 G</td> <td>-39.16</td> <td>-26.16</td> </tr> <tr> <td>7,000 G</td> <td>9,000 G</td> <td>1,000 M</td> <td>7,357500 G</td> <td>-36.04</td> <td>-23.04</td> </tr> </tbody> </table> <p>Date: 18.SEP.2017 14:54:59</p>	Start [Hz]	Stop [Hz]	RBW [Hz]	Freq [Hz]	PwrAve [dBm]	ΔLimit [dB]	35,000 M	825,000 M	1,000 M	812,495000 M	-43.26	-30.26	855,000 M	1,000 G	1,000 M	931,260000 M	-43.18	-30.18	1,000 G	3,000 G	1,000 M	1,672500 G	-26.88	-13.88	3,000 G	7,000 G	1,000 M	3,016000 G	-39.16	-26.16	7,000 G	9,000 G	1,000 M	7,357500 G	-36.04	-23.04	 <table border="1" data-bbox="885 1086 1284 1176"> <thead> <tr> <th>Start [Hz]</th> <th>Stop [Hz]</th> <th>RBW [Hz]</th> <th>Freq [Hz]</th> <th>PwrAve [dBm]</th> <th>ΔLimit [dB]</th> </tr> </thead> <tbody> <tr> <td>35,000 M</td> <td>825,000 M</td> <td>1,000 M</td> <td>732,507500 M</td> <td>-44.06</td> <td>-31.06</td> </tr> <tr> <td>855,000 M</td> <td>1,000 G</td> <td>1,000 M</td> <td>888,130000 M</td> <td>-43.34</td> <td>-30.34</td> </tr> <tr> <td>1,000 G</td> <td>3,000 G</td> <td>1,000 M</td> <td>2,897000 G</td> <td>-42.08</td> <td>-29.08</td> </tr> <tr> <td>3,000 G</td> <td>7,000 G</td> <td>1,000 M</td> <td>3,098000 G</td> <td>-39.15</td> <td>-26.15</td> </tr> <tr> <td>7,000 G</td> <td>9,000 G</td> <td>1,000 M</td> <td>8,364500 G</td> <td>-36.60</td> <td>-23.60</td> </tr> </tbody> </table> <p>Date: 14.SEP.2017 11:43:19</p>	Start [Hz]	Stop [Hz]	RBW [Hz]	Freq [Hz]	PwrAve [dBm]	ΔLimit [dB]	35,000 M	825,000 M	1,000 M	732,507500 M	-44.06	-31.06	855,000 M	1,000 G	1,000 M	888,130000 M	-43.34	-30.34	1,000 G	3,000 G	1,000 M	2,897000 G	-42.08	-29.08	3,000 G	7,000 G	1,000 M	3,098000 G	-39.15	-26.15	7,000 G	9,000 G	1,000 M	8,364500 G	-36.60	-23.60
Start [Hz]	Stop [Hz]	RBW [Hz]	Freq [Hz]	PwrAve [dBm]	ΔLimit [dB]																																																																				
35,000 M	825,000 M	1,000 M	812,495000 M	-43.26	-30.26																																																																				
855,000 M	1,000 G	1,000 M	931,260000 M	-43.18	-30.18																																																																				
1,000 G	3,000 G	1,000 M	1,672500 G	-26.88	-13.88																																																																				
3,000 G	7,000 G	1,000 M	3,016000 G	-39.16	-26.16																																																																				
7,000 G	9,000 G	1,000 M	7,357500 G	-36.04	-23.04																																																																				
Start [Hz]	Stop [Hz]	RBW [Hz]	Freq [Hz]	PwrAve [dBm]	ΔLimit [dB]																																																																				
35,000 M	825,000 M	1,000 M	732,507500 M	-44.06	-31.06																																																																				
855,000 M	1,000 G	1,000 M	888,130000 M	-43.34	-30.34																																																																				
1,000 G	3,000 G	1,000 M	2,897000 G	-42.08	-29.08																																																																				
3,000 G	7,000 G	1,000 M	3,098000 G	-39.15	-26.15																																																																				
7,000 G	9,000 G	1,000 M	8,364500 G	-36.60	-23.60																																																																				
Highest Channel	Highest Channel																																																																								
 <table border="1" data-bbox="239 1601 638 1691"> <thead> <tr> <th>Start [Hz]</th> <th>Stop [Hz]</th> <th>RBW [Hz]</th> <th>Freq [Hz]</th> <th>PwrAve [dBm]</th> <th>ΔLimit [dB]</th> </tr> </thead> <tbody> <tr> <td>35,000 M</td> <td>825,000 M</td> <td>1,000 M</td> <td>804,030000 M</td> <td>-43.70</td> <td>-30.70</td> </tr> <tr> <td>855,000 M</td> <td>1,000 G</td> <td>1,000 M</td> <td>850,036250 M</td> <td>-35.49</td> <td>-22.49</td> </tr> <tr> <td>1,000 G</td> <td>3,000 G</td> <td>1,000 M</td> <td>1,697500 G</td> <td>-39.01</td> <td>-26.01</td> </tr> <tr> <td>3,000 G</td> <td>7,000 G</td> <td>1,000 M</td> <td>3,017000 G</td> <td>-38.90</td> <td>-25.90</td> </tr> <tr> <td>7,000 G</td> <td>9,000 G</td> <td>1,000 M</td> <td>8,181500 G</td> <td>-36.24</td> <td>-23.24</td> </tr> </tbody> </table> <p>Date: 18.SEP.2017 14:55:51</p>	Start [Hz]	Stop [Hz]	RBW [Hz]	Freq [Hz]	PwrAve [dBm]	ΔLimit [dB]	35,000 M	825,000 M	1,000 M	804,030000 M	-43.70	-30.70	855,000 M	1,000 G	1,000 M	850,036250 M	-35.49	-22.49	1,000 G	3,000 G	1,000 M	1,697500 G	-39.01	-26.01	3,000 G	7,000 G	1,000 M	3,017000 G	-38.90	-25.90	7,000 G	9,000 G	1,000 M	8,181500 G	-36.24	-23.24	 <table border="1" data-bbox="885 1601 1284 1691"> <thead> <tr> <th>Start [Hz]</th> <th>Stop [Hz]</th> <th>RBW [Hz]</th> <th>Freq [Hz]</th> <th>PwrAve [dBm]</th> <th>ΔLimit [dB]</th> </tr> </thead> <tbody> <tr> <td>35,000 M</td> <td>825,000 M</td> <td>1,000 M</td> <td>814,217500 M</td> <td>-43.19</td> <td>-30.19</td> </tr> <tr> <td>855,000 M</td> <td>1,000 G</td> <td>1,000 M</td> <td>855,036250 M</td> <td>-40.18</td> <td>-27.18</td> </tr> <tr> <td>1,000 G</td> <td>3,000 G</td> <td>1,000 M</td> <td>1,698000 G</td> <td>-36.08</td> <td>-23.08</td> </tr> <tr> <td>3,000 G</td> <td>7,000 G</td> <td>1,000 M</td> <td>3,627000 G</td> <td>-38.76</td> <td>-25.76</td> </tr> <tr> <td>7,000 G</td> <td>9,000 G</td> <td>1,000 M</td> <td>8,410000 G</td> <td>-37.02</td> <td>-24.02</td> </tr> </tbody> </table> <p>Date: 14.SEP.2017 11:44:20</p>	Start [Hz]	Stop [Hz]	RBW [Hz]	Freq [Hz]	PwrAve [dBm]	ΔLimit [dB]	35,000 M	825,000 M	1,000 M	814,217500 M	-43.19	-30.19	855,000 M	1,000 G	1,000 M	855,036250 M	-40.18	-27.18	1,000 G	3,000 G	1,000 M	1,698000 G	-36.08	-23.08	3,000 G	7,000 G	1,000 M	3,627000 G	-38.76	-25.76	7,000 G	9,000 G	1,000 M	8,410000 G	-37.02	-24.02
Start [Hz]	Stop [Hz]	RBW [Hz]	Freq [Hz]	PwrAve [dBm]	ΔLimit [dB]																																																																				
35,000 M	825,000 M	1,000 M	804,030000 M	-43.70	-30.70																																																																				
855,000 M	1,000 G	1,000 M	850,036250 M	-35.49	-22.49																																																																				
1,000 G	3,000 G	1,000 M	1,697500 G	-39.01	-26.01																																																																				
3,000 G	7,000 G	1,000 M	3,017000 G	-38.90	-25.90																																																																				
7,000 G	9,000 G	1,000 M	8,181500 G	-36.24	-23.24																																																																				
Start [Hz]	Stop [Hz]	RBW [Hz]	Freq [Hz]	PwrAve [dBm]	ΔLimit [dB]																																																																				
35,000 M	825,000 M	1,000 M	814,217500 M	-43.19	-30.19																																																																				
855,000 M	1,000 G	1,000 M	855,036250 M	-40.18	-27.18																																																																				
1,000 G	3,000 G	1,000 M	1,698000 G	-36.08	-23.08																																																																				
3,000 G	7,000 G	1,000 M	3,627000 G	-38.76	-25.76																																																																				
7,000 G	9,000 G	1,000 M	8,410000 G	-37.02	-24.02																																																																				

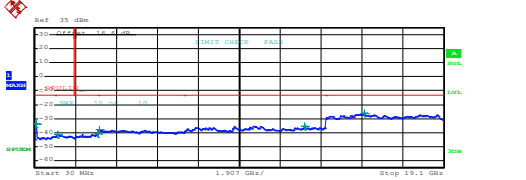
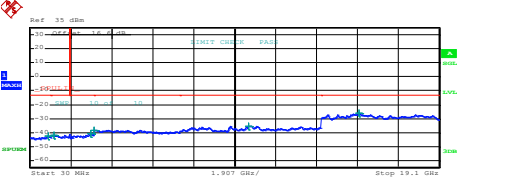
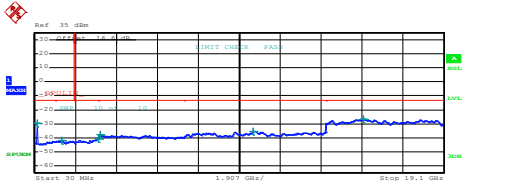
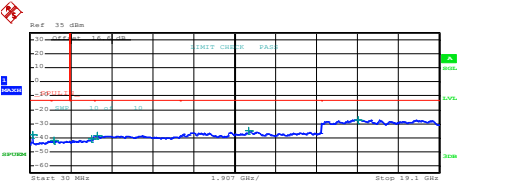
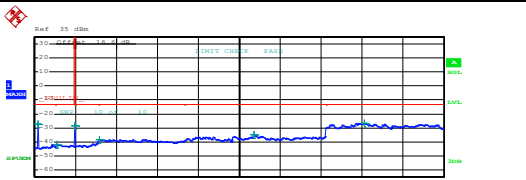
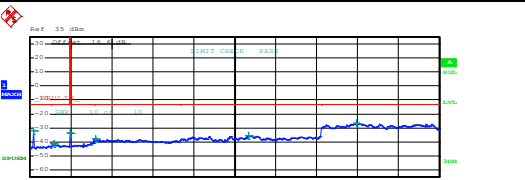

GSM1900 (GPRS class 8)	GSM1900 (EDGE class 8)																																																																																				
Lowest Channel	Lowest Channel																																																																																				
 <table border="1" data-bbox="239 571 702 672"> <thead> <tr> <th>Start [MHz]</th> <th>Stop [MHz]</th> <th>RBW [Hz]</th> <th>Freq [Hz]</th> <th>PwrAve [dBm]</th> <th>ΔLimit [dB]</th> </tr> </thead> <tbody> <tr><td>30.0000</td><td>1.0000</td><td>1.000</td><td>111.965000</td><td>-33.65</td><td>-29.53</td></tr> <tr><td>1.0000</td><td>1.8450</td><td>1.000</td><td>1.095696</td><td>-41.06</td><td>-26.06</td></tr> <tr><td>1.8450</td><td>3.0000</td><td>1.000</td><td>2.978959</td><td>-40.53</td><td>-27.53</td></tr> <tr><td>3.0000</td><td>7.0000</td><td>1.000</td><td>3.033000</td><td>-38.07</td><td>-25.07</td></tr> <tr><td>7.0000</td><td>13.6000</td><td>1.000</td><td>12.604225</td><td>-35.26</td><td>-22.26</td></tr> <tr><td>13.6000</td><td>19.1000</td><td>1.000</td><td>15.392312</td><td>-26.26</td><td>-13.26</td></tr> </tbody> </table> <p>Date: 14.SEP.2017 12:01:09</p>	Start [MHz]	Stop [MHz]	RBW [Hz]	Freq [Hz]	PwrAve [dBm]	ΔLimit [dB]	30.0000	1.0000	1.000	111.965000	-33.65	-29.53	1.0000	1.8450	1.000	1.095696	-41.06	-26.06	1.8450	3.0000	1.000	2.978959	-40.53	-27.53	3.0000	7.0000	1.000	3.033000	-38.07	-25.07	7.0000	13.6000	1.000	12.604225	-35.26	-22.26	13.6000	19.1000	1.000	15.392312	-26.26	-13.26	 <table border="1" data-bbox="893 571 1356 672"> <thead> <tr> <th>Start [MHz]</th> <th>Stop [MHz]</th> <th>RBW [Hz]</th> <th>Freq [Hz]</th> <th>PwrAve [dBm]</th> <th>ΔLimit [dB]</th> </tr> </thead> <tbody> <tr><td>30.0000</td><td>1.0000</td><td>1.000</td><td>862.240000</td><td>-42.66</td><td>-29.66</td></tr> <tr><td>1.0000</td><td>1.8450</td><td>1.000</td><td>1.132243</td><td>-41.89</td><td>-28.89</td></tr> <tr><td>1.8450</td><td>3.0000</td><td>1.000</td><td>2.880306</td><td>-40.60</td><td>-27.60</td></tr> <tr><td>3.0000</td><td>7.0000</td><td>1.000</td><td>3.012000</td><td>-38.23</td><td>-25.23</td></tr> <tr><td>7.0000</td><td>13.6000</td><td>1.000</td><td>10.210075</td><td>-35.40</td><td>-22.40</td></tr> <tr><td>13.6000</td><td>19.1000</td><td>1.000</td><td>15.362063</td><td>-26.34</td><td>-13.34</td></tr> </tbody> </table> <p>Date: 14.SEP.2017 12:35:02</p>	Start [MHz]	Stop [MHz]	RBW [Hz]	Freq [Hz]	PwrAve [dBm]	ΔLimit [dB]	30.0000	1.0000	1.000	862.240000	-42.66	-29.66	1.0000	1.8450	1.000	1.132243	-41.89	-28.89	1.8450	3.0000	1.000	2.880306	-40.60	-27.60	3.0000	7.0000	1.000	3.012000	-38.23	-25.23	7.0000	13.6000	1.000	10.210075	-35.40	-22.40	13.6000	19.1000	1.000	15.362063	-26.34	-13.34
Start [MHz]	Stop [MHz]	RBW [Hz]	Freq [Hz]	PwrAve [dBm]	ΔLimit [dB]																																																																																
30.0000	1.0000	1.000	111.965000	-33.65	-29.53																																																																																
1.0000	1.8450	1.000	1.095696	-41.06	-26.06																																																																																
1.8450	3.0000	1.000	2.978959	-40.53	-27.53																																																																																
3.0000	7.0000	1.000	3.033000	-38.07	-25.07																																																																																
7.0000	13.6000	1.000	12.604225	-35.26	-22.26																																																																																
13.6000	19.1000	1.000	15.392312	-26.26	-13.26																																																																																
Start [MHz]	Stop [MHz]	RBW [Hz]	Freq [Hz]	PwrAve [dBm]	ΔLimit [dB]																																																																																
30.0000	1.0000	1.000	862.240000	-42.66	-29.66																																																																																
1.0000	1.8450	1.000	1.132243	-41.89	-28.89																																																																																
1.8450	3.0000	1.000	2.880306	-40.60	-27.60																																																																																
3.0000	7.0000	1.000	3.012000	-38.23	-25.23																																																																																
7.0000	13.6000	1.000	10.210075	-35.40	-22.40																																																																																
13.6000	19.1000	1.000	15.362063	-26.34	-13.34																																																																																
Middle Channel	Middle Channel																																																																																				
 <table border="1" data-bbox="239 1086 702 1187"> <thead> <tr> <th>Start [MHz]</th> <th>Stop [MHz]</th> <th>RBW [Hz]</th> <th>Freq [Hz]</th> <th>PwrAve [dBm]</th> <th>ΔLimit [dB]</th> </tr> </thead> <tbody> <tr><td>30.0000</td><td>1.0000</td><td>1.000</td><td>141.792500</td><td>-29.75</td><td>-16.75</td></tr> <tr><td>1.0000</td><td>1.8450</td><td>1.000</td><td>1.280761</td><td>-41.95</td><td>-28.95</td></tr> <tr><td>1.8450</td><td>3.0000</td><td>1.000</td><td>2.989964</td><td>-40.68</td><td>-27.68</td></tr> <tr><td>3.0000</td><td>7.0000</td><td>1.000</td><td>3.078000</td><td>-38.09</td><td>-25.09</td></tr> <tr><td>7.0000</td><td>13.6000</td><td>1.000</td><td>10.231525</td><td>-35.28</td><td>-22.28</td></tr> <tr><td>13.6000</td><td>19.1000</td><td>1.000</td><td>15.355188</td><td>-26.66</td><td>-13.66</td></tr> </tbody> </table> <p>Date: 14.SEP.2017 12:01:59</p>	Start [MHz]	Stop [MHz]	RBW [Hz]	Freq [Hz]	PwrAve [dBm]	ΔLimit [dB]	30.0000	1.0000	1.000	141.792500	-29.75	-16.75	1.0000	1.8450	1.000	1.280761	-41.95	-28.95	1.8450	3.0000	1.000	2.989964	-40.68	-27.68	3.0000	7.0000	1.000	3.078000	-38.09	-25.09	7.0000	13.6000	1.000	10.231525	-35.28	-22.28	13.6000	19.1000	1.000	15.355188	-26.66	-13.66	 <table border="1" data-bbox="893 1086 1356 1187"> <thead> <tr> <th>Start [MHz]</th> <th>Stop [MHz]</th> <th>RBW [Hz]</th> <th>Freq [Hz]</th> <th>PwrAve [dBm]</th> <th>ΔLimit [dB]</th> </tr> </thead> <tbody> <tr><td>30.0000</td><td>1.0000</td><td>1.000</td><td>141.792500</td><td>-37.52</td><td>-24.52</td></tr> <tr><td>1.0000</td><td>1.8450</td><td>1.000</td><td>1.132876</td><td>-42.37</td><td>-29.37</td></tr> <tr><td>1.8450</td><td>3.0000</td><td>1.000</td><td>2.886617</td><td>-40.70</td><td>-27.70</td></tr> <tr><td>3.0000</td><td>7.0000</td><td>1.000</td><td>3.154000</td><td>-38.22</td><td>-25.22</td></tr> <tr><td>7.0000</td><td>13.6000</td><td>1.000</td><td>10.231725</td><td>-35.90</td><td>-22.90</td></tr> <tr><td>13.6000</td><td>19.1000</td><td>1.000</td><td>15.307083</td><td>-27.04</td><td>-14.04</td></tr> </tbody> </table> <p>Date: 14.SEP.2017 12:35:52</p>	Start [MHz]	Stop [MHz]	RBW [Hz]	Freq [Hz]	PwrAve [dBm]	ΔLimit [dB]	30.0000	1.0000	1.000	141.792500	-37.52	-24.52	1.0000	1.8450	1.000	1.132876	-42.37	-29.37	1.8450	3.0000	1.000	2.886617	-40.70	-27.70	3.0000	7.0000	1.000	3.154000	-38.22	-25.22	7.0000	13.6000	1.000	10.231725	-35.90	-22.90	13.6000	19.1000	1.000	15.307083	-27.04	-14.04
Start [MHz]	Stop [MHz]	RBW [Hz]	Freq [Hz]	PwrAve [dBm]	ΔLimit [dB]																																																																																
30.0000	1.0000	1.000	141.792500	-29.75	-16.75																																																																																
1.0000	1.8450	1.000	1.280761	-41.95	-28.95																																																																																
1.8450	3.0000	1.000	2.989964	-40.68	-27.68																																																																																
3.0000	7.0000	1.000	3.078000	-38.09	-25.09																																																																																
7.0000	13.6000	1.000	10.231525	-35.28	-22.28																																																																																
13.6000	19.1000	1.000	15.355188	-26.66	-13.66																																																																																
Start [MHz]	Stop [MHz]	RBW [Hz]	Freq [Hz]	PwrAve [dBm]	ΔLimit [dB]																																																																																
30.0000	1.0000	1.000	141.792500	-37.52	-24.52																																																																																
1.0000	1.8450	1.000	1.132876	-42.37	-29.37																																																																																
1.8450	3.0000	1.000	2.886617	-40.70	-27.70																																																																																
3.0000	7.0000	1.000	3.154000	-38.22	-25.22																																																																																
7.0000	13.6000	1.000	10.231725	-35.90	-22.90																																																																																
13.6000	19.1000	1.000	15.307083	-27.04	-14.04																																																																																
Highest Channel	Highest Channel																																																																																				
 <table border="1" data-bbox="239 1601 702 1702"> <thead> <tr> <th>Start [MHz]</th> <th>Stop [MHz]</th> <th>RBW [Hz]</th> <th>Freq [Hz]</th> <th>PwrAve [dBm]</th> <th>ΔLimit [dB]</th> </tr> </thead> <tbody> <tr><td>30.0000</td><td>1.0000</td><td>1.000</td><td>171.600000</td><td>-27.25</td><td>-14.25</td></tr> <tr><td>1.0000</td><td>1.8450</td><td>1.000</td><td>1.072459</td><td>-41.70</td><td>-28.70</td></tr> <tr><td>1.8450</td><td>3.0000</td><td>1.000</td><td>1.932071</td><td>-38.42</td><td>-25.42</td></tr> <tr><td>3.0000</td><td>7.0000</td><td>1.000</td><td>3.027000</td><td>-38.24</td><td>-25.24</td></tr> <tr><td>7.0000</td><td>13.6000</td><td>1.000</td><td>10.236475</td><td>-34.76</td><td>-21.76</td></tr> <tr><td>13.6000</td><td>19.1000</td><td>1.000</td><td>15.406063</td><td>-26.34</td><td>-13.34</td></tr> </tbody> </table> <p>Date: 14.SEP.2017 12:02:49</p>	Start [MHz]	Stop [MHz]	RBW [Hz]	Freq [Hz]	PwrAve [dBm]	ΔLimit [dB]	30.0000	1.0000	1.000	171.600000	-27.25	-14.25	1.0000	1.8450	1.000	1.072459	-41.70	-28.70	1.8450	3.0000	1.000	1.932071	-38.42	-25.42	3.0000	7.0000	1.000	3.027000	-38.24	-25.24	7.0000	13.6000	1.000	10.236475	-34.76	-21.76	13.6000	19.1000	1.000	15.406063	-26.34	-13.34	 <table border="1" data-bbox="893 1601 1356 1702"> <thead> <tr> <th>Start [MHz]</th> <th>Stop [MHz]</th> <th>RBW [Hz]</th> <th>Freq [Hz]</th> <th>PwrAve [dBm]</th> <th>ΔLimit [dB]</th> </tr> </thead> <tbody> <tr><td>30.0000</td><td>1.0000</td><td>1.000</td><td>171.375000</td><td>-31.94</td><td>-18.94</td></tr> <tr><td>1.0000</td><td>1.8450</td><td>1.000</td><td>1.128651</td><td>-41.47</td><td>-28.47</td></tr> <tr><td>1.8450</td><td>3.0000</td><td>1.000</td><td>1.932071</td><td>-39.76</td><td>-26.76</td></tr> <tr><td>3.0000</td><td>7.0000</td><td>1.000</td><td>3.049000</td><td>-37.62</td><td>-24.62</td></tr> <tr><td>7.0000</td><td>13.6000</td><td>1.000</td><td>10.209250</td><td>-35.23</td><td>-22.23</td></tr> <tr><td>13.6000</td><td>19.1000</td><td>1.000</td><td>15.244500</td><td>-26.61</td><td>-13.61</td></tr> </tbody> </table> <p>Date: 14.SEP.2017 12:36:41</p>	Start [MHz]	Stop [MHz]	RBW [Hz]	Freq [Hz]	PwrAve [dBm]	ΔLimit [dB]	30.0000	1.0000	1.000	171.375000	-31.94	-18.94	1.0000	1.8450	1.000	1.128651	-41.47	-28.47	1.8450	3.0000	1.000	1.932071	-39.76	-26.76	3.0000	7.0000	1.000	3.049000	-37.62	-24.62	7.0000	13.6000	1.000	10.209250	-35.23	-22.23	13.6000	19.1000	1.000	15.244500	-26.61	-13.61
Start [MHz]	Stop [MHz]	RBW [Hz]	Freq [Hz]	PwrAve [dBm]	ΔLimit [dB]																																																																																
30.0000	1.0000	1.000	171.600000	-27.25	-14.25																																																																																
1.0000	1.8450	1.000	1.072459	-41.70	-28.70																																																																																
1.8450	3.0000	1.000	1.932071	-38.42	-25.42																																																																																
3.0000	7.0000	1.000	3.027000	-38.24	-25.24																																																																																
7.0000	13.6000	1.000	10.236475	-34.76	-21.76																																																																																
13.6000	19.1000	1.000	15.406063	-26.34	-13.34																																																																																
Start [MHz]	Stop [MHz]	RBW [Hz]	Freq [Hz]	PwrAve [dBm]	ΔLimit [dB]																																																																																
30.0000	1.0000	1.000	171.375000	-31.94	-18.94																																																																																
1.0000	1.8450	1.000	1.128651	-41.47	-28.47																																																																																
1.8450	3.0000	1.000	1.932071	-39.76	-26.76																																																																																
3.0000	7.0000	1.000	3.049000	-37.62	-24.62																																																																																
7.0000	13.6000	1.000	10.209250	-35.23	-22.23																																																																																
13.6000	19.1000	1.000	15.244500	-26.61	-13.61																																																																																



Frequency Stability

Test Conditions	Middle Channel	GSM850 (GSM)	GSM850 (EDGE class 8)	Limit 2.5ppm
Temperature (°C)	Voltage (Volt)	Deviation (ppm)		Result
50	Normal Voltage	0.0084	0.0048	PASS
40	Normal Voltage	0.0048	0.0036	
30	Normal Voltage	0.0084	0.0084	
20(Ref.)	Normal Voltage	0.0000	0.0000	
10	Normal Voltage	0.0072	0.0120	
0	Normal Voltage	0.0108	0.0096	
-10	Normal Voltage	0.0060	0.0048	
-20	Normal Voltage	0.0108	0.0143	
-30	Normal Voltage	0.0072	0.0096	
20	Maximum Voltage	0.0048	0.0072	
20	Normal Voltage	0.0000	0.0000	
20	Battery End Point	0.0012	0.0024	

Test Conditions	Middle Channel	GSM1900 (GPRS class 8)	GSM1900 (EDGE class 8)	Limit Note 2.
Temperature (°C)	Voltage (Volt)	Deviation (ppm)		Result
50	Normal Voltage	0.0011	0.0000	PASS
40	Normal Voltage	0.0016	0.0032	
30	Normal Voltage	0.0005	0.0005	
20(Ref.)	Normal Voltage	0.0000	0.0000	
10	Normal Voltage	0.0005	0.0027	
0	Normal Voltage	0.0048	0.0043	
-10	Normal Voltage	0.0021	0.0037	
-20	Normal Voltage	0.0011	0.0053	
-30	Normal Voltage	0.0021	0.0059	
20	Maximum Voltage	0.0021	0.0021	
20	Normal Voltage	0.0000	0.0000	
20	Battery End Point	0.0011	0.0027	

Note:

1. Normal Voltage = 3.85V. ; Battery End Point (BEP) = 3.6 V. ; Maximum Voltage =4.2 V



2. The frequency fundamental emissions stay within the authorized frequency block based on the frequency deviation measured is small.



A2. WCDMA

Peak-to-Average Ratio

Mode	WCDMA Band V	WCDMA Band II	WCDMA Band IV	Limit: 13dB
Mod.	RMC 12.2Kbps	RMC 12.2Kbps	RMC 12.2Kbps	Result
Lowest CH	3.16	3.56	3.44	PASS
Middle CH	3.28	3.64	3.48	
Highest CH	3.16	3.44	3.40	

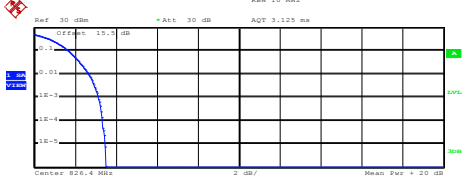
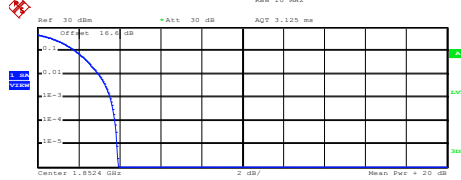
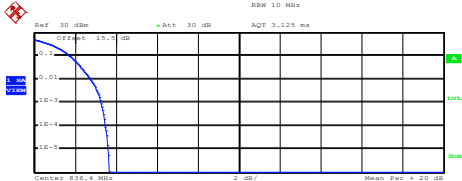
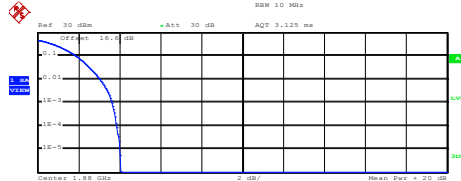
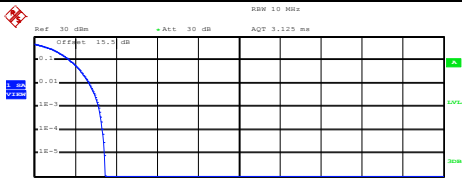
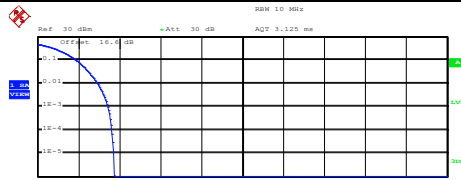

WCDMA Band V (RMC 12.2Kbps)	WCDMA Band II (RMC 12.2Kbps)																
<p style="text-align: center;">Lowest Channel</p>  <p>Center 826.4 MHz</p> <p>Complementary Cumulative Distribution Function (100000 samples) Trace 1 Mean 22.31 dBm Peak 25.81 dBm Crest 3.49 dB</p> <table border="1"> <tr><td>10 %</td><td>1.68 dB</td></tr> <tr><td>1 %</td><td>2.68 dB</td></tr> <tr><td>.1 %</td><td>3.16 dB</td></tr> <tr><td>.01 %</td><td>3.32 dB</td></tr> </table> <p>Date: 14.SEP.2017 14:13:13</p>	10 %	1.68 dB	1 %	2.68 dB	.1 %	3.16 dB	.01 %	3.32 dB	<p style="text-align: center;">Lowest Channel</p>  <p>Center 1.8524 GHz</p> <p>Complementary Cumulative Distribution Function (100000 samples) Trace 1 Mean 22.09 dBm Peak 26.02 dBm Crest 3.93 dB</p> <table border="1"> <tr><td>10 %</td><td>1.84 dB</td></tr> <tr><td>1 %</td><td>2.96 dB</td></tr> <tr><td>.1 %</td><td>3.56 dB</td></tr> <tr><td>.01 %</td><td>3.76 dB</td></tr> </table> <p>Date: 14.SEP.2017 13:47:12</p>	10 %	1.84 dB	1 %	2.96 dB	.1 %	3.56 dB	.01 %	3.76 dB
10 %	1.68 dB																
1 %	2.68 dB																
.1 %	3.16 dB																
.01 %	3.32 dB																
10 %	1.84 dB																
1 %	2.96 dB																
.1 %	3.56 dB																
.01 %	3.76 dB																
<p style="text-align: center;">Middle Channel</p>  <p>Center 830.4 MHz</p> <p>Complementary Cumulative Distribution Function (100000 samples) Trace 1 Mean 22.35 dBm Peak 26.02 dBm Crest 3.67 dB</p> <table border="1"> <tr><td>10 %</td><td>1.76 dB</td></tr> <tr><td>1 %</td><td>2.76 dB</td></tr> <tr><td>.1 %</td><td>3.28 dB</td></tr> <tr><td>.01 %</td><td>3.48 dB</td></tr> </table> <p>Date: 14.SEP.2017 14:13:24</p>	10 %	1.76 dB	1 %	2.76 dB	.1 %	3.28 dB	.01 %	3.48 dB	<p style="text-align: center;">Middle Channel</p>  <p>Center 1.88 GHz</p> <p>Complementary Cumulative Distribution Function (100000 samples) Trace 1 Mean 21.97 dBm Peak 26.02 dBm Crest 4.05 dB</p> <table border="1"> <tr><td>10 %</td><td>1.88 dB</td></tr> <tr><td>1 %</td><td>3.04 dB</td></tr> <tr><td>.1 %</td><td>3.64 dB</td></tr> <tr><td>.01 %</td><td>3.88 dB</td></tr> </table> <p>Date: 14.SEP.2017 13:47:20</p>	10 %	1.88 dB	1 %	3.04 dB	.1 %	3.64 dB	.01 %	3.88 dB
10 %	1.76 dB																
1 %	2.76 dB																
.1 %	3.28 dB																
.01 %	3.48 dB																
10 %	1.88 dB																
1 %	3.04 dB																
.1 %	3.64 dB																
.01 %	3.88 dB																
<p style="text-align: center;">Highest Channel</p>  <p>Center 846.6 MHz</p> <p>Complementary Cumulative Distribution Function (100000 samples) Trace 1 Mean 22.36 dBm Peak 25.81 dBm Crest 3.45 dB</p> <table border="1"> <tr><td>10 %</td><td>1.72 dB</td></tr> <tr><td>1 %</td><td>2.68 dB</td></tr> <tr><td>.1 %</td><td>3.16 dB</td></tr> <tr><td>.01 %</td><td>3.32 dB</td></tr> </table> <p>Date: 14.SEP.2017 14:13:34</p>	10 %	1.72 dB	1 %	2.68 dB	.1 %	3.16 dB	.01 %	3.32 dB	<p style="text-align: center;">Highest Channel</p>  <p>Center 1.9076 GHz</p> <p>Complementary Cumulative Distribution Function (100000 samples) Trace 1 Mean 21.91 dBm Peak 25.67 dBm Crest 3.75 dB</p> <table border="1"> <tr><td>10 %</td><td>1.88 dB</td></tr> <tr><td>1 %</td><td>2.92 dB</td></tr> <tr><td>.1 %</td><td>3.44 dB</td></tr> <tr><td>.01 %</td><td>3.64 dB</td></tr> </table> <p>Date: 14.SEP.2017 13:47:28</p>	10 %	1.88 dB	1 %	2.92 dB	.1 %	3.44 dB	.01 %	3.64 dB
10 %	1.72 dB																
1 %	2.68 dB																
.1 %	3.16 dB																
.01 %	3.32 dB																
10 %	1.88 dB																
1 %	2.92 dB																
.1 %	3.44 dB																
.01 %	3.64 dB																



WCDMA Band IV (RMC 12.2Kbps)

Lowest Channel

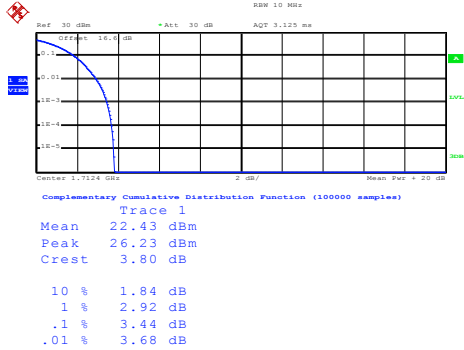

Middle Channel

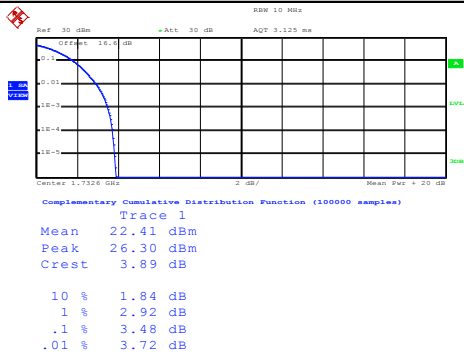

Highest Channel

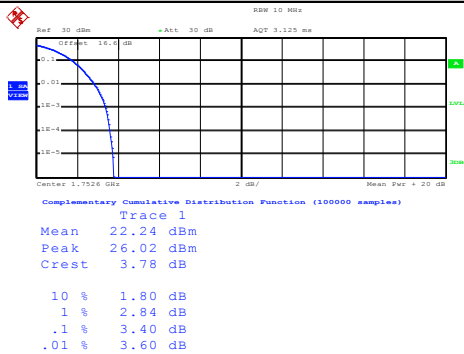



26dB Bandwidth

Mode	WCDMA Band V	WCDMA Band II	WCDMA Band IV
Mod.	RMC 12.2Kbps	RMC 12.2Kbps	RMC 12.2Kbps
Lowest CH	4.69	4.68	4.67
Middle CH	4.70	4.69	4.68
Highest CH	4.70	4.67	4.67



WCDMA Band V (RMC 12.2Kbps)	WCDMA Band II (RMC 12.2Kbps)
<p style="text-align: center;">Lowest Channel</p> <p>Date: 14.SEP.2017 14:02:13</p>	<p style="text-align: center;">Lowest Channel</p> <p>Date: 14.SEP.2017 13:36:19</p>
<p style="text-align: center;">Middle Channel</p> <p>Date: 14.SEP.2017 14:02:41</p>	<p style="text-align: center;">Middle Channel</p> <p>Date: 14.SEP.2017 13:36:47</p>
<p style="text-align: center;">Highest Channel</p> <p>Date: 14.SEP.2017 14:03:09</p>	<p style="text-align: center;">Highest Channel</p> <p>Date: 14.SEP.2017 13:37:15</p>



WCDMA Band IV (RMC 12.2Kbps)

Lowest Channel

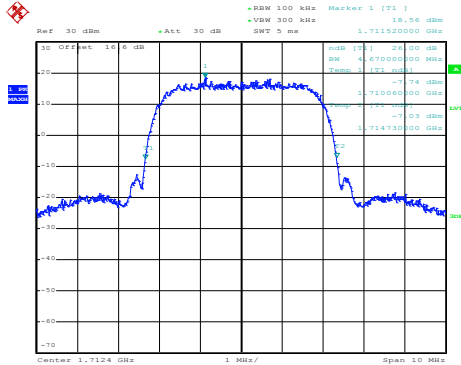

Date: 14.SEP.2017 13:48:58

Middle Channel

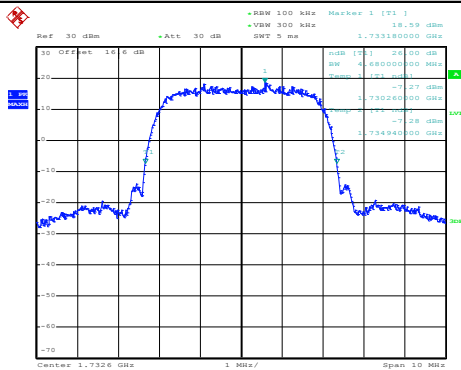

Date: 14.SEP.2017 13:49:26

Highest Channel

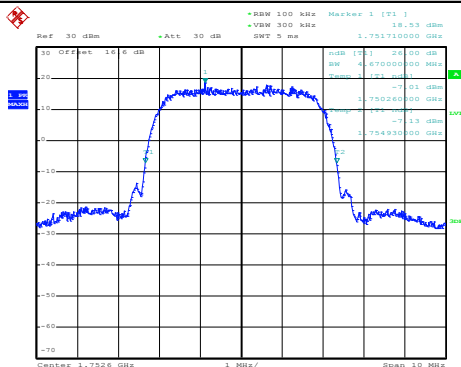

Date: 14.SEP.2017 13:49:53



Occupied Bandwidth

Mode	WCDMA Band V	WCDMA Band II	WCDMA Band IV
Mod.	RMC 12.2Kbps	RMC 12.2Kbps	RMC 12.2Kbps
Lowest CH	4.12	4.12	4.11
Middle CH	4.12	4.13	4.13
Highest CH	4.12	4.13	4.12



WCDMA Band V (RMC 12.2Kbps)

WCDMA Band II (RMC 12.2Kbps)

Lowest Channel

Lowest Channel

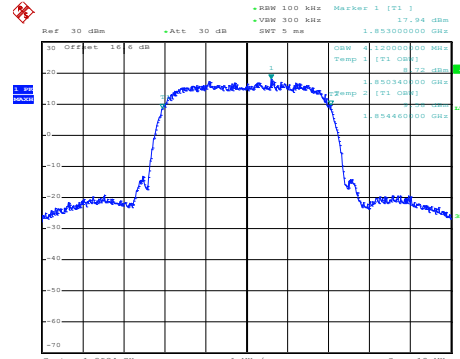
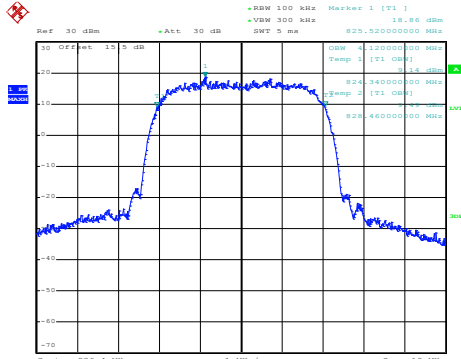

Date: 14.SEP.2017 14:03:48

Date: 14.SEP.2017 13:37:48

Middle Channel

Middle Channel

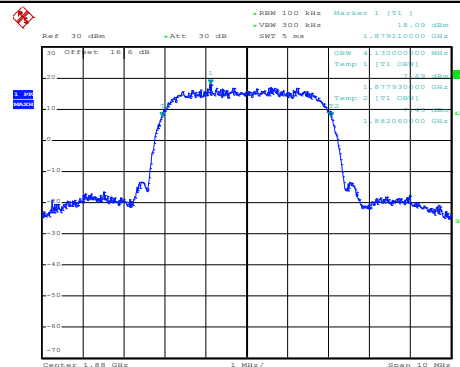
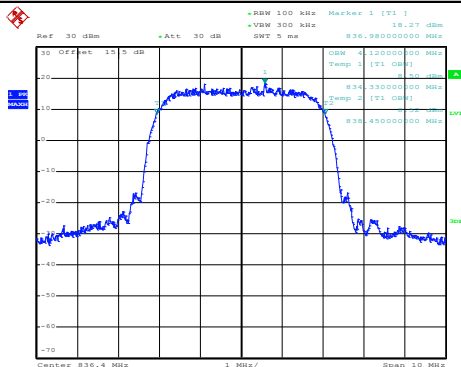

Date: 14.SEP.2017 14:04:15

Date: 14.SEP.2017 13:38:16

Highest Channel

Highest Channel

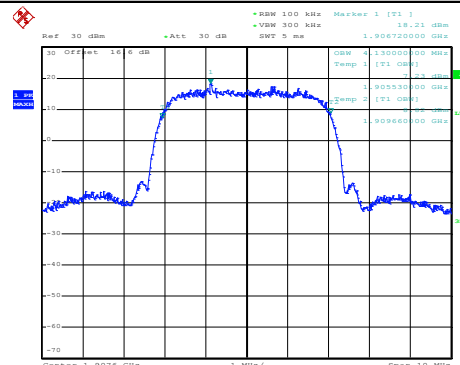
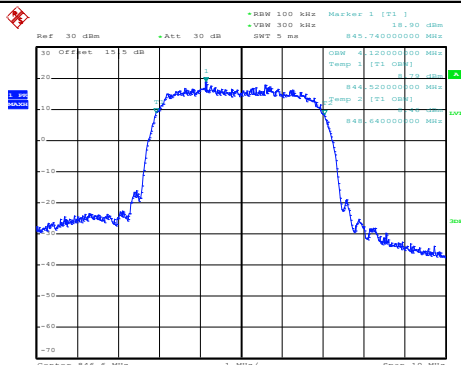

Date: 14.SEP.2017 14:04:43

Date: 14.SEP.2017 13:38:44



WCDMA Band IV (RMC 12.2Kbps)

Lowest Channel

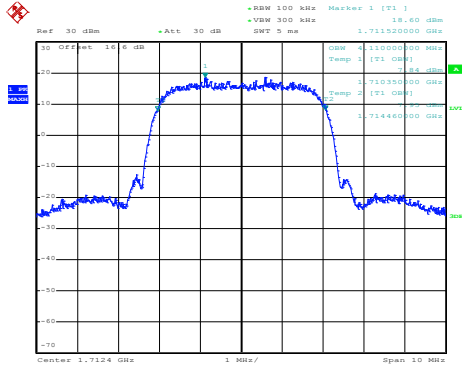

Date: 14.SEP.2017 13:50:56

Middle Channel

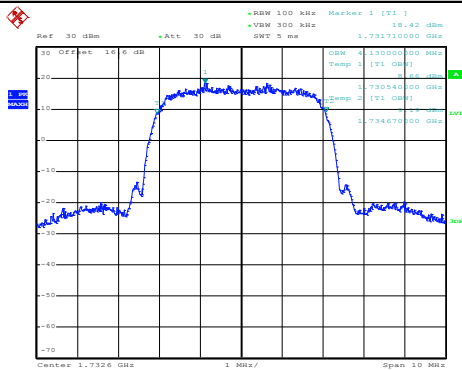

Date: 14.SEP.2017 13:51:24

Highest Channel

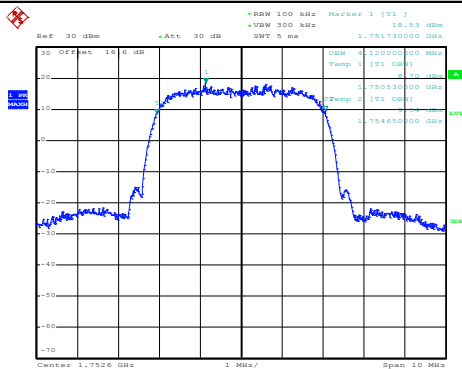

Date: 14.SEP.2017 13:51:51



Conducted Band Edge



WCDMA Band V (RMC 12.2Kbps)

Lowest Band Edge

Highest Band Edge

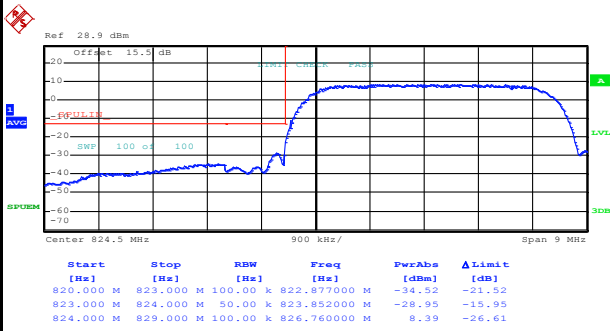

Date: 14.SEP.2017 14:07:52

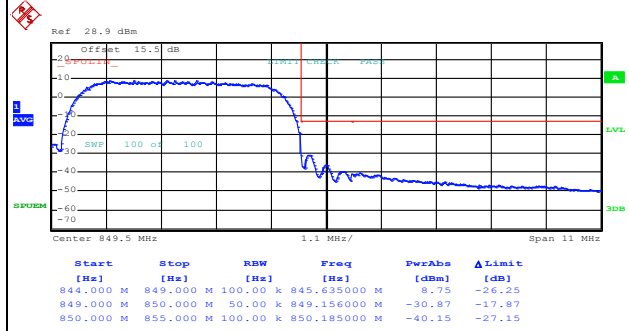

Date: 14.SEP.2017 14:10:34



WCDMA Band II (RMC 12.2Kbps)

Lowest Band Edge

Highest Band Edge

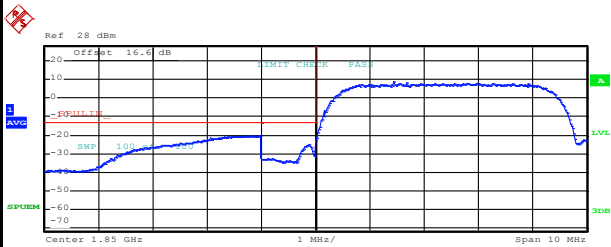

Start [Hz]	Stop [Hz]	RBW [Hz]	Freq [Hz]	PwrAbs [dBm]	ΔLimit [dB]
1.845 G	1.849 G	1.00 M	1.848812 G	-20.01	-7.01
1.849 G	1.850 G	50.00 k	1.849868 G	-25.18	-12.18
1.850 G	1.855 G	100.00 k	1.851440 G	9.03	-25.97

Date: 14.SEP.2017 13:41:27

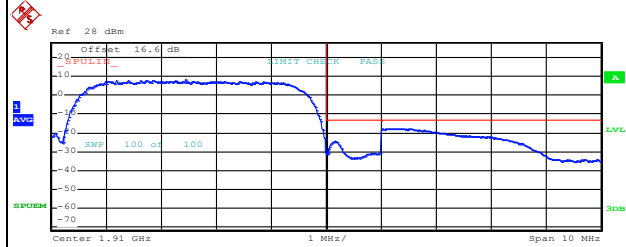

Start [Hz]	Stop [Hz]	RBW [Hz]	Freq [Hz]	PwrAbs [dBm]	ΔLimit [dB]
1.905 G	1.910 G	100.00 k	1.907445 G	8.29	-26.71
1.910 G	1.911 G	50.00 k	1.910160 G	-24.60	-11.60
1.911 G	1.915 G	1.00 M	1.911252 G	-17.66	-4.66

Date: 14.SEP.2017 13:44:10



WCDMA Band IV (RMC 12.2Kbps)

Lowest Band Edge

Highest Band Edge

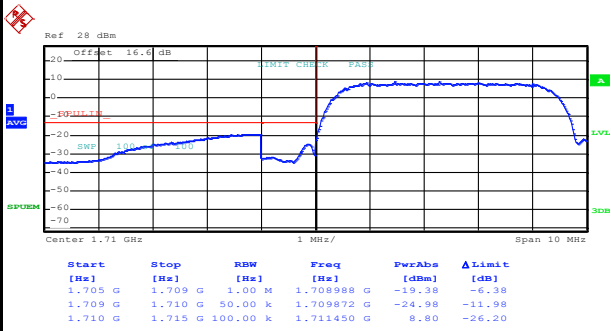

Date: 14.SEP.2017 13:54:36

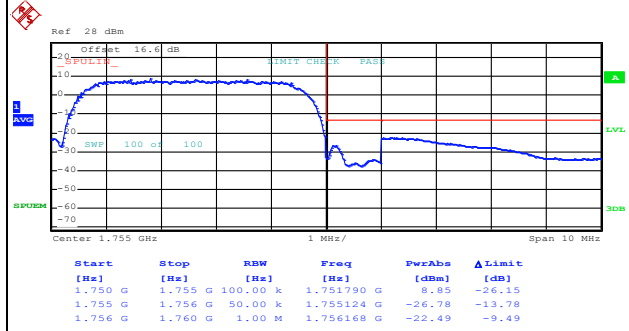

Date: 14.SEP.2017 13:57:17



Conducted Spurious Emission



WCDMA Band V (RMC 12.2Kbps)

Lowest Channel

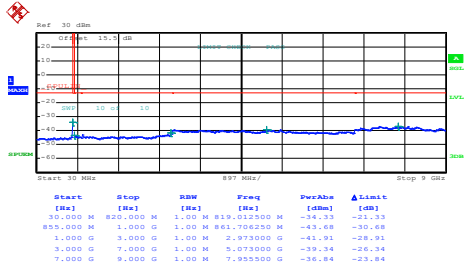

Date: 14.SEP.2017 14:11:28

WCDMA Band II (RMC 12.2Kbps)

Lowest Channel

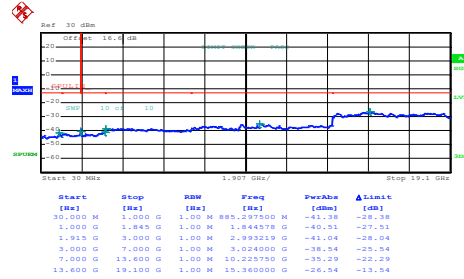

Date: 14.SEP.2017 13:45:21

Middle Channel

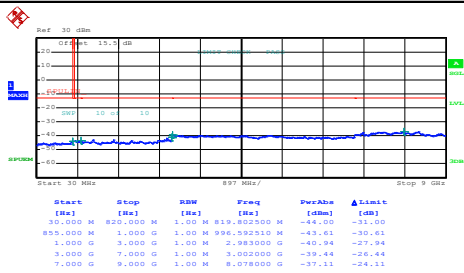

Date: 14.SEP.2017 14:12:13

Middle Channel

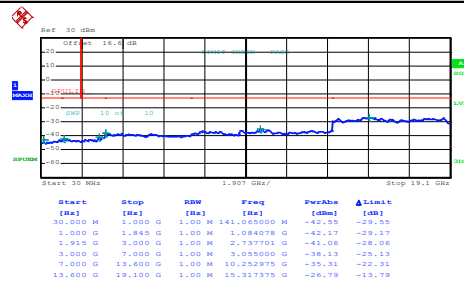

Date: 14.SEP.2017 13:46:06

Highest Channel

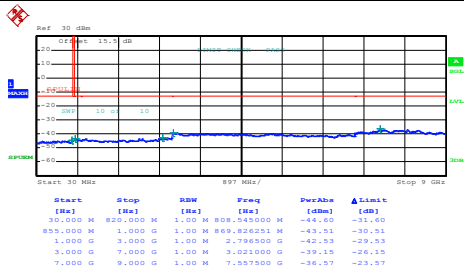

Date: 14.SEP.2017 14:12:59

Highest Channel

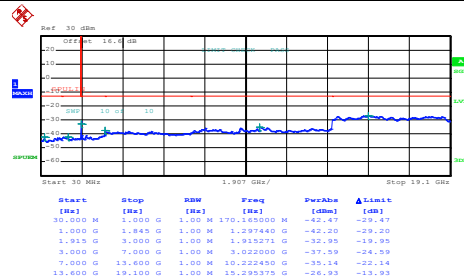

Date: 14.SEP.2017 13:46:52



WCDMA Band IV (RMC 12.2Kbps)

Lowest Channel

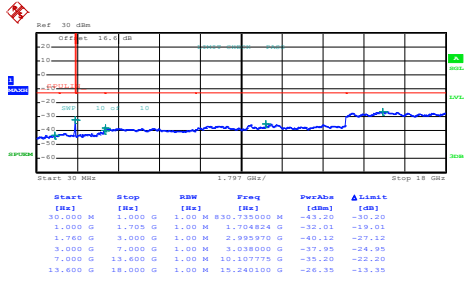

Date: 14.SEP.2017 13:58:15

Middle Channel

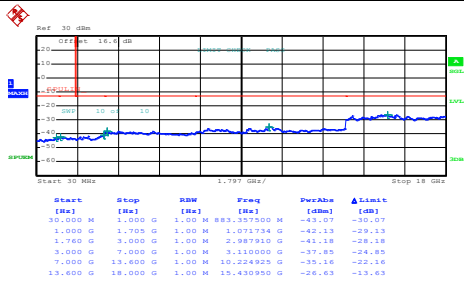

Date: 14.SEP.2017 13:59:01

Highest Channel

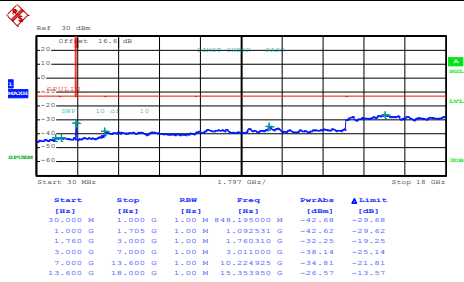

Date: 14.SEP.2017 13:59:46



Frequency Stability

Test Conditions	Middle Channel	WCDMA Band V (RMC 12.2Kbps)	Limit 2.5ppm
Temperature (°C)	Voltage (Volt)	Deviation (ppm)	Result
50	Normal Voltage	0.0203	PASS
40	Normal Voltage	0.0167	
30	Normal Voltage	0.0012	
20(Ref.)	Normal Voltage	0.0000	
10	Normal Voltage	0.0036	
0	Normal Voltage	0.0000	
-10	Normal Voltage	0.0012	
-20	Normal Voltage	0.0000	
-30	Normal Voltage	0.0048	
20	Maximum Voltage	0.0012	
20	Normal Voltage	0.0000	
20	Battery End Point	0.0036	

Test Conditions	Middle Channel	WCDMA Band II (RMC 12.2Kbps)	Limit Note 2.
Temperature (°C)	Voltage (Volt)	Deviation (ppm)	Result
50	Normal Voltage	0.0043	PASS
40	Normal Voltage	0.0016	
30	Normal Voltage	0.0000	
20(Ref.)	Normal Voltage	0.0000	
10	Normal Voltage	0.0005	
0	Normal Voltage	0.0021	
-10	Normal Voltage	0.0011	
-20	Normal Voltage	0.0011	
-30	Normal Voltage	0.0005	
20	Maximum Voltage	0.0032	
20	Normal Voltage	0.0000	
20	Battery End Point	0.0011	



Test Conditions	Middle Channel	WCDMA Band IV (RMC 12.2Kbps)	Limit Note 2.
Temperature (°C)	Voltage (Volt)	Deviation (ppm)	Result
50	Normal Voltage	0.0271	PASS
40	Normal Voltage	0.0202	
30	Normal Voltage	0.0000	
20(Ref.)	Normal Voltage	0.0000	
10	Normal Voltage	0.0029	
0	Normal Voltage	0.0006	
-10	Normal Voltage	0.0012	
-20	Normal Voltage	0.0000	
-30	Normal Voltage	0.0035	
20	Maximum Voltage	0.0012	
20	Normal Voltage	0.0000	
20	Battery End Point	0.0006	

Note:

1. Normal Voltage = 3.85V. ; Battery End Point (BEP) = 3.6 V. ; Maximum Voltage =4.2 V
2. The frequency fundamental emissions stay within the authorized frequency block based on the frequency deviation measured is small.



Appendix B. Test Results of ERP/EIRP and Radiated Test

ERP/EIRP

Channel	Mode	Conducted		ERP	
		Power (dBm)	Power (Watts)	ERP(dBm)	ERP(W)
Lowest	GSM850	32.85	1.9275	28.10	0.6457
Middle	GSM	32.85	1.9275	28.10	0.6457
Highest	(GT - LC = -2.6 dB)	33.00	1.9953	28.25	0.6683
Lowest	GSM850	26.71	0.4688	21.96	0.1570
Middle	EDGE class 8	26.83	0.4819	22.08	0.1614
Highest	(GT - LC = -2.6 dB)	26.91	0.4909	22.16	0.1644
Lowest	WCDMA Band V	22.81	0.1910	18.06	0.0640
Middle	RMC 12.2Kbps	22.77	0.1892	18.02	0.0634
Highest	(GT - LC = -2.6 dB)	22.73	0.1875	17.98	0.0628
Limit	ERP < 7W	Result		PASS	

Channel	Mode	Conducted		EIRP	
		Power (dBm)	Power (Watts)	EIRP(dBm)	EIRP(W)
Lowest	GSM1900	29.52	0.8954	28.32	0.6792
Middle	GPRS class 8	29.59	0.9099	28.39	0.6902
Highest	(GT - LC = -1.2 dB)	29.97	0.9931	28.77	0.7534
Lowest	GSM1900	25.68	0.3698	24.48	0.2805
Middle	EDGE class 8	25.60	0.3631	24.40	0.2754
Highest	(GT - LC = -1.2 dB)	25.79	0.3793	24.59	0.2877
Lowest	WCDMA Band II	21.35	0.1365	20.15	0.1035
Middle	RMC 12.2Kbps	21.27	0.1340	20.07	0.1016
Highest	(GT - LC = -1.2 dB)	21.29	0.1346	20.09	0.1021
Limit	EIRP < 2W	Result		PASS	

Channel	Mode	Conducted		EIRP	
		Power (dBm)	Power (Watts)	EIRP(dBm)	EIRP(W)
Lowest	WCDMA Band IV	21.34	0.1361	17.74	0.0594
Middle	RMC 12.2Kbps	21.46	0.1400	17.86	0.0611
Highest	(GT - LC = -3.6 dB)	21.29	0.1346	17.69	0.0587
Limit	EIRP < 1W	Result		PASS	



Radiated Spurious Emission

<For Up Antenna>

Part22H GSM 850

Mode 1_GSM 850									
Channel	Frequency (MHz)	ERP (dBm)	Limit (dBm)	Over Limit (dB)	SPA Reading (dBm)	S.G. Power (dBm)	TX Cable loss (dB)	TX Antenna Gain (dBi)	Polarization (H/V)
Highest	1696	-43.65	-13	-30.65	-30.57	-45.25	1.00	4.75	H
	2544	-55.12	-13	-42.12	-45.88	-57.10	1.30	5.44	H
	3392	-62.98	-13	-49.98	-56.13	-66.78	1.57	7.52	H
	4240	-62.30	-13	-49.30	-57.43	-66.90	1.90	8.65	H
									H
									H
									H
	1696	-46.35	-13	-33.35	-33.34	-47.95	1.00	4.75	V
	2544	-52.66	-13	-39.66	-43.45	-54.64	1.30	5.44	V
	3392	-61.63	-13	-48.63	-54.52	-65.43	1.57	7.52	V
	4240	-63.45	-13	-50.45	-58.35	-68.05	1.90	8.65	V
									V
									V
									V

Remark: Spurious emissions within 30-1000MHz were found more than 20dB below limit line.



Part22H EDGE 850

Mode 2_EDGE 850									
Channel	Frequency (MHz)	ERP (dBm)	Limit (dBm)	Over Limit (dB)	SPA Reading (dBm)	S.G. Power (dBm)	TX Cable loss (dB)	TX Antenna Gain (dBi)	Polarization (H/V)
Highest	1696	-57.91	-13	-44.91	-44.83	-59.51	1.00	4.75	H
	2544	-65.73	-13	-52.73	-56.49	-67.71	1.30	5.44	H
	3397	-68.43	-13	-55.43	-61.58	-72.25	1.57	7.55	H
									H
									H
									H
									H
	1696	-58.05	-13	-45.05	-45.04	-59.65	1.00	4.75	V
	2544	-67.27	-13	-54.27	-58.06	-69.25	1.30	5.44	V
	3397	-68.32	-13	-55.32	-61.21	-72.14	1.57	7.55	V
									V
									V
									V
									V

Remark: Spurious emissions within 30-1000MHz were found more than 20dB below limit line.



Part22H WCDMA 850

Mode 3_WCDMA 850									
Channel	Frequency (MHz)	ERP (dBm)	Limit (dBm)	Over Limit (dB)	SPA Reading (dBm)	S.G. Power (dBm)	TX Cable loss (dB)	TX Antenna Gain (dBi)	Polarization (H/V)
Lowest	1656	-69.58	-13	-56.58	-56.34	-71.31	0.98	4.86	H
	2480	-69.56	-13	-56.56	-60.07	-71.47	1.28	5.34	H
	3304	-68.64	-13	-55.64	-61.62	-72.08	1.54	7.14	H
									H
									H
									H
									H
	1656	-70.79	-13	-57.79	-57.69	-72.52	0.98	4.86	V
	2480	-69.76	-13	-56.76	-60.29	-71.67	1.28	5.34	V
	3304	-68.64	-13	-55.64	-61.39	-72.08	1.54	7.14	V
									V
									V
									V
									V

Remark: Spurious emissions within 30-1000MHz were found more than 20dB below limit line.



<For Down Antenna>

Part22H GSM 850

Mode 1_GSM 850									
Channel	Frequency (MHz)	ERP (dBm)	Limit (dBm)	Over Limit (dB)	SPA Reading (dBm)	S.G. Power (dBm)	TX Cable loss (dB)	TX Antenna Gain (dBi)	Polarization (H/V)
Highest	1696	-26.29	-13	-13.29	-13.21	-27.89	1.00	4.75	H
	2544	-37.19	-13	-24.19	-27.95	-39.17	1.30	5.44	H
	3392	-32.00	-13	-19.00	-25.15	-35.80	1.57	7.52	H
	4240	-43.20	-13	-30.20	-38.33	-47.80	1.90	8.65	H
	5096	-46.53	-13	-33.53	-45.88	-51.69	2.39	9.70	H
	5944	-40.28	-13	-27.28	-51.75	-45.13	2.88	9.88	H
	6792	-50.79	-13	-37.79	-54.93	-56.53	2.66	10.55	H
	7640	-50.26	-13	-37.26	-56.78	-57.61	2.38	11.88	H
	8488	-57.73	-13	-44.73	-66.42	-65.70	2.37	12.49	H
	1696	-19.50	-13	-6.50	-6.49	-21.10	1.00	4.75	V
	2544	-31.00	-13	-18.00	-21.79	-32.98	1.30	5.44	V
	3392	-31.76	-13	-18.76	-24.65	-35.56	1.57	7.52	V
	4240	-47.69	-13	-34.69	-42.59	-52.29	1.90	8.65	V
	5096	-49.55	-13	-36.55	-48.71	-54.71	2.39	9.70	V
	5944	-43.59	-13	-30.59	-44.95	-48.44	2.88	9.88	V
	6792	-48.90	-13	-35.90	-53.28	-54.64	2.66	10.55	V
	7640	-51.87	-13	-38.87	-58.62	-59.22	2.38	11.88	V
	8488	-55.23	-13	-42.23	-63.68	-63.20	2.37	12.49	V

Remark: Spurious emissions within 30-1000MHz were found more than 20dB below limit line.



Part22H EDGE 850

Mode 2_EDGE 850									
Channel	Frequency (MHz)	ERP (dBm)	Limit (dBm)	Over Limit (dB)	SPA Reading (dBm)	S.G. Power (dBm)	TX Cable loss (dB)	TX Antenna Gain (dBi)	Polarization (H/V)
Highest	1696	-30.94	-13	-17.94	-17.86	-32.54	1.00	4.75	H
	2544	-40.35	-13	-27.35	-31.11	-42.33	1.30	5.44	H
	3392	-38.52	-13	-25.52	-31.67	-42.32	1.57	7.52	H
	4240	-50.24	-13	-37.24	-45.37	-54.84	1.90	8.65	H
	5096	-49.12	-13	-36.12	-48.47	-54.28	2.39	9.70	H
	5944	-48.05	-13	-35.05	-49.52	-52.90	2.88	9.88	H
	6792	-52.22	-13	-39.22	-56.36	-57.96	2.66	10.55	H
	7640	-53.00	-13	-40.00	-59.52	-60.35	2.38	11.88	H
	1696	-22.86	-13	-9.86	-9.85	-24.46	1.00	4.75	V
	2544	-34.44	-13	-21.44	-25.23	-36.42	1.30	5.44	V
	3392	-39.80	-13	-26.80	-32.69	-43.60	1.57	7.52	V
	4240	-50.13	-13	-37.13	-45.03	-54.73	1.90	8.65	V
	5096	-52.61	-13	-39.61	-51.77	-57.77	2.39	9.70	V
	5944	-51.09	-13	-38.09	-52.45	-55.94	2.88	9.88	V
	6792	-52.82	-13	-39.82	-57.2	-58.56	2.66	10.55	V
	7640	-56.71	-13	-43.71	-63.46	-64.06	2.38	11.88	V

Remark: Spurious emissions within 30-1000MHz were found more than 20dB below limit line.



Part22H WCDMA 850

Mode 3_WCDMA 850									
Channel	Frequency (MHz)	ERP (dBm)	Limit (dBm)	Over Limit (dB)	SPA Reading (dBm)	S.G. Power (dBm)	TX Cable loss (dB)	TX Antenna Gain (dBi)	Polarization (H/V)
Lowest	1656	-42.06	-13	-29.06	-28.82	-43.79	0.98	4.86	H
	2472	-45.88	-13	-32.88	-36.39	-47.76	1.28	5.32	H
	3304	-53.69	-13	-40.69	-46.67	-57.13	1.54	7.14	H
	4128	-59.38	-13	-46.38	-54.01	-64.02	1.83	8.63	H
	4952	-62.49	-13	-49.49	-61.27	-67.63	2.31	9.60	H
	5784	-59.94	-13	-46.94	-61.01	-64.82	2.79	9.81	H
									H
	1656	-36.17	-13	-23.17	-23.07	-37.90	0.98	4.86	V
	2472	-41.22	-13	-28.22	-31.75	-43.10	1.28	5.32	V
	3304	-52.86	-13	-39.86	-45.61	-56.30	1.54	7.14	V
	4128	-62.70	-13	-49.70	-57.14	-67.34	1.83	8.63	V
	4952	-63.08	-13	-50.08	-61.63	-68.22	2.31	9.60	V
	5784	-60.83	-13	-47.83	-61.82	-65.71	2.79	9.81	V
									V

Remark: Spurious emissions within 30-1000MHz were found more than 20dB below limit line.



Part24E GPRS 1900

Mode 1_GPRS 1900									
Channel	Frequency (MHz)	EIRP (dBm)	Limit (dBm)	Over Limit (dB)	SPA Reading (dBm)	S.G. Power (dBm)	TX Cable loss (dB)	TX Antenna Gain (dBi)	Polarization (H/V)
Highest	3819	-28.65	-13	-15.65	-22.47	-35.33	1.70	8.38	H
	5730	-34.70	-13	-21.70	-35.65	-41.73	2.76	9.79	H
	7641	-50.03	-13	-37.03	-56.55	-59.53	2.38	11.88	H
	9552	-52.19	-13	-39.19	-63.65	-62.06	2.60	12.47	H
									H
									H
									H
	3819	-29.67	-13	-16.67	-23.29	-36.35	1.70	8.38	V
	5730	-37.44	-13	-24.44	-38.32	-44.47	2.76	9.79	V
	7641	-43.61	-13	-30.61	-50.36	-53.11	2.38	11.88	V
	9552	-50.45	-13	-37.45	-60.1	-60.32	2.60	12.47	V
									V
									V
									V

Remark: Spurious emissions within 30-1000MHz were found more than 20dB below limit line.



Part24E EDGE 1900

Mode 2_EDGE 1900									
Channel	Frequency (MHz)	EIRP (dBm)	Limit (dBm)	Over Limit (dB)	SPA Reading (dBm)	S.G. Power (dBm)	TX Cable loss (dB)	TX Antenna Gain (dBi)	Polarization (H/V)
Highest	3819	-34.87	-13	-21.87	-28.69	-41.55	1.70	8.38	H
	5730	-42.31	-13	-29.31	-43.26	-49.34	2.76	9.79	H
	7641	-54.38	-13	-41.38	-60.9	-63.88	2.38	11.88	H
	9552	-55.60	-13	-42.60	-67.06	-65.47	2.60	12.47	H
									H
									H
									H
	3819	-36.23	-13	-23.23	-29.85	-42.91	1.70	8.38	V
	5730	-43.01	-13	-30.01	-43.89	-50.04	2.76	9.79	V
	7641	-50.52	-13	-37.52	-57.27	-60.02	2.38	11.88	V
	9552	-53.38	-13	-40.38	-63.03	-63.25	2.60	12.47	V
									V
									V
									V

Remark: Spurious emissions within 30-1000MHz were found more than 20dB below limit line.



Part24E WCDMA 1900

Mode 3_WCDMA 1900									
Channel	Frequency (MHz)	EIRP (dBm)	Limit (dBm)	Over Limit (dB)	SPA Reading (dBm)	S.G. Power (dBm)	TX Cable loss (dB)	TX Antenna Gain (dBi)	Polarization (H/V)
Lowest	3700	-45.90	-13	-32.90	-39.56	-52.47	1.67	8.24	H
	5562	-56.63	-13	-43.63	-57.18	-63.69	2.66	9.72	H
	7410	-59.61	-13	-46.61	-65.59	-68.77	2.46	11.62	H
									H
									H
									H
									H
	3700	-44.58	-13	-31.58	-37.99	-51.15	1.67	8.24	V
	5562	-52.95	-13	-39.95	-53.46	-60.01	2.66	9.72	V
	7410	-58.84	-13	-45.84	-65.12	-68.00	2.46	11.62	V
									V
									V
									V
									V

Remark: Spurious emissions within 30-1000MHz were found more than 20dB below limit line.



Part27L WCDMA 1700

Mode 1_WCDMA 1700									
Channel	Frequency (MHz)	EIRP (dBm)	Limit (dBm)	Over Limit (dB)	SPA Reading (dBm)	S.G. Power (dBm)	TX Cable loss (dB)	TX Antenna Gain (dBi)	Polarization (H/V)
Middle	3469	-56.23	-13	-43.23	-49.52	-62.50	1.59	7.86	H
	5198	-58.88	-13	-45.88	-58.5	-66.13	2.45	9.70	H
	6927	-60.44	-13	-47.44	-65.1	-68.54	2.61	10.71	H
									H
									H
									H
									H
	3469	-56.99	-13	-43.99	-49.99	-63.26	1.59	7.86	V
	5198	-62.13	-13	-49.13	-61.6	-69.38	2.45	9.70	V
	6927	-59.83	-13	-46.83	-64.77	-67.93	2.61	10.71	V
									V
									V
									V
									V

Remark: Spurious emissions within 30-1000MHz were found more than 20dB below limit line.